

TECHNICAL SERVICE MANUAL

— **Feng Xia Series**

GREE ELECTRIC APPLIANCES, INC. OF ZHUHAI

Jinji West Rd. Qianshan Zhuhai

Guangdong China

Introduction

In this technical service manual, you will find rich references to Feng Xia Series products, including photos, technical specifications, explosive views, spare parts lists and circuit diagrams. Service people and engineers of Gree's customers and distributors would find it a very handy source of technical information of our products.

Technical Support Department
GREE ELECTRIC APPLIANCES, INC. OF ZHUHAI
Nov. 2002

Editor In Chief: Chen Jianmin

Compiler: Chen Zhian Ouyang Jun Tian Guoku
Jia Tianwei Wang Min Yang Rong Cao Xuan

Proofreader: Li Huan Wang Wenbin He Wengen Wang Xin Yao Yongfeng
Xiao Kai

Designer of Cover: Li Jiasheng Sheng Zhiguo

CONTENTS

1.Feng Xia series	1
1.1 Summary	1
1.2 Technical specifications	3
1.3 Performance curves	9
1.4 Outlines and dimensions of indoor unit	12
1.5 Outlines and dimensions of outdoor unit	13
1.6 Explosive view and spare parts list of indoor unit	14
1.7 Explosive view and spare parts list of outdoor unit	18
1.8 Circuit diagram	22
1.9 PCB function manual	31
2.Feng Xia Inverter Type	37
2.1 Summary	37
2.2 Technical specification	39
2.3 Performance curves	40
2.4 Outlines and dimensions of indoor unit	43
2.5 Outlines and dimensions of outdoor unit	44
2.6 Explosive view and spare parts list of indoor unit	46
2.7 Explosive view and spare parts list of outdoor unit	48
2.8 Circuit diagram	50
2.9 PCB function manual	51

1. Feng Xia Series

1.1 Summary



Fig. 1.1

MODEL	NOTE
KF-70GW/A1 KFR-70GW/A1	CE STANDARD 1Ph 220-230V 50Hz R22
KF-70GW/NA1 KFR-70W/NA1	CE STANDARD 1Ph 220-230V 50Hz R407C
GSW30-22L/A GSW30-22R/A	1Ph 220V 60Hz R22
KFR-70GW/A1-12405	1Ph 240V 50Hz R22
KF-80GW/A1 KFR-80GW/A1	1Ph 220-230V 50Hz R22
KF-80GW/NA1 KFR-80GW/NA1	1Ph 220-230V 50Hz R407C

1.2 Technical specifications.

Table 1-1

Model		KF-70GW/A1	KFR-70GW/A1	
Function		Cooling	Cooling	Heating
Power supply		1Ph 220-230V 50Hz		
Capacity(W)		7000	7000	7500
Rated input(W)		2750	2750	2650
Rated current(A)		13	13	12.8
Air flow(m ³ /h)		1080		
Dehumidifying volume(L/h)		2.8		
EER/C.O.P(W/W)		2.55	2.55	2.83
Indoor unit	Model	KF-70G/A1	KFR-70G/A1	
	Motor fan speed(r/min)	1420		
	Output power(W)	28		
	Fan type/piece	Cross flow fan-1		
	Diameter-length(mm)	φ 108 × 954		
	Evaporator	Aluminum fin-copper tube		
	Row-fin distance(mm)	3-1.5		
	Working area(m ²)	0.28		
	Swing motor	MP35EA		
	Input power(W)	4		
	Fuse(A)	Controllor 3.15A Transformer 0.2A		
	Working capacitor(μF)	3.5		
	Noise(dB(A))	≤ 51		
	Dimension(width-height-depth)mm	1220 × 360 × 206		
Net weight(kg)	27			
Outdoor unit	Model	KF-70W/A1	KFR-70W/A1	
	Input power(W)	2720	2720/2620	
	Current(A)	13.0	13.0/12.6	
	L.R.A.(A)	65		
	Throttling method	Capillary		
	Compressor	AWG5532EXC or AWG5532EVA		
	Power(W)	2680		
	Protector	External overload protection		
	Starting method	By capacitor		
	Working temp.	Exhaust temperature ≤ 115℃		
	Condenser	Aluminum-copper		
	Pipe-diameter	φ 9.52		
	Working area(m ²)	0.6		
	Fan motor speed(rpm)	780		
	Type-piece	Axial fan-1		
	Diameter(mm)	φ 455		
	Defrosting method	Auto defrost		
	Noise dB(A)	58		
	Dimension(mm)(width-height-depth)	950 × 840 × 412		
Net weight(kg)	75			
Refrigerant charge (kg)	R22 2.5			
Connecting pipe	Outer diameter	Liquid pipe	φ 9.52 (3/8")	
		Gas pipe	φ 16(5/8")	
	Max distance	Height(m)	5	
		Length(m)	10	

The technical data are subject to change without notice .Please refer to the nameplate of the unit.

Feng Xia Series

Table 1-2

Model		KF-70GW/NA1	KFR-70GW/NA1	
Function		Cooling	Cooling	Heating
Power supply		1Ph 220V-230V 50Hz		
Capacity(W)		7000	7000	7500
Rated input(W)		3250	3250	3200
Rated current(A)		15.4	15.4	15.2
Air flow(m ³ /h)		1080		
Dehumidifying volume(L/h)		2.8		
EER/C.O.P(W/W)		2.35	2.35	2.58
Indoor unit	Model	KF-70G/NA1	KFR-70G/NA1	
	Motor fan speed(r/min)	1420		
	Output power(w)	28		
	Fan type/piece	Cross flow fan-1		
	Diameter-length(mm)	φ 108 × 955		
	Evaporator	Aluminum fin-copper tube		
	Row-fin distance(mm)	3-1.5		
	Working area(m ²)	0.28		
	Swing motor	MP35EA		
	Input power(W)	4		
	Fuse(A)	Controllor 3.15A Transformer 0.2A		
	Working capacitor(μF)	3.5		
	Noise(dB(A))	≤ 51		
	Dimension(width-height-depth)mm	1220 × 360 × 206		
Net weight(kg)	27			
Outdoor unit	Model	KF-70W/NA1	KFR-70W/NA1	
	Input power(W)	3220	3220/3170	
	Current(A)	15.2	15.2/15.0	
	L.R.A.(A)	75		
	Throttling method	Capillary		
	Compressor	C-RN220H5B		
	Power(W)	2950		
	Protector	External overload protection		
	Starting method	By capacitor		
	Working temp.	Exhaust temperature ≤ 115℃		
	Condenser	Aluminum-copper		
	Pipe-diameter	φ 9.52		
	Working area(m ²)	0.6		
	Fan motor speed(rpm)	780		
	Type-piece	Axial fan-1		
	Diameter(mm)	φ 455		
	Defrosting method	Auto defrost		
	Noise dB(A)	59		
	Dimension(mm)(width-height-depth)	950 × 840 × 412		
	Net weight(kg)	75		
Refrigerant charge (kg)	R407C 2.5			
Connecting pipe	Outer diameter	Liquid pipe	φ 9.52 (3/8")	
		Gas pipe	φ 16(5/8")	
	Max distance	Height(m)	5	
		Length(m)	10	

The technical data are subject to change without notice .Please refer to the nameplate of the unit.

Feng Xia Series

Table 1-3

Model		GSW30-22L/A	GSW30-22R/A	
Function		Cooling	Cooling	Heating
Power supply		1Ph 220V 60Hz		
Capacity(W)		7000	7000	7500
Rated input(W)		3200	3200	3100
Rated current(A)		14.5	14.5	14.1
Air flow(m ³ /h)		1080		
Dehumidifying volume(L/h)		2.8		
EER/C.O.P(W/W)		2.2	2.2	2.4
Indoor unit	Model	GSW30-22L/A(I)	GSW30-22R/A(I)	
	Motor fan speed(r/min)	1420		
	Output power(W)	28		
	Fan type/piece	Cross flow fan-1		
	Diameter-length(mm)	φ 108 × 954		
	Evaporator	Aluminum fin-copper tube		
	Row-fin distance(mm)	3-1.5		
	Working area(m ²)	0.28		
	Swing motor	MP35EA		
	Input power(W)	4		
	Fuse(A)	Controller3.15A Transformer0.2A		
	Working capacitor(μF)	3.5		
	Noise(dB(A))	≤ 51		
	Dimension(width-height-depth)(mm)	1220 × 360 × 206		
Net weight(kg)	27			
Outdoor unit	Model	GSW30-22L/A(O)	GSW30-22R/A(O)	
	Input power(W)	3170	3170/3070	
	Current(A)	14.0	14.0/13.8	
	L.R.A.(A)	69		
	Throttling method	Capillary		
	Compressor	CRFQ-0250-PFV-501		
	Power(W)	2680		
	Protector	External overload protection		
	Starting method	By capacitor		
	Working temp.	Exhaust temperature ≤ 115℃		
	Condenser	Aluminum-copper		
	Pipe-diameter	φ 9.52		
	Working area(m ²)	0.6		
	Fan motor speed(rpm)	780		
	Type-piece	Axial fan-1		
	Diameter(mm)	φ 455		
	Defrosting method	Auto defrost		
	Noise dB(A)	58		
	Dimension(mm)(width-height-depth)	950 × 840 × 412		
Net weight(kg)	75			
Refrigerant charge (kg)	R22 2.5			
Connecting pipe	Outer diameter	Liquid pipe(mm)	φ 9.52(3/8")	
		Gas pipe(mm)	φ 16(5/8")	
	Max distance	Height(m)	5	
		Length(m)	10	

The technical data are subject to change without notice .Please refer to the nameplate of the unit.

Feng Xia Series

Table 1-4

Model		KFR-70GW/A1-12405	
Function		Cooling	Heating
Power supply		1Ph 240V 50Hz	
Capacity (W)		7000	7500
Rated input (W)		3050	2980
Rated current (A)		13.2	13
Air flow (M ³ /h)		960	
Dehumidifying volume (L/h)		1.2	
EER/C.O.P(W/W)		2.41	2.45
Indoor unit	Model		KFR-70G/A1-12405
	Motor fan speed(r/min)		1420/1300/1100
	Output power(W)		60
	Fan type/piece		Cross flow fan-1
	Diameter-length(mm)		φ 108 × 955
	Evaporator		Aluminum fin-copper tube
	Row-fin distance(mm)		1.5
	Working area(m ²)		0.13
	Swing motor		MP35EA
	Input power(W)		2
	Fuse(A)		Controllor 3.15A Transformer 0.2A
	Working capacitor(μF)		1
	Noise(dB(A))		≤ 50
	Dimension(width-height-depth)mm		1220 × 360 × 205
Net weight(kg)		24	
Outdoor unit	Model		KFR-70W/A1-12405
	Input power (W)		2550
	Current (A)		12
	L.R.A. (A)		68
	Throttling method		Capillary
	Compressor		AWG5532EVA or AWG5532EXC
	Power (W)		2600
	Protector		Internal overload protection
	Starting method		Power supply module
	Working temp.		Exhaust temperature ≤ 130℃
	Condenser		Aluminum-copper
	Pipe-diameter		φ 9.52/ φ 16
	Working area(m ²)		0.3
	Fan motor speed(rpm)		780
	Type-piece		Axial fan-1
	Diameter(mm)		φ 455
	Defrosting method		Auto defrost
	Noise dB(A)		60
Dimension(mm)(width-height-depth)		840 × 950 × 412	
Net weight(kg)		75	
Refrigerant charge (kg)		R22	
Connecting pipe	Length (m)		5
	Outer diameter	Liquid pipe	φ 16
		Gas pipe	φ 9.52
	Max distance	Height(m)	5
Length(m)		10	

The technical data are subject to change without notice .Please refer to the nameplate of the unit.

Feng Xia Series

Table 1-5

Model		KF-80GW/A1	KFR-80GW/A1	
Function		Cooling	Cooling	Heating
Power supply		1Ph 220-230V 50Hz		
Capacity(W)		8000	8000	8500
Rated input(W)		3700	3700	3680
Rated current(A)		6.8	6.8	6.6
Air flow(m ³ /h)		1040		
Dehumidifying volume(L/h)		2.8		
EER/C.O.P(W/W)		2.1	2.1	2.1
Indoor unit	Model	KF-80G/A1	KFR-80G/A1	
	Motor fan speed(r/min)	1420		
	Output power(W)	28		
	Fan type/piece	Cross flow fan-1		
	Diameter-length(mm)	φ 108 × 955		
	Evaporator	Aluminum fin-copper tube		
	Row-fin distance(mm)	3-1.5		
	Working area(m ²)	954 × 303		
	Swing motor	MP35EA		
	Input power(W)	4		
	Fuse(A)	Controller3.15A Transformer0.2A		
	Working capacitor(μF)	3.5		
	Noise(dB(A))	≤ 51		
	Dimension(width-height-depth)(mm)	1220 × 360 × 205		
Net weight(kg)	27			
Outdoor unit	Model	KF-80W/A1	KFR-80W/A1	
	Input power(W)	3220	3220/3170	
	Current(A)	15.2	15.2/15.0	
	L.R.A.(A)	75		
	Throttling method	Capillary		
	Compressor	C-SB263H8A		
	Power(W)	2950		
	Protector	External overload protection		
	Starting method	By capacitor		
	Working temp.	Exhaust temperature ≤ 115℃		
	Condenser	Aluminum-copper		
	Pipe-diameter	φ 9.52		
	Working area(mm×mm)	813 × 683		
	Fan motor speed(rpm)	850		
	Type-piece	Axial fan-1		
	Diameter(mm)	φ 455		
	Defrosting method	Auto defrost		
	Noise dB(A)	60		
	Dimension(mm)(width-height-depth)	950 × 840 × 412		
	Net weight(kg)	75		
Refrigerant charge (kg)	R22 2.4	R22 2.55		
Connecting pipe	Outer diameter	Liquid pipe(mm)	φ 9.52	
		Gas pipe(mm)	φ 16	
	Max distance	Height(m)	5	
		Length(m)	10	

The technical data are subject to change without notice .Please refer to the nameplate of the unit.

Feng Xia Series

Table 1-6

Model		KF-80GW/NA1	KFR-80GW/NA1	
Function		Cooling	Cooling	Heating
Power supply		1Ph 220-230V 50Hz		
Capacity(W)		8000	8000	8500
Rated input(W)		3700	3700	3680
Rated current(A)		6.8	6.8	6.6
Air flow(m ³ /h)		1040		
Dehumidifying volume(L/h)		2.8		
EER/C.O.P(W/W)		2.1	2.1	2.1
Indoor unit	Model	KF-80G/NA1	KFR-80G/NA1	
	Motor fan speed(r/min)	1420		
	Output power(W)	28		
	Fan type/piece	Cross flow fan-1		
	Diameter-length(mm)	φ 108 × 955		
	Evaporator	Aluminum fin-copper tube		
	Row-fin distance(mm)	3-1.5		
	Working area(m ²)	954 × 303		
	Swing motor	MP35EA		
	Input power(W)	4		
	Fuse(A)	Controller3.15A Transformer0.2A		
	Working capacitor(μF)	3.5		
	Noise(dB(A))	≤ 51		
	Dimension(width-height-depth)(mm)	1220 × 360 × 205		
Net weight(kg)	27			
Outdoor unit	Model	KF-80W/NA1	KFR-80W/NA1	
	Input power(W)	3220	3220/3170	
	Current(A)	15.2	15.2/15.0	
	L.R.A.(A)	75		
	Throttling method	Capillary		
	Compressor	C-SBN263H8A		
	Power(W)	2950		
	Protector	External overload protection		
	Starting method	By capacitor		
	Working temp.	Exhaust temperature ≤ 115℃		
	Condenser	Aluminum-copper		
	Pipe-diameter	φ 9.52		
	Working area(mm×mm)	813 × 683		
	Fan motor speed(rpm)	850		
	Type-piece	Axial fan-1		
	Diameter(mm)	φ 455		
	Defrosting method	Auto defrost		
	Noise dB(A)	60		
	Dimension(mm)(width-height-depth)	950 × 840 × 412		
	Net weight(kg)	75		
Refrigerant charge (kg)	R407C 2.4	R407C 2.6		
Connecting pipe	Outer diameter	Liquid pipe(mm)	φ 9.52	
		Gas pipe(mm)	φ 16	
	Max distance	Height(m)	5	
		Length(m)	10	

The technical data are subject to change without notice .Please refer to the nameplate of the unit.

1.3 Performance curves

Cooling operation

Condition: In testing, indoor and outdoor have same work condition

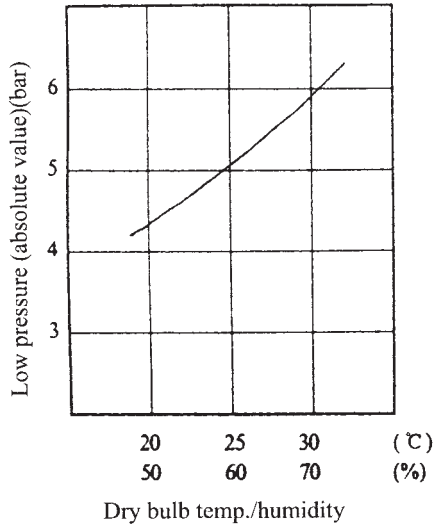

(a)

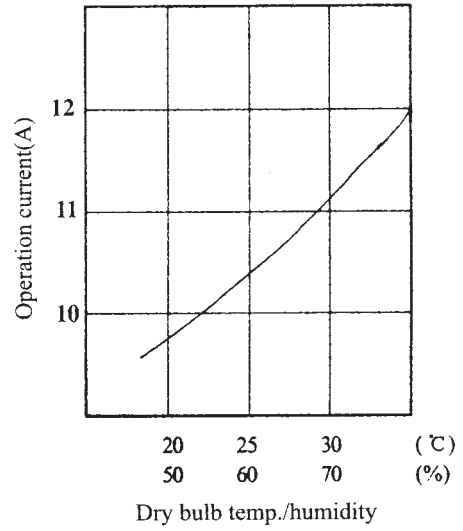

(b)

Heating operation

Indoor work condition: dry bulb temp. 21, wet bulb temp. 15.5

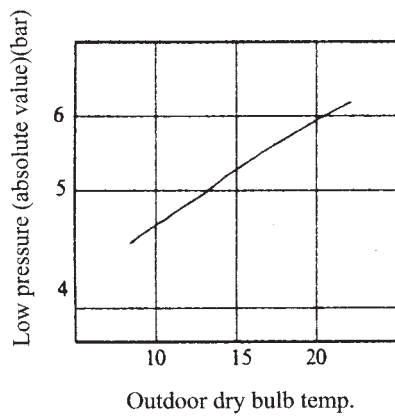

(c)

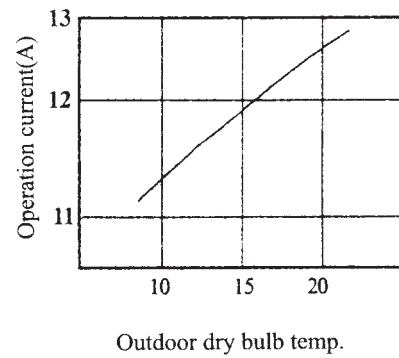

(d)

Fig. 1.2

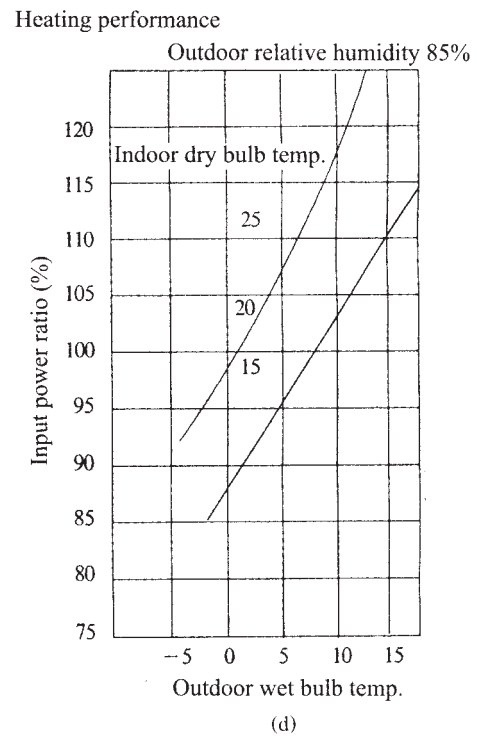
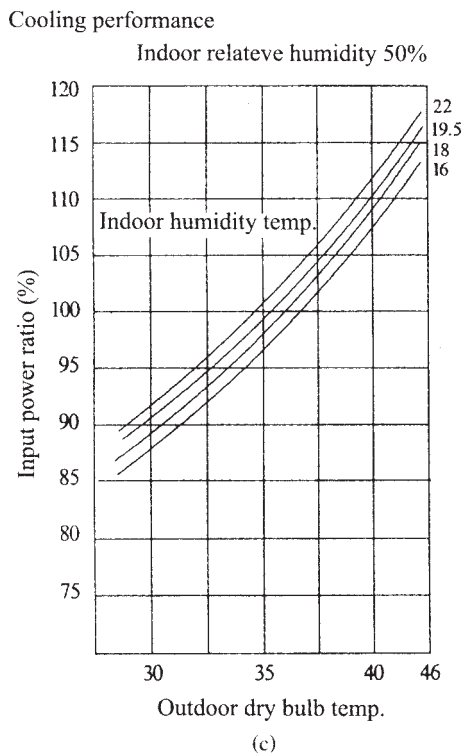
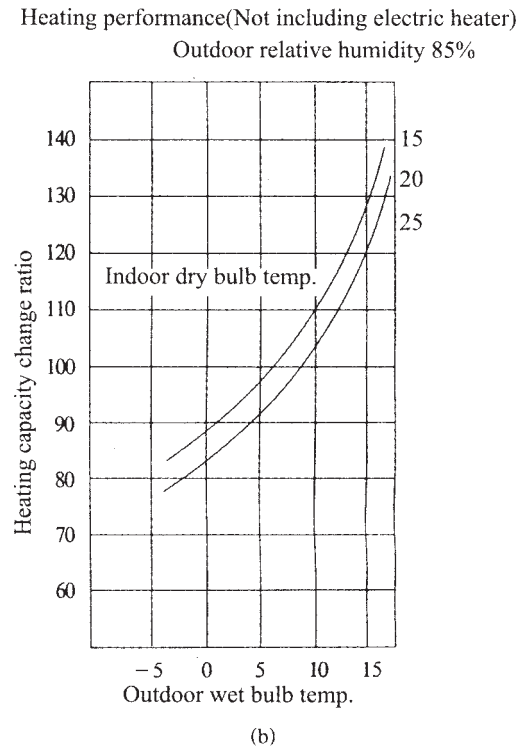
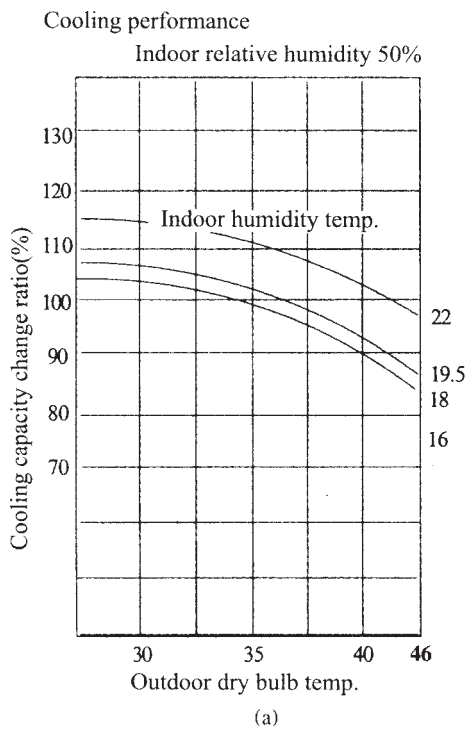
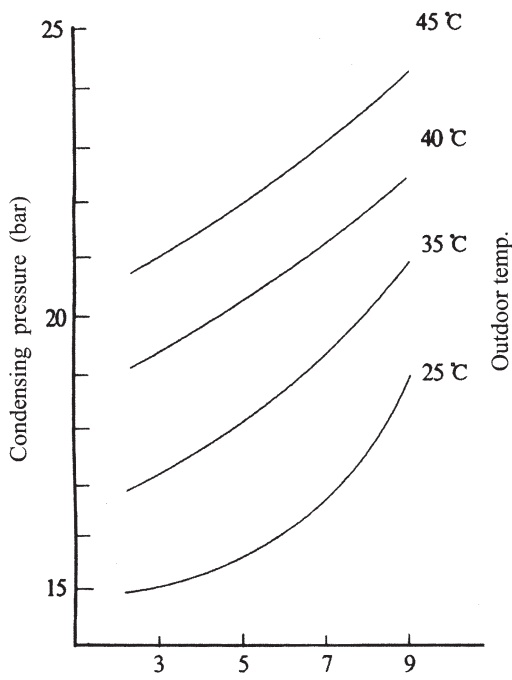
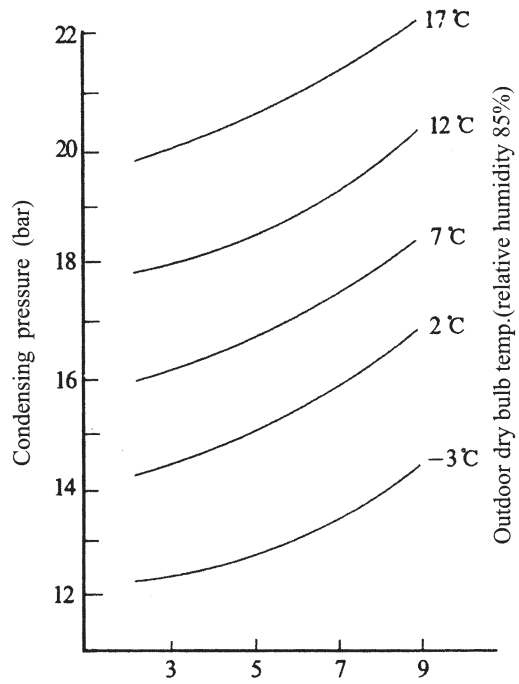

Fig. 1.3



Evaporative pressure(bar)
 The affection to the charging quantity by pressure under cooling work condition.
 Indoor work condition: 27°C dry bulb ,
 19.5°C wet bulb

(e)



Evaporative pressure (bar)
 The affection to the charging quantity by pressure under heating work condition.
 Indoor work condition: 21°C dry bulb temp. 21% relative humidity

(f)

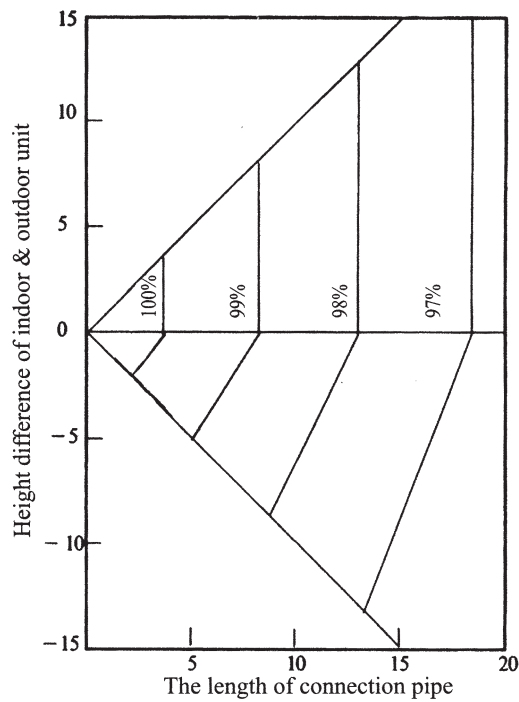

Cooling capacity vary with the length of connection pipe

(g)

Fig. 1.4

1.4 Outlines and dimensions of indoor unit

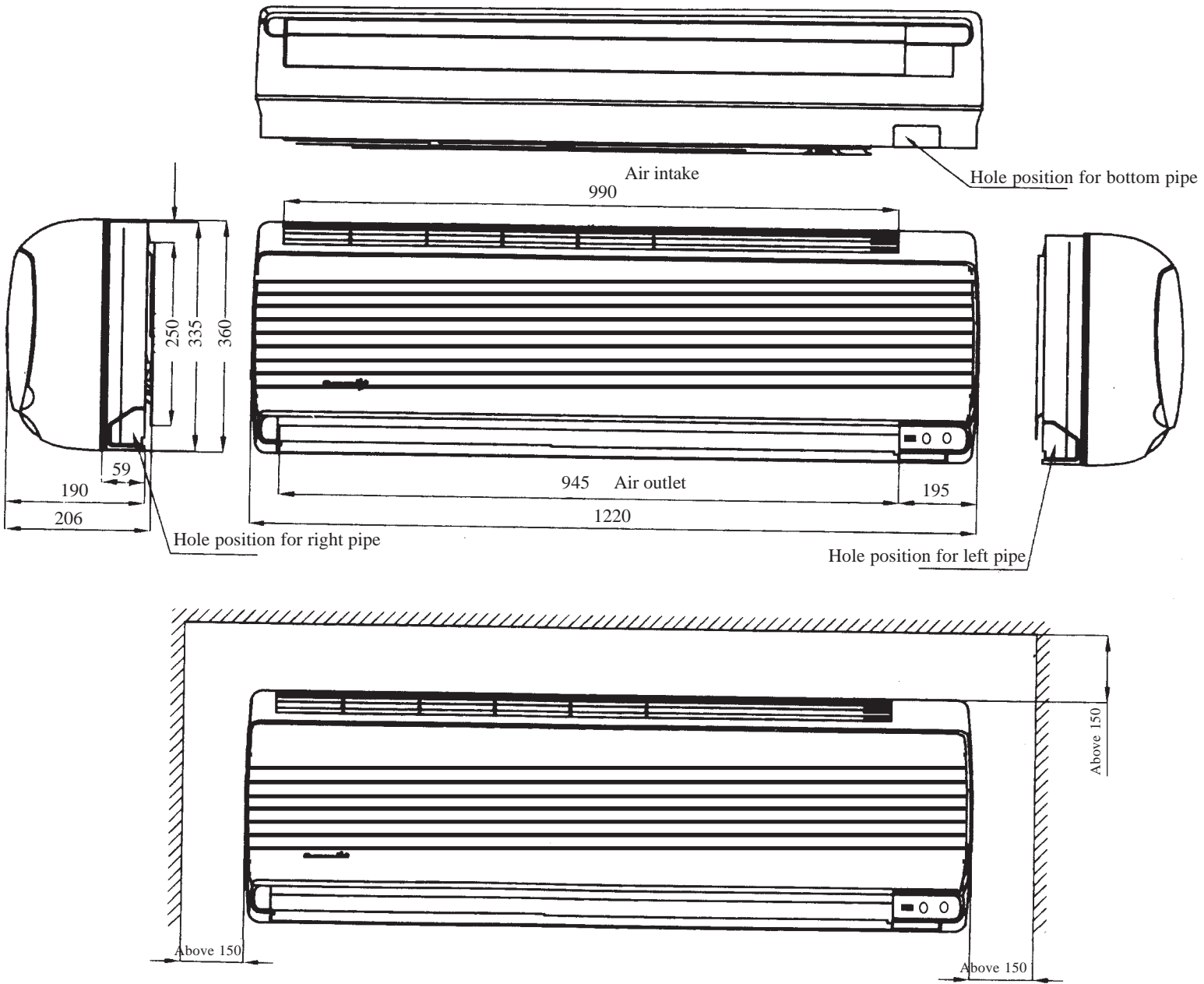
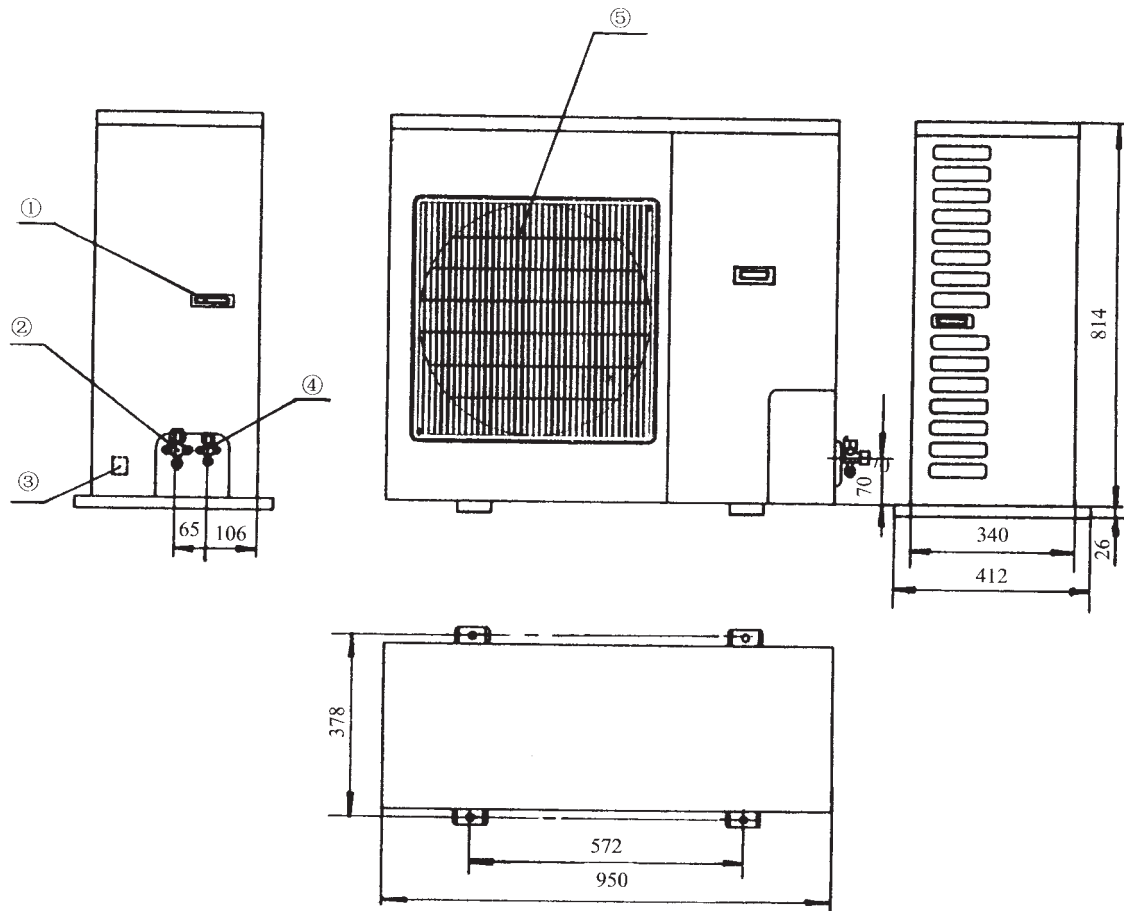

Fig. 1.5

1.5 Outlines and dimensions of outdoor unit



① Handle for moving ② Liquid valve assy. ③ Wire hole ④ Gas valve assy. ⑤ Front panel

Fig. 1.6

1.6 Explosive view and spare parts list of indoor unit

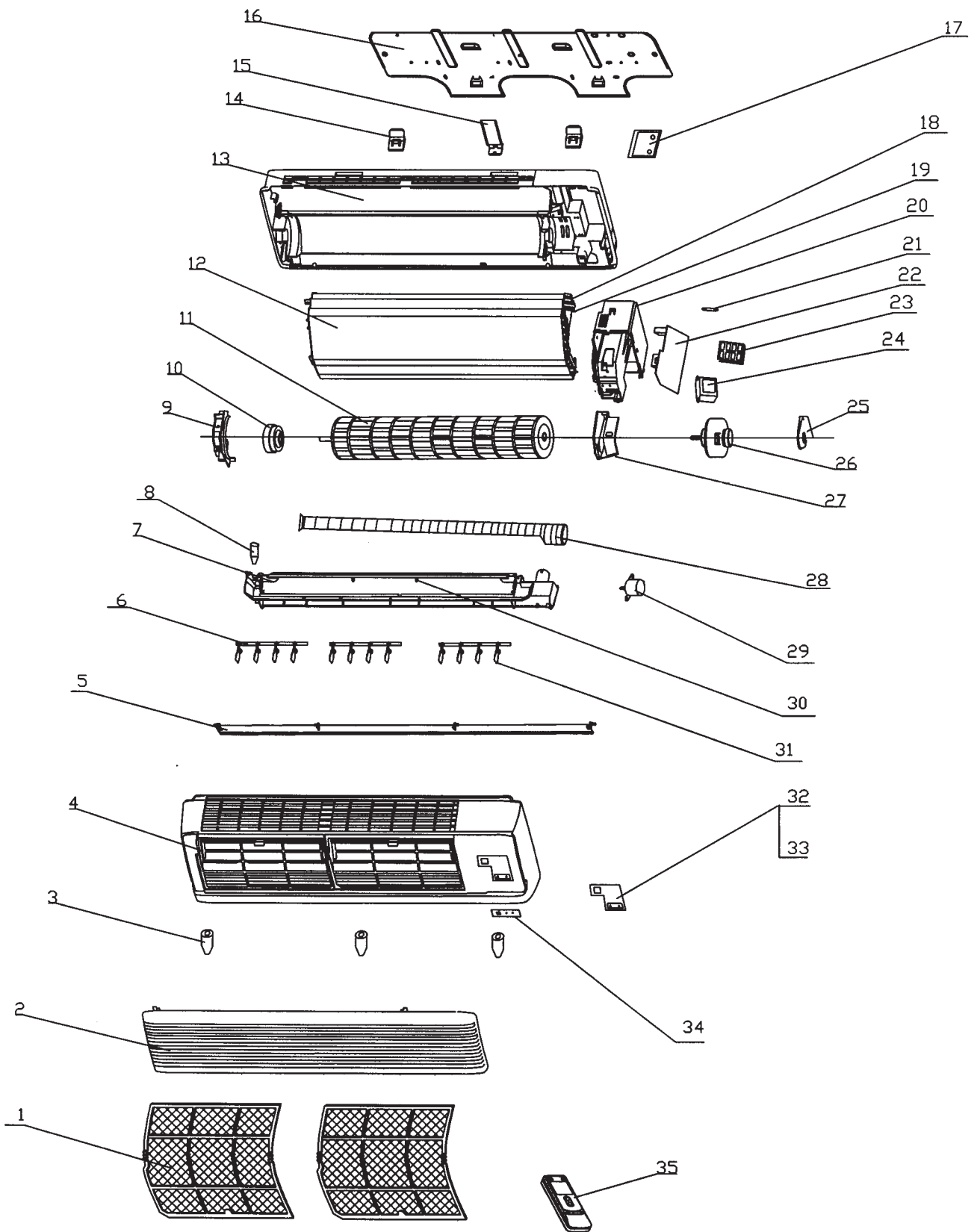

Fig. 1.7

Feng Xia Series

Table 1-7

No	Description		Part No						Qty
			KF-70G/A1	KFR-70G/A1	KF-70G/NA1	KFR-70G/NA1	GSW30-22L/A(I)	GSW30-22R/A(I)	
1	Filter	过滤网	11122005	11122005	11122005	11122005	11122005	11122005	2
2	Front Panel	面板	20002020	20002020	20002020	20002020	20002020	20002020	1
3	Screw cover	螺钉盖	24252002	24252002	24252002	24252002	24252002	24252002	3
4	Front Case	面板体	20002021	20002021	20002021	20002021	20002021	20002021	1
5	Guide Louver	导风板	10512009	10512009	10512009	10512009	10512009	10512009	1
6	Connecting Lever	导风连杆	10582005	10582005	10582005	10582005	10582005	10582005	3
7	Water Tray	接水盘	12412061	12412061	12412061	12412061	12412061	12412061	1
8	Drain Stem	排水口堵头	06812061	06812061	06812061	06812061	06812061	06812061	1
9	Left Evap Supporter	蒸发器左支撑	01072435	01072435	01072435	01072435	01072435	01072435	1
10	Ring of Bearing	贯流风叶轴承胶圈	76512044	76512044	76512044	76512044	76512044	76512044	1
11	Cross Fan Assy	贯流风叶部件	10352397	10352397	10352397	10352397	10352397	10352397	1
12	Evaporator Assy	蒸发器组件	01002018	01002018	\	\	01002018	01002018	1
	Evaporator Assy	蒸发器组件	\	\	010020181	010020181	\	\	1
13	Rear Case	底座	26152440	26152440	26152440	26152440	26152440	26152440	1
14	Fixing Hook	底座固定扣	26152442	26152442	26152442	26152442	26152442	26152442	2
15	Rear Pipe Clamp	压管夹	02142204	02142204	02142204	02142204	02142204	02142204	1
16	Wall Mounting Plate	壁挂板	01252205	01252205	63262017	63262017	63262017	63262017	1
17	Pipe Clamp	管夹	02142440	02142440	02142440	02142440	02142440	02142440	1
18	Sensor Suppor	感温头支架	24211121	24211121	24211121	24211121	24211121	24211121	1
19	Sensor Holder	感温头插片 B	42020063	42020063	42020063	42020063	42020063	42020063	1
20	Electric Box	电器盒	20102006	20102006	20102006	20102006	20102006	20102006	1
21	Wire Clamp	电线夹	71010103	71010103	71010103	71010103	71010103	71010103	1
22	PCB 5F51J	控制器 5F51J	30025581	\	30025581	\	30025581	\	1
	PCB 5F52J	控制器 5F52J	\	30025582	\	30025582	\	30025582	1
23	Terminal board	四位接线板 T4B3A	42011233	42011233	42011233	42011233	42011233	42011233	1
24	Transformer SC21C	电源变压器	43110161	43110161	43110161	43110161	43110161	43110161	1
25	Motor Clamp	电机固定卡	02112001	02112001	02112001	02112001	02112001	02112001	2
26	Motor FN25D	电机 FN25D	15012105	15012105	15012105	15012105	\	\	1
26	Motor FN25C	电机 FN25C	\	\	\	\	15012107	15012107	1
27	Right Evap Supporter	蒸发器右支撑	01072436	01072436	01072436	01072436	01072436	01072436	1
28	Drainage Pipe	排水管	05232411	05232411	05232411	05232411	05232411	05232411	1
29	Motor MP35EA	步进电机 MP35EA	15210104	15210104	15210104	15210104	15210104	15210104	1
30	Tray Supporter	接水盘中支撑	12122245	12122245	12122245	12122245	12122245	12122245	2
31	Swing Louver	导风叶片	10512006	10512006	10512006	10512006	10512006	10512006	12
32	Electric Box Cover	接线盖板	22242201	22242201	22242201	22242201	22242201	22242201	1
33	Switch Mask	显示灯标牌	60310178	60310178	60310178	60310178	60310178	60310178	1
34	Indicating Mask	显示接收板	22432200	22432200	22432200	22432200	22432200	22432200	1
35	Remote Controller	遥控器 Y512	30512506	30512506	30512506	30512506	30512506	30512506	1
36	Power Cord	电源线	40020333	40020333	40020333	40020333	40020237	40020237	1
37	Connecting Cable	电源连接线	40020427	40020427	40020427	40020427	40020455	40020455	1
38	Signal Cable	信号控制线	\	40032103	40032154	40032153	40032144	40032137	1
39	room sensor	室温感温包	39000038	39000038	39000038	39000038	39000038	39000038	1
40	tube sensor	管温感温包	39000118	39000118	39000118	39000118	39000118	39000118	1

The data are subject to change without notice.

Feng Xia Series

Table 1-8

No.	Description		Part No.	Qty
			KFR-70G/A1-12405	
1	Filter	过滤网	11122005	2
2	Front Panel	面板	20002020	1
3	Screw cover	螺钉盖	24252002	3
4	Front Case	面板体	20002021	1
5	Guide Louver	导风板	10512009	1
6	Connecting Lever	导风连杆	10582005	3
7	Water Tray	接水盘	12412061	1
8	Drain Stem	排水口堵头	06812061	1
9	Left Evap Supporter	蒸发器左支撑	01072435	1
10	Ring of Bearing	贯流风叶轴承胶圈	76512044	1
11	Cross Fan Assy	贯流风叶部件	10352395	1
12	Evaporator Assy	蒸发器组件	01002018	1
13	Rear Case	底座	26152440	1
14	Fixing Hook	底座固定扣	26152442	2
15	Rear Pipe Clamp	压管夹	02142204	1
16	Wall Mounting Plate	壁挂板	01252205	1
17	Pipe Clamp	管夹	02142440	1
18	Sensor Suppor	感温头支架	24211121	1
19	Sensor Holder	感温头插片 B	42020063	1
20	Electric Box	电器盒	20102006	1
21	Wire Clamp	电线夹	71010103	1
22	PCB 5F52	控制器 5F52	30025187	1
23	Terminal board	四位接线板 T4B3A	42011233	1
24	Transformer SC21C	电源变压器	43110161	1
25	Motor Clamp	电机固定卡	02112001	2
26	Motor FN25D	电机 FN25D	15012105	1
27	Right Evap Supporter	蒸发器右支撑	01072436	1
28	Drainage Pipe	排水管	05232411	1
29	Motor MP35EA	步进电机 MP35EA	15210104	1
30	Tray Supporter	接水盘中支撑	12122245	2
31	Swing Louver	导风叶片	10512006	12
32	Electric Box Cover	接线盖板	22242201	1
33	Switch Mask	显示灯标牌	60310178	1
34	Indicating Mask	显示接收板	22432200	1
35	Remote Controller	遥控器 Y512	30512505	1
36	Power Cord	电源线	40020333	1
37	Connecting Cable	电源连接线	40020427	1
38	Signal Cable	信号控制线	40032103	1
39	room sensor	室温感温包	39000038	1
40	tube sensor	管温感温包	39000118	1

The data are subject to change without notice.

Feng Xia Series

Table 1-9

No	Description		Part No				Qty
			KF-80G/A1	KFR-80G/A1	KF-80G/NA1	KFR-80G/NA1	
1	Filter	过滤网	11122005	11122005	11122005	11122005	2
2	Front Panel	面板	20002020	20002020	20002020	20002020	1
3	Screw cover	螺钉盖	24252002	24252002	24252002	24252002	3
4	Front Case	面板体	20002021	20002021	20002021	20002021	1
5	Guide Louver	导风板	10512009	10512009	10512009	10512009	1
6	Connecting Lever	导风连杆	10582005	10582005	10582005	10582005	3
7	Water Tray	接水盘	12412061	12412061	12412061	12412061	1
8	Drain Stem	排水口堵头	06812061	06812061	06812061	06812061	1
9	Left Evap Supporter	蒸发器左支撑	01072435	01072435	01072435	01072435	1
10	Ring of Bearing	贯流风叶轴承胶圈	76512044	76512044	76512044	76512044	1
11	Cross Fan Assy	贯流风叶部件	10352397	10352397	10352397	10352397	1
12	Evaporator	蒸发器	01032395	01032395	01032395	\	1
	Evaporator	蒸发器	\	\	\	010323951	1
13	Rear Case	底座	26152440	26152440	26152440	26152440	1
14	Fixing Hook	底座固定扣	26152442	26152442	26152442	26152442	2
15	Rear Pipe Clamp	压管夹	02142204	02142204	02142204	02142204	1
16	Wall Mounting Plate	壁挂板	01252205	01252205	01252205	01252205	1
17	Pipe Clamp	管夹	02142440	02142440	02142440	02142440	1
18	Sensor Suppor	感温头支架	24211121	24211121	24211121	24211121	1
19	Sensor Holder	感温头插片 B	42020063	42020063	42020063	42020063	1
20	Electric Box	电器盒	20102006	20102006	20102006	20102006	1
21	Wire Clamp	电线夹	71010103	71010103	71010103	71010103	1
22	PCB 5F51J	控制器 5F51J	30025581	\	30025581	\	1
	PCB 5F52J	控制器 5F52J	\	30025582	\	30025582	1
23	Terminal board	四位接线板 T4A2A	42011139	42011139	42011139	42011139	1
24	Transformer SC21C	电源变压器	43110161	43110161	43110161	43110161	1
25	Motor Clamp	电机固定卡	02112001	02112001	02112001	02112001	2
26	Motor FN25D	电机 FN25D	15012105	15012105	15012105	15012105	1
27	Right Evap Supporter	蒸发器右支撑	01072436	01072436	01072436	01072436	1
28	Drainage Pipe	排水管	05232411	05232411	05232411	05232411	1
29	Motor MP35EA	步进电机 MP35EA	15210104	15210104	15210104	15210104	1
30	Tray Supporter	接水盘中支撑	12122245	12122245	12122245	12122245	2
31	Swing Louver	导风叶片	10512006	10512006	10512006	10512006	12
32	Electric Box Cover	接线盖板	22242201	22242201	22242201	22242201	1
33	Switch Mask	显示灯标牌	60310178	60310178	60310178	60310178	1
34	Indicating Mask	显示接收板	22432404	22432404	22432404	22432404	1
35	Remote Controller	遥控器 Y512	30512506	30512506	30512506	30512506	1
36	Power Cord	电源线 5G1.5	40020477	40020477	40020477	40020477	1
37	Connecting Cable	电源连接线	40020241	40020241	40020241	40020241	1
38	Siganl Cable	信号控制线	40030327	40030327	40030327	40030327	1
	Siganl Cable	信号控制线	\	40030328	\	40030328	1
39	Room sensor	室温感温包	39000038	39000038	39000038	39000038	1
40	Tube sensor	管温感温包	39000118	39000118	39000118	39000118	1

The data are subject to change without notice.

1.7 Explosive view and spare parts list of outdoor unit

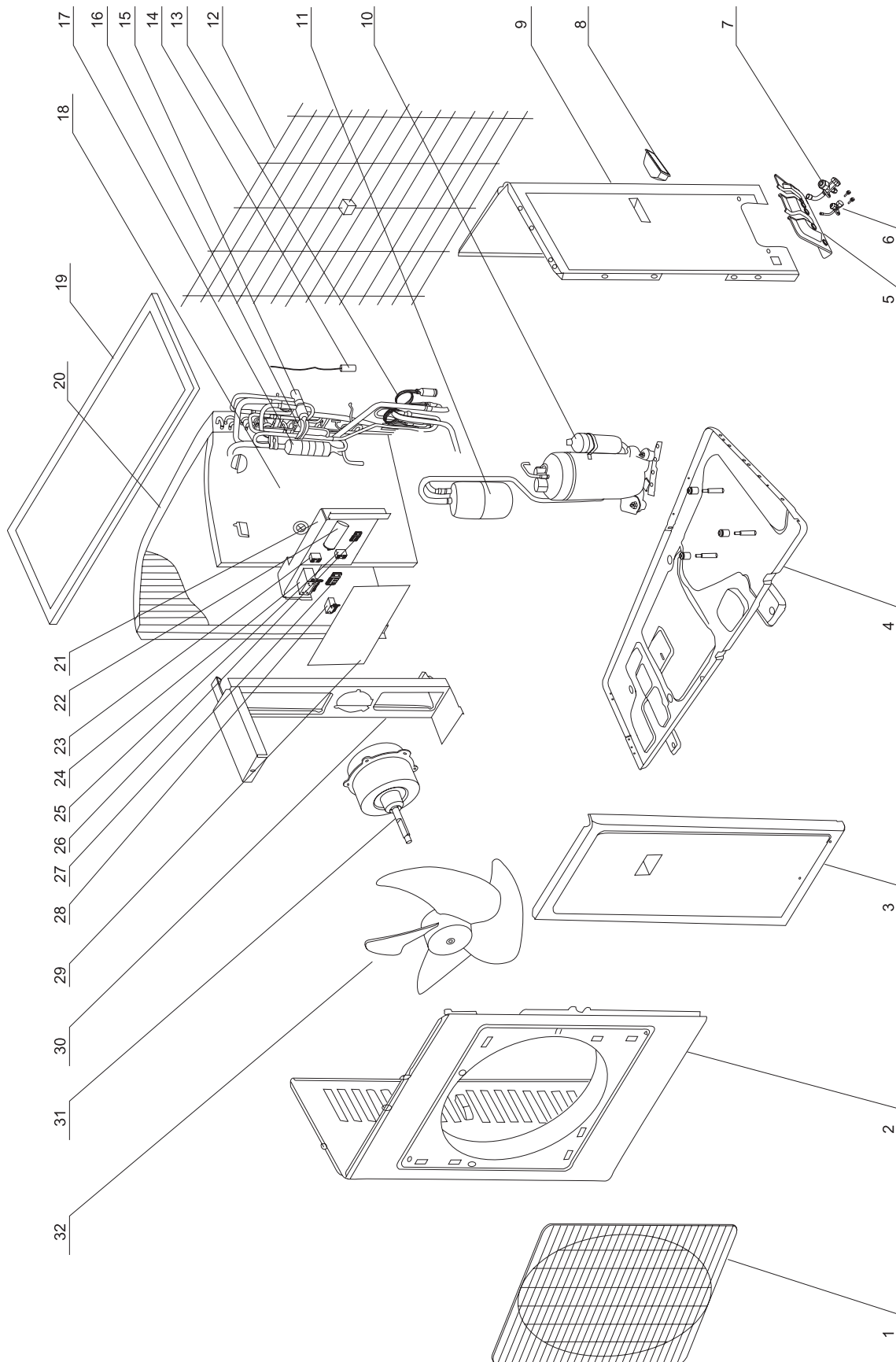

Fig. 1.8

Feng Xia Series

Table 1-10

No	Description		Part No						Qty
			KF-70W/A1	KFR-70W/A1	KF-70W/NA1	KFR-70W/NA1	GSW30-22L/A(O)	GSW30-22R/A(O)	
1	Front Grill	面罩组件	22265250	22265250	22265250	22265250	22265250	22265250	1
2	Front Plate	外罩	01435253	01435253	01435253	01435253	01435253	01435253	1
3	Front Side plate	前侧板组件	01305018	01305018	01305018	01305018	01305018	01305018	1
4	Metal Base	底盘组件	01205264	01205264	01205011	01205011	01205011	01205011	1
5	Valve Support	阀门支架组件	01715002	01715002	01715002	01715002	01715002	01715256	1
6	Liquid Valve Assy	小阀门组件	07105256	07105256	\	\	07105256	07103202	1
	Liquid Valve Assy	小阀门组件	\	\	07105002	07105002	\	\	1
7	Gas Valve Assy	大阀门组件	07105252	07105252	\	\	07105252	07105252	1
	Gas Valve Assy	大阀门组件	\	\	07105007	07105007	\	\	1
8	Handle	把手	26235253	26235253	26235253	26235253	26235253	26235253	1
9	Rear Side Plate	后侧板组件	01305262	01305262	01305262	01305262	01305262	01305262	1
10	Compressor AWG5532EVA	压缩机及其配件	00100509	00100509	\	\	\	\	1
	Compressor C-RN220H5B	压缩机及其配件	\	\	00100063	00100063	\	\	1
	Compressor CRFQ-0250-PFV-501	压缩机及其配件	\	\	\	\	00100011	00100011	1
11	Gas-Liquid Separator	汽液分离器部件	07225001	07225001	07255251	07255251	07255251	07255251	1
12	Rear Grill Assy	网罩(白色)	01475251	01475251	01475251	01475251	01475251	01475251	1
13	Capillary assy	毛细管组件	03003036	03003038	03003039	03003124	03003039	03003123	1
14	Tube Sensor	室外感温头	\	39000006	\	39000006	\	39000006	1
15	4-way Valve	四通阀	\	43000313	\	\	\	43000403	1
	4-way Valve	四通阀	\	\	\	43000305	\	\	1
	4-way Valve Fittings	四通阀配件	\	\	\	\	\	430004001	1
16	Pressure Switch	压力保护开关	\	\	46020011	46020011	46020003	46020003	1
17	Silencer L220	消音器	07245101	07245101	07245005	07245005	07245101	07245101	1
18	Isolation Sheet Assy	隔板组件	01235253	01235253	01235253	01235253	01235253	01235253	1
19	Top Cover Assy	顶盖组件	01255260	01255260	01255260	01255260	01255260	01255260	1
20	Condenser Assy	冷凝器组件	01105030	01103031	\	\	01135030	01135030	1
	Condenser Assy	冷凝器组件	\	\	01135030	01103044	\	\	1
21	Electric Box	电器盒	01415265	01415265	01415265	01415265	01415265	01415265	1
22	Capacitor 45UF\450VAC	压缩机电容	33010740	33010740	\	\	\	\	1
	Capacitor 40UF\440VAC	压缩机电容	\	\	33010722	33010722	\	\	1
	Capacitor 35UF\450VAC	压缩机电容	\	\	\	\	33000027	33000027	1
23	Capacitor 3UF\450VAC	风机电容	33010027	33010027	33010027	33010027	\	\	1
	Capacitor 3UF\450VAC	风机电容	\	\	\	\	33010021	33010021	1
24	Contacto C JX9B-255	双极交流接触器	44010221	44010221	\	\	44010221	44010221	1
	Contacto C JX9B-255\01	双极交流接触器	\	\	44010222	44010222	\	\	1
25	Capacitor 88-108UF	启动电容	33010603	33010603	\	\	\	\	1
	Capacitor 145-174UF	启动电容	\	\	\	\	33010604	33010604	1
26	Terminal Board 2-8	接线板 2-8	42011103	42011103	42011103	42011103	42011103	42011103	1
27	Terminal Board	三位接线板	42011102	42011102	42011102	42011102	42011102	42011102	1
28	Relay 3 ARR3U10AS3\JDQ1-6	启动继电器	44020306	44020306	44020306	44020306	44020306	44020306	1
29	Electric Box Cover	电器盒上盖板	01415255	01415255	01415255	01415255	01415255	01415255	1
30	Motor Support	电机支架组件	01705251	01705202	01705251	01705251	01705251	01705251	1
31	Motor LW60B	电机 LW60B	15015205	15015205	15015205	15015205	\	\	1
	Motor FW60F	电机 FW60F	\	\	\	\	15013250	15013250	1
32	Axial Flow Fan	轴流风叶	10335253	10335253	10335254	10335254	10335254	10335254	1

The data are subject to change without notice.

Feng Xia Series

Table 1-11

No.	Description		Part No.	Qty
			KFR-70W/A1-12405	
1	Front Grill	面罩组件	22265251	1
2	Front Plate	外罩	01435253	1
3	Front Side plate	前侧板组件	01305018	1
4	Metal Base	底盘组件	01205011	1
5	Valve Support	阀门支架组件	01715002	1
6	Liquid Valve Assy	小阀门组件	07105256	1
7	Gas Valve Assy	大阀门组件	07105252	1
8	Handle	把手	26235253	1
9	Rear Side Plate	后侧板组件	01305262	1
10	Compressor AWG5532EVA	压缩机及其配件	00100509	1
11	Gas-Liquid Separator	汽液分离器部件	07225001	1
12	Rear Grill Assy	网罩(白色)	01475251	1
13	Capillary assy	毛细管组件	03003038	1
14	Tube Sensor	室外感温头	39000006	1
15	4-way Valve	四通阀	43000403	1
	4-way Valve Fittings	四通阀配件	43000400	1
17	Silencer L220	消音器	07245101	1
18	Isolation Sheet Assy	隔板组件	01235253	1
19	Top Cover Assy	顶盖组件	01255260	1
20	Condenser Assy	冷凝器组件	01135030	1
21	Electric Box	电器盒	01415265	1
22	45UF/450VAC	压缩机电容	33010740	1
23	Capacitor 3UF/450VAC	风机电容	33010027	1
24	Contacto CJX9B-25S	双极交流接触器	44010221	1
25	Capacitor 88-108UF	启动电容	33010603	1
26	Terminal Board 2-8	接线板 2-8	42011103	1
27	Terminal Board	三位接线板	42011102	1
28	Relay3ARR3U10AS3/JDQ1-6	启动继电器	44020306	1
29	Electric Box Cover	电器盒上盖板	01415255	1
30	Motor Support	电机支架组件	01705202	1
31	Motor LW60B	电机 LW60B	15015205	1
32	Axial Flow Fan	轴流风叶	10335254	1

The data are subject to change without notice.

Feng Xia Series

Table 1-12

No.	Description		Part No				Qty
			KF-80W/A1	KFR-80W/A1	KF-80W/NA1	KFR-80W/NA1	
1	Front Grill	面罩组件	22265250	22265250	22265250	22265250	1
2	Front Plate	外罩	01435254	01435254	01435254	01435254	1
3	Front Side plate	前侧板组件	01305018	01305018	01305018	01305018	1
4	Metal Base	底盘组件	01205433	01205433	01205433	01205433	1
5	Valve Support	阀门支架组件	01715001	01715001	01715001	01715001	1
6	Liquid Valve Assy	小阀门组件	07105255	\	\	\	1
	Liquid Valve Assy	小阀门组件	\	07105002	07105002	07105002	1
7	Gas Valve Assy	大阀门组件	07105251	07105251	07105251	07105251	1
8	Handle	把手	26235252	26235252	26235252	26235252	1
9	Rear Side Plate	后侧板组件	01305262	01305262	01305262	01305262	1
10	Compressor C-SB263H8A	压缩机及其配件	00100077	00100077	\	\	1
	Compressor C-SBN263H8A	压缩机及其配件	\	\	00100160	00100160	1
11	Gas-Liquid Separator	汽液分离器部件	07255201	07255201	07255201	07255201	1
12	Rear Grill Assy	网罩(白色)	01475251	01475251	01475251	01475251	1
13	Capillary assy	毛细管组件	03003261	03003314	03003261	03003314	1
14	Tube Sensor	室外管温感温包	39000121	39000121	39000121	39000121	1
15	4-way Valve	四通阀	\	43000325	\	43000325	1
	4-way Valve Fittings	四通阀配件	\	\	\	\	1
16	Pressure Switch	压力保护开关	46020003	46020003	46020003	46020003	1
17	Silencer L220	消音器	\	\	\	\	\
18	Isolation Sheet Assy	隔板组件	01235253	01235253	01235253	01235253	1
19	Top Cover Assy	顶盖组件	01255260	01255260	01255260	01255260	1
20	Condenser Assy	冷凝器组件	01135202	\	01135202	01135202	1
	Condenser Assy	冷凝器组件	\	01133058	\	\	1
21	Electric Box	电器盒	01415205	01415205	01415205	01415205	1
22	Capacitor 45UF/450VAC	压缩机电容	\	\	\	\	\
23	Capacitor 3UF/450V	风机电容	33010027	33010027	33010027	33010027	1
24	Contactore LC1D1801M7C	交流接触器	44010211	44010211	44010211	44010211	1
25	Capacitor 88-108UF	启动电容	\	\	\	\	\
26	Terminal Board 2-8	接线板2-8	42011103	42011103	42011103	42011103	1
27	Terminal Board GT8F0A1	接线板	42011036	42011036	42011036	42011036	1
28	Relay 3ARR3U10AS3JDQ1-6	启动继电器	\	\	\	\	\
29	Electric Box Cover	电器盒上盖板	01415255	01415255	01415255	01415255	1
30	Motor Support	电机支架组件	01705251	01705251	01705251	01705251	1
31	Motor LW60L	电机 LW60L	15013063	\	15013063	\	1
	Motor LW70A	电机 LW70A	\	15015210	\	15015210	1
32	Axial Flow Fan	轴流风叶	10335253	10335253	10335253	10335253	1

The data are subject to change without notice.

1.8 Circuit diagram

These circuit diagrams are subject to change Without notice.
Please refer to the ones stuck on the machines.

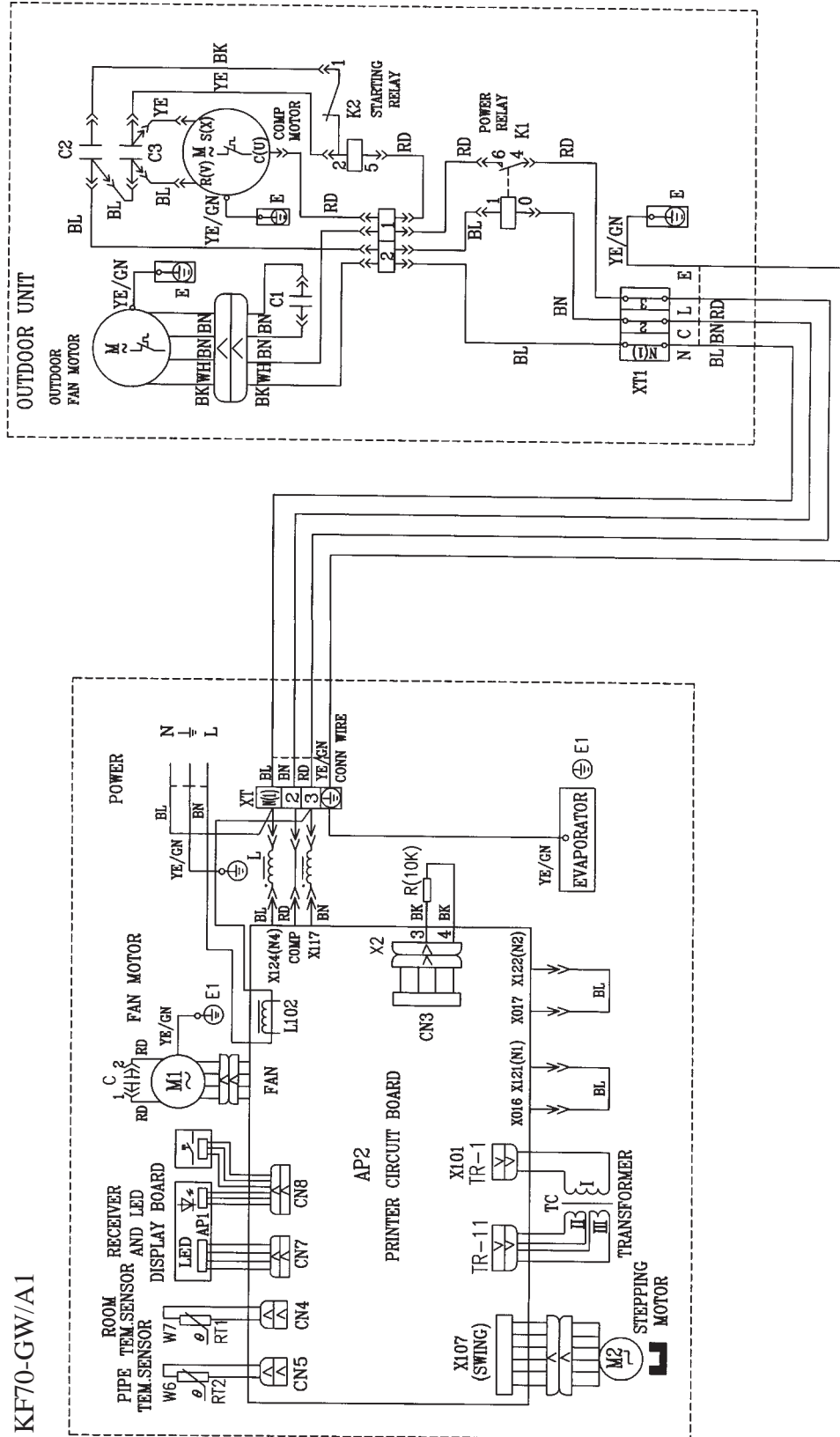

Fig. 1.9

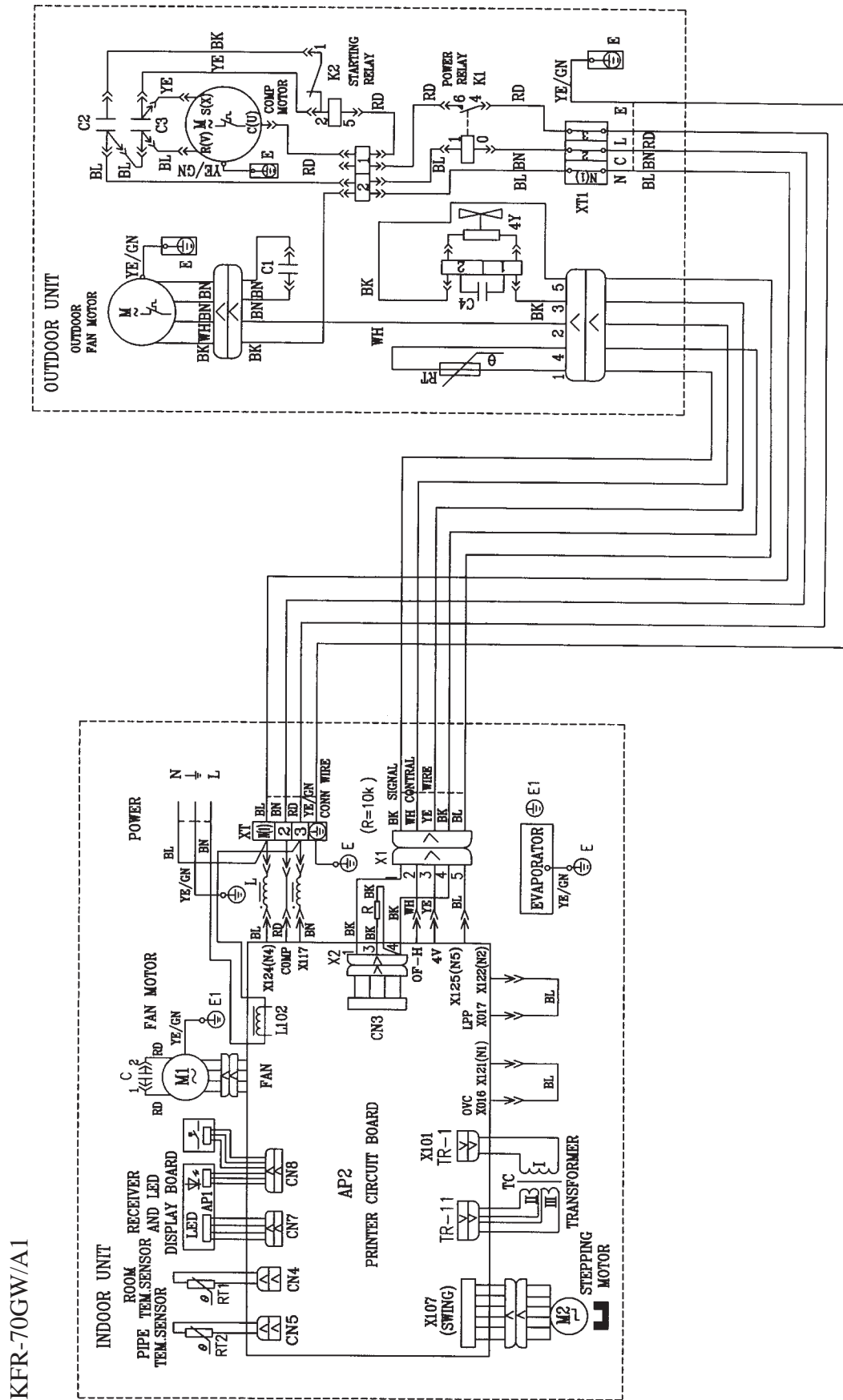

Fig. 1.10

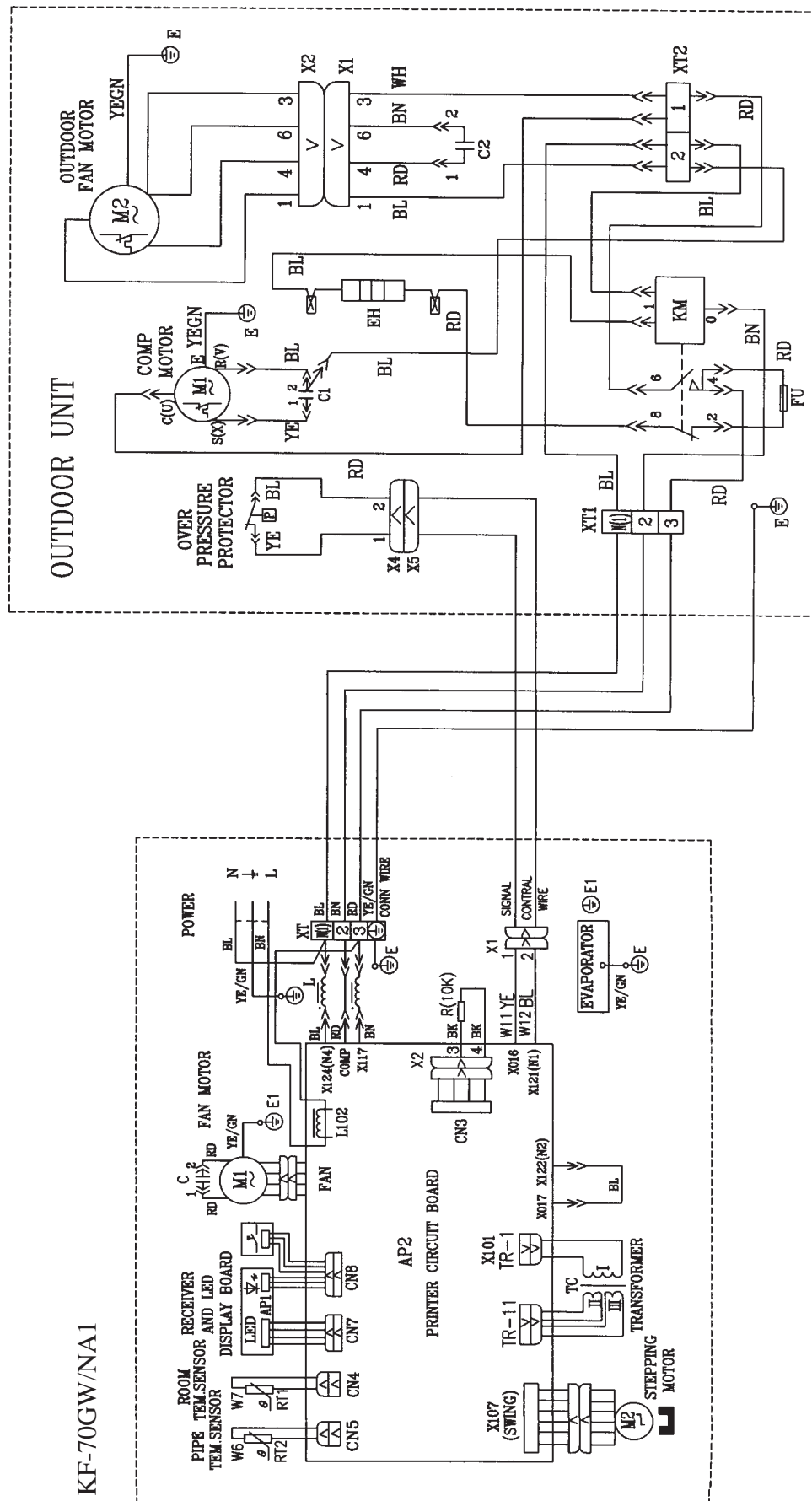

Fig. 1.11

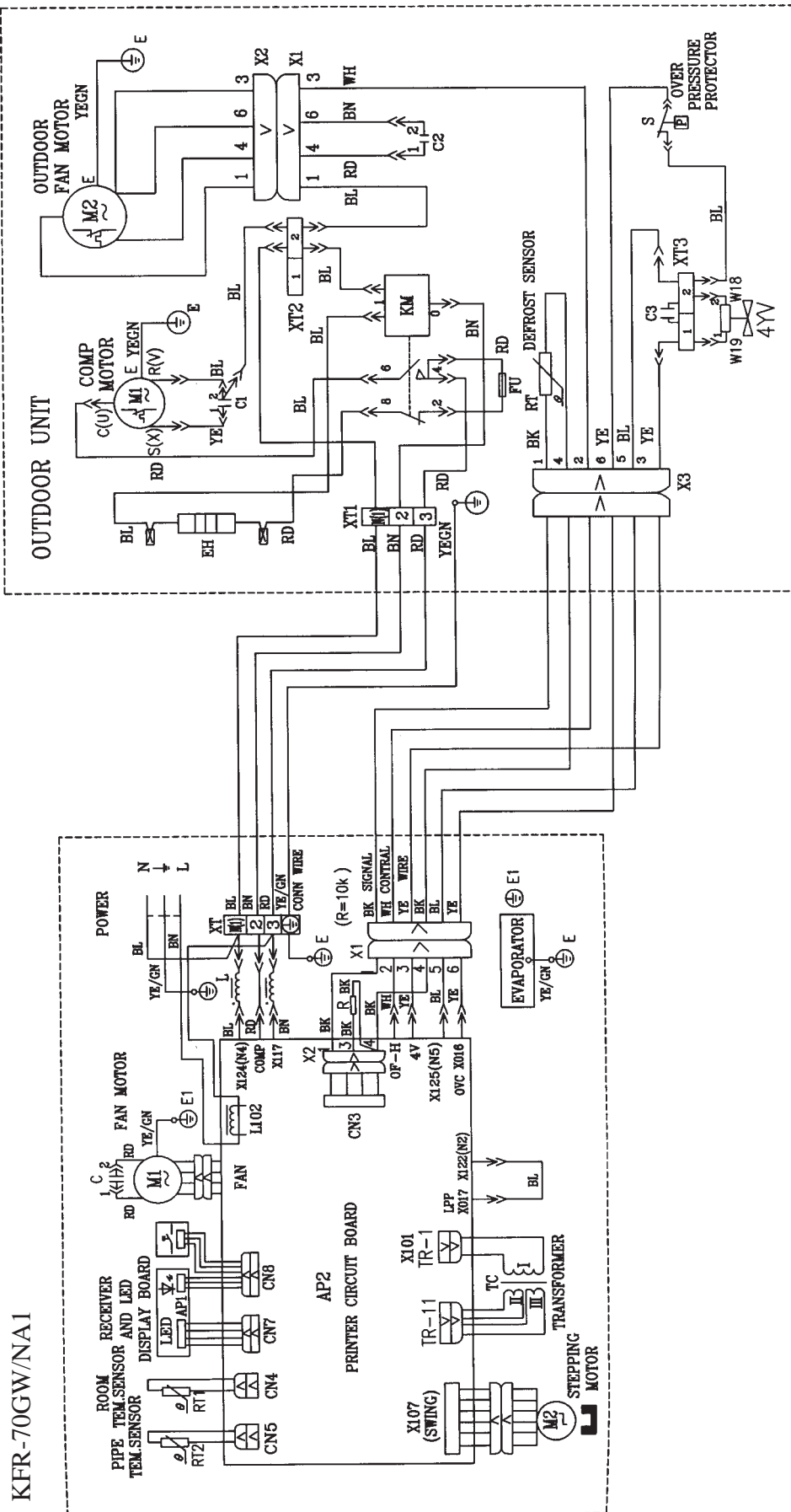

Fig. 1.12

GSW30-22L/A

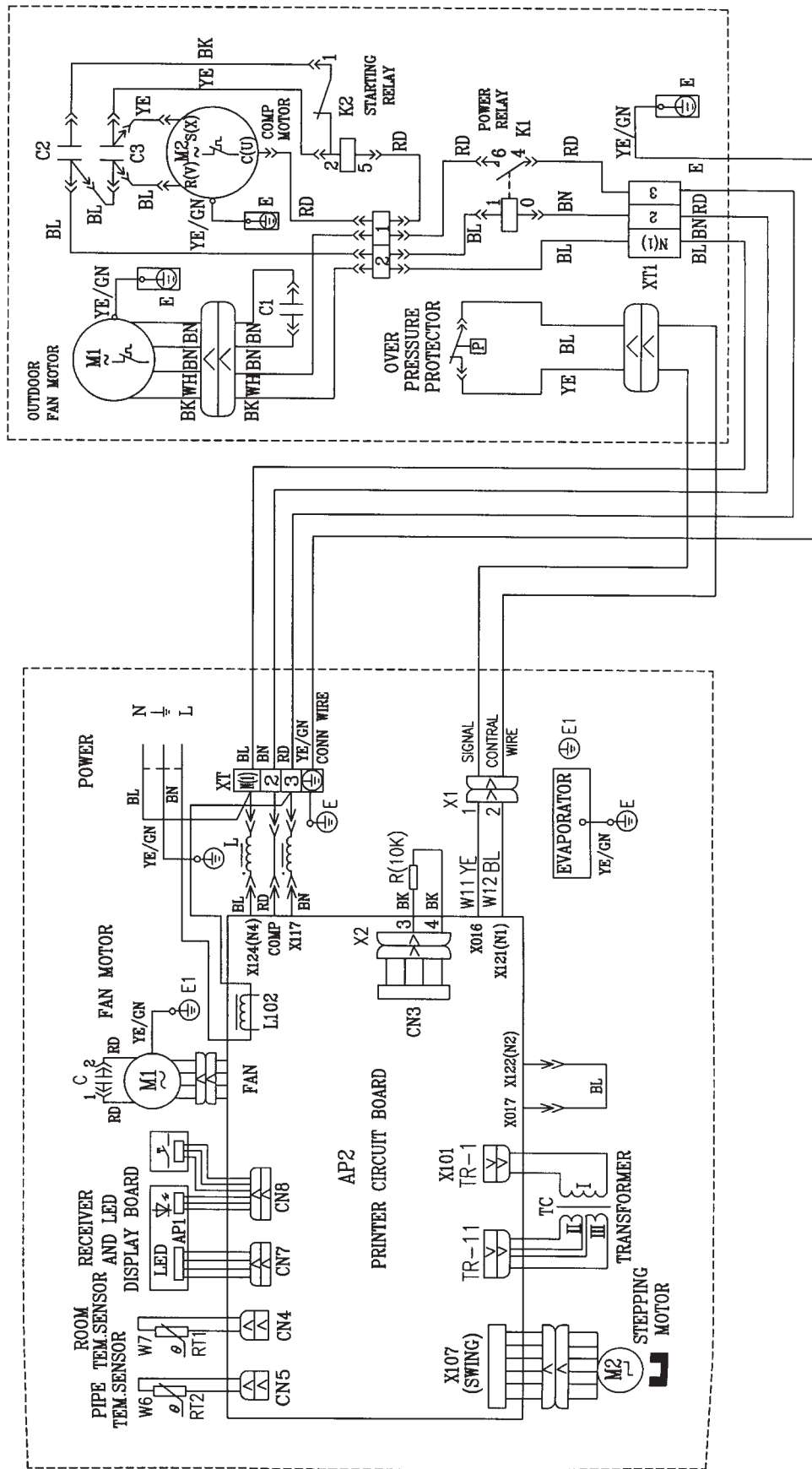

Fig. 1.13

G5W30-22R/A

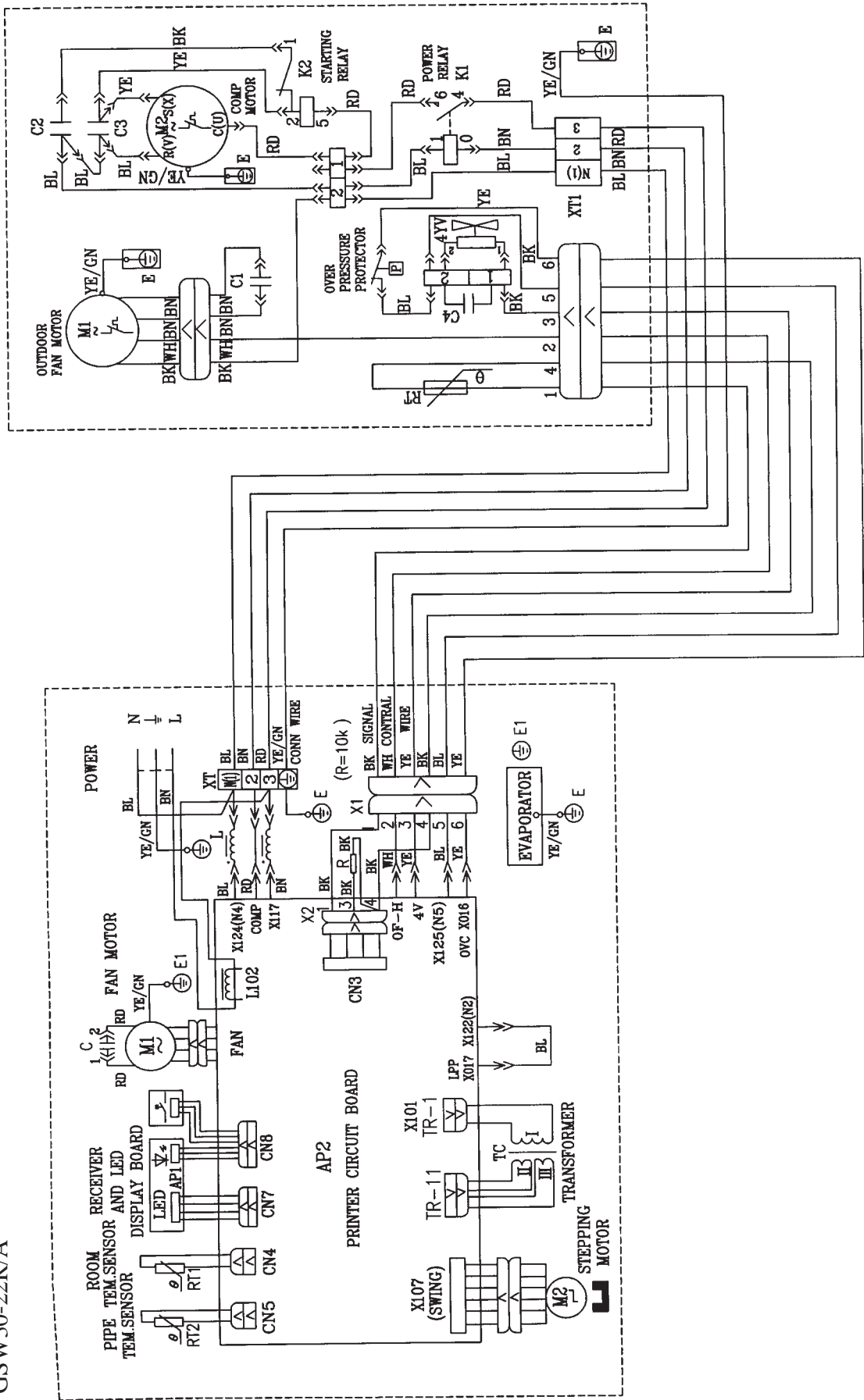

Fig. 1.14

KFR-70GW/A1-12405

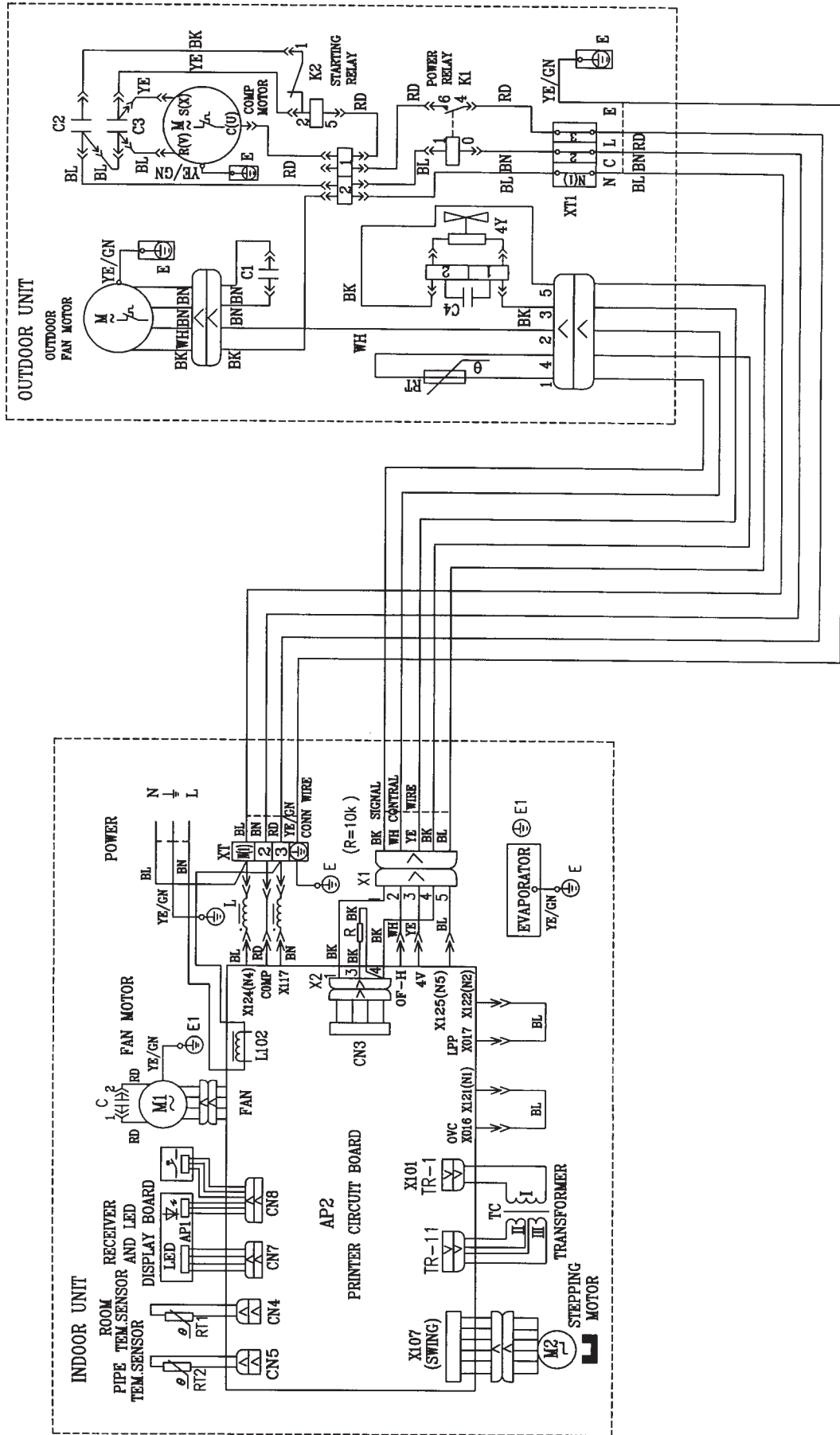

Fig. 1.15

KF-80GW/A1
KF-80GW/NA1

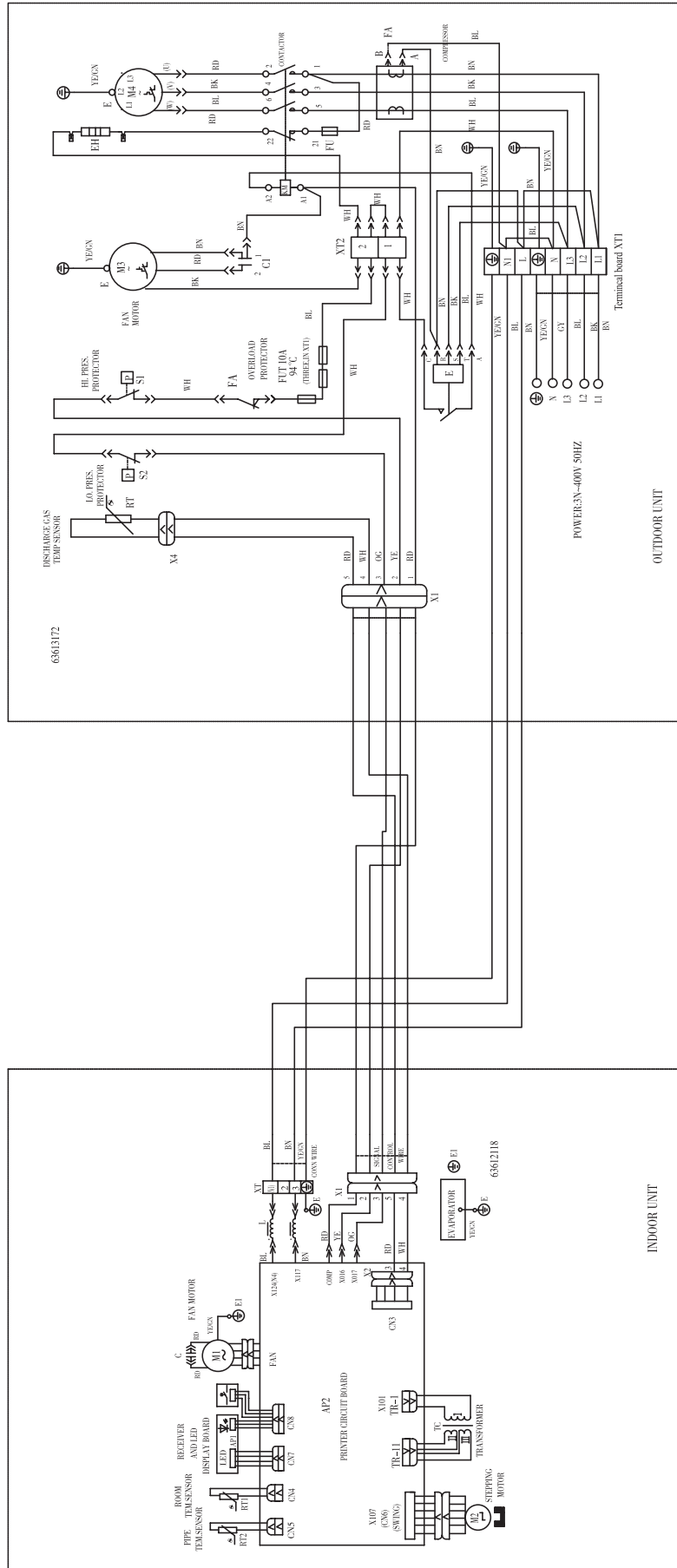

Fig. 1.16

KFR-80GW/A1
KFR-80GW/NA1

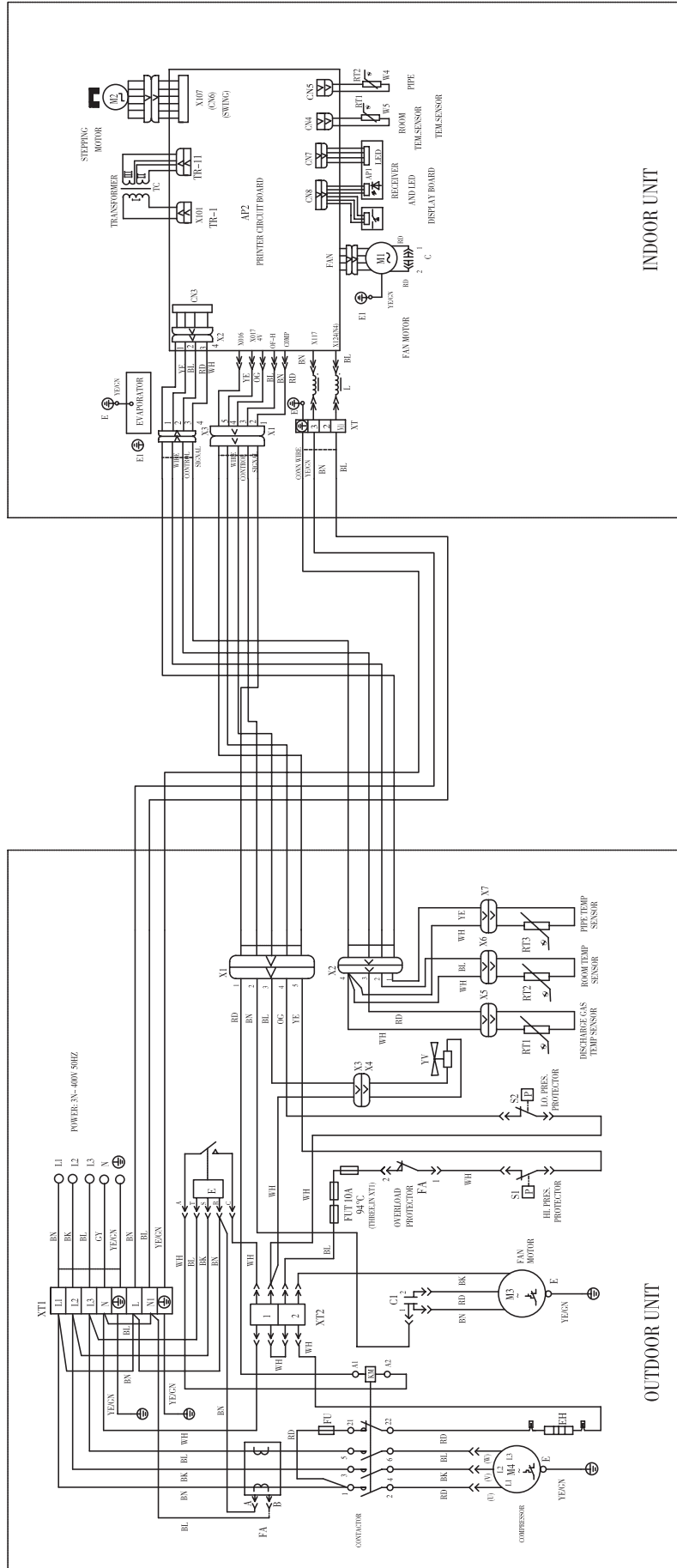

Fig. 1.17

1.9 PCB function manual

PCB function manual of Feng Xia Split Air-conditioner

1. Running mode:

1) AUTO; 2) COOL; 3) HEAT; 4) DRY; 5) FAN.

2. Controlling contents:

- 1) indoor unit fan motor(high, middle and low speed);
- 2) sweep fan motor;
- 3) outdoor unit fan motor(high and low);
- 4) compressor;
- 5) reversing valve;
- 6) electrical heater;

3. The parameter to be input:

- 1) the ambient temperature of the indoor unit (shorten form is T_{in});
- 2) the evaporator temperature of the indoor unit (shorten form is T_{eva});
- 3) the condenser temperature of the outdoor unit (shorten form is T_{con});
- 4) the ambient temperature of the outdoor unit (shorten form is T_{out});
- 5) the temperature of the gas output from the compressor (shorten form is T_{output}).

4. The different controlling mode for the different function mode:

Under all of the modes, the compressor will continue work for 6 min once it starts. And it will be restart in 3min after it stops.

1) Cooling mode:

If $T_{in} \geq T_{set}+1^{\circ}\text{C}$, cooling mode act, compressor and outdoor unit run, and indoor unit run in the set speed;

If $T_{in} \leq T_{set}-1^{\circ}\text{C}$, the unit will be stop from cooling mode, compressor and outdoor unit stop, and indoor unit still run in the set speed;

If $T_{set}-1^{\circ}\text{C} < T_{in} < T_{set}+1^{\circ}\text{C}$, keep running in the old mode;

In the cooling mode, the range of T_{set} is $16^{\circ}\text{C}\sim 30^{\circ}\text{C}$.

2) Drying mode:

If $T_{in} > T_{set}+2^{\circ}\text{C}$, drying mode act, compressor, indoor unit fan motor and outdoor unit fan motor run, The indoor unit fan motor runs in low speed;

If $T_{set}-2^{\circ}\text{C} \leq T_{in} \leq T_{set}+2^{\circ}\text{C}$, compressor, indoor unit fan motor and outdoor unit fan motor run for 6min, then stop for 4min, then run by this cycle. The indoor unit fan motor runs in low speed;

If $T_{in} < T_{set}-2^{\circ}\text{C}$, compressor, outdoor unit fan motor and indoor unit fan motor stop.

In drying mode, the range of T_{set} is $16^{\circ}\text{C}\sim 30^{\circ}\text{C}$.

3) Heating mode:

If $T_{in} \leq T_{set}-1^{\circ}\text{C}$, heating mode act, reversing, compressor and outdoor unit fan motor run, indoor unit fan motor runs in the set speed and the condition of avoiding the cold wind;

If $T_{in} \geq T_{set} + 1^\circ\text{C}$, compressor and outdoor unit fan motor stop, reversing valve is still electric, the indoor unit fan motor runs in the set speed and flow the rest heat;

If $T_{set} - 1^\circ\text{C} < T_{in} < T_{set} + 1^\circ\text{C}$, keep running in the old mode;

In the heating mode, the range of T_{set} is $16^\circ\text{C} \sim 30^\circ\text{C}$.

In the heating mode, the 4-way valve will be electroless in 2min after the unit is turned off.

The conditions of avoiding cold wind:

Once the compressor work, either $T_{eva} \geq 42^\circ\text{C}$ or the compressor running for over 30sec, the indoor unit fan motor run in the old speed, 6min later, if $T_{eva} \leq 35^\circ\text{C}$, indoor unit fan motor run in low speed, if $35^\circ\text{C} < T_{eva} < 42^\circ\text{C}$, keep speed.

The conditions of flowing hot wind:

Once the compressor is stop, the indoor unit fan motor runs in low speed and will stop too in 90sec.

The conditions of beginning defrosting:

After the unit continue heating for 44min or if $T_{con} \leq -5^\circ\text{C}$ for 1min, the defrosting mode act, running light flash, reversal valve, indoor and outdoor unit stop.

If there is electrical heater in the unit, then it will be stop first and the reversal valve, the indoor and outdoor unit stop in 10sec.

The conditions of stopping defrosting:

After the unit continue defrosting for 10min or if $T_{con} \geq 10^\circ\text{C}$, the defrosting stop, the reversal valve, the outdoor unit run, and the indoor unit fan motor will run in the the condition of avoiding the cold wind.

The working condition of electrical heater:

When the indoor unit is running in high or middle speed, and $T_{eva} \leq 49^\circ\text{C}$ and $T_{in} \leq 25^\circ\text{C}$, electrical heater act.

When the indoor unit is stop, or $T_{eva} \geq 54^\circ\text{C}$ or $T_{in} \geq 28^\circ\text{C}$, or $T_{in} \geq T_{set}$, the electrical heater stop and will restart in 2min.

4) Fanning mode:

The indoor unit fan motor runs in the set fan speed:

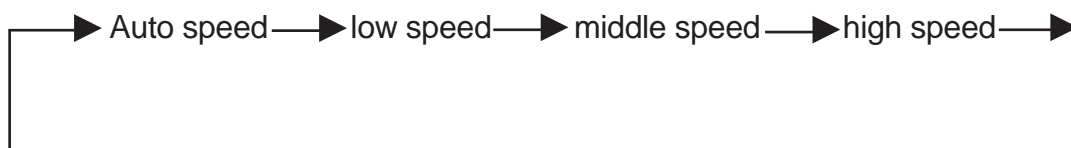

The range of is $16^\circ\text{C} \sim 30^\circ\text{C}$.

5) Auto mode:

It runs according the T_{in} .

If $T_{in} > 26^\circ\text{C}$, cooling mode act, the T_{set} is 26°C .

If $T_{in} < 20^\circ\text{C}$, heating mode act, the T_{set} is 20°C .

If $20^\circ\text{C} \leq T_{in} \leq 26^\circ\text{C}$, running in the old mode.

If the unit is cooling only, if $T_{in} < 20^{\circ}\text{C}$, fanning mode act, the T_{set} is 20°C .

Once the each mode act, it will be in 30sec to change to the auto mode according the T_{in} .

5. Timer and sleep mode:

1) Sleep mode:

If it is cooling or drying, in 1hour of the beginning, the T_{set} will be increased 1°C , and it will be increased 1°C after 2hour, then the unit runs in this temperature.

If it is heating, in 1hour of the beginning, the T_{set} will be decreased 1°C , and it will be decreased 1°C after 2hour, then the unit runs in this temperature.

There is no sleep mode when fanning and auto mode act.

2) Timer for Turn on:

The unit is stop when the timer for turn on is acted, when it is time to turn on, the controller will act in the set mode. The distance of setting twice is 0.5hour and the range time is 0.5~24hour.

3) Timer for Turn off:

The unit is run when the timer for turn off is acted, the unit is stop when it time to turn off. He distance of setting twice is 0.5hour and the range time is 0.5~24hour.

6. Other functions:

1) Sweeping:

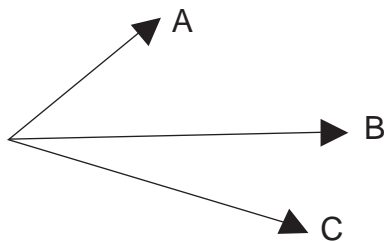

a. When unit is turned on, guider revolve anti-clockwise to A then revolve deasil to C.

b. When unit is turned on (sweeping mode does not act), guider revolve to A then stop; if sweeping mode act, guider revolve between A and B. Now, guider can be stop or not by remote control; it is valid only when indoor unit fan motor run.

c. When unit is stop, guider revolve to C to shut the air-let.

2) Buzzer function:

It will be act when the controller is turned on or received a right signal.

3) Auto fan speed of indoor unit:

When heating act:

If $T_{in} \geq T_{set}$, the indoor unit fan motor runs in low fan speed;

If $T_{set}-3^{\circ}\text{C} \leq T_{in} < T_{set}$, it is middle fan speed;

If $T_{in} < T_{set}-3^{\circ}\text{C}$, it is high fan speed.

When cooling act:

If $T_{in} \leq T_{set}$, it is low fan speed;

If $T_{set} < T_{in} \leq T_{set}+3^{\circ}\text{C}$, it is middle fan speed;

If $T_{in} > T_{set}+3^{\circ}\text{C}$, it is high fan speed.

When fanning act:

If $T_{in} \leq T_{set}$, it is low fan speed;

If $T_{set} < T_{in} \leq T_{set}+3^{\circ}\text{C}$, it is middle fan speed;

If $T_{in} > T_{set}+3^{\circ}\text{C}$, it is high fan speed.

The indoor unit fan motor will run by the rules till it runs for 30sec after the unit is turned on.

4) Indicator light:

Running indicator light (red):

It flashes once when the unit is turned on, light is turned on when the unit is turned on and turned off when the unit is turned off.

Mode indicator light (yellow/ green):

It is yellow when it is heating.

It is green when it is cooling.

It is turned off when others modes act.

7. The protecting functions:

1) The protection of avoiding freeze:

In cooling or drying mode, after compressor run for 10min, if $T_{eva} \leq 0^{\circ}\text{C}$ for 3min, running indicator light flash, compressor stop, outdoor unit fan, indoor unit fan and sweeping fan keep the old mode. If $T_{eva} \geq 10^{\circ}\text{C}$, and compressor is stop for 3min, running indicator light turn off, PCB run in the set mode.

Buttons won't be screened when protection of avoiding freeze act.

2) Compressor high voltage protection:

All of the load will be stop when the protection act for 3sec, screen all of the buttons and control signal, running indicator light flash; when the protection is canceled for 6sec, all the screen will be canceled, running indicator light still flash. Press the "ON/OFF" button to turn off the light. Press the button once more to restart.

3) Low voltage protection:

a. In 3min later after compressor start, if the low voltage switch is turn off for 3min, then unit stop, running indicate light flash, 3min later, resume to run automatically. If this protection act twice, running indicate light flash and can not resume automatically in order to mention the user that the unit is leakage; it must press the ON/OFF button to stop the unit and press once more to restart;

b. It won't test the low voltage switch digital when defrosting mode act until 10min later after defrosting stop;

c. Press auto and test buttons together can shield the digital of low-voltage to collect the gas, 6min later or press ON/OFF button to resume test automatically;

d. If $T_{out} \leq 0^{\circ}\text{C}$ when heating, shield the test function;

e. If compressor stop and outdoor unit fan motor run when heating, shield the digital of low-voltage until outdoor unit fan motor run;

f. Compressor stop and low-voltage switch turn off for 30sec, unit stop and running indicate light flash, unit can not restart automatically unless press ON/OFF button twice.

4) Protection for avoiding too high temperature of outlet pipe:

After compressor start, if $T_{out} \geq T_2$ ($T_2=120^\circ\text{C}, 125^\circ\text{C}, 130^\circ\text{C}$), or if there is any trouble in outlet pipe sensor, running indicate light flash.

If $T_{in}=T_{set}$, unit stop.

If $T_{out} < 90^\circ\text{C}$ after compressor stop for 3min, unit restart.

Unit can not restart unless this protection act twice. Running indicate light flash.

Press ON/OFF button twice to run the unit in set mode.

5) Protection for avoiding too high temperature of indoor:

If $T_{eva} \geq 58^\circ\text{C}$ for 4sec when heating, outdoor unit fan motor stop, if $T_{eva} \leq 52^\circ\text{C}$, outdoor unit fan motor restart.

6) Protection for low-voltage

If current $\geq 25\text{A}$ for 3sec after compressor start, unit will stop when $T_{in}=T_{set}$, then restart in 3min later. If this protection act more than 6 times, unit can not restart automatically, it must restart it by pressing ON/OFF button.

8. Buttons:

If unit is for cooling only, when press "heating" button, it just fan.

1) TEST button:

Press this button when unit is stop, cooling mode act, indoor and outdoor unit fan motor run in high speed. Press this button more than 1sec, heating mode act, indoor and outdoor unit fan motor run in high speed. If $T_{in} \leq -10^\circ\text{C}$ or $T_{in} \geq 80^\circ\text{C}$, buzzer ring; if $T_{eva} \leq -13^\circ\text{C}$ or $T_{in} \geq 74^\circ\text{C}$, buzzer ring.

Press this button when unit is running, unit will stop.

2) AUTO button:

Press this button when unit is stop, unit will run in auto mode. Unit will stop if press this button when unit is running,

9. Memory function:

Memory include: mode, sweep, T_{set} , set speed.

Unit will restart in old mode by memory function after power is turned off.