



Digital Multi Connected Air Conditioners Owner's Manual

Models:

GMV-R200W2/B	GMVL-R200W2/B
GMV-R220W2/B	GMVL-R220W2/B
GMV-R260W2/B	GMVL-R260W2/B
GMV-R300W2/B	GMVL-R300W2/B
GMV-R420W3/A	GMVL-R420W3/A
GMV-R560W4/A	GMVL-R560W4/A
GMV-R620W4/A	GMVL-R620W4/A

Please read this manual carefully before operation

Performance parameters for the units

● Performance Parameters for Outdoor Units

Item \ Model		GMV(L)-R200W2/B	GMV(L)-R220W2/B	GMV(L)-R260W2/B	GMV(L)-R300W2/B	GMV(L)-R420W3/A	GMV(L)-R560W4/A	GMV(L)-R620W4/A
Cooling capacity (W)		20000	22000	26000	30000	42000	56000	62000
Heating capacity (W)		23000	24000	28000	33500	46000	60000	66000
Noise (dB (A))		≤58	≤58	≤58	≤58	≤59	≤60	≤60
Compressor		Digital vortex × 1 +fixed speed vortex × 1	Digital vortex × 1 +fixed speed vortex × 1	Digital vortex × 1 +fixed speed vortex × 1	Digital vortex × 1 +fixed speed vortex × 1	Digital vortex × 1 +fixed speed vortex × 2	Digital vortex × 1 +fixed speed vortex × 3	Digital vortex × 1 +fixed speed vortex × 3
R22 Charge volume		kg	14	14	16	16	35	40
Power supply		380V 3N~ 50Hz	380V 3N~ 50Hz	380V 3N~ 50Hz	380V 3N~ 50Hz	380-400V 3N~ 50Hz	380-400V 3N~ 50Hz	380-400V 3N~ 50Hz
Overload Power	Cooling	kW	6.8	6.8	9.85	10.5	14.0	18.7
	Heating	kW	6.9	6.9	9.85	10.5	14.4	18.8
Overload current	Cooling	A	12.3	12.3	16.0	19.0	24.7	33.0
	Heating	A	12.5	12.5	16.0	19.0	25.4	33.1
Fan motor	Input power	kW	1.1	1.1	1.1	1.1	1.1×2	1.1×2
	Running current	A	2.2	2.2	2.2	2.2	2.2×2	2.2×2
Dimension (mm) (W×D×H)		990×840 ×1695	990×840 ×1695	990×840 ×1695	990×840 ×1695	1980×840 ×1675	1980×840 ×1675	1980×840 ×1675
Water-proof level		IPX4	IPX4	IPX4	IPX4	IPX4	IPX4	IPX4
Climate type		T1	T1	T1	T1	T1	T1	T1
Connection pipe	Gas pipe	mm	φ 25.4	φ 25.4	φ 28.6	φ 28.6	φ 34.8	φ 41.3
	Liquid pipe	mm	φ 12.7	φ 12.7	φ 12.7	φ 12.7	φ 16.3	φ 19.05
	Connection way		Brazing	Brazing	Brazing	Brazing	Brazing	Brazing
Weight		kg	260	260	280	300	560	600
Recommended power cord		mm ² x piece	4.0×5	4.0×5	6.0×5	6.0×5	10.0×5	10.0×5

Notes: 1. The cooling-only unit (Model GMVL) does not have the item of rating heating capacity

2. The rating cooling capacity is tested under the condition of indoor temp. 27°CDB、19°CWB, outdoor temp. 35°CDB,24°CWB.

3. The rating heating capacity is tested under the condition of indoor temp. 20°CDB、15°CWB, outdoor temp. 7°CDB,6°CWB.

4. The filling amount of the refrigerant R22 does not take into account of the connecting pipes. During the practical installation, additional filling will be needed in accordance with the site conditions.

5. If the data wasn't the same as Rating Label, please refer to the Rating Label.



The instructions before use

- ☆ When operating, the general capacity of the cooperating indoor unit should not larger than the outdoor unit's. Otherwise, it will cause the shortage of cooling (heating) capacity.
- ☆ The power supply of the indoor unit must be the unified power supply. The indoor unit cannot have the individual power switch, and all the indoor unit can only be controlled by one main power control. Disconnect the main power of all the indoor units before cleaning.
- ☆ In order to turn on the units successfully, the main power switch should be opened 8 hours before the operation.
- ☆ After receiving the turn off signal, every indoor unit will continue to work for 20-70sec to make use of the rest cool air or the rest heat air in the heat exchanger, while preparing for the next operation. And this is normal.
- ☆ When the closed operating mode of the indoor unit are clash with the operating mode of the outdoor unit, the malfunction light will glimmer after 5sec on the indoor unit or remote controller showing that the operation clash, then the indoor unit will stop. At this time, change the operation mode of the indoor unit to the one that would not clash with the outdoor operating mode to make the operation normal. The cooling mode is not clash with the dry mode, while the fan mode is not clash with any mode.
- ☆ When installing, the transmission cord can not twisted with the power cord, and they should be separated and the space between them should at least 2cm. Otherwise it may cause the abnormal of the transmission of the unit.

Safety information

1. Please read this manual carefully before use this unit, and operate it correctly according to the guide in this manual.

2. Please take specially note to the meaning of these two marks:



Note!: This mark means that it may cause casualty or badly heart if the operation is incorrect.



Note!: This mark means that it may cause casualty or property loss if the operation is incorrect.



Note!

- Please contact the special nominated repair agency to install the unit. The incorrect installation may cause water leakage, electric shock and fire etc..
- Please make sure that the unit is installed in the place that can bear the weight of it adequately. If the place is not strong enough, the air conditioner may drop and cause casualty event.
- The drainage pipe should be installed correctly according to the installation instruction to assure correct drain, and the heat preservation should be take to prevent condensation. The incorrect installation of pipe may lead leakage and bedew the things in house.
- Don't use or store any flammability, easy explod or venomous hazardous thing beside the air conditioner.
- Cut down the main power switch immediately if malfunction (such as smell the borning odor etc.) happened.
- Keep the air ventilation to prevent the leakage of oxygen in the room.
- Don't insert your hands or other things into the discharge outlet or inlet grill
- Please check if there are spoil in the bracket after the long duration frequently.
- Do not refit the conditioner. Please contact the agency or prefectional personnel to repair or move the conditioner.



Note!

- Before installation, please check if the power is the same with the power required on the nameplate, and check the safety of the power.
- Please check and make sure that the corb, drainage pipe and tubings are connected in the correct way to prevent leakage of water, refregerant, electric shock or fair.
- The main power must connectable to the earth in order to assure the conditioner earthing effectively and to prevent electric shock. Please don't connect the earthing line with the gas pipe, water pipe, lightening rod or the connecting line of telephone.
- The air conditioner should be turned off at least after 5 mins'operation; otherwise it would affect the duration of the unit.
- Don't let the children operate the air conditioner.
- Please don't operate the unit by wet hand.
- Please turn off the main power of the unit before cleaning the conditioner or change the filter.
- Please cut off the main power if the conditioner will be used for a long time.
- Please don't let the conditioner expose directly in the envirenment that can be corrupt easily, like the envirenment with water or high humidity.
- Please don't step on the unit or put things on the unit.
- The leaking resistance test should be took after the installation.

Performance parameters for the units

Rating Operational Status for Air Conditioning Units

	Indoor side status		Outdoor side status	
	Dry bulb temperature°C	Wet bulb temperature°C	Dry bulb temperature°C	Wet bulb temperature°C
Rating cooling	27	19	35	24
Rating heating	20	15	7	6

Notes: 1. All the cooling/heating capacities, operational noises, etc. listed below are the test results of the product upon leaving the factory;

2. All the parameters listed below are the test results under the rating operational status. In case of any changes in the parameters, please refer to the nameplate of the product for the finalized data;

3. The data for the heating capacities of the indoor units are the heat pump heating capacities, not including the auxiliary electric heating power;

4. The following performance parameters are tested and measured under the Q/GD21.10—2002 Standards.

● Parameters for Cassette Type Indoor Units

Trouble-shooting

● The Following Phenomena are not Operational Failures:

Phenomena		Cause
Air conditioning system does not work.	Activation immediately after the stop of operations	The overload protection maintains a delay of 3 minutes before re-activation.
	Upon the turning on of the power	Wait for about one minute.
Thin fog blown from the unit	During the cooling operation	The air with high humidity inside the room is cooled swiftly.
The system produces noises.	Slight tick-tack sound may be heard upon starting the operation	The sound is produced from the electronic expansion valve in the initialization process.
	There are sustained s—s—s sounds during the cooling operation	The sound is made by the refrigerant in flowing inside the unit.
	There are s—s—s sounds when activation or stopping	The sound is made when the flow of the gas form refrigerant stops.
	There are sustained s—s—s sounds during and after the operations	The sound is from the operation of the drainage system.
	There are quacking sounds during and after the operations	The sound is produced from the frictions caused by the expansion of the front panel or other parts due to temperature variations.
The air conditioning system blows out dust.	Upon activation after long time period of suspension	The dust inside the indoor units is blown out.
The air conditioner emits odor.	During operational processes	The odor inside the room is sucked in by the units and then blown out.

● After services

- ☆ In any case that the air conditioning units that you have purchased happen to have any quality problem or other troubles, please contact the local authorized Gree After Service Department. Refer to the “Directory of Nationwide Network of Gree Service Centers” for details.

The selection of installational place and notice of the air conditioner unit

● The selection of the installational place of the air conditioner unit

The installation must accord with the national and local safe criterion. Since the quality of installation would affect the operation directly, user should contact the seller and have the conditioner installed and tested by the professional install personnel according to the install instruction instead of install by his/her ownself. Only connect the power after all the installation works are finished.

● The selection of the installational place of the indoor unit

- ☆ Prevent direct sun burn.
- ☆ Make sure that the top steeve, ceiling, and the structure of the construction etc. is strong enough to bear the weight of the unit.
- ☆ The drainage pipe is easy to drain.
- ☆ The air flow is not blocked at the outlet and intake vents.
- ☆ The connecting pipe indoor and outdoor can by lead to outside conveniently.
- ☆ The unit cannot be installed in the place where stored the flammability, easy explod thing or the place where would have leakage of flammability and explod gas.
- ☆ The unit cannot be installed in the place where has the corrupt gas and serious dust, saline fog, lampblack and huge humidity.

The selection of installational place of outdoor unit

- ☆ The outdoor unit must be installed on the steady and strong bracket.
- ☆ The outdoor unit should anear to the indoor unit prosibly, to minimize the length and the bend amount of the refregerion pipe.
- ☆ Prevent to install the outdoor unit under the window or between the construction which lead the normal operating noise pass though into the room.
- ☆ The air flow is not blocked at the outlet and intake vents
- ☆ Install the unit in the place with good ventilation so that the unit could suck and discharge enough air.
- ☆ The unit cannot be installed in the place where has flammability, easy explod thing or the place with polluted air like serious dust, saline fog, etc..

The intake and outlet vent cannot install wind lead tube. When the unit is heating indoor, the condensation water would flow downward from the chassis of the outdoor unit; When the outdoor temp. is below 0°C (32°F), the condensation water would frozen. When install the outdoor unit should note not to affect the heat emit.



Note!

- The air conditioner unit installed in the following place may have malfunction, if the malfunction cannot prevent, please contact the Nominated Repair Centre Of Gree Electric Appliances, Inc. Of Zhuhai.
- ① the place with greasy all around; ② the seashore place with salinity and alkali; ③ the place with vulcanized gas(such as vulcanized hot spring); ④ the place with high frequency equipment (such as wireless equipment, electric welding machine and medical treatment equipment); ⑤ the place with special environment.

The selection of installational place and notice of the air conditioner unit

● The electric cord disposal

- ☆ The cord disposal should be installed according to the National Principal.
- ☆ The power must use the rated voltage and the electric circuit specific for air conditioner unit.
- ☆ Please don't pull the power cord vigorously.
- ☆ All the electric equipment should be installed by the professional personnel according to the local law, regulation and this instruction.
- ☆ The power cord diameter should be big enough, the destroyed power cord and connecting cord should be replaced by the specific cord.
- ☆ The earthing should reliably connect with the specific earthing equipment in the architecture, and this should be done by the professional personnel. There must be creepage protection switch and air switch with enough capacity in the rated circuit (reference the following form). The air switch should maintain the functions of magnetic de-buckle and heat de-buckle to assure the protection when circuit-short and overload happen.

Suitable Model	Air Switch Capacity	Recommended Lead wire (Section×piece)
GMV(L)-R200W2/B	30A	4. 0mm ² ×5
GMV(L)-R220W2/B	30A	4. 0mm ² ×5
GMV(L)-R260W2/B	40A	6. 0mm ² ×5
GMV(L)-R300W2/B	40A	6. 0mm ² ×5
GMV(L)-R420W3/A	60A	10. 0mm ² ×5
GMV(L)-R560W4/A	80A	10. 0mm ² ×5
GMV(L)-R620W4/A	80A	10. 0mm ² ×5

● Earthing requirement

- ☆ The air conditioner is class I appliance, so please do take the reliable measurement to earthing.
- ☆ The yellow and green cord in the air conditioner unit is earthing cord which cannot be used for other purpose, and cut off, as well as fixed up with screw. Otherwise, it would lead electric shock.

☆ The earthing resistance should fit the requirement of the national standard GB17790.

☆ The reliable earthing terminal must be offered by the user power. And please don't connect the earthing cord to the following place:

- ① Tap water pipe; ② Coal gas pipe; ③ Ejection pipe; ④ The place that is considered to be not reliable by the professional personnel.

● Noise notice

☆ Please install the air conditioner in the place with good ventilation to prevent the decrease of the operate capacity and increase of loud noise.

☆ Please install the unit firmly on the bracket that can bear the weight adequately, otherwise it would cause oscillate and noise.

☆ Make sure that the heat wind and noise would not interfere the neighbour when installing the outdoor unit.

☆ Don't pile up any obstructs near the outlet vent of the outdoor unit, otherwise, it would decrease the operate capacity and increase noise.

☆ Please contact the seller if some abnormal noise is heard from the air conditioner unit when operating.

● The attachment used for installation

Every attachment used for installation of the indoor and outdoor unit please refer to the packing list in every individual package carton.

Trouble-shooting



Warning!

- In case of any abnormal phenomena (such as unpleasant smell, etc.), stop the operation of the units immediately and turn off the main power supply. Contact the authorized Gree Service Center. If the system keeps operating when some abnormal conditions happen, damages might be caused to the air conditioning units, and such hazards like fire or electric shock accidents might occur.
- Never try to do the repairs by yourself. Erroneous maintenance or repairs will cause electric shock or fire hazard. Please contact the authorized Gree Service Center for professional maintenance and repairs.

● Follow the Checklist Before Contacting the Services of Repairs:

Phenomena	Cause	Corrective remedies
Air conditioning system does not operate at all.	Fuse blown or breaker off	Replace the fuse or turn on the breaker.
	Power failure	Reactivate the system for operations when power is restored.
	Power supply not connected	Connect the power supply.
	Poor battery power of remote controller	Replace with new batteries
	Remote controller out of control range	Practice controls within the range of 8 meters.
The system stops immediately after being activated.	The air inlet or outlet openings of the indoor or outdoor units are blocked.	Remove the obstacles.
Abnormal operations of cooling, heating	The air inlet or outlet openings of the indoor or outdoor units are blocked.	Remove the obstacles.
	Improper setting of temperature	Adjust the temperature setting on the wireless remote controller or remote controller.
	Air speed setting too low	Adjust the setting on the wireless remote controller or remote controller.
	Incorrect direction of air delivery	Adjust the setting on the wireless remote controller or remote controller.
	Doors or windows open	Close the doors and windows.
	Direct sunlight exposure	Hang a window curtain or louver.
	Too many people in the room	
	Too many heat sources in the room	Reduce the heat sources.
Filter screen blocked by dirt	Clean the screen.	

● Notes

If no cause is identified after going through the above checklist, please contact the authorized Gree Service Center, describing the symptoms and model of your air conditioning units.

Method of maintenance

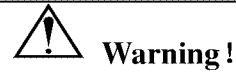

Warning!

- When cleaning the air conditioner unit, the units must be turned off, and the main power supply source to the air conditioners be disconnected. Otherwise, it might cause electric shock hazards.
- Do not get the air conditioning units wet, which might cause electric shock hazards. It must be made sure that under no circumstance should the air conditioning units be cleaned by way of flushing water.



Attention!

- Some volatile liquids like the diligent or gasoline may damage the outer appearance of the air conditioner units (Use only the soft and dry cloth or wet cloth soaked with neutral detergent solutions to clean the outer cases of the units).
- Never try to use warm water above 45°C to clean the outer case of the units, which might cause fading or deformation.
- Do not dry the air filter screen of the indoor unit on the fire, which might cause fire hazard or deformation of the screen.

● Checks to be Made Before the Starting of the Operational Seasons

- ☆ Check to see if the air inlet or outlet openings of the indoor and outdoor units are blocked;
- ☆ Check to see if the units are properly grounded;
- ☆ Check to see if the batteries of the remote controller have been replaced;
- ☆ Check to see if the air filter screen is properly placed;
- ☆ Check to see if the outdoor unit is firmly installed. Contact the authorized Glee Service Center for any abnormal phenomena.
- ☆ If the unit is to be activated for operations after long time period of suspension, the main power switch of the air conditioning system should be turned "ON" 8 hours in advance of the operation so as to activate the system successfully and smoothly.

● Maintenance After the Ending of the Operational Seasons

- ☆ Clean the filter screen and the bodies of the indoor and outdoor units;
- ☆ Disconnect the main power supply for the air conditioning system;
- ☆ Clear off the dust and foreign objects on the outdoor unit;
- ☆ In case of any rust to the outdoor unit, apply some paint on the rusted section so as to prevent the rusted area from expanding.

Please refer to the supplied operational instruction manuals of the indoor units for the details of the specific methods for the maintenance of various indoor units.

Installation of the outdoor units

● Points of Attention for the Installation of the Outdoor Units

In order to ensure the smooth operations of the units, the selection of the installation position should follow the basic principles described below:

- ☆ The installation of the outdoor units should prevent the back flow of the exhausted air from the outdoor unit, and there should be enough spaces for maintenance operations around the unit.
- ☆ The installation position must have a good ventilation condition so as to allow the unit to take in and exhaust sufficient air, which will ensure no blockage for the air inlet and outlet. Remove anything that might block the air inlet into or outlet from the unit.
- ☆ The installation position should be strong enough to bear the weight of the outdoor unit, and should have good conditions for reducing operational noises and vibration. It should be made sure that the air delivery and operational noise will not disturb the neighbors.
- ☆ Special hoisting holes must be used to lift and move the outdoor unit. Care must be taken to protect the unit during the hoisting and installing operations. It is not allowed to scrap or damage the metal parts that might cause rust.
- ☆ Direct exposure to the sunlight is to be avoided as much as possible.
- ☆ The installation position should allow the smooth discharge of rainfalls and defrosting water.
- ☆ It should be made sure that the unit will not be buried in the snow at the installation position, nor affected by dust or oil fogs.
- ☆ Rubber absorbers or spring absorbers should be used for the installation of the outdoor unit so as to meet the specifications of noise & vibration reductions.
- ☆ The installation dimensions should follow the requirements specified in the installation instruction manual. The outdoor unit must be firmly fixed at the installation position.
- ☆ The installation of the outdoor unit must be done by professional staff.

● Installation of the Outdoor Unit

1. Outer dimensions of the outdoor units

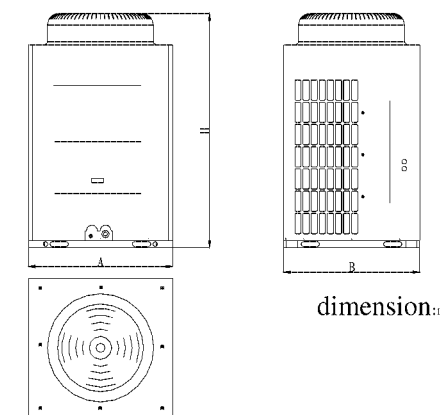

dimension:mm

model	A	B	H
GMV(L)-R200W2/B	990	840	1715
GMV(L)-R220W2/B	990	840	1715
GMV(L)-R260W2/B	990	840	1715
GMV(L)-R300W2/B	990	840	1715

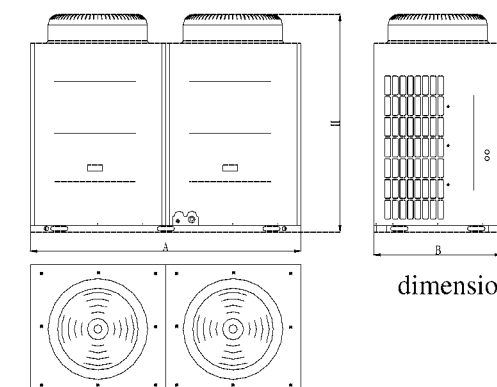

dimension:mm

model	A	B	H
GMV(L)-R420W3/A	1980	840	1695
GMV(L)-R560W4/A	1980	840	1695
GMV(L)-R620W4/A	1980	840	1695

Installation of outdoor units

2. Installation hole positions of outdoor units

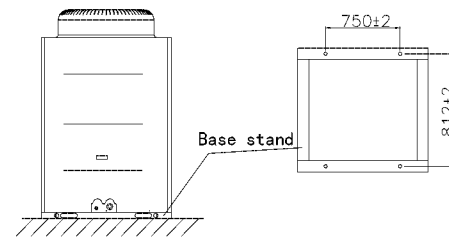

Schematic diagram for installation holes of outdoor unit

GMV(L)-R200W2/B、GMV(L)-R220W2/B、GMV(L)-R260W2/B、GMV(L)-R300W2/B, Schematic diagram for installation holes of outdoor unit

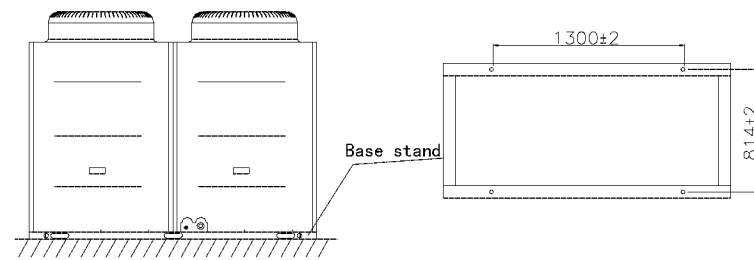

Schematic diagram for installation holes of outdoor unit

GMV(L)-R420W3/A、GMV(L)-R560W4/A、GMV(L)-R620W4/A, Schematic diagram for installation holes of outdoor unit

3. When removing the outdoor unit, two ropes are needed to hang the unit along the four ways. In order to avoid the excursion, the angle between the ropes should be less than 40°, the outdoor unit GMV-R150W/A is shown below and other outdoor units are similar to it.

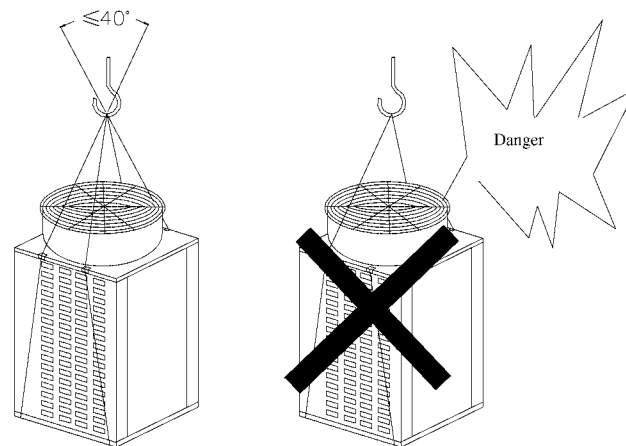

4. When installing the unit, the M12 crew is utilized to fix the supporter and base frame of the units.

Configuration of the unit and name of each part

● System configuration

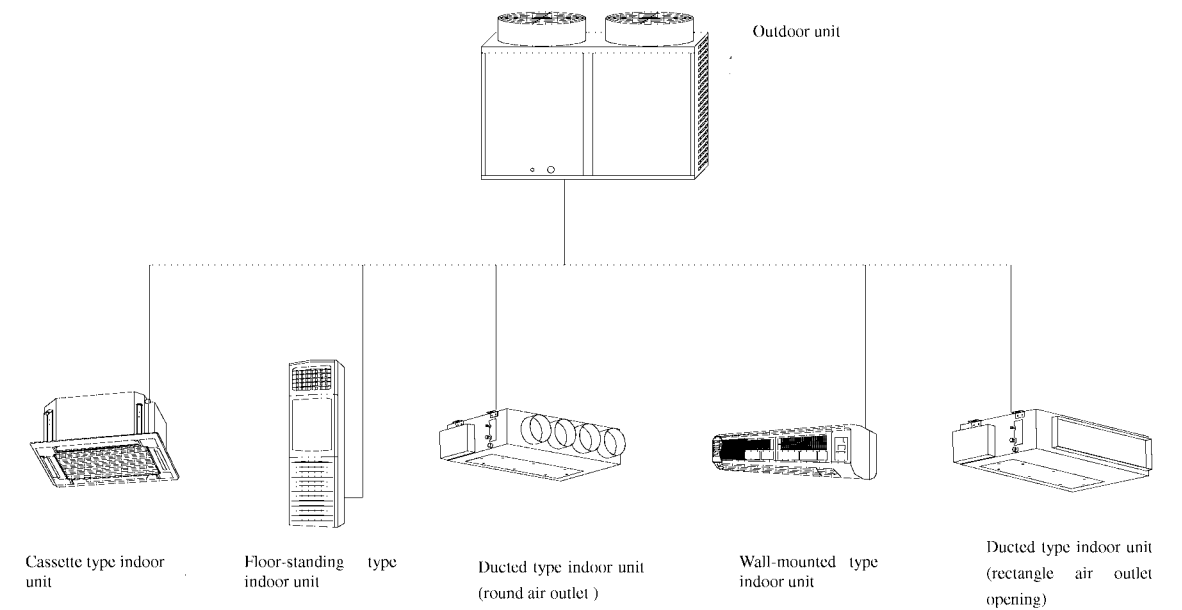

The digital multi variable air conditioning unit is composed of one outdoor unit and a maximum combination of 32 indoor units, which can be of the cassette type, wall-mounted type, ducted type, low static ultra-thin ducted type and floor-standing type. The wall-mounted type and floor-standing type indoor units are controlled by remote controller and the ducted type indoor units and low static super thin ducted type indoor units can be controlled either by wireless remote control or by remote control. The cassette type, one way air-supply cassette type indoor units can be optionally controlled either by remote control or by remote control. Once any one of the indoor units in the system receives a signal for operation, the outdoor unit will begin operating. When all the indoor units stop operation, the outdoor unit stops operation as well.

● Operational Principle for Cooling-only Type Digital Multi variable Air Conditioner Units

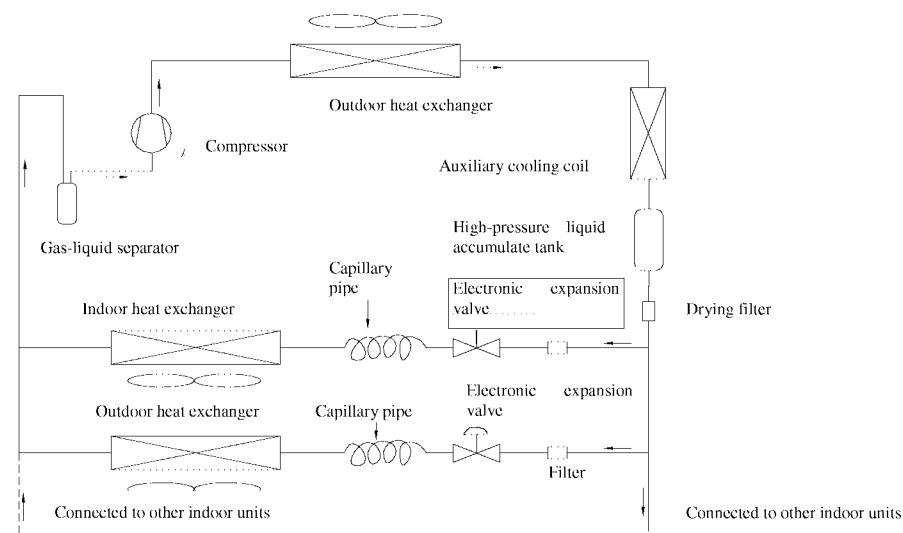

Schematic diagram for the operational principle for cooling-only type digital multi variable air conditioner units

The indoor and outdoor units will begin to operate once the power is turned on. During the cooling operation, the low-temperature and low-pressure refrigerant gases from various indoor unit heat exchangers will be gathered together and then be sucked in by the compressor to be compressed into the high-temperature and high-pressure gases, which will then be discharged into the heat exchanger of the outdoor unit where they undergo the heat exchange process with the exterior air and then become the liquid state refrigerant. Through the branching pipe or the diversity branching pipe, the liquid refrigerant flows to various indoor unit. Pressure will be reduced by way of the throttling components. After dropping of temperature, the liquid refrigerant passes into the heat exchangers of the indoor units where it undergoes the heat exchange process with the air for conditioning and then becomes the low-temperature and low-pressure refrigerant gas. Such a cycle is repeated again and again so that the cooling purpose is achieved.

The installation of outdoor unit

5. The requirement of installation space dimension for unit body as show in Fig.28.

☆ The requirement of installation space dimension for outdoor unit of GMV(L)-R420W3/A、GMV(L)-R560W4/A、GMV(L)-R620W4/A.

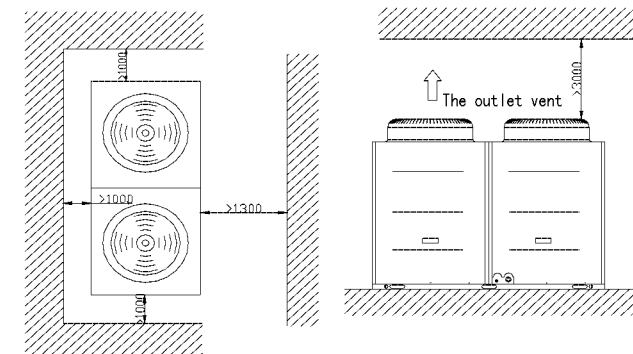

☆ The requirement of installation space dimension for outdoor unit of GMV(L)-R200W2/B、GMV(L)-R220W2/B、GMV(L)-R260W2/B、GMV(L)-R300W2/B.

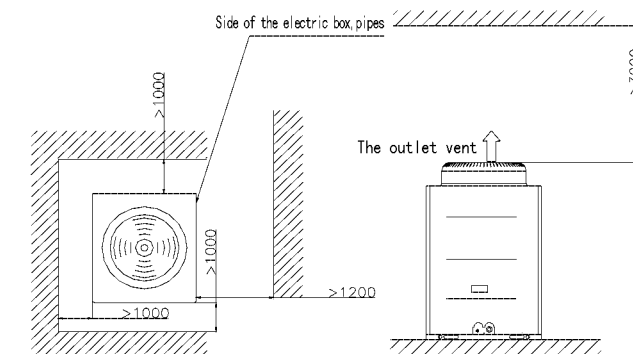

6. The outdoor unit should be installed on the 10cm or base of concrete.

● Electric wiring

⚠ ATTENTION:

☆ The outdoor unit and indoor unit should be supplied by the same power, or could be supplied separately, make sure the power supply of each indoor units should be the same..

☆ It is necessary to install the breaker which could break off the whole power system.

● The connection of power cord:

1. Put the wire through to the rubber band.
2. Connecting the power cord with the terminal marked "L1, L2, L3, N" and earthing crew.
3. Using the wire clamp to fix the wire.

● The connection of wiring(communication wire):

1. Open the electric box cover of the outdoor unit.
2. Put the wiring (communication wire) through the base frame, across the rubber band of the electric box.
3. Insert the wiring (communication wire) into the tript needle file CN46 or CN28 of the outdoor unit circuit board.
4. Use the clamp to fix the wiring (communication wire).
5. Reattach the cover of the terminal board then tighten the crews.
6. Reattach the front panel.

The installation of outdoor unit

● The Manifold Method of Connection Pipe

The manifold methods of indoor unit and outdoor unit is shown as following:

The pipeline manifold (is shown below)

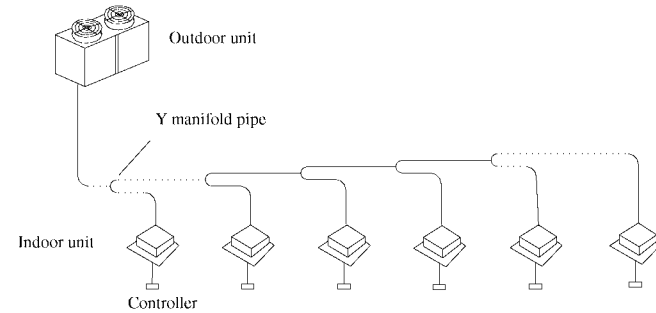

Operational theories for the air conditioning units

● Operational Principle for Heat Pump Type Digital Multiple Connection Air Conditioners

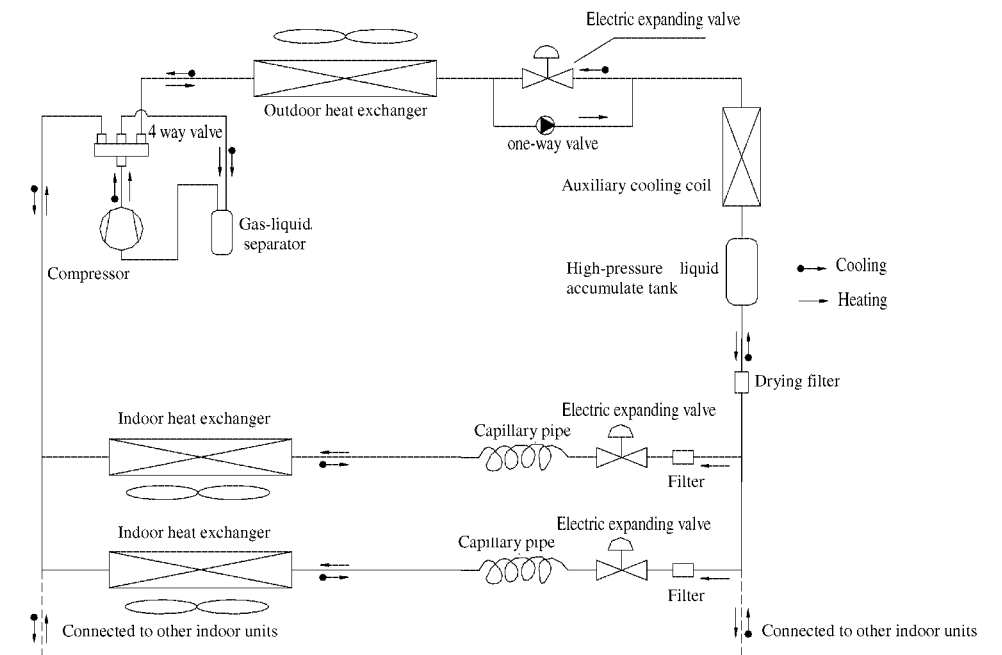

Schematic diagram for the operational theories for heat pump type digital multi variable air conditioner units

The indoor and outdoor units will begin to operate once the power is turned on. During the cooling operation, the low-temperature and low-pressure refrigerant gases from various indoor unit heat exchangers will be gathered together and then be sucked in by the compressor to be compressed into the high-temperature and high-pressure gases, which will then be discharged into the heat exchanger of the outdoor unit where they undergo the heat exchange process with the exterior air and then become the liquid state refrigerant. Through the Y manifold pipe or the manifold gathering pipe, the liquid refrigerant flows to various indoor unit. Pressure will be reduced by way of the throttling components. After dropping of temperature, the liquid refrigerant passes into the heat exchangers of the indoor units where it undergoes the heat exchange process with the air for conditioning and then becomes the low-temperature and low-pressure refrigerant gas. Such a cycle is repeated again and again so that the cooling purpose is achieved. During the heating operation, the 4-way electromagnet valve operates in the reverse direction so that the refrigerant will undergo the cycling in the reverse direction of the cooling process. The refrigerant discharges heat in the heat exchangers of the indoor units (the electric heating components also begin to operate under a certain condition to produce heat), and undergo the heat pump heating cycles by absorbing heat in the heat exchanger of the outdoor unit so that the heating purpose is achieved.

Filling of refrigerant and test running

● Post-installation Checklist

Item for check	Possible occurrences in case of improper installation	Checking
Are all the parts of the unit firmly installed?	The unit might fall down, vibrate or produce much operational noises	
Has the check for air leakage been done?	Air leakage might lead to insufficient cooling (heating) capacity	
Is there enough thermal insulation for the unit?	There might be dew condensation or water dripping.	
Is the drainage system smooth and unblocked?	There might be dew condensation or water dripping.	
Is the voltage of the power supply the same as the specifications on the product nameplate?	Incorrect voltage might lead to operational failures or damages of machine parts.	
Is the wiring and installation of pipelines correct?	Incorrect voltage might lead to operational failures or damages of machine parts.	
Is the unit properly grounded?	Improper grounding might result in hazard of electric power leakage	
Do the types and specifications of the electric cables meet the requirements?	Improper types or specifications might lead to operational failures or damages of machine parts.	
Is there anything blocking the air outlet or air inlet for the indoor and outdoor units?	Blockage might result in insufficient cooling (heating) capacity.	
Have the lengths of the refrigerant pipe and the volume of refrigerant filling been recorded?	Without the record, it will be hard to control the volumes of the additional filling of refrigerant.	

● Trial Running

1. Checks to be done prior to the test running

- ☆ Check to see if there are any damages on the outer appearance and pipeline system of the unit caused during the shipping or delivery;
- ☆ Check to see if the wiring terminals of the electric components inside the unit are loose or off, and if the sequence of phases is correct;
- ☆ Check to see if the turning direction of the fan is correct;
- ☆ Check to see if all the valves in the system are completely open;

2. Trial running

- ☆ The test running must be done by the professionals under the circumstance that all the items in the above checklist are in the qualified conditions;
- ☆ Supply power to the unit and set the remote controller or the remote controller in the “ON” mode;
- ☆ Within one minute, the fan of the outdoor unit and the compressor will be automatically activated;
- ☆ After the compressor is activated, the test running should be stopped immediately for further checks in the case that there occur some abnormal sounds.

The connection of the indoor unit and outdoor unit

● Capacity codes of indoor unit and outdoor unit

	Capacity type	Capacity code	Capacity type	Capacity code
Indoor unit	20 Model	20	50 Model	50
	25 Model	25	60 Model	60
	30 Model	30	70 Model	70
	35 Model	35	80 Model	80
	40 Model	40	100 Model	100
	45 Model	45	120 Model	120
Outdoor unit	200 Model	200	400 Model	400
	250 Model	250	500 Model	500
	300 Model	300	600 Model	600

☆ One outdoor unit can match with at least thirty-two outdoor unit;

☆ The summation of indoor unit capacity code could be selected in the range of the value of outdoor unit capacity code from 50%-135%.

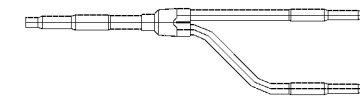

Y manifold pipe

The type Y manifold pipe and manifold pipe could be selected from the following form:

	The total capacity of the indoor unit which is behind the manifold	Model
Y manifold pipe	≤ 150	FQ01
	150~300	FQ02
	>300	FQ03

● The permitted length and height difference of connection pipe

		Permitted value	Total length of tubing
The total length of tubing (actual length)		250m	$L_1+L_2+L_3+L_4+L_5+L_6+L_7+a+b+\dots+i+j$
The length of the farthest tubing (m)	Actual length	100m	$L_1+L_3+L_4+L_5+L_6+j$
	Approximate length	125m	
The approximate length which is from the first manifold to the farthest tubing L (m)		50m	$L_3+L_4+L_5+L_6+j$
The height difference of indoor unit and outdoor unit	The outdoor unit is above	50m	—
	The outdoor unit is down	40m	—
The height difference of indoor unit and outdoor unit		15m	—

The connection of the indoor unit and outdoor unit

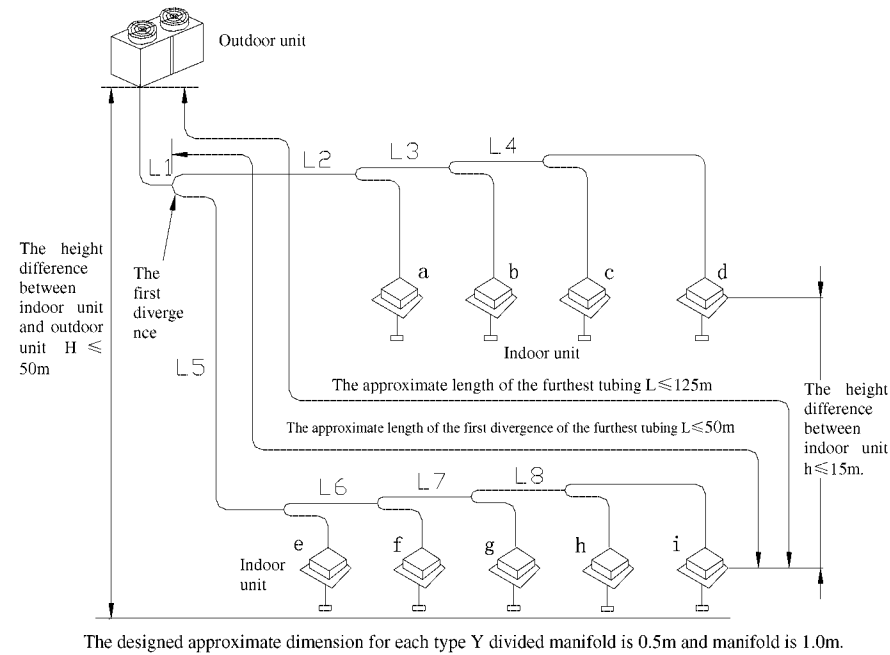

Fig.29 The permitted length and height difference

The dimensions of connection pipe

1. The dimensions from outdoor unit to the first divergence of the tubing (main tube) are same with the tubing dimensions of outdoor unit (See table 2)

Table 2: The tubing dimensions of the outdoor unit

Item	Model		GMV(L)-R200W2/B	GMV(L)-R220W2/B	GMV(L)-R260W2/B	GMV(L)-R300W2/B	GMV(L)-R420W3/A	GMV(L)-R560W4/A	GMV(L)-R620W4/A
	Connection pipe	Gas pipe	mm	φ 25.4	φ 25.4	φ 28.6	φ 28.6	φ 34.8	φ 41.3
Liquid pipe		mm	φ 12.7	φ 12.7	φ 12.7	φ 12.7	φ 16.3	φ 19.05	φ 19.05
Method of connection			Brazing						

2. The tubing dimensions of the divergent part (manifold dimension) are selected according to the capacity of the indoor unit that is behind the manifold. If they are more than the outdoor unit capacity, please refer to the outdoor unit capacity.

Table 3: Dimensions of manifold

Unit: mm

The summation of indoor capacity	Gas pipe	Liquid pipe
Less than 80	φ 15.9	φ 9.52
80~140	φ 19.05	φ 12.7
140~180	φ 22.2	φ 12.7
180~220	φ 25.4	φ 12.7
220~300	φ 28.6	φ 12.7
300~380	φ 31.8	φ 15.9
380~450	φ 34.9	φ 15.9
450~520	φ 38.1	φ 19.05
More than 520	φ 41.3	φ 19.05

Filling of refrigerant and trial running

Filling of Refrigerant

1. Refrigerant has been filled when the indoor unit leaves the factory. Additional filling for refrigerant should be made on the installation spot for the part of the connected pipelines.
2. Check and see if the liquid valve and air valve of the outdoor unit are closed.
3. Use a vacuum pump to expel the air inside the indoor unit and the connecting pipes at the valve of the outdoor unit as shown in Fig.33.

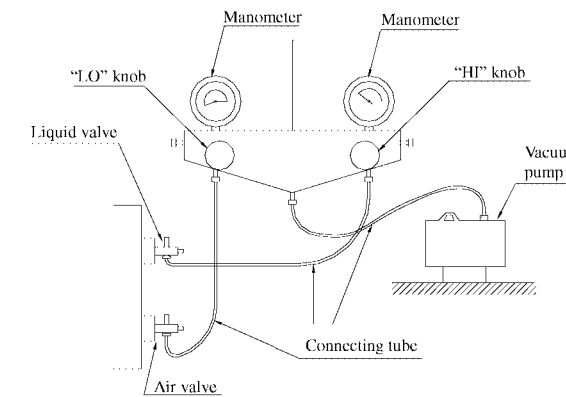

Fig.33

4. Make sure there is no leakage in the system, when the compressor is not working, fill the specified additional R22 refrigerant into the unit at the filling opening of the liquid pipe valve of the outdoor unit (it is not allowed to do the filling on the side of the air pipe).

Method of Calculating the Mass of the Additional Filling of Refrigerant

1. The mass of refrigerant in the system when the outdoor unit leaves the factory

	GMV(L)-R200W2/B	GMV(L)-R220W2/B	GMV(L)-R260W2/B	GMV(L)-R300W2/B	GMV(L)-R420W3/A	GMV(L)-R560W4/A	GMV(L)-R620W4/A
Filling(kg)	14	14	16	16	35	40	40

Notes: ☆ The mass of the refrigerant filled upon leaving the factory does not include the needed amount of the additional filling of refrigerant for the pipeline system connecting the indoor and outdoor units;

☆ The length of the connecting pipes is determined on the installation site. And the needed amount of the additional filling of refrigerant is to be determined by the dimensions and lengths of the liquid pipes.

2. Calculation method for the mass of the additional filling of refrigerant (with the liquid pipe length as the basic reference)

Volume of additional filling of refrigerant = Σ length of liquid pipe \times additional filling amount per meter of liquid pipe

Additional filling amount per meter of liquid pipe (kg/m)					
φ 22.2	φ 19.05	φ 15.9	φ 12.7	φ 9.52	φ 6.35
0.41	0.29	0.187	0.12	0.06	0.03

The instruction of code switch

● The Instruction of Code Switch

- ☆ The addresses of the indoor units are allotted on the basis of the air conditioning system programming. The addresses for the indoor units in the same system should not be repeatedly used.
- ☆ The address and capacity of an indoor unit is allotted by way of the 8-bit DIP switch 1 on the main board of the indoor unit. The 5th to 8th bits for the setting of the capacity of the indoor unit have been preset before the indoor unit leaves the factory. During installation, only the 1st to 4th bits are to be adjusted for the allotment of the address of the indoor unit.
- ☆ The address of the wired control is allotted by way of the 4-bit DIP switch on the main board of the remote controller. The address of the wired control should be identical to that of the indoor unit.
- ☆ For the floor-standing type indoor units and Model 25, 35 and 50 wall-mounted type indoor units, the address and capacity of an indoor unit is allotted by way of two 4-bit DIP switches on the main board of the indoor unit, in which the 4-bit DIP switch for the setting of the capacity of the indoor unit (with the mark of “capacity” underneath) has been preset before the indoor unit leaves the factory. Before installation, only the other 4-bit DIP switch (with the mark of “address” underneath) is to be adjusted for the allotment of the address of the indoor unit.

The setting of the address for the indoor unit and for the remote controller is indicated in the following form:

1~4 bit address									
8 (4) bit the corresponding pin on the DIP switch									
4	3	2	1	Address	4	3	2	1	Address
0	0	0	0	1	1	0	0	0	9
0	0	0	1	2	1	0	0	1	10
0	0	1	0	3	1	0	1	0	11
0	0	1	1	4	1	0	1	1	12
0	1	0	0	5	1	1	0	0	13
0	1	0	1	6	1	1	0	1	14
0	1	1	0	7	1	1	1	0	15
0	1	1	1	8	1	1	1	1	16

Note: adjust to ON for “0”

a) Instructions for code switch of outdoor unit

- ☆ There is only one main board in the outdoor unit that capacity is 420 below, it is unnecessary to adjust the code switch.
- ☆ There are two pieces of main board in the outdoor unit that capacity is 420 or above (please refers to above diagram), thereinto, the 4-bit code switch S2 of the slave main board should be adjusted to “0000”, the code switch should be adjusted to “ON” for 0.

The connection of indoor unit and outdoor unit

3. The dimension (indoor tubing) that is from the divergent part to the indoor unit tubing (indoor tubing) is the same with the dimension of indoor unit tubing, (See table 4) (If the dimension from first divergence to a indoor unit is more than 30m, so will increase one dimension from the first divergence to the gas side tubing of indoor unit).

Table 4: Dimensions of indoor tubing

Unit: Inch

Models of indoor units	Gas pipe	Liquid pipe
Model 20、 25	φ 9.52	φ 6.35
Model 30、 35	φ 12.7	φ 6.35
Model 40、 45、 50	φ 12.7	φ 9.52
Model 60、 70、 80	φ 15.9	φ 9.52
Model 100、 120	φ 19.05	φ 12.7

● The pipe connection of indoor unit and outdoor unit

- ☆ Screw nut with torque please refer to table 1.
- ☆ The copper flare should be aimed at the corrugated connect joint, screw the flare nut tightly with hands.
- ☆ Screw down the flare nut with torque wrench, until there is the sound like “ka ka……”
- ☆ The bending of the tubing should not too small, otherwise it will broken. Please use the bender when installation personel bending the tubing.
- ☆ Using the sponge to wrap the unheat-preserved connection pipe and joint , using the plastic bag to pack them up.

⚠ ATTENTION:

1. When connecting the indoor unit with connection pipe, please do not to pull all the joints of indoor unit, otherwise it may cause the damage of capillaries and other tubes or it may cause leakage.
2. Connection pipe should be supported by the holder, can not supported by the units.

● The connection of manifold

1. Y manifold pipe

- ☆ The Y manifold pipe has additional tubes, they are used to adjust the diameter of different tubes, if the dimension of spot use tube is different from the dimension of manifold joint, using the casing knife to cut from the middle of it and deburring. As shown below:

The connection of indoor unit and outdoor unit

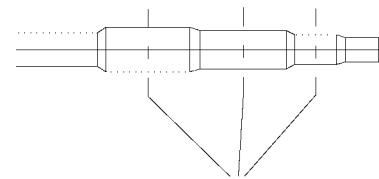

Cut from the middle of it

- ☆ When installing the Y manifold pipe, make the manifold vertically or horizontally.

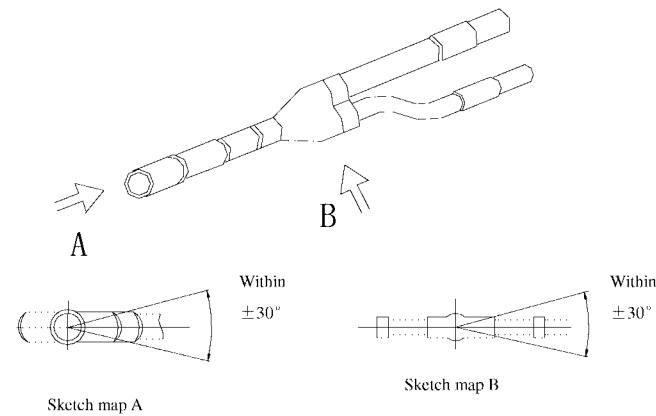

- ☆ For the gas pipe side, adopts the heat insulation material that can stand 120°C or much more higher temperature, can not use the enclosed foam for heat preservation. For liquid pipe is for water dripping.

Instructions for code switch

● Instructions for code switch of indoor unit

- ☆ The capacity is below 420 of outdoor unit should be in accordance with the planning of air conditioner system to assign indoor units' address, the connected addressess of indoor units for the same outdoor unit cannot repeat.
- ☆ The capacity is 420 or above of outdoor unit should be in accordance with the planning of air conditioner system to assign the indoor units address, for a same outdoor unit, according to the requirement, to connect 1~4 pieces of commutator, when the connected quantity of indoor units is 1~16 sets, for a outdoor unit, one commutator could be connected; when the connected quantity of indoor units is 17~32 sets, two commutators could be connected; when the connected quantity of indoor units is 33~48 sets, 3 commutators could be connected; the connected quantity of indoor units is 49~64 sets, 4 commutators could be connected. Under the same commutator, it could be connected 16sets of indoor unit at most, the address 1~16 of indoor unit should not repeat; under the different commutator, the address of indoor unit could be the same. As show in below:

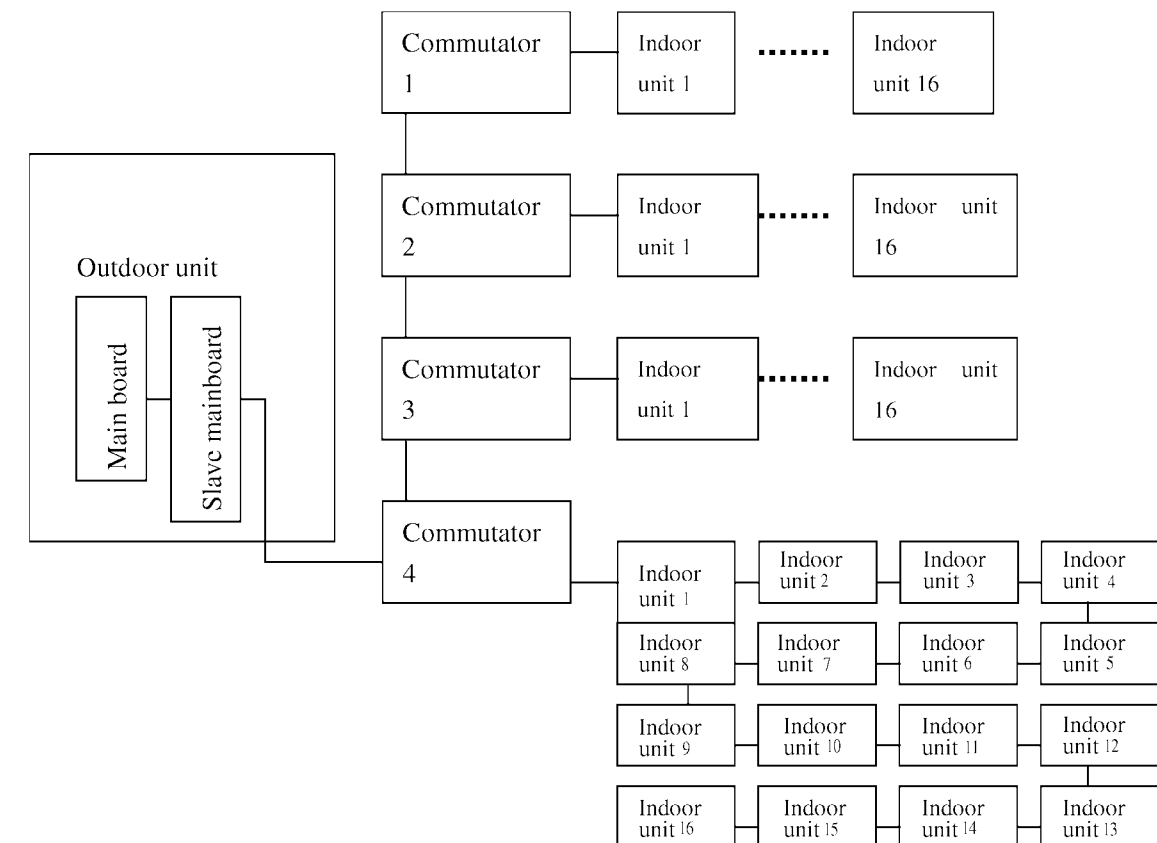

The installation of commutator

● Electric wiring

⚠ NOTE: The power supply of commutator should be in accordance with the power supply of indoor unit.

1、 The connection of power cable:

Connect power cable to the same power supply socket of indoor unit.

2、 Connection of wiring (communication):

1)、 To insert 2-core and three pin of wiring (communication) that is connected with the indoor unit into the three pin socket of the commutator.

2)、 To insert 2-core and four pin of wiring (communication) that is connected with the outdoor unit into the four pin socket of the commutator.

● Sketch map for commutator connection

The connection methods as show in below:

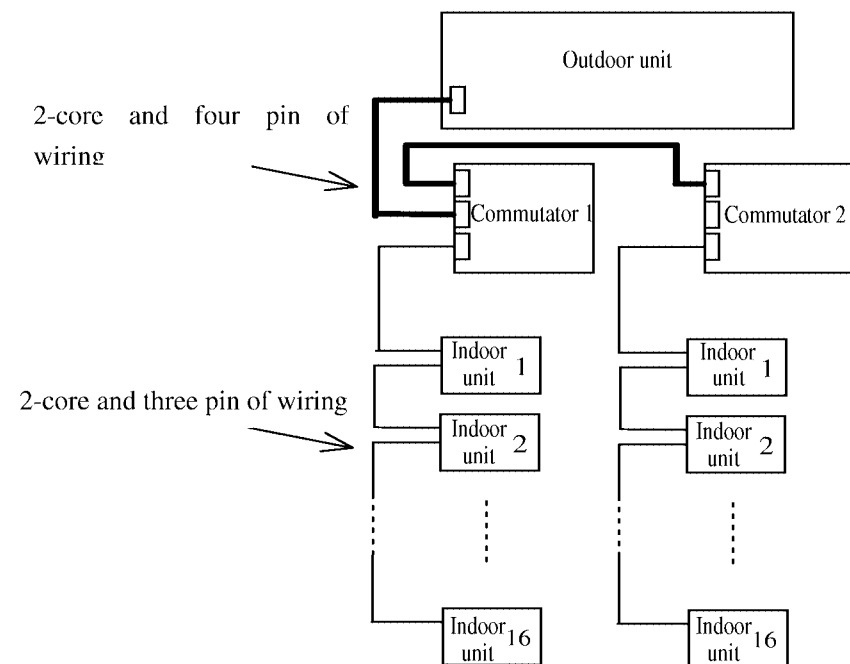

The sketch map for outdoor unit, indoor unit and commutator connection

● Methods for address code switch

There is a three-bit code switch behind the commutator. If the commutator, which is adopted in a suit of unit, is more than one set, so that needs to use the code switch for distinguish. Please refers to the follow for references:

3-bit	2-bit	1-bit	For address
0	0	0	1
0	0	1	2
0	1	0	3
0	1	1	4

Note: When code switch be adjusted to "ON" for "0".

The connection of indoor unit and outdoor unit

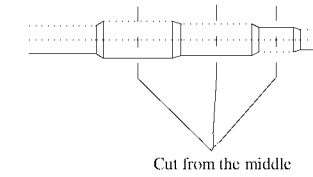

⚠ CAUTION

● In order to avoid the wrong connection, for the multi variable series air conditioner, each tube should be stuck on the tag, make sure the tube belong to which system very clearly.

● Make sure there is at least 300mm ascending pipe in the inlet side of manifold.

● The installation of connection pipe protective layer

1. In order to avoid the condensing and water dripping on the connection pipe, the gas and liquid pipe of the connection pipe should be wrapped by the insulated materials and plastic belt, isolate from the air.

2. The joint of indoor unit and outdoor unit be wrapped by the insulated material, there is no gap between the surface of the indoor unit and outdoor unit, please refer to Fig.31

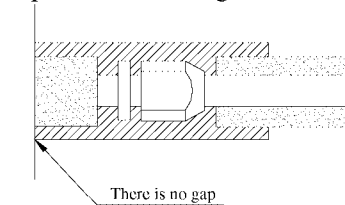

Fig.31

⚠ ATTENTION:

After wrapping, do not twist too tightly, or it will break.

3. Wrapping the tube with belt:

☆ Bundling the connection pipe and cable with belt, in order to prevent the condensing water overflow, the drainage pipe and cable should be divided.

☆ When wrapping the insulated plastic belt, each circle should fold over the half of the previous circle.

☆ After bundling, use the pipe clamp to fix them on the wall.

⚠ ATTENTION:

☆ Do not wrape them tightly, because it will reduce the insulative efficiency, make sure the condensing water is drained has been divided.

☆ After protectng and wrapping, block the wall by the sealing material.

● The communication wires connection of indoor unit and outdoor unit

Open the electric box cover of indoor unit and outdoor unit respectively; the wiring (communication wire) goes through the hole enter into the electric box. It must accord to the circuit diagram of the units, connect the indoor unit and outdoor unit (Please refer to the wiring part of the outdoor unit and indoor unit), the selection of power cord specification should refer to the power capacity, installation environment. When all of above are finished, then use the wire clamp to fix the wires, reattach the cover of electric box. The magnetic ring should be installed in both sides of the communication wire.

The connection of indoor unit and outdoor unit

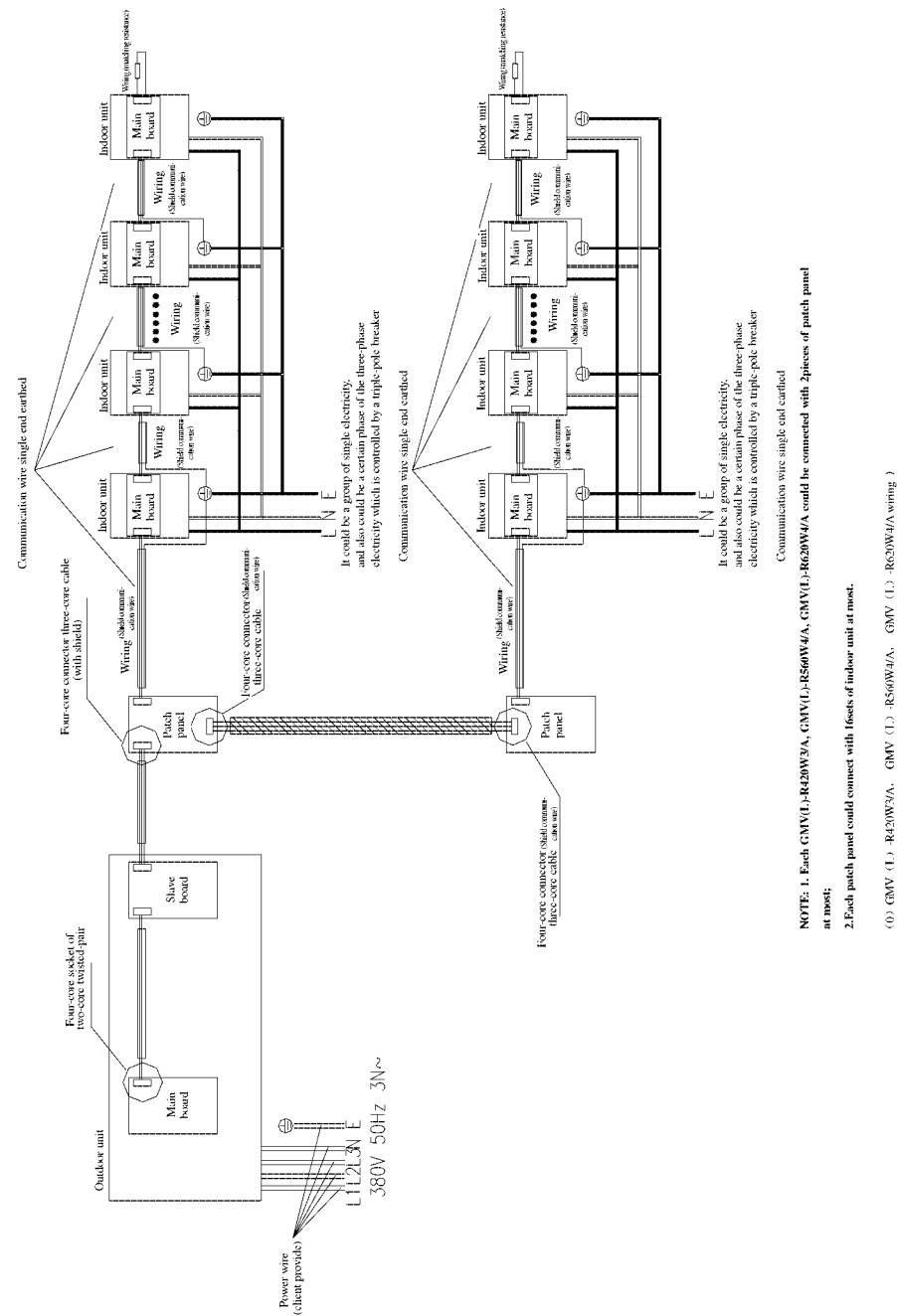

Please refer to the Fig.32 to connect the communication wires of indoor unit and outdoor unit

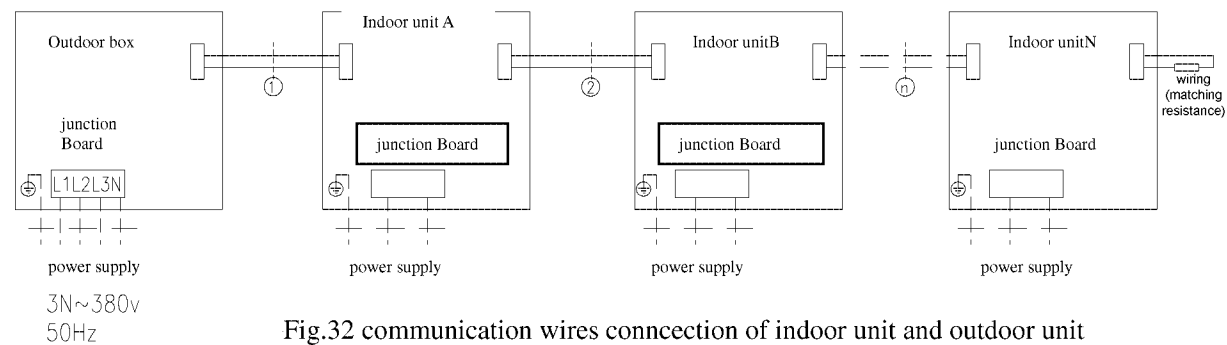

Fig.32 communication wires connection of indoor unit and outdoor unit

- Remark: 1、 The additionally installed communication wire of the last indoor unit is wiring(the resistance should be suitable)
 2、 If the indoor unit is the wall mounted type, the input and output communication wires should be attach to the indoor unit.

Installation for commutator

The commutator is used for data-exchange and data-disposal between the outdoor units and indoor units of the variable air conditioning unit. The models: GMV(L)-R420W3/A 、 GMV(L)-R560W4/A 、 GMV(L)-R620W4/A they need to be installed the commutator, if not, that the unit couldn't work normally.

When a suit of outdoor unit be connected with 16sets or less than 16sets of indoor unit, only one commutator be connected; when a suit of outdoor unit be connected with the indoor units that is more than 16 sets and less than 32 sets, two sets of commutator must be adopted, one commutator could be connected with a maximum combination of 16 sets of indoor unit. By the use of code switch that behinds the commutator to distinguish the commutator.

●The selection of installation position

- 1、 The commutator should be installed in the room;
- 2、 It should avoid the strong sun shine and rain drips, do not avoid to install in the room where there is a lot of humidity;
- 3、 There should be no big power supply, electric appliances, launcher at nearby, and should avoid the interference source;
- 4、 Do not install it to the places where are corrosive gas and serious dust, salt mist, smokes as well as the place where is damp.

●Requirements for installation

- 1、 The outline dimension of commutator and interface

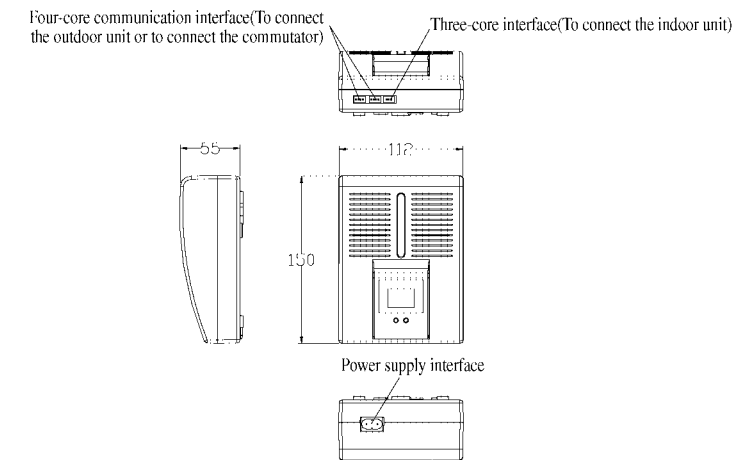

- 2、 The installation hole site for commutator

