



Service Manual

Commercial Air Conditioners

CASSETTE TYP FAN COIL UNIT





Contents

I PRODUCT	1
1. MODELS LIST	2
2. NOMENCLATURE OF THE UNIT	3
3. FUNCTION	4
4. PRODUCT DATA	4
II CONTROL	15
1. WIRELESS REMOTE CONTROLLER	16
1.1 YB1FA(X-FAN)	16
1.1.1 Operation of wireless remote control	18
1.1.2 Changing batteries and notices.	19
2. WIRED REMOTE CONTROLLER	20
2.1 Introduction to Z4E351B (optional)	20
2.1.1 Symbols on the LCD	20
2.1.2 Introduction to the Functions of the Press Keys	22
III UNIT INSTALLATION	24
1. SELECTION THE MOUNTING POSITION	25
2. DRAINAGE PIPE	26
3. PRECAUTIONS FOR DRAINAGE RAISING PIPE	27
3.1 Instruction	27
4. ELECTRIC WIRING	29
4.1 Wiring of unit and the controller	29
4.1.1 Wiring of the unit	29
5. INSTALLATION OF PANEL	31
5.1 Precautions	32
5.2 After fixing be sure no gap left between the ceiling and the panel	32
IV Unit MAINTENANCE	33
1.TROUBLESHOOTING	34
2.CARE AND MAINTENANCE	34
3. WIRING DIAGRAM	37
4. DISASSEMBLY AND ASSEMBLY PROCEDURE OF MAIN PARTS	39
5. EXPLODED VIEWS AND SPARE PART LISTS	42

I PRODUCT

1. MODELS LIST

Model Name	Product Code	Cooling/Heating Capacity (W)	Air flow Volume (m ³ /h)	Power Supply (V, Ph, Hz)	Remarks
FP-51XD/A-K	EM520N1170	2750/3400	510	220-240V~ 50Hz	
FP-68XD/A-K	EM520N1160	3300/3800	660		
FP-85XD/B-T	EM520N0930	4150/5600	800	220-240V~ 50Hz	
	EM520N0940	4160/7800	780	208-230V~ 60Hz	
FP-102XD/B-T	EM520N0910	500/6500	1020	220-240V~ 50Hz	
	EM520N0920	540/9000	1020	208-230V~ 60Hz	
FP-125XD/B-T	EM520N0890	6000/7800	1180	220-240V~ 50Hz	
	EM520N0900	6300/10000	1130	208-230V~ 60Hz	
FP-140XD/B-T	EM520N0870	8000/9000	1400	220-240V~ 50Hz	
	EM520N0880	8000/12000	1350	208-230V~ 60Hz	
FP-160XD/B-T	EM520N0850	8700/10000	1550	220-240V~ 50Hz	
	EM520N0860	9000/14000	1550	208-230V~ 60Hz	
FP-180XD/B-T	EM520N0830	9500/11000	1800	220-240V~ 50Hz	
	EM520N0840	10000/16000	1800	208-230V~ 60Hz	
FP-200XD/B-T	EM520N0810	13000/14600	2000	220-240V~ 50Hz	
	EM520N0820	13000/19000	2000	208-230V~ 60Hz	
FP-200XD/D-K	EM520N1210	12000/14200	2000	220-240V~ 50Hz	
FP-68XDT/B-K	EM520N0990	3500/6000	680	220-240V~ 50Hz	
FP-85XDT/B-K	EM520N0960	4100/6800	850	220-240V~ 50Hz	
FP-125XDT/B-K	EM520N0970	6000/9500	1250	220-240V~ 50Hz	
FP-180XDT/B-K	EM520N0980	8000/13000	1800	220-240V~ 50Hz	
FP-85XD/B-T(E)	EM520N1300	4500/5400	800	220-240V~ 50Hz	
FP-102XD/B-T(E)	EM520N1310	5000/6100	940	220-240V~ 50Hz	

PRODUCT

Model Name	Product Code	Cooling/Heating Capacity (W)	Air flow Volume (m ³ /h)	Power Supply (V, Ph, Hz)	Remarks
FP-125XD/B-T(E)	EM520N1320	6000/6900	1090	220-240V~ 50Hz	
FP-140XD/B-T(E)	EM520N1330	7400/8400	1400	220-240V~ 50Hz	
FP-160XD/B-T(E)	EM520N1340	8400/9000	1500	220-240V~ 50Hz	
FP-180XD/B-T(E)	EM520N1350	9500/10500	1640	220-240V~ 50Hz	
FP-200XD/D-K(E)	EM520N1360	11100/11700	1700	220-240V~ 50Hz	
FP-68XDT/B-K(E)	EM520N1260	3500/5800	680	220-240V~ 50Hz	
FP-85XDT/B-K(E)	EM520N1270	4500/6800	850	220-240V~ 50Hz	
FP-125XDT/B-K(E)	EM520N1280	6000/9200	1250	220-240V~ 50Hz	
FP-180XDT/B-K(E)	EM520N1290	8000/12000	1700	220-240V~ 50Hz	

2. NOMENCLATURE OF THE UNIT

FP	-	□	□	□	/	□	-	□	(E)
1		2	3	4		5		6	7

NO.	Description	Options
1	Fan coil	Fan coil unit
2	Air flow volume	Number×10m ³ /h(FP-51XD-E;FP-68XD-E)
3	Structure type	XD-Cassette Type
4	Pipes type	Default- 2 pipes; T-4 pipes
5	Design Sequence	Arranged by A, B,C...
6	Power code	E-220-240V~ 50Hz;T-220-240V~ 50Hz, 208-230V~ 60Hz; K-220-240V~ 50Hz
7	Sales territory	(E) Models applicable to EU

3. FUNCTION

- (1) Novel pattern: the exposed skin plates of unit looks so elegant and luxurious that they can be taken as the indoor decorations.
- (2) Compact design: A large number of non-metallic materials have been used, so that the body of the unit is quite light-weight and thin, which makes the unit looks sensuous.
- (3) Low noise: Dynamic principles have been adopted for the design of the fan blades so as to make sure the air volume is enough and running noise is considerably low.
- (4) Durable filter screen: The durable filter screen shares a cleaning cycle 20 times longer than that of the conventional filter screen, needless to clean it frequently.
- (5) Microcomputer control: The unit is able to automatically adjust the fan speed in accordance with the indoor ambient temperature to meet a wide range of users' requirements.
- (6) Small height of the unit, saving much installation space
- (7) Large cooling (heating) capacity, low noise, three-speed motor which can adjust the air volume and meet a wide range of users' requirements.
- (8) Excellent material, stringent process control, which guarantee the hi-quality and long life of the unit.
- (9) Die-formed drain pan, entirely bonded insulating material, carefree about the condensate water.

4. PRODUCT DATA

Model			FP-85XD/B-T	FP-85XD/B-T	FP-102XD/B-T	FP-102XD/B-T
Code			EM520N0940	EM520N0930	EM520N0920	EM520N0910
Power system	Type	V-Ph-Hz	208-230V~ 60Hz	220-240V~ 50Hz	208-230V~ 60Hz	220-240V~ 50Hz
	Input	W	70	75	130	110
Air flow volume	High	CFM	459	471	600	600
		m ³ /h	780	800	1020	1020
	Medium	CFM	371	382	599	599
		m ³ /h	630	650	950	950
	Low	CFM	324	324	529	529
		m ³ /h	550	550	900	900
Capacity	Cooling	W	4600	4500	5400	5000
	Heating	W	7800	5600	9000	6500
Electric heater rated power		W	-	-	-	-
Water system	Cooling water flow volume	l/s	0.22	0.21	0.26	0.24
	Heating water flow volume	l/s	0.22	0.13	0.26	0.17
	Cooling pressure drop	kPa	27	24	48	36
	Heating pressure drop	kPa	24	8	47	13
Sound pressure level		dB(A)	39	39	49	49

PRODUCT

Coil	Type	-	Aluminum fin-copper tube	Aluminum fin-copper tube	Aluminum fin-copper tube	Aluminum fin-copper tube	
	Operating pressure	MPa	≤1.6MPa	≤1.6MPa	≤1.6MPa	≤1.6MPa	
Motor	Type	-	FN35D-2	FN35D-2	FN35D-2	FN35D-2	
	Capacitor	μF	2	2	3.5	3.5	
Connection pipe size	Water inlet & outlet	inch	G3/4	G3/4	G3/4	G3/4	
	Condensing water drain	mm	25	25	25	25	
Outline dimension (WxDxH)	Body	mm	840×840×190	840×840×190	840×840×190	840×840×190	
	Panel TB03	mm	950×950×85	950×950×85	950×950×85	950×950×85	
Package dimension (WxDxH)	Body	mm	963×963×272	963×963×272	963×963×272	963×963×272	
	Panel TB03	mm	1033×1038×133	1033×1038×133	1033×1038×133	1033×1038×133	
Net weight	Body	kg	25.0	25.0	25.0	25.0	
	Panel TB03	kg	7	7	7	7	
Gross weight	Body	kg	33.0	33.0	33.0	33.0	
	Panel TB03	kg	11	11	11	11	
	20'GP (with panel TB03)			56	56	56	56
	40'GP (with panel TB03)			131	131	131	131
	40'HQ (with panel TB03)			147	147	147	147
Wired remote controller			Z4E351B	Z4E351B	Z4E351B	Z4E351B	
Wireless remote controller			YB1FA(X-FAN)	YB1FA(X-FAN)	YB1FA(X-FAN)	YB1FA(X-FAN)	

Model			FP-125XD/B-T	FP-125XD/B-T	FP-140XD/B-T	FP-140XD/B-T
Code			EM520N0900	EM520N0890	EM520N0880	EM520N0870
Power system	Type	V-Ph-Hz	208-230V~ 60Hz	220-240V~ 50Hz	208-230V~ 60Hz	220-240V~ 50Hz
	Input	W	130	82	140	143
Air flow volume	High	CFM	665	694	794	824
		m ³ /h	1130	1180	1350	1400
	Medium	CFM	529	588	647	735
		m ³ /h	900	1000	1100	1250
	Low	CFM	441	529	588	676
		m ³ /h	750	900	1000	1150
Capacity	Cooling	W	6300	6000	8000	8000
	Heating	W	10000	7800	12000	9000
Electric heater rated power		W	-	-	-	-
Water system	Cooling water flow volume	l/s	0.3	0.29	0.38	0.38
	Heating water flow volume	l/s	0.3	0.18	0.38	0.21
	Cooling pressure drop	kPa	27	24	33	30

PRODUCT

	Heating pressure drop	kPa	28	9	29	10	
Sound pressure level		dB(A)	43	43	48	50	
Coil	Type	-	Aluminum	Aluminum	Aluminum	Aluminum	
	Operating pressure	MPa	≤1.6MPa	≤1.6MPa	≤1.6MPa	≤1.6MPa	
Motor	Type	-	FN35B-1	FN35B-1	FN35C	FN35C	
	Capacitor	μF	2.00	2.00	4.00	4.00	
Connection pipe size	Water inlet & outlet	inch	G3/4	G3/4	G3/4	G3/4	
	Condensing water drain	mm	25	25	25	25	
Outline dimension (WxDxH)	Body	mm	840×840×240	840×840×240	840×840×240	840×840×240	
	Panel TB03	mm	950×950×85	950×950×85	950×950×85	950×950×85	
Package dimension (WxDxH)	Body	mm	963×963×325	963×963×325	963×963×325	963×963×325	
	Panel TB03	mm	1033×1038×133	1033×1038×133	1033×1038×133	1033×1038×133	
Net weight	Body	kg	27.0	27.0	27.0	27.0	
	Panel TB03	kg	7	7	7	7	
Gross weight	Body	kg	34.0	34.0	35.0	35.0	
	Panel TB03	kg	11	11	11	11	
	20'GP (with panel TB03)			50	50	50	50
	40'GP (with panel TB03)			117	117	117	117
	40'HQ (with panel TB03)			133	133	133	133
Wired remote controller			Z4E351B	Z4E351B	Z4E351B	Z4E351B	
Wireless remote controller			YB1FA(X-FAN)	YB1FA(X-FAN)	YB1FA(X-FAN)	YB1FA(X-FAN)	

Model			FP-160XD/B-T	FP-160XD/B-T	FP-180XD/B-T	FP-180XD/B-T
Code			EM520N0860	EM520N0850	EM520N0840	EM520N0830
Power system	Type	V-Ph-Hz	208-230V~ 60Hz	220-240V~ 50Hz	208-230V~ 60Hz	220-240V~ 50Hz
	Input	W	140	152	160	160
Air flow volume	High	CFM	912	912	1059	1059
		m ³ /h	1550	1550	1800	1800
	Medium	CFM	765	824	824	853
		m ³ /h	1300	1400	1400	1450
	Low	CFM	676	765	765	794
		m ³ /h	1150	1300	1300	1350
Capacity	Cooling	W	9000	8700	10000	9500
	Heating	W	14000	10000	16000	11000
Electric heater rated power		W	-	-	-	-
Water	Cooling water flow volume	l/s	0.43	0.42	0.48	0.45

PRODUCT

system	Heating water flow volume	l/s	0.43	0.23	0.48	0.27	
	Cooling pressure drop	kPa	34	30	42	34	
	Heating pressure drop	kPa	34	11	43	12	
Sound pressure level		dB(A)	51	51	50	50	
Coil	Type	-	Aluminum fin-copper tube	Aluminum fin-copper tube	Aluminum fin-copper tube	Aluminum fin-copper tube	
	Operating pressure	MPa	≤1.6MPa	≤1.6MPa	≤1.6MPa	≤1.6MPa	
Motor	Type	-	FN35C	FN35C	FN50K-2	FN50K-2	
	Capacitor	μF	6.00	4.50	3.50	3.50	
Connection pipe size	Water inlet & outlet	inch	G3/4	G3/4	G3/4	G3/4	
	Condensing water drain	mm	25	25	25	25	
Outline dimension (WxDxH)	Body	mm	840×840×240	840×840×240	840×840×320	840×840×320	
	Panel TB03	mm	950×950×85	950×950×85	950×950×85	950×950×85	
Package dimension (WxDxH)	Body	mm	963×963×325	963×963×325	963×963×409	963×963×409	
	Panel TB03	mm	1033×1038×133	1033×1038×133	1033×1038×133	1033×1038×133	
Net weight	Body	kg	27.0	27.0	32.0	32.0	
	Panel TB03	kg	7	7	7	7	
Gross weight	Body	kg	35.0	35.0	41.0	41.0	
	Panel TB03	kg	11	11	11	11	
	20'GP (with panel TB03)			50	50	42	42
	40'GP (with panel TB03)			117	117	98	98
	40'HQ (with panel TB03)			133	133	112	112
Wired remote controller			Z4E351B	Z4E351B	Z4E351B	Z4E351B	
Wireless remote controller			YB1FA(X-FAN)	YB1FA(X-FAN)	YB1FA(X-FAN)	YB1FA(X-FAN)	

PRODUCT

Model			FP-200XD/B-T	FP-200XD/B-T	
Code			EM520N0820	EM520N0810	
Power system	Type	V-Ph-Hz	208-230V~ 60Hz	220-240V~ 50Hz	
	Input	W	230	210	
Air flow volume	High	CFM	1176	1176	
		m ³ /h	2000	2000	
	Medium	CFM	912	1000	
		m ³ /h	1550	1700	
	Low	CFM	735	853	
		m ³ /h	1250	1450	
Capacity	Cooling	W	13000	13000	
	Heating	W	19000	14600	
Electric heater rated power		W	-	-	
Water system	Cooling water flow volume	l/s	0.62	0.62	
	Heating water flow volume	l/s	0.62	0.25	
	Cooling pressure drop	kPa	35	34	
	Heating pressure drop	kPa	35	30	
Sound pressure level		dB(A)	55	55	
Coil	Type	-	Aluminum fin-copper tube	Aluminum fin-copper tube	
	Operating pressure	MPa	≤1.6MPa	≤1.6MPa	
Motor	Type	-	FN50K-2	FN50K-2	
	Capacitor	μF	5.00	5.00	
Connection pipe size	Water inlet & outlet	inch	G3/4	G3/4	
	Condensing water drain	mm	25	25	
Outline dimension (WxDxH)	Body	mm	840×840×320	840×840×320	
	Panel TB03	mm	950×950×85	950×950×85	
Package dimension (WxDxH)	Body	mm	963×963×409	963×963×409	
	Panel TB03	mm	1033×1038×133	1033×1038×133	
Net weight	Body	kg	33.0	33.0	
	Panel TB03	kg	7	7	
Gross weight	Body	kg	42.0	42.0	
	Panel TB03	kg	11	11	
	20'GP (with panel TB03)			42	42
	40'GP (with panel TB03)			98	98
	40'HQ (with panel TB03)			112	112
	Wired remote controller			Z4E351B	Z4E351B
Wireless remote controller			YB1FA(X-FAN)	YB1FA(X-FAN)	

PRODUCT

Model			FP-200XD/D-K	
Code			EM520N1210	
Power system	Type	V-Ph-Hz	220-240V~ 50Hz	
	Input	W	140	
Air flow volume	High	CFM	1177	
		m ³ /h	2000	
	Medium	CFM	1000	
		m ³ /h	1700	
	Low	CFM	853	
		m ³ /h	1450	
Capacity	Cooling	W	12000	
	Heating	W	14200	
Electric heater rated power		W	-	
Water system	Cooling water flow volume	l/s	0.62	
	Heating water flow volume	l/s	0.4	
	Cooling pressure drop	kPa	34	
	Heating pressure drop	kPa	30	
Sound pressure level		dB(A)	55	
Coil	Type	-	Aluminum fin-copper tube	
	Operating pressure	MPa	≤1.6MPa	
Motor	Type	-	FN60C-ZL	
	Capacitor	μF	/	
Connection pipe size	Water inlet & outlet	inch	G3/4	
	Condensing water drain	mm	25	
Outline dimension (WxDxH)	Body	mm	840×840×320	
	Panel TB03	mm	950×950×85	
Package dimension (WxDxH)	Body	mm	963×963×409	
	Panel TB03	mm	1033×1038×133	
Net weight	Body	kg	32.0	
	Panel TB03	kg	7	
Gross weight	Body	kg	41.0	
	Panel TB03	kg	11	
	20'GP (with panel TB03)		kg	42
	40'GP (with panel TB03)		kg	98
	40'HQ (with panel TB03)		kg	112
Wired remote controller			Z4E351B	
Wireless remote controller			YB1FA(MOTO)	

PRODUCT

Model			FP-68XDT/B-K	FP-85XDT/B-K	FP-125XDT/B-K	FP-180XDT/B-K
Code			EM520N0990	EM520N0960	EM520N0970	EM520N0980
Power system	Type	V-Ph-Hz	220-240V~ 50Hz	220-240V~ 50Hz	220-240V~ 50Hz	220-240V~ 50Hz
	Input	W	82	82	135	191
Air flow volume	High	CFM	400	500	736	1059
		m ³ /h	680	850	1250	1800
	Medium	CFM	364	450	652	897
		m ³ /h	618	764	1108	1525
	Low	CFM	336	410	597	836
		m ³ /h	571	697	1014	1421
Capacity	Cooling	W	3500	4100	6000	8000
	Heating	W	6000	6800	9500	13000
Electric heater rated power		W	-	-	-	-
Water system	Cooling water flow volume	l/s	0.21	0.24	0.29	0.44
	Heating water flow volume	l/s	0.17	0.19	0.27	0.36
	Cooling pressure drop	kPa	34.14	56.71	43.07	39.65
	Heating pressure drop	kPa	76.44	86.08	91.94	102.21
Sound pressure level		dB(A)	39	40	43	50
Coil	Type	-	Aluminum fin-copper tube	Aluminum fin-copper tube	Aluminum fin-copper tube	Aluminum fin-copper tube
	Operating pressure	MPa	≤1.6MPa	≤1.6MPa	≤1.6MPa	≤1.6MPa
Motor	Type	-	FN35D-2	FN35D-2	FN35B-1	FN50K-1
	Capacitor	μF	2.0	3.0	4.0	4.5
Connection pipe size	Water inlet & outlet	inch	G3/4	G3/4	G3/4	G3/4
	Condensing water drain	mm	25	25	25	25
Outline dimension	Body	mm	840×840×190	840×840×190	840×840×240	840×840×320
	Panel TB03	mm	950×950×85	950×950×85	950×950×85	950×950×85
Package dimension	Body	mm	960×960×257	960×960×257	960×960×310	960×960×394
	Panel TB03	mm	1033×1038×133	1033×1038×133	1033×1038×133	1033×1038×133
Net weight	Body	kg	25.0	25.0	27.0	32.0
	Panel TB03	kg	7	7	7	7
Gross weight	Body	kg	33.0	33.0	34.0	41.0
	Panel TB03	kg	11	11	11	11
Loading quantity	20'GP (with panel TB03)		56	56	50	42
	40'GP (with panel TB03)		131	131	121	98
	40'HQ (with panel TB03)		147	147	134	112

PRODUCT

2 pipes

Model			FP-51XD/A-K	FP-68XD/A-K	FP-85XD/B-T (E)	FP-102XD/B-T (E)
Power system	Type	V-Ph-Hz	220-240V~ 50Hz	220-240V~ 50Hz	220-240V~ 50Hz	220-240V~ 50Hz
	Input	W	73	78	81	110
Air flow volume	High	CFM	300	388	471	470
		m ³ /h	510	660	800	940
	Medium	CFM	235	330	385	453
		m ³ /h	400	560	665	770
	Low	CFM	176	270	347	394
		m ³ /h	300	460	590	670
Capacity	Cooling	W	2750	3400	4500	5000
	Heating	W	3400	3800	5400	6100
Electric heater rated power		W	-	-	-	-
Water system	Cooling water flow volume	l/s	0.13	0.18	0.22	0.24
	Heating water flow volume	l/s	0.16	0.20	0.27	0.29
	Cooling pressure drop	kPa	30	38	27	34
	Heating pressure drop	kPa	30	38	37	46
Sound pressure level		dB(A)	46	46	39	49
Coil	Type	-	Aluminum fin-copper tube	Aluminum fin-copper tube	Aluminum fin-copper tube	Aluminum fin-copper tube
	Operating pressure	MPa	≤1.6MPa	≤1.6MPa	≤1.6MPa	≤1.6MPa
Motor	Type	-	FN30L	FN30L	FN35D-2	FN35D-2
	Capacitor	μF	2.0	2.0	2.0	3.5
Connection pipe size	Water inlet & outlet	inch	G3/4	G3/4	G3/4	G3/4
	Condensing water drain	mm	25	25	25	25
Outline dimension (WxDxH)	Body	mm	664x594x292	670x670x60	670x670x60	840x840x190
	Panel	mm	670x670x60	670x670x60	950x950x85	950x950x85
Package dimension (WxDxH)	Body	mm	778x733x300	775x730x285	963x963x272	963x963x272
	Panel	mm	673x673x85	778x733x300	1033x1038x133	1033x1038x133
Net weight	Body	kg	20	20	25.0	25.0
	Panel	kg	3.5	3.5	7	7
Gross weight	Body	kg	24	24	33.0	33.0
	Panel	kg	5	5	11	11
Loading quantity	20'GP (with panel)		147	147	56	56
	40'GP (with panel)		315	315	131	131
	40'HQ (with panel)		360	360	147	147

PRODUCT

Model			FP-125XD/B -T (E)	FP-140XD/B -T (E)	FP-160XD/B -T (E)	FP-180XD/B -T (E)	FP-200XD/ D-K (E)
Power system	Type	V-Ph-Hz	220-240V~ 50Hz	220-240V~ 50Hz	220-240V~ 50Hz	220-240V~ 50Hz	208-230V~ 60Hz
	Input	W	100	143	152	160	140
Air flow volume	High	CFM	641	823	882	964	1000
		m ³ /h	1090	1400	1500	1640	1700
	Medium	CFM	506	682	706	800	841
		m ³ /h	860	1160	1200	1360	1430
	Low	CFM	447	588	588	706	676
		m ³ /h	760	1000	1000	1200	1150
Capacity	Cooling	W	6000	7400	8400	9500	11100
	Heating	W	6900	8400	9000	10500	11700
Electric heater rated power		W	-	-	-	-	-
Water system	Cooling water flow volume	l/s	0.29	0.35	0.4	0.45	0.53
	Heating water flow volume	l/s	0.33	0.4	0.43	0.49	0.56
	Cooling pressure drop	kPa	21	30	30	33	21
	Heating pressure drop	kPa	32	38	36	41	25
Sound pressure level		dB(A)	43	50	51	50	55
Coil	Type	-	Aluminum fin-copper tube	Aluminum fin-copper tube	Aluminum fin-copper tube	Aluminum fin-copper tube	Aluminum fin-copper tube
	Operating pressure	MPa	≤1.6MPa	≤1.6MPa	≤1.6MPa	≤1.6MPa	≤1.6MPa
Motor	Type	-	FN35B-1	FN35C	FN35C	FN50K-2	FN60C-ZL
	Capacitor	μF	2	4	4.5	3.5	-
Connection pipe size	Water inlet & outlet	inch	G3/4	G3/4	G3/4	G3/4	G3/4
	Condensing water drain	mm	25	25	25	25	25
Outline dimension (WxDxH)	Body	mm	840x840x240	840x840x240	840x840x240	840x840x320	840x840x320
	Panel TB03	mm	950x950x85	950x950x85	950x950x85	950x950x85	950x950x85
Package dimension (WxDxH)	Body	mm	963x963x325	963x963x325	963x963x325	963x963x409	963x963x409
	Panel TB03	mm	1033x1038x133	1033x1038x133	1033x1038x133	1033x1038x133	1033x1038x133
Net weight	Body	kg	27	27	27	32	33
	Panel TB03	kg	7	7	7	7	7

PRODUCT

Gross weight	Body	kg	34	35	35	41	42
	Panel TB03	kg	11	11	11	11	11
	20'GP (with panel TB03)		50	50	50	42	42
	40'GP (with panel TB03)		117	117	117	98	98
	40'HQ (with panel TB03)		133	133	133	112	112

4 pipes

Model			FP-68XDT/B-K (E)	FP-85XDT/B-K (E)	FP-125XDT/B-K (E)	FP-180XDT/B-K (E)
Power system	Type	V-Ph-Hz	220-240V~ 50Hz	220-240V~ 50Hz	220-240V~ 50Hz	220-240V~ 50Hz
	Input	W	82	90	135	191
Air flow volume	High	CFM	400	500	736	1000
		m ³ /h	680	850	1250	1700
	Medium	CFM	364	450	652	897
		m ³ /h	618	764	1108	1525
	Low	CFM	336	410	597	836
		m ³ /h	571	697	1014	1421
Capacity	Cooling	W	3500	4500	6000	8000
	Heating	W	5800	6800	9200	12000
Electric heater rated power		W	-	-	-	-
Water system	Cooling water flow volume	l/s	0.21	0.24	0.29	0.44
	Heating water flow volume	l/s	0.17	0.19	0.27	0.36
	Cooling pressure drop	kPa	44	53	41	48
	Heating pressure drop	kPa	76	83	84	97
Sound pressure level		dB(A)	39	40	43	50
Coil	Type	-	Aluminum fin-copper tube	Aluminum fin-copper tube	Aluminum fin-copper tube	Aluminum fin-copper tube
	Operating pressure	MPa	≤1.6MPa	≤1.6MPa	≤1.6MPa	≤1.6MPa
Motor	Type	-	FN35D-2	FN35D-2	FN35B-1	FN50K-2
	Capacitor	μF	2.0	3.0	4.0	4.5
Connection pipe size	Water inlet & outlet	inch	G3/4	G3/4	G3/4	G3/4
	Condensing water drain	mm	25	25	25	25
Outline dimension	Body	mm	840×840×190	840×840×190	840×840×240	840×840×320
	Panel TB03	mm	950×950×85	950×950×85	950×950×85	950×950×85
Package dimension	Body	mm	960×960×257	960×960×257	960×960×310	960×960×394
	Panel TB03	mm	1033×1038×133	1033×1038×133	1033×1038×133	1033×1038×133

PRODUCT

Net weight	Body	kg	25.0	25.0	27.0	32.0
	Panel TB03	kg	7	7	7	7
Gross weight	Body	kg	33.0	33.0	34.0	41.0
	Panel TB03	kg	11	11	11	11
Loading quantity	20'GP (with panel TB03)		56	56	50	42
	40'GP (with panel TB03)		131	131	121	98
	40'HQ (with panel TB03)		147	147	134	112

Testing condition:

For 60Hz :

The FCU designed for installation indoor. The environmental temperature is from 5°C to 43°C, water working temperature is from 7°C to 60°C.

The temperature exchange efficiency and enthalpy exchange efficiency are tested under these testing conditions as below:

- (a) Cooling capacity: air 27°C DB, 19.5°C WB, water temperature: intake 7°C, outlet 12°C.
- (b) Heating capacity: air 21°C DB, Water temperature intake 60°C, the water-flow volume is same as Cooling capacity .
- (c) Freeze-up : air 27°C DB, 24°C WB, water temperature intake 6°C, outlet 9°C.
- (d) Sound power level according to ISO 5151. Sound pressure level are calculated at the below of air-outlet 1m and 1m distance. The noise are tested before leaving factory.

For 50 Hz :

The FCU designed for installation indoor. The environmental temperature is from 5°C to 43°C, water working temperature is from 7°C to 60°C.

The temperature exchange efficiency and enthalpy exchange efficiency are tested under these testing conditions as below:

- (a) Cooling capacity: air 27°C DB , 19°C WB, water temperature intake 7°C, outlet 12°C.
- (b) Heating capacity: air 20°C DB , Water temperature intake 50°C, outlet 40°C.
For the tow-row coils applicable to EU, the entering/leaving water temperature is 45°C and 40°C.
- (c) Freeze-up : air 27°C DB, 24°C WB , water temperature 6°C intake , 10°C outlet .
- (d) Sound power level according to ISO 5151. Sound pressure level are calculated at the below of air-outlet 1m and 1m distance. The noise are tested before leaving factory.

For 4 pipes:

The FCU designed for installation indoor. The environmental temperature is from 5°C to 43°C, water working temperature is from 7°C to 70°C.

The temperature exchange efficiency and enthalpy exchange efficiency are tested under these testing conditions as below:

- (a) Cooling capacity: air 27°C DB , 19°C WB, water temperature intake 7°C, outlet 12°C.
- (b) Heating capacity: air 20°C DB , Water temperature intake 70°C, outlet 60°C.
and for the four-row coils, the entering/leaving water temperature is 65°C /55°C.
- (c) Freeze-up : air 27°C DB, 24°C WB , water temperature 6°C intake , 10°C outlet .
- (d) Sound power level according to ISO 5151. Sound pressure level are calculated at the below of air-outlet 1m and 1m distance. The noise are tested before leaving factory.

II CONTROL

1. WIRELESS REMOTE CONTROLLER

1.1 YB1FA(X-FAN)

Note:

- Be sure that there are no obstructions between receiver and remote control; Donot drop or throw the remote control; Don't let any liquid drop into the remote control or leave the remote control under the sunlight or place where is very hot.
- This is a general remote control, it could be used for multiple types (functions) of air conditioners. For some models without the functions specified here, we preserve the right to not to inform exclusively.

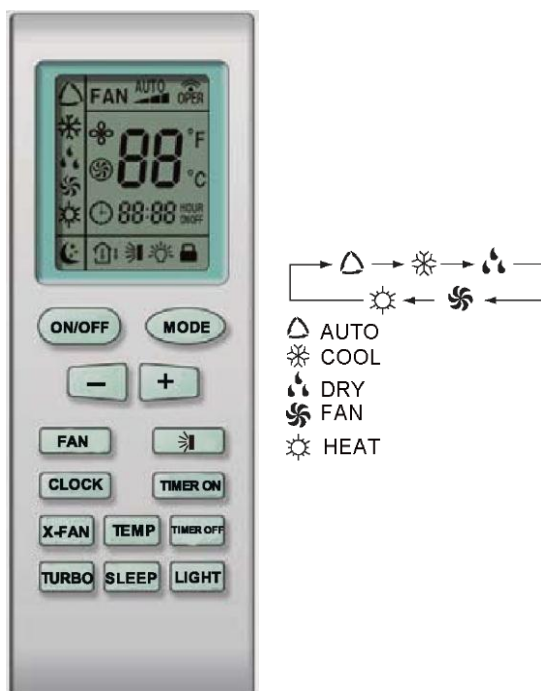

(1) ON/OFF button

Press ON/OFF button to turn on/off the unit. When the unit is turned off, the Timer, Sleep function will not be retained in memory, but the time will be retained and is still displaying.

(2) MODE button

Press this button, Auto, Cool, Dry, Fan Heat mode can be selected circularly.

Auto mode is not available in this mode.

(3) SLEEP button

Press this button to select Sleep On/Sleep Off. If power is on, Sleep Off is default. If the unit is turned off, the Sleep function setting will be not retained in memory. If Sleep function is on, the mark of Sleep will display. In this mode, the time of timer can be adjusted. Under Fan and Auto modes, this function is not available.

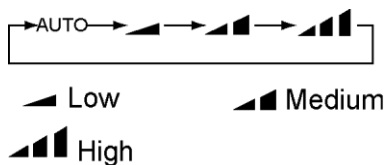

(4) FAN button

Press this button, Auto, Low, Medium, High-speed can be circularly selected. After powered on, Auto fan speed is default. Under Dehumidify mode, Low fan speed is default.





Note: Under the Dry mode, the fan speed isn't adjustable, low fan speed is default.

(5) CLOCK button

Press Clock button to set the time of clock. When  blinks and displays, you can set the time by pressing + or - button. If no button is pressed within 10 seconds the remote will revert back to the normal display. Press  again to accept the setting. If it is set the first time, 12:00 is the initial value. Note: If mark  displays on the LCD, it means it is the time of clock, if not, it is the time of timer.

(6) LIGHT button

Press this button to select LIGHT On/Off in the displayer. When the LIGHT On is set, the mark  will be displayed and the indicator light in the displayer will be on. When the LIGHT Off is set, the mark  will disappear and the indicator light will be off. The function is not available for this mode.

(7) X-FAN button

Press this button to turn on/off the X-FAN function.

The function is not available for this mode.

(8) - button

Pressing temperature can be decrease the temperature by 1 degree Celsius once. press and hold for more than two seconds so that we can change the temperature continuously. The minimum and maximum setting range of the temperature is 16 to 30 degree Celsius.

(9) + button

Press this button increase the temperature by 1 degree Celsius once. Press and hold for more than two seconds so that we can change the temperature continuously. The minimum and maximum setting range of the temperature is 16 to 30 degree.

(10) TEMP button

Press this button to select the display of either indoor setting temperature or indoor ambient temperature. When the indoor unit powered on firstly, setting temperature display is default. Change status to  to display the ambient temperature. If not received control signal in 5 seconds, the display temp. will revert back to setting temperature. When unit is off, indoor setting temperature display is default. Note: This function is only available for certain models.

(11) TURBO button



In Cool or Heat mode, press this button to turn on/off the Turbo function.

Note: This is a general remote control, it could be used for multiple types (functions) of air conditioners. For some models without the functions specified here, we preserve the right to not to inform exclusively.

(12) SWING UP AND DOWN button

Press this button to adjust swing angle, which circularly changes as below:



This is a universal wireless remote controller; however, the unit covered in this manual is only of the simplified SWING function. As a result, when the wireless remote controller is energized initially with the unit under the OFF status, this simplified function should be set by pressing the + button and the SWING button simultaneously, with the symbol  blinking twice. Then, after the unit is turned on, this function can be activated or deactivated simply by pressing the SWING button, with the displayed symbol  indicating this function is on and without this displayed symbol indicating this function is off.



(13) TIMER ON button

Press the TIMER ON button to set the timed On. Press +/- once to increase or decrease the minute by 1 minute. If pressed and held for 2 seconds, the minute will increase or decrease constantly by 1 minute. If held constantly for more than 5 seconds, the minute will begin to change in every 10 minutes. Press TIMER ON again to accept the setting and ON will show besides the time of clock meaning the setting succeeds. Press the TIMER ON again to cancel the setting.

(14) TIMER OFF button

Press the TIMER OFF button to set the timed off. The procedures are similar as above.



1.1.1 Operation of wireless remote control

(1) Guide for operation – General operation

- Press SLEEP button to set the sleep state.
- Press TIME ON and TIME OFF button to scheduled the unit ON/OFF.
- Press LIGHT button to control on and off the indicator board.(This function maybe not available for some units.)



(2) Guide for operation-Optional operation

- After powered on, press ON/OFF button, the unit will start to run. (Note: When it is powered off , the guide louver of main unit will close automatically.)
- Press MODE button, select desired running mode ,or press COOL or HEAT mode to enter the corresponding operation directly.
- Press + or - button to set the desired temperature.
- Press FAN button to set fan speed from AUTOFAN , LOW , MID and HIGH.
- Press  button to select SWING mode.
- Press + and - buttons simultaneously to lock or unlock the wireless remote control. If it is locked, the mark will display; when pressing any button, the mark  will blink for three times but the air conditioner has no response. If unlocked, the mark will disappear.
- Switch between Fahrenheit and Centigrade.

When unit is under Off state, press MODE and – button simultaneously to switch between °C and °F.

1.1.2 Changing batteries and notices.

Slightly to press the place with  , along the arrowhead direction to push the back cover of wireless remote control. (As show in figure)

Take out the old batteries. (As show in figure.)

Insert two new AAA1.5V dry batteries, and pay attention to the polarity. (As show in figure)

Attach the back cover of wireless remote control. (As show in figure)

NOTE:

- (a) The design of this unit conforms to the requirements of ISO5151 standard.
- (b) The air volume is measured at the 0Pa external static pressure.
- (c) Cooling (heating) capacity stated above is measured under nominal working conditions corresponding to 0Pa external static pressure. The parameters are subject to change with the improvement of products, in which case the values on the nameplate will prevail.

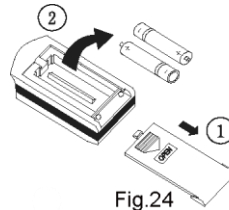

Fig.24

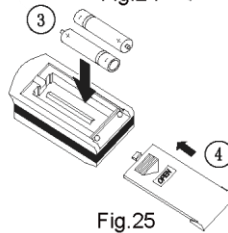
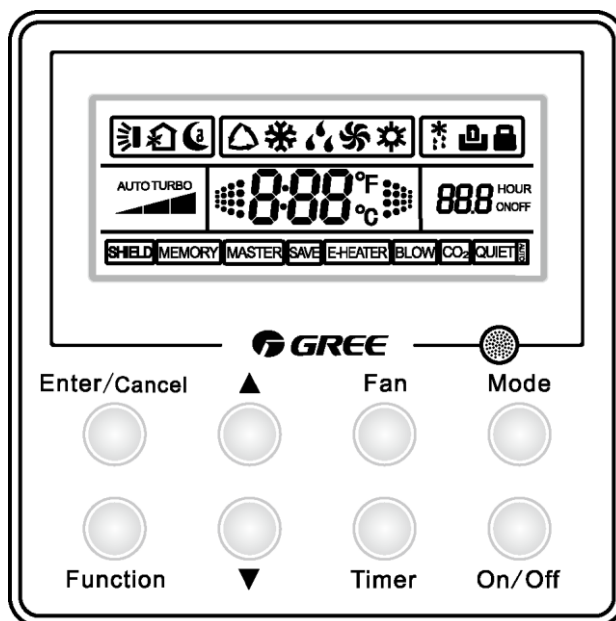

Fig.25

Sketch map for
changing batteries

2. WIRED REMOTE CONTROLLER

2.1 Introduction to Z4E351B (optional)





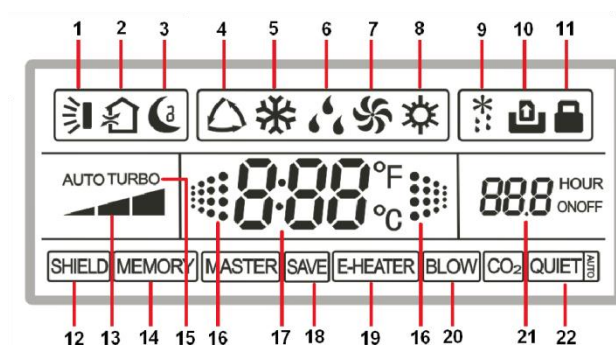













2.1.1 Symbols on the LCD



Introduction to the Symbols on the LCD.

No.	Symbol	Function Description
1		It indicates the swing function.
2		It indicates the function of air exchange. (It is unavailable for this wired controller.)
3		It indicates the sleeping status.
4		It indicates each running mode of the indoor unit (AUTO mode). (It is unavailable for this wired controller.)
5		It indicates the “ Cool ” mode.

CONTROL

6		It indicates the “ Dry ” mode.
7		It indicates the “ Fan ” mode.
8		It indicates the “ Heat ” mode.
9		It indicates the defrosting mode. (It is unavailable for this wired controller.)
10		It indicates the gate control status.
11		It indicates the locking status.
12		It indicates the shield status. (It appears when all functions, or the function “On/Off”, “Temp”, “Mode”, or “Save” is shielded through the Long-distance monitoring System.)
13		It indicates the current fan speed.
14		It indicates the memory function is activated, that is, the unit will back to the previous set status after powered on again.
15	TURBO	It indicates the turbo status.
16		It flashes animatedly when the unit is started and the ambient temperature is displayed.
17		It indicates the ambient temperature/set temperature.
18		It indicates the energy saving status.
19		It indicates that the auxiliary electric heater can be activated.
20		It indicates the blow function is activated.
21		It indicates the timer status.
22		It indicates the quiet operation status. (including two statuses, “ Quiet ” and “ Auto Quiet ”.)

Note: Symbols “ MASTER ” and “ CO2 ” will not displayed on the LCD of the wired controller XK26.

2.1.2 Introduction to the Functions of the Press Keys

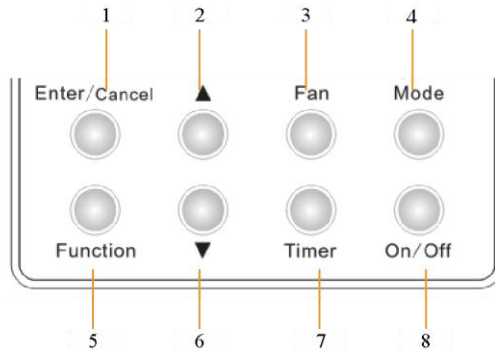

Introduction to the Functions of the Press Keys.

No.	Press Bottoms	Function Description
1	Enter/Cancel	It is used to select the desired function or cancel the selected function.
2	▲	① It is used to adjust the running temperature of the indoor unit among 16~30 ℃ . ② It is used to adjust the temperature under the energy saving condition among 16~30 ℃ .
6	▼	③ It is used to adjust the timer among 0.5~24 hours. ④ It is used to switch between the modes of “ Quiet ” and “ Auto Quiet ” .
3	Fan	There are four fan speed options, High, Medium, Low and Auto.
4	Mode	① It is used to set the mode of “ Cool ”, “ Dry ”, “ Fan ”, and “ Heat ” . ② When the “ Save ” function is being set, it is used to switch between the mode options of “ Heat ” and “ Cool ” . ③ When the “ Timer ” is being set, it is used to switch between the options of “ Unit On ” and “ Unit Off ” .
5	Function	It is used to switch the functions of “ Swing ”, “ Sleep ”, “ Turbo ”, “ Save ”, “ E-Heater ”, “ Blow ”, “ Quiet ”, etc.
7	Timer	It is used to set the timer.
8	On/Off	It is used to start/stop the indoor unit.
4 + 2	Mode + ▲ (MEMORY)	Under the “ Off ” status of the unit, press “ Mode ” and “ ▲ ” simultaneously for five seconds to activate or deactivate the “ MEMORY ” function. (once this function is activated, the unit with power failure will resume the previous set status after powered on again; otherwise it will go to the “ Off ” status.)
2 + 6	▲ + ▼ (LOCK)	Press “ ▲ ” and “ ▼ ” simultaneously for five seconds to go to the lock status, in which case the press on any other key will get no response. And another press on “ ▲ ” and “ ▼ ” for five seconds will quit this status.

CONTROL

5+ 7	Function +Timer (Ambient Temperature Sensor; Anti Cold/Hot Air)	Under the "Off" status of the unit, press "Function" and "Timer" simultaneously for five seconds to call out the debugging menu, after that press "Mode" to select the desired submenu and press "▲"/"▼" to set the parameter, finally press "Enter/Cancel" to save the setting and quit the setting status.
4 +6	Mode +▼	Under the "Off" status of the unit, press "Mode" and "▼"simultaneously for five seconds to switch the Celsius scale and Fahrenheit scale.

III UNIT INSTALLATION

1. SELECTION THE MOUNTING POSITION

Especially, the installation place is very important for the fan coil unit because it is very difficult to move from place after the first installation.

Decide the mounting position together with the customer as follows:

The discharge direction can be selected as shown below.

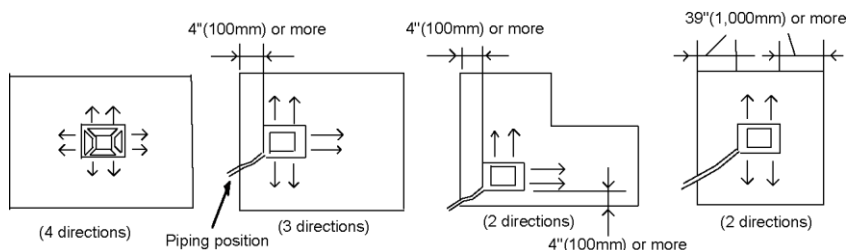

Since 2-way outlet causes performance problems, do not set it.

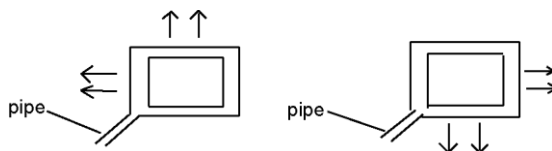

Install the indoor unit on a place having a sufficient strength so that it with stands against the weight of the unit.

The inlet and outlet ports should not be obstructed; the air should be able to blow all over the room.

Leave the space required to service the air conditioner.

The ceiling rear height is 9-3/8 inches(250mm) or more.

A place from where the air can be distributed evenly throughout the room by the unit.

A place from where drainage can be extracted outdoor easily.

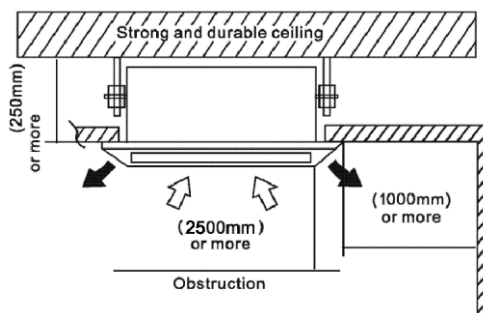

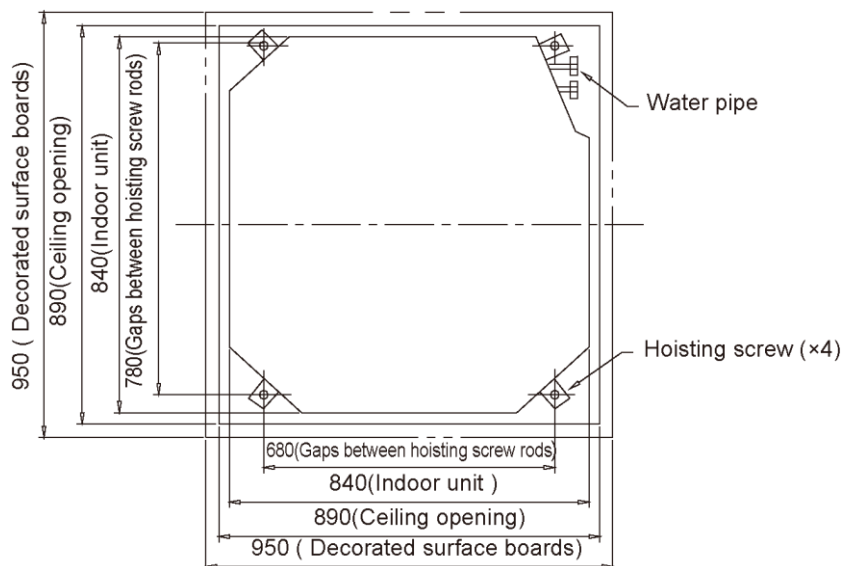

Be suitable for:

P-85XD/B-T; FP-102XD/B-T; FP-125XD/B-T; FP-140XD/B-T; FP-160XD/B-T; FP-180XD/B-T; FP-200XD/B-T; FP-85XD/B-T; FP-102XD/B-T; FP-125XD/B-T; FP-140XD/B-T; FP-160XD/B-T; FP-180XD/B-T; FP-200XD/B-T; FP-68XDT/B-K; FP-85XDT/B-K; FP-125XDT/B-K; FP-180XDT/B-K;

2. DRAINAGE PIPE

The diameter of the drain pipe should be greater than or equal to the diameter of the connecting pipe [vinyl tube, pipe size: Outer diameter 25mm (outer dimension)].

Keep the drainage pipe short and sloping downwards at a gradient of at least 1/100 to prevent air pockets from forming.

If the drainage hose cannot be sufficiently set on, add a drainage raising pipe.

To keep the drainage hose from sagging, keep space between hanging hooks at 1~1.5m.

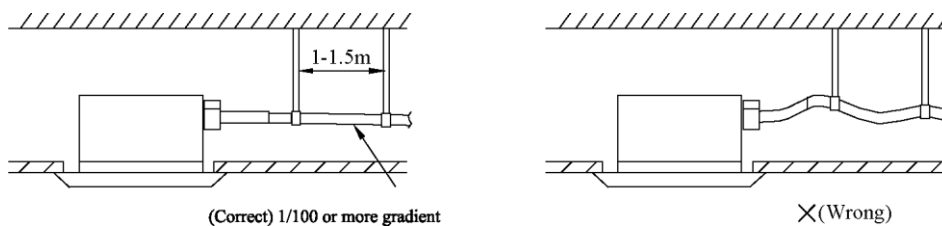

Use the drain hose and clamp attached. Insert the drain hose to the drain vent, and then tighten the clamp.

Entwine the big sponge on the clamp of drain hose to insulate heat.

Heat insulation should be done to indoor drain hose.

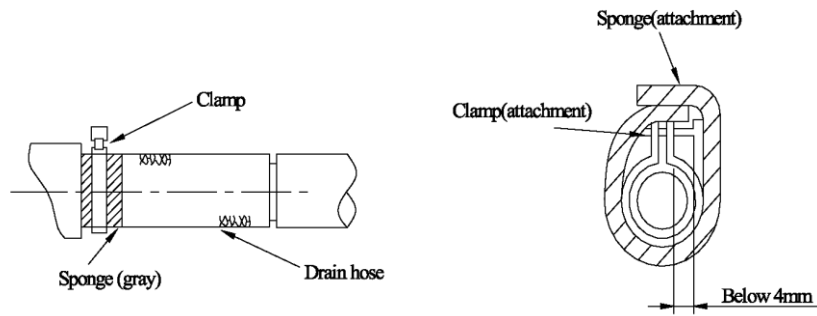

3. PRECAUTIONS FOR DRAINAGE RAISING PIPE

The install height of the drain raising pipe should less than 280mm.

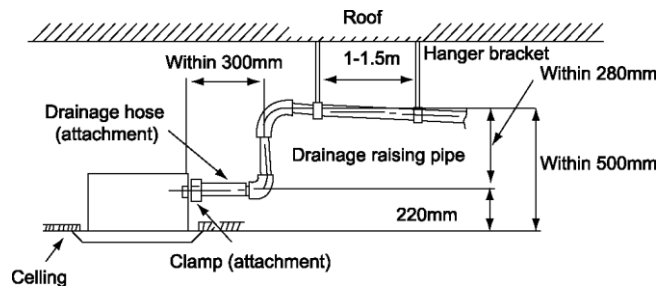

The drain raising pipe should form a upright angle with the unit, and distance to unit should not beyond 300mm.

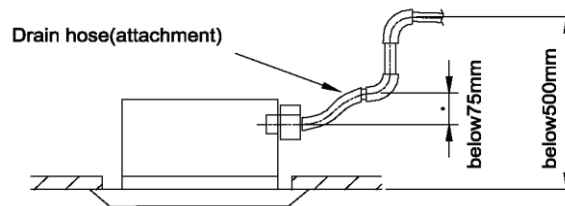

3.1 Instruction

- (1) The slant gradient of the attached drain hose should be within 75mm so that the drain hole doesn't has to endure the unnecessary outside force.
- (2) Please install the drain hose according to the following process if several drain hoses join together.

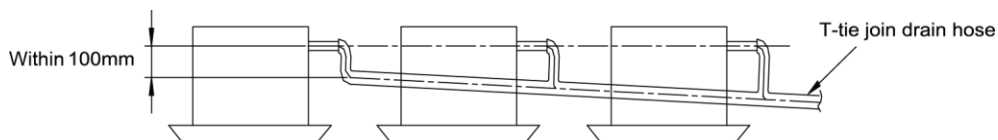

The specs of the selected join drain hose should fits the running capacity of the unit

- (3) The installation of the motorized valve should be done according as .Firstly connect one end of the tube joint with the water inlet tube of the unit, then connect the other end with the motorized valve, and lastly connect the motorized valve with the flare nut . During the installation, both the torque wrench and the spanner should be used and the moment of torque should be within 90 N.m. Besides, a secure connection should be guaranteed.

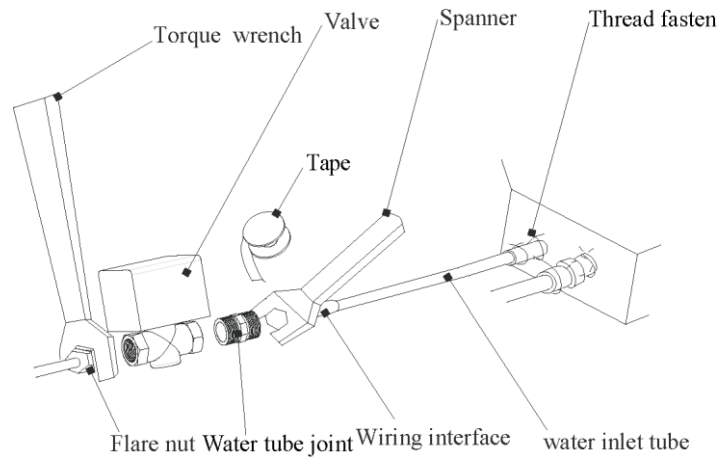

- (4) Both the tube joint and the motorized valve are G3/4 threaded. Prior to the connection, it is recommended to wrap the tacky tape on the thread for two or three cycles for better sealing effects .
- (5) After the tube joint, motorized valve, water inlet tube, water outlet tube are connected reliably, start the water pump of the outdoor unit to check if they leak or not.
- (6) What should be done lastly is wrapping sponge around the motorized valve and the tube for heat insulation.

● For 2 pipes:

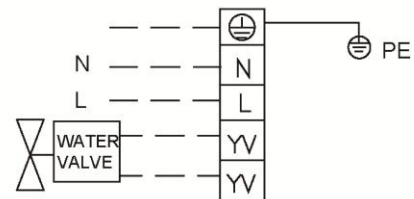
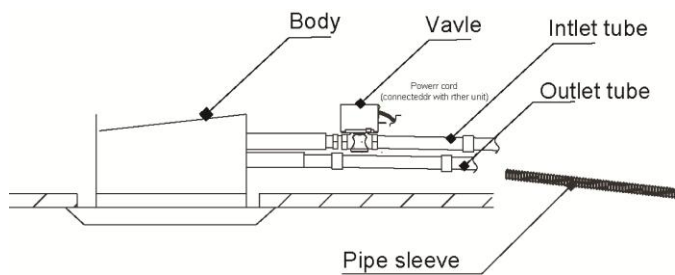

● For 4 pipes:

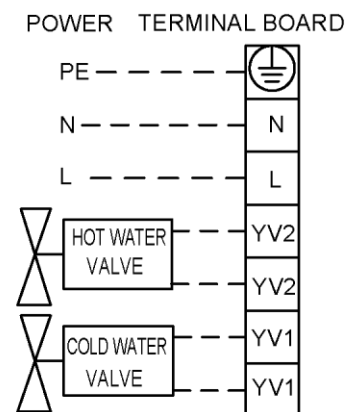
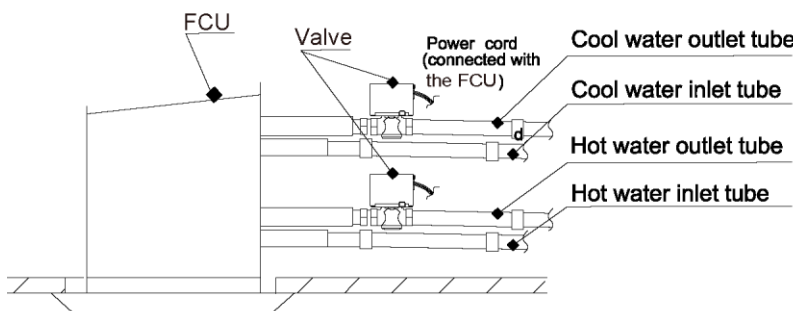

- (7) Check the smoothness of drain after installation.
- (8) Check the drain state by imitating 600cc water slowly from the outlet vent or test hole.
- (9) Check the drain in the state of refrigerating after installation of the electric circuit.

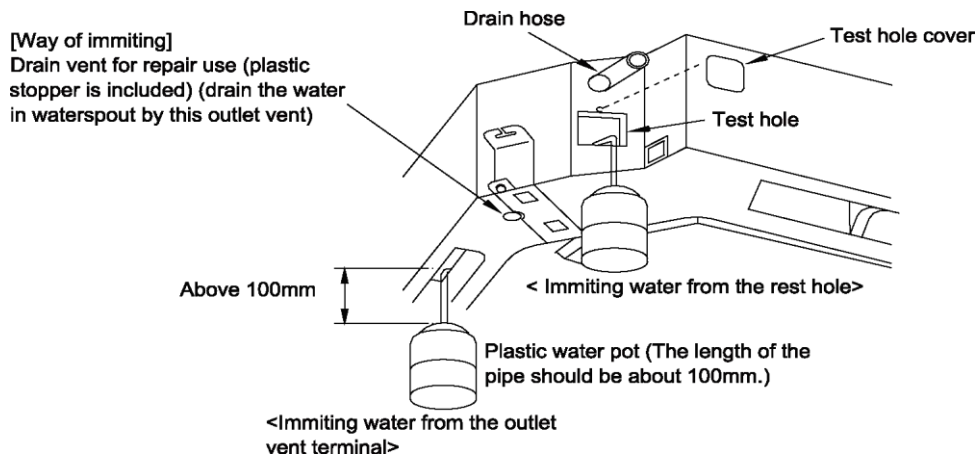

Warning: Before obtaining access to terminals, all supply circuits must be disconnected.

4. ELECTRIC WIRING

- (1) All field supplied parts and materials must conform to local laws and regulations.
- (2) For electric wiring, refer to WIRING DIAGRAM attached to the unit body.
- (3) All wiring must be performed by a skilled technician.
- (4) A circuit breaker capable of shutting down power supply to the entire system and which have at least mm contact separation in each jole must be installed in the fixed wiring.
- (5) Earth properly.
- (6) Wiring must conform to national laws and regulations.
- (7) The fixed wiring must be installed with a protector with no more that 30 mA leakage current.
- (8) If the supply cord is damaged, it must be replaced by the manufactory or its service agents or a similarity qualified person in order to avoid a hazard.

4.1 Wiring of unit and the controller

4.1.1 Wiring of the unit

- (1) For 2 pipes

Remove the control box lid, pull the wires inside through rubber bush and wiring according to the WIRING DIAGRAM, then tighten it with clamp.

Wiring of the controller

- Remove the control box lid, pull wires inside through rubber bush and connect to the controller.
- Wrap the wire with sealing pad.
- After wiring, tighten it with clamp and fix the control box lid.
- Heating and cooling: connect the rubber wire (5-cords) to the power supply terminal board in properly.
- Cooling: connect the rubber wire (3-cords) to the power supply terminal board properly.

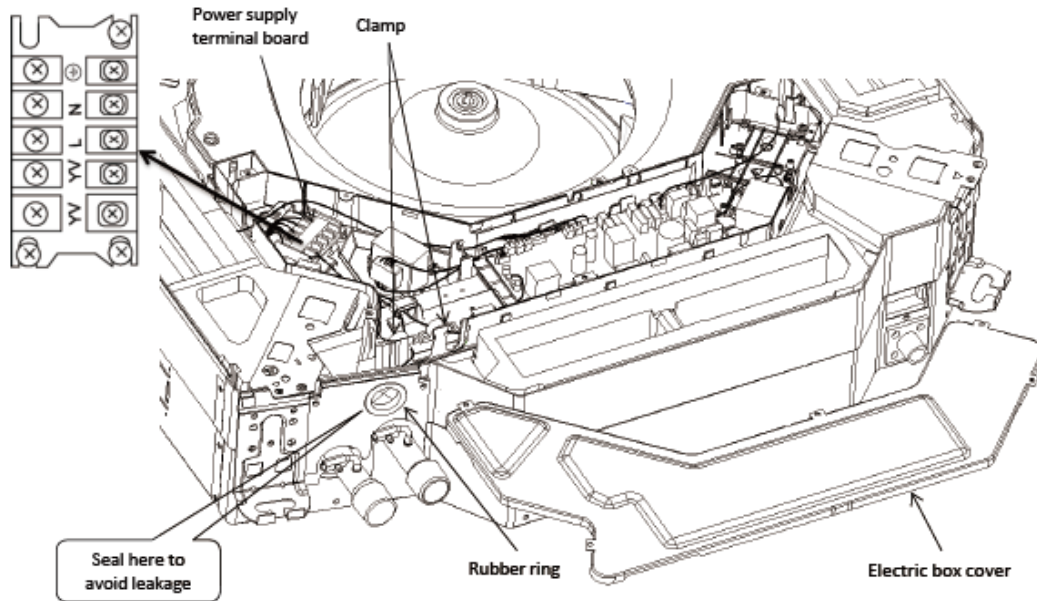

Precautions: Be sure to connect the unit at right poles.

(2) For 4 pipes

The "WIRING DIAGRAM" in the manual is reference. The correct wiring should agree with the "WIRING DIAGRAM" on controller box of the unit.

- Remove the control box lid (1). Pull the wires inside through rubber bush I and wiring according to the " WIRING DIAGRAM ", then tighten it with clamp.After wiring, tighten it with clamp and fix the control box lid(1).(2) .
- When the wiring is completed, take a careful check and then start the water pump and unit to see if the motorized valve works normally.

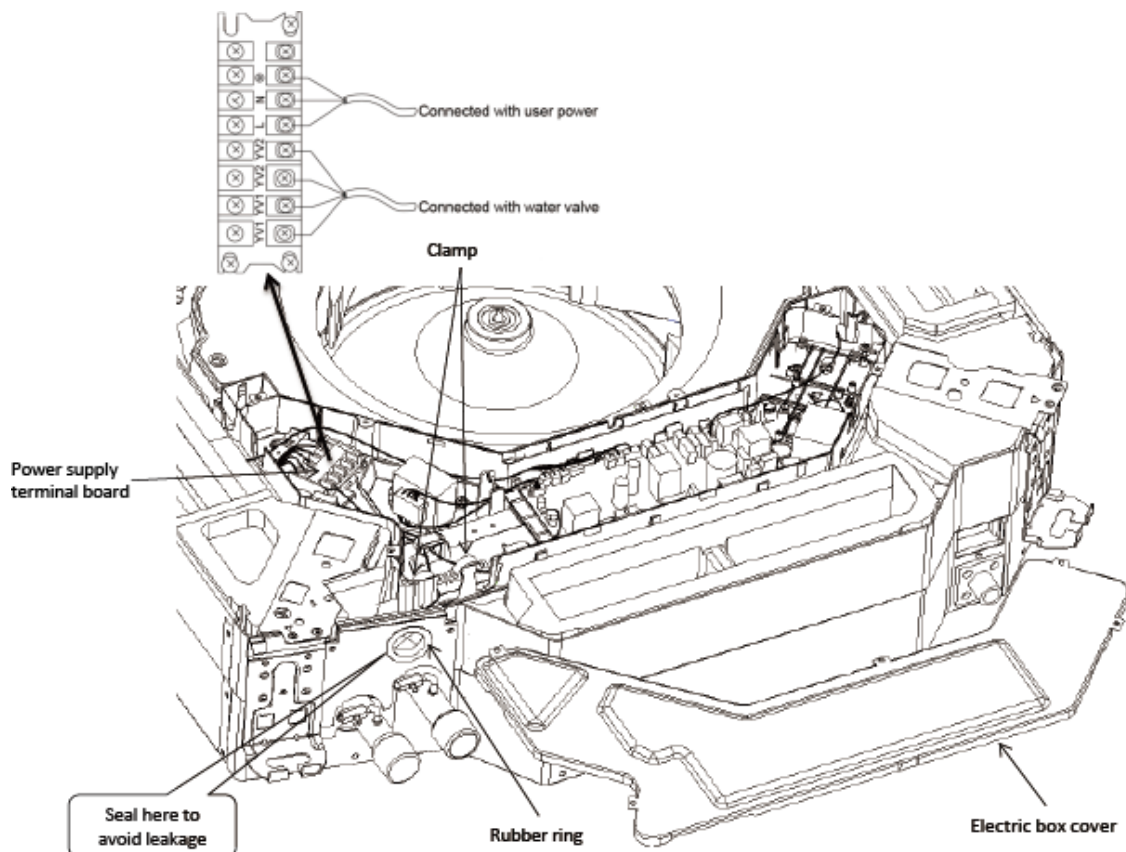

5. INSTALLATION OF PANEL

Set the panel to the unit body by matching the position of the swing flap motor of the decoration panel to the piping position of the indoor unit as shown as below.

Install the decoration panel.

- (1) Hang the latch, which is located on the opposite side of the swing flap motor on the panel, temporarily to the hook of the unit. (2 Positions)
- (2) Temporarily hang the remaining 2 latches to the hooks on the sides of the unit.(be careful not to let the swing motor lead wire get caught in the sealing material.)
- (3) Screw all 4 hexagon head screws located right beneath the latches in approximately 15mm.(panel will rise)
- (4) Adjust the panel by turning it to the arrowed direction in Fig.4 so that the ceiling opening is completely covered.
- (5) Tighten the screws until the thickness of the sealing material between the panel and the unit.
- (6) Body is reduced to 5~8 mm.

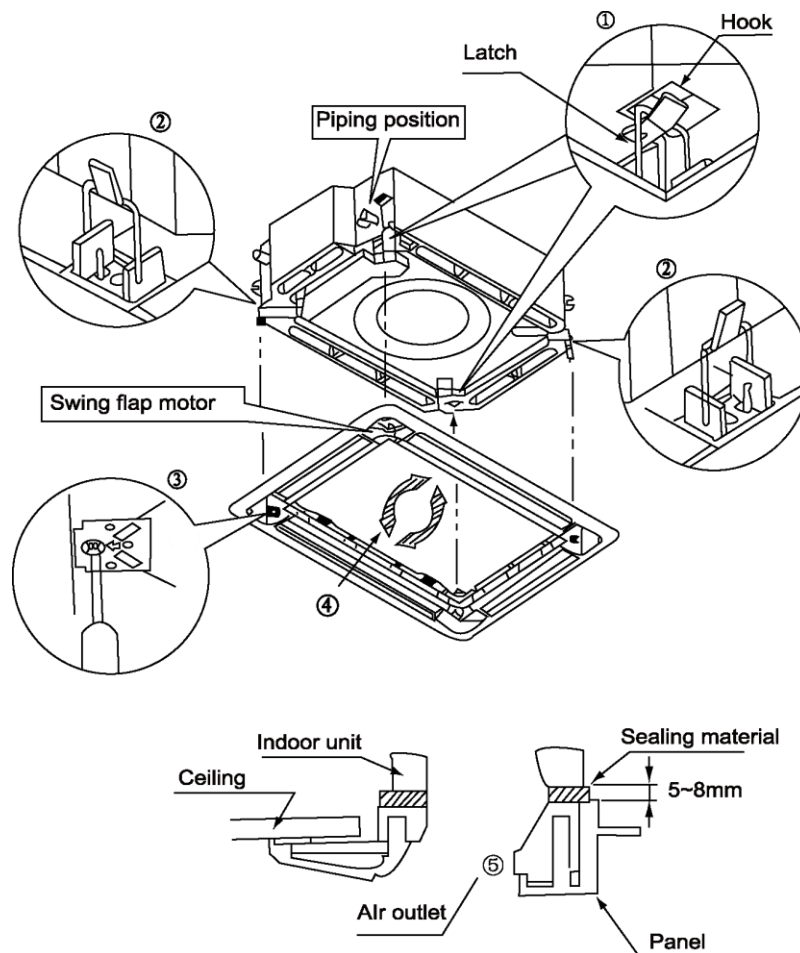

5.1 Precautions

Improper screwing of the screws may cause the troubles.

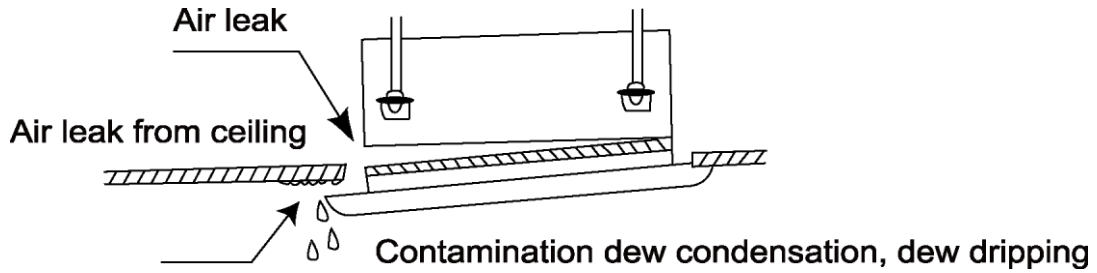

If gap is still left between the ceiling and the panel after screwing the screws, readjust the height of the unit body.

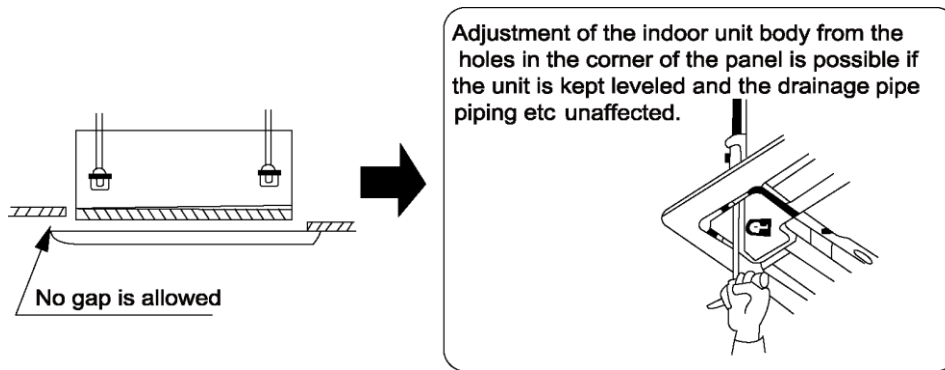

5.2 After fixing be sure no gap left between the ceiling and the panel

Wiring of the decoration panel.

Connect the joints for swing flap motor lead wire (at 2 places) installed on the panel.

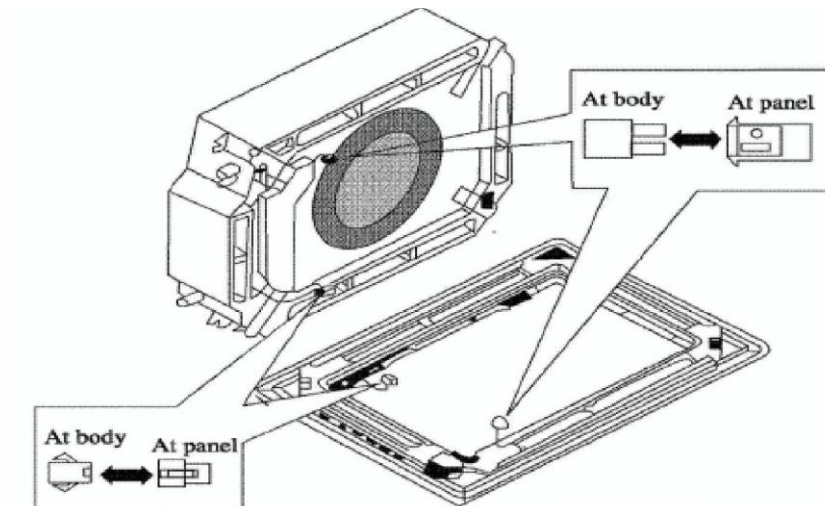

IV Unit MAINTENANCE

1.TROUBLESHOOTING

Panel TB03 displaying the error code :



Error code	Error
E0	Water pump error
E6	Communications error
F0	temperature sensor error at the return air inlet
F1	Evaporator temp. sensor error
F5	temperature sensor error at the wire controller
E9	Full water protection
FE	Entering cooling temp. sensor error of the evaporator

2.CARE AND MAINTENANCE

Please pull out the power plug after you used the air condition.

Warning:

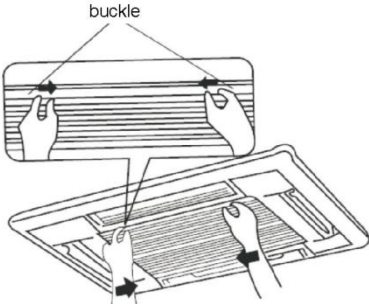
- (1) Pull out the power plug before cleaning.
- (2) Do not splash water directly.

How to clean the air filter	
<ol style="list-style-type: none"> ① Open the suction grille. ② Slide both knobs simultaneously as shown and then pull them downward slowly. 	
<ol style="list-style-type: none"> ① Remove the air filters. ② Slide knobs on the back of the suction grille out ward and remove the air filter. ③ Then remove three air cleaners on it. 	
<ul style="list-style-type: none"> ● Clean the filter <p>Use vacuum or wash the air filter with water when the air filter is very dirty, use neutral detergent and water. Let the filter dry naturally at shady place.</p> <p>Note:</p> <ol style="list-style-type: none"> a. Do not clean with hot water. 	

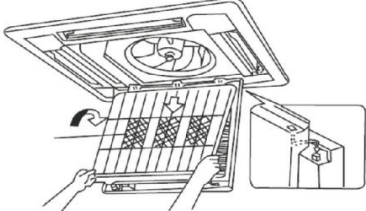
<p>b. Do not dry over fire.</p> <p>c. Do not run the air condition without the air filter.</p> <p>d. The suction grille must be opened by skilled personnel.</p>	
<p>Fix the air filters</p> <p>① Fix three air-cleaner on the air filter and then fix the air filter to the suction grille by hanging it to the projected portion above suction grille.</p> <p>② Set air filter by sliding the knob on the back of the suction grille inward.</p>	
<p>Shut the suction grille.</p>	<p>Refer to step.1</p>

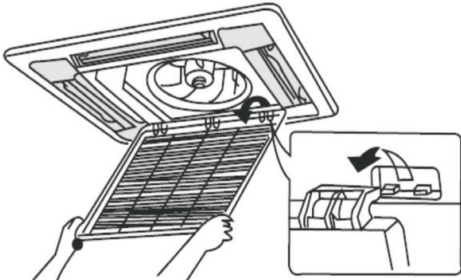
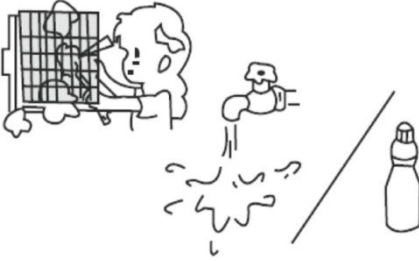
How to clean to the suction grille	
<p>① Open the suction grille</p>	<p>See step 1 of "How to clean the air filter".</p>
<p>② Remove the air filters</p>	<p>See step 2 of "How to clean the air filter".</p>
<p>③ Remove the suction grille</p> <p>Open the suction grille at 45°and then lift.</p>	
<p>④ Wash with water.</p> <p>When the suction grille is very dirty, use soft brush and neutral detergent. Shake water and dry in a shady place.</p>	
<p>⑤ Fix the suction grille.</p>	<p>Refer to step 3.</p>
<p>⑥ Fix air filter.</p>	<p>See step 4 of "How to clean the air filter".</p>
<p>⑦ Close the suction grille.</p>	<p>Refer to step 1.</p>

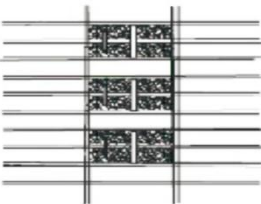
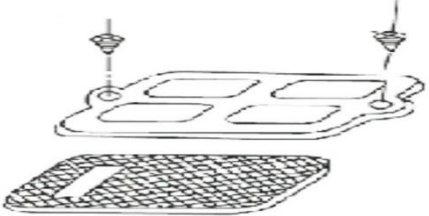
Changing air cleaner	
① Open the suction grille	See step 1 of "How to clean the air filter"
② Remove the air cleaner Remove the air filter and remove the air cleaner after unscrewing.	
③ Take off packing bag and put in new static electricity fiber filter, then fix them on the air filter.	
④ Fix the air filter	See step 4 of "How to clean the air filter"
Air cleaner functions and service cycle time.	
<p>Absorbs bad smell in air such as carbon monoxide carbon dioxide, benzyl, gasoline and so on.</p> <p>Absorbs harmful objects bigger than 1.0 um in air such as dust, germ, virus and so on.</p> <p>It can be used for about half a year to one year.</p>	

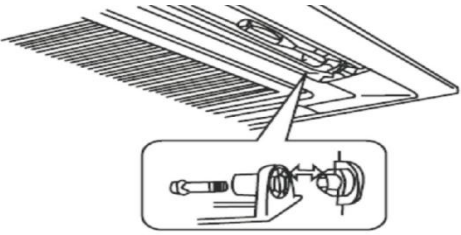
<p>How to clean the air outer and case.</p> <p>Clean with soft cloth or use water and neutral detergent.</p> <p>Do not use gasoline, benzene, thinner, polishing powder, liquid insecticide, which may cause discoloring or warping.</p> <p>If the air flow flap is very dirty, you may remove it to clean as shown below.</p>	
Detach and fix the flap.	
① Detach the flap Loosen the screws on the sides of the flap clean with soft cloth.	
② Fix the flap Set the ribs on the sides of the air outlet to the slit of the flap and then screw together to fix the flap.	

Before starting the air conditioner for the first time in the season.

- ① Check to make sure no objects obstructing the intake and outlets parts on both the indoor and outdoor units.
- ② Check to make sure ground wire is connected and that is not damaged.
- ③ Check to make sure air filter has been cleaned.
- ④ Turn on the power 6 hours before starting the air conditioner.

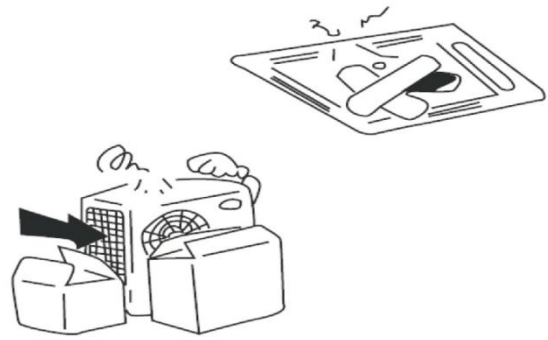

End of season cleaning

- ① Clean the filter and the body of the unit.
- ② Turn off power.
- ③ Clear outdoor of dust.
- ④ If there is any rust in the outdoor unit, this should be painted over to prevent the rust from spreading.

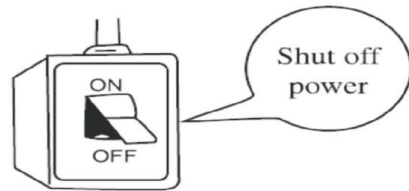

3. WIRING DIAGRAM

Model:FP-51XD/A-K;FP-68XD/A-K

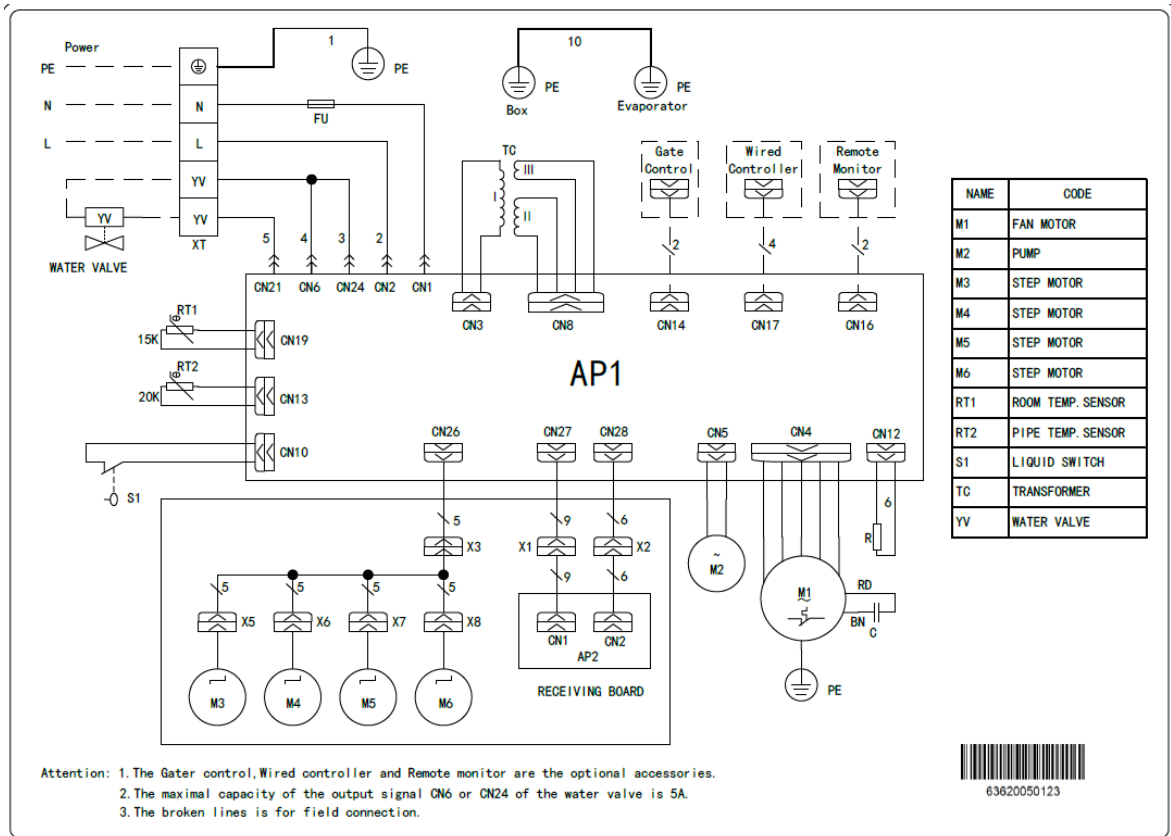

Model:FP-85XD/B-T;FP-102XD/B-T;FP-125XD/B-T;FP-140XD/B-T;FP-160XD/B-T;FP-180XD/B-T;FP-2

00XD/B-T;FP-85XD/B-T(E);FP-102XD/B-T(E);FP-125XD/B-T(E);FP-140XD/B-T(E);FP-160XD/B-T(E);FP-180XD/B-T(E)

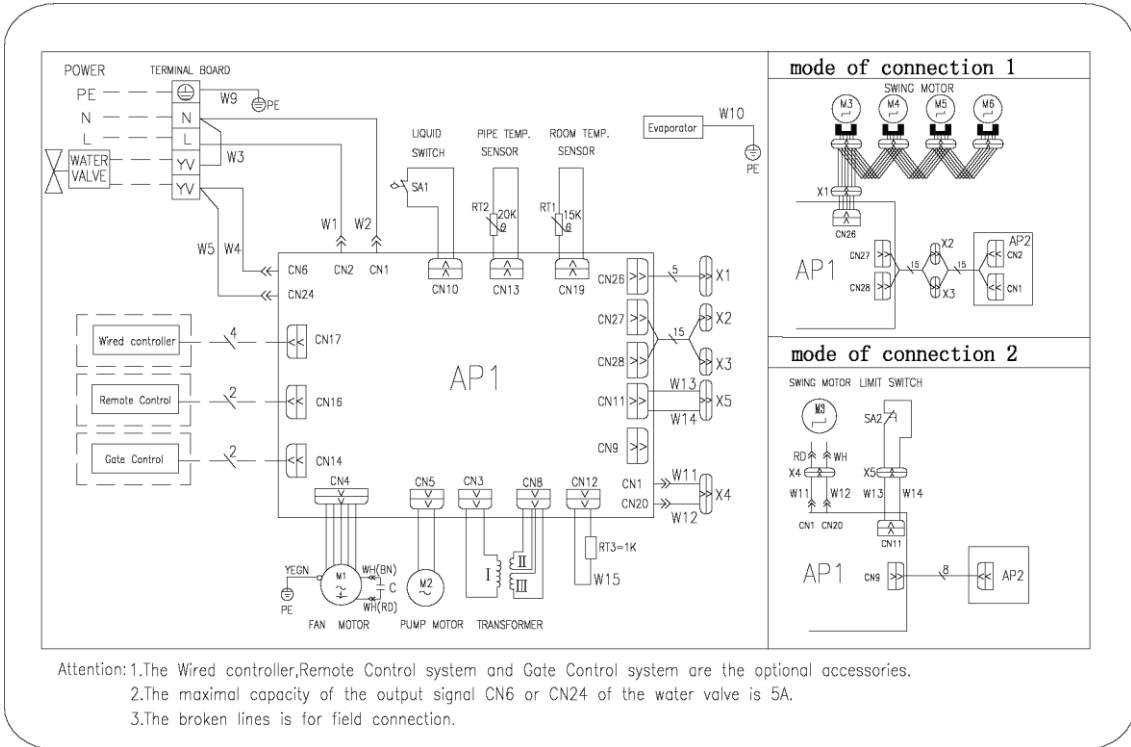

Model:FP-68XDT/B-K; FP-85XDT/B-K; FP-125XDT/B-K; FP-180XDT/B-K.; FP-68XDT/B-K(E); FP-85XDT/B-K(E); FP-125XDT/B-K(E); FP-180XDT/B-K(E).

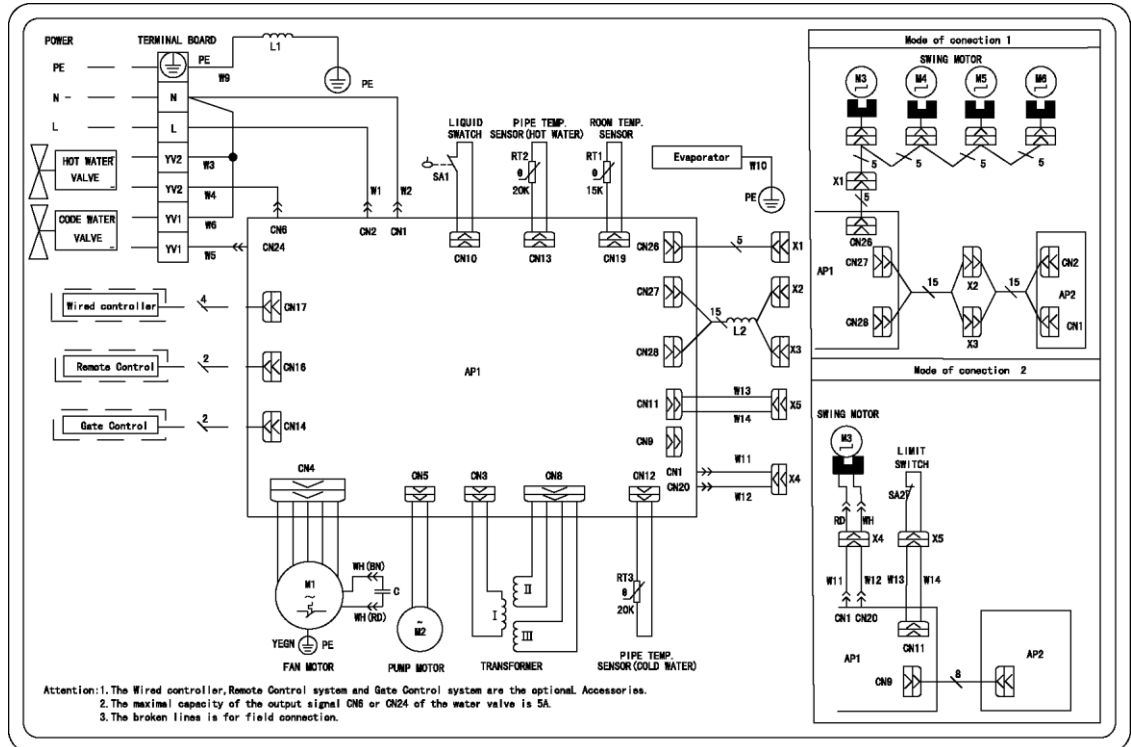

4. DISASSEMBLY AND ASSEMBLY PROCEDURE OF MAIN PARTS

Model: FP-85XD/B-T; FP-102XD/B-T; FP-125XD/B-T; FP-140XD/B-T; FP-160XD/B-T; FP-180XD/B-T; FP-200XD/B-T; FP-85XD/B-T; FP-102XD/B-T; FP-125XD/B-T; FP-140XD/B-T; FP-160XD/B-T; FP-180XD/B-T; FP-200XD/B-T; FP-68XDT/B-K; FP-85XDT/B-K; FP-125XDT/B-K; FP-180XDT/B-K. FP-51XD/A-K ,FP-68XD/A-K,FP-68XDT/B-K(E),FP-85XDT/B-K(E),FP-125XDT/B-K(E),FP-180XDT/B-K (E),FP-85XD/B-T(E),FP-102XD/B-T(E),FP-125XD/B-T(E),FP-140XD/B-T(E),FP-160XD/B-T(E),FP-180XD/B-T(E),FP-200XD/D-K(E).

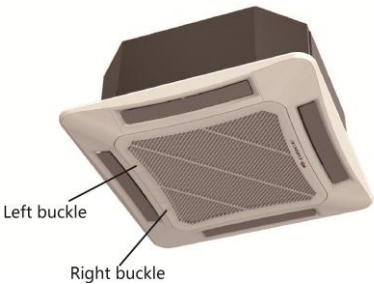
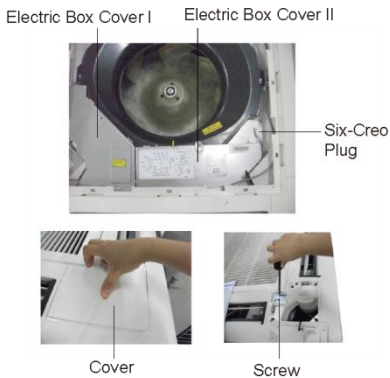
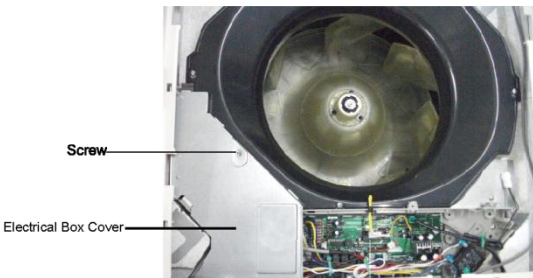
Disassembly Procedures of Indoor Unit (Panel TB03)		
Remark: Make sure that the unit is stopped running and power supply is cut off before removal of the motor.		
Process	Pictorial View	Handling Description
① Disassemble the grille of the front panel		Push the left and right buckles on the grille of the front panel toward the center and meanwhile pull it upward until it forms a 45° angle, after that pull the grille backward.
② Disassemble the front panel.		Disconnect the power cord of the fan motor and the plug of the limit switch. Open the cover II of the electric box and disconnect the six-core plug, then remove covers on four corners away, after that, loosen the screws to the right position and turn the front panel counter clockwise and lastly pull it out upward.
③ Disassemble the drain pan.		Loosen the screws on the cover I of the electrical box and then open the cover.

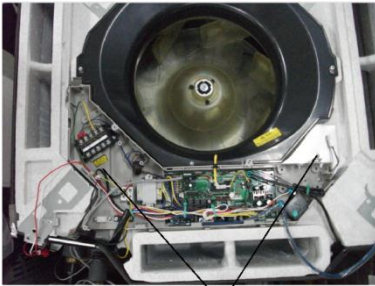
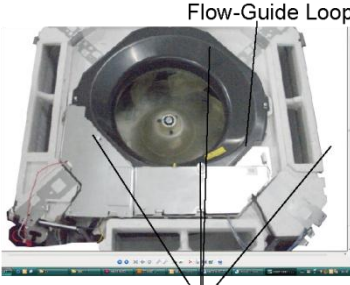
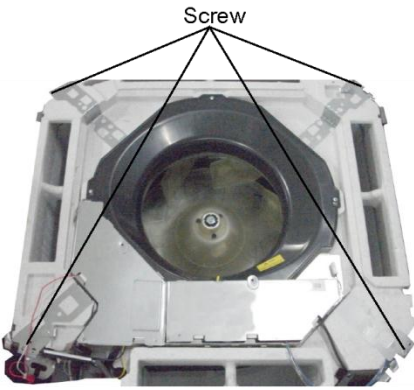
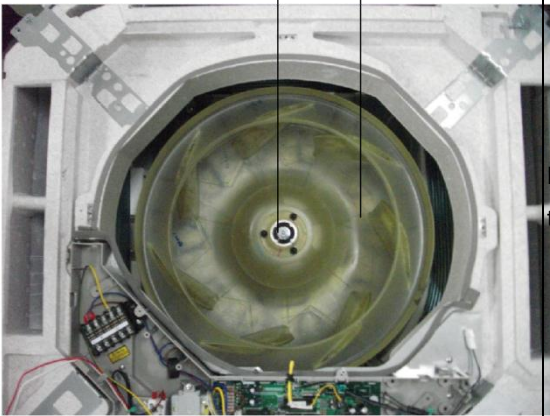
<p>④ Disassemble the electrical box</p>	 <p>Screw</p>	<p>Loosen two screws fixing the electric box and then disconnect each wiring terminals, after that take the electric box out upward.</p>
<p>⑤ Disassemble the flow-guide loop</p>	 <p>Flow-Guide Loop</p> <p>Screw</p>	<p>Loosen the screws fixing the flow-guide loop and then turn it counter clockwise.</p>
<p>⑥ Disassemble the drain pan</p>	 <p>Screw</p>	<p>Loose the screws on the drain pan and take it out upward.</p>
<p>⑦ Disassemble the fan blade</p>	 <p>Nut with Washer</p> <p>Fan Blade</p>	<p>Loosen the screws on the fan blade and then take it out upward.</p>

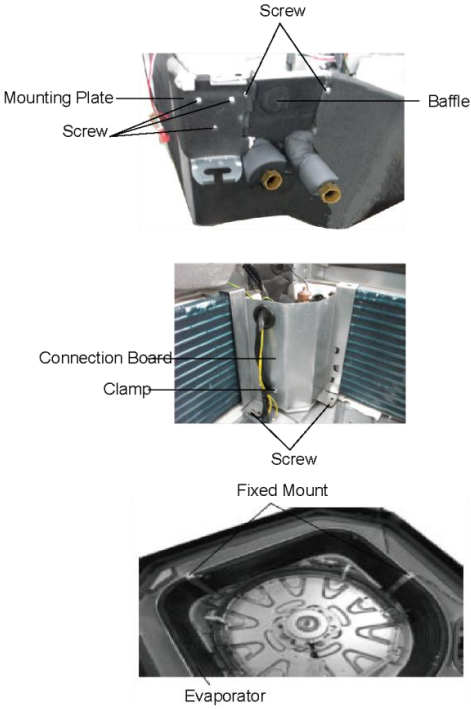
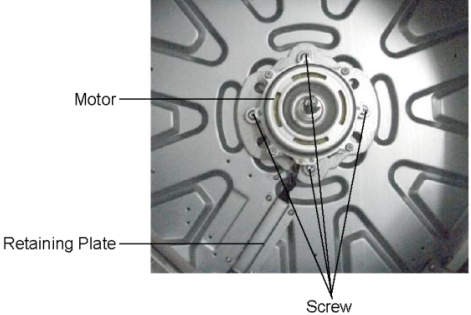
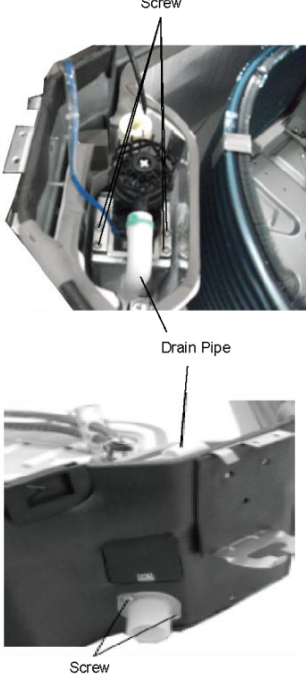
<p>⑧ Disassemble the evaporator</p>	 <p>Screw</p> <p>Mounting Plate</p> <p>Screw</p> <p>Baffle</p> <p>Connection Board</p> <p>Clamp</p> <p>Screw</p> <p>Fixed Mount</p> <p>Evaporator</p>	<p>Loosen the screws on the mounting plate and take it out.</p> <p>Loosen the screws on the baffle of the pipe outlet, and then press it downward to pull out the buckles on both side, after that, take the baffle away.</p> <p>Loosen the screws and clamps on the connection board of the evaporator, disconnect the earth lead, and then take the power cord of the motor, electric heater and earth lead out through the wire-cross hole, after that loosen the screws on the fixed mount and remove it away, finally take the evaporator out upward.</p>
<p>⑨ Disassemble the motor</p>	 <p>Motor</p> <p>Retaining Plate</p> <p>Screw</p>	<p>Loosen the screws on the retaining plate and the screw bolts on the motor, after that, take the motor out.</p>
<p>⑩ Disassemble the water pump and the drain pipe</p>	 <p>Screw</p> <p>Drain Pipe</p> <p>Screw</p>	<p>Loosen four screws fixing the water pump, disconnect the water pipe of the pump, take the mounting bracket away, then loosen these two screws fixing the water pipe, after that, take the water pipe away.</p>

5. EXPLODED VIEWS AND SPARE PART LISTS

FP-51XD/A-K; FP-68XD/A-K exploded views and spare parts list.

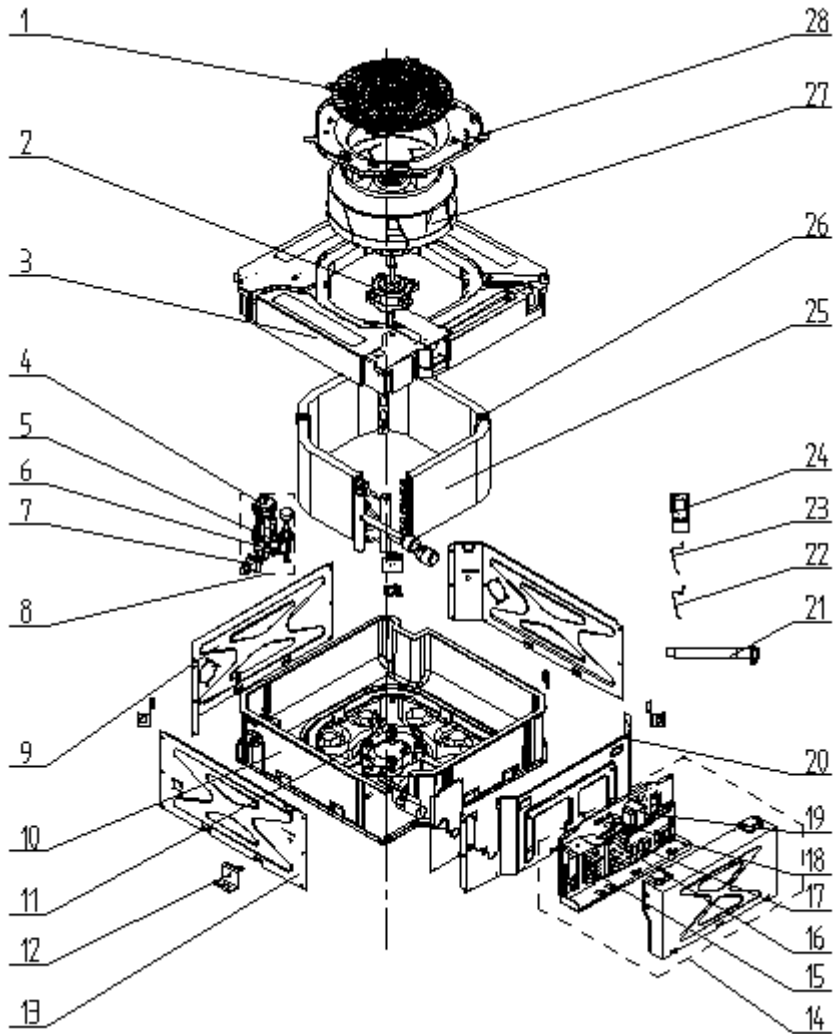

NO.	Discription	FP-51XD/A-K	FP-68XD/A-K	Quantity
		EM52000010	EM52000020	
	Name of Parts	Part Code	Part Code	
1	Rear Grill	26909400007	26909400007	1
2	Fan Motor	150101000011	150101000011	1
3	Water Tray Assy	01289400004	01289400004	1
4	Water Pump	43138220	43138220	1
5	Supporter	01809400067	01809400067	1
6	Liquid Level Switch	450102013	450102013	1
7	Pump Drainpipe	04269400001	04269400001	1
8	Water Pump Assy	15406002333	15406002333	1

Unit MAINTENANCE

9	Right Side Plate Sub-Assy	01319400013	01319400013	2
10	Foam Sub- Assy	000010000001	000010000001	1
11	Base Plate Assy	02229400007	02229400007	1
12	Body Installing Support	01332705	01332705	4
13	Left Side Plate Sub-Assy	01319400012	01319400012	1
14	Electric Box Assy	01396001501	01396001502	1
15	Terminal Board	420001000004	420001000004	1
16	Breadboard Holder	26909407	26909407	1
17	Main Board	30224000089	30224000089	1
18	Capacitor CBB61S	3301074702	3301074702	1
19	Transformer	4311022602	4311022602	1
20	Front Side Plate Sub-Assy	01319400014	01319400014	1
21	Drain Hose Sub-Assy	007008000001	007008000001	1
22	Room Sensor	39000191	39000191	1
23	Temperature Sensor	390001982	390001982	1
24	Remote Controller	30510516	30510516	1
25	Surface-Cooler Assy	01126000752	01126000752	1
26	Supporter(Evaporator)	01809400007	01809400007	3
27	Centrifugal Fan	10429400001	10429400001	1
28	Diversion Circle	10479400001	10479400001	1

Above data is subject to change without notice,pls refer the SP in global service website.

FP-85XD/B-T;FP-102XD/B-T;FP-125XD/B-T;FP-140XD/B-T;FP-160XD/B-T;FP-180XD/B-T;FP-200XD/B-T;FP-68XDT/B-K(E);FP-85XDT/B-K(E);FP-125XDT/B-K(E);FP-180XDT/B-K(E);FP-85XD/B-T(E);FP-102XD/B-T(E);FP-125XD/B-T(E);FP-140XD/B-T(E);FP-160XD/B-T(E);FP-180XD/B-T(E);FP-200XD/D-K(E) exploded views and spare parts list.

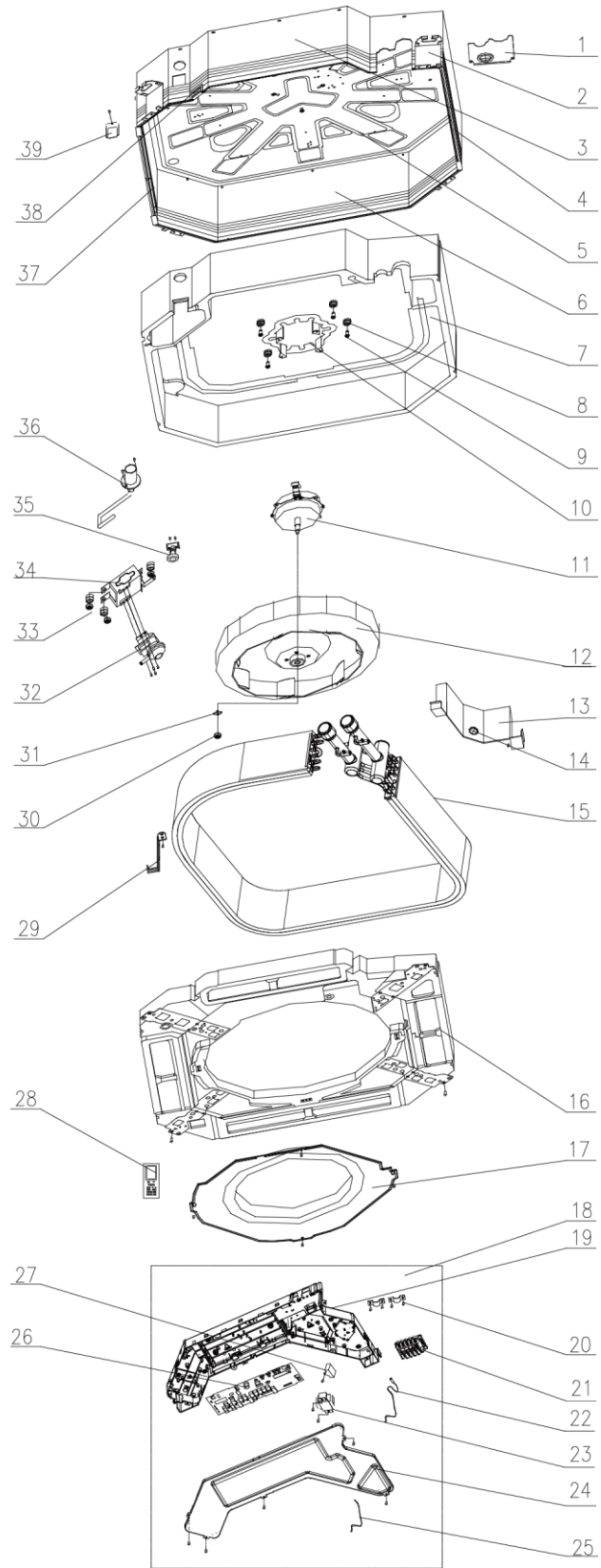

Unit MAINTENANCE

NO.	Discription	FP-85XD/B-T	FP-102XD/B-T	FP-85XD/B-T(E)	FP-102XD/B-T(E)	Quantity
		EM520N0930/EM520N0940	EM520N0910/EM520N0920	EM520N1300	EM520N1310	
	Name of Parts	Part Code	Part Code	Part Code	Part Code	
1	Tube-exit Plate	/	/	/	/	/
2	Body Fixing Plate	1332701	1332701	1332701	1332701	4
3	Front Side Plate	1302717	1302717	1302717	1302717	1
4	Left Side Plate	1302740	1302740	1302740	1302740	1
5	Base Plate	1222701	1222701	1222701	1222701	1
6	Rear Side Plate	1302719	1302719	1302719	1302719	1
7	Bottom Foam	52012720	52012720	52012720	52012720	1
8	Motor Gasket	76712711	76712711	76712711	76712711	4
9	Bolt	70210051	70210051	70210051	70210051	4
10	Motor Support	1702701	1702701	1702701	1702701	1
11	Motor	1570490101	1570490101	1570490101	1570490101	1
12	Centifugal Fan	10312721	10312721	10312721	10312721	1
13	Evap Connection	1072004	1072004	1072004	1072004	1
14	Cable-cross Loop	76515202	76515202	76515202	76515202	1
15	Heat exchanger	1126000042	1126000042	1126000042	1126000042	1
16	Water Tray	20182701	20182701	20182701	20182701	1
17	Flow-guide Loop	10372722	10372722	10372722	10372722	1
18	Electric Box asm	01396000021	01396000019	01396000021	01396000019	1
19	Electric Box	01424100049	01424100049	01424100049	01424100049	1
20	Wire Clamp	71010102	71010102	71010102	71010102	2
21	Terminal Board	420001000004	420001000004	420001000004	420001000004	1
22	Tube sensor	390001982	390001982	390001982	390001982	1
23	Transformer	4311022602	4311022602	4311022602	4311022602	1
24	Electric Box Cover	0142410004801A	0142410004801A	0142410004801A	0142410004801A	1

Unit MAINTENANCE

25	Room sensor	390000453	390000453	390000453	390000453	1
26	Main PCB	30224000089	30224000089	30224000089	30224000089	1
27	Capacitor	3301074702	3301074705	3301074702	3301074705	1
28	Remote Controller	30510516	30510516	30510516	30510516	1
29	Evap Support	1072003	1072003	1072003	1072003	2
30	Nut with Washer	70310012	70310012	70310012	70310012	3
31	Fixer	10312701	10312701	10312701	10312701	1
32	Water Pump	43130324	43130324	43130324	43130324	1
33	Pump Gasket	76712702	76712702	76712702	76712702	3
34	Pump Support	1332001	1332001	1332001	1332001	1
35	Water Level Switch	45018012	45018012	45018012	45018012	1
36	Pump Drainpipe	5232721	5232721	5232721	5232721	1
37	Right Side Plate	1302710	1302710	1302710	1302710	1
38	Cable-cross Block	76512702	76512702	76512702	76512702	1
39	Pump Cover Board	1252712	1252712	1252712	1252712	1

Above data is subject to change without notice,pls refer the SP in global service website.

NO.	Discription	FP-68XDT/B-K(E)	FP-85XDT/B-K(E)	Quantity
		EM520N1260	EM520N1270	
		Part Code	Part Code	
1	Tube-exit Plate	/	/	/
2	Body Fixing Plate	1332701	1332701	4
3	Front Side Plate	1302717	1302717	1
4	Left Side Plate	1302740	1302740	1
5	Base Plate	1222701	1222701	1
6	Rear Side Plate	1302719	1302719	1
7	Bottom Foam	52012720	52012720	1
8	Motor Gasket	76712711	76712711	4
9	Bolt	70210051	70210051	4
10	Motor Support	1702701	1702701	1

Unit MAINTENANCE

11	Motor	1570490101	1570490101	1
12	Centifugal Fan	10312721	10312721	1
13	Evap Connection	1072004	1072004	1
14	Cable-cross Loop	76515202	76515202	1
15	Heat exchanger	1126000042	1126000042	1
16	Water Tray	20182701	20182701	1
17	Flow-guide Loop	10372722	10372722	1
18	Electric Box asm	01396000867	01396000868	1
19	Electric Box	01424100049	01424100049	1
20	Wire Clamp	71010102	71010102	2
21	Terminal Board	422000000010	422000000010	1
22	Tube sensor	390001982	390001982	1
23	Transformer	4311022602	4311022602	1
24	Electric Box Cover	0142410004801A	0142410004801A	1
25	Room sensor	390000453	390000453	1
26	Main PCB	30224000089	30224000089	1
27	Capacitor	3301074702	3301074704	1
28	Remote Controller	30510516	30510516	1
29	Evap Support	1072003	1072003	2
30	Nut with Washer	70310012	70310012	3
31	Fixer	10312701	10312701	1
32	Water Pump	43130324	43130324	1
33	Pump Gasket	76712702	76712702	3
34	Pump Support	1332001	1332001	1
35	Water Level Switch	45018012	45018012	1
36	Pump Drainpipe	5232721	5232721	1
37	Right Side Plate	1302710	1302710	1
38	Cable-cross Block	76512702	76512702	1
39	Pump Cover Board	1252712	1252712	1

Above data is subject to change without notice,pls refer the SP in global service website.

Unit MAINTENANCE

NO	Discription	FP-125XD/B-T	FP-140XD/B-T	FP-160XD/B-T	Quantity
		EM520N0890/EM520N0900	EM520N0870EM520N0880	EM520N0850/EM520N0860	
	Name of Parts	Part Code	Part Code	Part Code	
1	Tube-exit Plate	02206000001	02206000001	02206000001	1
2	Body Fixing Plate	01332701	01332701	01332701	4
3	Front Side Plate	01302718	01302718	01302718	1
4	Left Side Plate	01302715	01302715	01302715	1
5	Base Plate	52012722	52012722	52012722	1
6	Rear Side Plate	01302714	01302714	01302714	1
7	Bottom Foam	52012722	52012722	52012722	1
8	Motor Gasket	76712711	76712711	76712711	4
9	Bolt	70210051	70210051	70210051	4
10	Motor Support	01702701	01702701	01702701	1
11	Motor	1570410203	1570410203	1570410203	1
12	Centifugal Fan	10312705	10312705	10312705	1
13	Evap Connection	01072710	01072710	01072710	1
14	Cable-cross Loop	76515202	76515202	76515202	1
15	Heat exchanger	01126000030	01126000030	01126000044	1
16	Water Tray	20182701	20182701	20182701	1
17	Flow-guide Loop	10372722	10372722	10372722	1
18	Electric Box asm	01396000914	01396000030	01396000887	1
19	Electric Box	01424100049	01424100049	01424100049	1
20	Wire Clamp	71010102	71010102	71010102	2
21	Terminal Board	420001000004	420001000004	420001000004	1
22	Tube sensor	390001982	390001982	390001982	1
23	Transformer	4311022602	4311022602	4311022602	1
24	Electric Box Cover	0142410004801A	0142410004801A	0142410004801A	1
25	Room sensor	390000453	390000453	390000453	1
26	Main PCB	30224000089	30224000089	30224000089	1
27	Capacitor	3301074704	3301074711	3301074707	1
28	Remote	30510516	30510516	30510516	1

Unit MAINTENANCE

	Controller				
29	Evap Support	01072715	01072715	01072715	2
30	Nut with Washer	70310012	70310012	70310012	1
31	Fixer	10312701	10312701	10312701	1
32	Water Pump	43130324	43130324	43130324	1
33	Pump Gasket	76712702	76712702	76712702	3
34	Pump Support	01329416	01329416	01329416	1
35	Water Level Switch	45018012	45018012	45018012	1
36	Pump Drainpipe	05230026	05230026	05230026	1
37	Right Side Plate	01302716	01302716	01302716	1
38	Cable-cross Block	76512702	76512702	76512702	1
39	Pump Cover Board	01252713	01252713	01252713	1

Above data is subject to change without notice,pls refer the SP in global service website.

NO	Discription	FP-125XD/B-T(E)	FP-140XD/B-T(E)	FP-160XD/B-T(E)	FP-125XDT/B-K(E)	Quantity
		EM520N1320	EM520N1330	EM520N1340	EM520N1280	
	Name of Parts	Part Code	Part Code	Part Code	Part Code	
1	Tube-exit Plate	02206000001	02206000001	02206000001	02206000001	1
2	Body Fixing Plate	01332701	01332701	01332701	01332701	4
3	Front Side Plate	01302718	01302718	01302718	01302718	1
4	Left Side Plate	01302715	01302715	01302715	01302715	1
5	Base Plate	52012722	52012722	52012722	52012722	1
6	Rear Side Plate	01302714	01302714	01302714	01302714	1
7	Bottom Foam	52012722	52012722	52012722	52012722	1
8	Motor Gasket	76712711	76712711	76712711	76712711	4
9	Bolt	70210051	70210051	70210051	70210051	4
10	Motor Support	01702701	01702701	01702701	01702701	1
11	Motor	15704102	1570410202	1570410202	15704102	1
12	Centifugal Fan	10312705	10312705	10312705	10312705	1
13	Evap Connection	01072710	01072710	01072710	01072710	1

Unit MAINTENANCE

14	Cable-cross Loop	76515202	76515202	76515202	76515202	1
15	Heat exchanger	01126000030	01126000030	01126000044	01126000030	1
16	Water Tray	20182701	20182701	20182701	20182701	1
17	Flow-guide Loop	10372722	10372722	10372722	10372722	1
18	Electric Box asm	01396000914	01396000025	01396000729	01396000019	1
19	Electric Box	01424100049	01424100049	01424100049	01424100049	1
20	Wire Clamp	71010102	71010102	71010102	71010102	2
21	Terminal Board	420001000004	420001000004	420001000004	420001000004	1
22	Tube sensor	390001982	390001982	390001982	390001982	1
23	Transformer	4311022602	4311022602	4311022602	4311022602	1
24	Electric Box Cover	0142410004801A	0142410004801A	0142410004801A	0142410004801A	1
25	Room sensor	390000453	390000453	390000453	390000453	1
26	Main PCB	30224000089	30224000089	30224000089	30224000089	1
27	Capacitor	3301074702	3301074714	3301074706	3301074714	1
28	Remote Controller	30510516	30510516	30510516	30510516	1
29	Evap Support	01072715	01072715	01072715	01072715	2
30	Nut with Washer	70310012	70310012	70310012	70310012	1
31	Fixer	10312701	10312701	10312701	10312701	1
32	Water Pump	43130324	43130324	43130324	43130324	1
33	Pump Gasket	76712702	76712702	76712702	76712702	3
34	Pump Support	01329416	01329416	01329416	01329416	1
35	Water Level Switch	45018012	45018012	45018012	45018012	1
36	Pump Drainpipe	05230026	05230026	05230026	05230026	1
37	Right Side Plate	01302716	01302716	01302716	01302716	1
38	Cable-cross Block	76512702	76512702	76512702	76512702	1
39	Pump Cover Board	01252713	01252713	01252713	01252713	1

Above data is subject to change without notice,pls refer the SP in global service website.

Unit MAINTENANCE

NO.	Discription	FP-180XD/B-T	FP-200XD/B-T	Quantity
		EM520N0830/EM520N0840	EM520N0810/EM520N0820	
	Name of Parts	Part Code	Part Code	
1	Tube-exit Plate	02206000001	02206000001	1
2	Body Fixing Plate	01332701	01332701	4
3	Front Side Plate	01302713	01302713	1
4	Left Side Plate	01302711	01302711	1
5	Base Plate	01222701	01222701	1
6	Rear Side Plate	01302709	01302709	1
7	Bottom Foam	52012721	52012721	1
8	Motor Gasket	76712711	76712711	4
9	Bolt	70210051	70210051	4
10	Motor Support	01702701	01702701	1
11	Motor	1570490301	15704903	1
12	Centifugal Fan	26904115	26904115	1
13	Evap Connection	01072733	01072733	1
14	Cable-cross Loop	76515202	76515202	1
15	Heat exchanger	01126000043	01126000043	1
16	Water Tray	20182701	20182701	1
17	Flow-guide Loop	10372722	10372722	1
18	Electric Box asm	01396000019	01396000025	1
19	Electric Box	01424100049	01424100049	1
20	Wire Clamp	71010102	71010102	2
21	Terminal Board	420001000004	420001000004	1
22	Tube Sensor	390001982	390001982	1
23	Transformer	4311022602	4311022602	1
24	Electric Box Cover	0142410004801A	0142410004801A	1
25	Room sensor	390000453	390000453	1
26	Main PCB	30224000089	30224000089	1
27	Capacitor	3301074705	3301074711	1
28	Remote Controller	30510516	30510516	1
29	Evap Support	01072708	01072708	2

Unit MAINTENANCE

30	Nut with Washer	70310012	70310012	1
31	Fixer	10312701	10312701	1
32	Water Pump	43130324	43130324	1
33	Pump Gasket	76712702	76712702	3
34	Pump Support	01332721	01332721	1
35	Water Level Switch	45018012	45018012	1
36	Pump Drainpipe	05230026	05230026	1
37	Right Side Plate	01302712	01302712	1
38	Cable-cross Block	76512702	76512702	1
39	Pump Cover Board	01252713	01252713	1

Above data is subject to change without notice,pls refer the SP in global service website.

NO.	Discription Name of Parts	FP-180XD/B-T(E)	FP-200XD/D-K(E)	FP-180XDT/B-K(E)	Quantity
		EM520N1350	EM520N1360	EM520N1290	
		Part Code	Part Code	Part Code	
1	Tube-exit Plate	02206000001	02206000001	02206000001	1
2	Body Fixing Plate	01332701	01332701	01332701	4
3	Front Side Plate	01302713	01302713	01302713	1
4	Left Side Plate	01302711	01302711	01302711	1
5	Base Plate	01222701	01222701	01222701	1
6	Rear Side Plate	01302709	01302709	01302709	1
7	Bottom Foam	52012721	52012721	52012721	1
8	Motor Gasket	76712711	76712711	76712711	4
9	Bolt	70210051	70210051	70210051	4
10	Motor Support	01702701	01702701	01702701	1
11	Motor	1570490301	1570940000301	1570490301	1
12	Centifugal Fan	26904115	26904115	26904115	1
13	Evap Connection	01072733	01072733	01072733	1
14	Cable-cross Loop	76515202	76515202	76515202	1
15	Heat exchanger	01126000043	01126000043	01126000043	1
16	Water Tray	20182701	20182701	20182701	1
17	Flow-guide Loop	10372722	10372722	10372722	1

Unit MAINTENANCE

18	Electric Box asm	01396000019	01396001567	01396000870	1
19	Electric Box	01424100049	01424100049	01424100049	1
20	Wire Clamp	71010102	71010102	71010102	2
21	Terminal Board	420001000004	420001000004	420001000004	1
22	Tube Sensor	390001982	390001982	390001982	1
23	Transformer	4311022602	4311022602	4311022602	1
24	Electric Box Cover	0142410004801A	0142410004801A	0142410004801A	1
25	Room sensor	390000453	390000453	390000453	1
26	Main PCB	30224000089	30224000089	30224000089	1
27	Capacitor	3301074705	3301074711	3301074706	1
28	Remote Controller	30510516	30510516	30510516	1
29	Evap Support	01072708	01072708	01072708	2
30	Nut with Washer	70310012	70310012	70310012	1
31	Fixer	10312701	10312701	10312701	1
32	Water Pump	43130324	43130324	43130324	1
33	Pump Gasket	76712702	76712702	76712702	3
34	Pump Support	01332721	01332721	01332721	1
35	Water Level Switch	45018012	45018012	45018012	1
36	Pump Drainpipe	05230026	05230026	05230026	1
37	Right Side Plate	01302712	01302712	01302712	1
38	Cable-cross Block	76512702	76512702	76512702	1
39	Pump Cover Board	01252713	01252713	01252713	1

Above data is subject to change without notice,pls refer the SP in global service website.

FP-68XDT/B-K; FP-68XDT/B-K(E) exploded views and spare parts list.

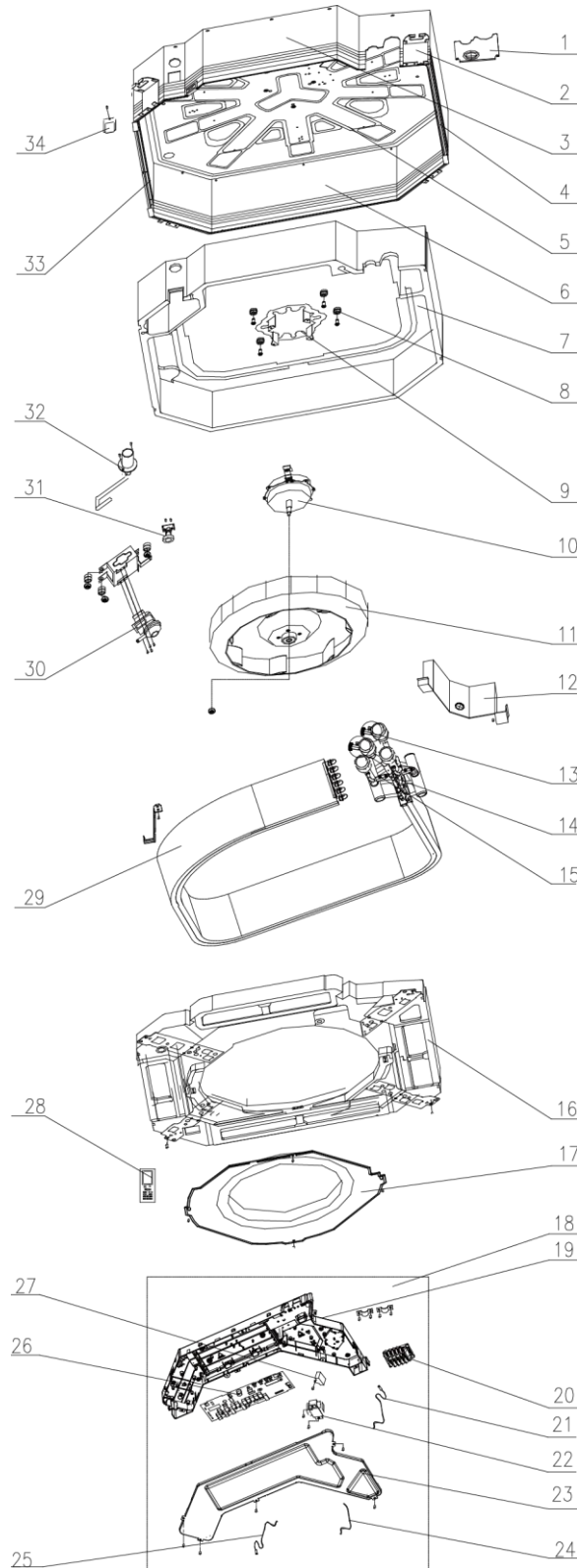

NO.	Discription	FP-68XDT/B-K	FP-68XDT/B-K(E)	Quantity
		EM520N0990	EM520N1260	
	Name of Parts	Part Code	Part Code	
1	Tube Exit Plate Assy	0134600095	0134600095	1

Unit MAINTENANCE

2	Body Fixing Plate	01332701	01332701	4
3	Front Side Plate	01302717	01302717	1
4	Left Side Plate	01302740	01302740	1
5	Base Plate	01222701	01222701	1
6	Rear Side Plate	01302719	01302719	1
7	Bottom Foam	52012720	52012720	1
8	Motor Gasket	76712711	76712711	4
9	Motor Support	01702701	01702701	1
10	Motor	1570490101	1570490101	1
11	Centifugal Fan	10312721	10312721	1
12	Evap Connection	01072004	01072004	1
13	Deflation Valve	07108206	07108206	2
14	Valve chest (air release valve)	07336000028	07336000028	2
15	Valve chest (air release valve)	0733600001501	0733600001501	2
16	Water Tray	20182701	20182701	1
17	Flow-guide Loop	0372701	0372701	1
18	Electric Box asm	01396000867	01396000867	1
19	Electric Box	01424100049	01424100049	1
20	Terminal Board	422000000010	422000000010	1
21	Tube sensor	390001982	390001982	1
22	Transformer	4311022602	4311022602	1
23	Electric Box Cover	0142410004801A	0142410004801A	1
24	Room sensor	390000453	390000453	1
25	Tube sensor	3900028807	3900028807	1
26	Main PCB	30224000089	30224000089	1
27	Capacitor	3301074702	3301074702	1
28	Remote Controller	30510516	30510516	1
29	Heat exchanger	01126000562	01126000562	1
30	Water Pump	43130324	43130324	1
31	Water Level Switch	45018012	45018012	1
32	Pump Drainpipe	05232721	05232721	1
33	Right Side Plate	01302710	01302710	1
34	Pump Cover Board	01252712	01252712	1

Above data is subject to change without notice,pls refer the SP in global service website.

FP-85XDT/B-K; FP-85XDT/B-K(E) exploded views and spare parts list.

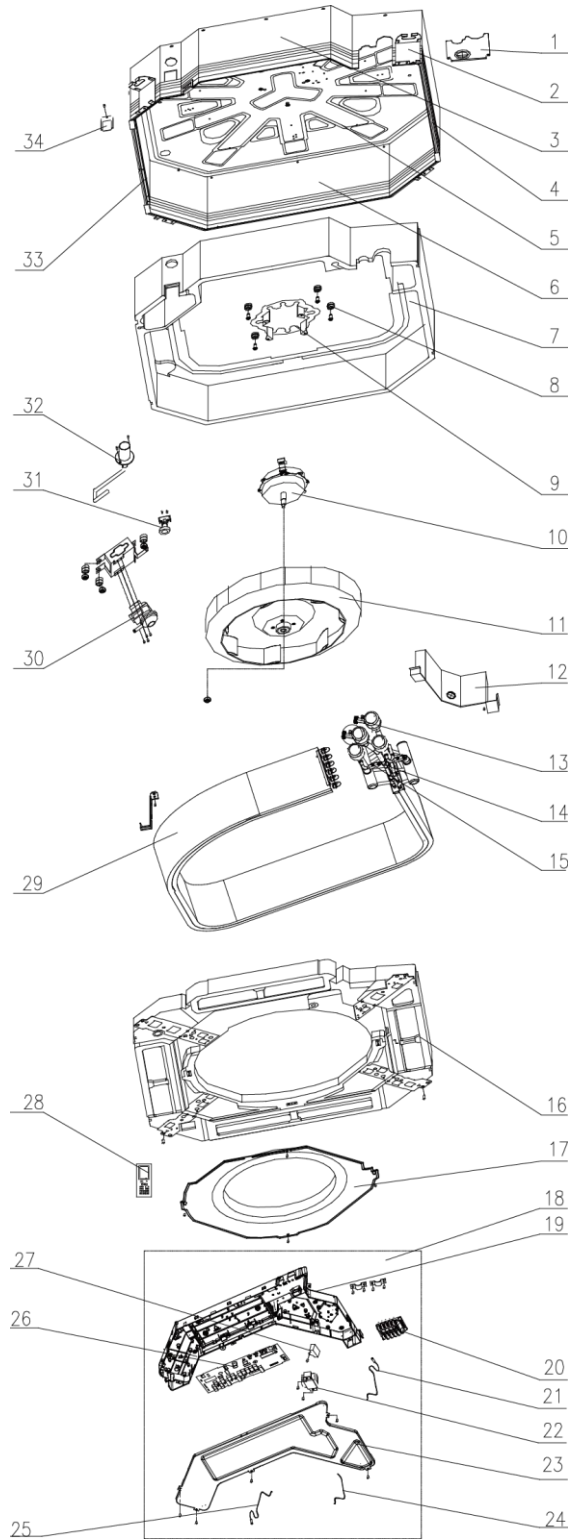

NO.	Discription	FP-85XDT/B-K	FP-85XDT/B-K(E)	Quantity
		EM520N0960	EM520N1270	
	Name of Parts	Part Code	Part Code	
1	Tube Exit Plate Assy	01346000095	01346000095	1
2	Body Fixing Plate	01332701	01332701	4

Unit MAINTENANCE

3	Front Side Plate	01302717	01302717	1
4	Left Side Plate	01302740	01302740	1
5	Base Plate	01222701	01222701	1
6	Rear Side Plate	01302719	01302719	1
7	Bottom Foam	52012720	52012720	1
8	Motor Gasket	76712711	76712711	4
9	Motor Support	01702701	01702701	1
10	Motor	1570490101	1570490101	1
11	Centifugal Fan	10312721	10312721	1
12	Evap Connection	01072004	01072004	1
13	Deflation Valve	07108206	07108206	2
14	Valve chest (air release valve)	07336000028	07336000028	2
15	Valve chest (air release valve)	0733600001501	0733600001501	2
16	Water Tray	20182701	20182701	1
17	Flow-guide Loop	0372701	0372701	1
18	Electric Box asm	1396000868	1396000868	1
19	Electric Box	01424100049	01424100049	1
20	Terminal Board	422000000010	422000000010	1
21	Tube sensor	390001982	390001982	1
22	Transformer	4311022602	4311022602	1
23	Electric Box Cover	0142410004801A	0142410004801A	1
24	Room sensor	390000453	390000453	1
25	Tube sensor	3900028807	3900028807	1
26	Main PCB	30224000089	30224000089	1
27	Capacitor	3301074704	3301074704	1
28	Remote Controller	30510516	30510516	1
29	Heat exchanger	01126000562	01126000562	1
30	Water Pump	43130324	43130324	1
31	Water Level Switch	45018012	45018012	1
32	Pump Drainpipe	05232721	05232721	1
33	Right Side Plate	01302710	01302710	1
34	Pump Cover Board	01252712	01252712	1

Above data is subject to change without notice,pls refer the SP in global service website.

FP-125XDT/B-K; FP-125XDT/B-K(E) exploded views and spare parts list.

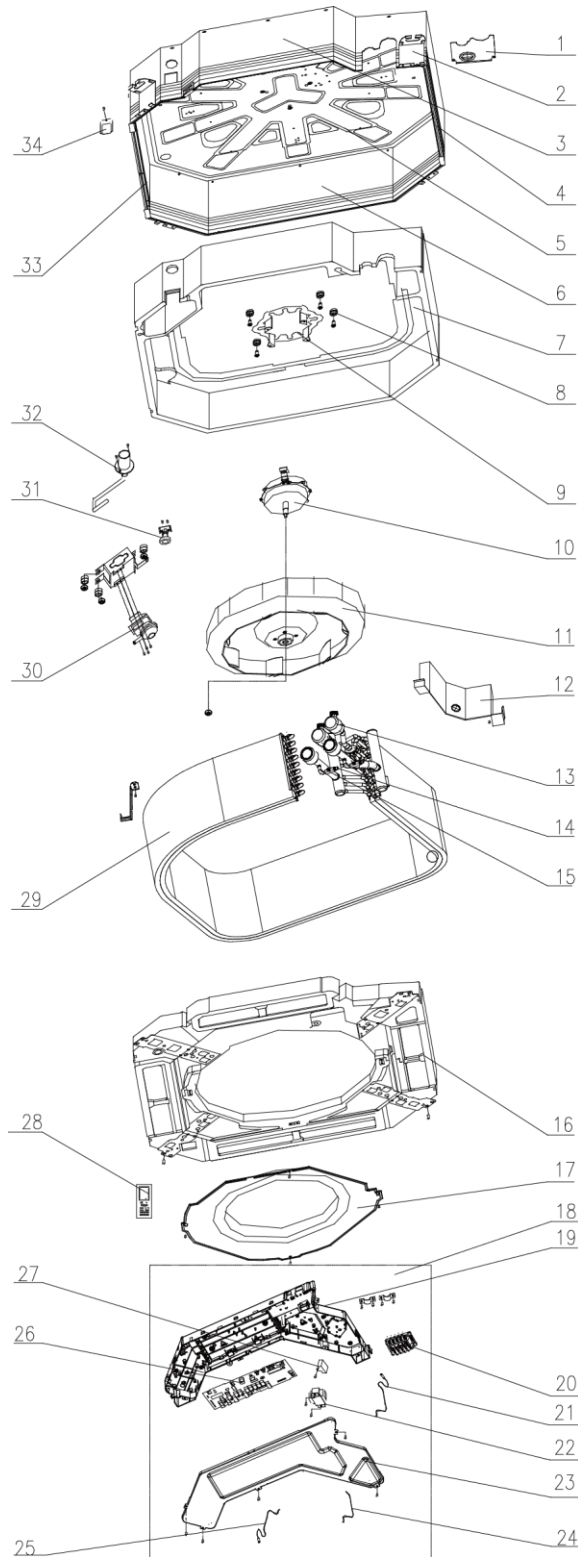

NO.	Discription	FP-125XDT/B-K	FP-125XDT/B-K(E)	Quantity
		EM520N0970	EM520N1280	
	Name of Parts	Part Code	Part Code	
1	Tube Exit Plate Assy	01346000094	01346000094	1

Unit MAINTENANCE

2	Body Fixing Plate	01332701	01332701	4
3	Front Side Plate	01302718	01302718	1
4	Left Side Plate	01302715	01302715	1
5	Base Plate	01222701	01222701	1
6	Rear Side Plate	01302714	01302714	1
7	Bottom Foam	52012722	52012722	1
8	Motor Gasket	76712711	76712711	4
9	Motor Support	01702701	01702701	1
10	Motor	15704102	15704102	1
11	Centifugal Fan	10312705	10312705	1
12	Evap Connection	01072710	01072710	1
13	Deflation Valve	07108206	07108206	2
14	Valve chest (air release valve)	07336000028	07336000028	2
15	Valve chest (air release valve)	0733600001501	0733600001501	2
16	Water Tray	20182701	20182701	1
17	Flow-guide Loop	10372722	10372722	1
18	Electric Box asm	01396000869	01396000869	1
19	Electric Box	01424100049	01424100049	1
20	Terminal Board	422000000010	422000000010	1
21	Tube sensor	390001982	390001982	1
22	Transformer	4311022602	4311022602	1
23	Electric Box Cover	0142410004801A	0142410004801A	1
24	Room sensor	390000453	390000453	1
25	Tube sensor	3900028807	3900028807	1
26	Main PCB	30224000089	30224000089	1
27	Capacitor	3301074714	3301074714	1
28	Remote Controller	30510516	30510516	1
29	Heat exchanger	01126000560	01126000560	1
30	Water Pump	43130324	43130324	1
31	Water Level Switch	45018012	45018012	1
32	Pump Drainpipe	05230026	05230026	1
33	Right Side Plate	01302716	01302716	1
34	Pump Cover Board	01252713	01252713	1

Above data is subject to change without notice,pls refer the SP in global service website.

FP-180XDT/B-K; FP-180XDT/B-K(E) exploded views and spare parts list.

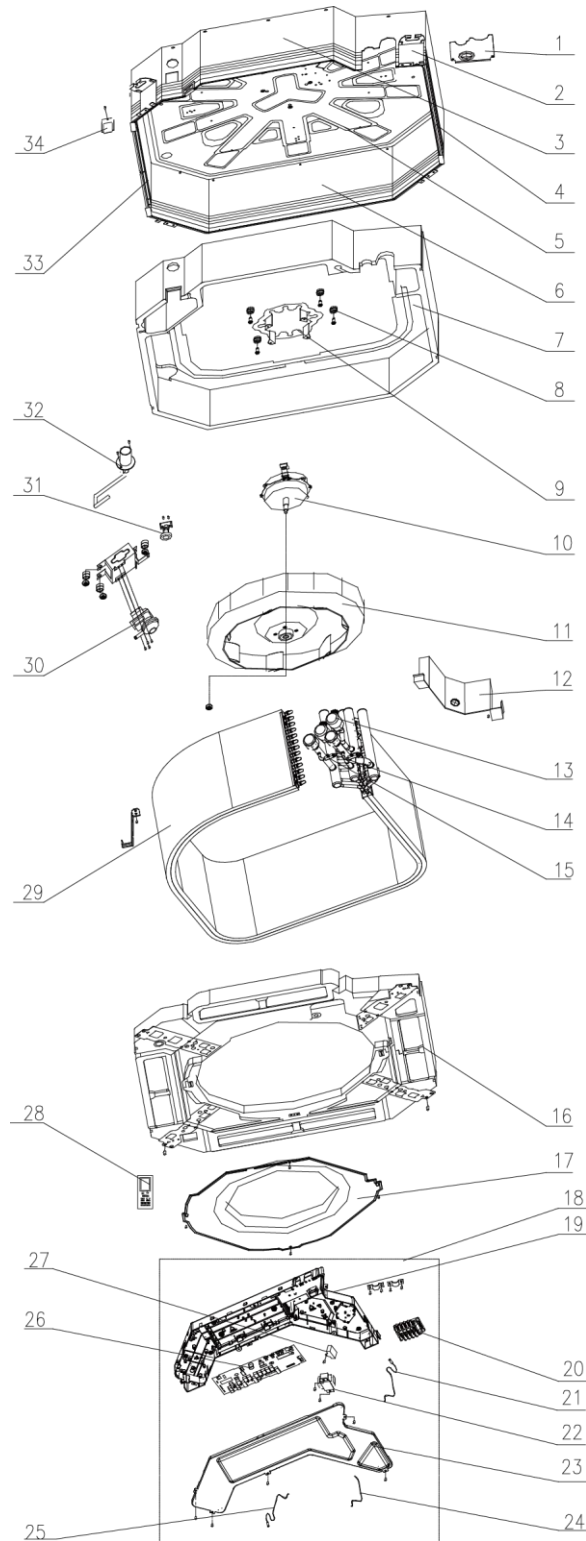

NO.	Discription	FP-180XDT/B-K	FP-180XDT/B-K(E)	Quantity
		EM520N0980	EM520N1290	
	Name of Parts	Part Code	Part Code	
1	Tube Exit Plate Assy	0134600094	0134600094	1
2	Body Fixing Plate	01332701	01332701	4

Unit MAINTENANCE

3	Front Side Plate	01302713	01302713	1
4	Left Side Plate	01302711	01302711	1
5	Base Plate	01222701	01222701	1
6	Rear Side Plate	01302709	01302709	1
7	Bottom Foam	52012721	52012721	1
8	Motor Gasket	76712711	76712711	4
9	Motor Support	01702701	01702701	1
10	Motor	1570490301	1570490301	1
11	Centifugal Fan	26904115	26904115	1
12	Evap Connection	01072733	01072733	1
13	Deflation Valve	07108206	07108206	2
14	Valve chest (air release valve)	07336000028	07336000028	2
15	Valve chest (air release valve)	0733600001501	0733600001501	2
16	Water Tray	20182701	20182701	1
17	Flow-guide Loop	10372722	10372722	1
18	Electric Box asm	01396000870	01396000870	1
19	Electric Box	01424100049	01424100049	1
20	Terminal Board	422000000010	422000000010	1
21	Tube sensor	390001982G	390001982G	1
22	Transformer	4311022602	4311022602	1
23	Electric Box Cover	0142410004801A	0142410004801A	1
24	Room sensor	390000453	390000453	1
25	Tube sensor	3900028807	3900028807	1
26	Main PCB	30224000089	30224000089	1
27	Capacitor	3301074706	3301074706	1
28	Remote Controller	30510516	30510516	1
29	Heat exchanger	01126000560	01126000560	1
30	Water Pump	43130324	43130324	1
31	Water Level Switch	45018012	45018012	1
32	Pump Drainpipe	05230026	05230026	1
33	Right Side Plate	01302712	01302712	1
34	Pump Cover Board	01252713	01252713	1

Above data is subject to change without notice,pls refer the SP in global service website.



GREE ELECTRIC APPLIANCES, INC. OF ZHUHAI

Add: West Jinji Rd, Qianshan, Zhuhai, Guangdong, China, 519070

Tel: (+86-756) 8522218 Fax: (+86-756) 8669426

E-mail: gree@gree.com.cn www.gree.com

For continuous improvement in the products, Gree reserves the right to modify the product specification and appearance in this manual without notice and without incurring any obligation.

No.: JF00300710