

CASSETTE TYPE FAN COIL UNIT

(GC201409)

GREE MAKING BETTER AIR CONDITIONERS GREE MAKING BETTER AIR CONDITIONERS GREE MAKING BETTER AIR CONDITIONERS GREE MAKING BETTER AIR CONDITIONERS GREE

TECHNICAL SALES GUIDE-50/60Hz
CAPACITY RANGE:850~2000m³/h
SUPER HIGH AMBIENT OPERATION TO 45 °C

GREE MAKING BETTER AIR CONDITIONERS GREE MAKING BETTER AIR CONDITIONERS GREE MAKING BETTER AIR CONDITIONERS GREE MAKING BETTER AIR CONDITIONERS GREE



GREE ELECTRIC APPLIANCES, INC. OF ZHUHAI

CONTENTS

- 1 MODEL LIST1
- 2 NOMENCLATURE2
- 3 FEATURES & BENEFITS2
- 5 DIMENSION.....3
- 4 INSTALLATION3
- 6 SPECIFICATION.....4
 - 7.1 Export sales for EU countries13
 - 7.2 Export sales for other countries13
- 7 PERFORMANCE RATING13
- 8 WIRING DIAGRAM14
- 9 OPERATION & CONTROLS15

1 MODEL LIST

Model name	Pipes type	Cooling/heating capacity (W)	Air flow volume (m ³ /h)	Power supply (V, Ph, Hz)	Remarks
FP-85XD/B-T	2 pipes	4150/5600	800	220-240V~ 50Hz	
		4160/7800	780	208-230V~ 60Hz	
FP-102XD/B-T		5000/6500	1020	220-240V~ 50Hz	
		5400/9000	1020	208-230V~ 60Hz	
FP-125XD/B-T		6000/7800	1180	220-240V~ 50Hz	
		6300/10000	1130	208-230V~ 60Hz	
FP-140XD/B-T		8000/9000	1400	220-240V~ 50Hz	
		8000/12000	1350	208-230V~ 60Hz	
FP-160XD/B-T		8700/10000	1550	220-240V~ 50Hz	
		9000/14000	1550	208-230V~ 60Hz	
FP-180XD/B-T		9500/11000	1800	220-240V~ 50Hz	
		10000/16000	1800	208-230V~ 60Hz	
FP-200XD/B-T		13000/14600	2000	220-240V~ 50Hz	
		13000/19000	2000	208-230V~ 60Hz	
FP-51XD/A-K		2750/3400	510	220-240V~ 50Hz	
FP-68XD/A-K		3300/3800	660		
FP-85XD/B-T(E)		4500/5400	800		
FP-102XD/B-T(E)		5000/6100	940		
FP-125XD/B-T(E)		6000/6900	1090		
FP-140XD/B-T(E)		7400/8400	1400		
FP-160XD/B-T(E)	8400/9000	1500			
FP-180XD/B-T(E)	9500/10500	1640			
FP-200XD/D-K(E)	11100/11700	1700			
FP-68XDT/B-K	4 pipes	3300/5800	680		
FP-85XDT/B-K		4100/6800	850		
FP-125XDT/B-K		6300/9500	1250		
FP-180XDT/B-K		9000/13500	1800		
FP-68XDT/B-K(E)		3500/5800	680		
FP-85XDT/B-K(E)		4500/6800	850		
FP-125XDT/B-K(E)		6000/9200	1250		
FP-180XDT/B-K(E)		8000/12000	1700		

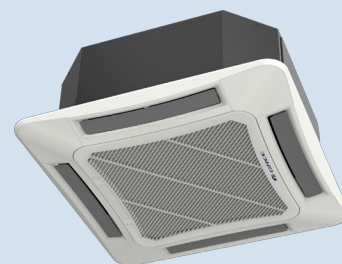

2 NOMENCLATURE

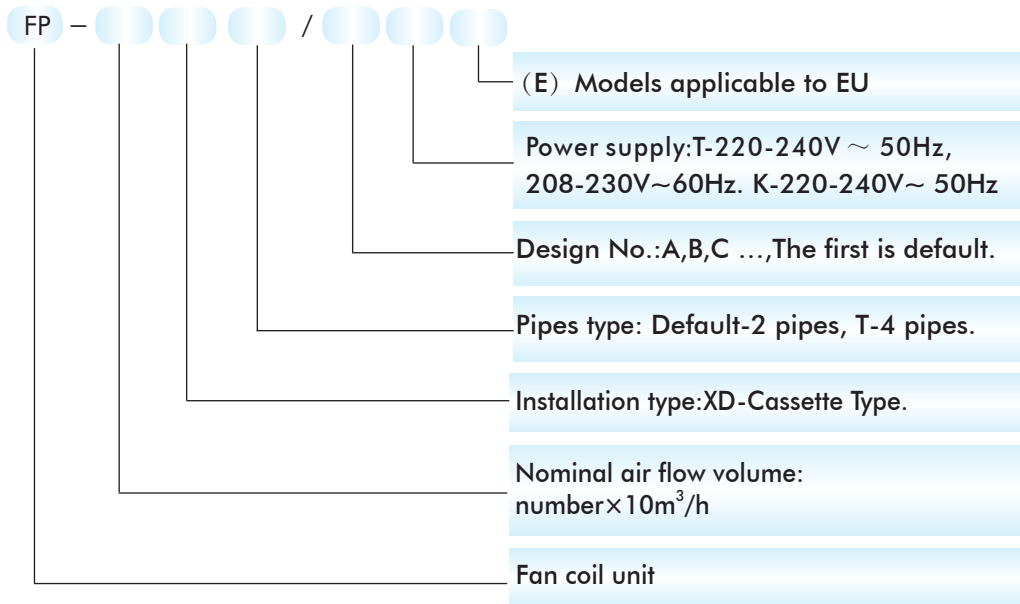

3 FEATURES & BENEFITS

- ◆ Novelty style: the panels exposed are so exquisite that make them look like the indoor adorning.
- ◆ Adopt a great deal of nonmetal material to make them light and desirable.
- ◆ Low noise: Fans are designed by using the principles of dynamics to make sure the air flow volume and reduce the running noise.
- ◆ Duration for cleaning the filter takes only 1/20 of that than ever before. And the cleaning frequency is also extremely lessened.
- ◆ Microcomputer control: The unit will adjust the air flow rate automatically according to the indoor temperature to satisfy different requirements.
- ◆ Less installation space because of the low-profile appearance
- ◆ High cooling (heating) capacity and low noise, variable air volume by using the three-speed motor to satisfy difference requirements.
- ◆ Properly insulated drain pan to avoid generation of condensate water.
- ◆ Cassette Type fan coil units have microcomputer systems and the remote controller has functions as follows:
 - Timing on/off display
 - Fan speed display
 - Mode display (auto, cool, dry, fan, heat)
 - Setting temperature display

4 INSTALLATION

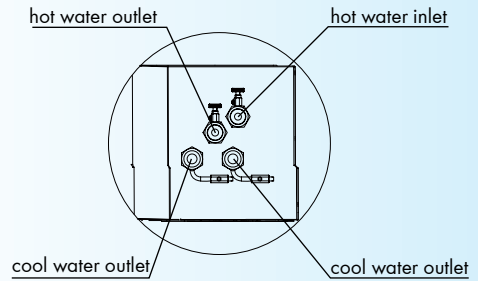
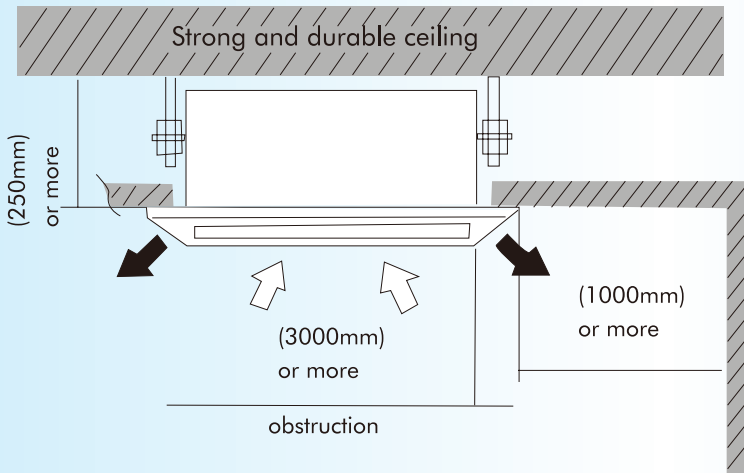

Piping for the 4-pipe FCU

5 DIMENSION

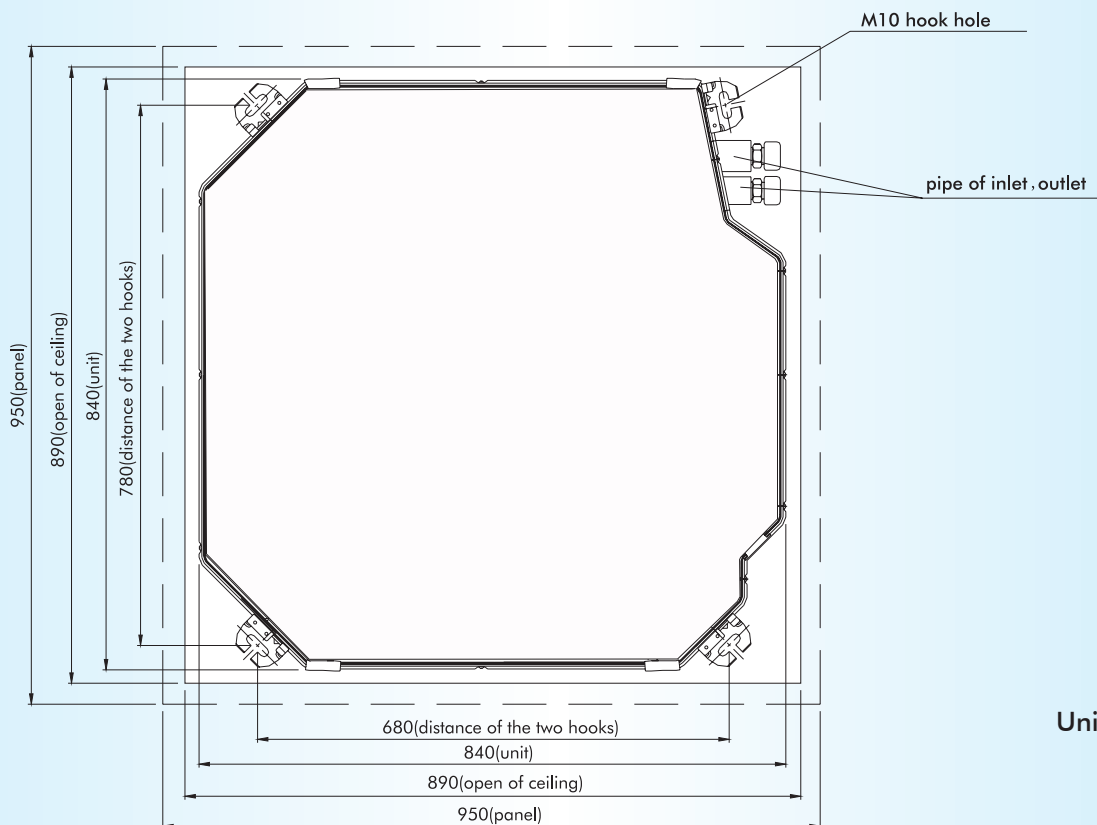

6 SPECIFICATION

Model			FP-85XD/B-T	FP-85XD/B-T	FP-102XD/B-T	FP-102XD/B-T
Power system	Type	V-Ph-Hz	208-230V~ 60Hz	220-240V~ 50Hz	208-230V~ 60Hz	220-240V~ 50Hz
	Input	W	70	75	130	110
Air flow volume	High	CFM	459	471	600	600
		m ³ /h	780	800	1020	1020
	Medium	CFM	371	382	599	599
		m ³ /h	630	650	950	950
	Low	CFM	324	324	529	529
		m ³ /h	550	550	900	900
Capacity	Cooling	W	4600	4500	5400	5000
	Heating	W	7800	5600	9000	6500
Electric heater rated power		W	-	-	-	-
Water system	Cooling water flow volume	l/s	0.22	0.21	0.26	0.24
	Heating water flow volume	l/s	0.22	0.13	0.26	0.17
	Cooling pressure drop	kPa	27	24	48	36
	Heating pressure drop	kPa	24	8	47	13
Sound pressure level		dB(A)	39	39	49	49
Coil	Type	-	Aluminum fin-copper tube	Aluminum fin-copper tube	Aluminum fin-copper tube	Aluminum fin-copper tube
	Operating pressure	MPa	≤1.6MPa	≤1.6MPa	≤1.6MPa	≤1.6MPa
Motor	Type	-	FN35D-1	FN35D-1	FN35D-1	FN35D-1
	Capacitor	μF	2.00	2.00	5.00	5.00
Connection pipe size	Water inlet & outlet	inch	3/4"	3/4"	3/4"	3/4"
	Condensing water drain	mm	25	25	25	25
Outline dimension (W×D×H)	Body	mm	840×840×190	840×840×190	840×840×190	840×840×190
	Panel T01	mm	950×950×60	950×950×60	950×950×60	950×950×60
	Panel TB03	mm	950×950×85	950×950×85	950×950×85	950×950×85
Package dimension (W×D×H)	Body	mm	963×963×272	963×963×272	963×963×272	963×963×272
	Panel T01	mm	1028×1043×130	1028×1043×130	1028×1043×130	1028×1043×130
	Panel TB03	mm	1033×1038×133	1033×1038×133	1033×1038×133	1033×1038×133
Net weight	Body	kg	25.0	25.0	25.0	25.0
	Panel T01	kg	3.0	3.0	3.0	3.0
	Panel TB03	kg	7	7	7	7
Gross weight	Body	kg	33.0	33.0	33.0	33.0
	Panel T01	kg	5.0	5.0	5.0	5.0
	Panel TB03	kg	11	11	11	11
Loading quantity	20'GP(with panel T01)		57	57	57	57
	40'GP (with panel T01)		133	133	133	133
	40'HQ (with panel T01)		149	149	149	149
	20'GP (with panel TB03)		56	56	56	56
	40'GP (with panel TB03)		131	131	131	131
	40'HQ (with panel TB03)		147	147	147	147

Cassette Type Fan Coil Unit Technical Sales Guide

Model			FP-125XD/B-T	FP-125XD/B-T	FP-140XD/B-T	FP-140XD/B-T
Power system	Type	V-Ph-Hz	208-230V~ 60Hz	220-240V~ 50Hz	208-230V~ 60Hz	220-240V~ 50Hz
	Input	W	130	82	140	120
Air flow volume	High	CFM	665	694	794	824
		m ³ /h	1130	1180	1350	1400
	Medium	CFM	529	588	647	735
		m ³ /h	900	1000	1100	1250
	Low	CFM	441	452	588	676
		m ³ /h	750	900	1000	1150
Capacity	Cooling	W	6300	6000	8000	8000
	Heating	W	10000	7800	12000	9000
Electric heater rated power		W	-	-	-	-
Water system	Cooling water flow volume	l/s	0.3	0.29	0.38	0.38
	Heating water flow volume	l/s	0.3	0.18	0.38	0.21
	Cooling pressure drop	kPa	27	24	33	30
	Heating pressure drop	kPa	28	9	29	10
Sound pressure level		dB(A)	43	43	48	50
Coil	Type	-	Aluminum fin-copper tube	Aluminum fin-copper tube	Aluminum fin-copper tube	Aluminum fin-copper tube
	Operating pressure	MPa	≤1.6MPa	≤1.6MPa	≤1.6MPa	≤1.6MPa
Motor	Type	-	FN35B-1	FN35B-1	FN35C	FN35C
	Capacitor	μF	2.00	2.00	4.00	4.00
Connection pipe size	Water inlet & outlet	inch	3/4"	3/4"	3/4"	3/4"
	Condensing water drain	mm	25	25	25	25
Outline dimension (W×D×H)	Body	mm	840×840×240	840×840×240	840×840×240	840×840×240
	Panel T01	mm	950×950×60	950×950×60	950×950×60	950×950×60
	Panel TB03	mm	950×950×85	950×950×85	950×950×85	950×950×85
Package dimension (W×D×H)	Body	mm	963×963×325	963×963×325	963×963×325	963×963×325
	Panel T01	mm	1028×1043×130	1028×1043×130	1028×1043×130	1028×1043×130
	Panel TB03	mm	1033×1038×133	1033×1038×133	1033×1038×133	1033×1038×133
Net weight	Body	kg	27.0	27.0	27.0	27.0
	Panel T01	kg	3.0	3.0	3.0	3.0
	Panel TB03	kg	7	7	7	7
Gross weight	Body	kg	34.0	34.0	35.0	35.0
	Panel T01	kg	5.0	5.0	5.0	5.0
	Panel TB03	kg	11	11	11	11
Loading quantity	20'GP(with panel T01)		50	50	50	50
	40'GP (with panel T01)		121	121	121	121
	40'HQ (with panel T01)		134	134	134	134
	20'GP (with panel TB03)		50	50	50	50
	40'GP (with panel TB03)		117	117	117	117
40'HQ (with panel TB03)		133	133	133	133	

Model			FP-160XD/B-T	FP-160XD/B-T	FP-180XD/B-T	FP-180XD/B-T
Power system	Type	V-Ph-Hz	208-230V~ 60Hz	220-240V~ 50Hz	208-230V~ 60Hz	220-240V~ 50Hz
	Input	W	140	125	160	160
Air flow volume	High	CFM	912	912	1059	1059
		m ³ /h	1550	1550	1800	1800
	Medium	CFM	765	824	824	853
		m ³ /h	1300	1400	1400	1450
	Low	CFM	676	765	765	794
		m ³ /h	1150	1300	1300	1350
Capacity	Cooling	W	9000	8700	10000	9500
	Heating	W	14000	10000	16000	11000
Electric heater rated power		W	-	-	-	-
Water system	Cooling water flow volume	l/s	0.43	0.42	0.48	0.45
	Heating water flow volume	l/s	0.43	0.23	0.48	0.27
	Cooling pressure drop	kPa	34	30	42	34
	Heating pressure drop	kPa	34	11	43	12
Sound pressure level		dB(A)	51	51	50	50
Coil	Type	-	Aluminum fin-copper tube	Aluminum fin-copper tube	Aluminum fin-copper tube	Aluminum fin-copper tube
	Operating pressure	MPa	≤1.6MPa	≤1.6MPa	≤1.6MPa	≤1.6MPa
Motor	Type	-	FN35C	FN35C	FN50K-1	FN50K-1
	Capacitor	μF	5.00	5.00	3.50	3.50
Connection pipe size	Water inlet & outlet	inch	3/4"	3/4"	3/4"	3/4"
	Condensing water drain	mm	25	25	25	25
Outline dimension (W×D×H)	Body	mm	840×840×240	840×840×240	840×840×320	840×840×320
	Panel T01	mm	950×950×60	950×950×60	950×950×60	950×950×60
	Panel TB03	mm	950×950×85	950×950×85	950×950×85	950×950×85
Package dimension (W×D×H)	Body	mm	963×963×325	963×963×325	963×963×409	963×963×409
	Panel T01	mm	1028×1043×130	1028×1043×130	1028×1043×130	1028×1043×130
	Panel TB03	mm	1033×1038×133	1033×1038×133	1033×1038×133	1033×1038×133
Net weight	Body	kg	27.0	27.0	32.0	32.0
	Panel T01	kg	3.0	3.0	3.0	3.0
	Panel TB03	kg	7	7	7	7
Gross weight	Body	kg	35.0	35.0	41.0	41.0
	Panel T01	kg	5.0	5.0	5.0	5.0
	Panel TB03	kg	11	11	11	11
Loading quantity	20'GP(with panel T01)		50	50	42	42
	40'GP (with panel T01)		121	121	98	98
	40'HQ (with panel T01)		134	134	112	112
	20'GP (with panel TB03)		50	50	42	42
	40'GP (with panel TB03)		117	117	98	98
40'HQ (with panel TB03)		133	133	112	112	

Cassette Type Fan Coil Unit Technical Sales Guide

Model			FP-200XD/B-T	FP-200XD/B-T
Power system	Type	V-Ph-Hz	208-230V~ 60Hz	220-240V~ 50Hz
	Input	W	230	210
Air flow volume	High	CFM	1176	1176
		m ³ /h	2000	2000
	Medium	CFM	912	1000
		m ³ /h	1550	1700
	Low	CFM	735	853
		m ³ /h	1250	1450
Capacity	Cooling	W	13000	13000
	Heating	W	19000	14600
Electric heater rated power		W	-	-
Water system	Cooling water flow volume	l/s	0.62	0.62
	Heating water flow volume	l/s	0.62	0.25
	Cooling pressure drop	kPa	35	34
	Heating pressure drop	kPa	35	30
Sound pressure level		dB(A)	55	55
Coil	Type	-	Aluminum fin-copper tube	Aluminum fin-copper tube
	Operating pressure	MPa	≤1.6MPa	≤1.6MPa
Motor	Type	-	FN50K-2	FN50K-2
	Capacitor	μF	5.00	5.00
Connection pipe size	Water inlet & outlet	inch	3/4"	3/4"
	Condensing water drain	mm	25	25
Outline dimension (W×D×H)	Body	mm	840×840×320	840×840×320
	Panel T01	mm	950×950×60	950×950×60
	Panel TB03	mm	950×950×85	950×950×85
Package dimension (W×D×H)	Body	mm	963×963×409	963×963×409
	Panel T01	mm	1028×1043×130	1028×1043×130
	Panel TB03	mm	1033×1038×133	1033×1038×133
Net weight	Body	kg	33.0	33.0
	Panel T01	kg	3.0	3.0
	Panel TB03	kg	7	7
Gross weight	Body	kg	42.0	42.0
	Panel T01	kg	5.0	5.0
	Panel TB03	kg	11	11
Loading quantity	20'GP(with panel T01)		42	42
	40'GP (with panel T01)		98	98
	40'HQ (with panel T01)		112	112
	20'GP (with panel TB03)		42	42
	40'GP (with panel TB03)		98	98
	40'HQ (with panel TB03)		112	112

Model			FP-68XDT/B-K	FP-85XDT/B-K	FP-125XDT/B-K	FP-180XDT/B-K
Power system	Type	V-Ph-Hz	220-240V~ 50Hz	220-240V~ 50Hz	220-240V~ 50Hz	220-240V~ 50Hz
	Input	W	82	82	135	191
Air flow volume	High	CFM	400	500	736	1059
		m ³ /h	680	850	1250	1800
	Medium	CFM	364	450	652	897
		m ³ /h	618	764	1108	1525
	Low	CFM	336	410	597	836
		m ³ /h	571	697	1014	1421
Capacity	Cooling	W	3500	4100	6000	8000
	Heating	W	6000	6800	9500	13000
Electric heater rated power		W	-	-	-	-
Water system	Cooling water flow volume	l/s	0.21	0.24	0.29	0.44
	Heating water flow volume	l/s	0.17	0.19	0.27	0.36
	Cooling pressure drop	kPa	34.14	56.71	43.07	39.65
	Heating pressure drop	kPa	76.44	86.08	91.94	102.21
Sound pressure level		dB(A)	39	40	43	50
Coil	Type	-	Aluminum fin-copper tube	Aluminum fin-copper tube	Aluminum fin-copper tube	Aluminum fin-copper tube
	Operating pressure	MPa	≤1.6MPa	≤1.6MPa	≤1.6MPa	≤1.6MPa
Motor	Type	-	FN35D-1	FN35D-1	FN35B-1	FN50K-1
	Capacitor	μF	2.0	3.0	4.0	4.5
Connection pipe size	Water inlet & outlet	inch	3/4"	3/4"	3/4"	3/4"
	Condensing water drain	mm	25	25	25	25
Outline dimension (W×D×H)	Body	mm	840×840×190	840×840×190	840×840×240	840×840×320
	Panel TB03	mm	950×950×85	950×950×85	950×950×85	950×950×85
Package dimension (W×D×H)	Body	mm	960×960×257	960×960×257	960×960×310	960×960×394
	Panel TB03	mm	1033×1038×133	1033×1038×133	1033×1038×133	1033×1038×133
Net weight	Body	kg	25.0	25.0	27.0	32.0
	Panel TB03	kg	7	7	7	7
Gross weight	Body	kg	33.0	33.0	34.0	41.0
	Panel TB03	kg	11	11	11	11
Loading quantity	20'GP (with panel TB03)		56	56	50	42
	40'GP (with panel TB03)		131	131	121	98
	40'HQ (with panel TB03)		147	147	134	112

Cassette Type Fan Coil Unit Technical Sales Guide

2 pipes

Model			FP-51XD/A-K	FP-68XD/A-K	FP-85XD/B-T (E)	FP-102XD/B-T (E)
Power system	Type	V-Ph-Hz	220-240V~ 50Hz	220-240V~ 50Hz	220-240V~ 50Hz	220-240V~ 50Hz
	Input	W	73	78	81	110
Air flow volume	High	CFM	300	388	471	470
		m ³ /h	510	660	800	940
	Medium	CFM	235	330	385	453
		m ³ /h	400	560	665	770
	Low	CFM	176	270	347	394
		m ³ /h	300	460	590	670
Capacity	Cooling	W	2750	3400	4500	5000
	Heating	W	3400	3800	5400	6100
Electric heater rated power		W	-	-	-	-
Water system	Cooling water flow volume	l/s	0.13	0.18	0.22	0.24
	Heating water flow volume	l/s	0.16	0.20	0.27	0.29
	Cooling pressure drop	kPa	30	38	27	34
	Heating pressure drop	kPa	30	38	37	46
Sound pressure level		dB(A)	46	46	39	49
Coil	Type	-	Aluminum fin-copper tube	Aluminum fin-copper tube	Aluminum fin-copper tube	Aluminum fin-copper tube
	Operating pressure	MPa	≤1.6MPa	≤1.6MPa	≤1.6MPa	≤1.6MPa
Motor	Type	-	FN30L	FN30L	FN35D-1	FN35D-1
	Capacitor	μF	2.0	2.0	2.00	5.00
Connection pipe size	Water inlet & outlet	inch	3/4"	3/4"	3/4"	3/4"
	Condensing water drain	mm	25	25	25	25
Outline dimension (W×D×H)	Body	mm	664×594×292	670×670×60	670×670×60	840×840×190
	Panel	mm	670×670×60	670×670×60	950×950×85	950×950×85
Package dimension (W×D×H)	Body	mm	778×733×300	775×730×285	963×963×272	963×963×272
	Panel	mm	673×673×85	778×733×300	1033×1038×133	1033×1038×133
Net weight	Body	kg	20	20	25.0	25.0
	Panel	kg	3.5	3.5	7	7
Gross weight	Body	kg	24	24	33.0	33.0
	Panel	kg	5	5	11	11
Loading quantity	20'GP (with panel)		147	147	56	56
	40'GP (with panel)		315	315	131	131
	40'HQ (with panel)		360	360	147	147

Model			FP-125XD/B-T (E)	FP-140XD/B-T (E)	FP-160XD/B-T (E)	FP-180XD/B-T (E)	FP-200XD/D-K (E)
Power system	Type	V-Ph-Hz	220-240V~ 50Hz	220-240V~ 50Hz	220-240V~ 50Hz	220-240V~ 50Hz	208-230V~ 60Hz
	Input	W	100	143	152	160	140
Air flow volume	High	CFM	641	823	882	964	1000
		m ³ /h	1090	1400	1500	1640	1700
	Medium	CFM	506	682	706	800	841
		m ³ /h	860	1160	1200	1360	1430
	Low	CFM	447	588	588	706	676
		m ³ /h	760	1000	1000	1200	1150
Capacity	Cooling	W	6000	7400	8400	9500	11100
	Heating	W	6900	8400	9000	10500	11700
Electric heater rated power		W	-	-	-	-	-
Water system	Cooling water flow volume	l/s	0.29	0.35	0.40	0.45	0.53
	Heating water flow volume	l/s	0.33	0.40	0.43	0.49	0.56
	Cooling pressure drop	kPa	21	30	30	33	21
	Heating pressure drop	kPa	32	38	36	41	25
Sound pressure level		dB(A)	43	50	51	50	55
Coil	Type	-	Aluminum fin-copper tube	Aluminum fin-copper tube	Aluminum fin-copper tube	Aluminum fin-copper tube	Aluminum fin-copper tube
	Operating pressure	MPa	≤1.6MPa	≤1.6MPa	≤1.6MPa	≤1.6MPa	≤1.6MPa
Motor	Type	-	FN35B-1	FN35C	FN35C	FN50K-1	FN60C-ZL
	Capacitor	μF	2.00	4.00	5.00	3.50	-
Connection pipe size	Water inlet & outlet	inch	3/4"	3/4"	3/4"	3/4"	3/4"
	Condensing water drain	mm	25	25	25	25	25
Outline dimension (W×D×H)	Body	mm	840×840×240	840×840×240	840×840×240	840×840×320	840×840×320
	Panel T01	mm	950×950×60	950×950×60	950×950×60	950×950×60	950×950×60
	Panel TB03	mm	950×950×85	950×950×85	950×950×85	950×950×85	950×950×85
Package dimension (W×D×H)	Body	mm	963×963×325	963×963×325	963×963×325	963×963×409	963×963×409
	Panel T01	mm	1028×1043×130	1028×1043×130	1028×1043×130	1028×1043×130	1028×1043×130
	Panel TB03	mm	1033×1038×133	1033×1038×133	1033×1038×133	1033×1038×133	1033×1038×133
Net weight	Body	kg	27.0	27.0	27.0	32.0	33.0
	Panel T01	kg	3.0	3.0	3.0	3.0	3.0
	Panel TB03	kg	7	7	7	7	7
Gross weight	Body	kg	34.0	35.0	35.0	41.0	42.0
	Panel T01	kg	5.0	5.0	5.0	5.0	5.0
	Panel TB03	kg	11	11	11	11	11
Loading quantity	20'GP(with panel T01)		50	50	50	42	42
	40'GP (with panel T01)		121	121	121	98	98
	40'HQ (with panel T01)		134	134	134	112	112
	20'GP (with panel TB03)		50	50	50	42	42
	40'GP (with panel TB03)		117	117	117	98	98
	40'HQ (with panel TB03)		133	133	133	112	112

Cassette Type Fan Coil Unit Technical Sales Guide

4 pipes

Model			FP-68XDT/B-K(E)	FP-85XDT/B-K(E)	FP-125XDT/B-K(E)	FP-180XDT/B-K(E)
Power system	Type	V-Ph-Hz	220-240V~ 50Hz	220-240V~ 50Hz	220-240V~ 50Hz	220-240V~ 50Hz
	Input	W	82	90	135	191
Air flow volume	High	CFM	400	500	736	1000
		m ³ /h	680	850	1250	1700
	Medium	CFM	364	450	652	897
		m ³ /h	618	764	1108	1525
	Low	CFM	336	410	597	836
		m ³ /h	571	697	1014	1421
Capacity	Cooling	W	3500	4500	6000	8000
	Heating	W	5800	6800	9200	12000
Electric heater rated power		W	-	-	-	-
Water system	Cooling water flow volume	l/s	0.21	0.24	0.29	0.44
	Heating water flow volume	l/s	0.17	0.19	0.27	0.36
	Cooling pressure drop	kPa	44	53	41	48
	Heating pressure drop	kPa	76	83	84	97
Sound pressure level		dB(A)	39	40	43	50
Coil	Type	-	Aluminum fin-copper tube	Aluminum fin-copper tube	Aluminum fin-copper tube	Aluminum fin-copper tube
	Operating pressure	MPa	≤1.6MPa	≤1.6MPa	≤1.6MPa	≤1.6MPa
Motor	Type	-	FN35D-1	FN35D-1	FN35B-1	FN50K-1
	Capacitor	μF	2.0	3.0	4.0	4.5
Connection pipe size	Water inlet & outlet	inch	3/4"	3/4"	3/4"	3/4"
	Condensing water drain	mm	25	25	25	25
Outline dimension (W×D×H)	Body	mm	840×840×190	840×840×190	840×840×240	840×840×320
	Panel TB03	mm	950×950×85	950×950×85	950×950×85	950×950×85
Package dimension (W×D×H)	Body	mm	960×960×257	960×960×257	960×960×310	960×960×394
	Panel TB03	mm	1033×1038×133	1033×1038×133	1033×1038×133	1033×1038×133
Net weight	Body	kg	25.0	25.0	27.0	32.0
	Panel TB03	kg	7	7	7	7
Gross weight	Body	kg	33.0	33.0	34.0	41.0
	Panel TB03	kg	11	11	11	11
Loading quantity	20'GP (with panel TB03)		56	56	50	42
	40'GP (with panel TB03)		131	131	121	98
	40'HQ (with panel TB03)		147	147	134	112

Testing condition:

For 60Hz :

The FCU designed for installation indoor. The environmental temperature is from 5°C to 43°C, water working temperature is from 7°C to 60°C.

The temperature exchange efficiency and enthalpy exchange efficiency are tested under these testing conditions as below:

1). Cooling capacity: air 27°C DB, 19.5°C WB, water temperature: intake 7°C, outlet 12°C.

2). Heating capacity: air 21°C DB, Water temperature intake 60°C, the water-flow volume is same as Cooling capacity .

3). Freeze-up : air 27°C DB, 24°C WB, water temperature intake 6°C, outlet 9°C.

4). Sound power level according to ISO 5151. Sound pressure level are calculated at the below of air-outlet 1m and 1m distance. The noise are tested before leaving factory.

For 50 Hz :

The FCU designed for installation indoor. The environmental temperature is from 5°C to 43°C, water working temperature is from 7°C to 60°C.

The temperature exchange efficiency and enthalpy exchange efficiency are tested under these testing conditions as below:

1). Cooling capacity: air 27°C DB , 19°C WB, water temperature intake 7°C, outlet 12°C.

2). Heating capacity: air 20°C DB , Water temperature intake 50°C, outlet 40°C.

For the tow-row coils applicable to EU, the entering/leaving water temperature is 45°C and 40°C ; and for the four-row coils, the entering/leaving water temperature is 65°C /55°C .

3). Freeze-up : air 27°C DB, 24°C WB , water temperature 6°C intake , 10°C outlet .

4). Sound power level according to ISO 5151. Sound pressure level are calculated at the below of air-outlet 1m and 1m distance. The noise are tested before leaving factory.

For 4 pipes:

The FCU designed for installation indoor. The environmental temperature is from 5°C to 43°C, water working temperature is from 7°C to 70°C.

The temperature exchange efficiency and enthalpy exchange efficiency are tested under these testing conditions as below:

1). Cooling capacity: air 27°C DB , 19°C WB, water temperature intake 7°C, outlet 12°C.

2). Heating capacity: air 20°C DB , Water temperature intake 70°C, outlet 60°C.

3). Freeze-up : air 27°C DB, 24°C WB , water temperature 6°C intake , 10°C outlet .

4). Sound power level according to ISO 5151. Sound pressure level are calculated at the below of air-outlet 1m and 1m distance. The noise are tested before leaving factory.

7 PERFORMANCE RATING

7.1 Export sales for EU countries

Entering air dry/wet-bulb temperature (°C)	Entering/leaving water temperature (°C)					
	5/10	5/11	5/12	6/11	6/12	6/13
24/17	0.77	0.65	0.57	0.66	0.58	0.51
25/18	0.92	0.75	0.65	0.81	0.66	0.58
26/19	1.07	0.91	0.75	0.96	0.77	0.66
27/19	1.14	1.00	0.82	1.03	0.87	0.73
28/21	1.37	1.24	1.08	1.26	1.13	0.93
30/22	1.52	1.40	1.26	1.41	1.29	1.14

Entering air dry/wet-bulb temperature (°C)	Entering/leaving water temperature (°C)				
	7/12	7/13	7/14	8/13	9/14
24/17	0.59	0.52	0.46	0.53	0.48
25/18	0.69	0.59	0.52	0.60	0.53
26/19	0.84	0.68	0.59	0.73	0.61
27/19	1	0.75	0.65	0.81	0.70
28/21	1.15	1.01	0.81	1.04	0.92
30/22	1.31	1.18	1.00	1.20	1.08

7.2 Export sales for other countries

Entering air dry/wet-bulb temperature (°C)	Entering/leaving water temperature (°C)					
	5/10	5/11	5/12	6/11	6/12	6/13
24/17	0.84	0.70	0.62	0.72	0.63	0.56
25/18	1.00	0.81	0.70	0.88	0.72	0.63
26/19	1.16	0.99	0.82	1.04	0.84	0.72
27/19.5	1.24	1.08	0.89	1.12	0.95	0.79
28/21	1.49	1.35	1.18	1.37	1.23	1.01
30/22	1.65	1.52	1.37	1.54	1.40	1.24



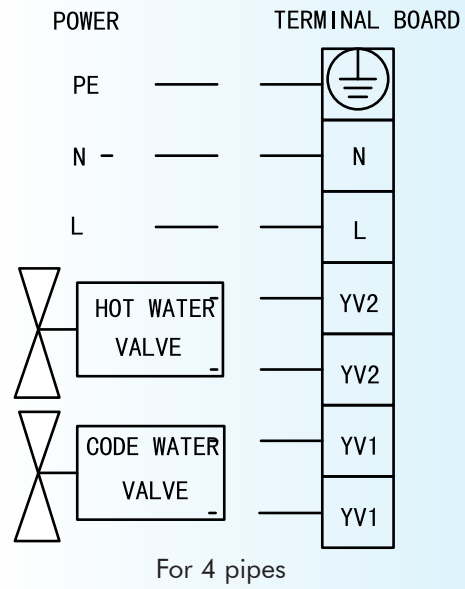
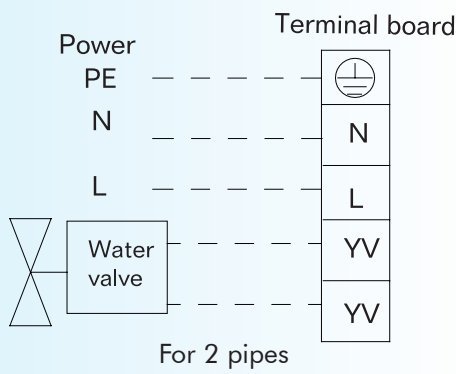

Entering air dry/wet-bulb temperature (°C)	Entering/leaving water temperature (°C)				
	7/12	7/13	7/14	8/13	9/14
24/17	0.64	0.57	0.50	0.57	0.52
25/18	0.75	0.64	0.56	0.65	0.58
26/19	0.92	0.74	0.64	0.80	0.67
27/19.5	1.00	0.81	0.70	0.88	0.76
28/21	1.26	1.10	0.88	1.13	1.00
30/22	1.42	1.28	1.09	1.30	1.17

8 WIRING DIAGRAM



9 OPERATION & CONTROLS

Key-part	Specification for wiring & function
Three Speed Switch	The unit motor is a single-phase, permanent split capacitor with the three speeds tapings HIGH/MEDIUM/LOW wired to the terminal block with color-coded wires. Terminal 1—BLACK-HIGH SPEED Terminal 2—YELLOW-MEDIUM SPEED Terminal 3—BLUE-LOW SPEED
Motor	The fan coil unit is equipped with the three-speed motor.
Motor Bearings	The motors have permanently lubricated ball bearings as a standard offering.
Insulation	The motors are provided with class B insulation

Model name	Appearance	Model name	Appearance
Wired remote controller XK26		Door controller	
wireless remote controller YB1FA		Communication module	

Gree Electric Appliances, Inc. of Zhuhai, founded in 1991, is the world's largest air conditioner enterprise integrating R&D, manufacturing, marketing and services.

Technology Innovation and quality are always our priority. With efforts of thousands of Gree's engineers, we own more than 3500 patents for our products.

Nowadays, we have 7 production bases in Zhuhai, Chongqing, Hefei and Zhengzhou(China), as well as Brazil, Pakistan and Vietnam, with annual production capacity of 30 million sets of residential air conditioners and 4 million sets of commercial air conditioners.

With the installation of Gree commercial air conditioners in important projects at home and abroad like Media Village for 2008 Beijing Olympic Games, Stadiums for 2010 World Cup in South Africa, as well as India Telecom base station, Gree commercial air conditioners are ready to develop steadily to every corner in the world, to present a more comfortable and harmonious working environment and family atmosphere.



Add: West Jinji Rd, Qianshan Zhuhai, Guangdong, China 519070

Tel: (+86-756)8614883 Fax: (+86-756)8614998

Http://www.gree.com Email: gree@gree.com.cn

For continuous improvement in the products, Gree reserves the right to modify the product specification and appearance in this manual without notice and without incurring any obligations.