

# GREE

making better air conditioners

## FAN COIL UNIT

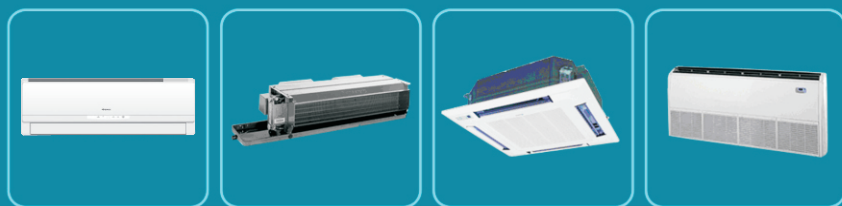

TECHNICAL SALES GUIDE-50Hz/60Hz



The photos of products on the cover are for reference only, the actual appearance of certain product may be different.

# CONTENTS

1.DESCRPTION .....	2
2.NOMENCLATURE.....	3
3.FEATURES & BENEFITS.....	4
4.EXPLODED VIEW.....	5
5.INSTALLATION .....	12
6.UNIT DIMENSIONS & WEIGHT.....	14
7.SPECIFICATION.....	17
8.PERFORMANCE RATING .....	24
9.WIRING DIAGRAM.....	32
10.OPERATION & CONTROLS.....	34

## 1 DESCRIPTION

GREE FP series fan coil air conditioners are designed specially to meet the varied requirements of zone cooling or heating using chilled water or hot water. fan coils can be applied to two or four pipe systems to satisfy the requirements of a wide variety of air conditioning or heating application. GREE FCU (Fan coil unit) is available in concealed and exposed versions for ceiling and floor mounted installation. They offer effective zone control and are especially suitable for use in apartments, hotels, shopping centers, office buildings and hospitals.

GREE FCU is available four configurations: WA:Concealed Ceiling ;WM-Floor And Ceiling Type ; XD-Cassette type;B-Wall mounted



## 2 NOMENCLATURE

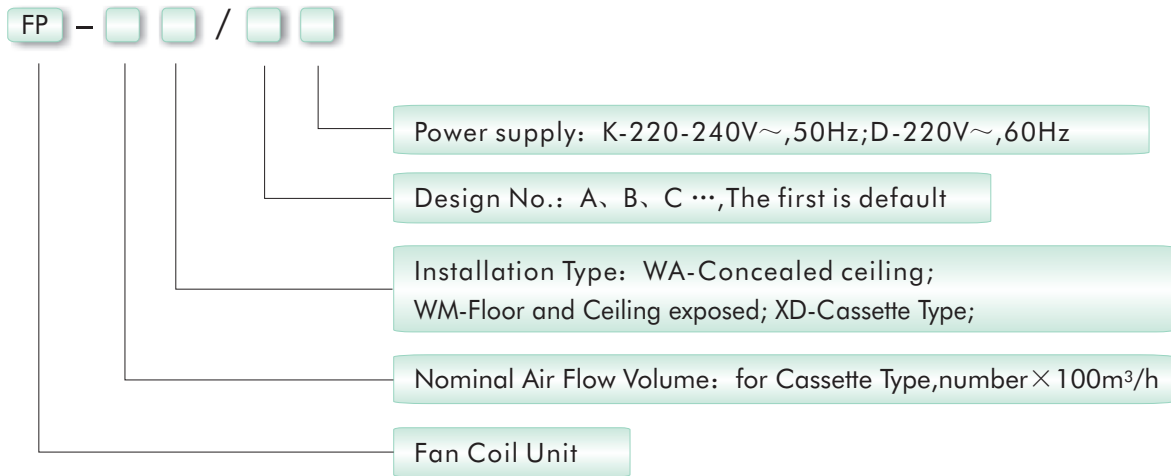

Wall Mounted Nomenclature :

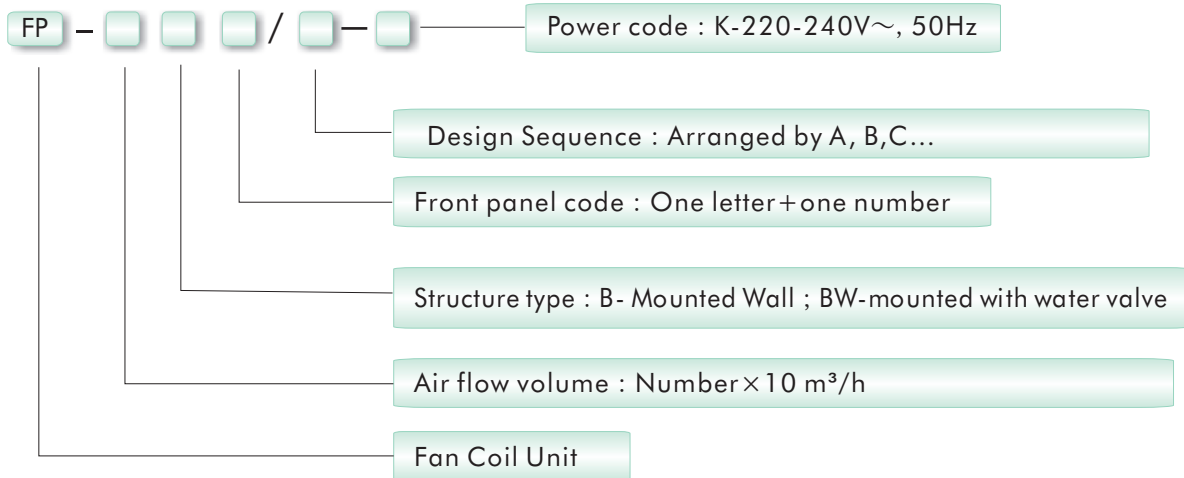

### 3 FEATURES & BENEFITS

#### **Horizontal Concealed:**

- ◆ Small enthalpy difference, that is suitable to the place which highly requires the comfort and precision.
- ◆ Economize space because of the little height.
- ◆ High cooling (heating) capacity and low noise, Adjust the air flow volume with three-speed motor to satisfy different requirements.
- ◆ Drain pan is adhibited with heat preservation material to avoid the coagulate water.
- ◆ Improve on the place of the deflation and drain valve to improve the efficiency of heat transfer and avoid the pipeline freezing in winter.

#### **Floor And Ceiling、Cassette Type、Wall Mounted:**

- ◆ Novelty style: the panels exposed are so exquisite that make them look like the indoor adorning.
- ◆ Adopt a great deal of nonmetal material to make them light and desirable.
- ◆ Low noise: Fans are designed by using the principles of dynamics to make sure the air flow volume and fall the running noise.
- ◆ The depurative period protracts 20 times by using excellent filter, no need to clean filter frequently.
- ◆ Microcomputer control: The unit will adjust the air flow rate automatically according to the indoor temperature to satisfy different requirements.
- ◆ Economize space because of the little height.
- ◆ High cooling (heating) capacity and low noise, Adjust the air flow volume with three-speed motor to satisfy different requirements.
- ◆ Drain pan is adhibited with heat preservation material to avoid the coagulate water.
- ◆ Cassette Type & Wall Mounted fan coil units have microcomputer control system, the remote controller has functions as:
  - ◆ timing on/off display
  - ◆ fan speed display
  - ◆ mode display(auto、cool、dry、fan、heat)
  - ◆ setting temperature display

## 4 PRODUCT DATA

### 1. Concealed Ceiling:

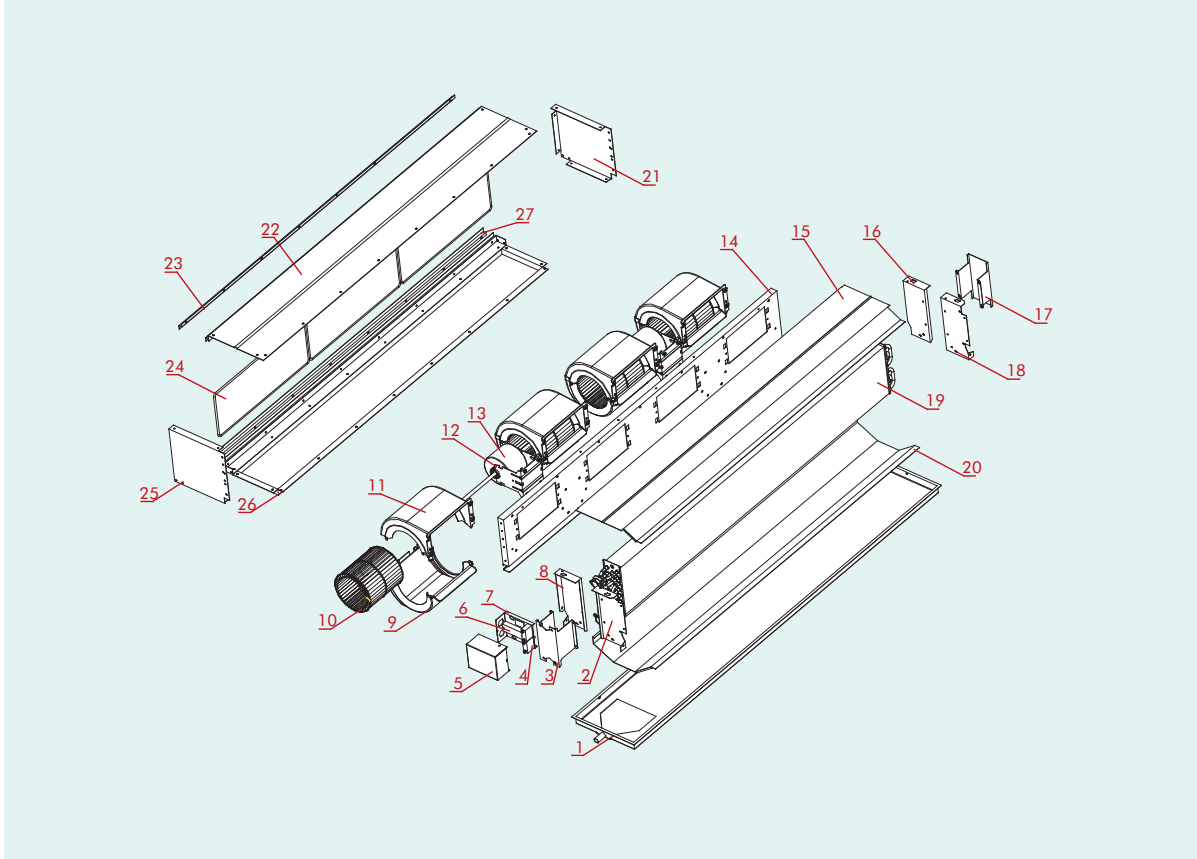

No.	Component	Available as	No.	Component	Available as
1	Drain Pan	◇	15	Top Panel	◇
2	Left terminal plate 2	◇	16	Right terminal plate 1	◇
3	Manifold Support	◇	17	Cooling coil protecting plate	◇
4	Capacitance	◇	18	Right terminal plate 2	◇
5	Motor Terminal Cover	◇	19	Cooling Coil	◇
6	Motor Terminals	◇	20	Bottom Panel	◇
7	Support Plate for Terminals	◇	21	Side Panel of Plenum(Left)	□
8	Left terminal plate 1	◇	22	Top Panel of plenum	□
9	Front propeller housing	◇	23	Top Flange of Plenum	□
10	Centrifugal fan	◇	24	Filter	□
11	Rear propeller housing	◇	25	Side Panel of Plenum(Right)	□
12	Motor Support Plate	◇	26	Bottom Panel of plenum	□
13	Motor	◇	27	Bottom Flange of Plenum	□
14	Fan Deck	◇	Legend: ◇ Standard □ Option ■ Special Request		

## 2.Wall mounted:

Model:FP-34BA2/A-K ; Model: FP-51BA2/A-K ;  
Exploded Views:

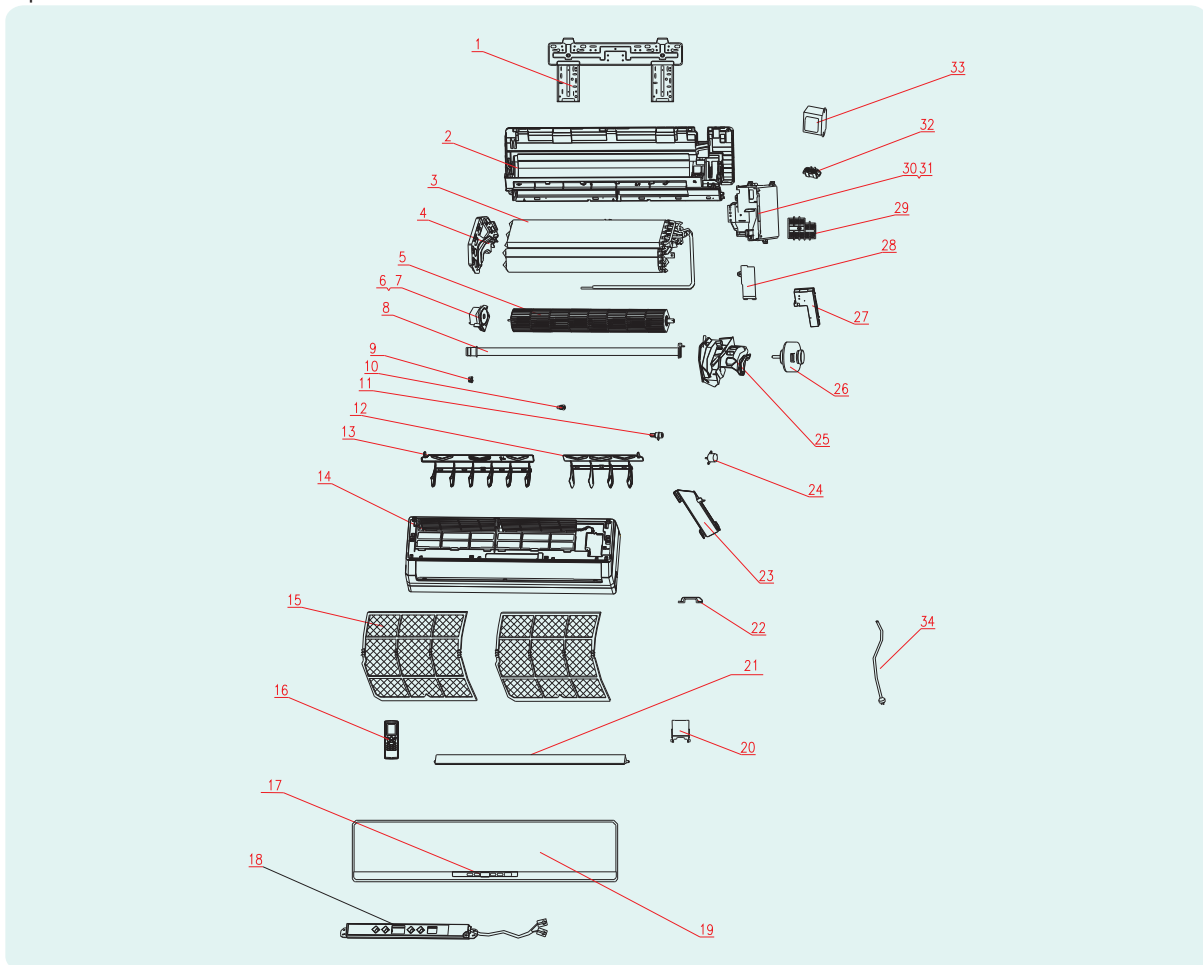

No.	Name of part	Part code	Quantity
1	Wall-Mounting Frame	01252013	1
2	Rear Case	2220245401	1
3	Sufer Cooler Assy	01126406	1
4	Evaporator Support	24212091	1
5	Cross Flow Fan	10352017	1
6	Ring of Bearing	26152022	1
7	Bearing cushion rubber base	76512203	1
8	Volute tongue	26112163	1
9	Left Axile Bush	10512037	1
10	Crank	10582070	1
11	Axile Bush	10542008	1
12	Swing Louver1	10512156	1
13	Swing Louver2	10512155	1
14	Front Case	20012123	1
15	Filter	1112220401	2
16	Remote Control YB1FA	30510041	1
17	Decorate Piece	20192265	1

No.	Name of part	Part code	Quantity
18	Receiver Board D5183Z	30565056	1
19	Front Panel	200121505	1
20	Screw Cover	24252016	1
21	Guide Louver	10512157	1
22	Wire Clamp	71010003	1
23	Rear Clamp	26112164	1
24	Motor MP24AA	1521210801	1
25	Motor Clamp	26112161	1
26	Motor FN20J-PG	150120874	1
27	Electric Box Cover 1	20122103	1
28	Covering Plate2	20122075	1
29	Terminal Board	42010262	1
30	Electric Box	20112082	1
31	Main PCB Z5P251A	30225043	1
32	Jumping Connector	4202300117 ① 4202300125 ②	1
33	Transformer 48X26G	43110233	1
34	Power Cable	400220112	1

Note : ① only is part of FP-34BA2/A-K.

② only is part of FP-51BA2/A-K.

# FAN COIL UNIT TECHNICAL SALES GUIDE

Model:FP-68BA2/A-K ; Model: FP-85BA2/A-K ;

Exploded Views:

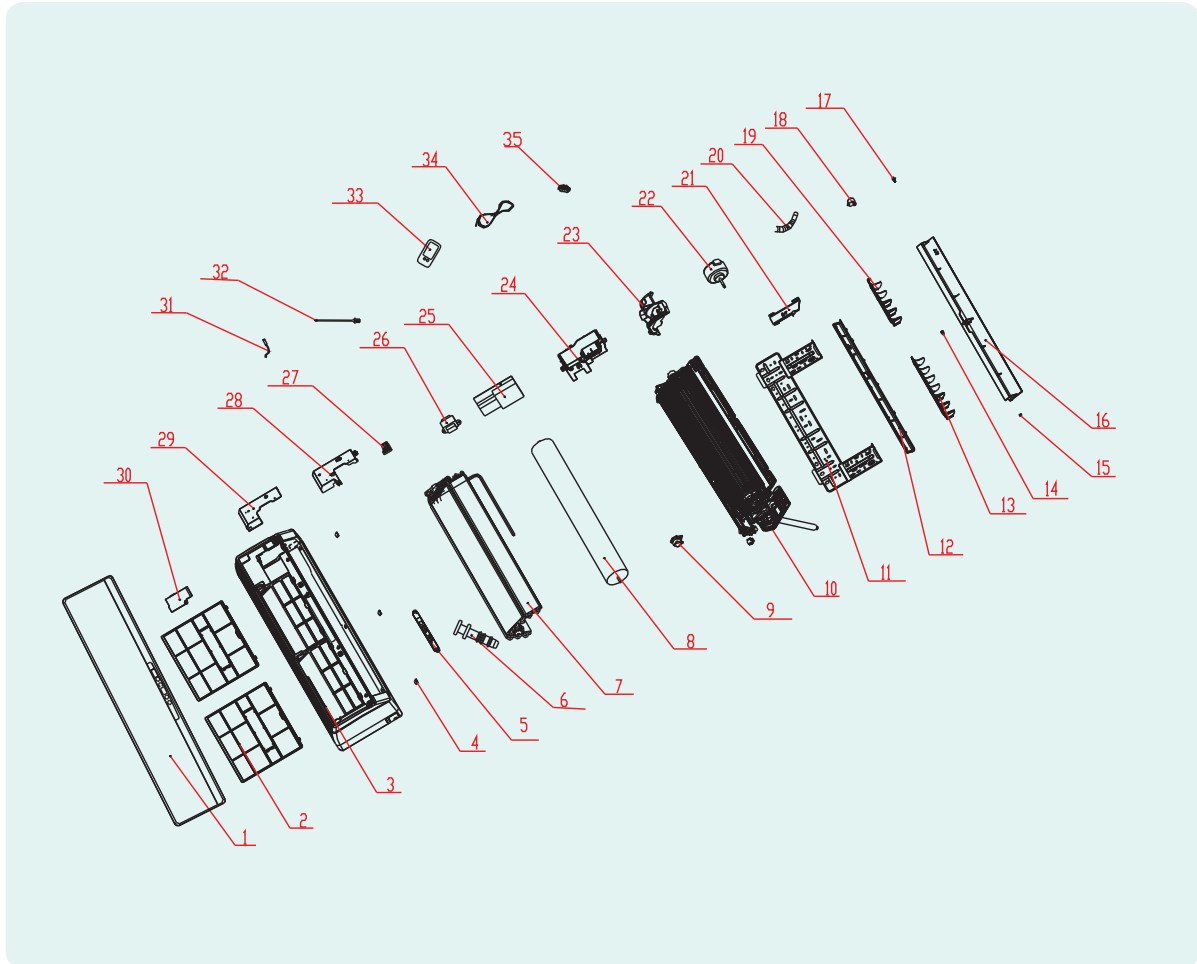

No.	Name of part	Part code	Quantity
1	Front Panel Assy	2001216801	1
2	Filter Sub-Assy	1112220401	2
3	Front Case	20012139	1
4	Screw Cover	24252016	1
5	Display Board	30565056	1
6	Rubber Plug (Water Tray)	76712012	1
7	Evaporator Assy	01126406	1
8	Cross Flow Fan	10352017	1
9	Ring of Bearing	26152022	1
10	Rear Case assy	2220210301	1
11	Wall Mounting Frame	01252013	1
12	Helicoid tongue	26112163	1
13	Air Louver 1	10512156	1
14	Axile Bush	10542008	1
15	Left Axile Bush	10512037	1
16	Guide Louver	10512157	1
17	crank	10582070	1
18	Stepping Motor	1521210801	1

No.	Name of part	Part code	Quantity
19	Air Louver 2	10512155	1
20	Drainage hose	0523001401	1
21	Pipe Clamp	26112164	1
22	Fan Motor	150120874	1
23	Motor Press Plate	26112161	1
24	Electric Box	01396200	1
25	Main Board	30225043	1
26	Transformer	43110233	1
27	Terminal Board	42010262	1
28	Electric Box Cover1	20122103	1
29	Shield cover of Electric Box	01412036	1
30	Electric Box Cover2	20122075	1
31	Tube Sensor	390000453	1
32	Ambient Temperature Sensor	390000592	1
33	Remote Controller	30510041	1
34	Power Cord	400220112	1
35	Jumping Connector	4202300126①	1
		4202300120②	1

Note : ① only is part of FP-68BA2/A-K.

② only is part of FP-85BA2/A-K.

Model:FP-51BWA2/A-K ;  
Exploded Views:

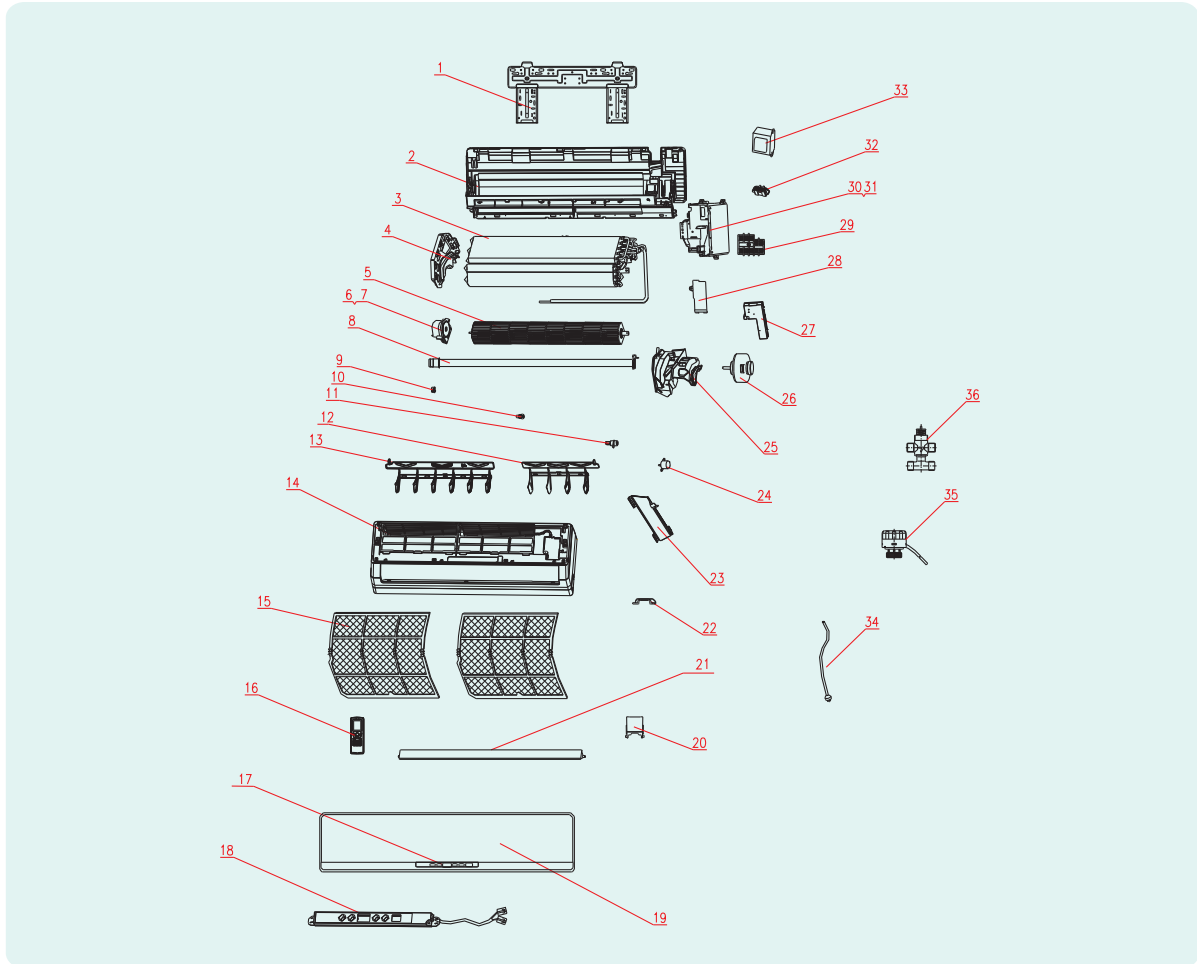

No	Name of part	Part code	Quantity
1	Wall-Mounting Frame	01252013	1
2	Rear Case	2220245401	1
3	Sufer Cooler Assy	01126406	1
4	Evaporator Support	24212091	1
5	Cross Flow Fan	10352017	1
6	Ring of Bearing	26152022	1
7	Bearing cushion rubber base	76512203	1
8	Volute tongue	26112163	1
9	Left Axile Bush	10512037	1
10	Crank	10582070	1
11	Axile Bush	10542008	1
12	Swing Louver1	10512156	1
13	Swing Louver2	10512155	1
14	Front Case	20012123	1
15	Filter	1112220401	2
16	Remote Control YB1FA	30510041	1
17	Decorate Piece	20192265	1
18	Receiver Board D5183Z	30565056	1

No	Name of part	Part code	Quantity
19	Front Panel	20012150S	1
20	Screw Cover	24252016	1
21	Guide Louver	10512157	1
22	Wire Clamp	71010003	1
23	Rear Clamp	26112164	1
24	Motor MP24AA	1521210801	1
25	Motor Clamp	26112161	1
26	Motor FN20J-PG	150120874	1
27	Electric Box Cover 1	20122103	1
28	Covering Plate2	20122075	1
29	Terminal Board	42010262	1
30	Electric Box	20112082	1
31	Main PCB Z5P251A	30225043	1
32	Jumping Connector	4202300129	1
33	Transformer 48X26G	43110233	1
34	Power Cable	400220112	1
35	Loop of electromagnetic valve	43040012	1
36	Electromagnetic valve	43007001	1



# FAN COIL UNIT TECHNICAL SALES GUIDE

Model: FP-85BWA2/A-K ;

Exploded Views:

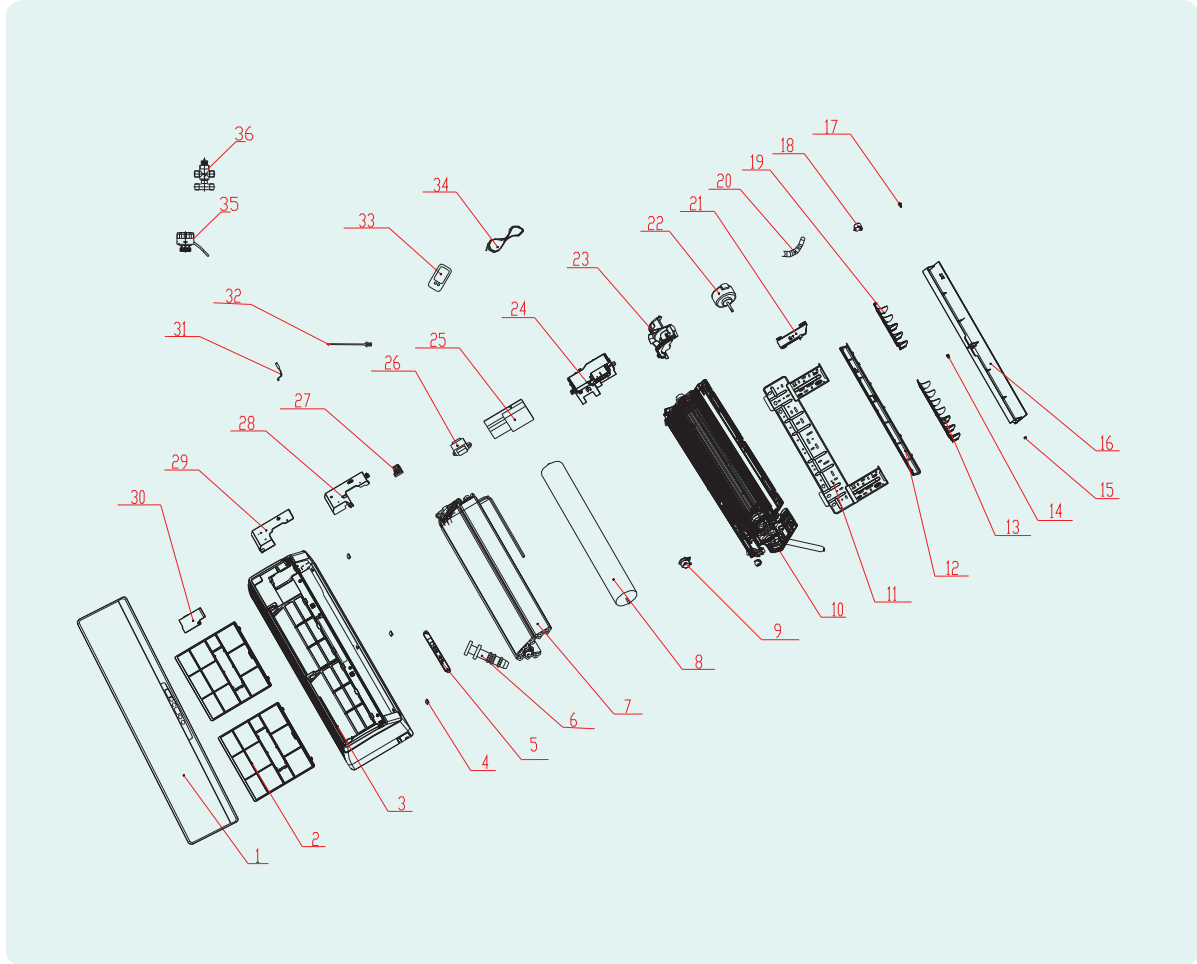

No	Name of part	Part code	Quantity
1	Front Panel Assy	2001216801	1
2	Filter Sub-Assy	1112220401	2
3	Front Case	20012139	1
4	Screw Cover	24252016	1
5	Display Board	30565056	1
6	Rubber Plug (Water Tray)	76712012	1
7	Evaporator Assy	01126406	1
8	Cross Flow Fan	10352017	1
9	Ring of Bearing	26152022	1
10	Rear Case assy	2220210301	1
11	Wall Mounting Frame	01252013	1
12	Helicoid tongue	26112163	1
13	Air Louver 1	10512156	1
14	Axile Bush	10542008	1
15	Left Axile Bush	10512037	1
16	Guide Louver	10512157	1
17	crank	10582070	1
18	Stepping Motor	1521210801	1

No	Name of part	Part code	Quantity
19	Air Louver 2	10512155	1
20	Drainage hose	0523001401	1
21	Pipe Clamp	26112164	1
22	Fan Motor	150120874	1
23	Motor Press Plate	26112161	1
24	Electric Box	01396200	1
25	Main Board	30225043	1
26	Transformer	43110233	1
27	Terminal Board	42010262	1
28	Electric Box Cover 1	20122103	1
29	Shield cover of Electric Box	01412036	1
30	Electric Box Cover2	20122075	1
31	Tube Sensor	390000453	1
32	Ambient Temperature Sensor	390000592	1
33	Remote Controller	30510041	1
34	Power Cord	400220112	1
35	Loop of electromagnetic valve	43040012	1
36	Electromagnetic valve	43007001	1

### 3. Cassette type:

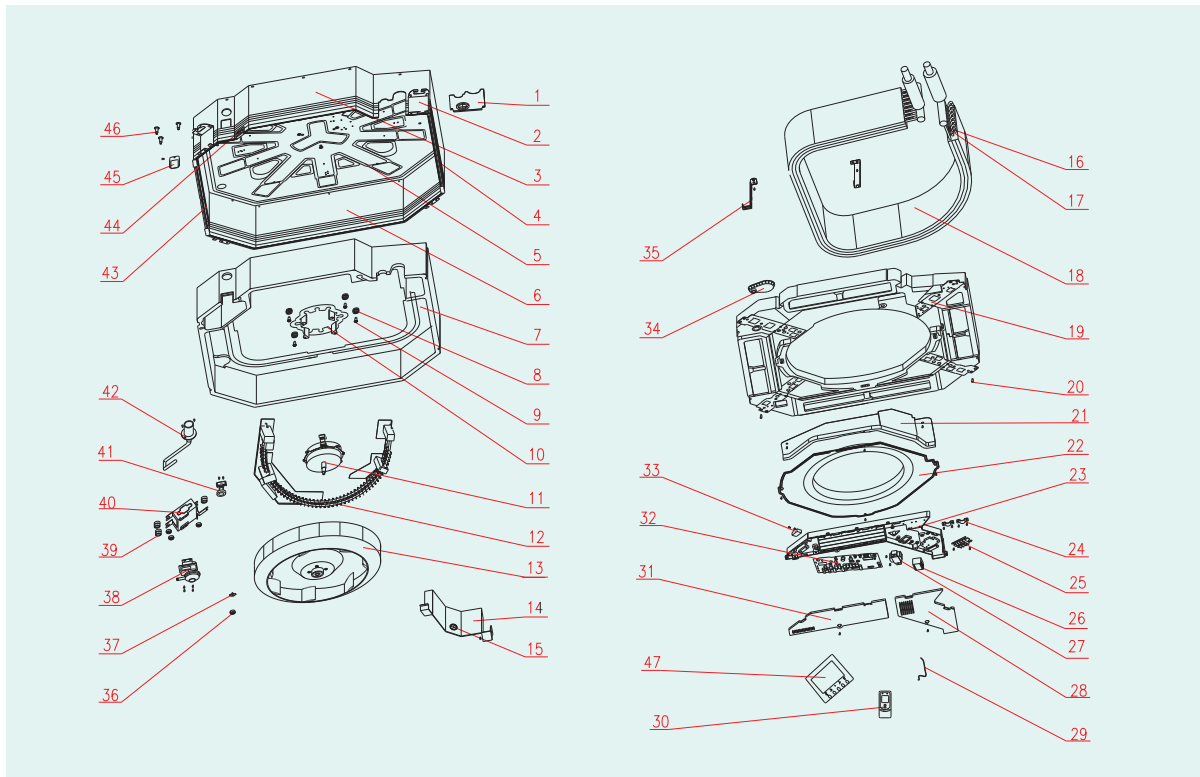

No.	Component	Available as	No.	Component	Available as
1	Tube-exit Plate	◇	25	Terminal Board	◇
2	Body Fixing Plate	◇	26	relay	◇
3	Front Side Plate	◇	27	TransformerSC28B1	◇
4	Left Side Plate	◇	28	Electric Box Cover I	◇
5	Base Plate	◇	29	Room sensor	◇
6	Rear Side Plate	◇	30	Remote Controller ZY512B(GREE)	◇
7	Bottom Foam	◇	31	Electric Box Cover II	◇
8	Motor Gasket	◇	32	Main PCB Z5935A1	◇
9	Bolt	◇	33	CapacitorCBB61/4.5uF/450V	◇
10	Motor Support	◇	34	Drainage Plastic	◇
11	Motor FN50T	◇	35	Evap Support	◇
12	Electric Heater	◇	36	Nut with Washer	◇
13	Centrifugal Fan	◇	37	Fixer	◇
14	Evap Connection	◇	38	Water Pump	◇
15	Cable-cross Loop	◇	39	Pump Gasket	◇
16	Tube sensor	◇	40	Pump Support	◇
17	sensor insert B	◇	41	Water Level Switch	◇
18	Heat exchanger	◇	42	Pump Drainpipe	◇
19	Water Tray	◇	43	Right Side Plate	◇
20	Screw	◇	44	Cable-cross Block	◇
21	Electric Plate	◇	45	Pump Cover Board	◇
22	Flow-guide Loop	◇	46	Bolt	◇
23	Electric Box	◇	47	Wired remote controller	□
24	Wire Clamp	◇	Legend: ◇Standard □Option		

## 4. Ceiling exposed:

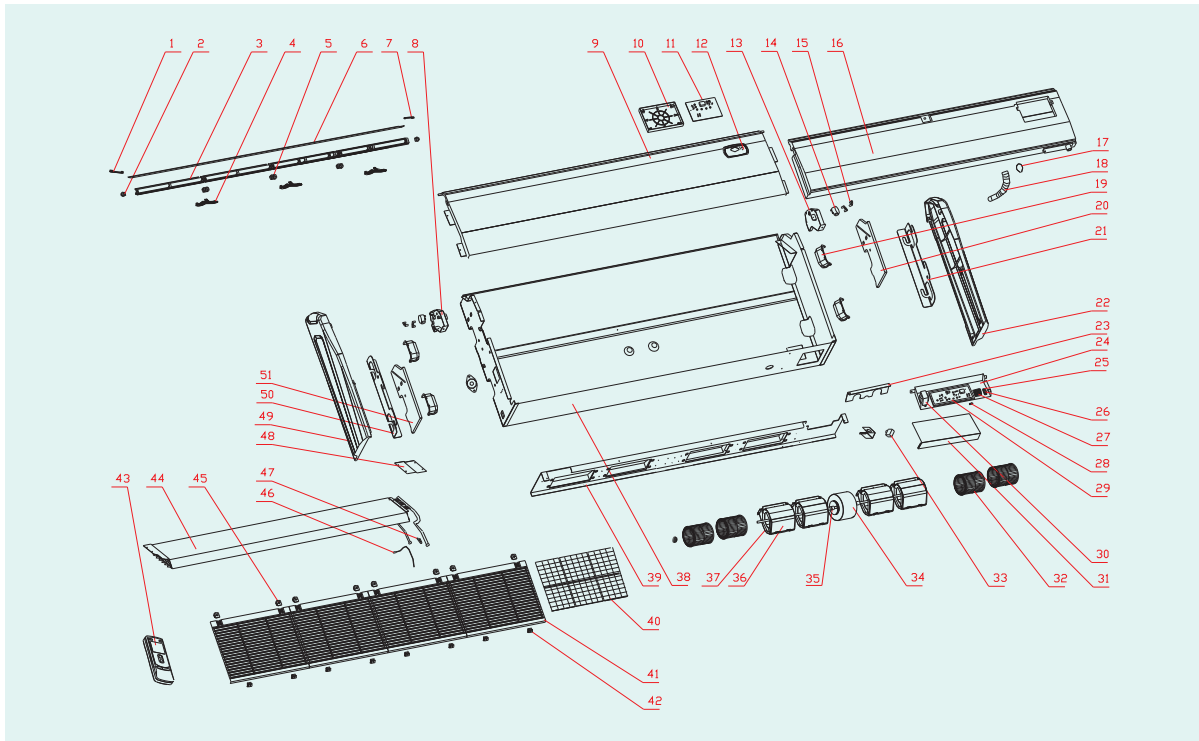

No.	Component	Available as	No.	Component	Available as
1	Left Decoration Plate	◇	27	Terminal Board	◇
2	Shaft of Louver	◇	28	Protective Tube T5AL 250V	◇
3	Guide Louver Bracket	◇	29	Main Board	◇
4	Guide Louver Fixed Mount	◇	30	Transformer 57X25C	◇
5	Shaft of Louver	◇	31	Electric Box Cover	◇
6	Guide Louver	◇	32	Centifugal Fan	◇
7	Right Decoration Plate	◇	33	Capacitor	◇
8	Left Mounting Plate of Swing Motor	◇	34	Motor	◇
9	Panel Sub-assy	◇	35	Axletree	◇
10	Mounting Box Sub-Assy	◇	36	Front propeller housing	◇
11	Display Board	◇	37	Rear propeller housing	◇
12	Button Panel Sub-Assy	◇	38	Rear Side Plate Sub-assy	◇
13	Right Mounting Plate of Swing Motor	◇	39	Motor Support Sub-assy	◇
14	Stepping Motor MP35CA	◇	40	Filter Sub-assy	◇
15	Press Plate of Swing Motor	◇	41	Panel Grille	◇
16	Water Tray Component	◇	42	Panel Grille Buckle 2	◇
17	Pipe Hoop	◇	43	Remote Control Y512	◇
18	Drain Pipe Sub-Assy	◇	44	Cooling coil assy	◇
19	Handle	◇	45	Panel Grille Buckle 1	◇
20	Foam Sub-assy of Right Side Plate	◇	46	Environment Sensor 15KS-XH-2P-1500mm	◇
21	Mounting Plate	◇	47	Sensor Insert B	◇
22	Decorative Board	◇	48	Cover Plate Of Evaporator	◇
23	Mounting Plate Sub-assy	◇	49	Left Decorative Board	◇
24	Electric Box Sub-Assy	◇	50	Left Mounting Plate	◇
25	Press Wire Holder	◇	51	Foam Sub-assy of Left Side Plate	◇
26	Press Wire Board	◇		Legend: ◇Standard □Option	

# 5 INSTALLATION

Concealed Ceiling:

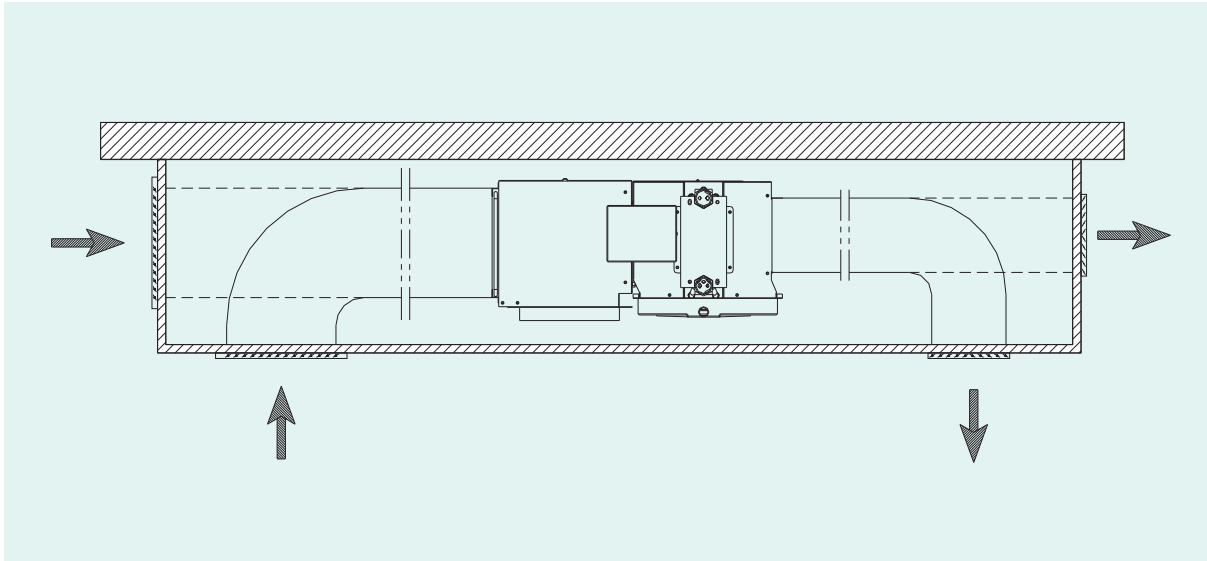

Cassette type:

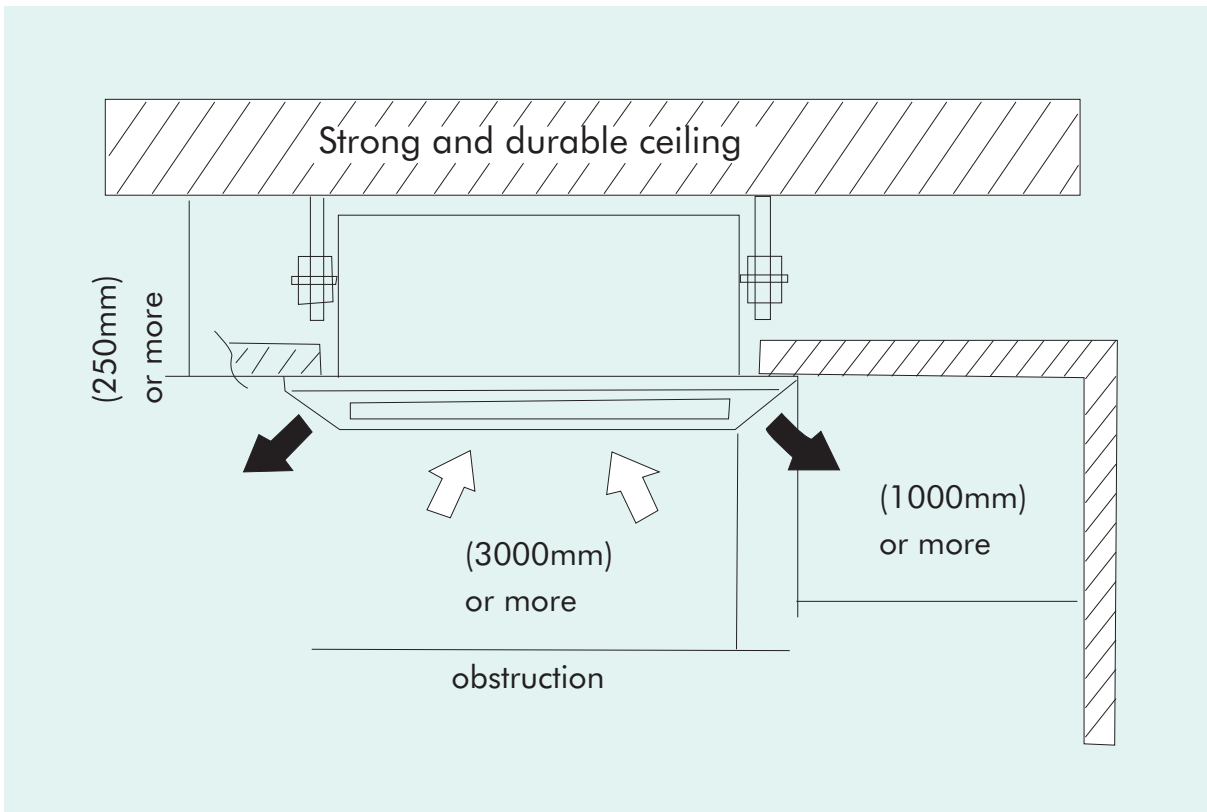

Floor And Ceiling Type :

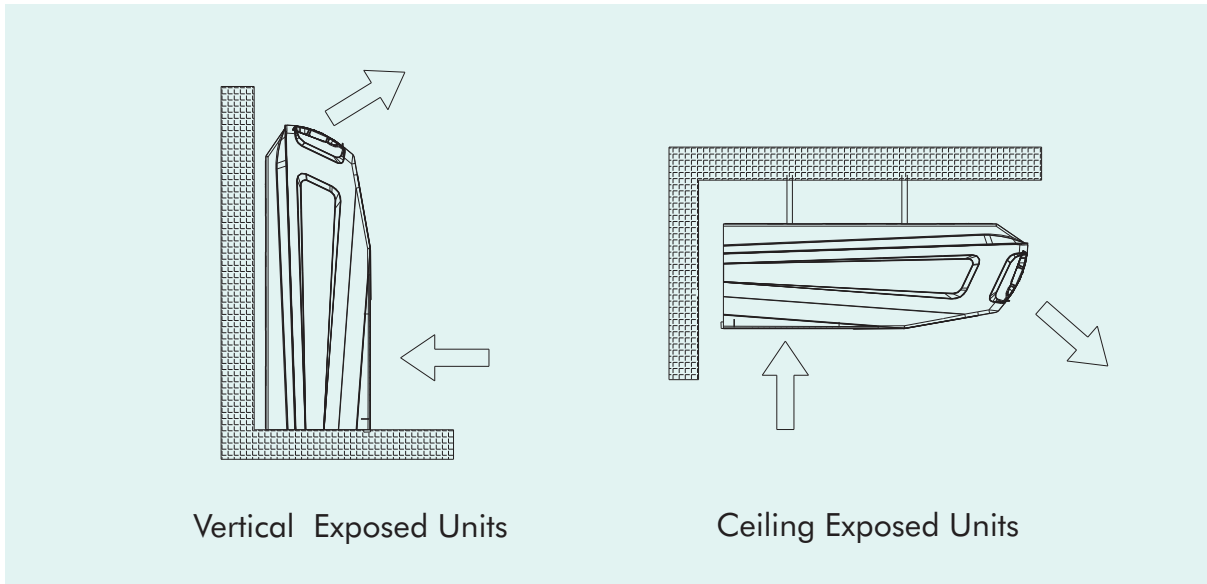

Wall mounted:

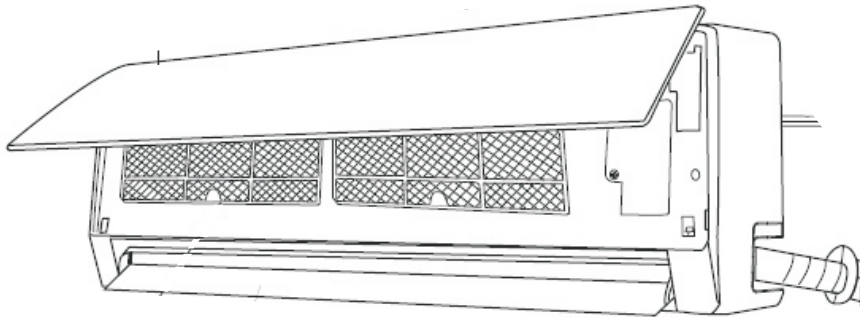

## IMPORTANT NOTES

- \*The installation must be done by trained and qualified service personnel with reliability according to this manual.
  - \*Contact with service center before installation to avoid the malfunction due to unprofessional installation.
  - \*When picking up and moving the units, you must be guided by trained and qualified personnel.
- The air conditioner should be connected to the earth, correctly, if not, contact with the service center.

# 6 UNIT DIMENSIONS & WEIGHT

## 1. Concealed Ceiling

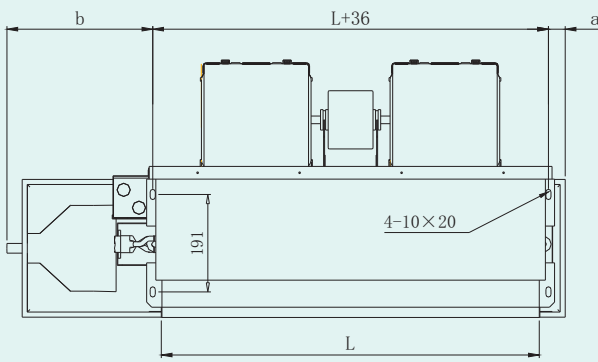
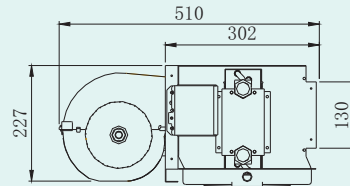
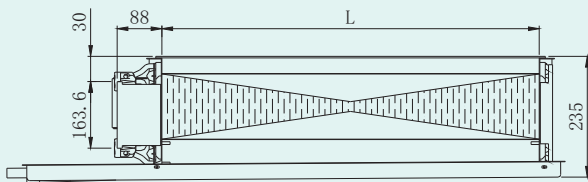

Model	L (mm)	a (mm)	b (mm)	h (mm)	Weight (kg)
FP-34WA(H)-K	490	45	310	245	14
FP-51WA(H)-K	620	45	310	245	15
FP-68WA(H)-K	740	45	310	245	16.5
FP-85WA(H)-K	820	45	310	245	18
FP-102WA(H)-K	820	45	310	245	19
FP-136WA(H)-K	1400	75	250	245	28.5
FP-170WA(H)-K	1400	75	250	245	34
FP-204WA(H)-K	1400	75	250	245	35

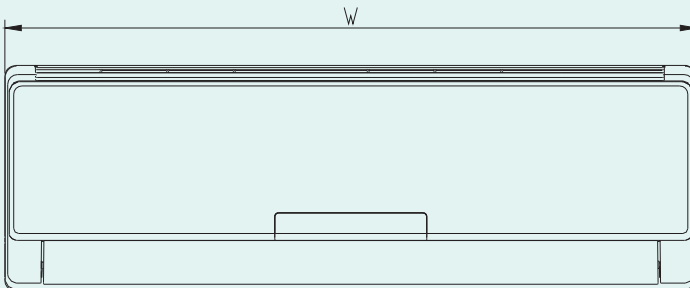
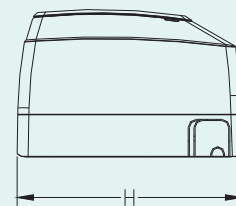
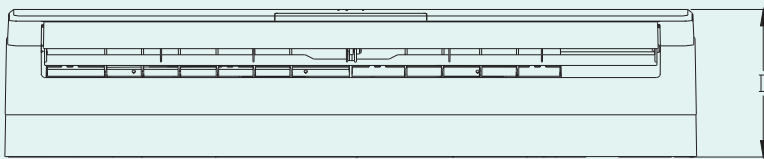

Model	W (mm)	H (mm)	D (mm)	Weight (kg)
FP-34BA2/A-K	854	275	180	11
FP-51B(W)A2/A-K	854	275	180	13
FP-68BA2/A-K	940	298	200	11
FP-85B(W)A2/A-K	940	298	200	11

## 2.Cassette type

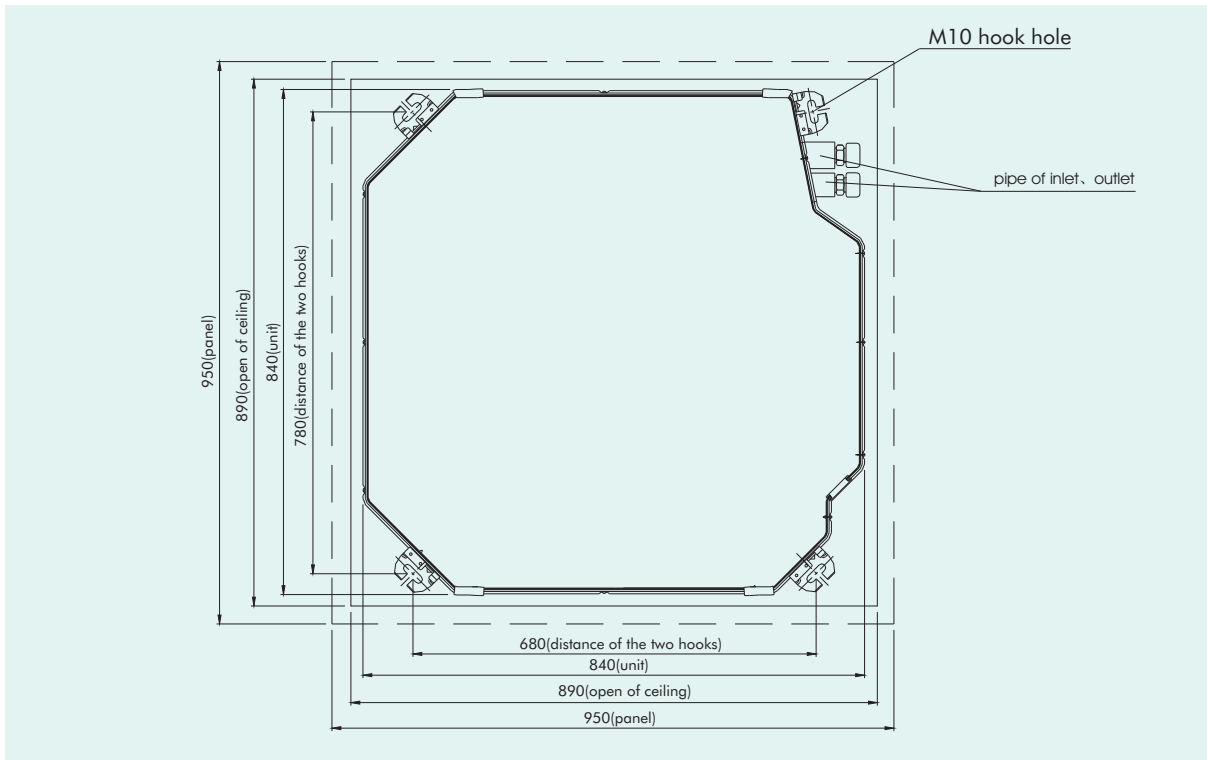

### 3. Floor And Ceiling Type :

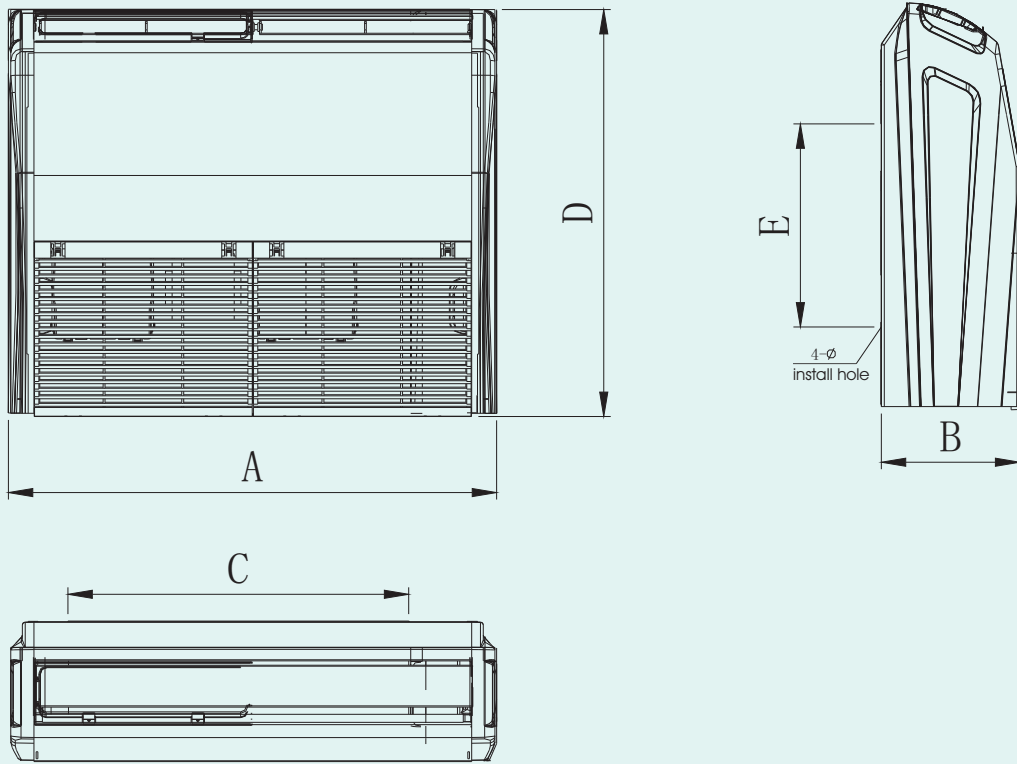

Model	A (mm)	B (mm)	C (mm)	D (mm)	E (mm)	Weight (kg)
FP-34	836	238	740	695	260	26
FP-51	836	238	740	695	260	26
FP-68	1300	188	1202	600	260	34
FP-85	1300	188	1202	600	260	34
FP-102	1300	188	1202	600	260	34
FP-136	1590	238	1491	695	260	48.5
FP-170	1590	238	1491	695	260	48.5
FP-204	1590	238	1491	695	260	48.5



## 7 SPECIFICATION

### 1. Concealed Ceiling

Function			Model	FP-34WA-K	FP-51WA-K	FP-68WA-K	FP-85WA-K
				FP-34WAH-K	FP-51WAH-K	FP-68WAH-K	FP-85WAH-K
Performance	Air Flow Volume	High	m <sup>3</sup> /h	340	510	680	850
		Medium		248	394	495	638
		Low		213	263	330	425
	Total Cooling Capacity		W	1850	2800	3600	4500
	Total Heating Capacity		W	3050	4400	5500	7000
	Water Flow		L/s	0.10	0.14	0.17	0.21
	Water Resistance		KPa	12	21	16	23
	Sound Pressure Level	High Static Pressure	dB(A)	35	38	40	42
				38	40	42	44
Static Pressure		Pa	Standard is 12Pa High static pressure is 30 Pa				
Coil	Type		Aluminum fin-copper tube				
	Operating Pressure		≤1.5MPa				
Motor	Type		Isolation E Capacitor startup three-speed Motor				
	Fan Motor Capacitor	uF	2.5	2.5	2.5	3	
	Power Supply(V-Ph-Hz)		220-240V~ 50Hz				
Output Motor of Fan Motor	standard	W	37	45	62	75	
	High Static Pressure		42	55	68	80	
Dimension of Water Pipe (inch)			Rc3/4 (inner connection)	Rc3/4 (inner connection)	Rc3/4 (inner connection)	Rc3/4 (inner connection)	
N.W/G.W		kg	14/17	15/19.5	16.5/21	18/22	
Outline dimension (W×D×H)		mm	840×245×505	970×245×505	1090×245×505	1170×245×505	
package dimension (W×D×H)		mm	900×275×560	1030×275×560	1150×275×560	1230×275×560	
Loading Quantity (20' Container)		unit	204	176	160	136	
Loading Quantity (40' Container)		unit	428	360	336	296	
Loading Quantity (40' High Cube Container)		unit	428	360	336	296	

Function			Model	FP-102WA-K	FP-136WA-K	FP-170WA-K	FP-204WA-K
				FP-102WAH-K	FP-136WAH-K	FP-170WAH-K	FP-204WAH-K
Performance	Air Flow Volume	High	m <sup>3</sup> /h	1020	1360	1700	2040
		Medium		788	1095	1275	1575
		Low		525	730	850	1050
	Total Cooling Capacity		W	5500	7350	9200	11000
	Total Heating Capacity		W	8900	11000	14000	17000
	Water Flow		L/s	0.27	0.36	0.45	0.50
	Water Resistance		KPa	36	38	38	40
	Sound Pressure Level	standard	dB(A)	44	46	48	50
		High Static Pressure		46	47	49	52
Static Pressure		Pa	Standard is 12Pa High static pressure is 30 Pa				
Coil	Type		Aluminum fin-copper tube				
	Operating Pressure		≤1.5MPa				
Motor	Type		Isolation E Capacitor startup three-speed Motor				
	Fan Motor Capacitor	uF	2.5	2.5	2.5	3	
	Power Supply(V-Ph-Hz)		220-240V~ 50Hz				
Output Motor of Fan Motor	standard	W	96	120	145	189	
	High Static Pressure		102	140	174	195	
Dimension of Water Pipe (inch)			Rc3/4 (inner connection)	Rc3/4 (inner connection)	Rc3/4 (inner connection)	Rc3/4 (inner connection)	
N.W/G.W		kg	19/24	28.5/35	34/39	35/40	
Outline dimension (W×D×H)		mm	1170×245×505	1720×245×505	1720×245×505	1720×245×505	
package dimension (W×D×H)		mm	1230×275×560	1780×275×560	1780×275×560	1780×275×560	
Loading Quantity (20' Container)		unit	136	100	100	100	
Loading Quantity (40' Container)		unit	296	204	204	204	
Loading Quantity (40' High Cube Container)		unit	296	204	204	204	

## 2. Floor And Ceiling Type:

Function		Model	FP-34WM-K	FP-51WM-K	FP-68WM-K	FP-85WM-K
Performance	Air Flow Volume	m <sup>3</sup> /h	340	510	680	850
	Total Cooling Capacity	kW	1800	2800	3600	4500
	Total Heating Capacity	kW	2800	4150	5400	6750
	Water Flow	m <sup>3</sup> /h	0.364	0.5	0.63	0.8
	Water Resistance	kPa	9.8	9.8	36.5	36.5
	Sound Pressure Level	dB(A)	48	48	49	49
Coil	Type	Aluminum fin-copper tube				
	Operating Pressure	≤1.5MPa				
Motor	Type	Isolation E Capacitor startup three-speed Motor				
	Power Supply(V-Ph-Hz)	220~240V/1Ph / 50Hz				
Output of Fan Motor		W	40	40	62	77
Dimension of Water Pipe(inch)		G3/4(external connection)				
N.W/G.W		kg	26/35	26/35	34/38	34/38
Outline dimension (W×D×H)		mm	238×834×694	834×694×238	130×60×188	130×60×188
package dimension (W×D×H)		mm	960×830×330	960×830×330	1414×724×248	1414×724×248
Loading Quantity( 20' Container )		unit	112	112	108	108
Loading Quantity( 40' Container )		unit	224	224	222	222
Loading Quantity ( 40' High Cube Container )		unit	270	270	246	246

Function		Model	FP-102WM-K	FP-136WM-K	FP-170WM-K	FP-204WM-K
Performance	Air Flow Volume	m <sup>3</sup> /h	1020	1360	1700	2040
	Total Cooling Capacity	kW	5400	7200	9000	10800
	Total Heating Capacity	kW	8100	10800	13500	16200
	Water Flow	m <sup>3</sup> /h	0.93	1.3	1.5	1.95
	Water Resistance	kPa	30.8	34.8	38.4	42.8
	Sound Pressure Level	dB(A)	49	51	52	55
Coil	Type	Aluminum fin-copper tube				
	Operating Pressure	≤1.5MPa				
Motor	Type	Isolation E Capacitor startup three-speed Motor				
	Power Supply(V-Ph-Hz)	220~240V/1Ph / 50Hz				
Output of Fan Motor		W	99	162	240	275
Dimension of Water Pipe(inch)		G3/4(external connection)				
N.W/G.W		kg	34/38	48.5/57	48.5/57	48.5/57
Outline dimension (W×D×H)		mm	1300×600×188	159×695×238	1590×695×230	159×695×238
package dimension (W×D×H)		mm	1414×724×248	1714×830×330	1714×830×330	1714×830×330
Loading Quantity( 20' Container )		unit	108	58	58	58
Loading Quantity( 40' Container )		unit	222	126	126	126
Loading Quantity ( 40' High Cube Container )		unit	246	154	154	154

### 3.Cassette type:

Model	FP-8XD-E	FP-10XD-E	FP-12.5XD-E
Function	COOLING		
Power Supply(V-Ph-Hz)	230V~ 50Hz		
Total Capacity (W)	4600	5400	6700
Power Input (W)	110		
Rated Input (W)	110		
Rated Current (A)	0.75		
Air Flow Volume (m <sup>3</sup> /h) (H/M/L)	850/638/515	1020/788/615	1270/1030/916
Fan Motor Speed (r/min) (H/M/L)	590/563/520	631/590/560	591/510/480
Output of Fan Motor (w)	35		
Input of Heater (w)	1510		
Fan Type-Piece	Centrifugal - 1		
Diameter-Length (mm)	φ 450X 141		
Evaporator	Aluminum fin-copper tube		
Dimension of Water Pipe(mm)	φ 7		
Row-Fin Gap(mm)	2-1.5		
Coil (L×H×W) (mm)	1900X1715X254	1900X1715X254	1900X248X254
Fuse (A)	PCB 3.15A Transformer 0.2A		
Sound Pressure Level dB (A) (H/M/L)	42/41/40	43/42/40	53/52/51
Outline Dimension (W×D×H) ( mm)	Body	840X840X240	
	Panel	960X960X60	
Package Dimension (W×D×H) ( mm)	Body	960X960X310	
	Panel	1025X1040X115	
N.W/G.W (body) (kg)	30/38		
N.W/G.W (Panel) (kg)	6.5/10		
Loading Quantity ( 20' Container ) (unit)	84	84	84
Loading Quantity ( 40' Container ) (unit)	168	168	168
Loading Quantity ( 40'High Cube Container ) (unit)	192	192	192

# FAN COIL UNIT TECHNICAL SALES GUIDE

Model	FP-14XD-E	FP-16XD-E	FP-18XD-E
Function	COOLING		
Power Supply(V-Ph-Hz)	230V~ 50Hz		
Total Capacity (W)	7700	8700	9600
Power Input (W)	145	150	160
Rated Input (W)	160	150	160
Rated Current (A)	0.75	0.75	0.75
Air Flow Volume (m <sup>3</sup> /h) (H/M/L)	1560/1364/1198	1640/1450/1327	1850/1760/1586
Fan Motor Speed (r/min) (H/M/L)	695/650/620	745/709/660	769//731/683
Output of Fan Motor (w)	50		
Input of Heater (w)	1550		
Fan Type-Piece	Centrifugal - 1		
Diameter-Length (mm)	φ 450X 169.5		
Evaporator	Aluminum fin-copper tube		
Dimension of Water Pipe(mm)	φ 7		
Row-Fin Gap(mm)	2-1.5		
Coil (L×H×W) (mm)	1900X171.5X25.4	1900X248X25.4	1900X248X25.4
Fuse (A)	PCB 3.15A Transformer 0.2A		
Sound Pressure Level dB (A) (H/M/L)	53/52/51	53/52/51	54/52/51
Outline Dimension (WXDXH) (mm)	Body	840X840X320	
	Panel	960X960X60	
Package Dimension (WXDXH) (mm)	Body	960X960X394	
	Panel	1025X1040X115	
N.W/G.W(Body) (kg)	38/46		
N.W/G.W (Panel) (kg)	6.5/10		
Loading Quantity( 20' Container ) (unit)	60	60	60
Loading Quantity( 40' Container ) (unit)	120	120	120
Loading Quantity ( 40'High Cube Container ) (unit)	144	144	144

#### 4. Wall mounted

MODEL			FP-34BA2/A-K	FP-51BA2/A-K	FP-68BA2/A-K	FP-85BA2/A-K	
Performance	Nominal	High	m <sup>3</sup> /h	360	550	680	850
			CFM	212	324	400	501
	Air Flow	Medium	m <sup>3</sup> /h	320	410	590	680
			CFM	188	241	347	400
		Low	m <sup>3</sup> /h	280	270	520	590
			CFM	165	159	306	347
	Nominal Capacity	Cooling	kW	2.1	2.7	3.6	4.2
			Btu/h	7203	9261	12348	14406
		Heating	kW	3.15	4.05	5.4	6.3
			Btu/h	10805	13892	18522	21609
	Water Flow Volume		m <sup>3</sup> /h	0.4	0.45	0.6	0.7
			G.P.M.(US)	1.756	1.976	2.634	3.073
Water Pressure Drop		KPa	25	30	30	35	
		ft.wg.	8.33	10	10	11.66	
Sound Pressure Level		dB. (A)	35	40	43	48	
Coil	Face Area	sq.m	0.16	0.16	0.18	0.18	
	Face Velocity	m/s	0.85	1.08	1.05	1.31	
Motor	Type	—	Isolation B Capacitor startup three-speed Motor				
	No. of Motor	—	1				
	Power Supply	—	220-240V~ 1Ph 50Hz				
Fan	Type	—	Forward multi-vane low noise centrifugal fan				
	No. of Fans	—	1				
Screw thread connection	Water in/out Pipe	inch	1/2"				
	Condensate Pipe	inch	1/4"				
Net/Gross Weight		kg	11/14		13/17		

**Note:**

- The water working temperature is from 7°C(44.6°F) to 60°C(140°F).
- The temperature exchange efficiency and enthalpy exchange efficiency are tested under these testing conditions as below:
  - Cooling efficiency: air 27°C(80.6°F) DB, 19.5°C(67.1°F) WB, water temperature in 7°C(44.6°F), water out 12°C(53.6°F).
  - Heating efficiency: air 21°C(69.8°F) DB, Water temperature: 60°C(140°F).
- Sound power level according to ISO 5151-sound pressure calculated at 1m distance.

# FAN COIL UNIT TECHNICAL SALES GUIDE

MODEL			FP-51WBA2/A-K	FP-85WA2/A-K		
Performance	Nominal	High	m <sup>3</sup> /h	450	650	
			CFM	265	382	
	Air Flow	Medium	m <sup>3</sup> /h	380	560	
			CFM	224	329	
		Low	m <sup>3</sup> /h	320	490	
			CFM	188	288	
	Nominal Capacity	Cooling	kW	1.5	2.4	
			Btu/h	5118	8189	
		Heating	kW	2.25	3.6	
			Btu/h	7677	12283	
	Water Flow Volume			m <sup>3</sup> /h	0.28	0.38
				G.P.M.(US)	1.223	5.369
	Water Pressure Drop			KPa	20	35
		ft.wg.	6.67	11.67		
Sound Pressure Level			dB. (A)	42	50	
Coil	Face Area		sq.m	0.12	0.14	
	Face Velocity		m/s	1.04	1.29	
Motor	Type		—	Isolation B Capacitor startup three-speed Motor		
	No. of Motor		—	1		
	Power Supply		—	220-240V~ 1Ph 50Hz		
Fan	Type		—	Forward multi-vane low noise centrifugal fan		
	No. of Fans		—	1		
Screw thread connection	Water in/out Pipe		inch	1/2"		
	Condensate Pipe		inch	1/4"		
Net/Gross Weight			kg	11/14	13/17	

**Note:**

- The water working temperature is from 7°C(44.6°F) to 60°C(140°F).
- The temperature exchange efficiency and enthalpy exchange efficiency are tested under these testing conditions as below:
  - Cooling efficiency: air 27°C(80.6°F) DB, 19.5°C(67.1°F) WB, water temperature in 7°C(44.6°F), water out 12°C(53.6°F).
  - Heating efficiency: air 21°C(69.8°F) DB, Water temperature: 60°C(140°F).
- Sound power level according to ISO 5151-sound pressure calculated at 1m distance.

## 8 PERFORMANCE RATING

### 8.1 Cooling performance rating

#### 8.1.1 Ceiling concealed—Standard

Model	EWT °C	Entering Air Temperature															
		DB23°C WB16°C				DB25°C WB18°C				DB27°C WB19°C				DB29°C WB22°C			
		TH	SH	Water Flow l/s	Water Resistance KPa	TH	SH	Water Flow l/s	Water Resistance KPa	TH	SH	Water Flow l/s	Water Resistance KPa	TH	SH	Water Flow l/s	Water Resistance KPa
34	5	1380	1040	0.07	12	1804	1209	0.09	15	2110	1372	0.1	16	2662	1442	0.13	23
	6	1286	1007	0.06	9	1669	1161	0.08	12	1943	1313	0.09	13	2489	1383	0.12	18
	7	1197	972	0.06	8	1569	1130	0.07	10	1850	1290	0.09	12	2309	1325	0.11	15
	8	1032	889	0.05	5	1358	1033	0.06	7	1630	1202	0.08	10	2129	1272	0.1	11
	9	929	828	0.04	4	1229	983	0.06	5	1497	1150	0.07	8	1956	1214	0.09	9
51	5	2089	1629	0.1	21	2730	1893	0.13	27	3193	2148	0.15	28	4029	2258	0.19	40
	6	1946	1577	0.09	16	2526	1819	0.12	21	2941	2057	0.14	23	3767	2166	0.18	31
	7	1812	1523	0.09	14	2374	1769	0.11	18	2800	2020	0.13	21	3495	2075	0.17	26
	8	1563	1391	0.07	9	2056	1617	0.1	12	2468	1883	0.12	17	3223	1993	0.15	19
	9	1406	1296	0.07	7	1861	1540	0.09	10	2266	1801	0.11	14	2961	1901	0.14	15
68	5	2686	2218	0.13	16	3510	2578	0.17	20	4105	2924	0.2	21	5180	3074	0.25	30
	6	2502	2146	0.12	12	3248	2476	0.16	16	3781	2800	0.18	18	4843	2949	0.23	24
	7	2330	2073	0.11	10	3053	2408	0.15	14	3600	2750	0.17	16	4494	2825	0.21	20
	8	2009	1894	0.1	7	2643	2201	0.13	9	3173	2563	0.15	13	4144	2713	0.2	15
	9	1808	1764	0.09	6	2392	2096	0.11	7	2914	2451	0.14	11	3807	2588	0.18	12
85	5	3357	2750	0.16	22	4387	3196	0.21	29	5131	3626	0.24	30	6475	3811	0.31	43
	6	3128	2661	0.15	18	4060	3070	0.19	23	4727	3472	0.23	25	6054	3657	0.29	34
	7	2912	2571	0.14	15	3816	2986	0.18	20	4500	3410	0.21	23	5617	3503	0.27	29
	8	2511	2349	0.12	10	3304	2730	0.16	13	3966	3179	0.19	18	5180	3364	0.25	21
	9	2260	2188	0.11	8	2990	2600	0.14	11	3642	3040	0.17	16	4759	3209	0.23	17
102	5	4103	3387	0.2	35	5362	3937	0.26	46	6272	4466	0.3	47	7914	4694	0.38	68
	6	3823	3278	0.18	28	4962	3782	0.24	36	5777	4276	0.28	40	7399	4504	0.35	53
	7	3560	3166	0.17	23	4664	3678	0.22	31	5500	4200	0.26	36	6865	4314	0.33	45
	8	3069	2893	0.15	16	4038	3362	0.19	21	4847	3915	0.23	29	6331	4143	0.3	33
	9	2762	2695	0.13	12	3655	3202	0.17	16	4451	3744	0.21	25	5817	3953	0.28	26
136	5	5484	4636	0.26	37	7166	5388	0.34	49	8381	6113	0.4	50	10576	6425	0.5	72
	6	5109	4487	0.24	29	6632	5176	0.32	38	7720	5853	0.37	42	9888	6165	0.47	56
	7	4757	4334	0.23	25	6233	5035	0.3	32	7350	5749	0.35	38	9174	5905	0.44	47
	8	4102	3960	0.2	17	5396	4602	0.26	22	6478	5359	0.31	30	8460	5671	0.4	35
	9	3691	3689	0.18	13	4884	4383	0.23	17	5949	5125	0.28	26	7773	5411	0.37	28
170	5	6864	5908	0.33	37	8970	6867	0.43	49	10491	7791	0.5	50	13237	8189	0.63	72
	6	6395	5719	0.31	29	8301	6597	0.4	38	9663	7460	0.46	42	12377	7857	0.59	56
	7	5954	5523	0.28	25	7802	6417	0.37	32	9200	7327	0.44	38	11483	7526	0.55	47
	8	5134	5047	0.25	17	6754	5865	0.32	22	8108	6830	0.39	30	10590	7228	0.51	35
	9	4620	4701	0.22	13	6113	5586	0.29	17	7446	6531	0.36	26	9730	6896	0.46	28
204	5	8207	6856	0.39	39	10724	7969	0.51	51	12543	9041	0.6	52	15827	9502	0.76	75
	6	7646	6636	0.36	31	9925	7655	0.47	40	11554	8656	0.55	44	14799	9118	0.71	59
	7	7119	6409	0.34	26	9328	7446	0.45	34	11000	8502	0.53	40	13730	8733	0.66	50
	8	6138	5857	0.29	18	8075	6806	0.39	23	9694	7925	0.46	32	12662	8387	0.6	37
	9	5524	5455	0.26	14	7309	6481	0.35	18	8903	7579	0.42	28	11633	8002	0.56	29

Note:

- 1.TH:Total Cooling Capacity; SH:Sensible Cooling Capacity;
- 2.DB: Entering Air Dry - bulb Temperature; WB:Entering Air Wet - bulb Temperature.
3. Fan Speed =High Under Dry Coil Conditions at 12 Pa External Static Pressure



## 8.1.2 Cassette Type

Model	EWT °C	Entering Air Temperature															
		DB23°C WB16°C				DB25°C WB18°C				DB27°C WB19°C				DB29°C WB22°C			
		TH	SH	Water Flow l/s	Water Resistance KPa	TH	SH	Water Flow l/s	Water Resistance KPa	TH	SH	Water Flow l/s	Water Resistance KPa	TH	SH	Water Flow l/s	Water Resistance KPa
8	5	3462	2900	0.17	15	4524	3370	0.22	19	5291	3824	0.25	20	6676	4019	0.32	28
	6	3225	2807	0.15	12	4186	3238	0.2	15	4874	3661	0.23	17	6242	3856	0.3	22
	7	3003	2711	0.14	10	3935	3149	0.19	13	4640	3596	0.22	15	5792	3694	0.28	19
	8	2589	2477	0.12	7	3406	2879	0.16	9	4089	3352	0.2	12	5341	3547	0.25	14
	9	2330	2307	0.11	5	3083	2741	0.15	7	3755	3205	0.18	10	4907	3384	0.23	11
10	5	4029	3309	0.19	24	5265	3847	0.25	32	6158	4364	0.29	33	7770	4587	0.37	47
	6	3754	3203	0.18	19	4872	3695	0.23	25	5672	4178	0.27	28	7265	4401	0.35	37
	7	3495	3094	0.17	16	4579	3594	0.22	21	5400	4104	0.26	25	6740	4215	0.32	31
	8	3013	2827	0.14	11	3964	3285	0.19	15	4759	3825	0.23	20	6216	4048	0.3	23
	9	2712	2633	0.13	9	3588	3129	0.17	11	4371	3658	0.21	17	5711	3863	0.27	18
12.5	5	4999	4106	0.24	23	6532	4773	0.31	31	7640	5415	0.36	31	9640	5691	0.46	45
	6	4657	3974	0.22	18	6045	4585	0.29	24	7037	5184	0.34	26	9014	5461	0.43	36
	7	4336	3839	0.21	16	5682	4459	0.27	20	6700	5092	0.32	24	8363	5230	0.4	30
	8	3739	3508	0.18	11	4919	4076	0.23	14	5905	4746	0.28	19	7712	5023	0.37	22
	9	3365	3267	0.16	8	4452	3882	0.21	11	5423	4539	0.26	17	7086	4792	0.34	18
14	5	5775	4743	0.28	28	7546	5513	0.36	37	8826	6255	0.42	38	11137	6574	0.53	55
	6	5380	4591	0.26	22	6983	5296	0.33	29	8130	5989	0.39	32	10413	6308	0.5	43
	7	5009	4434	0.24	19	6564	5152	0.31	25	7740	5882	0.37	29	9661	6042	0.46	36
	8	4319	4052	0.21	13	5682	4709	0.27	17	6821	5483	0.33	23	8909	5803	0.43	26
	9	3887	3774	0.19	10	5143	4484	0.25	13	6264	5244	0.3	20	8185	5536	0.39	21
16	5	6491	5332	0.31	21	8482	6197	0.4	27	9921	7031	0.47	28	12518	7390	0.6	40
	6	6048	5161	0.29	16	7850	5953	0.37	21	9138	6732	0.44	23	11704	7091	0.56	31
	7	5631	4984	0.27	14	7378	5791	0.35	18	8700	6612	0.42	21	10859	6792	0.52	26
	8	4855	4555	0.23	9	6387	5293	0.3	12	7667	6163	0.37	17	10014	6522	0.48	19
	9	4369	4242	0.21	7	5781	5041	0.28	10	7041	5894	0.34	14	9201	6223	0.44	15
18	5	7162	5883	0.34	22	9359	6838	0.45	29	10947	7758	0.52	30	13813	8154	0.66	43
	6	6673	5694	0.32	18	8662	6569	0.41	23	10083	7428	0.48	25	12915	7824	0.62	34
	7	6213	5500	0.3	15	8141	6390	0.39	20	9600	7296	0.46	23	11983	7494	0.57	29
	8	5357	5026	0.26	10	7048	5840	0.34	13	8460	6801	0.4	18	11050	7197	0.53	21
	9	4821	4681	0.23	8	6379	5562	0.3	11	7770	6504	0.37	16	10153	6867	0.48	17

Note:

- 1.TH:Total Cooling Capacity; SH:Sensible Cooling Capacity;
- 2.DB: Entering Air Dry - bulb Temperature; WB:Entering Air Wet - bulb Temperature.
3. Fan Speed =High Under Dry Coil Conditions .

### 8.1.3 Wall Mounted Type fan coil unit cooling capacity correct coefficient

FP-34BA2/A-K、FP-51BA2/A-K

Model	Suction Water temp °C(°F)	Suction Air temp								
		DB24°C (75.2°F)			DB25°C (77°F)			DB26°C (78.8°F)		
		WB17°C (62.6°F)			WB18°C (64.4°F)			WB19°C (66.2°F)		
		TH (W)	Water Flow Volume (L/s)	Water Pressure Drop (Kpa)	TH (W)	Water Flow Volume (L/s)	Water Pressure Drop (Kpa)	TH (W)	Water Flow Volume (L/s)	Water Pressure Drop (Kpa)
FP-34BA2/A-K	5(41)	1765	0.084	16.68	2012	0.096	22.96	2269	0.109	29.19
	6(42.8)	1612	0.077	14.74	1859	0.089	19.59	2115	0.101	25.38
	7(44.6)	1459	0.07	12.06	1705	0.082	16.49	1962	0.094	21.83
	8(46.4)	1305	0.062	9.66	1552	0.074	13.65	1809	0.087	18.55
	9(48.2)	1152	0.055	7.52	1398	0.067	11.09	1655	0.079	15.53
	Suction Water temp °C(°F)	DB27°C (62.6°F)			DB28°C (82.4°F)			DB30°C (86°F)		
		WB17°C (62.2°F)			WB21°C (69.8°F)			WB22°C (71.6°F)		
		TH (W)	Water Flow Volume (L/s)	Water Pressure Drop (Kpa)	TH (W)	Water Flow Volume (L/s)	Water Pressure Drop (Kpa)	TH (W)	Water Flow Volume (L/s)	Water Pressure Drop (Kpa)
	5(41)	2400	0.115	32.68	2815	0.135	44.93	3104	0.149	54.61
	6(42.8)	2247	0.108	28.63	2662	0.127	40.16	2950	0.141	49.34
7(44.6)	2100	0.102	25	2508	0.12	35.66	2797	0.134	44.34	
8(46.4)	1940	0.093	21.35	2355	0.113	31.43	2643	0.126	39.6	
9(48.2)	1787	0.086	18.1	2201	0.105	27.47	2490	0.119	35.14	
Model	Suction Water temp °C(°F)	Suction Air temp								
		DB24°C (75.2°F)			DB25°C (77°F)			DB26°C (78.8°F)		
		WB17°C (62.2°F)			WB18°C (64.4°F)			WB19°C (66.2°F)		
		TH (W)	Water Flow Volume (L/s)	Water Pressure Drop (Kpa)	TH (W)	Water Flow Volume (L/s)	Water Pressure Drop (Kpa)	TH (W)	Water Flow Volume (L/s)	Water Pressure Drop (Kpa)
FP-51BA2/A-K	5(41)	2270	0.109	21.21	2587	0.124	27.55	2981	0.14	35.03
	6(42.8)	2073	0.099	17.69	2390	0.114	23.51	2720	0.13	30.46
	7(44.6)	1876	0.09	14.48	2193	0.105	19.79	2523	0.121	26.2
	8(46.4)	1678	0.08	11.59	1995	0.095	16.38	2326	0.111	22.26
	9(48.2)	1481	0.071	9.03	1798	0.086	13.3	2128	0.102	18.64
	Suction Water temp °C(°F)	DB27°C (62.6°F)			DB28°C (82.4°F)			DB30°C (86°F)		
		WB19.5°C (67.1°F)			WB21°C (69.8°F)			WB22°C (71.6°F)		
		TH (W)	Water Flow Volume (L/s)	Water Pressure Drop (Kpa)	TH (W)	Water Flow Volume (L/s)	Water Pressure Drop (Kpa)	TH (W)	Water Flow Volume (L/s)	Water Pressure Drop (Kpa)
	5(41)	3087	0.148	39.22	3619	0.173	53.29	3990	0.19	65.53
	6(42.8)	2889	0.138	34.26	3422	0.164	48.2	3793	0.181	59.21
7(44.6)	2700	0.129	30	3225	0.154	42.8	3596	0.172	53.2	
8(46.4)	2495	0.119	25.61	3027	0.145	37.72	3398	0.163	47.52	
9(48.2)	2298	0.11	21.72	2830	0.135	32.96	3201	0.153	42.16	

Note: In this table, The temperature of the out canal is higher 5°C than the canal which water in.

# FAN COIL UNIT TECHNICAL SALES GUIDE

## FP-68BA2/A-K、FP-85BA2/A-K

Model	Suction Water temp °C(°F)	Suction Air temp								
		DB24°C (75.2°F)			DB25°C (77°F)			DB26°C (78.8°F)		
		WB17°C (62.6°F)			WB18°C (64.4°F)			WB19°C (66.2°F)		
TH (W)	Water Flow Volume (L/s)	Water Pressure Drop (Kpa)	TH (W)	Water Flow Volume (L/s)	Water Pressure Drop (Kpa)	TH (W)	Water Flow Volume (L/s)	Water Pressure Drop (Kpa)		
FP-68BA2/A-K	5(41)	3027	0.145	21.12	3450	0.165	27.55	3890	0.186	35.03
	6(42.8)	2764	0.132	17.69	3187	0.152	23.51	3627	0.174	30.46
	7(44.6)	2501	0.12	14.48	2923	0.14	19.79	3364	0.161	26.2
	8(46.4)	2238	0.107	11.57	2660	0.127	16.38	3101	0.148	22.26
	9(48.2)	1975	0.094	9.03	2379	0.115	13.3	2838	0.136	18.64
	Suction Water temp °C(°F)	DB27°C (62.6°F)			DB28°C (82.4°F)			DB30°C (86°F)		
		WB19.5°C (67.1°F)			WB21°C (69.8°F)			WB22°C (71.6°F)		
	TH (W)	Water Flow Volume (L/s)	Water Pressure Drop (Kpa)	TH (W)	Water Flow Volume (L/s)	Water Pressure Drop (Kpa)	TH (W)	Water Flow Volume (L/s)	Water Pressure Drop (Kpa)	
	5(41)	4116	0.197	39.22	4826	0.231	53.92	5320	0.255	65.53
	6(42.8)	3853	0.184	34.36	4562	0.218	48.19	5057	0.242	59.2
	7(44.6)	3600	0.172	29.83	4299	0.206	42.79	4794	0.229	53.2
	8(46.4)	3327	0.159	25.61	4036	0.193	37.72	4531	0.217	47.52
	9(48.2)	3063	0.147	21.72	3773	0.181	32.96	4267	0.204	42.16
	Model	Suction Water temp °C(°F)	Suction Air temp							
DB24°C (75.2°F)			DB25°C (77°F)			DB26°C (78.8°F)				
WB17°C (62.6°F)			WB18°C (64.4°F)			WB19°C (66.2°F)				
TH (W)	Water Flow Volume (L/s)	Water Pressure Drop (Kpa)	TH (W)	Water Flow Volume (L/s)	Water Pressure Drop (Kpa)	TH (W)	Water Flow Volume (L/s)	Water Pressure Drop (Kpa)		
FP-85BA2/A-K	5(41)	3532	0.169	24.74	4024	0.193	32.14	4538	0.217	40.87
	6(42.8)	3225	0.154	20.63	3718	0.178	27.43	4231	0.202	35.53
	7(44.6)	2918	0.139	16.89	3410	0.163	23.08	3925	0.188	30.56
	8(46.4)	2611	0.125	13.52	3104	0.149	19.11	3618	0.173	25.97
	9(48.2)	2303	0.11	10.53	2797	0.134	15.52	3310	0.158	21.75
	Suction Water temp °C(°F)	DB27°C (62.6°F)			DB28°C (82.4°F)			DB30°C (86°F)		
		WB19.5°C (67.1°F)			WB21°C (69.8°F)			WB22°C (71.6°F)		
	TH (W)	Water Flow Volume (L/s)	Water Pressure Drop (Kpa)	TH (W)	Water Flow Volume (L/s)	Water Pressure Drop (Kpa)	TH (W)	Water Flow Volume (L/s)	Water Pressure Drop (Kpa)	
	5(41)	4801	0.23	45.75	5630	0.269	62.9	6207	0.297	76.45
	6(42.8)	4495	0.215	40.08	5323	0.255	56.23	5900	0.282	69.07
	7(44.6)	4200	0.2	34.8	5016	0.24	49.93	5593	0.268	62.07
	8(46.4)	3881	0.186	29.88	4709	0.225	44.01	5286	0.253	55.45
	9(48.2)	3574	0.171	25.34	4402	0.211	38.45	4979	0.238	49.19

FP-51BWA2/A-K、FP-85BWA2/A-K

Model	Suction Water temp °C(°F)	Suction Air temp								
		DB24°C (75.2°F)			DB25°C (77°F)			DB26°C (78.8°F)		
		WB17°C (62.6°F)			WB18°C (64.4°F)			WB19°C (66.2°F)		
	TH (W)	Water Flow Volume (L/s)	Water Pressure Drop (Kpa)	TH (W)	Water Flow Volume (L/s)	Water Pressure Drop (Kpa)	TH (W)	Water Flow Volume (L/s)	Water Pressure Drop (Kpa)	
FP-51BWA2/A-K	5(41)	1261	0.06	14.14	1437	0.069	18.37	1620	0.087	23.36
	6(42.8)	1152	0.055	11.73	1328	0.064	15.67	1511	0.072	20.3
	7(44.6)	1042	0.05	9.65	1218	0.058	13.19	1402	0.067	17.46
	8(46.4)	932	0.045	7.73	1109	0.053	10.92	1292	0.062	14.84
	9(48.2)	823	0.039	6.02	1000	0.048	8.87	1182	0.057	12.43
	Suction Water temp °C(°F)	DB27°C (62.6°F)			DB28°C (82.4°F)			DB30°C (86°F)		
		WB19.5°C (67.1°F)			WB21°C (69.8°F)			WB22°C (71.6°F)		
		TH (W)	Water Flow Volume (L/s)	Water Pressure Drop (Kpa)	TH (W)	Water Flow Volume (L/s)	Water Pressure Drop (Kpa)	TH (W)	Water Flow Volume (L/s)	Water Pressure Drop (Kpa)
	5(41)	1715	0.082	26.14	2010	0.096	35.94	2216	0.106	43.69
	6(42.8)	1605	0.077	22.9	1901	0.09	32.13	2107	0.101	39.47
7(44.6)	1496	0.072	19.89	1792	0.086	28.53	1998	0.096	35.47	
8(46.4)	1386	0.066	17.07	1682	0.08	25.15	1888	0.09	31.68	
9(48.2)	1276	0.061	14.48	1572	0.075	21.97	1778	0.085	28.11	
Model	Suction Water temp °C(°F)	Suction Air temp								
		DB24°C (75.2°F)			DB25°C (77°F)			DB26°C (78.8°F)		
		WB17°C (62.6°F)			WB18°C (64.4°F)			WB19°C (66.2°F)		
	TH (W)	Water Flow Volume (L/s)	Water Pressure Drop (Kpa)	TH (W)	Water Flow Volume (L/s)	Water Pressure Drop (Kpa)	TH (W)	Water Flow Volume (L/s)	Water Pressure Drop (Kpa)	
FP-85BWA2/A-K	5(41)	2018	0.097	24.75	2300	0.11	32.14	2594	0.124	40.87
	6(42.8)	1843	0.088	20.63	2124	0.102	27.43	2418	0.116	35.53
	7(44.6)	1667	0.08	16.89	1949	0.093	23.08	2243	0.107	30.56
	8(46.4)	1492	0.072	13.53	1774	0.085	19.11	2067	0.099	25.97
	9(48.2)	1316	0.063	10.53	1598	0.076	15.52	1892	0.091	21.75
	Suction Water temp °C(°F)	DB27°C (62.6°F)			DB28°C (82.4°F)			DB30°C (86°F)		
		WB19.5°C (67.1°F)			WB21°C (69.8°F)			WB22°C (71.6°F)		
		TH (W)	Water Flow Volume (L/s)	Water Pressure Drop (Kpa)	TH (W)	Water Flow Volume (L/s)	Water Pressure Drop (Kpa)	TH (W)	Water Flow Volume (L/s)	Water Pressure Drop (Kpa)
	5(41)	2744	0.131	45.75	3217	0.154	62.9	3547	0.17	76.45
	6(42.8)	2569	0.123	40.09	3042	0.146	56.23	3372	0.161	69.07
7(44.6)	2393	0.115	34.8	2867	0.137	49.93	3196	0.153	62.07	
8(46.4)	2218	0.106	29.88	2691	0.129	44.01	3021	0.145	55.45	
9(48.2)	2042	0.098	25.34	2516	0.12	38.45	2845	0.136	49.19	

8.1.4 Floor And Ceiling Type fan coil unit cooling capacity correct coefficient

rating		FP-34	FP-51	FP-68	FP-85	FP-102	FP-136	FP-170	FP-204
TH	WM	1.07	1.05	1.06	1.03	1.02	1.01	0.99	0.99
SH		1.06	1.03	1.05	1.02	1.01	1	0.98	0.98

## 8.2 Heating performance rating

### 8.2.1 Ceiling concealed — Standard

Model	EWT °C	Entering Air Temperature								
		DB21°C			DB20°C			DB19°C		
		Total Heating Capacity W	Water Flow l/s	Water Resistance KPa	Total Heating Capacity W	Water Flow l/s	Water Resistance KPa	Total Heating Capacity W	Water Flow l/s	Water Resistance KPa
34	45	1895	0.09	18	1956	0.09	22	1996	0.1	25
	50	2119	0.05	6	2172	0.05	7	2223	0.05	9
	60	3050	0.07	12	3123	0.07	13	3181	0.08	14
	70	3877	0.09	18	3916	0.09	20	4024	0.1	21
51	45	2734	0.13	32	2822	0.14	38	2879	0.14	44
	50	3058	0.07	11	3134	0.07	13	3207	0.08	15
	60	4400	0.1	21	4506	0.11	24	4589	0.11	25
	70	5593	0.13	32	5649	0.13	34	5806	0.14	36
68	45	3418	0.16	24	3527	0.17	29	3599	0.17	34
	50	3822	0.09	8	3917	0.09	10	4009	0.1	12
	60	5500	0.13	16	5632	0.13	18	5736	0.14	19
	70	6992	0.17	24	7061	0.17	26	7257	0.17	28
85	45	4350	0.21	35	4489	0.22	41	4581	0.22	48
	50	4864	0.12	12	4986	0.12	14	5102	0.12	17
	60	7000	0.17	23	7168	0.17	26	7301	0.17	28
	70	8898	0.21	35	8987	0.21	37	9236	0.22	40
102	45	5531	0.27	54	5708	0.27	65	5824	0.28	76
	50	6185	0.15	18	6339	0.15	22	6487	0.15	26
	60	8900	0.21	36	9114	0.22	40	9282	0.22	43
	70	11314	0.27	54	11427	0.27	59	11743	0.28	62
136	45	6836	0.33	57	7055	0.34	68	7198	0.35	80
	50	7644	0.18	19	7834	0.19	23	8018	0.19	28
	60	11000	0.26	38	11265	0.27	43	11472	0.27	46
	70	13983	0.33	57	14123	0.34	62	14514	0.34	65
170	45	8701	0.42	57	8979	0.43	68	9162	0.44	80
	50	9729	0.23	19	9971	0.24	23	10204	0.24	28
	60	14000	0.33	38	14337	0.34	43	14601	0.35	46
	70	17797	0.42	57	17975	0.43	62	18473	0.44	65
204	45	10565	0.51	60	10903	0.52	72	11125	0.53	84
	50	11814	0.28	20	12108	0.29	24	12391	0.29	29
	60	17000	0.4	40	17409	0.41	45	17730	0.42	48
	70	21610	0.51	60	21826	0.52	65	22431	0.53	69

### 8.2.2 Cassette Type

Model	EWT °C	Entering Air Temperature								
		DB21°C			DB20°C			DB19°C		
		Total Heating Capacity W	Water Flow l/s	Water Resistance KPa	Total Heating Capacity W	Water Flow l/s	Water Resistance KPa	Total Heating Capacity W	Water Flow l/s	Water Resistance KPa
8	45	4661	0.22	23	4810	0.23	27	4908	0.24	32
	50	5212	0.12	8	5342	0.13	9	5467	0.13	11
	60	7500	0.18	15	7681	0.18	17	7822	0.19	18
	70	9534	0.23	23	9629	0.23	24	9896	0.23	26
10	45	5655	0.27	38	5836	0.28	45	5955	0.29	53
	50	6324	0.15	13	6481	0.15	15	6633	0.16	18
	60	9100	0.22	25	9319	0.22	28	9491	0.23	30
	70	11568	0.27	38	11683	0.28	41	12007	0.28	43
12.5	45	6525	0.31	36	6734	0.32	43	6871	0.33	50
	50	7297	0.17	12	7478	0.18	14	7653	0.18	18
	60	10500	0.25	24	10753	0.26	27	10951	0.26	29
	70	13347	0.32	36	13481	0.32	39	13855	0.33	41
14	45	6960	0.33	44	7183	0.35	52	7329	0.35	61
	50	7783	0.18	15	7977	0.19	17	8163	0.19	21
	60	11200	0.27	29	11470	0.27	32	11681	0.28	35
	70	14237	0.34	44	14380	0.34	47	14778	0.35	50
16	45	8017	0.39	32	8273	0.4	38	8442	0.41	44
	50	8964	0.21	11	9188	0.22	13	9403	0.22	15
	60	12900	0.31	21	13210	0.31	24	13454	0.32	25
	70	16398	0.39	32	16562	0.39	34	17021	0.4	36
18	45	9073	0.44	35	9364	0.45	41	9554	0.46	48
	50	10146	0.24	12	10398	0.25	14	10642	0.25	17
	60	14600	0.35	23	14951	0.35	26	15227	0.36	28
	70	18559	0.44	35	18745	0.44	37	19265	0.46	40

Note:

- 1.The temperature difference of in/outlet water is 5°C when the water inlet temperature is 45°C, otherwise the temperature difference will be 10°C
- 2.The table above just shows the heating capacity when the units run at high speed and 12Pa external static pressure (without air in/outlet and filter)
- 3.If the fan coil units run at other speed and air flow volume,please multiply the coefficient separately showed in below curve diagram.

rating	series	FP-34	FP-51	FP-68	FP-85	FP-102	FP-136	FP-170	FP-204
TH	WM	1.07	1.05	1.06	1.03	1.02	1.01	0.99	0.99

### Curve for capacity on medium or low Fan speed

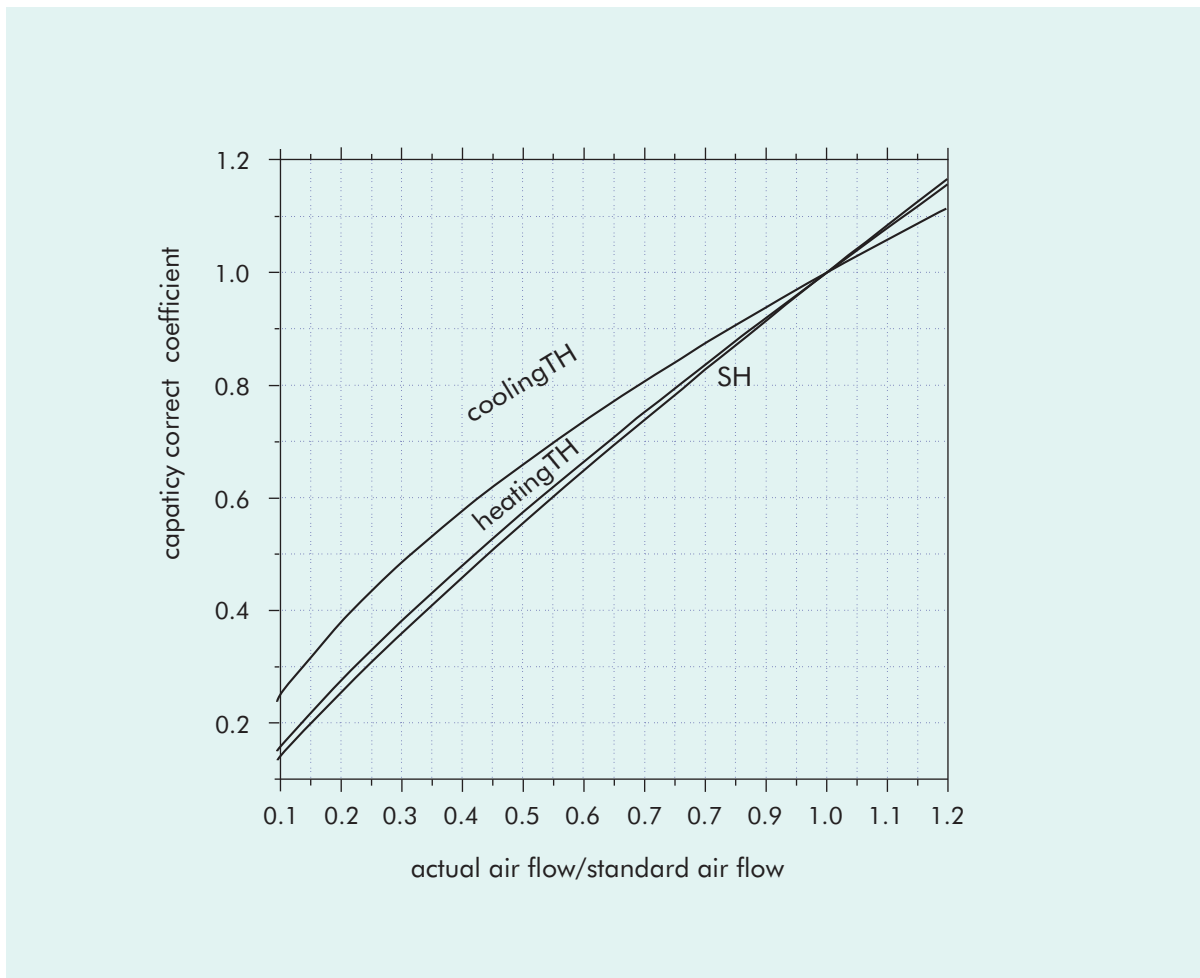

## 8.1.3 Wall Mounted Type fan coil unit cooling capacity correct coefficient

Model	Suction Water temp °C(°F)	Entering Air Temperature								
		DB21°C (69.8°F)			DB20°C (68°F)			DB19°C (66.2°F)		
		TH (W)	Water Flow Volume (L/s)	Water Pressure Drop (Kpa)	TH (W)	Water Flow Volume (L/s)	Water Pressure Drop (Kpa)	TH (W)	Water Flow Volume (L/s)	Water Pressure Drop (Kpa)
FP-34BA2/A-K	45(113°F)	2394	0.029	14.44	2687	0.032	18.18	2970	0.036	22.23
	50(113°F)	2641	0.032	17.58	2934	0.035	26.69	3218	0.038	26.08
	60(113°F)	3135	0.038	24.78	3428	0.041	29.61	3712	0.044	34.72
	70(113°F)	3630	0.043	33.2	3923	0.047	38.77	4207	0.05	44.59
FP-51BA2/A-K	45(113°F)	3078	0.037	17.33	3454	0.041	21.82	3819	0.046	26.67
	50(113°F)	3396	0.041	21.09	3772	0.045	26.02	4137	0.049	31.3
	60(113°F)	4032	0.048	29.73	4408	0.053	35.54	4773	0.057	41.66
	70(113°F)	4668	0.056	39.85	5044	0.06	46.53	5409	0.065	53.5
FP-68BA2/A-K	45(113°F)	4104	0.049	17.33	4605	0.055	21.82	5092	0.061	26.67
	50(113°F)	4528	0.054	21.09	5029	0.06	26.02	5516	0.066	31.3
	60(113°F)	5376	0.064	29.73	5877	0.07	35.54	6364	0.076	41.66
	70(113°F)	6223	0.074	39.85	6725	0.08	46.53	7211	0.086	53.5
FP-85BA2/A-K	45(113°F)	4788	0.057	20.22	5373	0.064	25.46	5940	0.071	31.12
	50(113°F)	5283	0.063	24.61	5868	0.07	30.36	6435	0.077	36.52
	60(113°F)	6272	0.075	34.69	6857	0.082	41.46	7424	0.089	48.61
	70(113°F)	7260	0.087	46.49	7846	0.094	54.28	8413	0.101	62.42
FP-51BWA2/A-K	45(113°F)	1710	0.021	11.55	1919	0.023	14.55	2122	0.025	17.78
	50(113°F)	1887	0.023	14.06	2096	0.025	19.35	2298	0.027	20.87
	60(113°F)	2240	0.027	19.82	2449	0.029	23.69	2651	0.032	27.77
	70(113°F)	2593	0.031	26.57	2802	0.034	31.02	3005	0.036	35.67
FP-85BWA2/A-K	45(113°F)	2736	0.033	20.22	3070	0.037	25.46	3394	0.041	31.12
	50(113°F)	3019	0.036	24.61	3353	0.04	30.36	3677	0.044	36.52
	60(113°F)	3584	0.043	34.69	3918	0.047	41.46	4242	0.051	48.61
	70(113°F)	4148	0.05	46.49	4483	0.054	54.28	4808	0.058	62.42

Note: In this table, The temperature of the out canal is lower 20°C(68°F) than the canal which water in.





## Cassette type

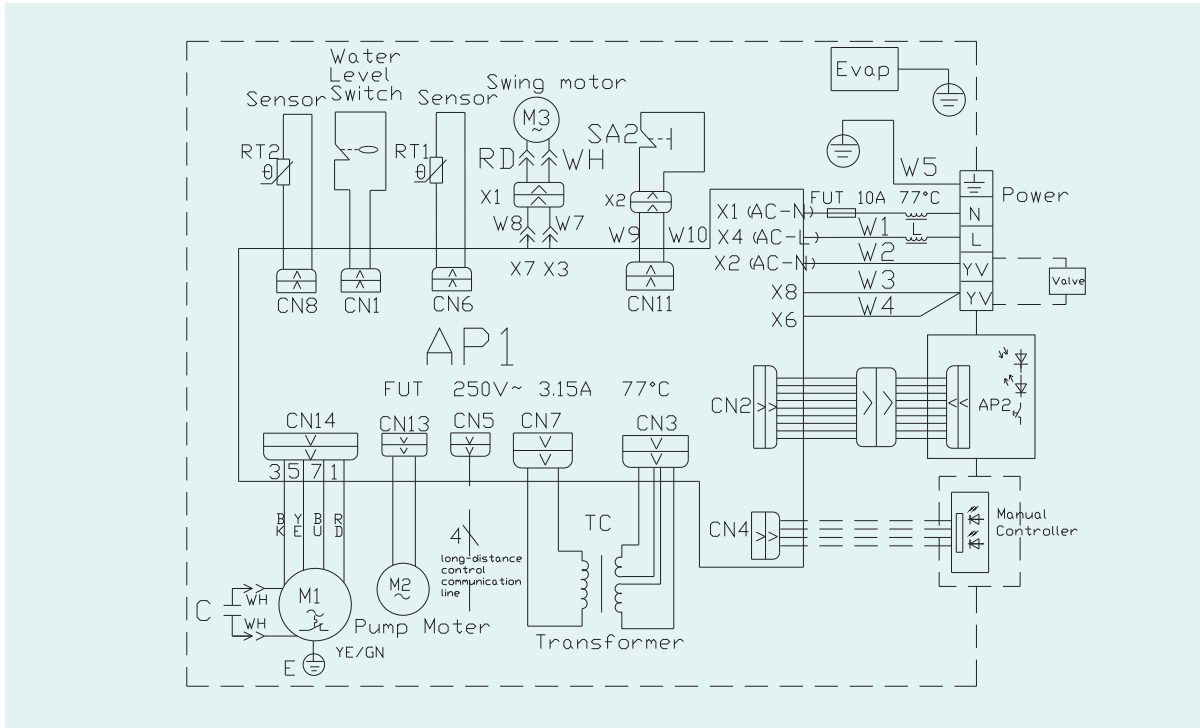

## Wall mounted:

FP-34BA2/A-K, FP-51BA2/A-K, FP-68BA2/A-K, FP-85BA2/A-K

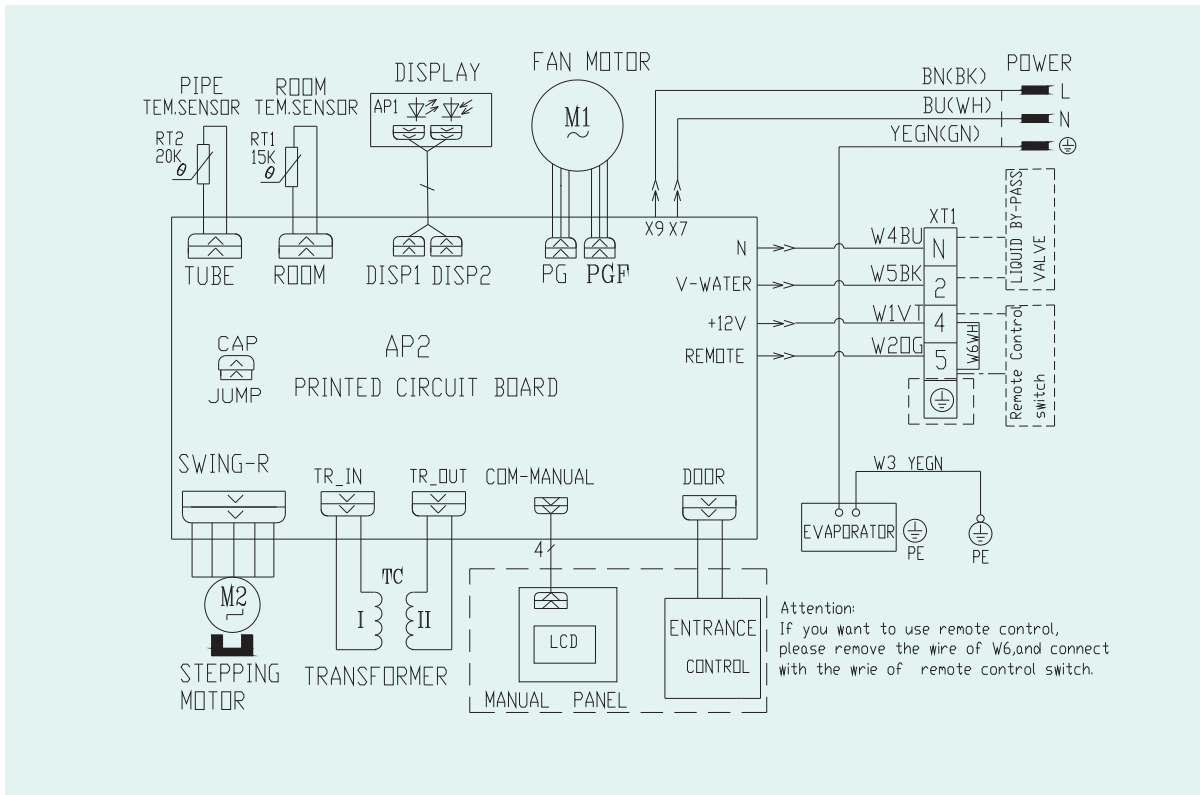

FP-51BWA2/A-K、FP-85BWA2/A-K

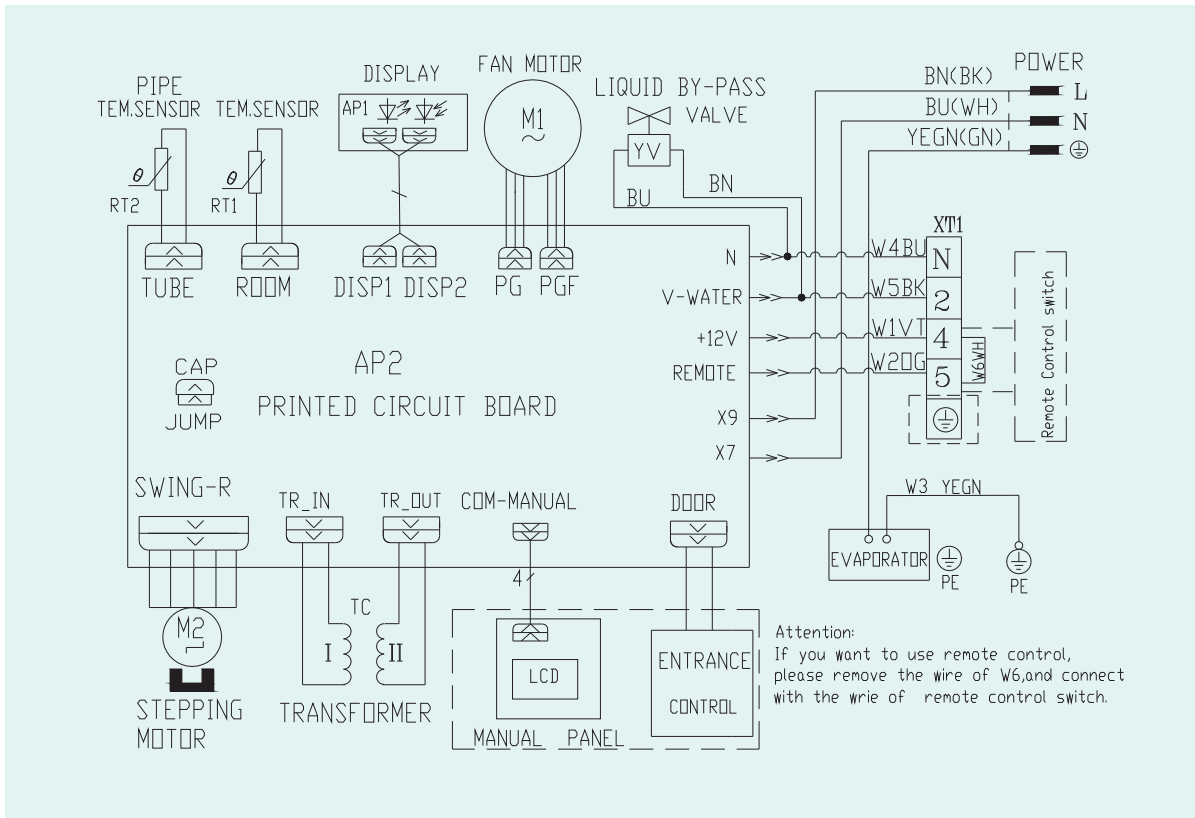



Note:

1. The power cord of unit must be copper core cable and its working temp can not exceed specified value.
2. If power cord is longer than 15m, add sectional area of it to avoid overload.

## 10 OPERATION & CONTROLS

Key-part	Specification for Wiring & Function
Three Speed Switch	<p>The unit motor is a single-phase, permanent split capacitor with the three speeds tapings HIGH/MEDIUM/LOW wired to the Terminal Block with color-coded wires.</p> <p>Terminal 1—BLACK -HIGH SPEED</p> <p>Terminal 2—YELLOW-MEDIUM SPEED</p> <p>Terminal 3—BLUE-LOW SPEED</p>
MOTOR	<p>The fan coil unit is equipped with three speed, the model of FP31~FP102 have one motor, and the model of FP136~FP204 have two motors.</p>
Motor Bearings	<p>The motors have permanently lubricated ball bearings as a standard offering.</p>
Insulation	<p>The motors are provided with class B insulation</p>

Model Name	Apperance
<p>High,mid and low joints of switch Z54352A1</p>	 <p>A rectangular white switch with two vertical sliders. The left slider is labeled 'ON' at the top and 'OFF' at the bottom. The right slider is labeled 'H' at the top, 'M' in the middle, and 'L' at the bottom. The GREE logo is at the bottom center.</p>
<p>FCU Wired remote controller WK-010PA-K</p>	 <p>A rectangular white remote controller with a blue LCD screen on the left. On the right side, there are several buttons: MODE, up arrow, down arrow, FAN, SLEEP, TIMER, and ON/OFF. The GREE logo is at the bottom center.</p>
<p>Digital fan coil thermostat WK-110PA0</p>	 <p>A rectangular white thermostat with a digital display showing '30°C'. Below the display are three buttons. On the right side, there are several buttons and a slider: a fan icon, a sun icon, a snowflake icon, and a slider with markings from 1 to 5. The GREE logo is at the bottom center.</p>
<p>Digital fan coil thermostat YB1FA</p>	 <p>A rectangular white thermostat with a large digital display showing '88°C'. Below the display are several buttons: ON/OFF, MODE, -, +, FAN, FAN, CLOCK, TIMER ON, BLOW, TEMP, TURBO, SLEEP, and LIGHT. The GREE logo is at the bottom center.</p>

# GREE

making better air conditioners



Gree Electric Appliances, Inc. of Zhuhai (“Gree”) is the largest specialized air conditioner enterprise in the world.

Gree has now become a renowned multinational enterprise that possessing 4 production bases located in Zhuhai, Chongqing, Brazil and Hefei, and five subsidiary companies, totally 37,800 employees. Annual production capacity of us is over 25 million sets of home air conditioners and annual output value of 716 million USD from commercial air conditioners.

We are always paying much attention on technical innovation. Till now, we had registered nearly 1500 patents at home or abroad. The high-end technologies we have successfully developed include the GMV multi VRF system, centrifugal chiller and, in particular, central air conditioners using ultra-low temperature heat pump, which is the first of its kind in the world and an internationally-advanced technology that has filled in a gap of China and broken the technical monopoly of the refrigeration magnates in the United States and Japan, winning widespread reputation and influence in the world refrigeration industry.

With the installation of Gree commercial air conditioners in important projects at home and abroad like Media Village for 2008 Beijing Olympic Game, Stadiums for 2010 World Cup in South Africa, as well as Indian Telecom base station, Gree commercial air conditioners are ready to develop steadily to every corner in the world, to present a more comfortable and harmony working environment and family atmosphere.



## **GREE ELECTRIC APPLIANCES ,INC.OF ZHUHAI**

Add:West Jinji R.d.,Qianshan,Zhuhai,Guangdong,China 519070

Tel:(+86-756)8614883 Fax:(+86-756)8614998

Http://www.gree.com.cn Email:gree@gree.com.cn

For continuous improvement in the products, Gree reserves the right to modify the product specification and appearance in this manual without notice and without incurring any obligations.

**SN00300261**