



Technical Sales Guide

ENERGY RECOVERY VENTILATION SYSTEM

(GC201905-I)

TECHNICAL SALES GUIDE: 50/60Hz

AIR VOLUME RANGE: 150/250/350/500m³/h

OUTDOOR TEMPERATURE: >-25°C

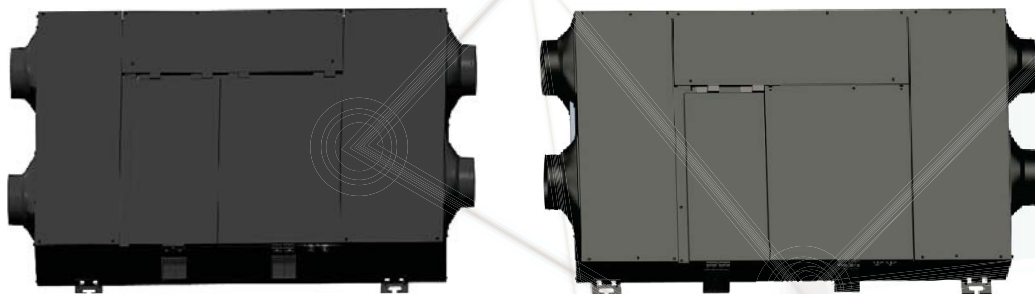

CONTENTS

- 1.PRODUCT INTRODUCTION..... 1
- 2.PRODUCT PERFORMANCE PARAMETER..... 4
- 3.PRODUCT SIZE..... 5
- 4.COMMUNICATION 8
- 5.ELECTRICAL WIRING 9
- 6.RANGE OF MATERIAL SUPPLY 12

1 PRODUCT INTRODUCTION

➔ 1.1 Product briefing

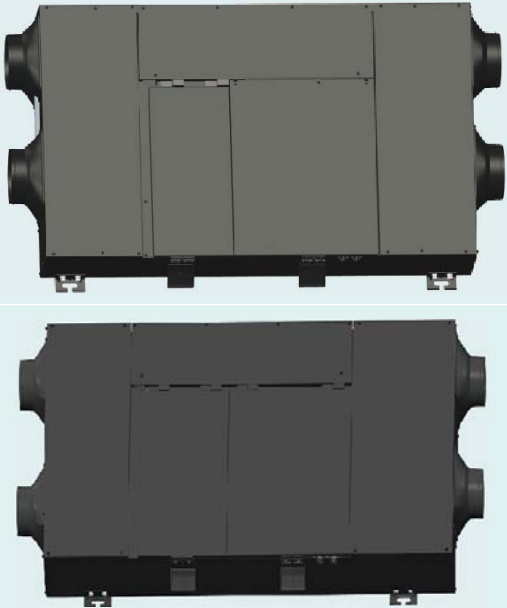
Unit model	Fresh air volume	Outline drawing
	m ³ /h	
FHBQGL-D1.5DA-T	150	
FHBQGL-D2.5DA-T	250	
FHBQGL-D3.5DA-T	350	
FHBQGL-D5DA-T	500	

➔ 1.2 Product function characteristic

Energy recovery ventilation system is an air treatment equipment that filters outdoor fresh air, conducts heat and humidity exchange with indoor discharge air and conveys fresh air inside the room after recycling discharge air heat. Energy recovery ventilation system is comprised by filter section, energy recovery core section and fan section. Filter section is consisting of F7 level filters. Energy recovery core section realizes heat and humidity exchange between fresh air and discharge air. At the same time, the unit operation mode will be adjusted according to different seasons, thus achieving energy conservation effect while assuring fresh air volume.

Compared with another Energy recovery ventilation system of ZQ series, it has the following characteristics:

	Energy recovery ventilation system of ZQ series	Energy recovery ventilation system
Ais volume	Decay as the increase of resistance	Constant air volume control, no decay of air volume
Filter	No filtration	F7 level filter, filter cleaning and replacement automatically alarm
Noise	Noise of alternating motor is big	Under low static pressure, noise of direct current motor is smaller
Power	Efficiency of alternating motor is low and power is high.	Efficiency of direct current motor is high and power is low
Structure (take the unit whose volume is 500 m ³ /h as an example)	thickness is 306mm	thickness is 240mm

1.2.1 Powerful dynamic

External static pressure of this unit is high, anti-static pressure ability of fan is strong, which will meet the requirement of transporting fresh air in long-distance.

Table 1: Volume-static pressure parameter

Model	Rated volume (m ³ /h)	Outer static pressure (Pa)
FHBQGL-D1.5DA-T	150	100
FHBQGL-D2.5DA-T	250	100
FHBQGL-D3.5DA-T	350	100
FHBQGL-D5DA-T	500	100

1.2.2 Strong control function

(1) There are 5 fan speeds for Energy recovery ventilation system, which meets fresh air model selection requirement of different indoor area and different connection pipe size.

(2) Energy recovery ventilation system has operation control function, linkage control function and auto control function.

Operation mode: this unit will choose total heat operation mode, bypass operation mode and exhaust air operation mode automatically according to outdoor air temperature, of extract air temperature and outdoor air humidity tested.

Linkage control mode: Energy recovery ventilation system is connected to multi VRF system to realize linkage control with multi VRF; If not connecting to multi VRF system, choose operation control mode to manually control the unit.

Auto operation mode: Energy recovery ventilation system is equipped with air box to detect indoor pollution degree; it will control the fan speed to operate the unit automatically.

(3) Energy recovery ventilation system has the function of filter cleaning and replacement alarming automatically.

(4) If Energy recovery ventilation system is connected to multi VRF, then IDU linkage control and one wired controller-to-multi units are available.

1.2.3 IDU appearance and particular advantage of internal design

(1) Fashionable-----sand streak black, elegant and fashionable.

(2) Maintenance is convenient-----examine, replace and clean filter, both panels adopt hinge and clasp for connection.

(3) Reliable operation-----internal insulation material is the polymer rubber of 10-20mm, which will prevent the unit from condensing within -10°C for a long period.



1.3 Product naming rule

1.3.1 Basic structure of model

FH	B	Q	G	L	-	D	□	□	□	-	T
1	2	3	4	5		6	7	8	9		10

1.3.2 Meaning of model

Table 2: Specification on model rule

No.	Name	Explanation
1	Unit code	FH—Energy recovery ventilation
2	Heat transfer method to exchange core	B—plate-fin L—rotary type
3	Energy recycle method	Q—Total heat X—Sensible heat

ENERGY RECOVERY VENTILATION SYSTEM TECHNICAL SALES GUIDE

No.	Name	Explanation
4	Purification method	G—Filter J—Static electricity filter Missing-No filtration
5	Control method	L—Linkage control
6	Installation type	D—Ceiling installation B—Wall mounted installation L—Floor standing installation
7	Volume	Nominal volume m ³ /h, representing method: volume m ³ /h/100, for example: 1.5 means the volume of 150m ³ /h.
8	Direct current	D- Direct current motor Missing-alternating current motor
9	Design No.	Put in order in the sequence of A, B, C...
10	Power specification	T—208-230V ~ ,60Hz ; 220-240V ~ , 50Hz

➔ 1.4 Controller introduction

Table 3: Controller parameter

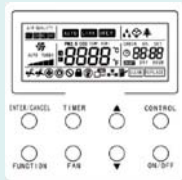
Name	Model	Picture	Outline size(mm) (W×D×H)	Installation size(mm) (W×D×H)	Function specification
Wired controller	XK112		86×86×30	86×86×25	<ol style="list-style-type: none"> 1. Control mode: auto, linkage and operation; 2. Operation mode: total heat exchange, bypass, exhaust air; 3. Timer; 4. Fan speed adjustment function: High, medium-high, medium, medium-low, low; 5. Function: child lock, filter dirty alarm, filter replacement alarm and long-distance shielded; 6. Temperature display function; 7. Air quality display function.

➔ 1.5 Product operation range

Table 4: Operation condition

Project	Outdoor temperature
Operation condition range	>25°C

2 PRODUCT PERFORMANCE PARAMETER

2.1 Unit performance parameter

Unit model		FHBQGL-D1.5DA-T	FHBQGL-D2.5DA-T	FHBQGL-D3.5DA-T	FHBQGL-D5DA-T
Rated voltage	V	220-240V/208-230V			
Rated frequency	Hz	50/60	50/60	50/60	50/60
Rated input range	W	50	100	150	300
Rated input current	A	0.35	0.7	1.0	1.9
Air Flow Volume	m ³ /h	150	250	350	500
Temperature exchange efficiency condition	/	85%	80%	75%	80%
Outer static pressure	Pa	100	100	100	100
Sound power level(H)	dB(A)	39	44	49	55
Net weight	kg	50	50	60	71.5
Appearance (W×D×H)	mm	1160*700*220	1160*700*220	1200*785*240	1385*785*240
Air inlet size (diameter)	mm	Φ149.9±0.3	Φ149.9±0.3	Φ149.9±0.3	Φ185±0.3
Air outlet size (diameter)	mm	Φ149.9±0.3	Φ149.9±0.3	Φ149.9±0.3	Φ185±0.3
Stack layer(s)		7	7	7	7

Notes:

- ① Sound power level noise is tested in semi-anechoic room according to related test method specified in standard EN ISO 3744. Actual noise may be various due to actual environment influence.
- ② Thermal efficiency is tested according to related test method and temperature condition specified in standard EN 13141-7-2010. Actual thermal efficiency may be various due to actual temperature condition.
- ③ Specifications may be changed due to product improvement. Please refer to nameplates of the units.

2.2 Filter and exchange core parameter model selection

Table 6: Filter parameter

Unit: mm

Model	filter	Energe recovery core
FHBQGL-D1.5DA-T	255×103×28.3	255×204×360
FHBQGL-D2.5DA-T	255×103×28.3	255×204×360
FHBQGL-D3.5DA-T	295×103×28.3	295×204×360
FHBQGL-D5DA-T	295×135×28.3	295×200×400
Recommended reolacing time	Cleaning and replacing reminder by wired controller	2 years

3 PRODUCT SIZE

➔ 3.1 IDU

3.1.1 Outer size of IDU

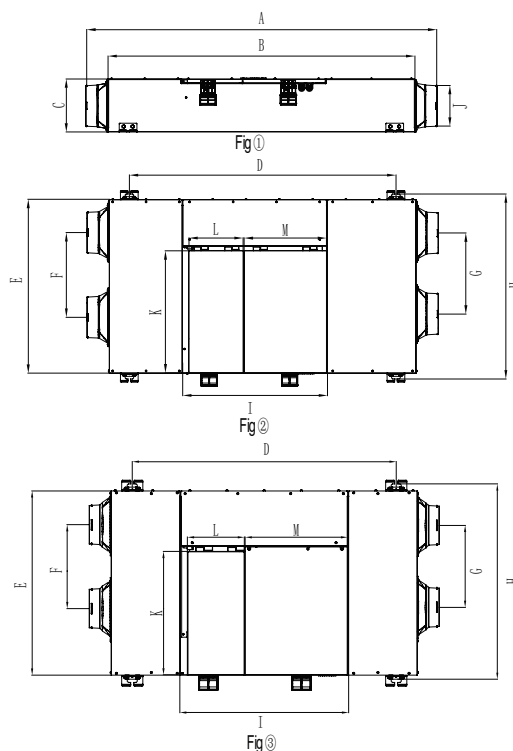

Fig ② is the access panel front view of FHBQGL-D3.5DA-T and FHBQGL-D5DA-T,
 Fig ③ is the access panel front view of FHBQGL-D1.5DA-T and FHBQGL-D2.5DA-T
 Fig 1 Size label

Table 7: Size parameter

Unit: mm

Model	A	B	C	D	E	F	G	H	I	J	K	L	M
FHBQGL-D1.5A-T	1326	1160	220	1000	700	318	311	740	636	150	470	216	388
FHBQGL-D2.5A-T	1326	1160	220	1000	700	318	311	740	636	150	470	216	388
FHBQGL-D3.5A-T	1366	1200	240	897	785	424	377	825	650	150	555	277	343
FHBQGL-D5A-T	1584	1385	240	1203	785	383	366	825	653	185	555	248	375

3.1.2 IDU installation requirement

The user shall entrust professional heating and ventilation engineers to conduct equipment model selection and engineering design, and hire experienced construction department to complete the construction. Design and construction shall be carried out according to relevant national standards and rules. For any engineering accidents due to incorrect installation, the user shall undertake all responsibilities. If the equipment cannot operate normally due to improper installation according to the stipulations, for any subsequent after-sales maintenance and services, we are entitled to charge corresponding expenses.

The user shall self-prepare PVC ventilating pipe to convey fresh air and exhaust air. When airflow is passing the pipe, certain resistance might occur, the resistance will influence filter replacement period. Generally speaking, the higher the pipe resistance is, the shorter the filter replacement period is. During practical engineering installation, if the pipe length is too long, pipe diameter is too small, too many elbow etc., wind resistance of the pipe will increase, therefore, try to decrease the max. pipe resistance as much as possible to avoid decline of overall performance due to irrational pipe installation. Please conduct installation design according to the following principles recommended:

- (1) Total length of fresh air duct shall be designed according to air outlet static pressure; material of air duct shall be fire resistant or non-inflammable.
- (2) No more elbows in pipe. The bending part of elbow shall be arc, avoid any elbows on the right angle of 90°.
- (3) Pipe wall shall be smooth, no dust nor folding. For any indoor or outdoor air outlet accessories, please purchase them in Gree fresh air sales point.
- (4) If the user wants to lower indoor noise, try to connect air duct silencer in series. There are many silencers, please ask professional staff for guidance. After installing proper silencers, noise in air outlet shall decrease 4-6dB(A).
- (5) Replace internal air filter at regular intervals. During design and installation process, leave maintenance space at the lower part of the unit. Suggested reserved size for access hole is 600(L) X600(W) (mm).

Notes:

When installing FHBQGL-D1.5DA-T and FHBQGL-D2.5DA-T, access panel 1 and 2 shall completely expose to access hole, so that the user can dismantle access panel 2 with screwdriver.

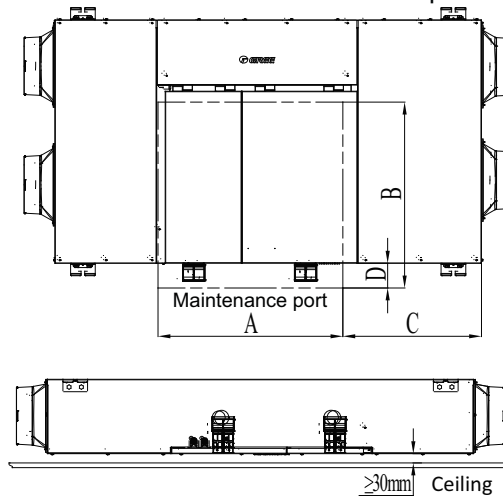

Fig 2 Access hole diagram

Table 8: Unit maintenance space parameter

Model	Unit: mm			
	A	B	C	D
FHBQGL-D1.5A-T	600	600	260	80
FHBQGL-D2.5A-T	600	600	260	80
FHBQGL-D3.5A-T	600	600	315	80
FHBQGL-D5A-T	600	600	450	80

- (1) Installation method for the unit is ceiling type, requirement for installation height: distance between the unit and the floor shall be over 2.3m.
- (2) Energy recovery ventilation system adopts M10 expansion bolt and ceiling for fixing.

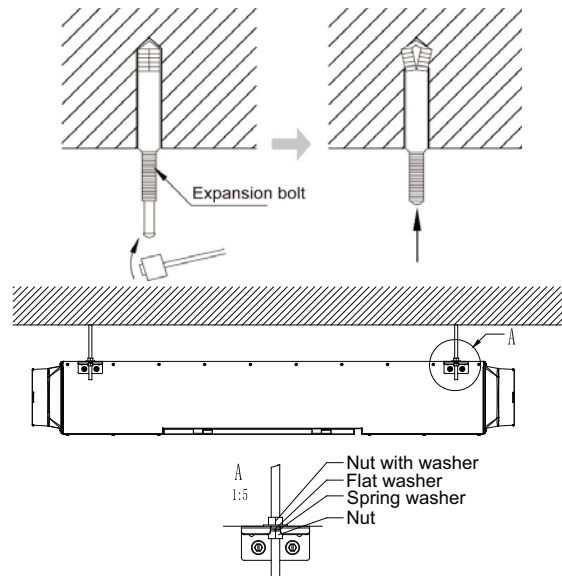

Fig 3 Lifting diagram

(3) If necessary, the user shall prepare hose which shall be used to connect air inlet/outlet of main unit and PVC pipe by themselves for engineering installation, when installing the hose, the transition shall be smooth, no folding nor bending.

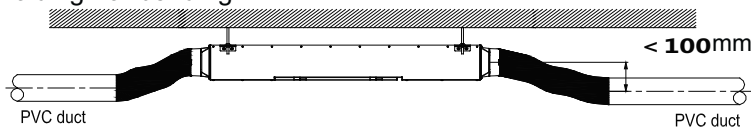

Fig 4 Connection diagram for hose

(4) Energy recovery ventilation system shall not be installed in the following locations:

- 1) Fire disaster or overhear might occur if installing in high temperature location or places with open fire.
- 2) In any places with oil mist/gas, e.g. kitchen, fire disaster might occur. If you want to install it in kitchen, please install ceiling to separate supply air fan and oil mist/gas.
- 3) If the installation location is wet, e.g. bathroom, there might be electricity leakage or other problems. If you want to install it in bathroom, please install ceiling to separate supply air fan and humidity.
- 4) If any machines with radioactive electromagnetic wave are near the installation location, the equipment might be out of work.

3.1.3 IDU installation space requirement

Unit installation space diagram:

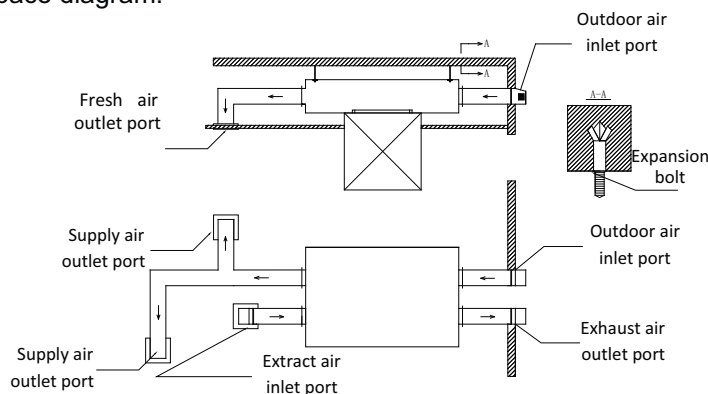

Fig 5 Installation diagram

During ceiling installation of Energy recovery ventilation system, the bottom of the unit shall reserve access hole for the convenience of replacing filter or motor maintenance.

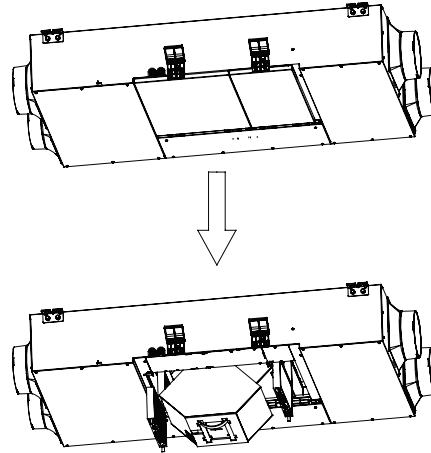

Fig 6 Replacement diagram of filter component and Energy recovery ventilation core

4 COMMUNICATION

4.1 Connection method of communication cord terminal

If Energy recovery ventilation system is connected to multi VRF system, then it need to have communication connection with multi VRF ODU, port location: D1 and D2. Connection method is to fixed with screws.

Connection between wired controller and IDU electrical box shall be fixed with screws, connection port location: H1 and H2.

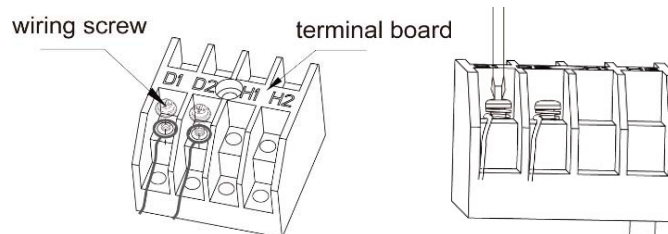
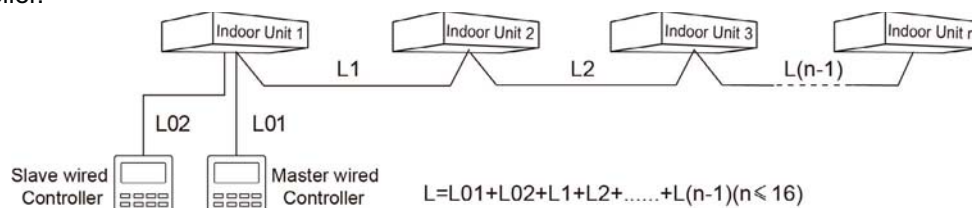

Fig 7 Communication terminal

4.2 Communication cord wiring

If the unit is installed in places with strong electromagnetic interference, shielded wire must be used as communication cord between Energy recovery ventilation system and wired controller, while shielded twisted cable must be used as communication cord between Energy recovery ventilation system and multi VRF ODU.

(1) Model selection for communication cord between Energy recovery ventilation system and wired controller.



ENERGY RECOVERY VENTILATION SYSTEM TECHNICAL SALES GUIDE

Type of wire	Total length of communication wire between unit and wired controller L (m)	Wire diameter (mm ²)	Material standard	Remarks
Light/Ordinary PVC sheathed twisted-pair copper core wire (RVVS)	L01 or L02≤10	2×0.75 ~ 2×1.5	IEC 60227-5	1.Total length of communication wire cannot exceed 250m 2.If unit is installed in a place with intense magnetic field or strong interference, it's necessary to use shielded wire (RVVSP)
	L≤250			
Shielded light/ordinary PVC sheathed twisted-pair copper core wire (RVVSP)	L≤250	2×0.75 ~ 2×1.5	IEC 60227-5	

(2) Model selection of communication cord between Energy recovery ventilation system and multi VRF ODU

Type of wire	Total length of communication wire between unit and VRF ODU L (m)	Wire diameter (mm ²)	Material standard	Remarks
Light/Ordinary PVC sheathed twisted-pair copper core wire (RVVS)	L≤1000	≥2×0.75	IEC 60227-5	The communication wire can be prolonged if the wire diameter is 2×1mm ² . But the total length of communication wire can't exceed 1500m
Shielded light/ordinary PVC sheathed twisted-pair copper core wire (RVVSP)	L≤1000	≥2×0.75	IEC 60227-5	If unit is installed in a place with intense magnetic field or strong interference, it's necessary to use shielded wire (RVVSP)

5 ELECTRICAL WIRING

➔ 5.1 Air switch and model selection for diameter

Table 9: Air switch and model selection for diameter

Model	Power	Air switch capacity (A)	Minimum sectional area for ground wire (mm ²)	Minimum sectional area for power cord (mm ²)
FHBQGL-D1.5DA-T	208-230V ~ , 60Hz	6	1.0	1.0
FHBQGL-D2.5DA-T		6	1.0	1.0
FHBQGL-D3.5DA-T	220-240V ~ , 50Hz	6	1.0	1.0
FHBQGL-D5DA-T		6	1.0	1.0

Notes:

- ① The above circuit breaker and specification of power cord is decided based on the max. power (max. current), circuit breaker shall adopt all-pole disconnected type.
- ② The above power cord specification is concluded based on multi core copper cable (e.g, YJV copper core polyethylene insulated PVC cable) exposing in wire casing with usage environment of 40°C and working temperature for cable of 90°C. If usage condition is different, please calculate and adjust according to national standard.
- ③ Specification of the above circuit breaker is concluded based on the condition that, when circuit breaker is working, temperature of its surrounding environment is 40°C.If usage condition is different, please calculate and adjust according to specification of circuit breaker.

- ④ Install cut-off device near the unit. The minimum distance between each stage of cut-off device should be 3mm.

➔ 5.2 External wiring interface

Table 10: Wiring interface statement

External wiring interface	Power supply	Quantity	3	
		Label	L、N、PE	
	IDU/ODU communication	Quantity	2	
		Label	D1、D2	
	Communication between wired controller and IDU		Quantity	2
			Label	H1、H2

➔ 5.3 Internal wiring

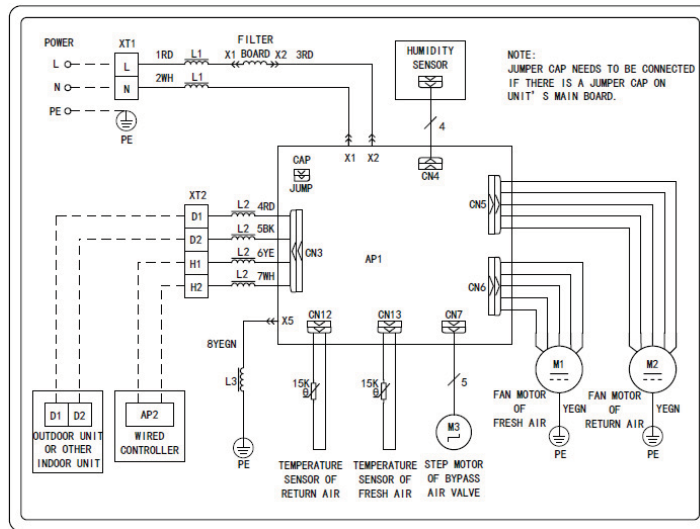

Internal wiring diagram of FHBQGL-D1.5DA-T and FHBQGL-D2.5DA-T

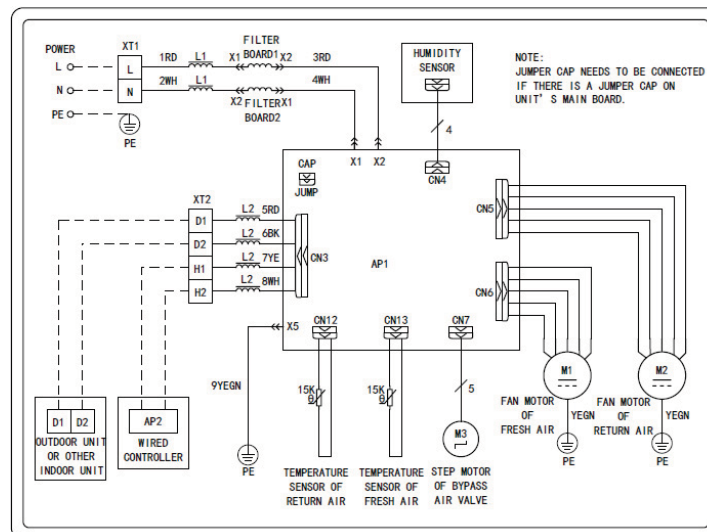

Internal wiring diagram of FHBQGL-D3.5DA-T

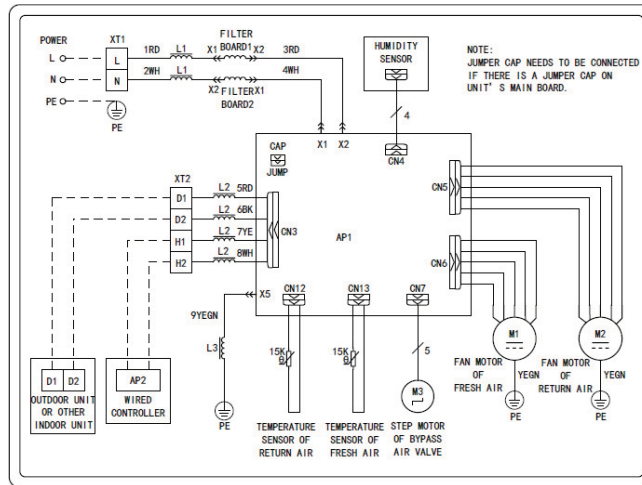

Internal wiring diagram of FHBQGL-D5DA-T
Fig 8 Internal wiring diagram

Note:

On-site wiring shall subject to the wiring diagram pasted on the unit.

5.4 External wiring

Wiring diagram of FHBQGL-D1.5DA-T, FHBQGL-D2.5DA-T, FHBQGL-D3.5DA-T and FHBQGL-D5DA-T.

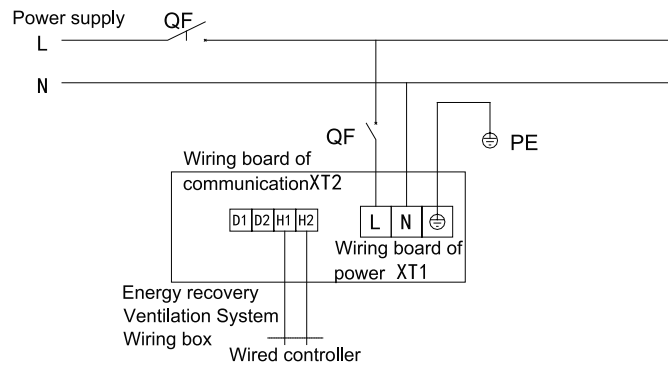

Fig 9 External wiring diagram

5.5 Electrical installation requirement

- (1) Conduct installation according to national wiring standard.
- (2) Fix the power reliably to avoid wiring terminal carrying load. Please don't pull power cord with force.
- (3) Power cord diameter shall be enough big, adopt cable connection. If power cord and connection cable are damaged, special cable must be used for replacement.
- (4) Wiring of wired controller shall be installed in wire casing or secretly.
- (5) All electrical installation must be conducted by professional staff based on local laws, stipulations and this manual.
- (6) Earthing shall be conducted in special earthing devices of architecture firmly and installed by professional staff.
- (7) Air switch and electricity leakage switch which can cut off power of the whole system must be installed.
- (8) All-pole cutoff device with the distance to the contact no less than 3mm shall be installed in power supply circuit.
- (9) Air switch shall have magnetic release and thermal release function to guarantee short circuit and overload is protected.
- (10) On-site wiring shall subject to the wiring diagram pasted on the unit.

6 RANGE OF MATERIAL SUPPLY

S= Standard component.
 O= Component self-prepared by the user.
 P= Component purchased by the user.

Tabel 11: Material supply list

Material supply content	Quantity(pc)	Specification	Category	Remark
IDU	1	-	S	
Wired controller	1	XK112	S	
Padded nut	4	M10	S	
Nut	4	M10	S	
Flat washer	4	10	S	
Spring washer	4	10	S	
Signal cord among units	1	10m	O	
Power cord		-	O	
Outdoor air inlet/outlet	-	FK-XW150A FK-XW150B	P	
Indoor air inlet/outlet	-	FK-X075A FK-X100A	P	
Air duct and air duct connection component	-	-	O	
Air duct thermal material	-	-	O	

Note:

If you need the above component, please contact local sales company.

Note:

Due to product upgrade, component model might be different, please contact local sales company or Gree headquarter.



GREE ELECTRIC APPLIANCES, INC. OF ZHUHAI 519070

Add: West Jinji Rd, Qianshan Zhuhai, Guangdong, China

Tel: (+86-756)8522218

Fax: (+86-756)8669426

E-mail: gree@gree.com.cn www.gree.com

SJ00522449