



Service Manual

Duct Type Split Air Conditioner Inverter Series

(GC201812-IV)

Capacity: 20kW~40kW

Rate Frequency: 50/60Hz

Operation Range: -7°C~48°C











Contents

| | |
|---|------------|
| PRODUCT | 1 |
| 1 Product List | 2 |
| 2 Nomenclature | 2 |
| 3 Specifications | 3 |
| CONTROL | 6 |
| 1 Wired Controller | 7 |
| 2 Remote Controller YAP1F | 12 |
| 3 Monitoring Software | 13 |
| INSTALLATION | 56 |
| 1 Engineering Installation Preparation and Notice | 57 |
| 2 Installation Materials Selection | 57 |
| 3 Installation of Indoor Unit | 60 |
| 4 Installation of Outdoor Unit | 63 |
| 5 Pipeline design of Refrigerant | 66 |
| 6 Installation of Drain pipe | 67 |
| 7 Electrical Installation | 70 |
| DEBUGGING & MAINTENANCE | 71 |
| 1 Debugging | 72 |
| 2 Troubleshooting | 83 |
| 3 Wiring Diagram | 117 |
| 4 Disassembly And Assembly Procedure Of Main Parts | 120 |
| 5 Exploded Views And Part List | 122 |

PRODUCT

1 Product List

| Model (Product List) | Cooling Capacity | Heating Capacity | Power Supply | Refrigerant | Appearance | |
|----------------------------------|------------------|------------------|-----------------------------------|-------------|---|---|
| | kW | kW | | | Outdoor | Indoor |
| FGR20Pd/DNa-X (CF01000730) | 20 | 22 | 3N/380- 415V/50Hz / 60Hz | R410a |  |  |
| FGR25Pd/DNa-X (CF01000740) | 25 | 27.5 | | |  |  |
| FGR30Pd/DNa-X (CF01000750) | 30 | 33 | | |  |  |
| FGR40Pd/D(2)Na-X (CF01000760) | 40 | 43 | | |  |  |

2 Nomenclature

| | | | | | | | |
|-----------|----------|-----------|-----------|-------------|-----------|-----------|------------|
| <u>FG</u> | <u>R</u> | <u>40</u> | <u>Pd</u> | <u>D(2)</u> | <u>Na</u> | <u>-X</u> | <u>(I)</u> |
| 1 | 2 | 3 | 4 | 5 | 6 | 7 | 8 9 |

| NO. | Description | Options |
|-----|------------------------------|---|
| 1 | Ducted Type Air Conditioner | - |
| 2 | Unit type | Cooling only type-omitted |
| | | Heat pump |
| | | Auxiliary hot water plate and pipe type-W |
| 3 | Cooling capacity | Nominal cooling capacity (kW) |
| 4 | Frequency conversion system | Fixed frequency-omitted |
| | | Frequency conversion-Pd |
| 5 | Design No. | Arranged based on A, B, C, D, and so on |
| 6 | The number of outdoor units | One outdoor unit-omitted |
| | | Two outdoor units-(2) |
| 7 | Refrigerant | R22-omitted |
| | | R407-N |
| | | R410a-Na |
| | | Others to be applied for when they are used |
| 8 | Power type | 380-415V 3Ph~,50/60Hz-X |
| | | (The unit to be exported must be expressed) |
| 9 | Indoor and outdoor unit code | Outdoor unit-(O) |
| | | Indoor unit-(I) |
| | | The entire unit is not expressed. |

3 Specifications

| Model | Heat pump | | FGR20Pd/DNa-X | FGR25Pd/DNa-X | |
|---------------------------|-------------------------|---------|--------------------|--------------------|---------------|
| Capacity | Cooling | kW | 20 | 25 | |
| | Heating | kW | 22 | 27.5 | |
| SEER/SCOP | | W/W | 4.90/3.41 | 4.61/3.61 | |
| Power supply | | Ph/V/Hz | 3N/380-415/(50/60) | 3N/380-415/(50/60) | |
| Power input | Cooling | kW | 7.8 | 9.4 | |
| | Heating | kW | 6.8 | 8.9 | |
| Current input | Cooling | A | 16.5 | 18.9 | |
| | Heating | A | 14.4 | 17.2 | |
| Refrigerant charge volume | | kg | 6.4 | 8.0 | |
| Indoor unit | Airflow volume | | CFM | 2178 | 2472 |
| | | | m ³ /h | 3700 | 4200 |
| | ESP | Rated | Pa | 120 | 120 |
| | | Range | Pa | 0-250 | 0-250 |
| | Sound pressure level | | dB(A) | 52 | 53 |
| | Dimension (W×D×H) | Outline | mm | 1315×760×385 | 1520×840×450 |
| | | Package | mm | 1578×883×472 | 1788×988×580 |
| Net Weight/Gross weight | | kg | 82/104 | 99/134 | |
| Outdoor unit | Sound pressure level | | dB(A) | 62 | 63 |
| | Dimension (W×D×H) | Outline | mm | 940×320×1430 | 940×460×1615 |
| | | Package | mm | 1033×433×1580 | 1033×573×1765 |
| | Net Weight/Gross weight | | kg | 120/130 | 146/162 |
| Connection pipe | Outer diameter | Liquid | Inch(mm) | Φ3/8 | Φ3/8 |
| | | Gas | Inch(mm) | Φ3/4 | Φ7/8 |
| | Max. distance | Height | mm | 30 | 30 |
| | | Length | mm | 70 | 70 |
| Loading quantity | 20'GP/40'GP/40'HQ | | set | 12/24/24 | 10/20/22 |

| Model | Heat pump | | FGR30Pd/DNa-X | FGR40Pd/D(2)Na-X | |
|---------------------------|-------------------------|---------|-------------------|--------------------|--------------------|
| Capacity | Cooling | | kW | 30 | 40 |
| | Heating | | kW | 33 | 43 |
| SEER/SCOP | | | W/W | 4.70/3.40 | 4.60/3.42 |
| Power supply | | | Ph/V/Hz | 3N/380-415/(50/60) | 3N/380-415/(50/60) |
| Power input | Cooling | | kW | 11.3 | 15.4 |
| | Heating | | kW | 10.3 | 13.9 |
| Current input | Cooling | | A | 22.7 | 27.8 |
| | Heating | | A | 20.7 | 26.4 |
| Refrigerant charge volume | | | kg | 9.5 | 6.4×2 |
| Indoor unit | Airflow volume | | CFM | 3060 | 4120 |
| | | | m ³ /h | 5200 | 7000 |
| | ESP | Rated | Pa | 120 | 120 |
| | | Range | Pa | 0-250 | 0-250 |
| | Sound pressure level | | dB(A) | 55 | 56 |
| | Dimension (W×D×H) | Outline | mm | 1520×840×450 | 1680×900×650 |
| | | Package | mm | 1788×988×580 | 1893×1123×850 |
| | Net Weight/Gross weight | | kg | 105/145 | 165/210 |
| Outdoor unit | Sound pressure level | | dB(A) | 65 | 66 |
| | Dimension (W×D×H) | Outline | mm | 940×460×1615 | 940×320×1430 |
| | | Package | mm | 1033×573×1765 | 1033×433×1580 |
| | Net Weight/Gross weight | | kg | 175/190 | (120/130) X2 |
| Connection pipe | Outer diameter | Liquid | Inch(mm) | Φ1/2 | Φ3/8 |
| | | Gas | Inch(mm) | Φ1 | Φ3/4 |
| | Max. distance | Height | mm | 30 | 30 |
| | | Length | mm | 70 | 70 |
| Loading quantity | 20'GP/40'GP/40'HQ | | set | 10/20/22 | 7/18/18 |

Note:

- ① Specifications may be changed due to product improvement. Please refer to nameplates of the units.
- ② Noise data are collected from a semi-anechoic room. Decibels may be slightly higher in actual operation due to environmental change.
- ③ Above parameters are tested under the condition:high fan speed.
- ④ Cooling : Indoor air temperature 27°C DB/19°C WB, Outdoor air temperature 35°C DB/24°C WB.
- ⑤ Heating : Indoor air temperature 20°C DB/15°C WB, Outdoor air temperature 7°C DB/6°C WB.

CONTROL

1 Wired Controller

1.1 Control panel



Fig.2.1 Appearance of wired controller

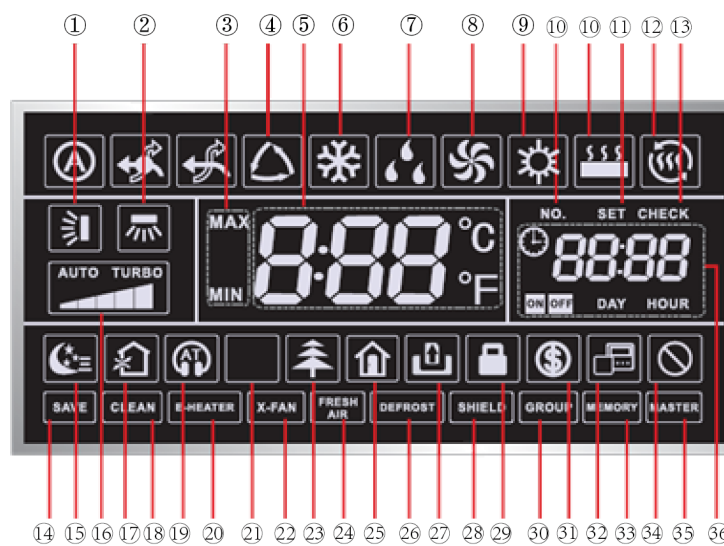
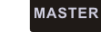



Fig.2.2 LED graphics of wired controller

Table 2.1 LED display instruction:

| No. | Symbols | Instructions |
|-----|---------|---|
| 1 | | Up and down swing function. |
| 2 | * | Left and right swing function. |
| 3 | | It's valid under Save mode and displays during setting process. Temperature lower limit for Cooling: Limit the minimum temperature value under Cooling or Dry mode. Temperature upper limit for Heating: Limit the maximum temperature value under Heating, Space Heating or 3D Heating mode. |
| 4 | * | Auto mode (Under Auto mode, the indoor units will automatically select their operating mode as per the temperature change so as to make the ambient comfortable.). |

| No. | Symbols | Instructions |
|-----|---------|---|
| 5 | | It shows the setting temperature value(In case the wired controller is controlling a Fresh Air Indoor Unit, then the temperature zone will display FAP.). |
| 6 | | Cooling mode. |
| 7 | | Dry mode. |
| 8 | | Fan mode. |
| 9 | | Heating mode. |
| 10 | | When inquiring or setting project number of indoor unit, it displays "NO." icon. |
| 11 | | Floor Heating mode (When Heating and Floor Heating simultaneously shows up, it indicates 3D Heating is activated.). |
| 12 | | Display "SET" icon under parameter setting interface. |
| 13 | | Space Heating mode. |
| 14 | | Display "CHECK" icon under parameter view interface. |
| 15 | | Outdoor unit operates under Save mode/upper limit of system capacitor less 100%/remote Save status. |
| 16 | | Sleep status. |
| 17 | | Current set fan speed (including auto, low speed, medium-low speed, medium speed, medium-high speed, high speed and turbo seven status). |
| 18 | | Air status, Indoor unit optional function. |
| 19 | | Remind to clean the filter. |
| 20 | | Quiet status (including Quiet and Auto Quiet two status). |
| 21 | | Allow auxiliary electric heating On icon. |
| 22 | | Light On/Off function. |
| 23 | | X-fan function. |
| 24 | | Health function, Indoor unit optional function. |
| 25 | | Reserved function. |
| 26 | | Out function. |
| 27 | | Outdoor unit defrosting status. |
| 28 | | Gate-control function. |
| 29 | | Shielding status. |
| 30 | | Child Lock status. |
| 31 | | One wired controller controls multiple indoor units. |
| 32 | | Save status of indoor unit. |
| 33 | | It indicates the current wired controller is the slave wired controller (address of wired controller is 02). |
| 34 | | Memory status (The indoor unit resumes the original setting state after power failure and then power recovery). |
| 35 | | Invalid operation. |

| No. | Symbols | Instructions |
|-----|---|---|
| 36 |  | Current wired controller connects master indoor unit. |
| 37 |  | Timer zone: Display system clock and timer status. |

Note: When wired controller is connected with different indoor units, some functions will be different.

Button Graphics:

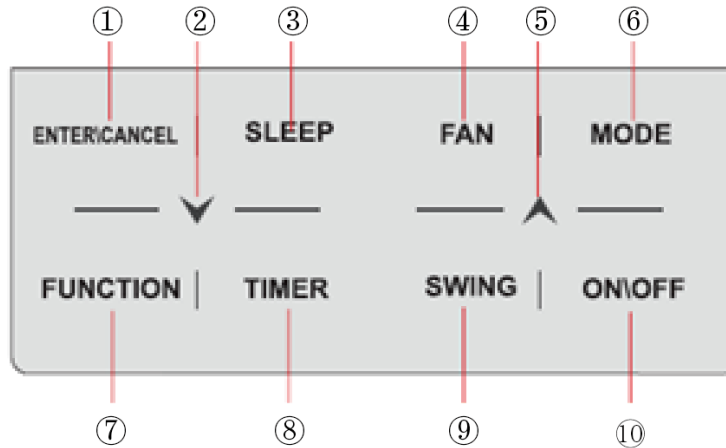

Fig.2.3 Button graphics

1.2 Installation and removal

1.2.1 Installation dimensions

Edition One:

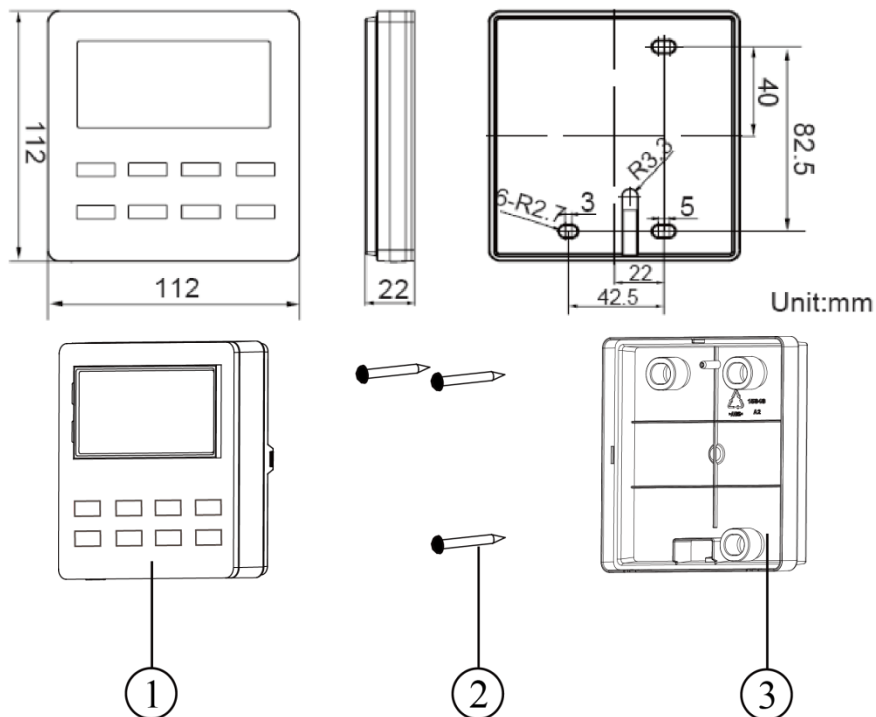

Fig. 2.4 Parts of wired controller

| No. | 1 | 2 | 3 |
|------|---------------------------|--------------------------------|-------------------------------|
| Name | Panel of wired controller | Self-tapping Screw ST3.9X25 MA | Soleplate of wired controller |
| Q'ty | 1 | 3 | 2 |

Edition Two :

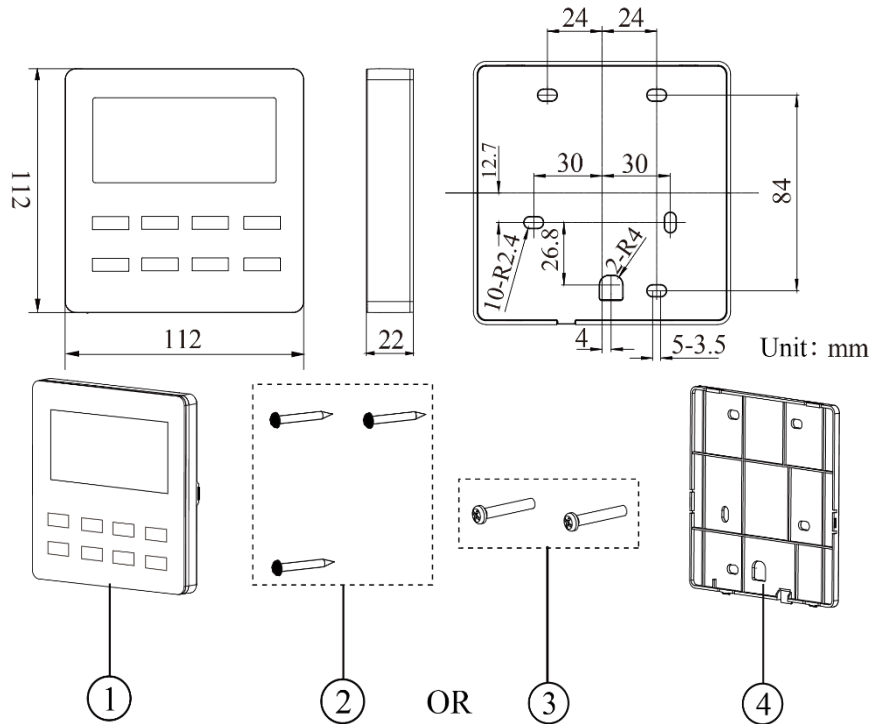

Fig. 2.5 Parts of wired controller

| No. | 1 | 2 | 3 | 4 |
|------|---------------------------|--------------------------------|-------------|-------------------------------|
| Name | Panel of wired controller | Self-tapping Screw ST3.9X25 MA | Screw M4×25 | Soleplate of wired controller |
| Q'ty | 1 | 3 | 2 | 1 |

1.2.2 Installation method

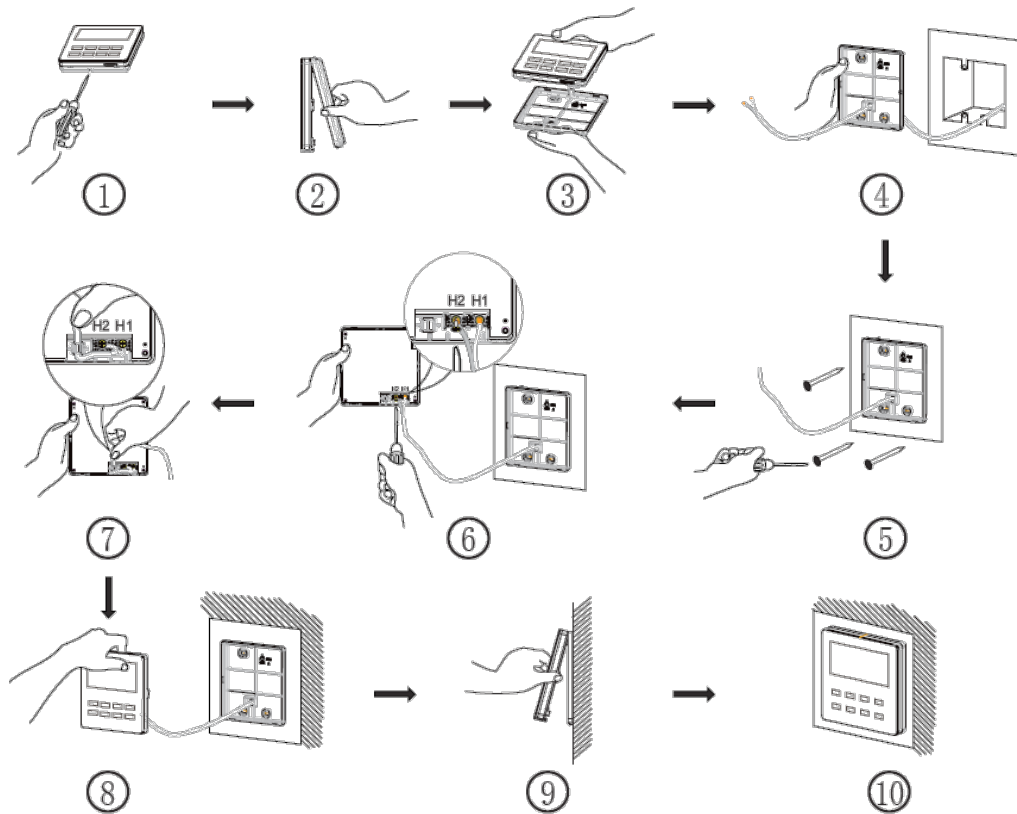



Fig.2.6 Installation of Wired Controller

Above is a simple installation method of wired controller. Please pay attention to the following:

- (1) Before installation, disconnect power of the indoor unit. Do not operate when power is connected.

- (2) Pull out the 2-core twisted pair cable from the installation hole on the wall and lead it through the hole  on the back plate of wired controller.
- (3) Place the wired controller on wall and secure its back plate on wall with screw M4X25.
- (4) Connect the 2-core twisted pair cable to terminal H1 and terminal H2. Tighten up the screws.
- (5) Stick the cable in the slot that is left of the terminals and buckle the wired controller's panel with its back plate.

Note:

If caliber of the communication cord is too large, which causes difficulty in leading or sticking the cord according to above point 2 and point 5, strip some of the sheath of the communication cable to meet the installation requirement.

1.2.3 Removal method

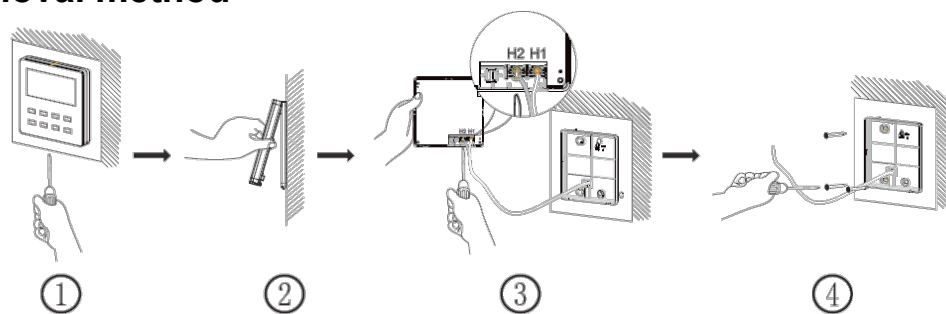

Fig.2.7 Removal of Wired Controller

1.2.4 Connection of communication cord

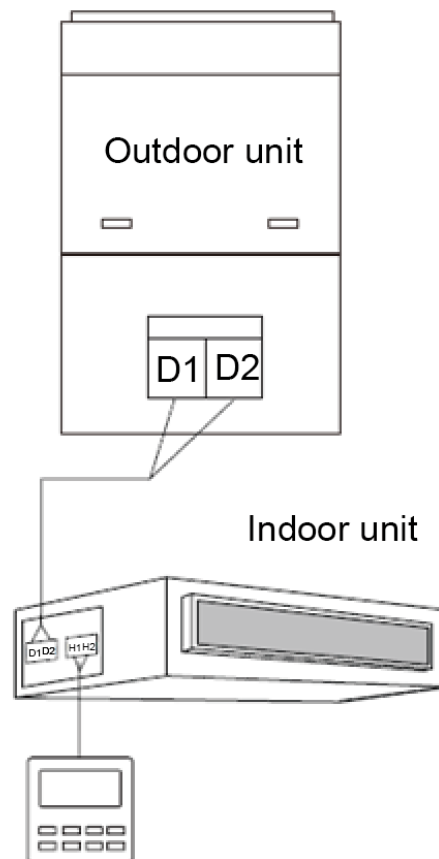
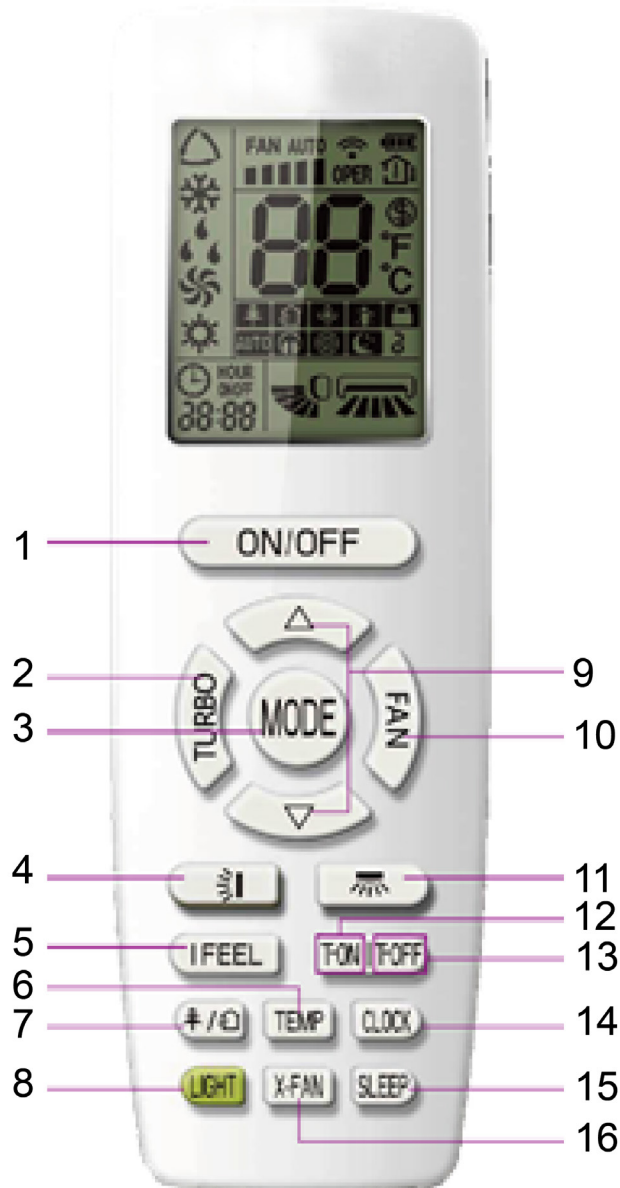





Fig.2.8 One wired controller controls one indoor unit

2 Remote Controller YAP1F



Button name and function introduction

| No. | Button name | Function |
|-----|---|--|
| 1 | ON/OFF | Turn on or turn off the unit |
| 2 | TURBO | Set turbo function |
| 3 | MODE | Set operation mode |
| 4 |  | Set up&down swing status |
| 5 | I FEEL | Set I FEEL function |
| 6 | TEMP | Switch temperature displaying type on the unit's display |
| 7 |  | Set health function and air function |
| 8 | LIGHT | Set light function |
| 9 | X-FAN | Set X-FAN function |
| 10 | SLEEP | Set sleep function |

| No. | Button name | Function |
|-----|---|-----------------------------|
| 11 | CLOCK | Set clock of the system |
| 12 | TOFF | Set timer off function |
| 13 | TON | Set timer on function |
| 14 |  | Set left&right swing status |
| 15 | FAN | Set fan speed |

3 Monitoring Software

3.1 Function introduction

Integrating with telecommunication technology and computing software, Gree Commissioning Tool Kits can realize the comprehensive monitor, control and commissioning on central air conditioners. It is an efficient solution for the management of central air conditioners that are separated in different parts of a building. Administrator doesn't need to control every unit on site, but rather controls the units by just sitting in front of a computer. This will not only improve the productivity, but also reduce cost on human resources, property and management.

Gree Commissioning Tool Kits can monitor and control the duct type split air conditioner inverter series. User can monitor and control units by monitoring the computer. This software is an efficient tool for the intelligent air conditioning management as well as installation and after-sales service and commissioning. It can debug units and control units' operation status quickly and conveniently. It will not only improve the productivity but also reduce the difficulty and cost of commissioning and maintenance, providing better and faster service to customers.

3.2 Connection of computer and units

It can be connected with single-system network or multi-system network. In the single-system network, indoor units or outdoor units are connectable, while in the multi-system network, only the master outdoor unit can be connected.

Seen from the diagram, Gree commissioning network is made up of 3 parts:

The 1st part is the monitoring computer, including Gree debugger and Gree USB converter driver that are installed in the computer.

The 2nd part is Gree USB converter, which is to convert the air conditioning communication into computing communication. This part is made up of Gree USB data converter and USB data wire.

The 3rd part is air conditioners, including outdoor units, indoor units and the connection wires. If connection wire is not long enough, it's OK to connect via the patching board of the commissioning tool kits. In a single-system network, both indoor units and outdoor units can be connected, while in a multi-system network, only the master outdoor unit can be connected.

3.3 Parts introduction

3.3.1 List of parts

| Name | Model | Material no. | Remark |
|-------------------------|-----------|--------------|--|
| Gree USB data converter | ME40-00/B | MC200062 | Convert the air conditioning communication into computing communication. |

| Name | Model | Material no. | Remark |
|---------------------------------------|--------------|--------------|--|
| Gree Commissioning Tool Kits (CD-ROM) | DE40-33/A(C) | MC200068 | Include Gree debugger, monitoring software, USB driver and USB converter configuring software. |
| USB wire | \ | 40020082 | Wire connecting computer's USB interface and converter. |
| Communication board | \ | 30118015 | This board can be used when units are far from the computer. |
| Board connection wire (1m) | \ | 4001023229 | 4-core wire connecting units and converter. |
| Board connection wire (5.5m) | \ | 4001023214 | 4-core wire connecting units and converter. |
| Instruction manual | \ | 66174100018 | Instruction manual. |

3.3.2 Gree USB data converter

3.3.2.1 Functions introduction

Gree USB data converter will convert the RS485, HBS and CAN communication within the air conditioners into the communication that is recognizable by computer's USB interface.

3.3.2.2 Appearance

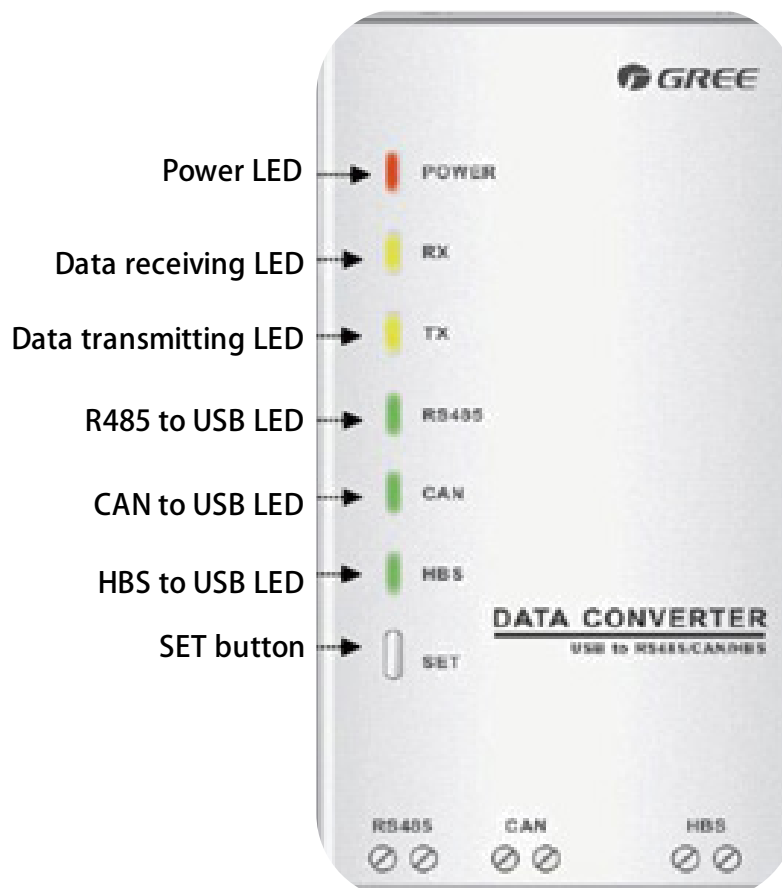

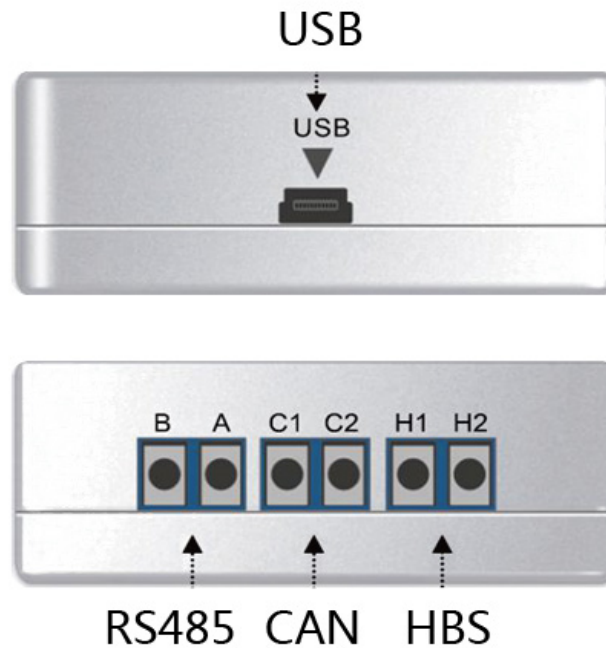

3.3.2.3 Operation instruction

- (1) Power LED:a red light. If the red light is on, it indicates normal power supply. If the red light is off, it indicates the power supply of converter is not normal.
- (2) Communication LEDs:yellow lights. When converter is working and the computer is transmitting data, the TX data transmitting light will be flickering. When units are uploading data to the computer, the RX data receiving light will be flickering.
- (3) When converter is under RS485 data transferring mode, the function LED of RS485 to USB will be on.
- (4) When converter is under CAN data transferring mode, the function LED of CAN to USB will be on.
- (5) When converter is under HBS data transferring mode, the function LED of HBS to USB will be on.
- (6) USB interface:connect USB data wire.
- (7) CAN interface:When converter is under CAN communication mode, connect air conditioner's CAN data interface. CAN interface exhibits no polarity (A and B are equal).
- (8) HBS interface:When HBS converter is under HBS communication mode, connect air conditioner's HBS data interface. HBS interface exhibits no polarity (This interface is not yet available for Gree debugger and the monitoring software).
- (9) RS485 interface:When RS485 converter is under RS485 communication mode, connect air conditioner's RS485 data interface. RS485 interface exhibits polarity and terminal A and B are different.

3.3.2.4 Installation notice

- (1) Install indoors. To avoid collision, it is suggested to place it in the monitoring room together with the computer.
- (2) No need of power supply. Power is supplied through computer's USB interface.

3.3.3 Communication board

Communication board is mainly used for transferring data. Its functions are similar to a patching board. Provided that units are far away from the monitoring computer, communication board can be used for connection.

3.3.4 Communication cord

3.3.4.1 USB wire

Connect USB wire with computer's USB interface at one end and with the USB interface of USB data converter at the other end, as indicated below:

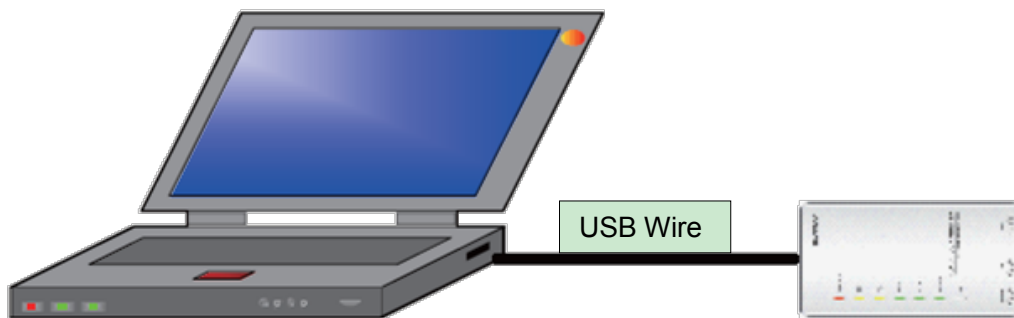

3.3.4.2 Board Connection Wire

There are 2 board connection wires supplied for the commissioning tool kits. One is 1 meter's long and the other is 5.5 meters' long. They are only different in length. One end of the wire shall connect with air conditioner's communication interface and the other end shall connect with CAN interface of Gree USB converter. As shown below, the wire can be connected to the communication interface of outdoor unit or the communication interface of indoor unit:

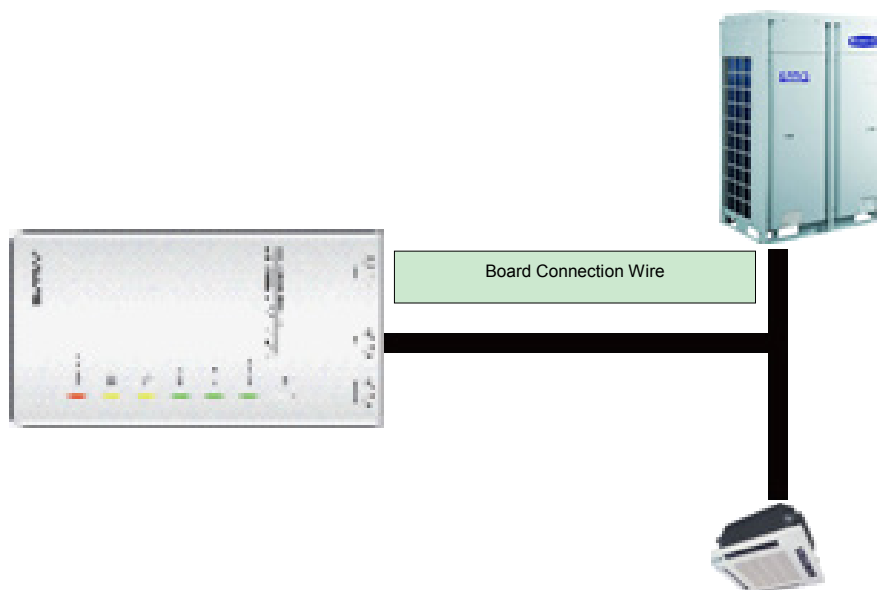

3.4 Software introduction

(1) One-button commissioning

Personnel responsible for the commissioning of air conditioners can start commissioning by pressing one button according to the commissioning logic of software, which will give the commissioning order to units. Then commissioning will be started up automatically step by step. During the commissioning, the corresponding process will be ticked in green on the software interface. If any commissioning process is not normal, it will be displayed in red.

(2) Comprehensive monitoring

The software can monitor every part of the air conditioning system, including functions, equipment and components operating status. The monitoring results will be displayed in text or curve so that user can acquire the operating status of the entire system conveniently and straightforwardly.

(3) Real-time control

Air conditioner's operating time and requirements may be different based on areas and functions. User can set units' parameters on computer according to actual needs, such as the on/off, temperature, fan speed, mode, etc. Meanwhile, the software can also set or view the function parameters of outdoor units, gateway and other equipment. In this way, the management of central air conditioners is realized.

(4) Replay history

Software can replay and save the historical monitoring information in the data base. The replay speed can be selected and the information will be shown in text or curve. This function has greatly saved the time to track problem cause and resolved the difficulty of problem reproduction.

(5) Applicable to multiple series, models and users

Gree Commissioning Tool Kits is applicable to air conditioning system that consists of multiple series and models. Later, it will be developed to cover all series of Gree central air conditioners, such as multi VRF, centrifugal chiller, screw type chiller, ground source heat pump units, modular units, fan coiled units, close control units, etc. It can be used by system and controller designers to develop and monitor units, or used for maintenance and commissioning.

(6) Other functions

For the convenience of users, the software has added functions like connection guide, printing screen, opening database folder, rebuilding database, changing database saving path, etc.

3.4.1 Software installation

3.4.1.1 Installation requirements

(1) Computer Configuration

| | |
|------------------|---|
| Memory | 1 GB at least 2 GB or above is preferred |
| Hard Disc | 10 GB available |
| CPU | Core 2 or higher 1 GHz at least 2 GHz or above is preferred |
| Operation System | Windows Server 2003 SP3 or higher Windows XP SP3 or higher Windows Vista Windows 7 |

(2) CD Playing

Make sure you have administrator access to the computer and there is a CD-ROM in the computer. Put the CD into the CD-ROM. If it's automatically running, then the following display will be shown. Or double-click the file "Launcher.exe".



For the first time to use Gree Commissioning Tool Kits, install these programmes: .Net Framework 4.0, USB Data Converter, Access Driver (necessary for versions below OFFICE 2007), Gree Debugger.

3.4.1.1 Installation flowchart

Button Graphics:

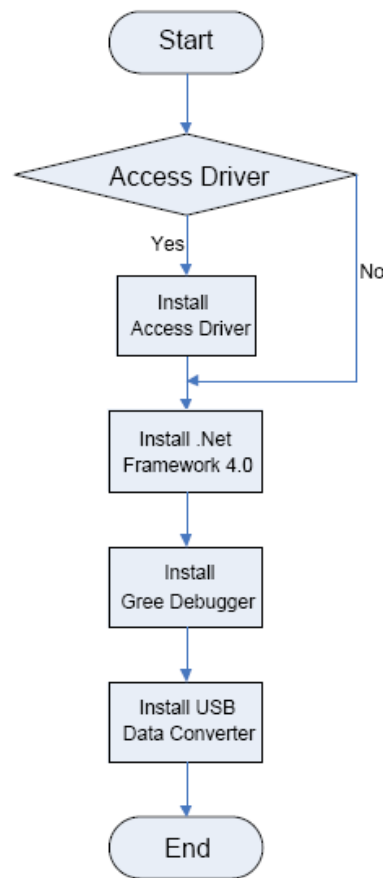

This flowchart describes basically the software installation process. See below for details.

3.4.1.2 Installation process

(1) Install .Net Framework 4.0

- 1) If your computer has installed .Net Framework 4.0 or versions above, there's no need to install again. Otherwise, click "Install .Net Framework 4.0".



2) Extracting files

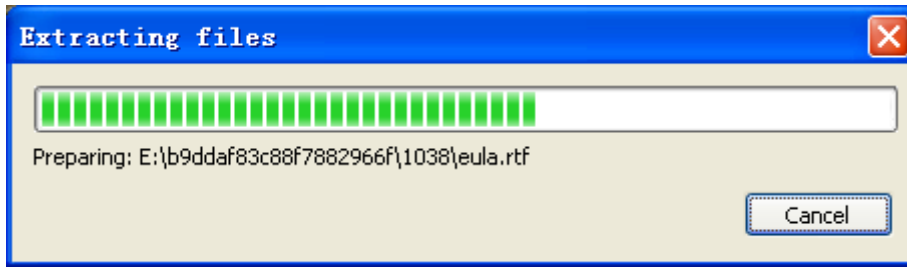

3) Click and select "I have read and accept the license terms". Then click "Install".

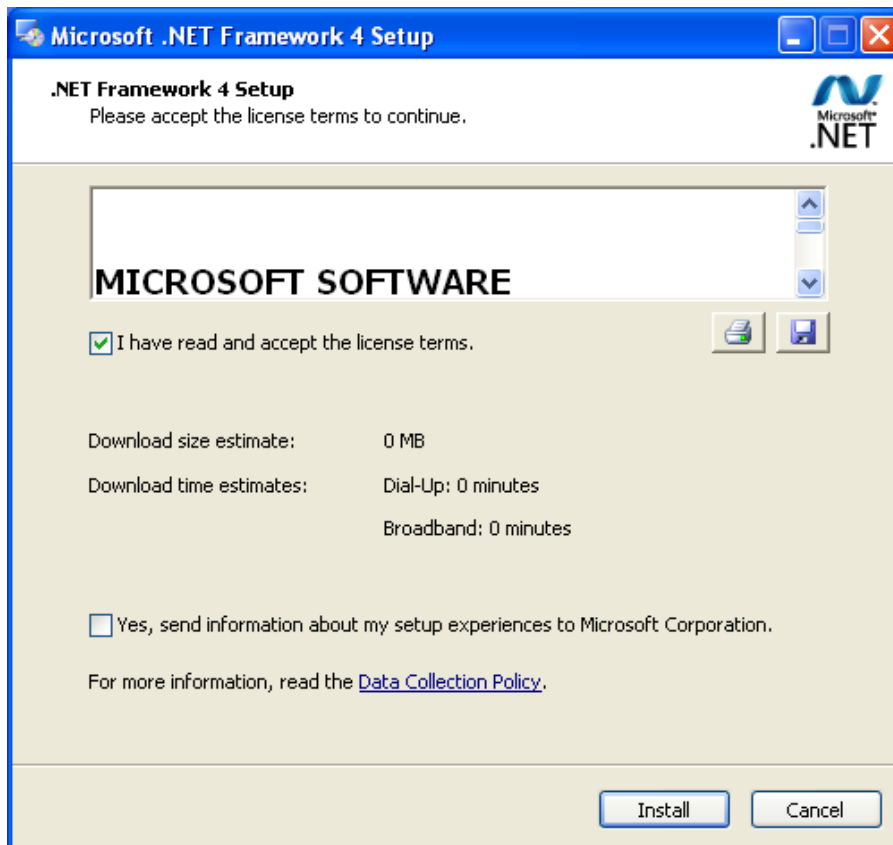

4) Installation is in progress.

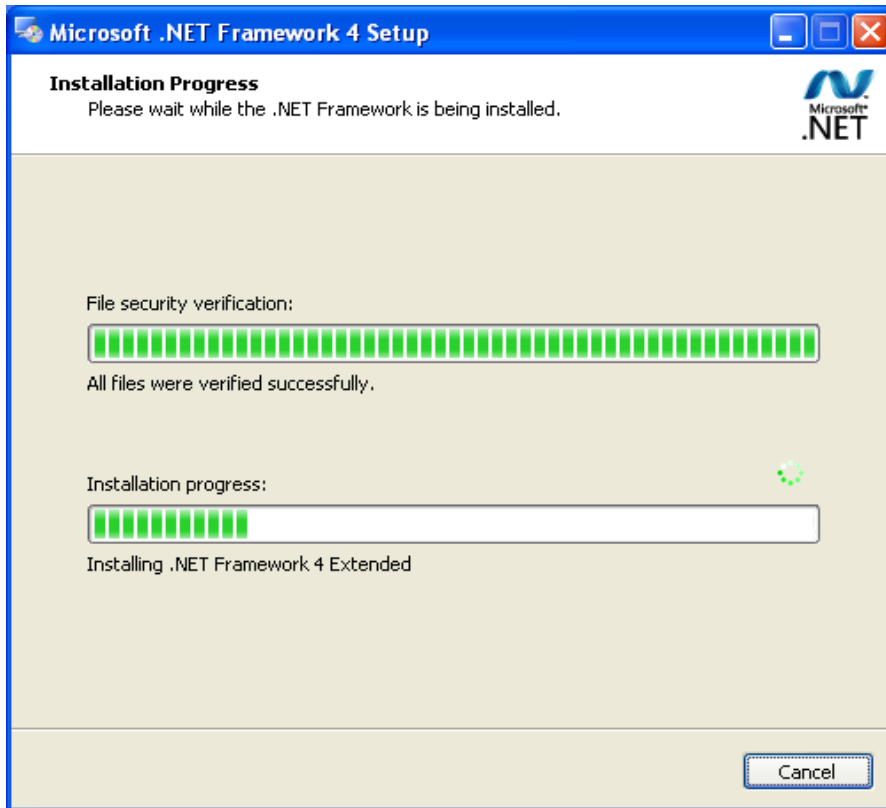

5) Click "Finish" to complete the installation.

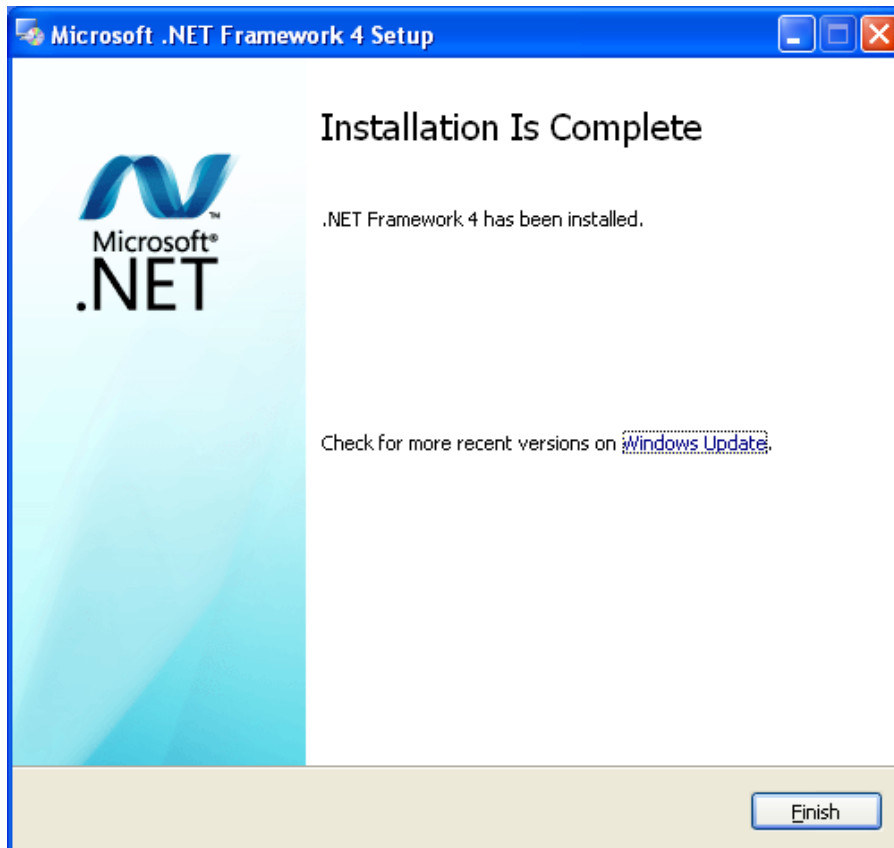

(2) Install Access Driver

- 1) Before operating Gree commissioning software, please first install Access Driver (necessary for versions below OFFICE 2007). Click "Install Access Driver".



- 2) Click "Next".

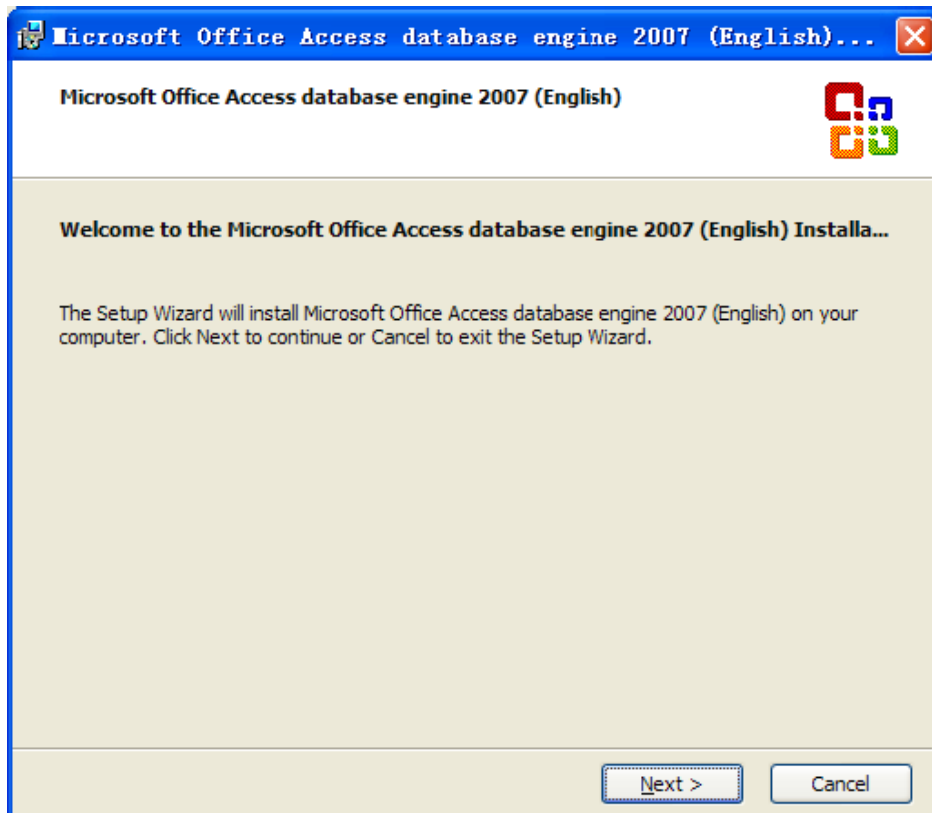

- 3) Tick "I accept the terms in the License Agreement" and then click "Next".



- 4) Click "Browse" to change the default folder to the expected one, or click "Install" to continue the installation.

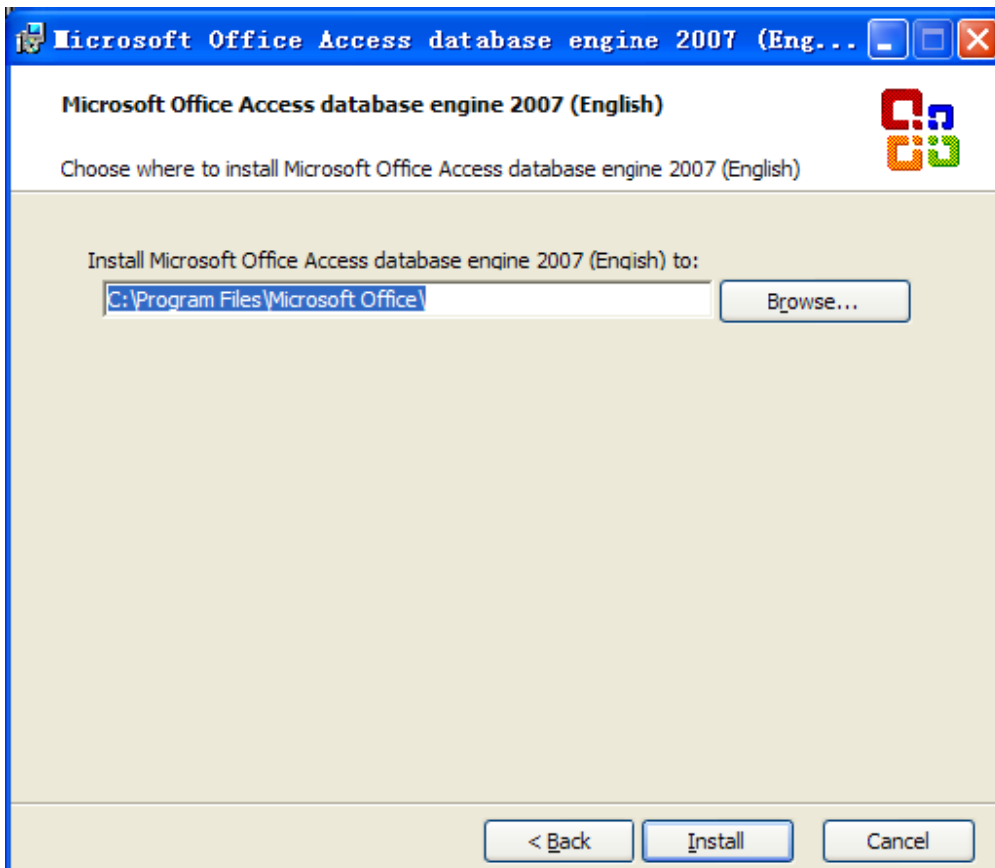

5) Installation is in progress.

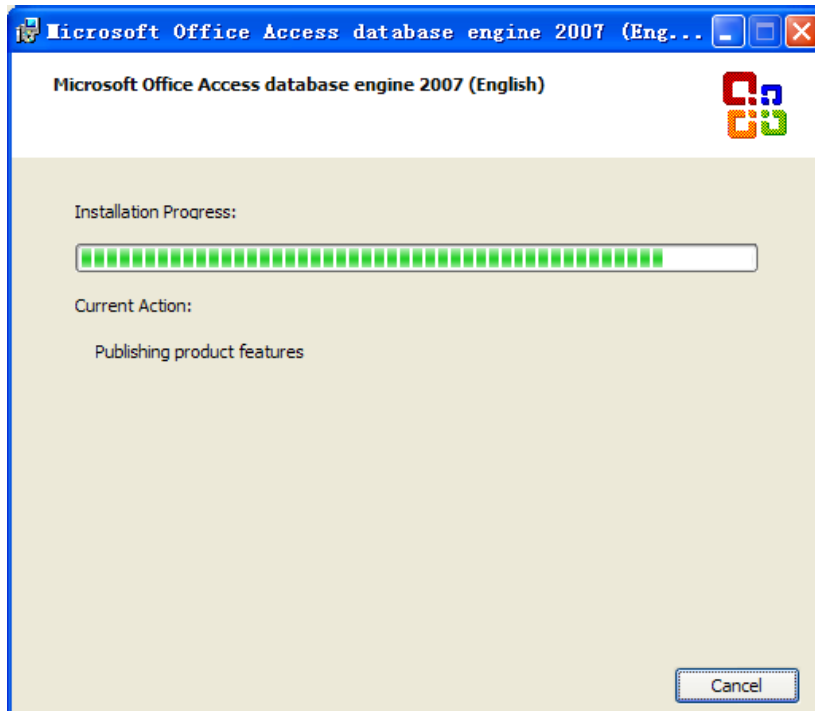

6) Click "Ok" to complete the installation.



(3) Install Gree Debugger

1) Before installing Gree debugger, make sure that your computer is installed with .Net Framework 4.0 or versions above. Then click "Install Gree Debugger".



- 2) Click "Next".

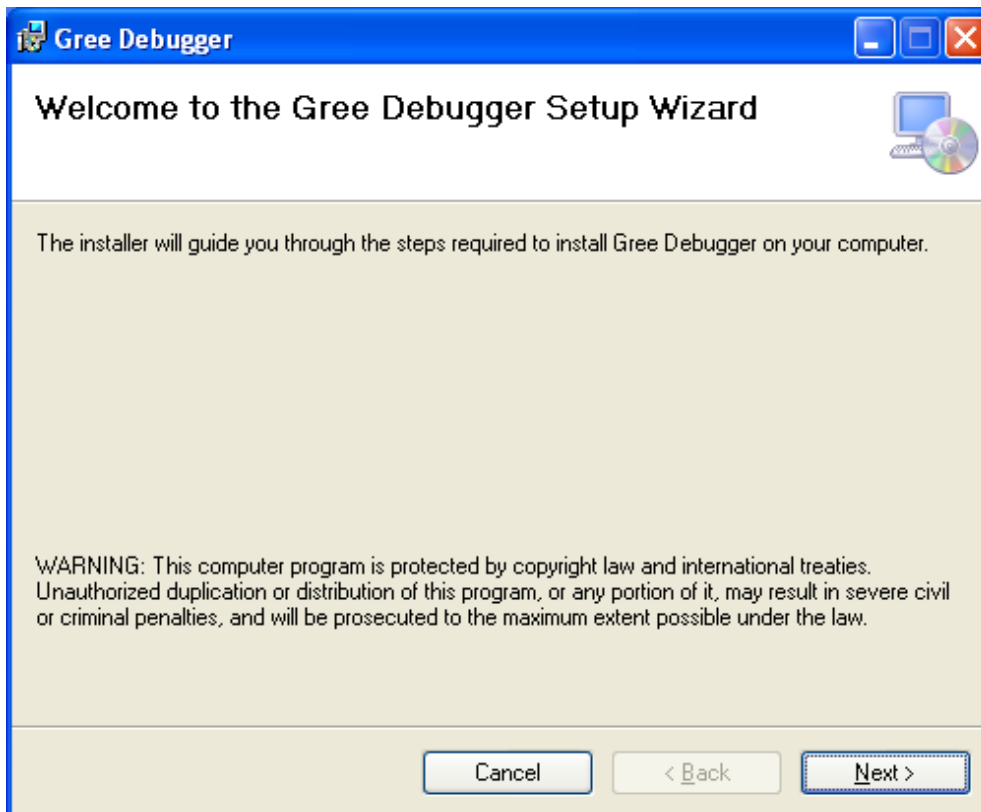

- 3) Click "Browse" to select installation folder. If no change is needed for the folder, click "Next" to continue the installation.

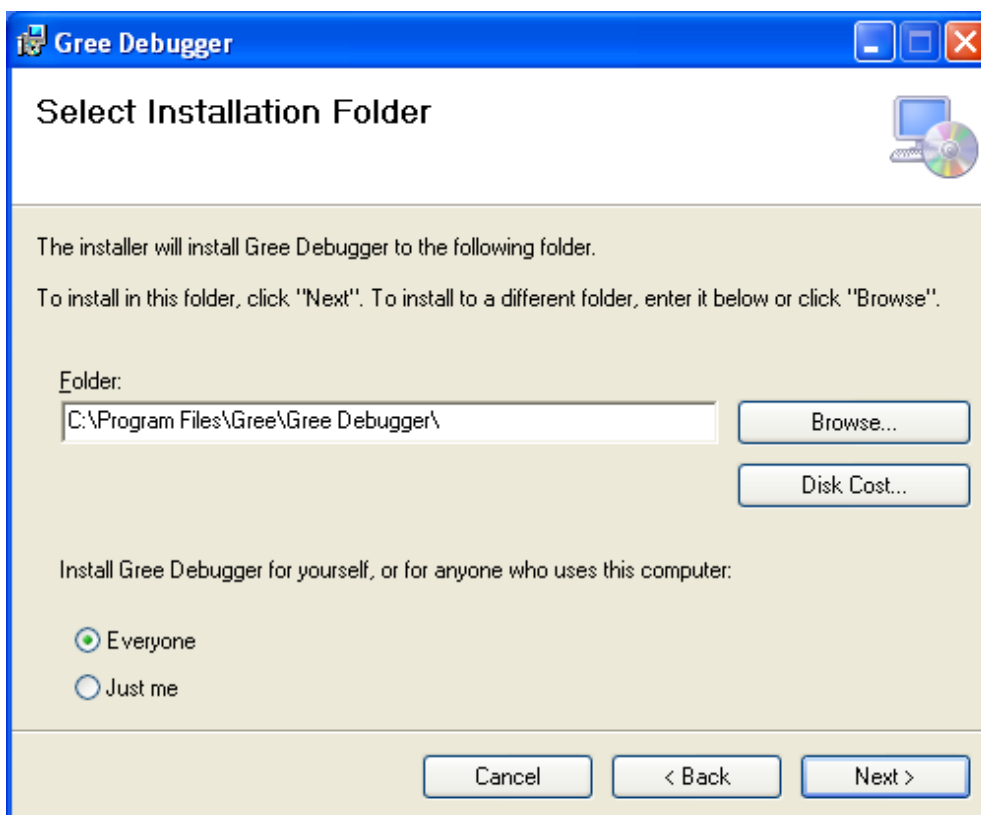

- 4) Click "Next".

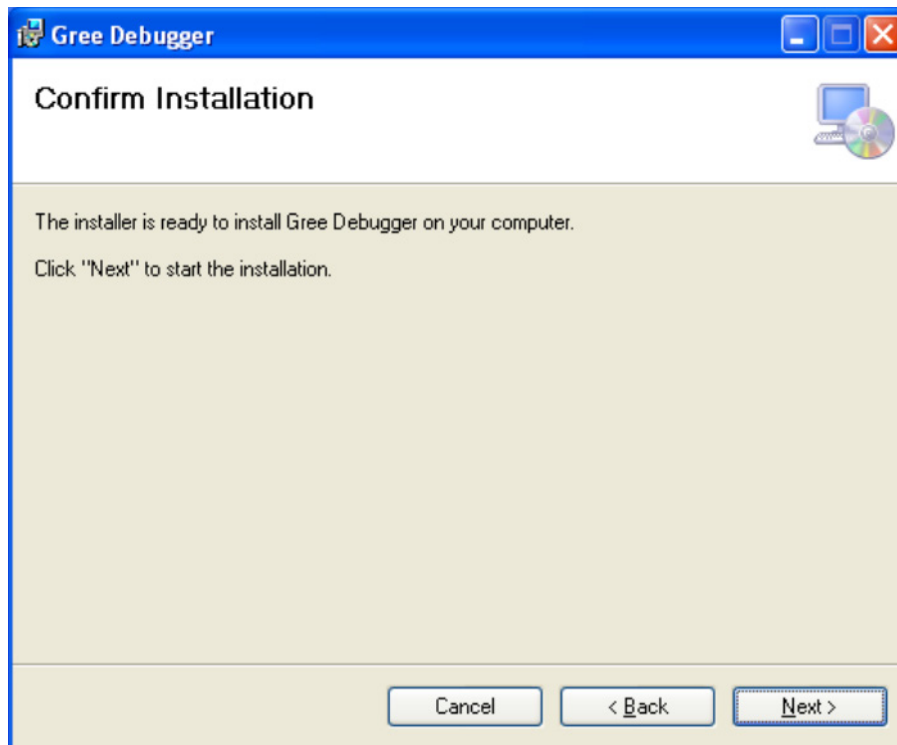

- 5) Installation is in progress.

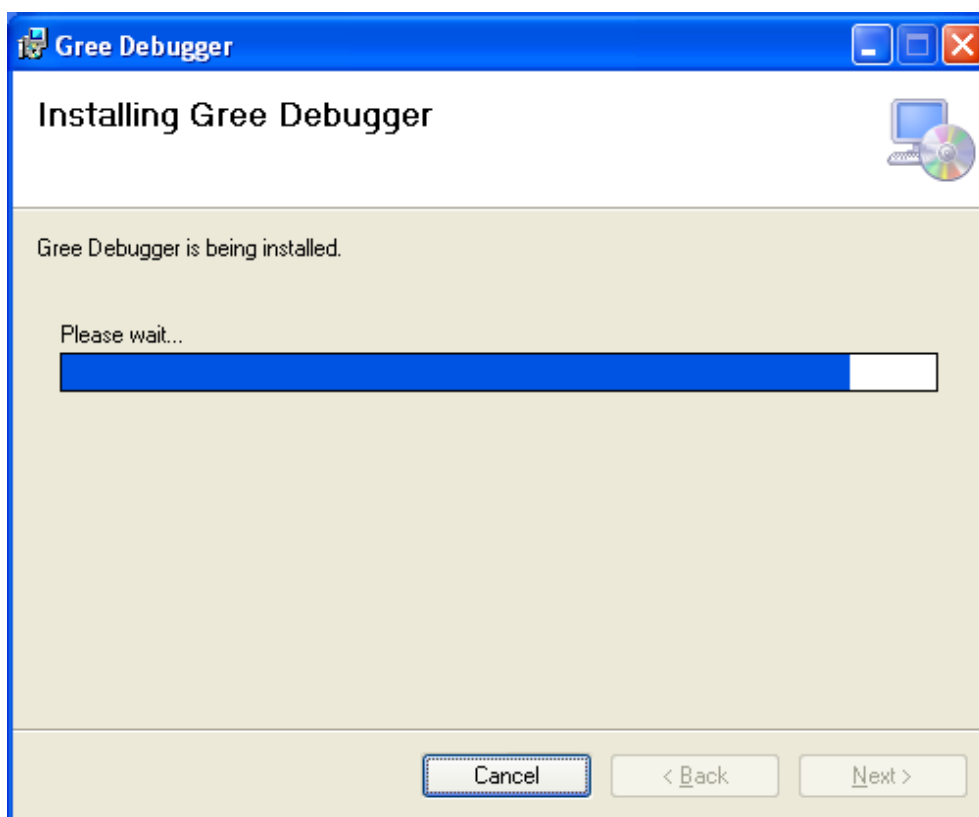

- 6) Click "Close" to complete the installation.

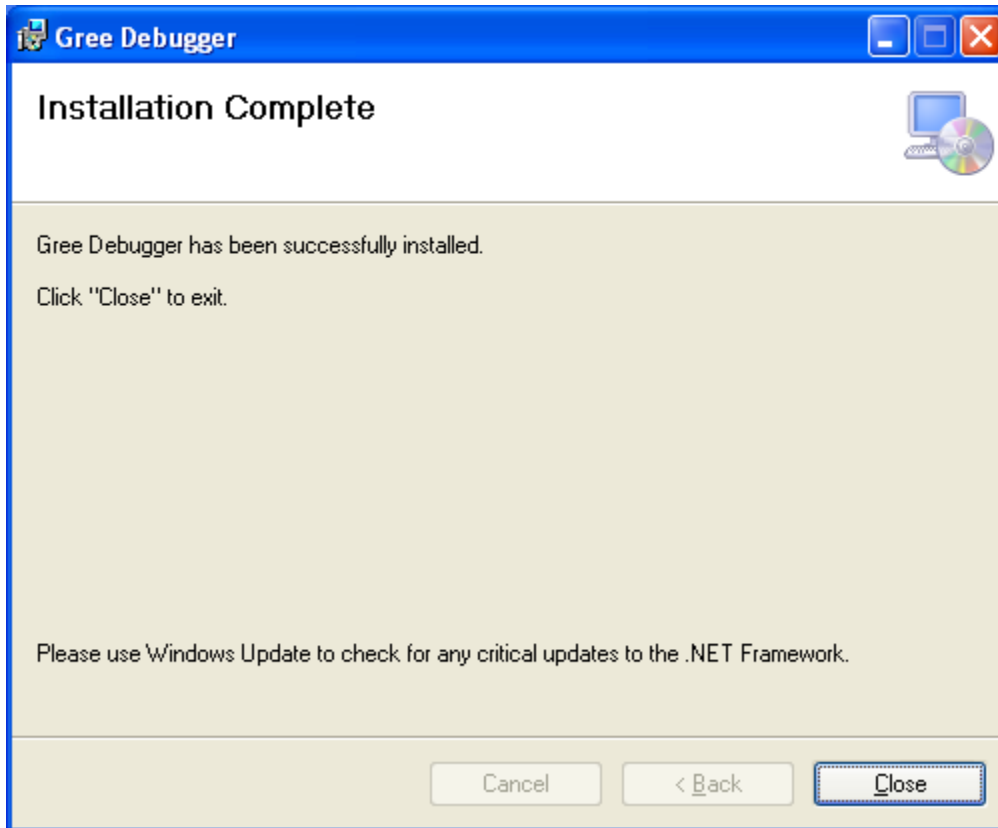

- (4) Install USB Converter Driver

- 1) If USB converter driver is already installed in your computer, this part can be skipped. Otherwise, click "Install USB Converter Driver".



2) Then the following installation window will be shown.

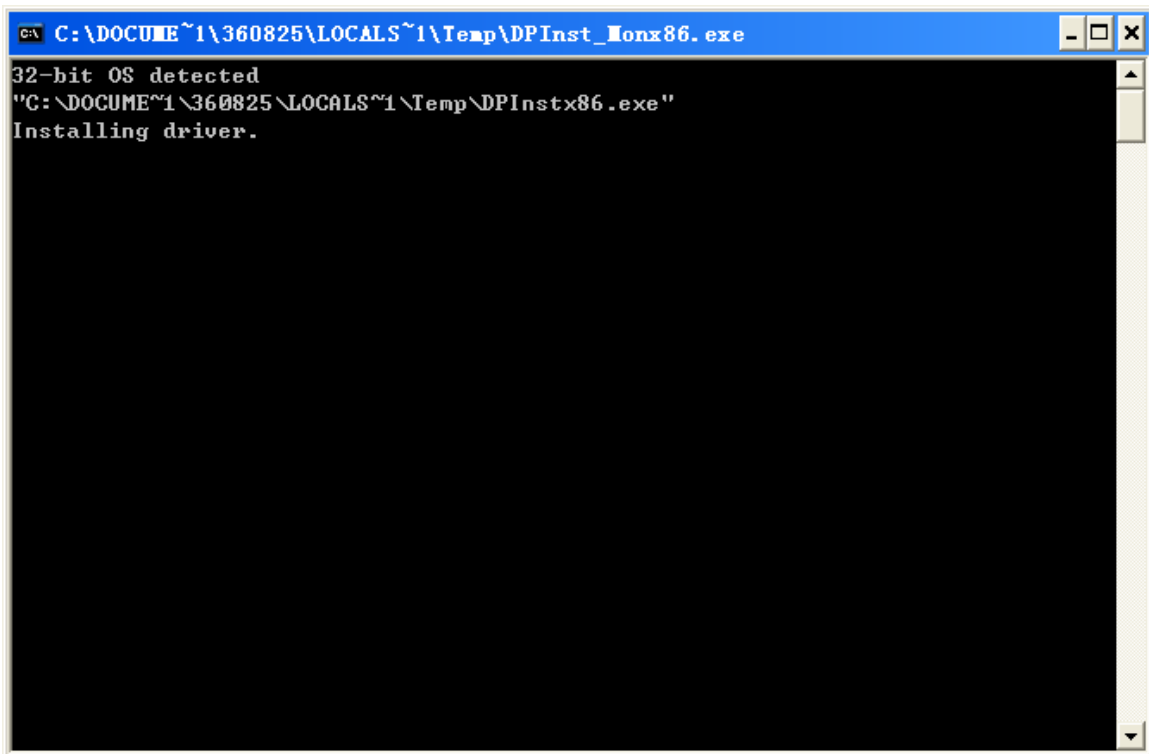

```
C:\DOCUMENTS\360825\LOCALS~1\Temp\DPInst_Monx86.exe
32-bit OS detected
"C:\DOCUMENTS\360825\LOCALS~1\Temp\DPInstx86.exe"
Installing driver.
```

3) This window will exit after installation is finished.

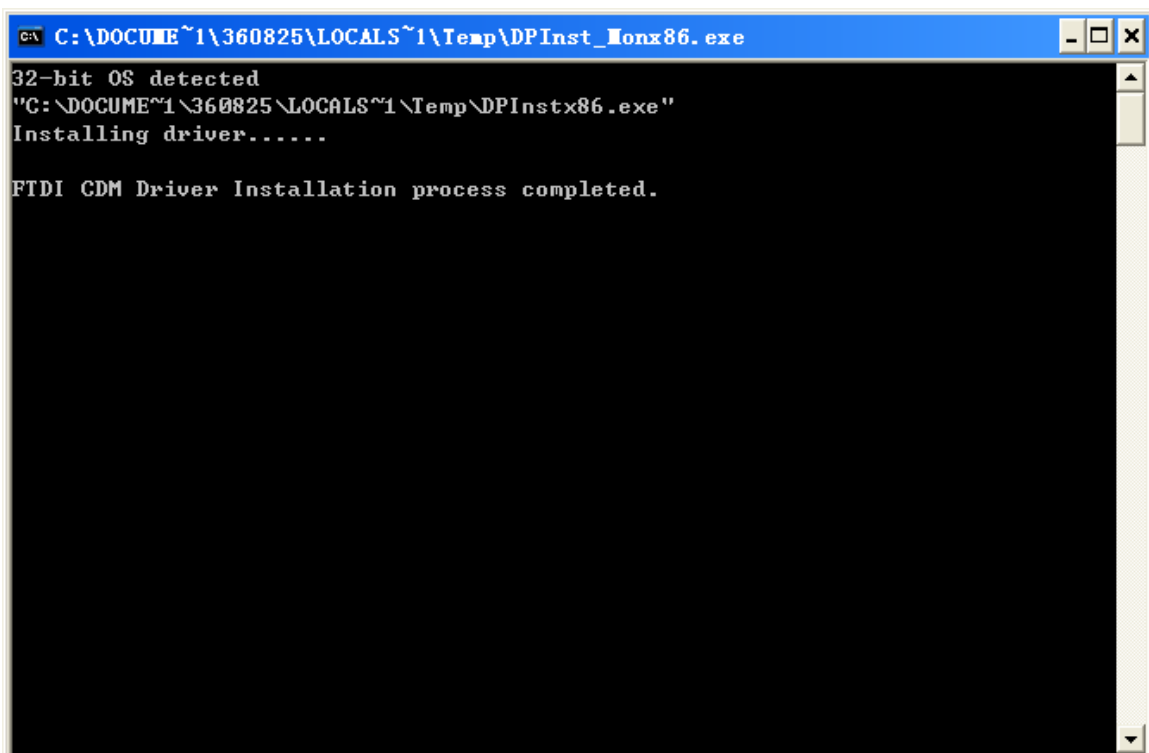

```
C:\DOCUMENTS\360825\LOCALS~1\Temp\DPInst_Monx86.exe
32-bit OS detected
"C:\DOCUMENTS\360825\LOCALS~1\Temp\DPInstx86.exe"
Installing driver.....
FTDI CDM Driver Installation process completed.
```

(5) Install Gree USB Data Converter

- 1) If converter baud rate is needed to be set, then converter configuring software must be installed. Click "Install Gree USB Data Converter".



- 2) Then select the setup language. You can choose Chinese "simplified", Chinese "traditional" or English. Then click "OK".

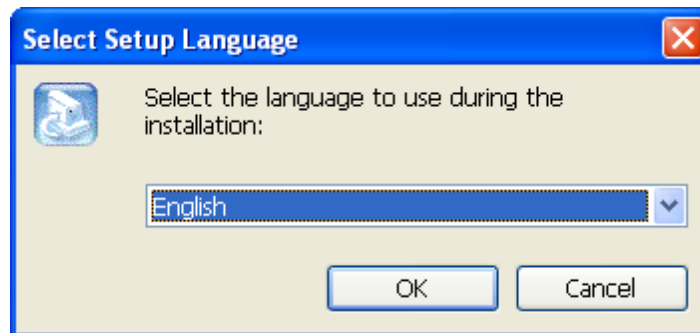

- 3) Click "Next".

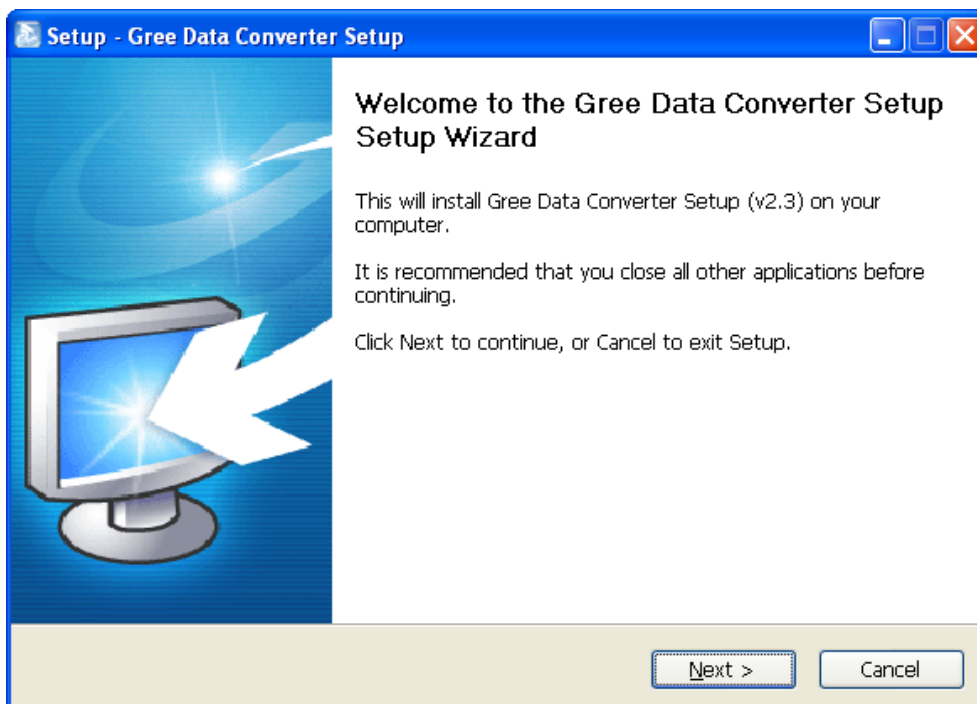

- 4) Tick "I accept the agreement". Then click "Next" to continue installation.

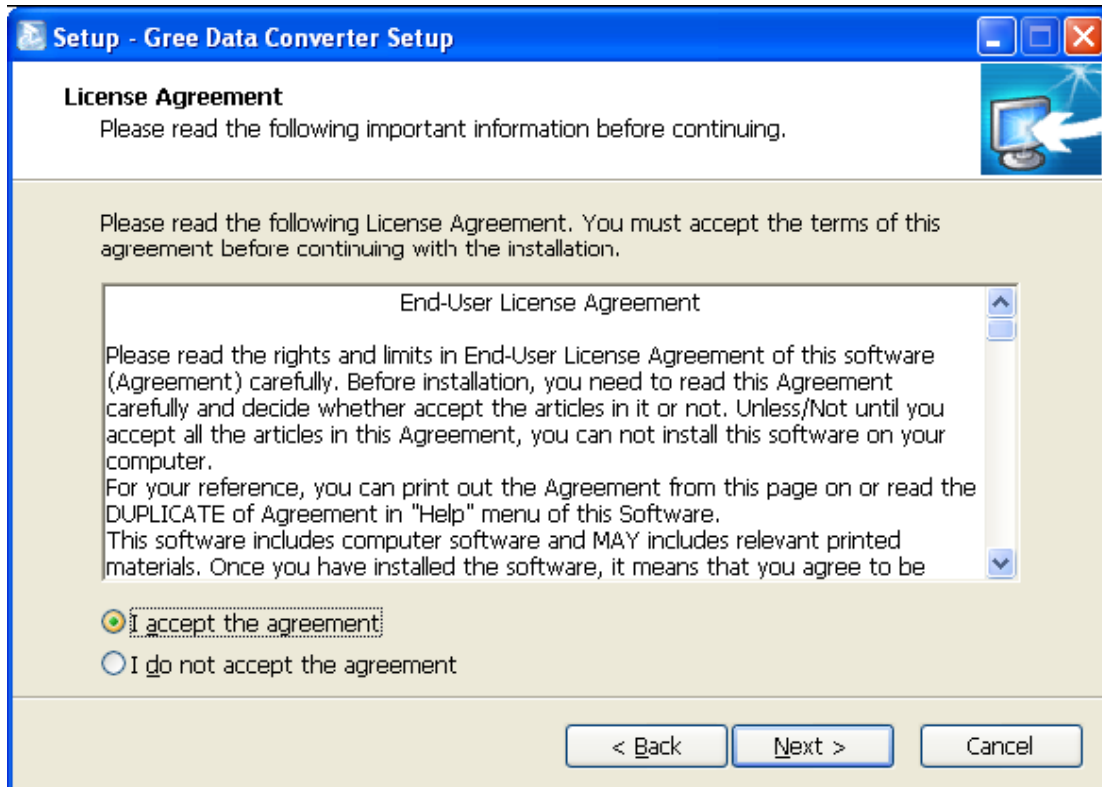

- 5) Click "Browse" to select your expected installation folder. Click "Next" to continue.

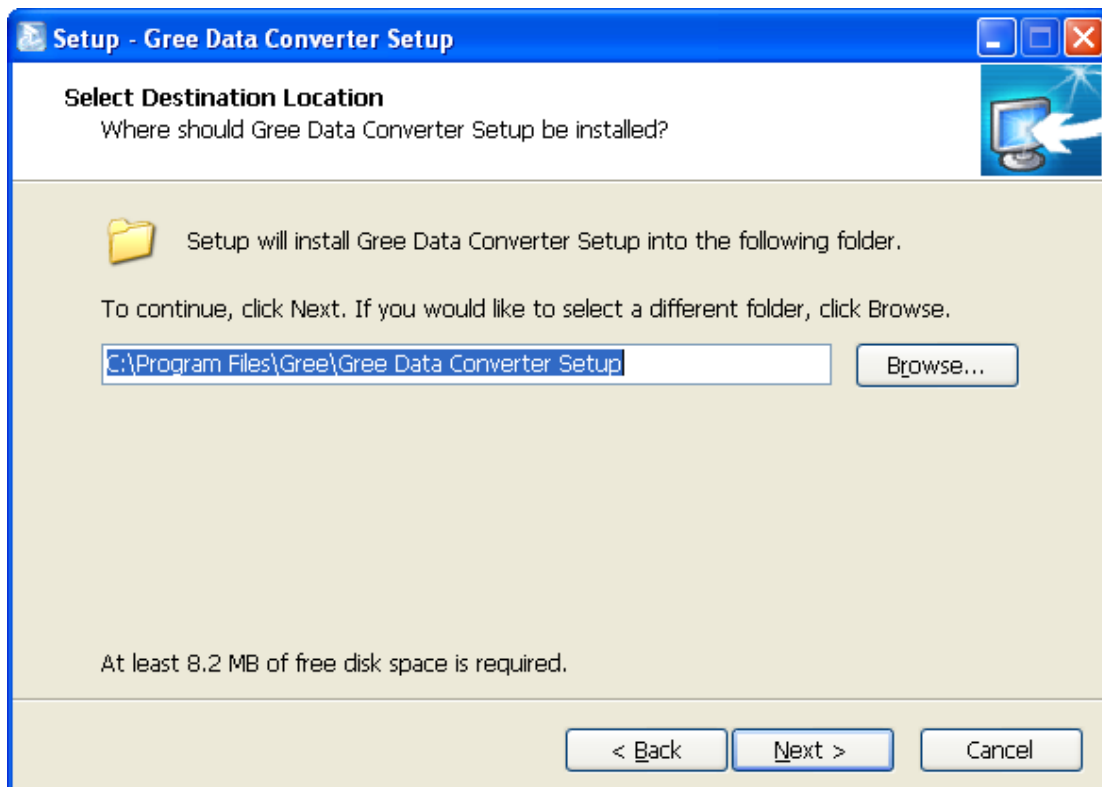

6) Click "Browse" to change folder. Click "Next" to continue.

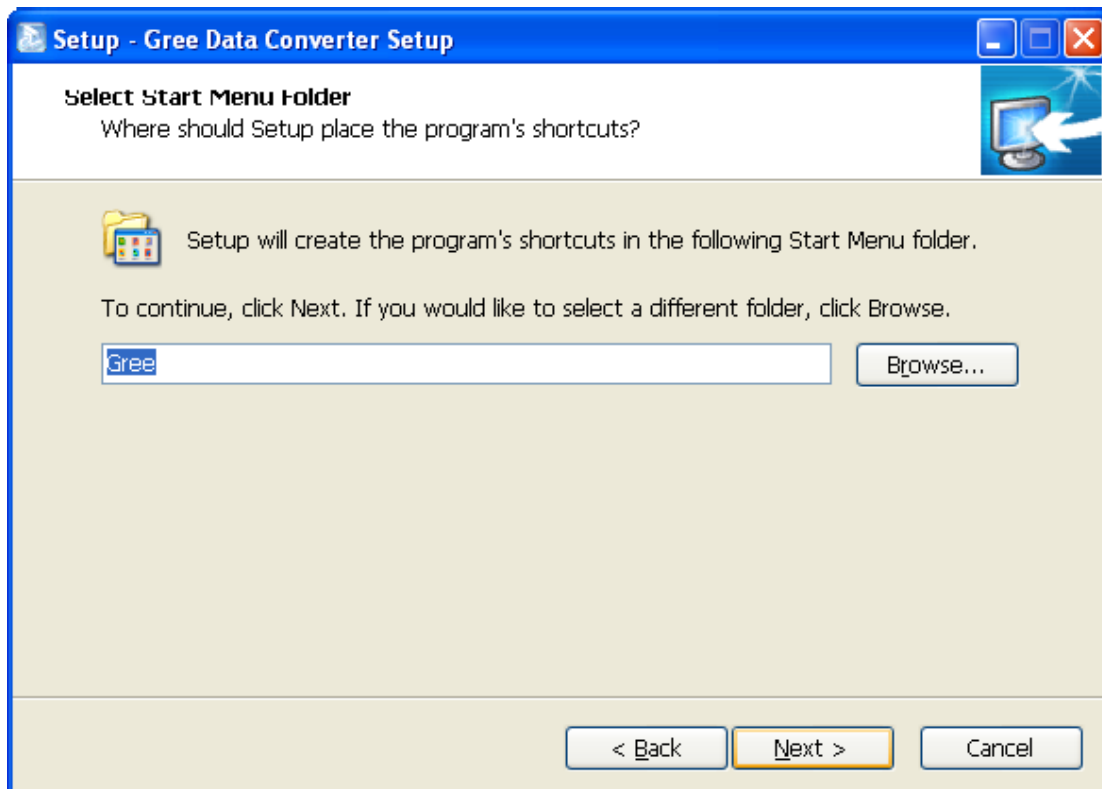

7) If you want to create a desktop shortcut, tick "Create a desktop icon". Then click "Next" to continue.

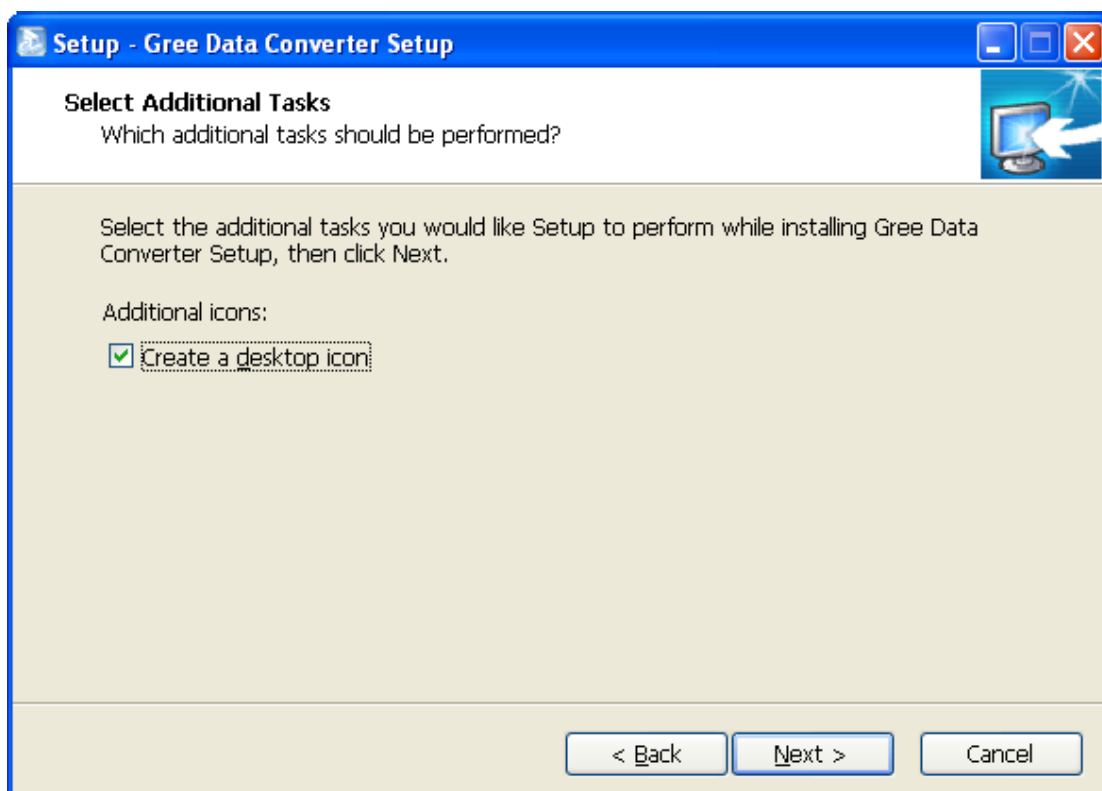

- 8) Destination location, folder and additional task will be shown in the next step. If you need to change any of it, please click "Back". If not, click "Install" to start installation.

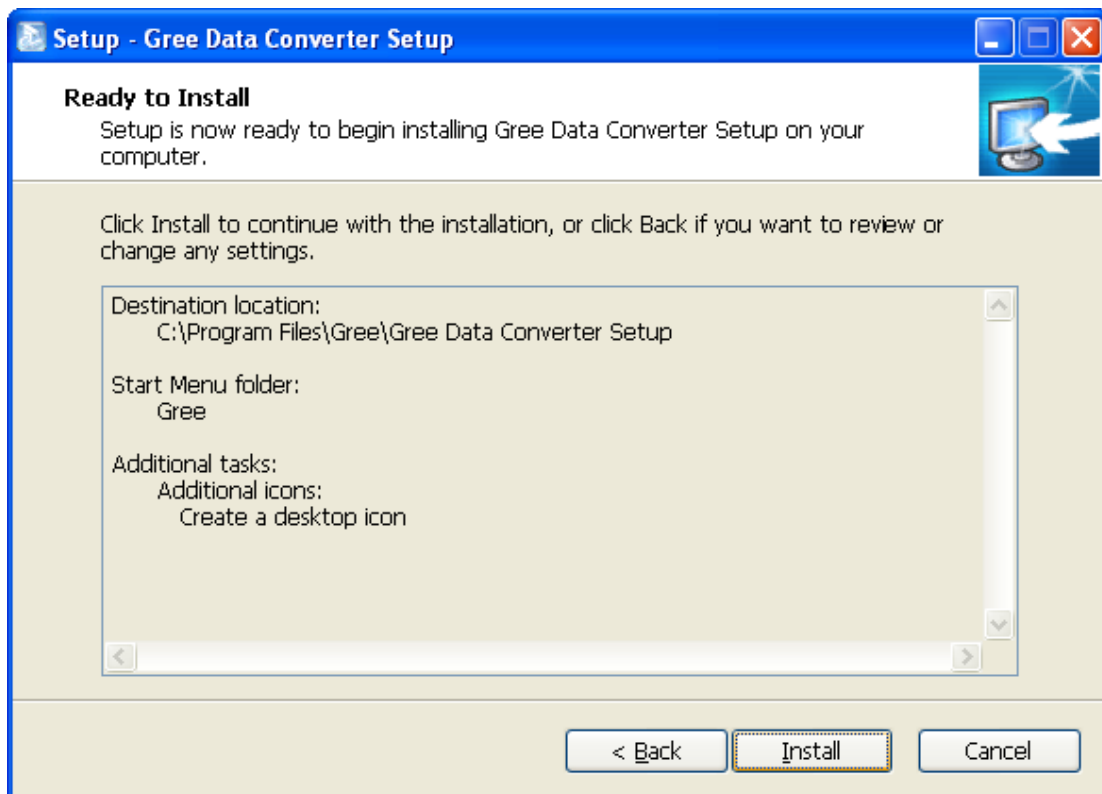

- 9) Installation is in progress.

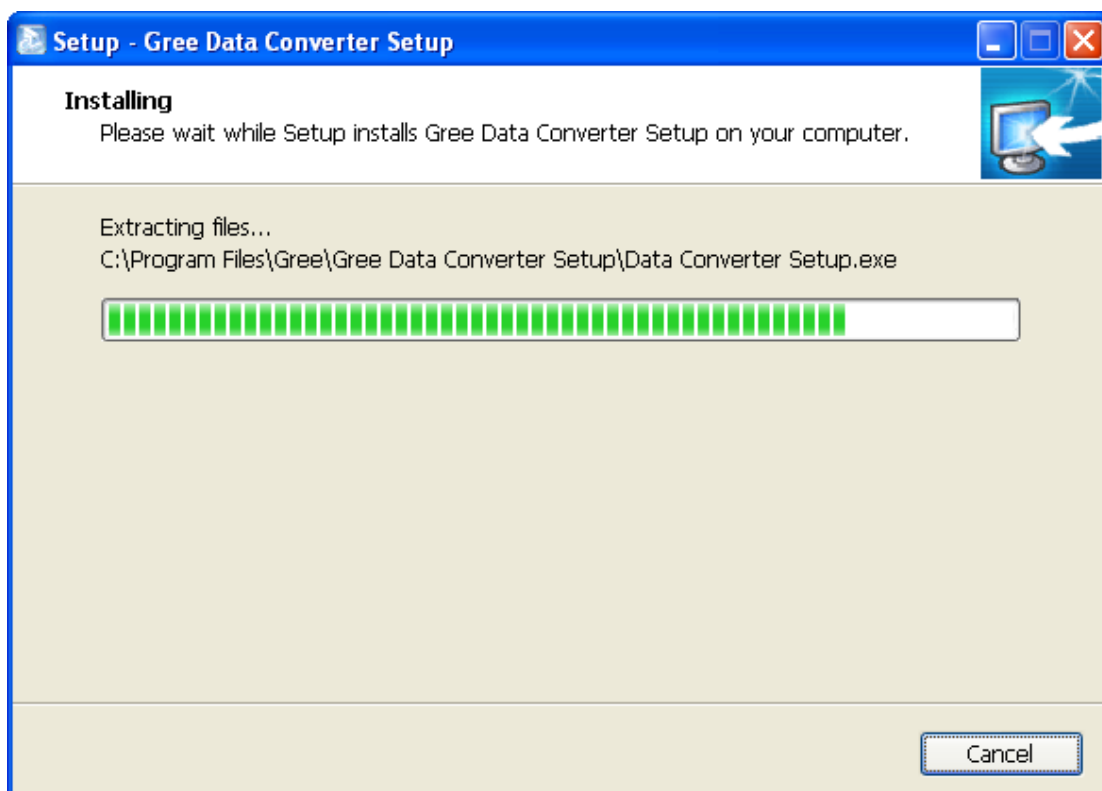

- 10) Click "Finish" to complete the installation.

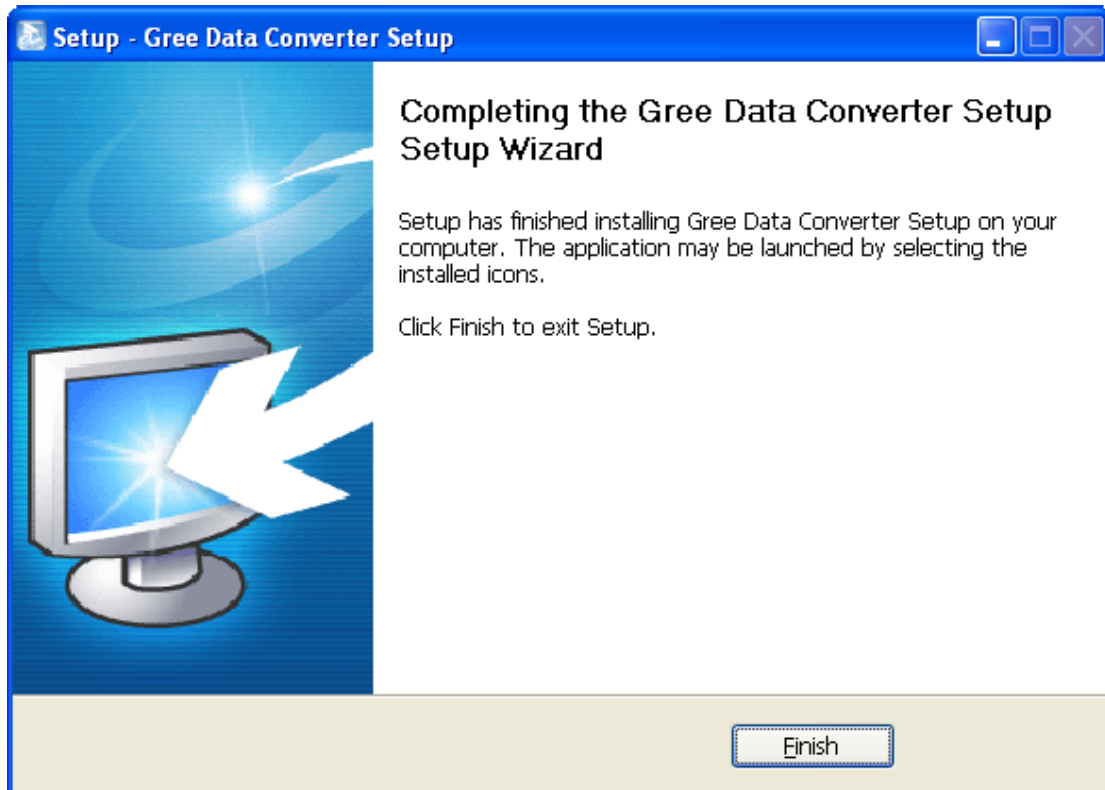

3.4.2 Data monitoring

- (1) Start up Gree Debugger.



- (2) On the original interface, user can select language and units system. Click "OK" to confirm the defaulted language and units system and start up the software.

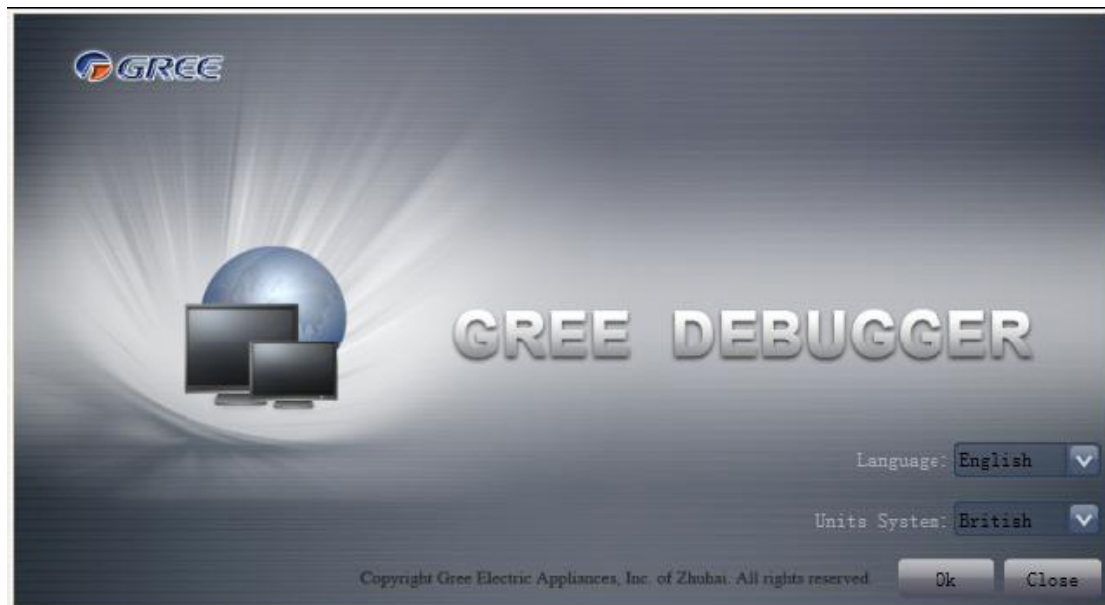

(3) Select language.

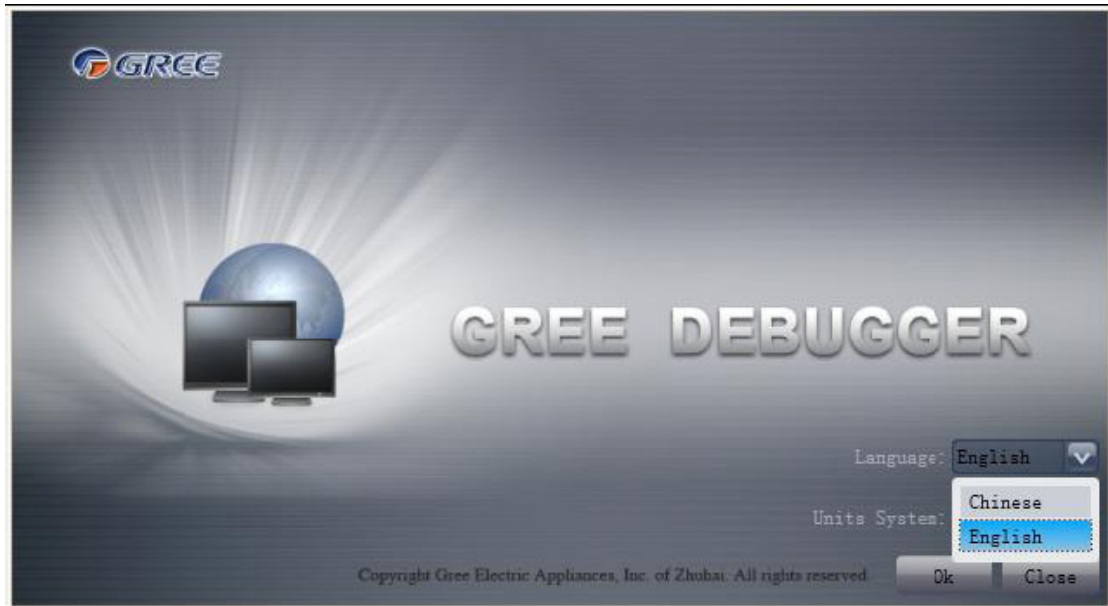

(4) Select system of units.

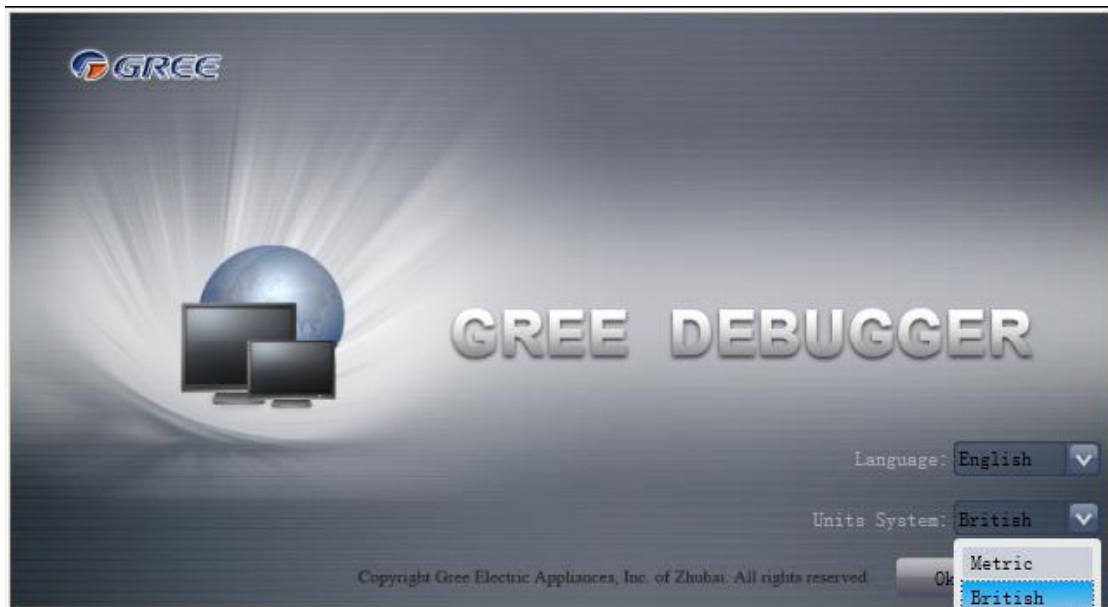

- (5) If units you want to monitor are already connected, and able to communicate normally, with correct COM and protocol, then you may click “Connect” to enter the interface of numbers. Otherwise, connect in accordance with the connection diagram shown below.

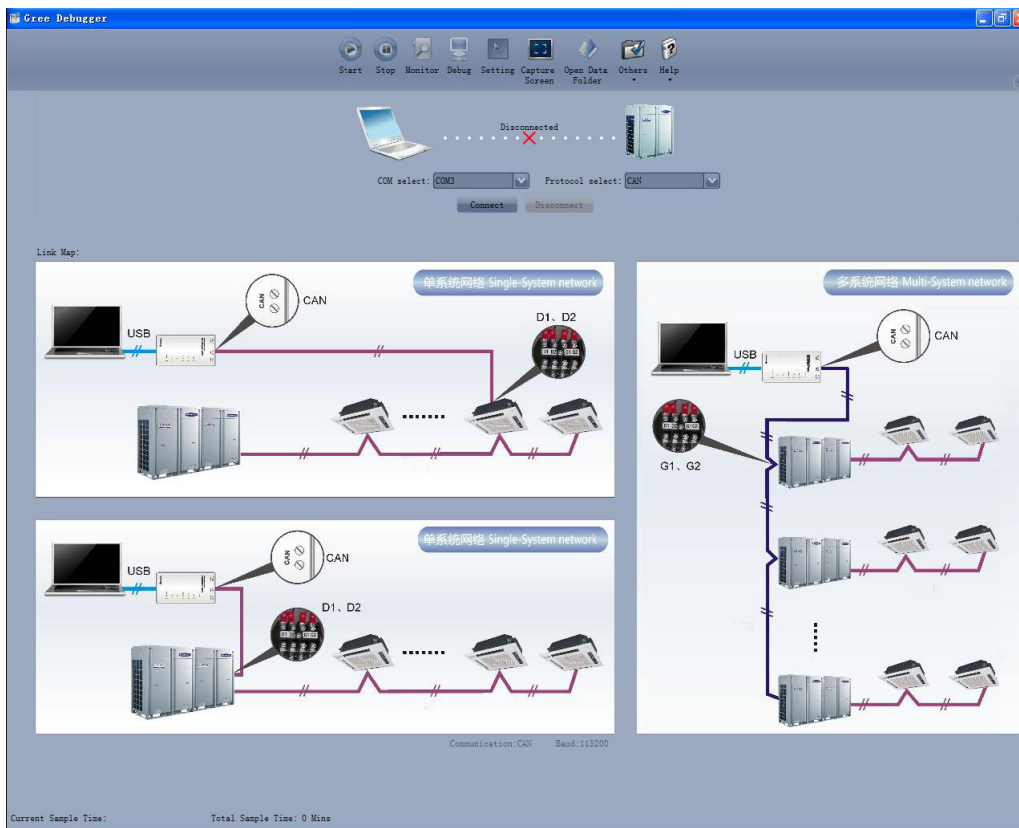

- (6) COM selection: the serial port in your computer can be detected automatically. You just need to select your desired serial port.

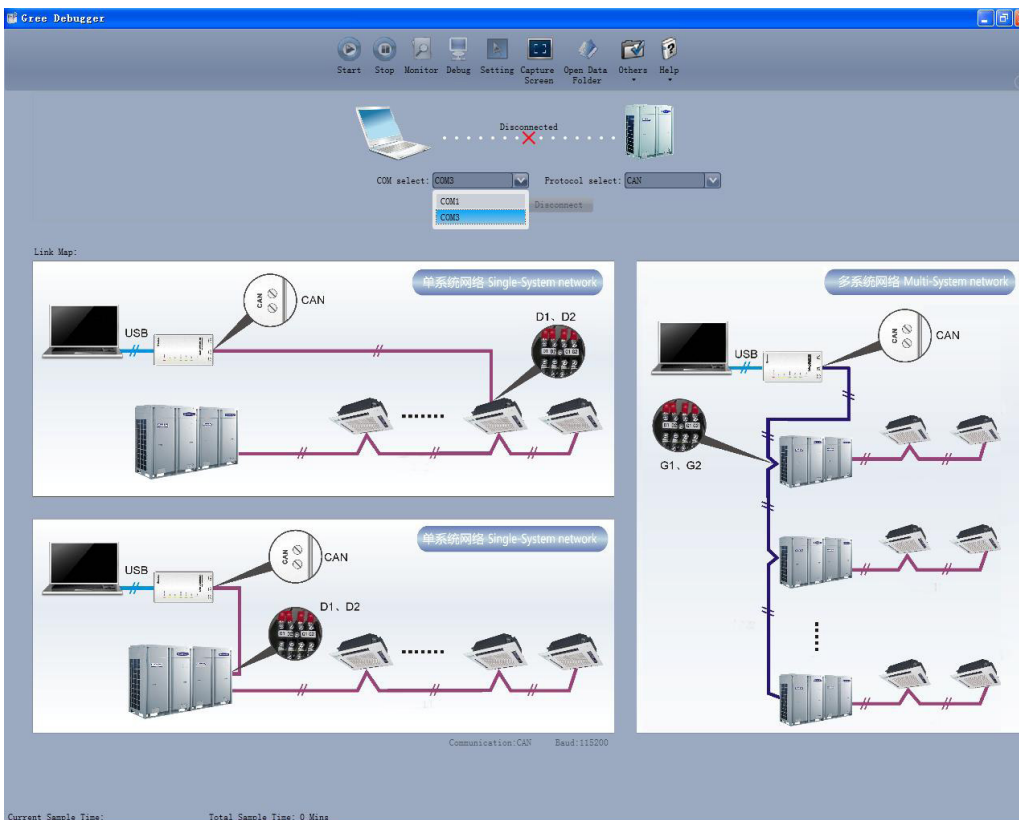

- (7) Protocol selection: This is to select the communication method of your units. Currently, CAN is applicable to the units.

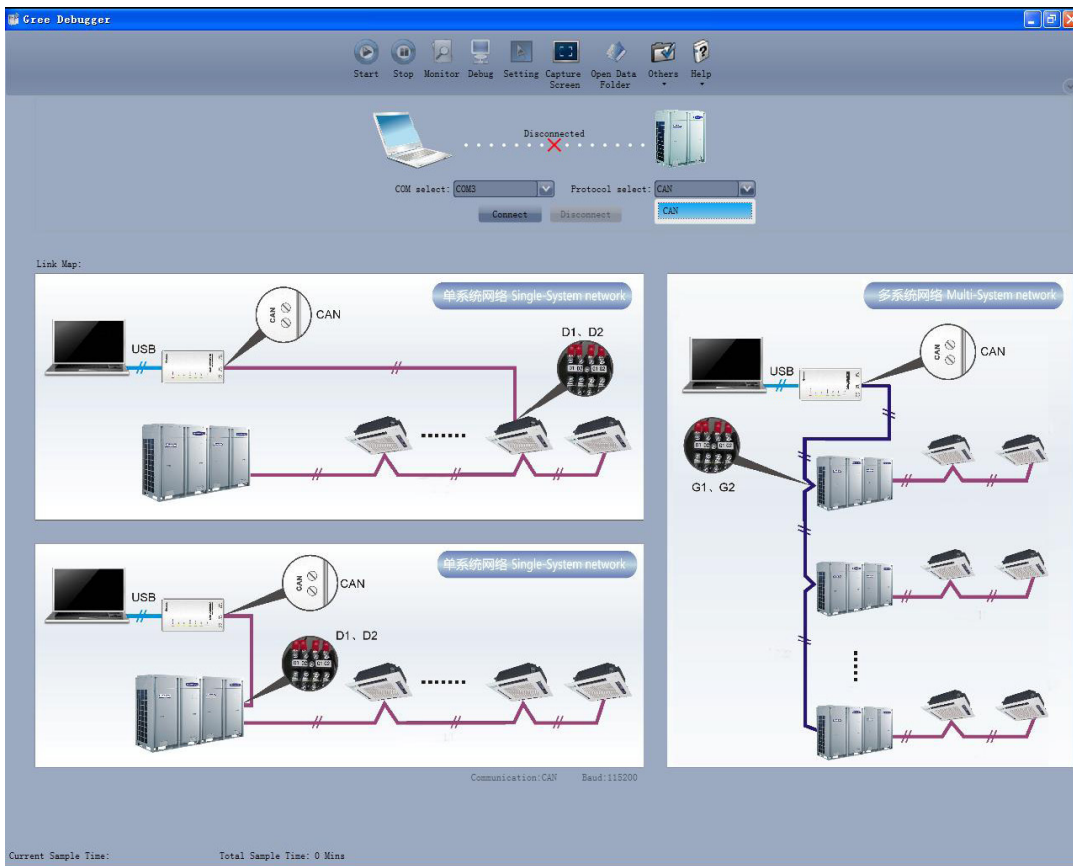

- (8) After the selection, click “Connect”. If units can communicate normally with computer, then the interface of numbers will be shown. Otherwise, “Connecting” will be shown.

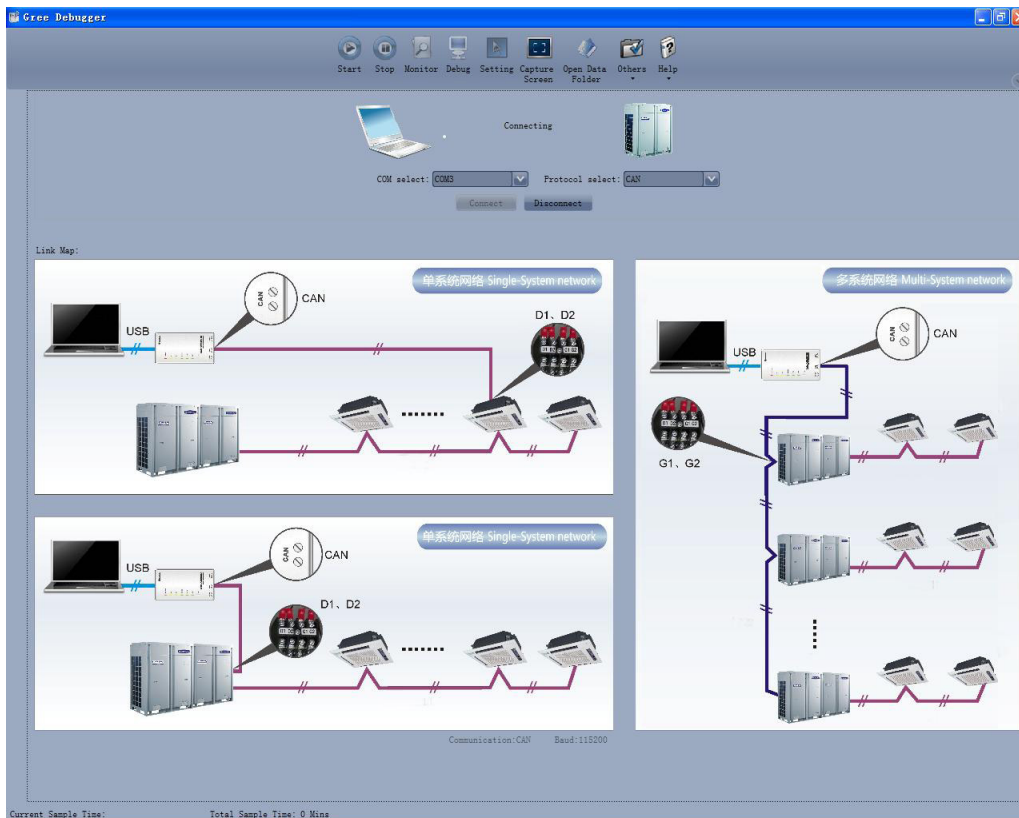

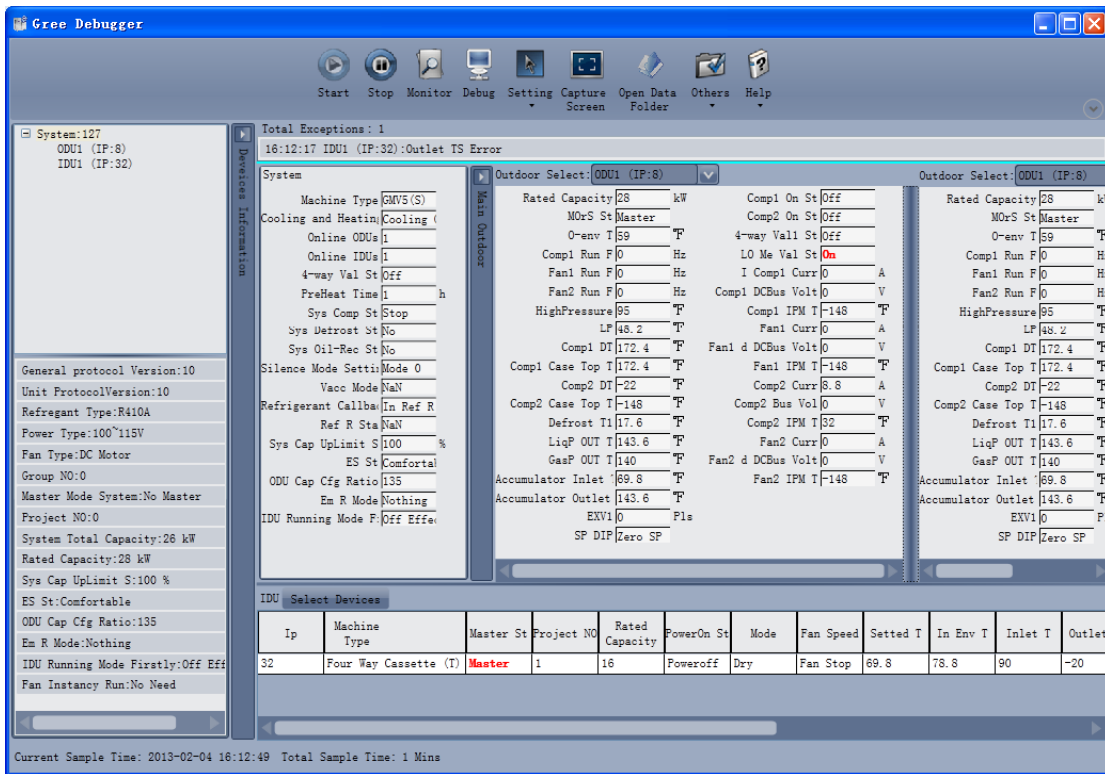

(9) There are several display zones on this interface. You can hide devices information and system information by clicking devices information icon and system icon . Display zones of indoor unit information and errors can be dragged up and down at the dividing lines. As to the display zone of outdoor modules information, it can show information of only one module and hide information of others (two modules are defaulted to be shown). Menu bar can be hidden by clicking icon . Status bar shows the current time and period for data collection.

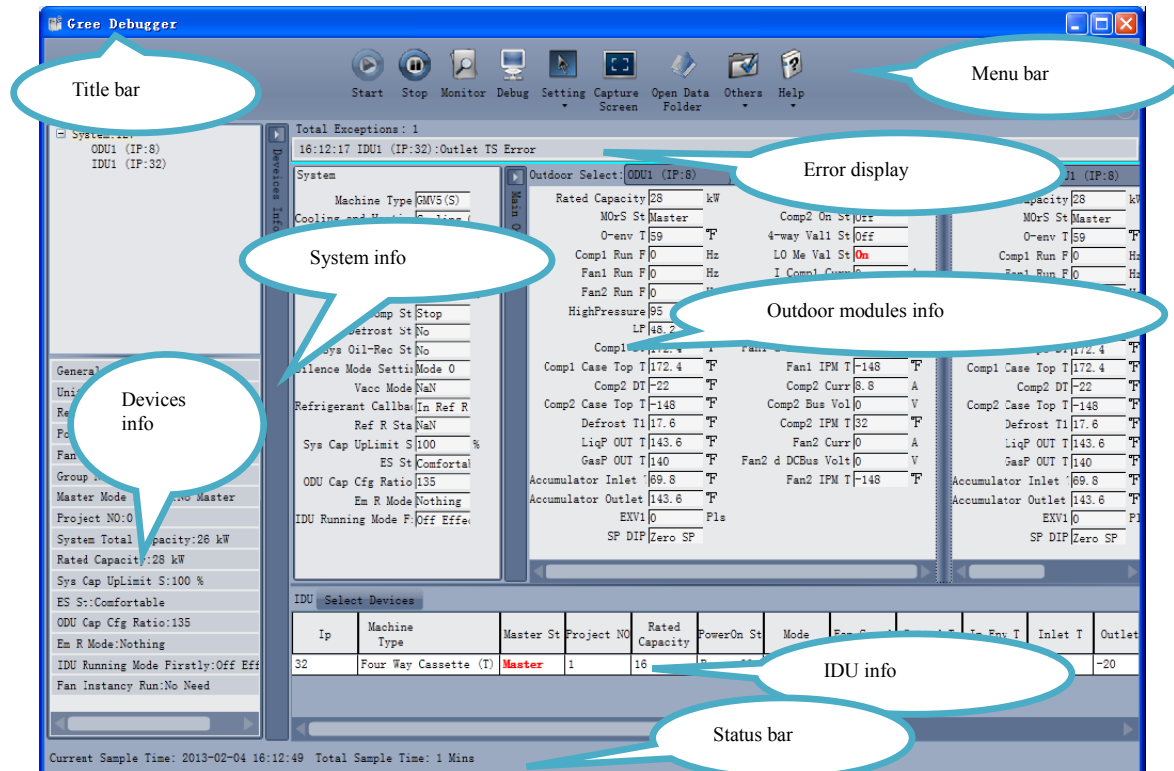

- (10) On the display zone of devices information, you may click to select and view units that need Monitoring.

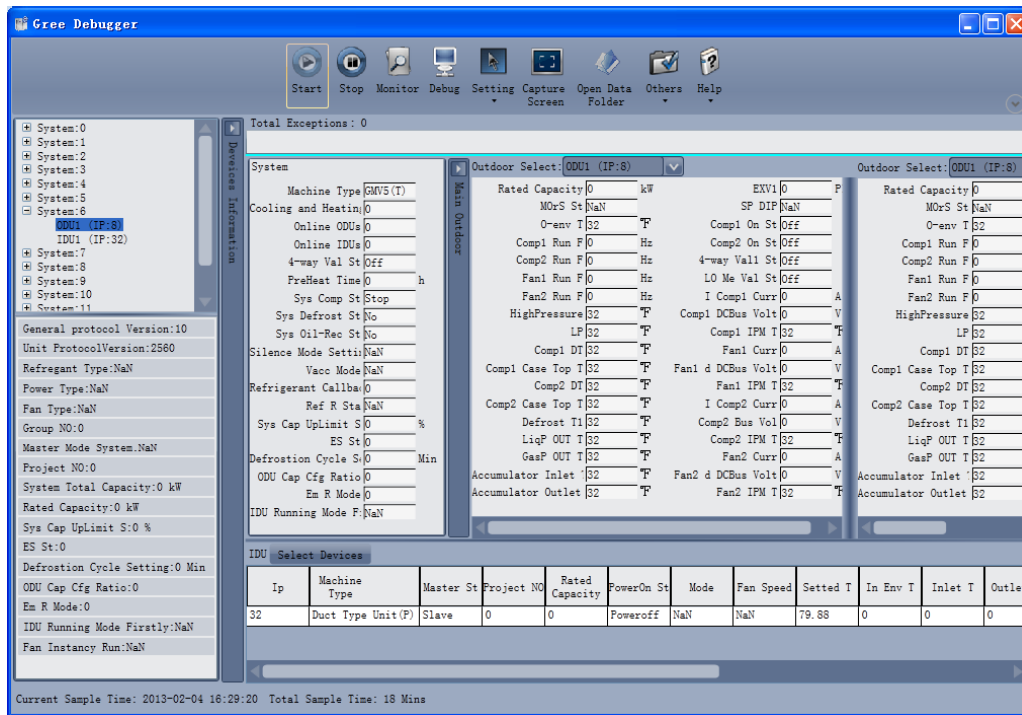

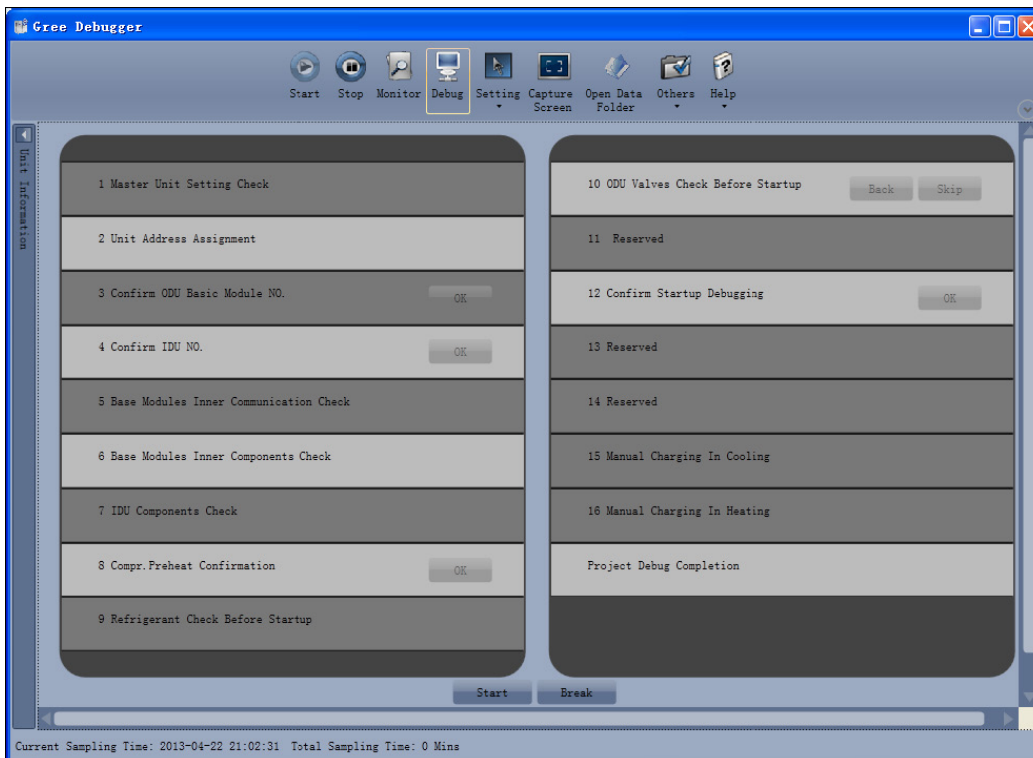

3.4.3 Project debugging

- (1) Click icon of "Debug" on the menu bar and the interface will be switched to project debugging, where auto debugging will be started from up to down and from left to right. Note: Debugging function is only applicable to a single-system network.



(2) Click “Start” to enable the debugging function. Then debugging will be started up automatically.

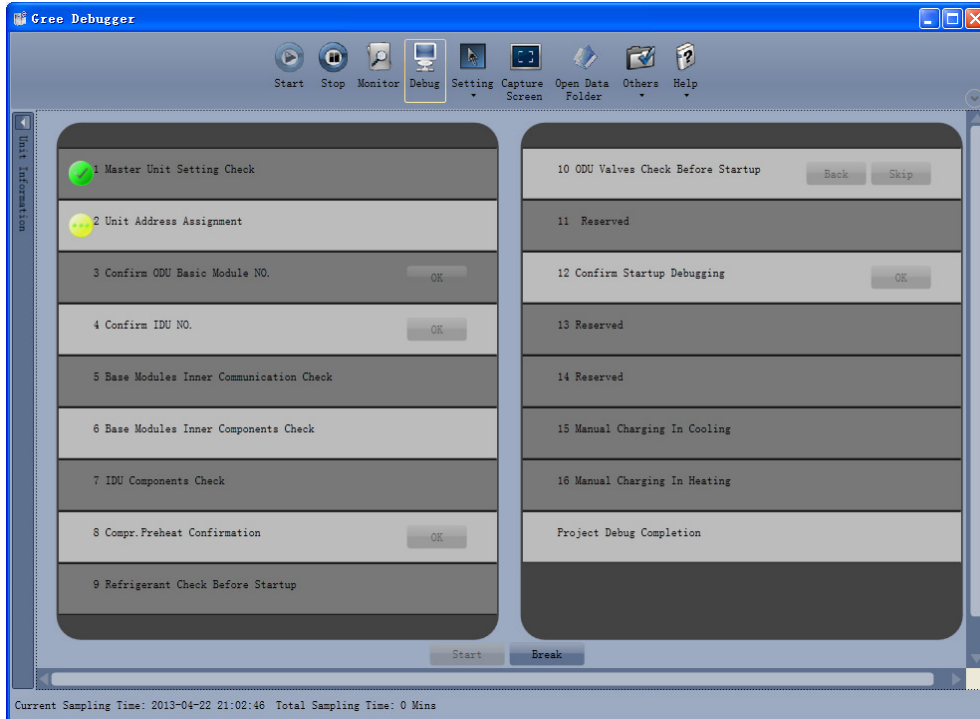

 indicates that debugging is in progress while  indicates debugging is completed.

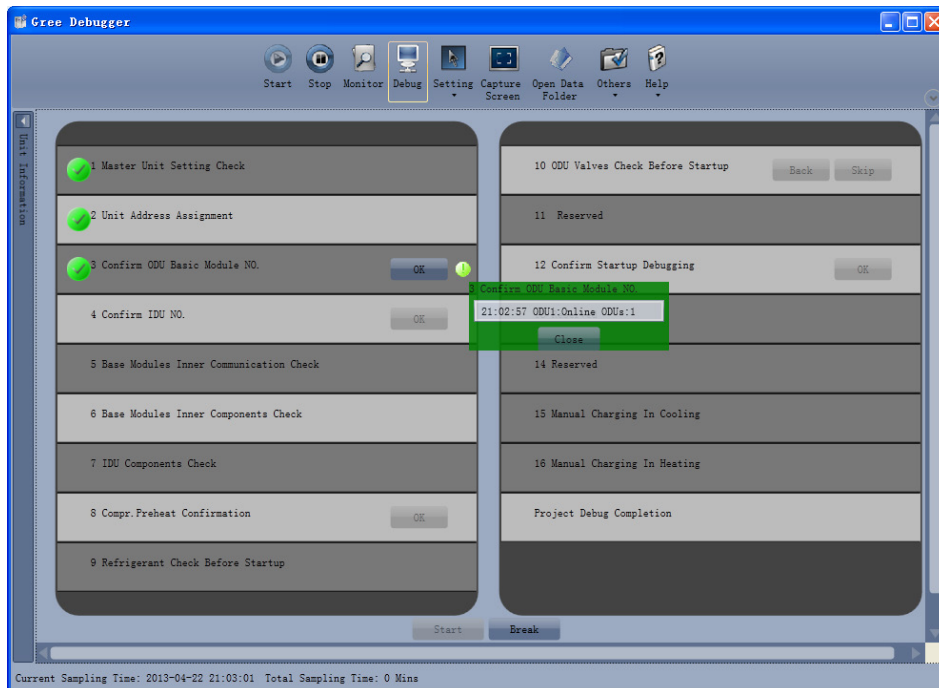

(3) If “OK” button is displayed, it means user needs to judge whether to continue debugging or not.

Click icon  and relevant information will be shown for your reference. Click “Close” to close the pop-up (For No.3 Confirm ODU Basic Module NO. and No.4 Confirm IDU NO., the current number of units under debugging will be displayed. See the following marked with circle. For No.8 Compr. Preheat Confirmation, the preheat time will be displayed. See the following marked with circle).



- (4) Icon  indicates that there is problem found during debugging. Debugging will not be completed unless problem is solved (after problem is solved, step without “OK” button will switch to the next step automatically, otherwise user needs to click “OK” to continue). Click icon  and relevant information detected in this step will be displayed for your reference in order to solve problems. Click “Close” to close the pop-up.

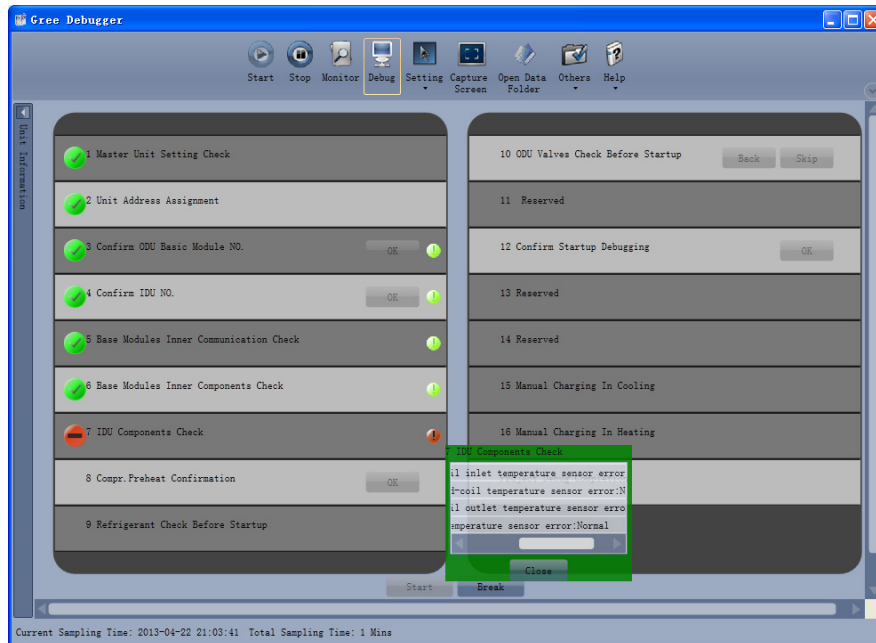

- (5) During debugging, a click on “Break” can stop debugging. Click “Start” to resume debugging and then debugging will be finished step by step. For No.10 ODU Valves Check Before Startup, there are “Back” and “Skip” buttons. If there is error in this step, you can back to step No.9 and click “OK” to restart debugging on step No.10. If the error in step No.10 is U6 error (valve error alarm), you can click “Skip”. In other cases, “Skip” button is null.
- (6) Step 11, 13 and 14 are reserved steps. And step 13, 14, 15 and 16 are steps in parallel (only one of the four will be selected according to actual needs).

3.4.4 Control units

- Click icon of “Setting” on menu bar and select parameter settings, which include “Gateway Settings”, “IDU Settings”, “System Settings”, “Project Number Conflict (In case there is project number conflict in indoor units, other functions will be shielded. Then this parameter needs to be set in order to eliminate the conflict)” and “System Historical Info”. Click the corresponding set and adjust the parameters.

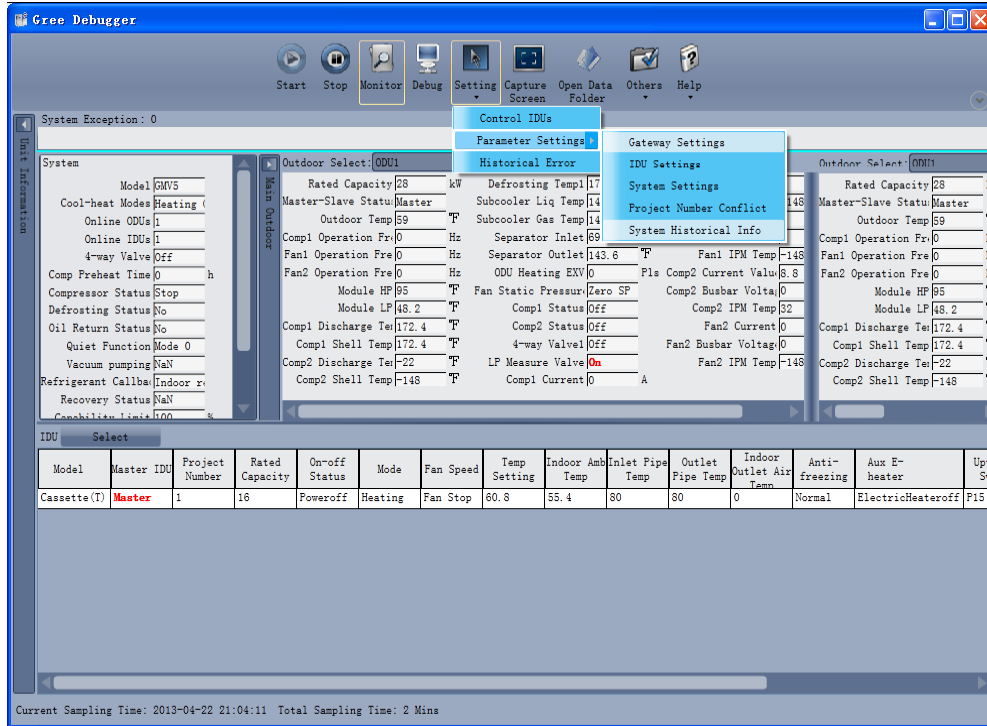

- Take indoor unit as an example. Click “IDU Settings” and a dialog box will pop up.

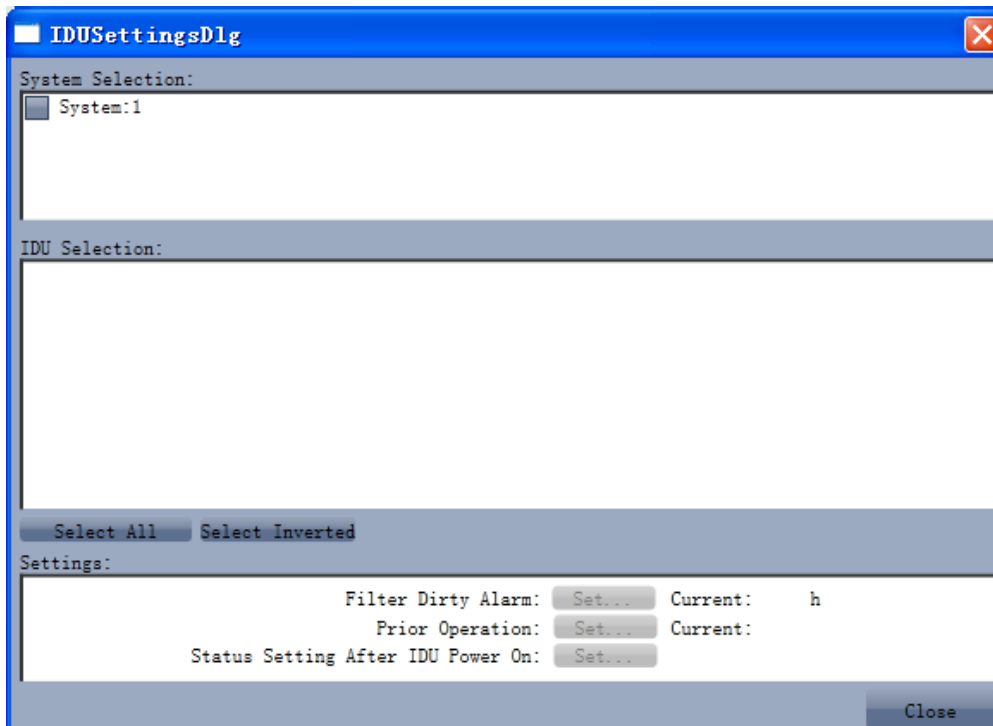

- (3) Tick the indoor units that need setting in the IDU selection zone or you may click “Select All” to select all of them or “Select Inverted” to select none of them. After selection, the current values of the corresponding parameters will be displayed in the zone of settings. Click “Set” and then click  in the pop-up dialog box to select values. Click “Set” and then the corresponding order will be sent to units. If setting is successful, it will be displayed at the current values.

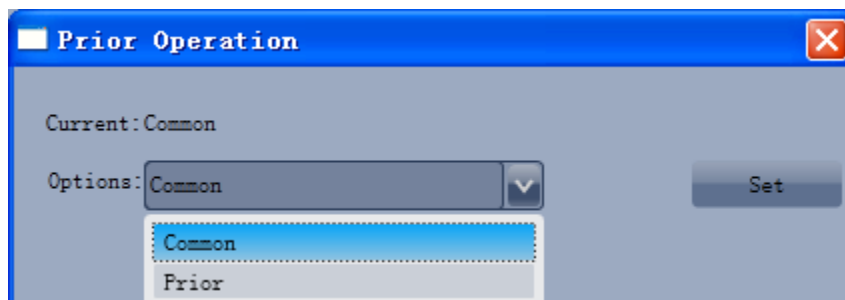
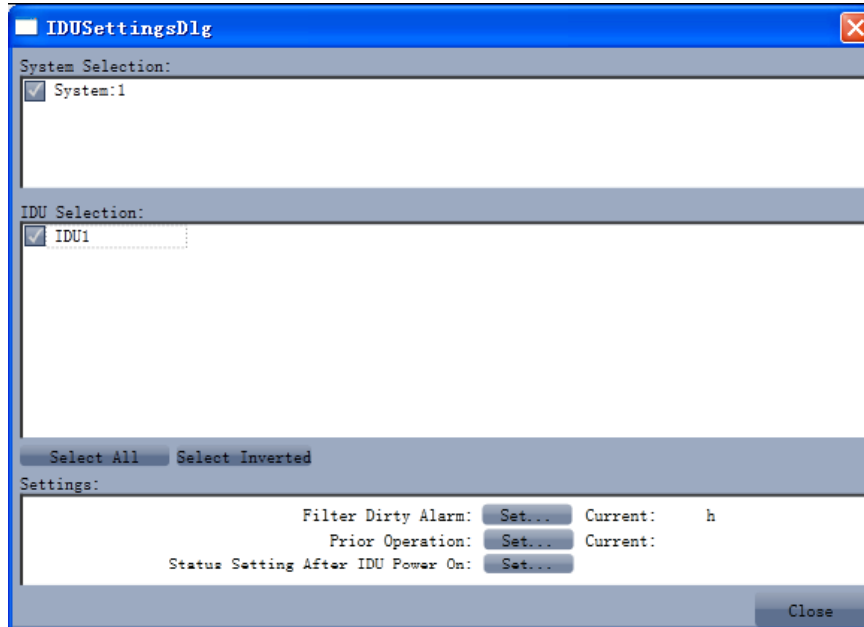

3.4.5 Other functions

(1) Capture screen

Click icon of “Capture Screen” to print the interface. If you want to open the interface, click “Open”.

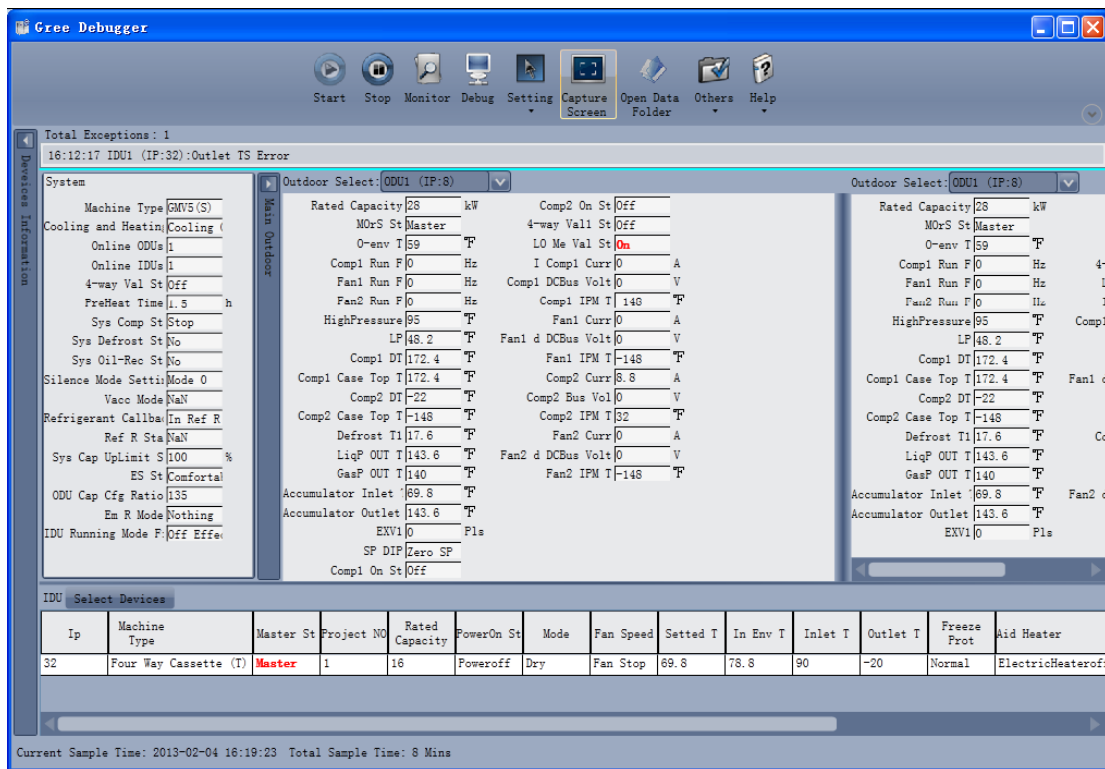
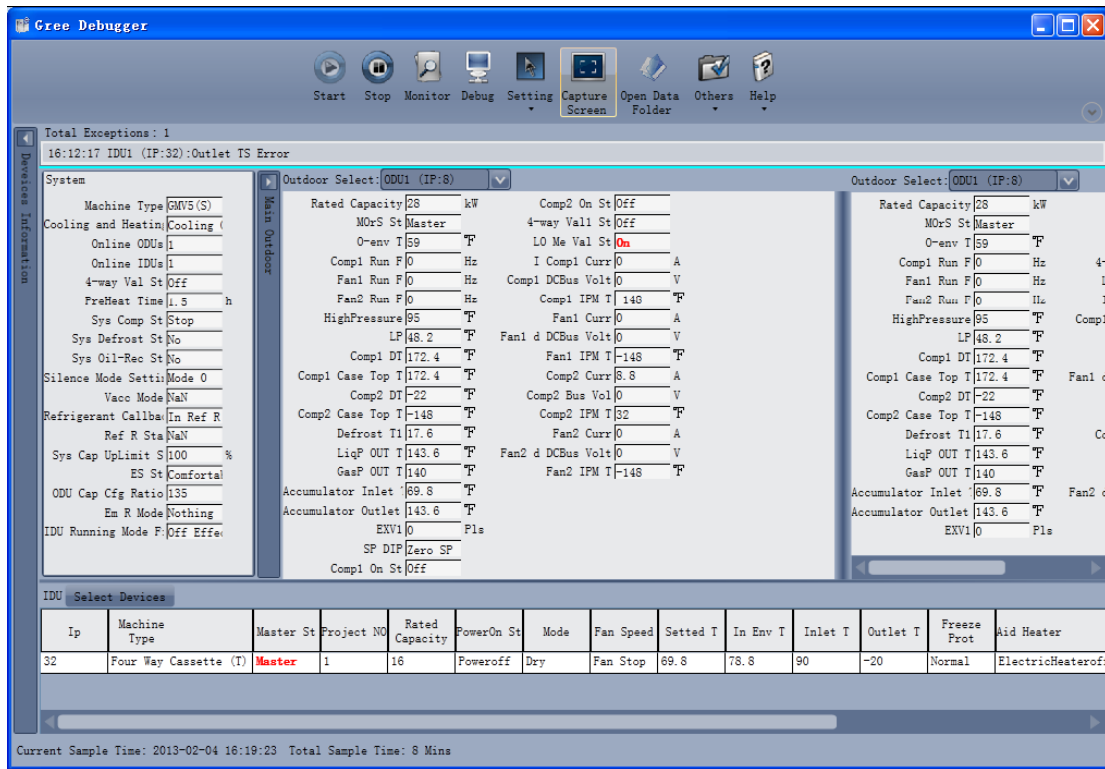

(2) Search for database folder

Click icon of “Open Data Folder” on the menu bar to open database folder.

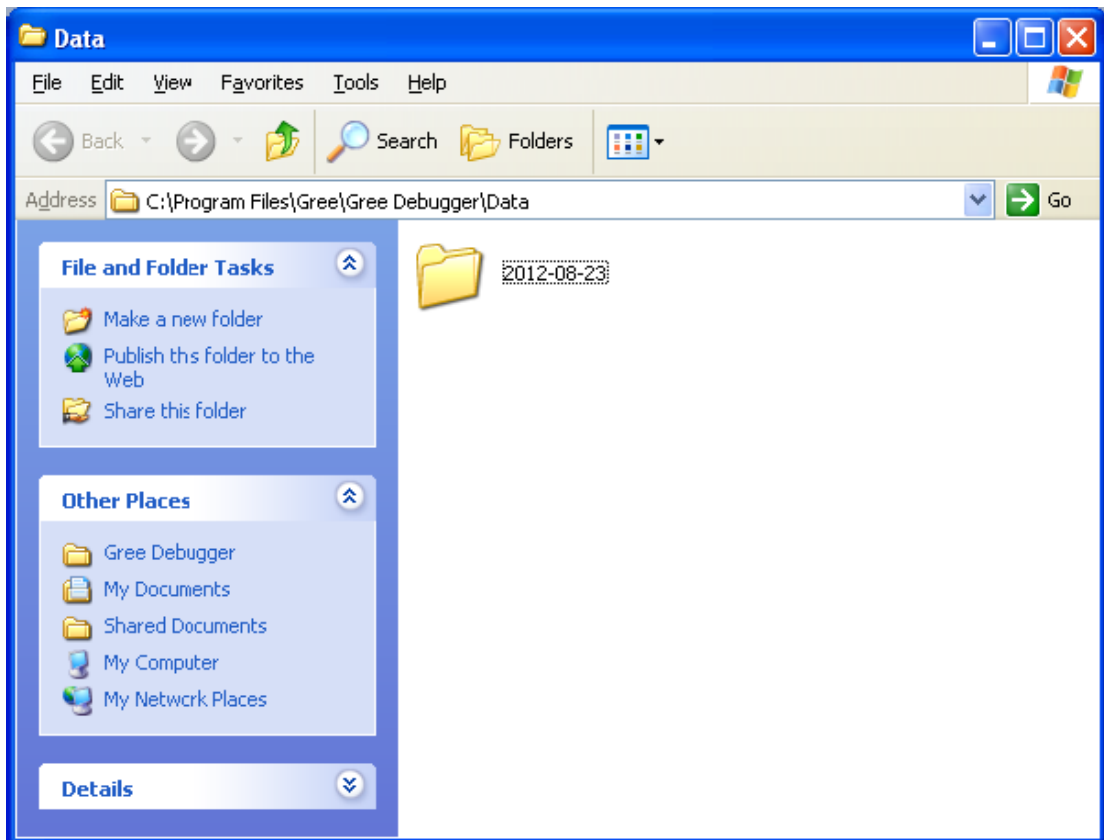
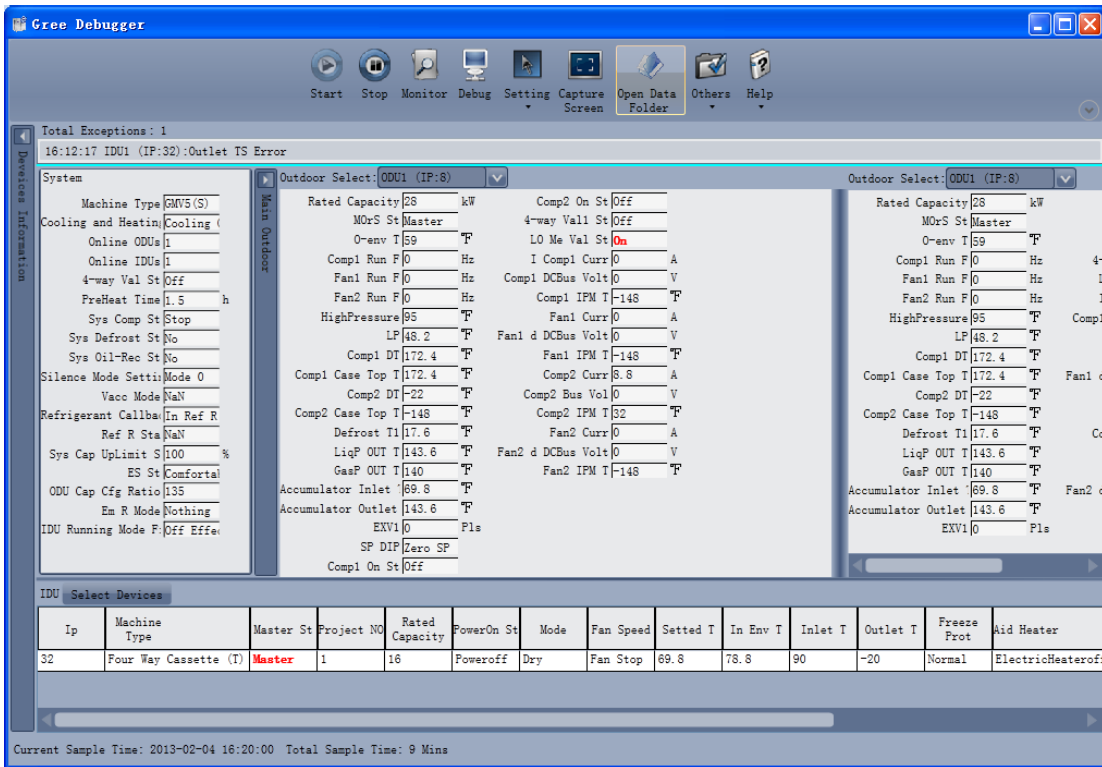

(3) Conversion of pressure value

Click icon of “Others” on the menu bar and then click “Display Settings” to select “High Low Pressure Value” and “Refrigerant Type”. Select “Temperature” and the pressure parameter displayed on the interface will be temperature. Select “Pressure” and the pressure parameter displayed on the pressure interface will be pressure. Refrigerant type will affect the pressure parameter displayed on the interface.

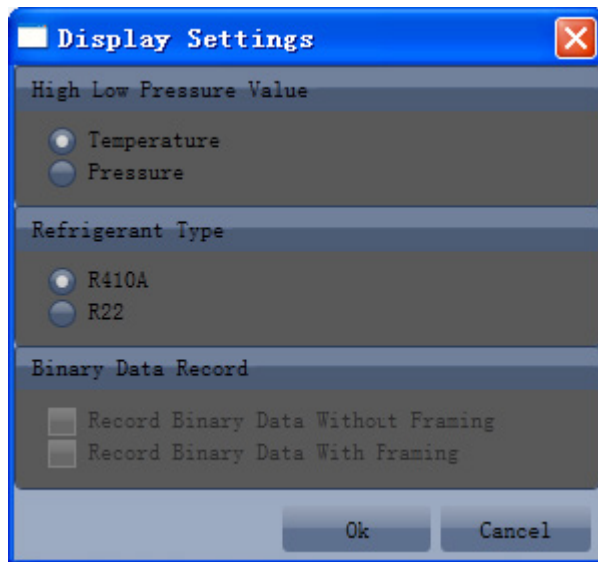
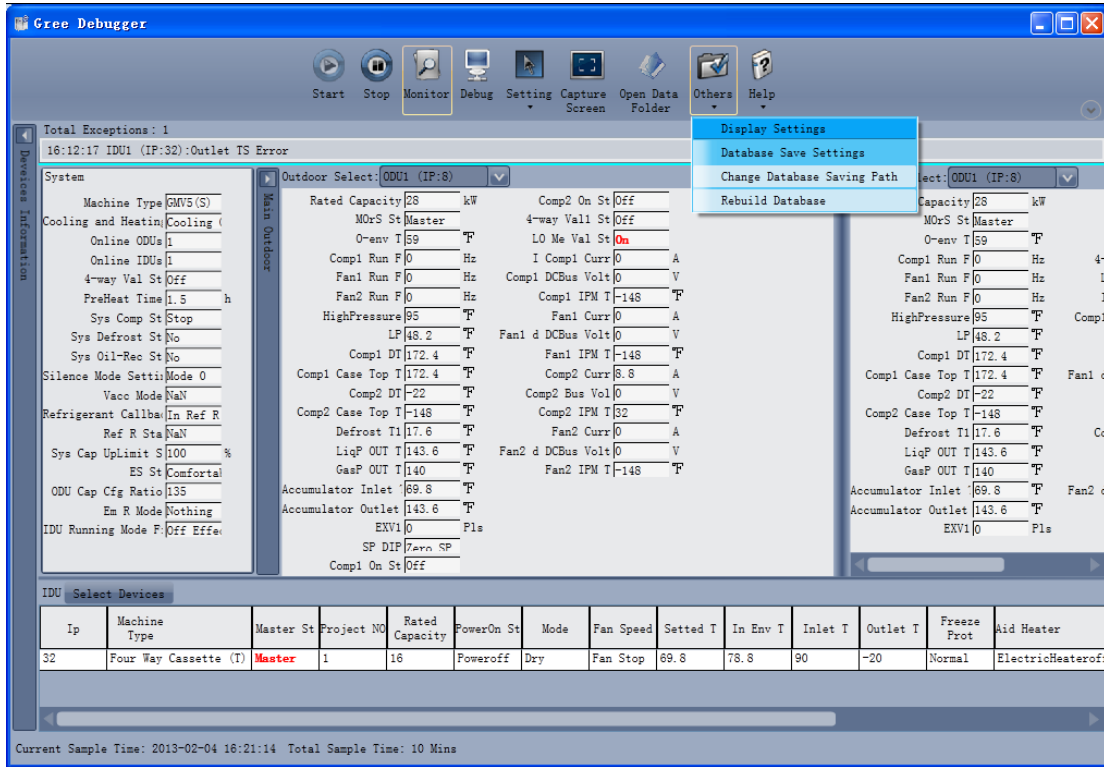

(4) Database saving of multiple systems

Click icon of “Others” on the menu bar and click “Database Save Settings” to select which system that needs to save database. Because there is a large quantity of data in a network that contains multiple systems, data of only one system can be saved.

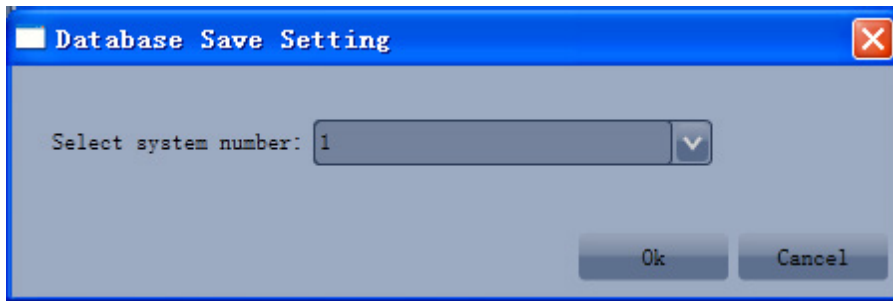
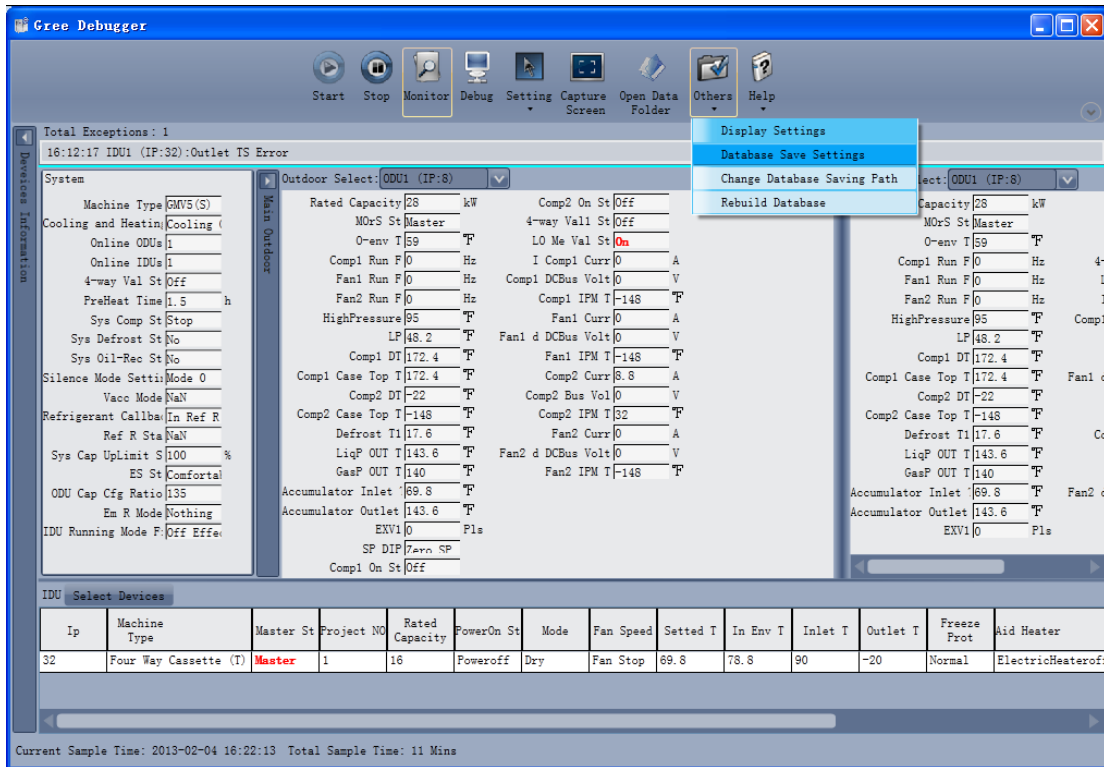

(5) Change database saving path and rebuild database

Change of database saving path and rebuilding of database should be set before the software starts monitoring (see below interface). Click “Change database saving path” and click “Browse” to change the saving path. Click “Rebuild Database” to rebuild the database folder. You can also stop monitoring and turn back to the connection interface to change saving path or rebuild database during monitoring.

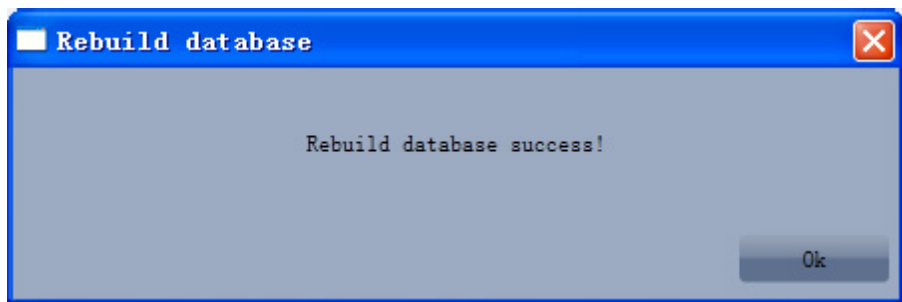
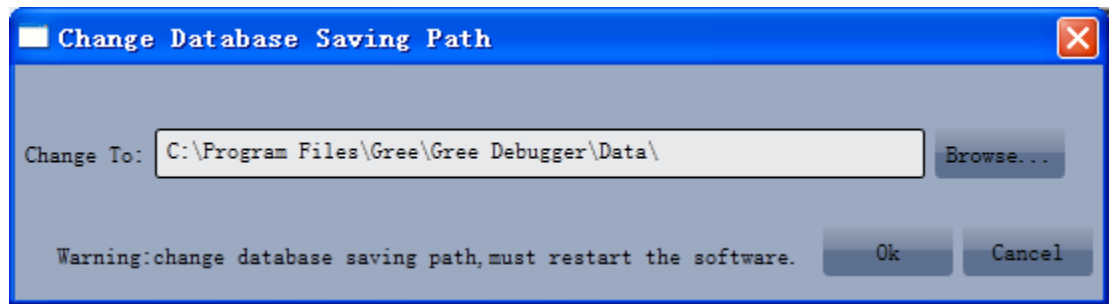
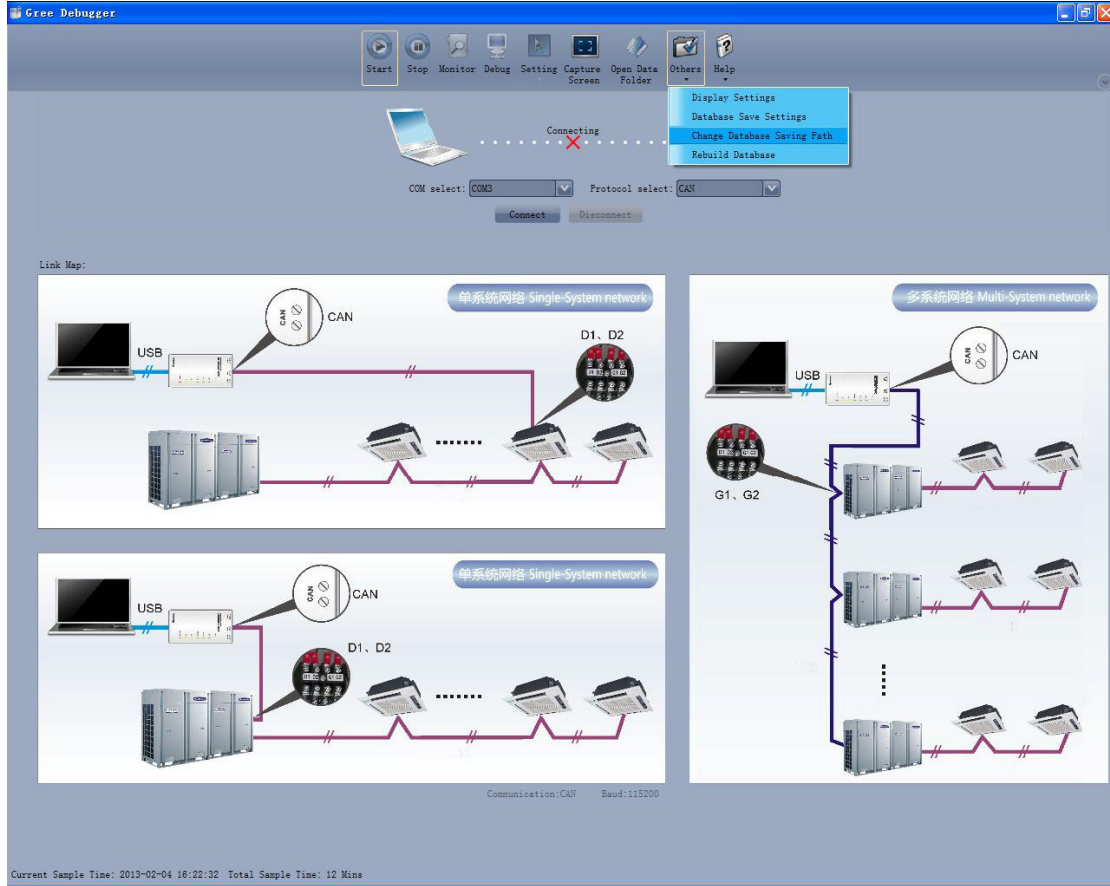

3.4.6 Usage of USB Converter

Usage of converter

- (1) Gree commissioning software should be connected with CAN interface when converter is used. For air conditioners with a single system, connect D1 and D2 interfaces of the wiring board. For air conditioners with multiple systems, connect G1 and G2 interfaces of the wiring board.

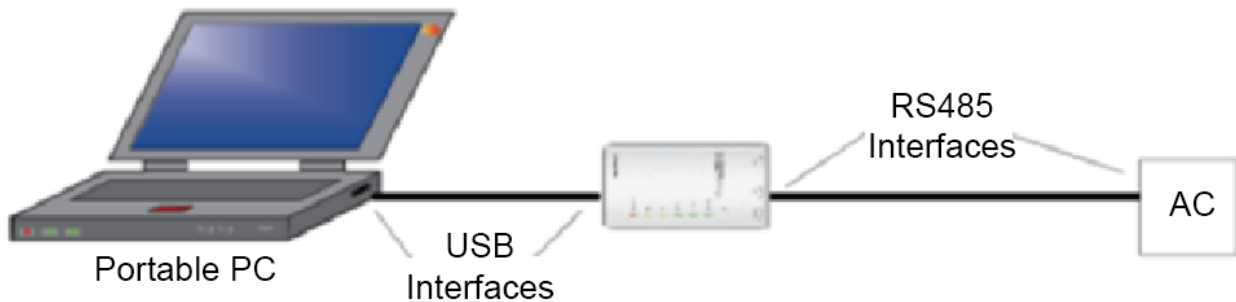

- (2) Gree monitoring software should be connected with RS485 interface when converter is used. Connect outdoor or indoor units or the mainboard of wired controller according to actual needs.

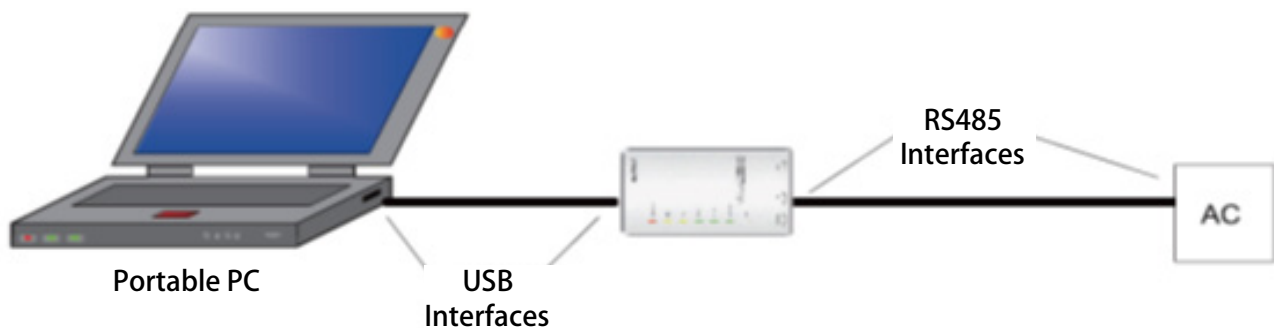

- (3) HBS, CAN and RS485 of the converter can be switched by buttons. Press the button "SET" on the converter to realize the conversion among HBS, CAN and RS485 interfaces. You can check the setting through the function LEDs.

Notice:

If it's the first time your PC uses Gree USB data converter, in order to prevent Gree USB data converter from being mistaken by your computer as other devices and make sure your mouse can work well, it is necessary to turn off the Serial Enumerator of computer after Gree USB data converter is connected.

Below are the steps:

Step 1: Right-click "My Computer" on the desktop and click "Manage".

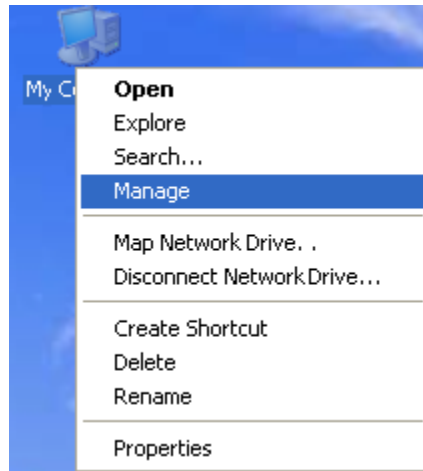

Step 2: In the pop-up window, select "Device Manager" in the left column.

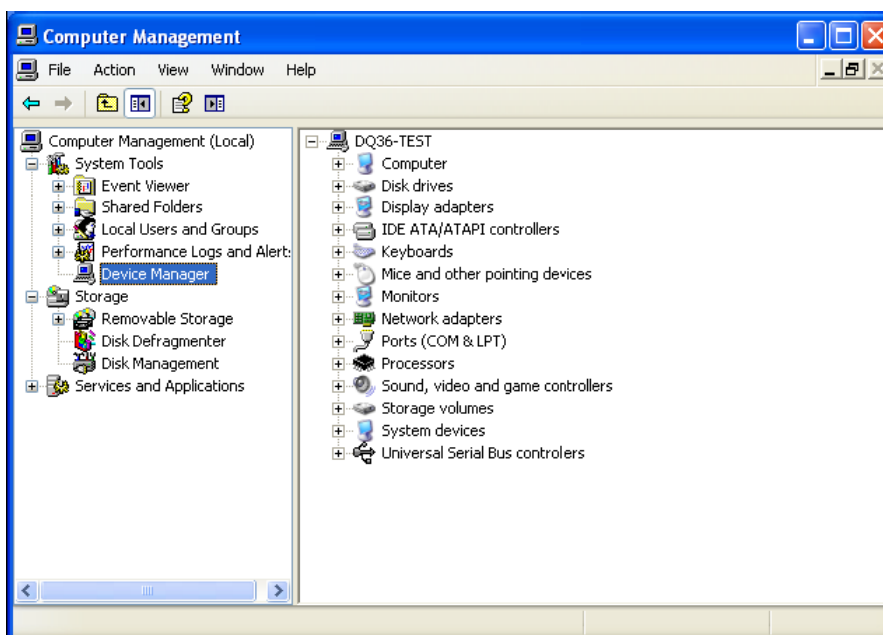

Step 3: Find "Port (COM and LPT)" in the right column. Click its |+|.

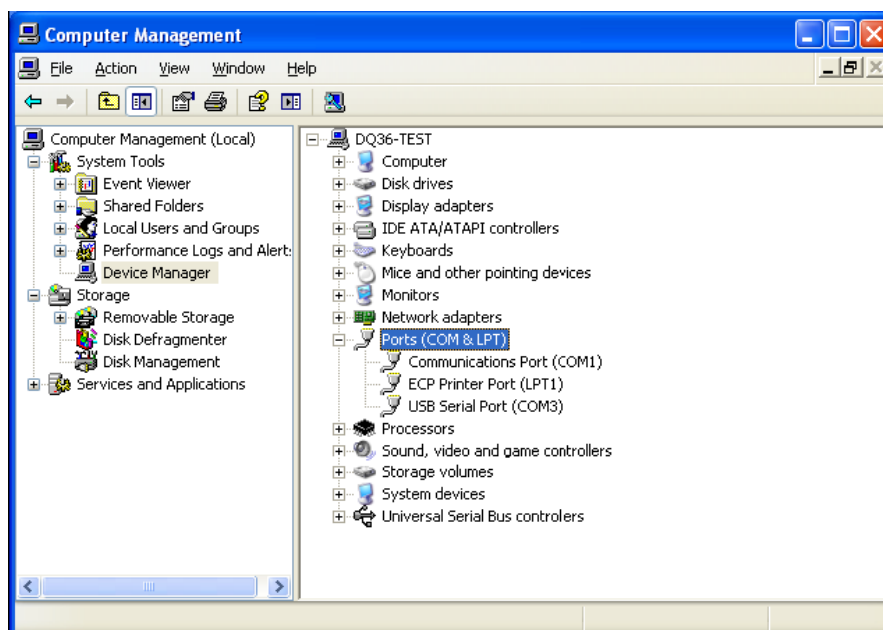

Step 4: Right-click "USB Serial Port (COM6)" and then click "Properties". The dialog box of properties will then pop up.

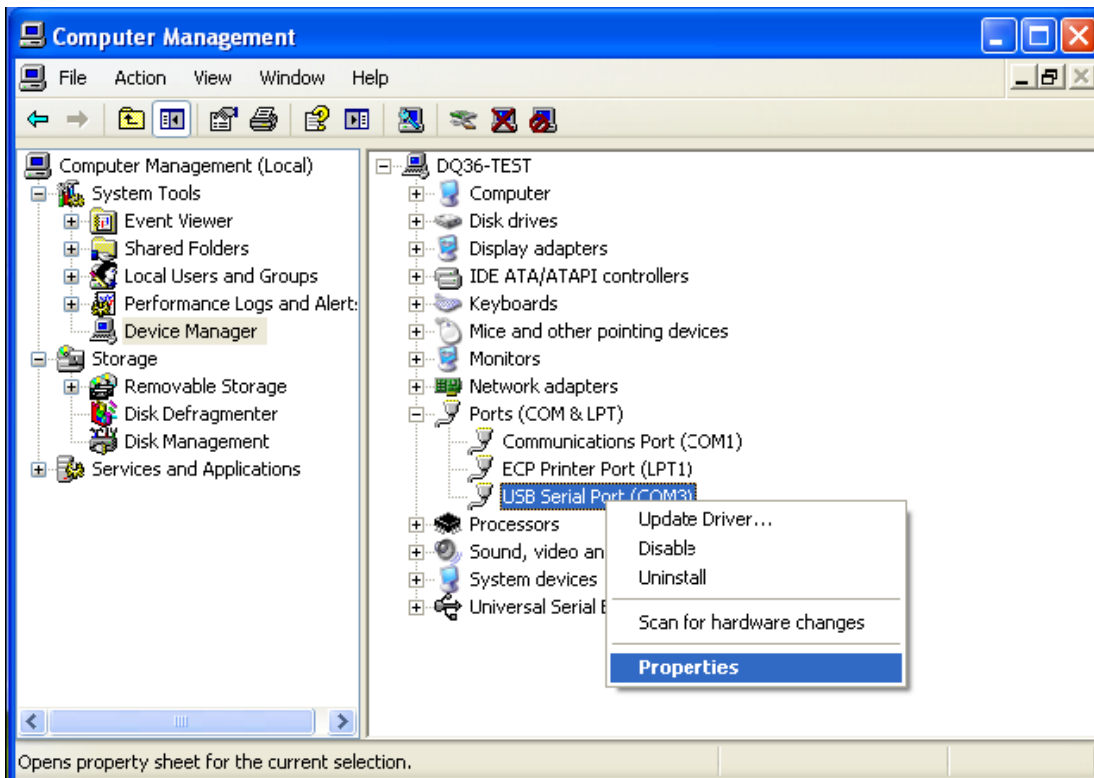

Step 5: Then click "Port Settings" in the dialog box.



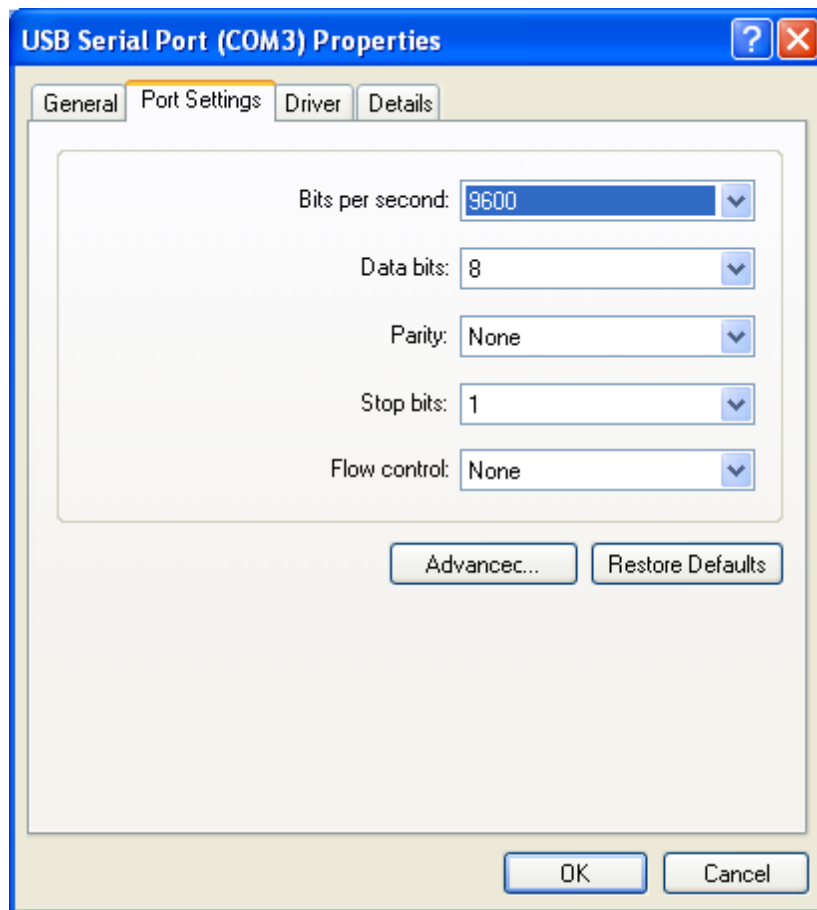

Step 6: Click "Advanced" and then a new dialog box will pop up. Find the "Serial Enumerator" in the miscellaneous options and cancel the tick. Click "OK" to exit.

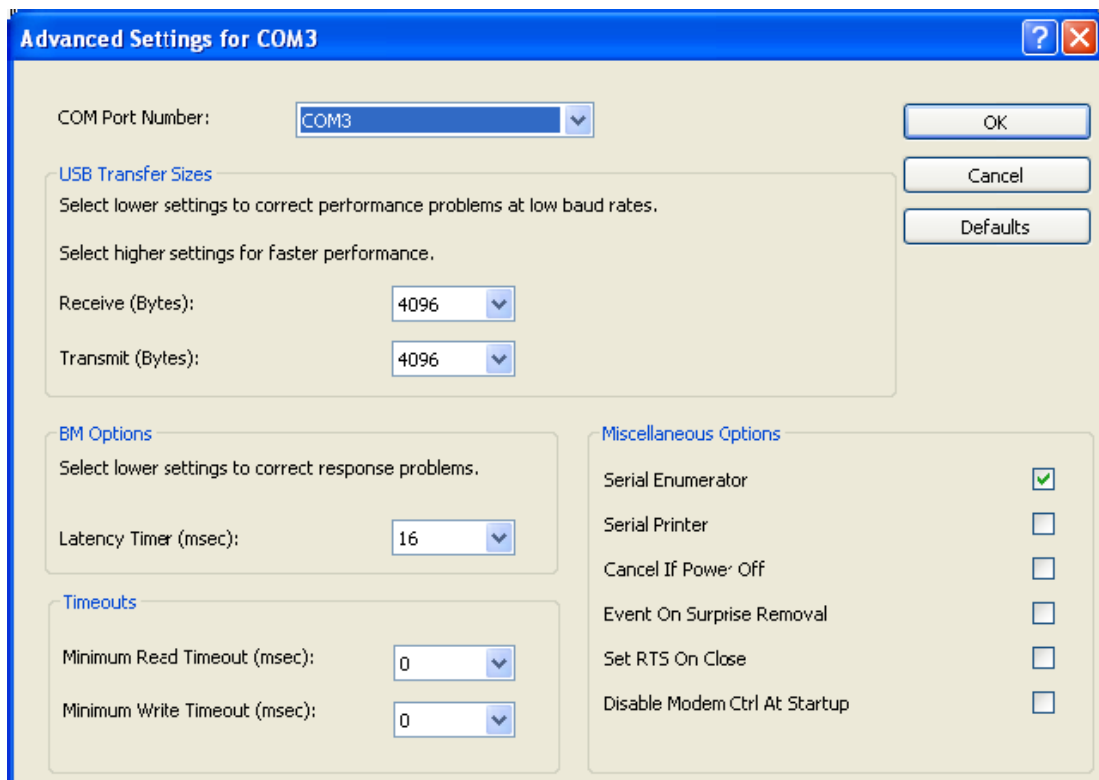

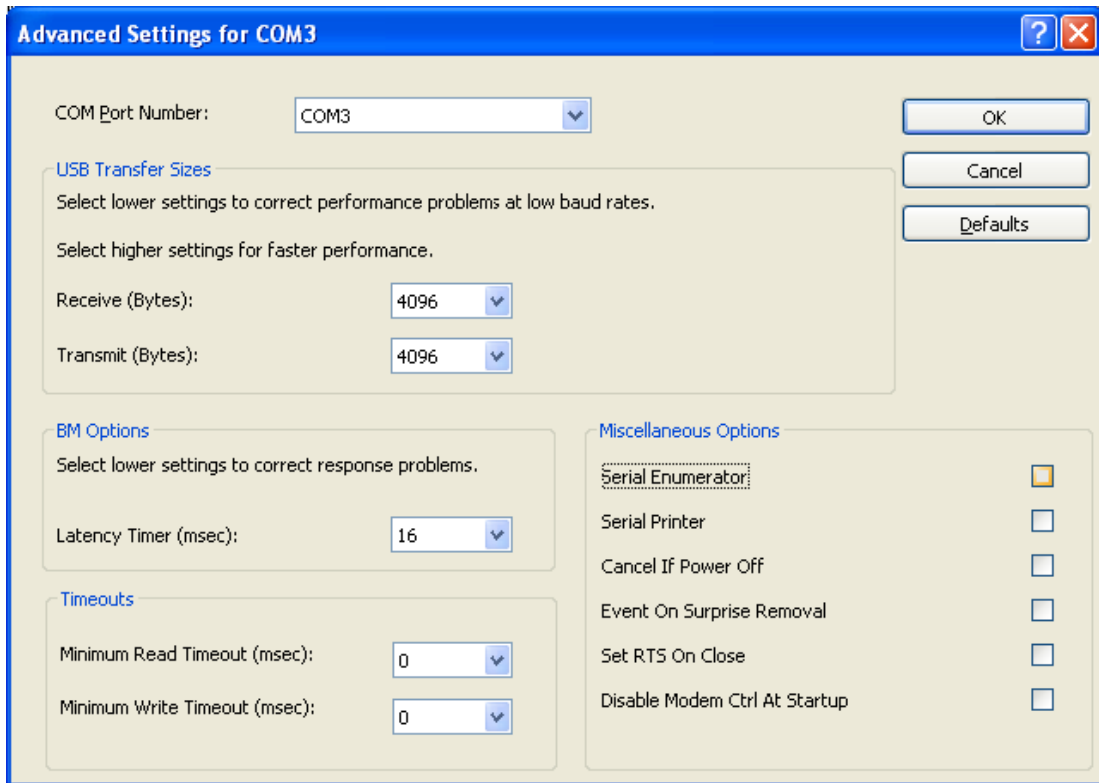

(4) Usage of converter configuring software:

- 1) When the converter is working, hold the button "SET" for 5 sec. Function LED will be flickering, indicating that the converter has enter the baud rate setting mode. Then you can use the converter configuring software to set the baud rate of converter. Baud rate supported by the converter (baud rate of air conditioner's communication interface matches with the baud rate of USB interface automatically):

Ex-factory defaulted baud rate: (unit: bps)

| AC is connected with | Baud rate of air conditioner interface | Baud rate of USB interface |
|----------------------|--|----------------------------|
| CAN | 20000/50000 self-adaptive | 115200 |
| HBS | 57600 | 38400 |
| RS485 | 9600 | 9600 |

Baud rate look-up table for RS485 interface (unit: bps)

| | | | | | | |
|-----------------|------|------|-------|-------|-------|--------|
| RS485 interface | 4800 | 9600 | 19200 | 38400 | 57600 | 115200 |
| USB interface | 4800 | 9600 | 19200 | 38400 | 57600 | 115200 |

Baud rate look-up table for HBS interface (unit: bps)

| | | | | |
|---------------|------|-------|-------|-------|
| HBS interface | 9600 | 19200 | 38400 | 57600 |
| USB interface | 4800 | 9600 | 19200 | 38400 |

Baud rate look-up table of CAN interface (unit: bps)

| | | | | |
|---------------|--------|--------|--------|--------|
| CAN interface | 20000 | 50000 | 100000 | 125000 |
| USB interface | 115200 | 115200 | 256000 | 256000 |

- 2) Double-click the desktop shortcut.



- 3) Select the needed communication serial port and language in the “System Settings”.

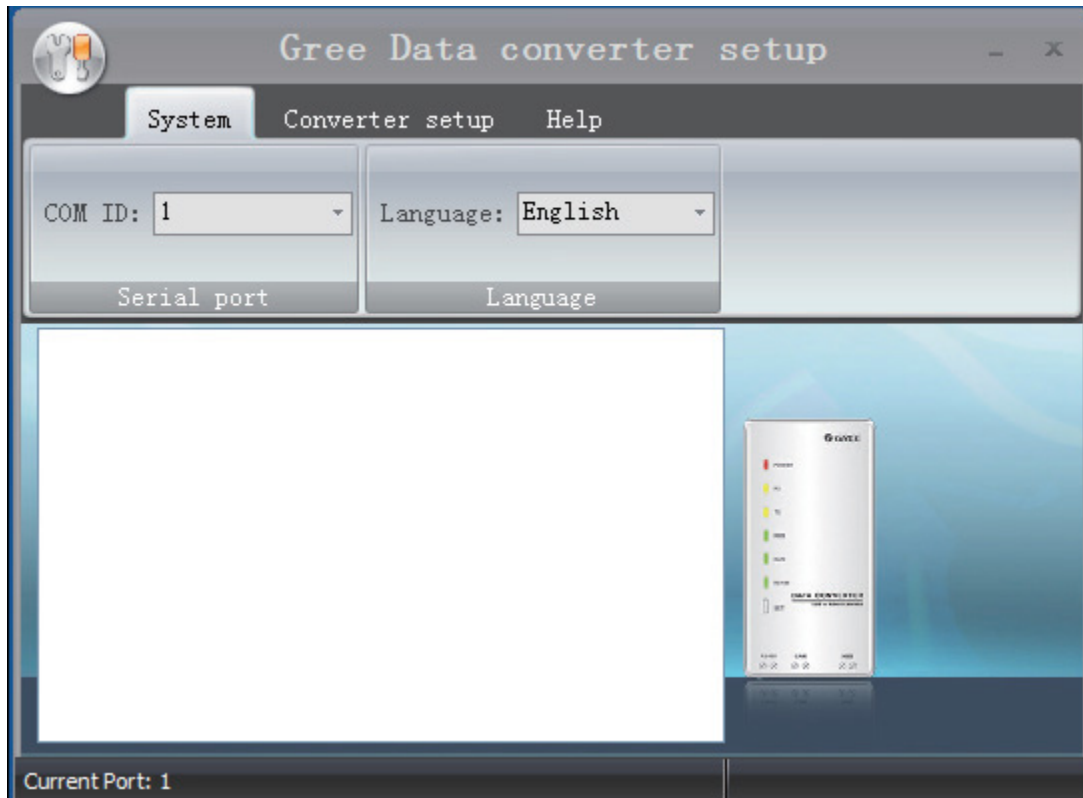

- 4) Select the function that is to be set and the corresponding baud rate (refer to the look-up table) in the “Converter Setup”. Then click “Set”.

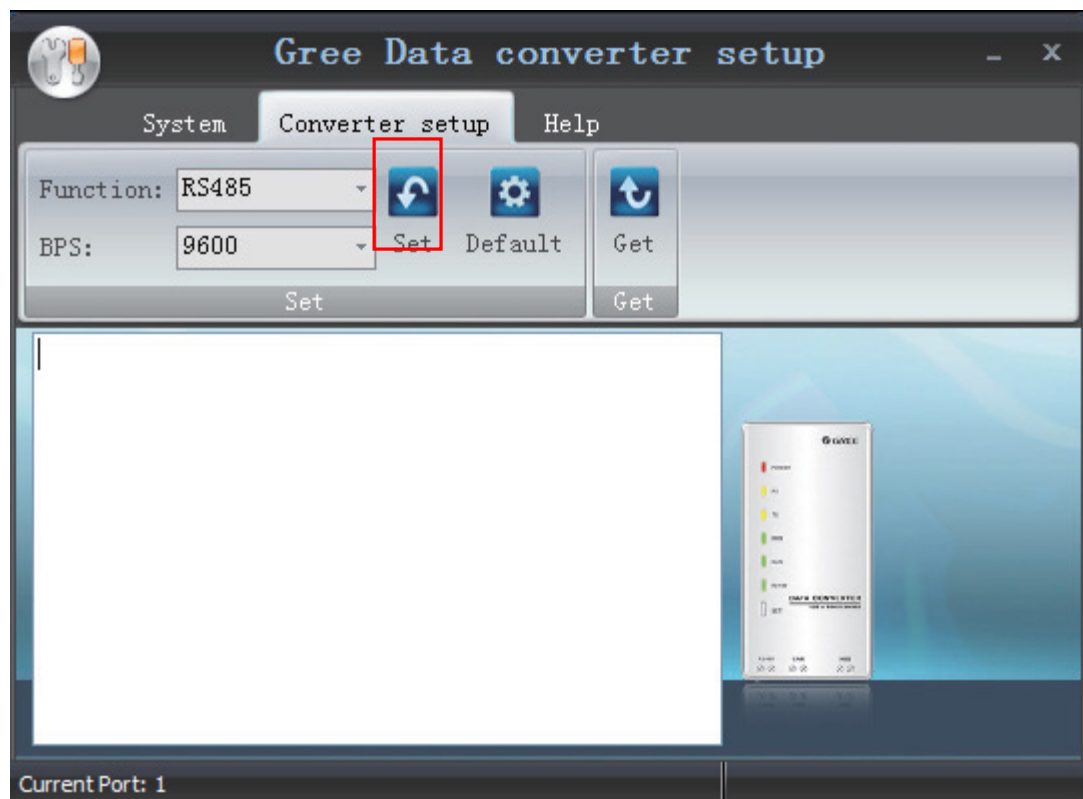

- 5) If you want to restore ex-factory settings, click “Default” to restore the default settings.

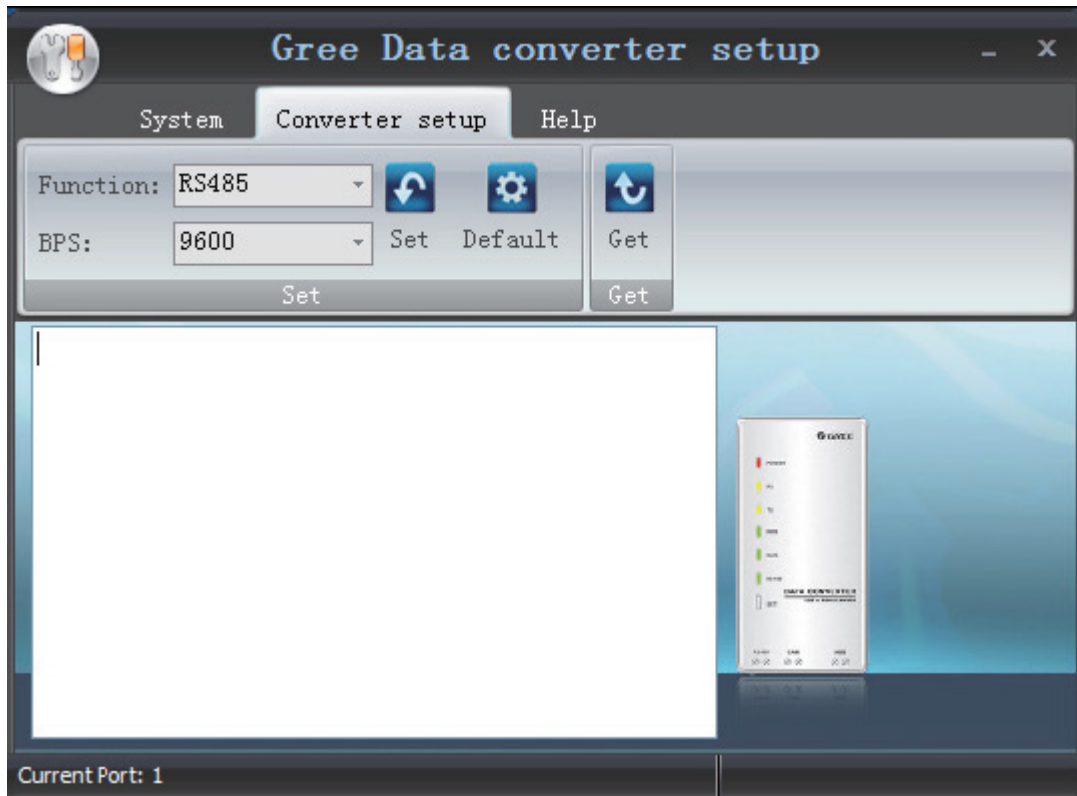

- 6) Click “Get” to get the current setting details of converter.

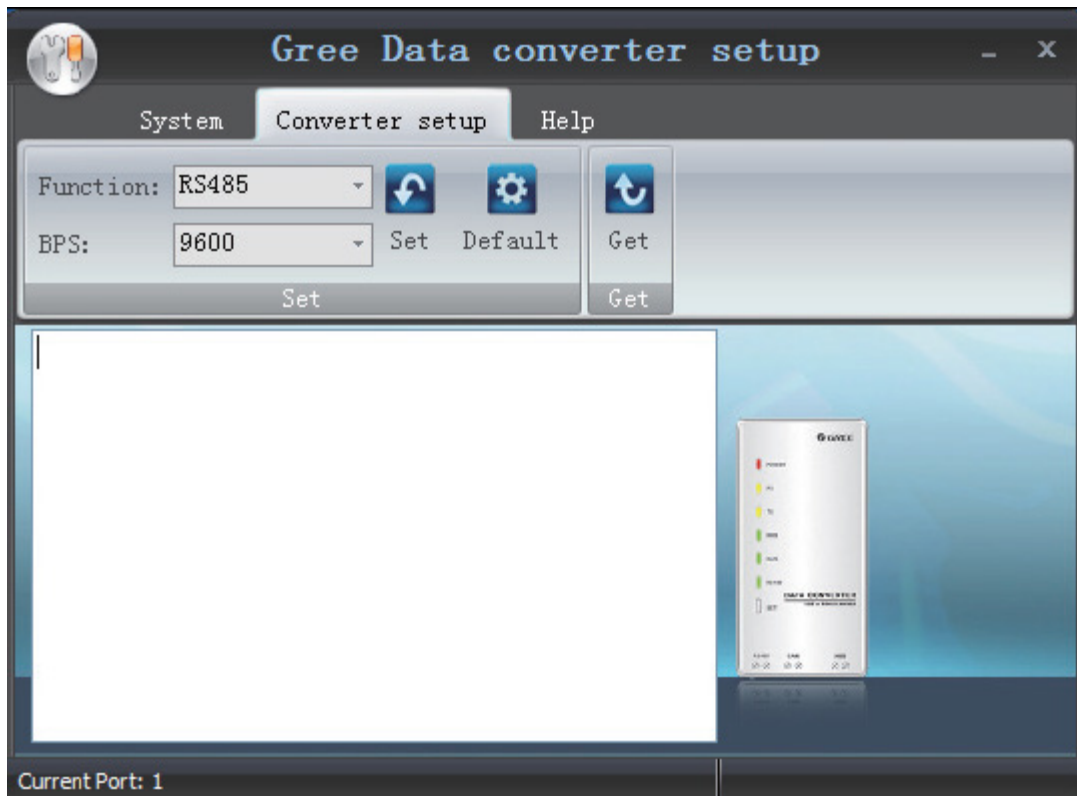

7) Switchover of Software Languages.

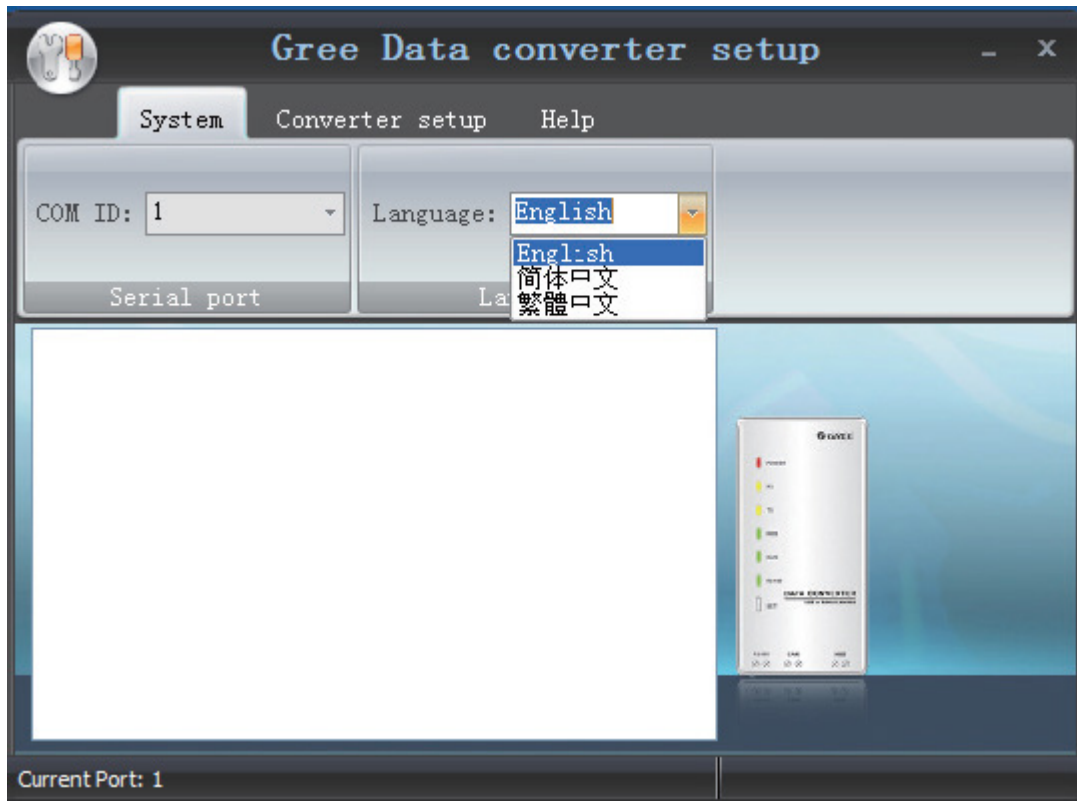

INSTALLATION

1 Engineering Installation Preparation and Notice

1.1 Installation notice

Personnel and property safety are highly concerned during the entire installation process. Installation implementation must abide by relevant national safety regulations to ensure personnel and property safety.

All personnel involved in the installation must attend safety education courses and pass corresponding safety examinations before installation. Only qualified personnel can attend the installation. Relevant personnel must be held responsible for any violation of the regulation.

1.2 Installation key points and importance

The system use refrigerant, instead of other agent, to directly evaporate to carry out the system heat. High level of pipe cleanness and dryness is required in the system. Since various pipes need to be prepared and laid out onsite, carelessness or maloperation during installation may leave impurities, water, or dust inside refrigerant pipes. If the design fails to meet the requirement, various problems may occur in the system or even lead to system breakdown.

Once the unit is energized and turned on for the first time, the display tube of outdoor unit displays "A0", which indicates debugging standby status. At this time, hold SW3 button successively for 5s on the main module to enter into the automatic debugging, and then the engineering debugging will perform according to the set procedures. Step 3 (conformation of outdoor unit' quantity) and step 4 (conformation of indoor unit' quantity) should be confirmed manually by pressing "SW3", while other procedures will be performed automatically. Once the debugging for each step is finished, "oC" will be displayed; once all engineering debugging are finished, "oF" will be displayed, which indicates the unit is under standby status.

2 Installation Materials Selection

The materials, equipment and instruments used during air conditioning engineering construction must have certifications and test reports. Products with fireproof requirements must be provided with fireproof inspection certificates and must meet national and relevant compulsory standards. If environmentally-friendly materials are to be used as required by customers, all such materials must meet national environmental protection requirement and be provided with relevant certificates.

2.1 Refrigerant piping

- (1) Material requirement: Dephosphorization drawing copper pipe for air conditioners.
- (2) Appearance requirement: The inner and outer surface of pipe should be smooth without pinhole, crack, peeling, blister, inclusion, copper powder, carbon deposition, rust, dirt or severe oxide film, and without obvious scratch, pit, spot and other defects.
- (3) Test report: Certifications and quality test reports must be provided.
- (4) The tensile strength must be at least 240 kgf/mm².
- (5) Specifications requirement.

| R410A Refrigerant System | | |
|--------------------------|---------------------|-------|
| OD (mm/inch) | Wall Thickness (mm) | Model |
| Φ6.35(1/4) | ≥0.8 | 0 |

| R410A Refrigerant System | | |
|--------------------------|---------------------|-------|
| OD (mm/inch) | Wall Thickness (mm) | Model |
| Φ9.52(3/8) | ≥0.8 | 0 |
| Φ12.70(1/2) | ≥0.8 | 0 |
| Φ15.9(5/8) | ≥1.0 | 0 |
| Φ19.05(3/4) | ≥1.0 | 0 |
| Φ22.20(7/8) | ≥1.2 | 0 |
| Φ25.40(8/8) | ≥1.2 | 0 |

- (6) After the inner part of the copper pipe is cleaned and dried, the inlet and outlet must be sealed tightly by using pipe caps, plugs or adhesive tapes.

2.2 Condensate water pipe

- (1) Pipes that can be used for air conditioner drainage include: water supplying UPVC pipe, PP-R pipe, PP-C pipe, and HDG steel pipe.
- (2) All relevant certificates and quality test reports are provided.
- (3) Requirements for specifications and wall thickness.
Water supplying UPVC pipe: Φ32mm×2mm, Φ40mm×2mm, Φ50mm×2.5mm.
HDG steel pipe: Φ25mm×3.25mm, Φ32mm×3.25mm, Φ40mm×3.5mm, Φ50mm×3.5mm.

2.3 Insulation material

- (1) Rubber foam insulation material.
- (2) Flame retardancy level: B1 or higher.
- (3) Refractoriness: at least 120°C.
- (4) The insulation thickness of condensate water pipe: at least 10 mm.
- (5) When the diameter of copper pipe is equal to or greater than Φ15.9 mm, the thickness of insulation material should be at least 20 mm; when the diameter of copper pipe is less than 15.9 mm, the thickness of insulation material should be at least 15 mm.

2.4 Communication cable and control cable

Note: For air conditioning units installed in places with strong electromagnetic interference, shielded wire must be used as the communication cables of the IDU and wired controller, and shielded twisted pairs must be used as the communication cables between IDUs and between the IDU and ODU.

Communication cable selection for ODU and IDUs:

| Material Type | Total Length L (m/feet) of Communication Cable between Indoor Unit and Indoor (Outdoor) Unit | Wire size (mm ² /AWG) | Material Standard | Remarks |
|---|--|----------------------------------|-------------------|---|
| Light/Ordinary polyvinyl chloride sheathed cord. (60227 IEC 52 /60227 IEC 53) | L≤1000m (L≤3280-5/6feet) | ≥2×0.75 (≥2×AWG18) | IEC 60227-5:2007 | 1.If the wire diameter is enlarged to 2×1 mm ² (2×AWG16), the total communication line length can reach 1500 m (4921-1/4feet). 2. The cord shall be Circular cord (the cores shall be twisted together). 3. If unit is installed in places with intense magnetic field or strong interference, it is necessary to use shielded wire. |

Communication cable selection for IDU and wired controller:

| Material type | Total length of communication line between indoor unit and wired controller L (m/feet) | Wire size (mm ² /AWG) | Material Standard | Remarks |
|---|--|----------------------------------|-------------------|---|
| Light/Ordinary polyvinyl chloride sheathed cord. (60227 IEC 52 /60227 IEC 53) | L≤250m (L≤820-1/5feet) | 2×0.75~2×1.25 (2×AWG18~2×AWG16) | IEC 60227-5:2007 | 1.Total length of communication line can't exceed 250m (820-1/5feet). 2.The cord shall be Circular cord (the cores shall be twisted together). 3.If unit is installed in places with intense magnetic field or strong interference, it is necessary to use shielded wire. |

2.5 Power cable

Only copper conductors can be used as power cables. The copper conductors must meet relevant national standard and satisfy the carrying capacity of unit.

2.6 Hanger rod and support

- (1) Hanger rod: M8 or M10.
- (2) U-steel: 14# or above.
- (3) Angle steel: 30mm×30mm×3mm or above.
- (4) Round steel: Φ10mm or above.

3 Installation of Indoor Unit

3.1 Outline and installation dimension

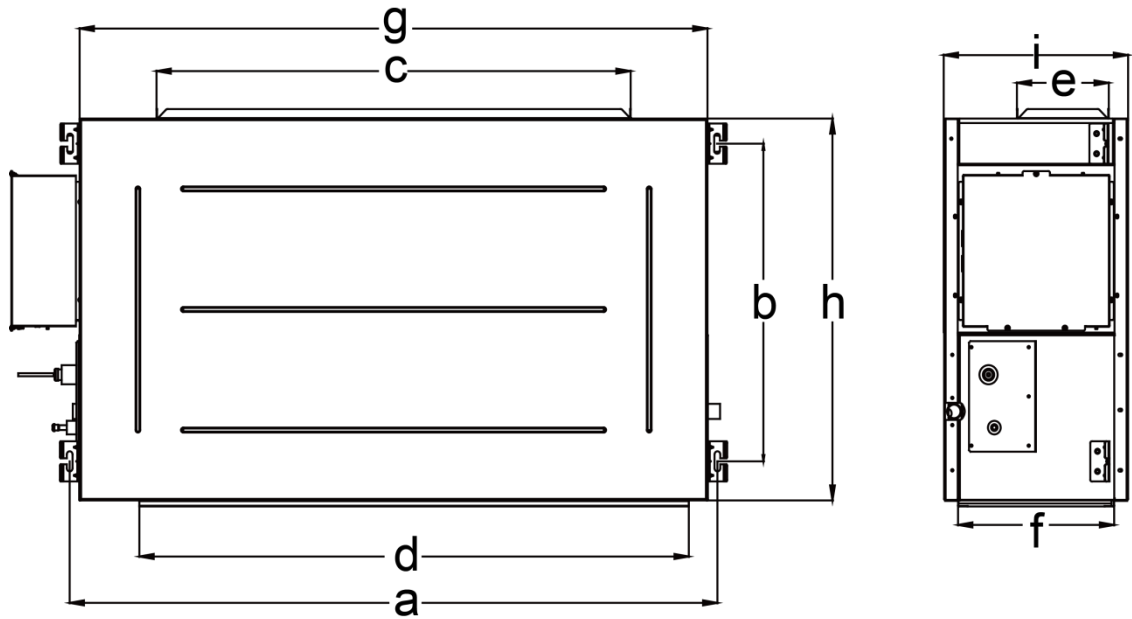

a. 20/25/30kW

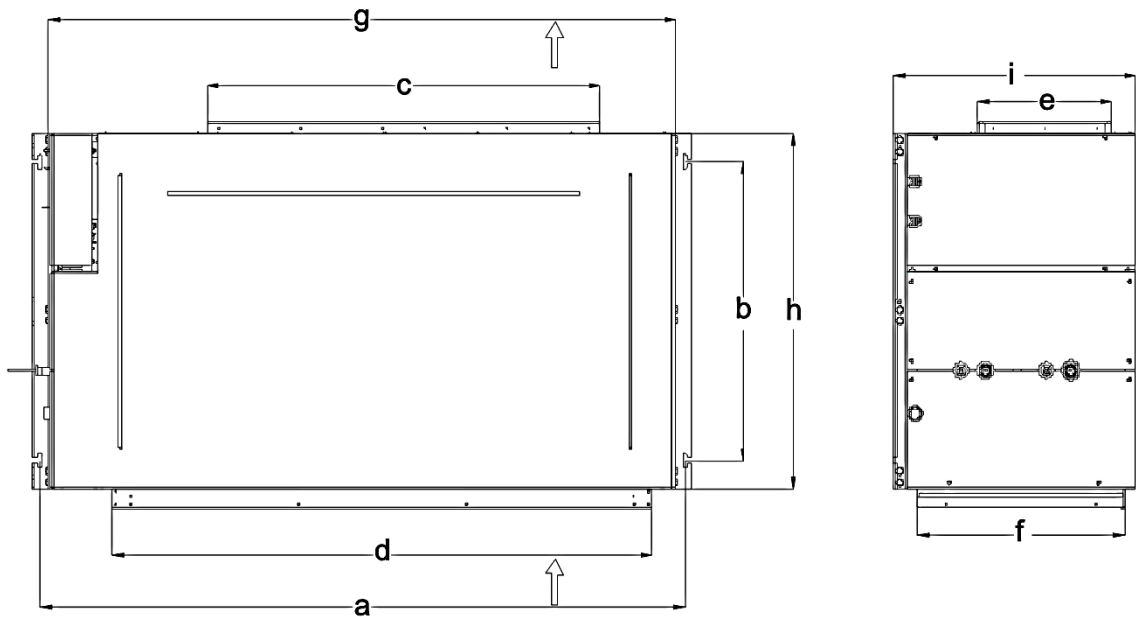

b. 40kW

Below are dimensions of a, b, c, d, e, f, g, h, i etc. for different models:

Unit: mm

| Model | a | b | c | d | e | f | g | h | i |
|---------------------|------|-----|------|------|-----|-----|------|-----|-----|
| FGR20Pd/DNa-X(I) | 1355 | 632 | 992 | 1150 | 192 | 326 | 1315 | 760 | 385 |
| FGR25Pd/DNa-X(I) | 1563 | 707 | 992 | 1350 | 192 | 402 | 1520 | 840 | 450 |
| FGR30Pd/DNa-X(I) | 1563 | 707 | 962 | 1350 | 262 | 402 | 1520 | 840 | 450 |
| FGR40Pd/D(2)Na-X(I) | 1730 | 760 | 1054 | 1450 | 359 | 557 | 1680 | 900 | 650 |

3.2 Installation space

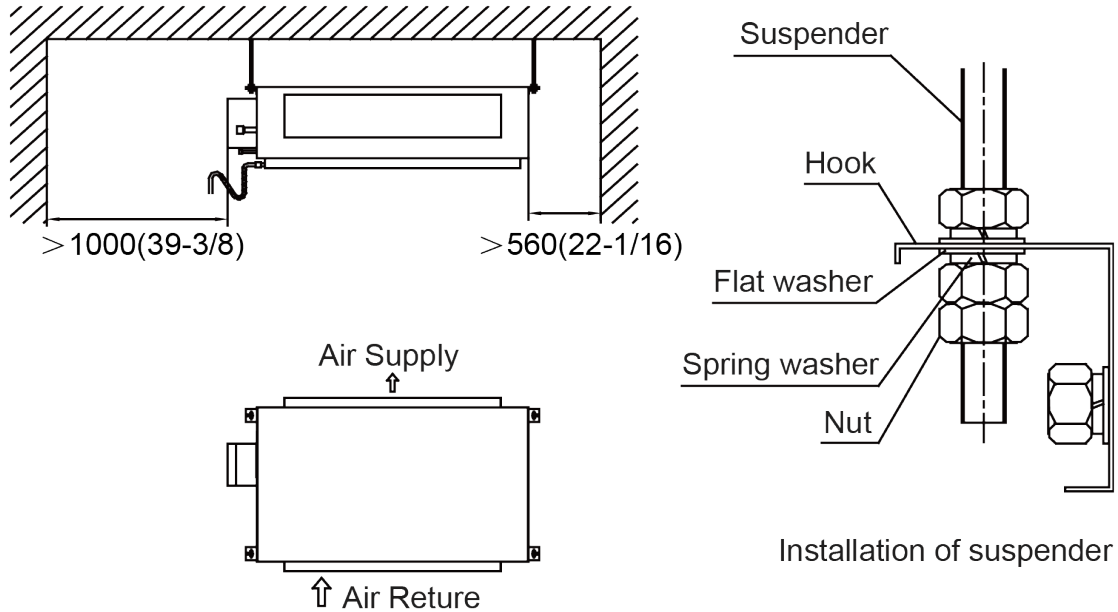

3.3 External static pressure setting and reading

3.3.1 External static pressure setting

You can enter P67 select the way of adjusting static pressure for the blast pipe manually or automatically. The default value is 00, which means adjusting manually.

- (1) If you choose 00, you can select the suitable level for any blast pipes. It can reach to 250Pa. You can enter P30 to set the value.
 - 1) Long press FUNCTION button for 5s and the temperature zone displays "C00"; long press FUNCTION button for another 5s to enter the interface of setting wired controller parameters. "P00" is displayed in temperature zone.
 - 2) Press "▲" or "▼" button to select parameter code. Press MODE button to enter parameter setting. At that time, parameter value is blinking. Press "▲" or "▼" button to adjust the parameter value and press ENTER/CANCEL button to finish setting.
 - 3) Press ENTER/CANCEL button to return to last step until exists setting parameters.

The parameter setting list is as following:

| Parameter code | Parameter name | Parameter range | Default value | Note |
|----------------|---|--|---------------|---|
| P30 | Set static pressure of indoor fan motor | 01-09: static pressure level of indoor fan motor | 05 | There are 9 static pressure level: 01, 02, 03, 04, 05, 06, 07, 08, 09 |

Note:

- ① Under parameter setting status, FAN, TIMER, SLEEP and SWING button are invalid. Press.
- ② ON/OFF button to go back to home page, but not turning on/off the unit.
- ③ If the power cord is more than 15 m (49-1/4 ft.) long, please increase properly the sectional area of power cord to avoid overload, which may cause accident.

| External Static Pressure | static pressure level of indoor fan motor |
|--------------------------|---|
| 0 inWG(0 Pa) | 01 |
| 0.12 inWG(30 Pa) | 02 |
| 0.24 inWG(60 Pa) | 03 |
| 0.36 inWG(90 Pa) | 04 |
| 0.48 inWG(120 Pa) | 05 |
| 0.60 inWG(150 Pa) | 06 |
| 0.72 inWG(180 Pa) | 07 |
| 0.84 inWG(210 Pa) | 08 |
| 1.00 inWG(250 Pa) | 09 |

Note: Keep in mind that a shortage of airflow quantity or water leakage will result because the air conditioner will be operated outside the rated range of airflow quantity if the external static pressure is wrongly set.

- (1) If you choose 01, the indoor motor will adjust static pressure of the blast pipe automatically when start-up every time. Here is the way to enter P67.
- (2) Long press FUNCTION button for 5s and the temperature zone displays "C00"; press MODE button for three times in 3s; long press FUNCTION button for another 5s to enter the interface of setting wired controller parameters. "P00" is displayed in temperature zone.
- (3) Press "▲" or "▼" button to select parameter code. Press MODE button to enter parameter setting. At that time, parameter value is blinking. Press "▲" or "▼" button to adjust the parameter value and press ENTER/CANCEL button to finish setting.
- (4) Press ENTER/CANCEL button to return to last step until exists setting parameters.

The parameter setting list is as following:

| Parameter code | Parameter name | Parameter range | Default value |
|----------------|---|-----------------------------------|---------------|
| P67 | Select the way of adjusting static pressure | 00: manually 01: automatically | 00 |

3.3.3 External static pressure reading

If you want to know the exact external static pressure, you can set P67 to 01, restart the machine, after about 2 minutes, enter C24 to read the exact ESP.

- (1) Long press FUNCTION button for 5s and the temperature zone displays "C00"; press MODE button for three times in 3s.
- (2) Press "▲" or "▼" button to C24, there you can read the exact ESP.

3.4 Installation notice

- (1) The unit shall be installed by the professional personnel according to this installation instruction

to ensure proper use.

- (2) Please contact the local Gree appointed service center before installation. Any malfunction caused by the unit that is not installed by the Gree appointed service center would probably not be dealt with on time because of the inconvenience of the business contact.
- (3) It should be guided under the professional personnel when the air conditioner unit is moved to other place.

3.5 Selection of air switch and power cord

| Model | Power supply | Circuit breaker capacity (A) | Number of ground wire * Min sectional area (mm ²) | Number of power cord * Min sectional area (mm ²) |
|---------------------|---------------------|--------------------------------|---|--|
| FGR20Pd/DNa-X(I) | 220V~50/60Hz | 10 | 1×1.5 | 2×1.5 |
| FGR20Pd/DNa-X(O) | 380-415V 3N~50/60Hz | 20 | 1×2.5 | 4×2.5 |
| FGR25Pd/DNa-X(I) | 220V~50/60Hz | 10 | 1×1.5 | 2×1.5 |
| FGR25Pd/DNa-X(O) | 380-415V 3N~50/60Hz | 25 | 1×2.5 | 4×2.5 |
| FGR30Pd/DNa-X(I) | 220V~50/60Hz | 10 | 1×1.5 | 2×1.5 |
| FGR30Pd/DNa-X(O) | 380-415V 3N~50/60Hz | 32 | 1×4.0 | 4×4.0 |
| FGR40Pd/D(2)Na-X(I) | 3N~ 380V 50/60Hz | 10 | 1×1.5 | 4×1.5 |

4 Installation of outdoor unit

4.1 Check before installation

- (1) Before installation, please check the power cord if it complies with the power supply requirement on the nameplate. Make sure the power supply is safe.
- (2) This air conditioner must be properly grounded through the receptacle to avoid electric shock. The ground wire shouldn't be connected with gas pipe, water pipe, lightning arrester or telephone line.
- (3) Maintain good air circulation to avoid lacking oxygen.
- (4) Read this manual carefully before installation.

4.2 Selection of installation site

- (1) Select a location which is strong enough to hold unit's weight so that unit can stand still and erect.
- (2) Make sure the unit is not exposed to sun and rain. And the location can resist dust, typhoon and earthquake.
- (3) Please keep the unit away from inflammable, explosive and corrosive gas or waste gas.
- (4) Make sure the location has space for heat exchange and maintenance so that unit can operate reliably with good ventilation.
- (5) ODU and IDU should stay as close as possible to shorten the length of refrigerant pipe and reduce bend angles.
- (6) Select a location which is out of children's reach. Keep the unit away from children.

4.3 Carrying and installing outdoor unit

When carrying the outdoor unit, hang the unit in four directions with two sufficient ropes. In order to

avoid excursion from the center, the angel of rope must be smaller than 40° during hanging and moving.

4.4 Installation notices

In order to ensure proper operation, the selection of installation site must conform to the following principle:

- (1) The discharged air of outdoor unit will not flow back and there is sufficient space around the unit for maintenance;
- (2) The installation site must be well ventilated to ensure sufficient air intake and discharge. Make sure there is no obstacle at the air inlet and air outlet. If there is any obstacle, please remove it;
- (3) The installation site shall be able to withstand the weight of outdoor unit and capable for soundproof and vibration. The air outlet and noise of unit will not affect neighbors;
- (4) The hanging of outdoor unit must use appointed hanging hole. Pay attention to protect the unit during hanging and installation. Prohibit hitting the sheet metal to avoid rust in the future;
- (5) Avoid direct sunlight;
- (6) The rain and condensation water can be drained out smoothly;
- (7) The outdoor unit will not be embedded by the snow and not affected by garbage and oil smog;
- (8) The installation of outdoor unit shall adopt rubber damping pad or spring damper to reduce noise and vibration;
- (9) The installation dimension shall accord with the installation requirement of this manual and the outdoor unit must be fixed at the installation site;
- (10) The installation shall be done by professional technicians;
- (11) For the FGR40Pd/D(2)Na-X, there are two outdoor units, Module 1 is the master controller. It must be installed like this:

- 1) The diagram of connection pipe and Master control setting.

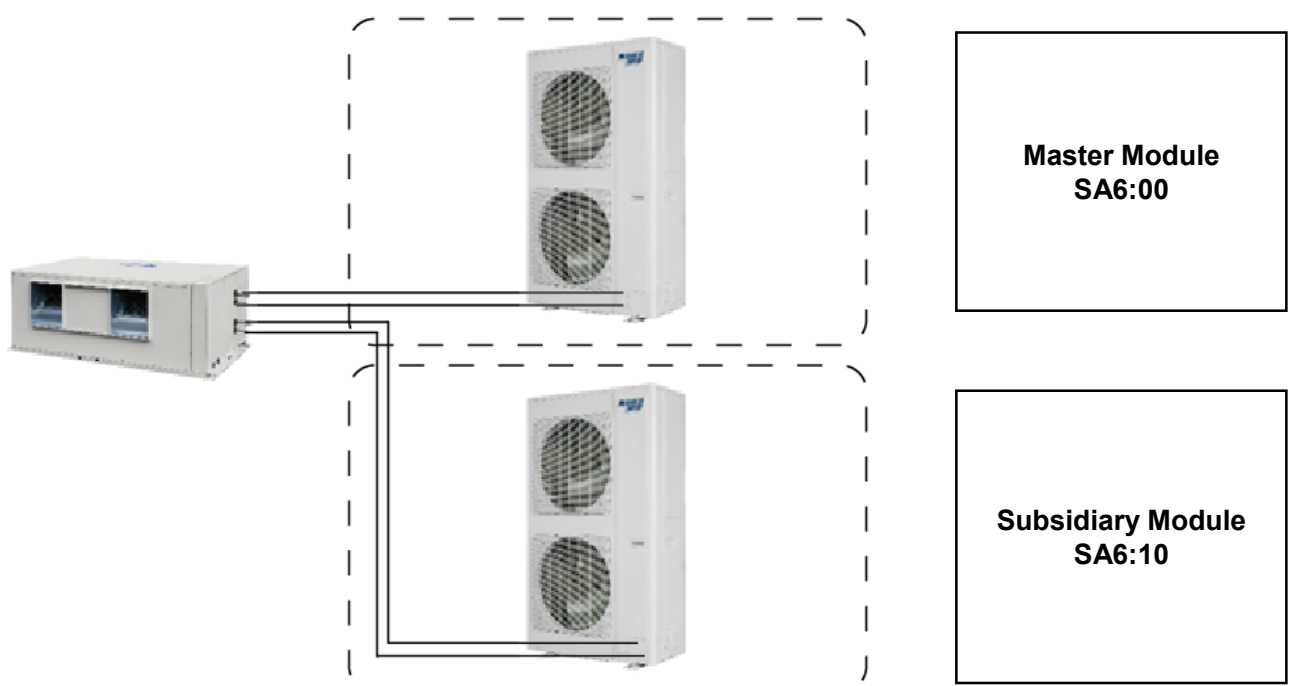

2) The connection method of communication wires.

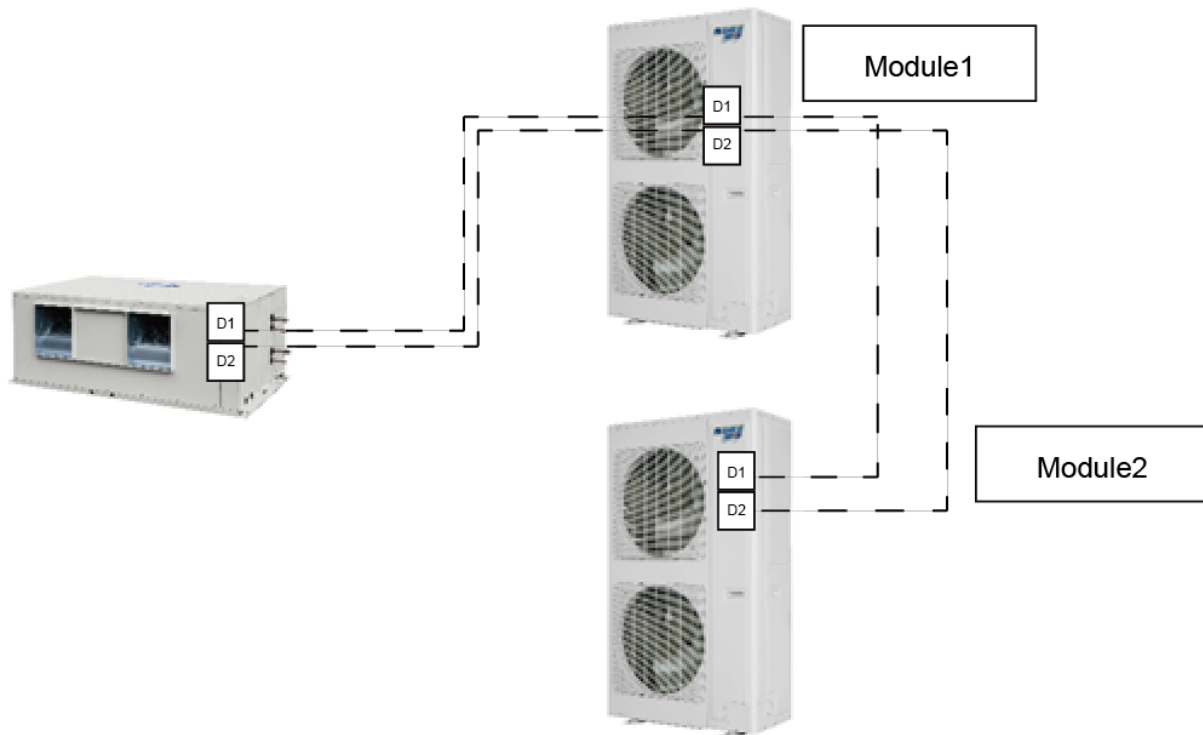

4.5 Fixing and damping of unit

The outdoor unit shall be fixed with 4 M12 bolts and closely contacted with the foundation. Otherwise, big vibration and noise will be caused.

The outdoor unit shall be fixed firmly. The rubber board with thickness over 20mm or corrugated rubber damping pad shall be applied between the unit and foundation.

4.6 Outline dimension and position of installation hole

When carrying the outdoor unit, hang the unit in four directions with two sufficient ropes. In order to avoid excursion from the center, the angel of ropes must be smaller than 40° during hanging and moving.

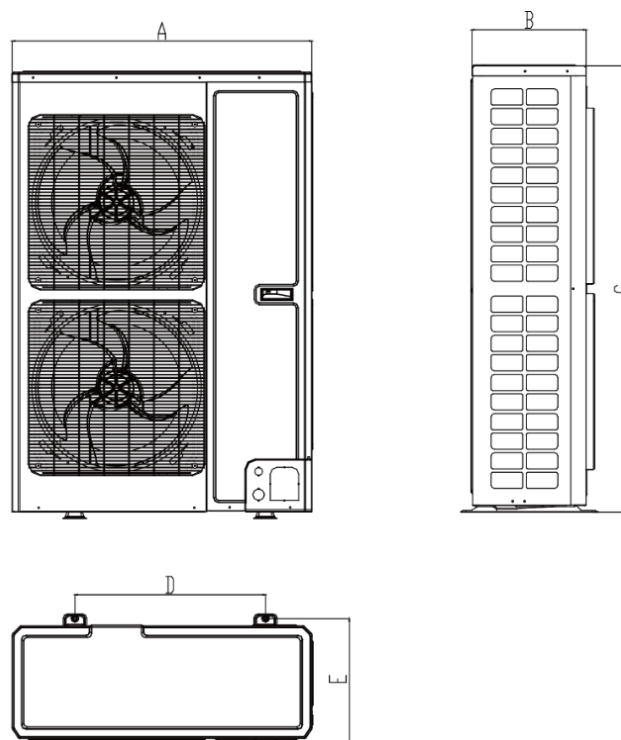

Unit: mm

| Model | A | B | C | D | E |
|------------------|-----|-----|------|-----|-----|
| FGR20Pd/DNa-X(O) | 940 | 320 | 1430 | 632 | 350 |
| FGR25Pd/DNa-X(O) | 940 | 460 | 1615 | 610 | 486 |
| FGR30Pd/DNa-X(O) | 940 | 460 | 1615 | 610 | 486 |

4.7 Installation space requirement

If all sides of the ODU (including the top) are surrounded by walls, process according to the following requirements for installation space:

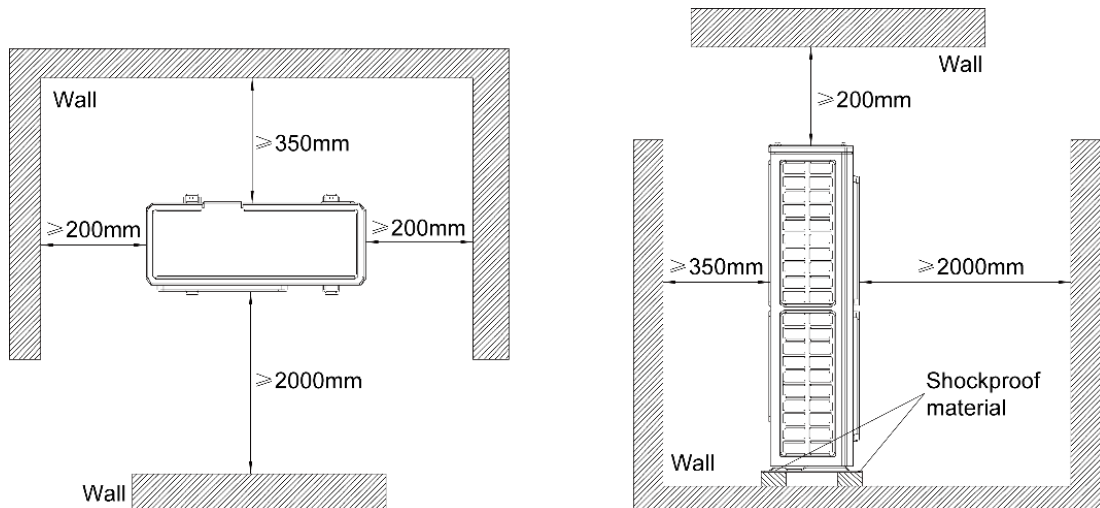

5 Pipeline design of refrigerant

5.1 Notices for pipeline design

Pipeline length and vertical fall shall within the required range, and the pipeline length and fall shall be as short as possible; when vertical fall of pipeline is too big, please set oil return loop as required;

The pipeline shall not go through the load bearing wall/beam of building.

5.2 Allowable length and fall for refrigerant pipe in IDU and ODU

| Model | Pipe dimension (mm) | | Max pipe length (m) | Max height difference between indoor unit and outdoor unit (m) |
|------------------|---------------------|-------------|---------------------|--|
| | Gas pipe | Liquid pipe | | |
| FGR20Pd/DNa-X | Φ9.52 | Φ19.05 | 70 | 30 |
| FGR25Pd/DNa-X | Φ9.52 | Φ22.2 | 70 | 30 |
| FGR30Pd/DNa-X | Φ12.7 | Φ25.4 | 70 | 30 |
| FGR40Pd/D(2)Na-X | Φ9.52 | Φ19.05 | 70 | 30 |

5.3 Design of oil loop

5.3.1 Purpose of setting oil loop

If big fall exist in the pipe, in order to prevent the problem that the refrigeration oil can't return to the compressor effectively, oil loop must be set in the vertical pipeline.

5.3.2 Principle of setting oil loop

When there's a difference between IDU and ODU, for the vertical gas pipe, an oil loop shall be installed every 10m from the bottom up.

Oil loop shall adopt two U-shaped loops or one O-shaped loop, the height is 3~5 times the size of

pipe diameter.

5.3.3 Installation notices for oil loop

For the vertical gas pipe, an oil loop shall be installed every 10m from the bottom up, meanwhile, the lowest/highest point of the vertical pipe shall be set with oil loop and check loop.

5.3.4 Manufacture requirement for oil loop and check loop

Setting and manufacture method of oil loop is as follows:

- (1) Set the oil loop as U-shape or O-shape;
- (2) If ODU is below IDU, it's needless to set oil loop at the lowest/highest point of the vertical pipe; if ODU is above IDU, then oil loop and check loop must be set separately at the lowest/highest point;
- (3) Manufacture size of oil loop is as follows:

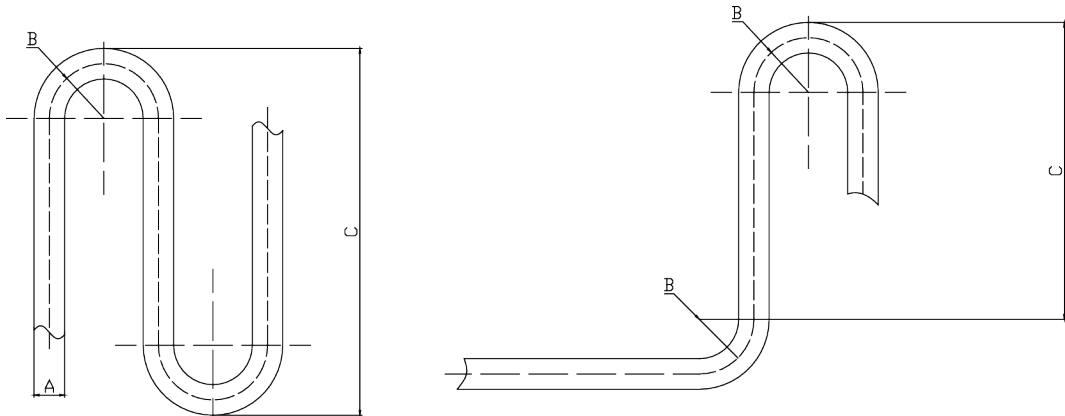

| A(mm) | B(mm) | C(mm) |
|-------|-------|-------|
| 19 | ≥34 | ≤105 |
| 22 | ≥34 | ≤150 |
| 28 | ≥45 | ≤150 |
| 35 | ≥60 | ≤250 |
| 42 | ≥80 | ≤450 |

6 Installation of drain pipe

6.1 Precautions When Doing the Piping Work

- (1) Keep piping as short as possible and slope it downwards at a gradient of at least 1/100 so that air may not remain trapped inside the pipe.

For example:

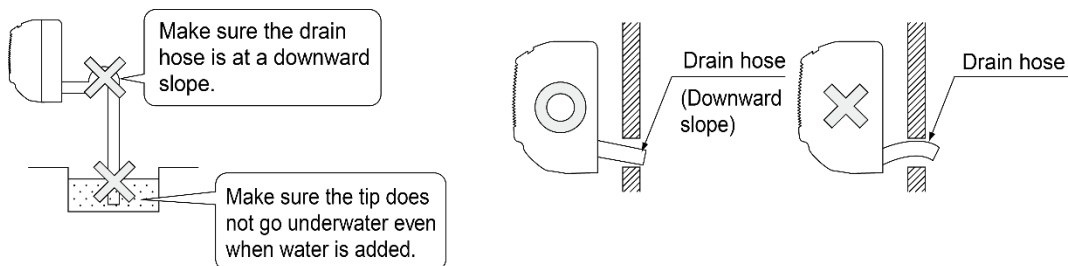

- (2) Keep pipe size equal to or greater than that of the connecting pipe.
- (3) Install the drain piping as shown and take measures against condensation. Improperly rigged piping could lead to leaks and eventually wet furniture and belongings.

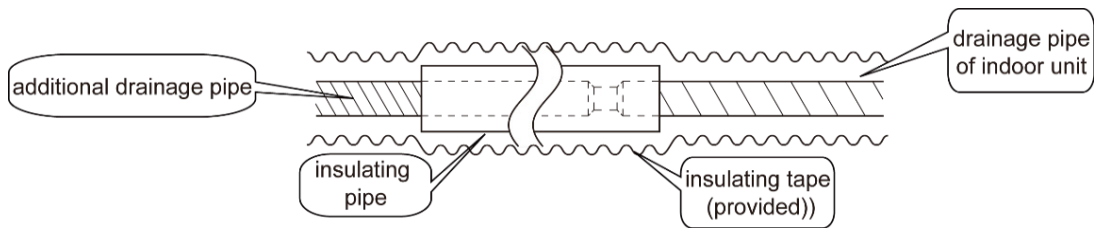

- (4) When directly connecting a hard vinyl chloride pipe joint to the drain hose connected to the indoor unit, use a commercially available hard vinyl chloride pipe joint (nominal diameter 13mm).

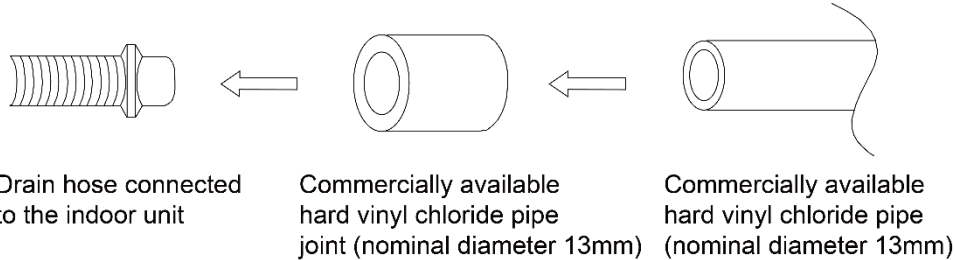

- (5) Drain hose connected to the indoor unit Commercially available hard vinyl chloride pipe joint (nominal diameter 13mm) Commercially available hard vinyl chloride pipe (nominal diameter 13mm).
- (6) Do not connect the drain piping directly to sewage pipes that smell of ammonia. The ammonia in the sewage might enter the indoor unit through the drain pipes and corrode the heat exchanger.

6.2 Installing the Drain Pipes

- (1) Insert the drain hose into the drain outlet, and tighten the clamp securely with tape.
- (2) Tighten the clamp until the screw head is less than 4 mm from the hose.

- ① . Metal clamp (accessory)
- ② . Drain hose (accessory)
- ③ . Grey tape (accessory)

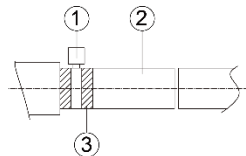

- (3) Insulate the pipe clamp and the drain hose using heat insulation sponge.

- ① . Metal clamp (accessory)
- ② . Insulation sponge (accessory)

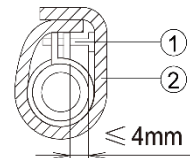

- (4) If the air flow of indoor unit is high, this might cause negative pressure and result in return suction of outdoor air. Therefore, U-type water trap shall be designed on the drainage side of each indoor unit.

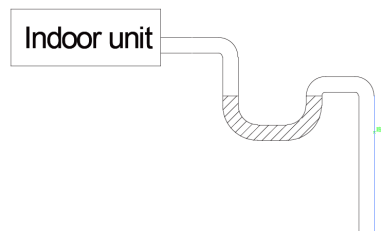

- (5) Install water trap as shown below.
- (6) Install one water trap for each unit.
- (7) Installation of water trap shall consider easy cleaning in the future.

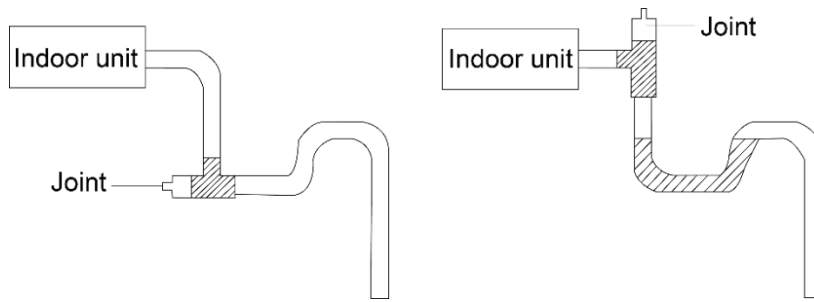

- (8) Connection of drainage branch pipe to the standpipe or horizontal pipe of drainage main pipe.
- (9) The horizontal pipe cannot be connected to the vertical pipe at a same height. It can be connected in a manner as shown below:

NO1:3-way connection of drainage pipe joint.

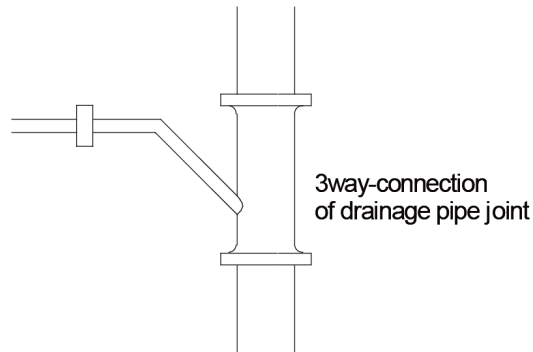

NO2: Connection of drain elbow.

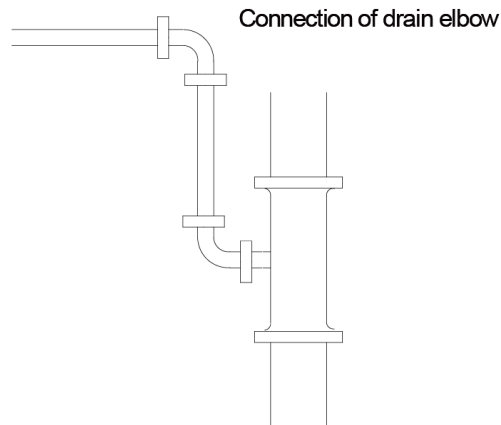

NO3: Connection of horizontal pipe.

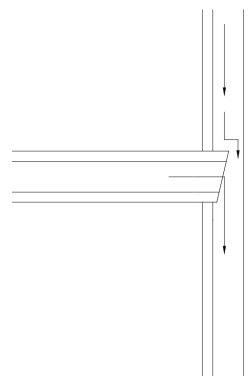

Connection of horizontal pipe

- (10) When unifying multiple drain pipes, install the pipes as shown below. Select converging drain

pipes whose gauge is suitable for the operating capacity of the unit.(take the cassette type unit for example).

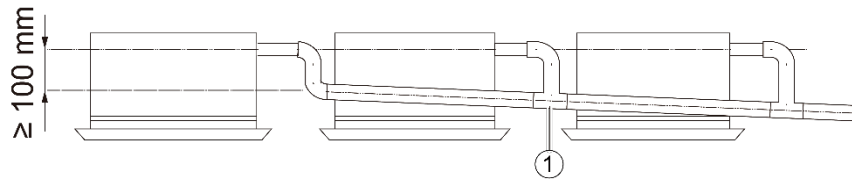

6.3 Testing of Drain Piping

- (1) After piping work is finished, check if drainage flows smoothly.
- (2) Shown in the figure, Add approximately 1liter of water slowly into the drain pan and check drainage flow during COOL running.

7 Electrical Installation

- (1) The wiring must be in accordance with the local rules.
- (2) Rated supply voltage and special circuit for air conditioner must be used.
- (3) Do not pull the power cord forcefully.
- (4) All the electric installations must be carried out by specialist technicians in accordance with the local laws, rules and these instructions.
- (5) The diameter of flexible wire should be wide enough. Replace the damaged power cord and connecting wire with special flexible wire.
- (6) The earthing shall be reliable and connected to the special earthing device on the construction. The installation must be done by specialist technicians. The leak protection switch and air switch with enough capacity must be installed. The air switch shall have both the magnetic tripping and thermal tripping functions to ensure protection against the short circuit and overload.
- (7) The air conditioner belongs to I type electric appliances. The reliable earthed action is a must.
- (8) The yellow and green wire inside the air conditioner is the earthed wire. Do not use it for other purpose or even cut off it. Do not fix it with tapping screw,. Otherwise, it may cause electric shock.
- (9) The earthed resistance must meet the requirements of local national standard.
- (10) There should be reliable earthed terminal for the power supply. Never connect the earth lead to the following articles:
 - ①water pipe; ②gas pipe; ③drain pipe; ④unreliable place considered by professionals.

DEBUGGING & MAINTENANCE

1 Debugging

1.1 Debugging flow chart

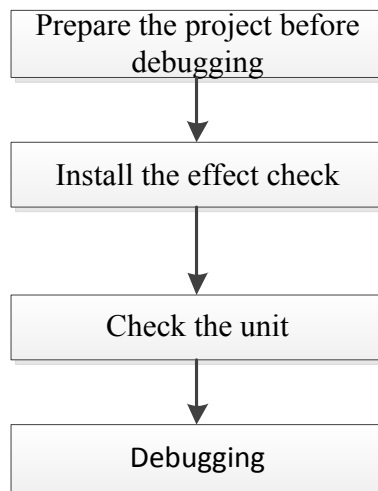

1.2 Safety notice



Warning!

- ① Take safety measure for outdoor operation. All the participated debugging and maintenance personnel must learn of the safety regulation on architecture construction, and follow the instruction strictly;
- ② Personnel of special type of work, such as refrigeration worker, electrician and welder, must have the work permit for special type of work, and they are not allowed to leave their post and visit others during work hours;
- ③ Cut off the power before conducting related operation to the equipment, meanwhile, the operation must be based on safety requirement strictly;
- ④ All installations and maintenance operations must accord with the design requirement of this product and national and local safety operation requirement;
- ⑤ It's forbidden to start the compressor compulsorily by connecting the power directly.

1.3 Preparation before debugging



Notice!

Please record those installations which are inconsistent with the specification in time, so as to provide corresponding analysis basis while testing the refrigeration system.

Inspection record before debugging.

| Inspection record before debugging | | | | | |
|------------------------------------|-----|--|---|-------------|----------|
| Type | No. | Inspection items | Reference value | Pass or not | Examiner |
| Inspect drawing | 1 | Is the drawing complete? | | | |
| | 2 | Follow the construction drawing? | | | |
| Inspect installation environment | 3 | Is there pollution source in the installation environment of ODU? Is the installation location of ODU correct? | Refer to the installation of ODU. | | |
| | 4 | Is the ODU base firm? Does vibration attenuation and water discharge meet the requirement? | Refer to the installation of ODU. | | |
| | 5 | Is the installation of basic module of ODU at the same level? | Refer to the installation of ODU. | | |
| | 6 | Is the ODU operated with static pressure? | | | |
| Inspection of refrigeration system | 7 | Does the fall between IDU and ODU meet unit design requirement? | Refer to the specification of ODU. | | |
| | 8 | For the vertical gas pipe, is the oil loop installed every 10m? | For the vertical gas pipe, one oil loop shall be installed every 10m from the top down. | | |
| | 9 | Is the opening angle of the cut off valve of ODU the widest? | Open it completely. | | |
| | 10 | Is refrigerant pressure normal? Connect the liquid pipe valve of ODU with high pressure gauge and connect the gas pipe valve of ODU with low pressure gauge, then read the corresponding the numerical value. | At this moment, the high and low pressure of the system is balanced, and the difference between saturation temperature which is corresponding to the equilibrium pressure value and ambient temperature (subject to lower value of indoor and outdoor temperature) shall not exceed 5°C, if exceeding 5°C, please check if the ODU is leaked. | | |
| | 11 | Leakage in valve? | If yes, please leakage detecting with soap or leak detector immediately to confirm the condition. After confirming, please stop the subsequent debugging right now, then re-debug it after the problem is solved. | | |
| | 12 | Before starting debugging, is the preheat time of ODU over 8h? | Before starting the unit for debugging, please ensure the ODU is energized for over 8h. | | |

| Inspection record before debugging | | | | | |
|------------------------------------|-----|---|---|-------------|----------|
| Type | No. | Inspection items | Reference value | Pass or not | Examiner |
| Electrical system inspection | 13 | Is wiring method of power cable correct? Is the wiring terminal firm? | Make sure the wiring is correct and firm. | | |
| | 14 | Is the appearance of power cable in good condition without exposure? | The appearance is in good condition, exposure is not allowed. | | |
| | 15 | Is the power capacitance less than the max power of the unit? | Greater than the max power of the unit. | | |
| | 16 | Under power outage condition, is the electrical component inside the electrical box loose? | Loose is not allowed. | | |
| | 17 | Does the IDU and ODU wire diameter meet unit design requirement? | Refer to electric installation. | | |
| | 18 | Does the circuit breaker and leakage switch meet unit design requirement? | Refer to electric installation. | | |
| | 19 | Does the supply voltage, phase sequence and frequency meet unit design requirement? | Consistent with unit nameplate, fluctuation range of voltage is within $\pm 10\%$. | | |
| | 20 | Is the distance between power cable and TV over 1m? | The distance between power cable and TV shall be over 1m. | | |
| | 21 | Are there strong electromagnetic interference, dust, acid and alkaline gas around the unit? | No battery interference, dust, acid and alkaline gas around the unit. | | |
| Communication system inspection | 22 | Does the communication wire diameter meet unit design requirement? | | | |
| | 23 | Is the communication of outdoor master unit and IDU correct? | Tandem connection. | | |
| | 24 | Is the communication connection between IDU and wired controller correct? | | | |
| | 25 | Communication cord and power cord shall not be laid in the same trunking, lay individually with inflaming retarding hard PVC pipe, and the parallel interval between communication cord and strong wire shall be over 20cm. | | | |
| IDU installation inspection | 26 | Any slope of 1/100 in drain pipe of IDU? | | | |
| | 27 | Is the lifted height of drain pipe of IDU below 85cm? | Water pump unit. | | |
| | 28 | Is drain pipe of IDU smooth? | | | |
| | 29 | Are there U-shape water loop in drain pipe of IDU? | | | |
| | 30 | Soft connection in air outlet/inlet of IDU? | Duct type unit. | | |
| | 31 | Air discharge outlet in drain pipe of IDU? | | | |



Caution:

- ① After the initial installation is finished and the main board of outdoor unit is replaced, it must perform debugging. Otherwise, the unit can't operate.
- ② The debugging must be performed by professional person or under the the guide of professional person.

1.4 Debugging Process

1.4.1 Confirm before commissioning Description

- (1) Do not disconnect the power before the installation is finished.
- (2) All wires for controller and electric wires must be connected correctly and reliably.
- (3) Check the fixing ring of the foot of compressor for transportation is removed.
- (4) Remove all sundries from the unit, such as metal chips, joint, forceps holder, and so on.
- (5) Check whether the appearance and pipeline system are damaged during carry or transportation process.
- (6) Calculate the required added refrigerant-charging volume according to the length of pipe of system and pre-charge the refrigerant. If refrigerant can't be added any more when the required refrigerant-charging volume hasn't been reached, record to refrigerant volume which still needs to be added and continue to add refrigerant during run test operation process. Please refer to below run test for the refrigerant-adding stage during run test process.
- (7) After adding refrigerant, please make sure the valve for outdoor is opened completely.
- (8) For the convenient of troubleshooting, the unit can't be connected to the PC which installed with related debugging software and make sure that the data in real time of this unit can be inspected by this computer. Please refer to Service Manual for the installation and connection of the debugging software.
- (9) Before turn test, please do make sure that the preheat time for compressor is 8h above and touch the compressor to see whether preheat is normal. You can perform run test only after normal preheat. Otherwise, it may damage the compressor.

1.4.2 Main board of ODU for Debugging

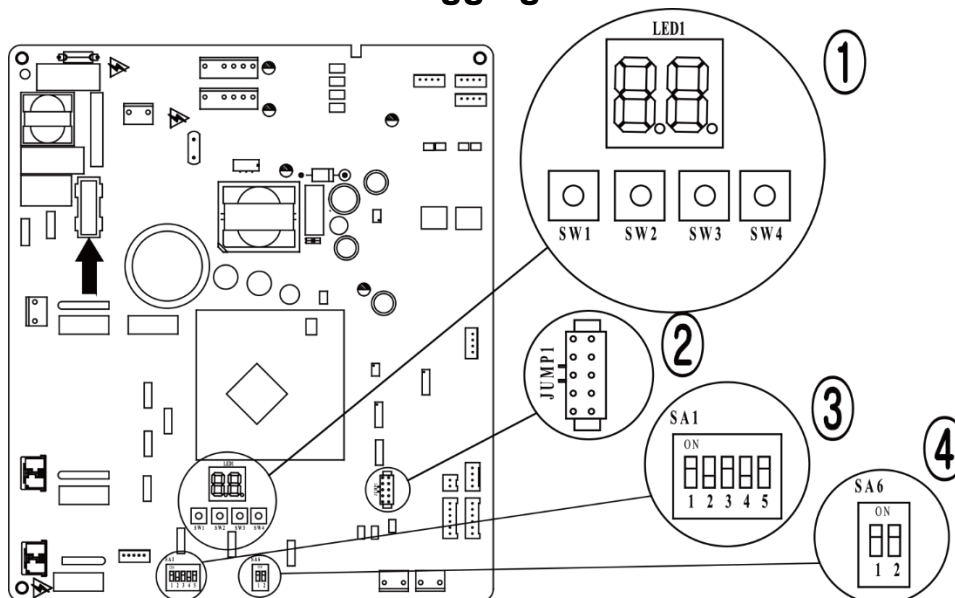

Instruction:

- (1) Indicator of main board (digital display tube) "LED1" and four button: "SW1", "SW2", "SW3" and "SW4":

| Key No. | SW1 | SW2 | SW3 | SW4 |
|----------|-----|------|-----|------|
| Function | Up | Down | OK | Back |

- (2) "JUMP1": jumper cap of the unit. Jumper cap No. varies from different type of unit.
- (3) DIP switch "SA1", DIP switch varies from different cooling capacity, before leaving the factory,

DIP switch is set for different models and fixed with glue.

- (4) The main control function DIP switch “SA6” is used to set master module and subsidiary module, the defaulted factory setting is the main module. As the fig is shown, dialing to “ON” side represents “0” and dialing to the figure side represents “1”, the defaulted setting for the unit is “00”. For the system with two outdoor units, one of them shall be set as the main module, namely,

| Function | SA6 | |
|-------------------|-----|---|
| | 1 | 2 |
| Master module | 0 | 0 |
| Subsidiary module | 1 | 0 |

S A 6

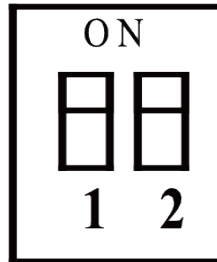

dial “SA6” to “00”, then set the other unit as subsidiary module, namely, dial the “SA6” to “10”.

1.4.3 Basic operation of project debugging

- (1) Start project debugging

Press “SW3” button consecutively in the master module for over 5s to enter auto debugging.

- (2) Exit project debugging

After entering project debugging, press “SW3” button consecutively in the master module for over 5s to exit the debugging.

- (3) Complete project debugging

After entering project debugging and completing step “04”, press “SW2” and “SW3” button consecutively in the master module for over 5s to exit the debugging, then the system can operate normally.

Flow-process diagram of debugging:

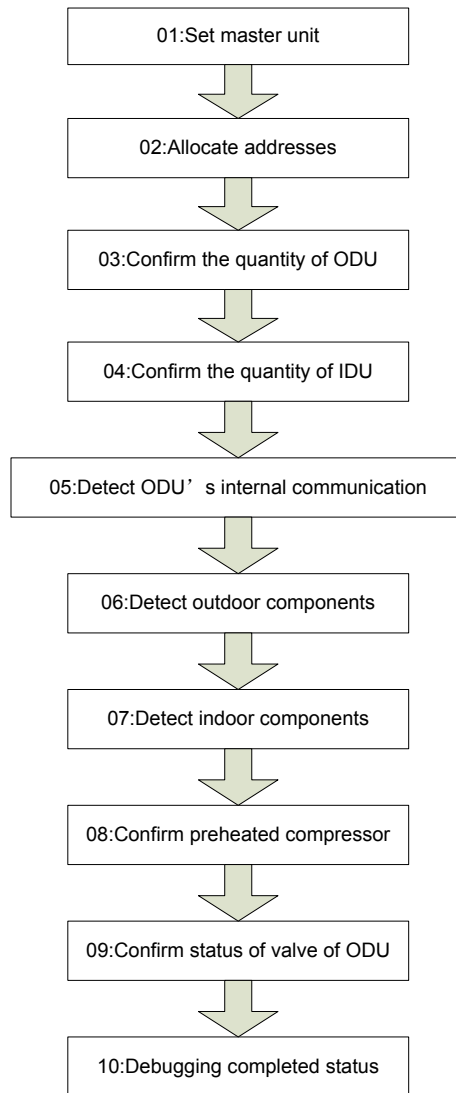

1.4.4 Debugging process

(1) Unit manufactured before Oct 30,2018.

Debugging procedure for test run, display instruction for indicator on main board of outdoor unit and operation method are as below:

| Description of each stage of debugging progress | | | |
|---|----------------|--------------------|--|
| Progress | Debugging Code | | Instruction for Code and Operating Method |
| | LED | | |
| | Display Code | Display Code | |
| Start | A0 | Always ON | No debugged yeat. Press "SW3" button consecutively in the master module for over 5s to enter auto debugging. |
| 01_ Set master unit | 01/CC | Display repeatedly | There is no master unit in the system. The system cannot continue to conduct debugging, and all the buttons are invalid that must be reset by cutting the power. |
| | 01/CF | Display repeatedly | There are two or more master units in the system. The system cannot continue to conduct debugging, and all the buttons are invalid that must be reset by cutting the power. Please set the correct "SA6" DIP switch. |
| | 01/oC | Display repeatedly | There is only one master unit in the system. The unit will automatically enter into the next step after displaying for once. |

| Description of each stage of debugging progress | | | |
|---|------------------------------|--------------------|---|
| Progress | Debugging Code | | Instruction for Code and Operating Method |
| | LED | | |
| | Display Code | Display Code | |
| 02_ Allocate addresses | 02 | Flicker | The system is allocating addresses. It will display as below after 10 seconds. |
| | 02/L7 | Display repeatedly | There is no master unit. The display will last for 1 minute, within this 1 minute, the master IDU can be set by debugging software. If the master IDU has not been set within this 1 minute, the system will automatically set the IDU with the minimum IP address as the master IDU. |
| | 02/oC | Display repeatedly | The system has finished allocating the addresses, there is master IDU. It will automatically enter into the next step's operation after displaying for once. |
| 03_ Confirm the quantity of ODU | 03/QTY of module | Display repeatedly | Confirmation of quantity of modules in the system. To differentiate from the debugging step, the QTY of module will display only 1-digit on the right. If the actual quantity of ODU is in conformity with the displayed quantity, please check the dial code and wire connection and then conduct debugging for confirmation. |
| | 03/oC | Display repeatedly | If the actual quantity of ODU is in conformity with the displayed quantity, press SW3 button to confirm. After confirmation, all the module nixie tubes will repeatedly display "03" and "0C", after displaying for once, the system will automatically enter into the next operation. |
| 04_ Confirm the quantity of IDU | 04/Cb | Display repeatedly | It is not allowed to connect more than one indoor unit in the system. Please check and debug again to confirm. |
| | 04/oC | Display repeatedly | The quantity of IDU in the system has been confirmed. It will enter into the next step. |
| 05_ Detect ODU's internal communication | 05/C2 | Display repeatedly | Communication error between master control and drive of compressor. Please check if the communication wire between mainboard and driving board of ODU is correctly connected, if it is, enter into the next step. If the ODU should be powered off for the debugging, after re-energizing the unit, please conduct debugging from the above 01 step. |
| | 05/oC | Display repeatedly | The communication between master control and driving of ODU is normal. After displaying for once, it will automatically enter into the next step. |
| 06_ Detect outdoor components | 06/corresponding error code | Display repeatedly | Error of components of ODU. After eliminating all the errors, it will automatically enter into the next step. If the ODU should be powered off for the debugging, after re-energizing the unit, please conduct debugging from the above 01 step. |
| | 06/corresponding error code | Display repeatedly | Error of components of ODU. After eliminating all the errors, it will automatically enter into the next step. If the ODU should be powered off for the debugging, after re-energizing the unit, please conduct debugging from the above 01 step. |
| | 06/oC | Display repeatedly | No component of ODU is found in the system, it will enter into the next step 10 seconds later. |
| 07_ Detect indoor components | 07/ corresponding error code | Display repeatedly | Error of components of IDU is detected. If the ODU should be powered off for the debugging, after re-energizing the unit, please conduct debugging from the above 01 step. |
| | 07/oC | Display repeatedly | No component of IDU is found in the system. It will automatically enter into the next step 5 seconds later. |

| Description of each stage of debugging progress | | | |
|---|----------------|--------------------|--|
| Progress | Debugging Code | | Instruction for Code and Operating Method |
| | LED | | |
| | Display Code | Display Code | |
| 08_ Confirm preheated compressor | 08/U0 | Display repeatedly | Insufficiency preheating of compressor. If the consecutive energization time of all basic modules detected at present is over or equal to 8h, or the discrepancy between the moment when the last consecutive energization time is over or equal to 8h and current time is less than 2h, it means preheat is complete, otherwise, it means preheating is insufficient, direct startup will damage the compressor. At this time, short press SW3 to skip the waiting time to automatically enter the next step. |
| | 08/oC | Display repeatedly | Sufficient preheating of compressor. After displaying once circularly, the system will enter the next step automatically. |
| 09_ Confirm status of valve of ODU | 09/oF | Display repeatedly | Standby status, ready to start. |
| | 09/on | Display repeatedly | The system has started. |
| | 09/U6 | Display repeatedly | The system shuts down due to malfunction. The error module nixie tube repeatedly display "09" and "U6", other module nixie tubes repeatedly display "09" and "J0". If error occurs, please check if the valve is opened, and at the same time check if the connecting pipes between different modules are correctly connected. |
| | 09/oC | Display repeatedly | Confirmation on valve status is complete. All the modules shut down, then all the module nixie tube will display once. |
| 10_ Debugging completed | OFF | ON | Debugging is completed, the system is in standby status. |

(2) Unit manufactured after Oct 30,2018.

Debugging procedure for test run, display instruction for indicator on main board of outdoor unit and operation method are as below:

| Description of each stage of debugging progress | | | |
|---|---------------------------------------|--------------------|--|
| Progress | Debugging code | | Instruction for Code and Operating Method |
| | LED | | |
| | Display code | Display status | |
| Start | A0 | Always ON | No debugged yeat. Press "SW3" button consecutively in the master module for over 5s to enter auto debugging. |
| 01_Master unit setting | 01/CC | Display repeatedly | The system has no master unit. Debugging can't be continued, all buttons are invalid, disconnect the power to reset the correct "SA6" DIP. |
| | 01/CF | Display repeatedly | The system has two or more master units. Debugging can't be continued, all buttons are invalid, disconnect the power to reset the correct "SA6" DIP. |
| | 01/oC | Display repeatedly | The system has only one master unit. After displaying once circularly, the system will enter the next step automatically. |
| 02_Address allocation | 02 | Blink | The system is allocating address, which might takes 10s. |
| | 02/L7 | Display repeatedly | No master indoor unit. It will display for 1min continuously. The user can set master through debugging the software within 1min. If no master unit is set manually within 1min, the system will set the indoor unit with the smallest IP address automatically as the master indoor unit. |
| | 02/oC | Display repeatedly | Address allocation of the system is complete with master indoor unit. After displaying once circularly, the system will enter the next step automatically. |
| 03_Confirm quantity of outdoor units | 03/ quantity of modules in the system | Display repeatedly | Confirmation of quantity of modules in the system. To differentiate from the debugging step, the QTY of module will display only 1-digit on the right. |
| | 03/oC | Display repeatedly | After 10S, all the nixie tubes of modules will display "03" and "oC", after displaying once circularly, the system will enter the next step automatically. |
| 04_Confirm quantity of indoor units | 04/Cb | Display repeatedly | The quantity of indoor unit is more than 1. The system shall not connect more than 1 indoor unit, after inspection, please redebug for confirmation. |
| | 04/oC | Display repeatedly | The quantity of indoor unit is 1. After confirming the quantity of indoor unit, it will enter the next step 2s later. |
| 05_Internal communication of outdoor unit | 05/C2 | Display repeatedly | Communication error between master control and compressor drive. Please check the connection between the main board of outdoor unit and communication cord of drive board, after eliminating the errors, enter the next step. If the ODU should be powered off for troubleshooting, after re-energizing the unit, please conduct debugging from the above 01 step. |
| | 05/oC | Display repeatedly | Communication between the master control of outdoor unit and drive is normal. After displaying once circularly, the system will enter the next step automatically. |
| 06_Component detection of outdoor unit | 06/ Corresponding error code | Display repeatedly | Component error of outdoor unit. After eliminating all the errors, enter the next step automatically, if the ODU should be powered off for troubleshooting, after re-energizing the unit, please conduct debugging from the above 01 step. |
| | 06/oC | Display repeatedly | No component error of outdoor unit. After displaying for 10s circularly, the system will enter the next step automatically. |

| Description of each stage of debugging progress | | | |
|---|---------------------------------|--------------------|--|
| Progress | Debugging code | | Instruction for Code and Operating Method |
| | LED | | |
| | Display code | Display status | |
| 07_ Component inspection of indoor unit | 07/ Corresponding error code | Display repeatedly | Component error of indoor unit. After eliminating all the errors, enter the next step automatically, if the ODU should be powered off for troubleshooting, after re-energizing the unit, please conduct debugging from the above 01 step. |
| | 07/oC | Display repeatedly | No component error of indoor unit. After displaying for 5s circularly, the system will enter the next step automatically. |
| 08_ Preheat confirmation of compressor | 08/oC | Display repeatedly | After displaying for 2s circularly, the system will enter the next step automatically. |
| 09_ Confirmation of valve of outdoor unit | 09/oF | Display repeatedly | Standby status, ready to start. |
| | 09/on | Display repeatedly | The system has started. |
| | 09/U6 | Display repeatedly | Malfunction shutdown. The nixie tube of faulted module will display "09" and "U6" repeatedly and the nixie tube of other modules will display "09" and "J0". In case malfunction occurred, please check if the valve is opened and if the connection pipes among different modules are correctly connected. |
| | 09/oC | Display repeatedly | Confirmation of valve status. All modules are halted normally, nixie tubes of all modules will display once circularly. |
| 10_ Debugging completed | OFF | ON | Debugging is completed, the system is in standby status. |

1.5 Function setting

1.5.1 Function setting of outdoor unit

After debugging, long press "SW1" button in master control for 5s, the system will enter function standby status, main board indicator of outdoor unit is displayed acquiescently as follows:

| LED | |
|---------------|----------------|
| Function code | Display method |
| A7 | Blink |

Select corresponding function to switch LED function code through "SW1" and "SW2" button in master control, function setting includes: outdoor quiet mode setting (A7), unit cooling and heating function setting (A6), mandatory defrosting operation (n3) and energy conservation mode setting (n0).

After selecting corresponding function, short press "SW3" button for confirmation, main board indicator of outdoor unit is displayed as follows:

| LED | |
|---------------|----------------|
| Function code | Display method |
| A7 | Blink |
| A6 | Blink |
| n3 | Blink |
| n0 | Blink |

1.5.2 Quiet function of outdoor unit

This function applies to project with high requirements for noise of outdoor unit, after entering function setting (A7), main board indicator of outdoor unit is displayed as follows:

| LED | |
|---------------|----------------|
| Function code | Display method |

| LED | |
|------------------|-------|
| 00, 10, 11 or 12 | Blink |

Select corresponding quiet mode through “SW1” and “SW2”, short press “SW3” to confirm the selected mode.

Note: code 00 is the normal mode, code 10~12 is the compulsory quiet mode, the bigger the numerical value is, the better quiet effect is. After setting is completed, the master control unit will memorize the setting, and the setting shall not be cleared even after power outage and energization. The defaulted factory setting for the unit is 00.

1.5.3 Unit cooling and heating function setting

This function can conduct compulsory setting to unit operation mode, after entering function setting (A6), main board indicator of outdoor unit is displayed as follows:

| LED | |
|-------------------|----------------|
| Function code | Display method |
| nC / nH / nA / nF | Blink |

Select corresponding quiet mode through “SW1” and “SW2”, short press “SW3” to confirm the selected mode.

Note: “nA” is cooling and heating type; “nC” means cooling only; nH means heat pump; “nF” means air supply; After setting is completed, the master control unit will memorize the setting, and the setting shall not be cleared even after power outage and energization.

1.5.4 Mandatory defrosting operation

Mandatory defrosting setting is only effective if the compressor of outdoor unit is operating, after entering the function setting (n3), main board indicator of outdoor unit is displayed as follows:

| LED | |
|---------------|----------------|
| Function code | Display method |
| n3 | Blink |

Short press “SW3” to confirm, at this time, the unit will enter mandatory defrosting mode, once entering mandatory defrosting mode, the exist of the system must meet the defrosting exist condition, other operations are invalid.

1.5.5 Energy conservation operation setting

The function enables the unit to operate in energy conservation mode, after entering function setting (n0), main board indicator of outdoor unit is displayed as follows:

| LED | |
|---------------|----------------|
| Function code | Display method |
| 01/02 | Blink |

Select corresponding quiet mode through “SW1” and “SW2”, short press “SW3” to confirm the selected mode.

Note: the defaulted factory setting is “capacity comes first”, namely “01”, which means the capacity shall control preferentially, “02” means the master control unit will memorize the setting after setting energy conservation control preferentially, and the setting will not be cleared after re-energization.

1.5.6 Reset factory setting

(1) Reset defaulted factory setting 1 (clear all settings):

Long press “SW1 + SW4” button for over 10s in the main module, the nixie tube will display “oC” for

3s, the main board will remove all settings, including IP address of indoor and outdoor unit.

(2) Reset defaulted setting 2 (clear all settings other than project debugging status):

Long press “SW2 + SW4” for over 10s in the main module, the nixie tube will display “oC” for 5s, the main board will remove all settings, including IP address of indoor and outdoor unit, but completion label for project debugging and the memory of indoor and outdoor unit quantity shall be kept.

(3) Reset defaulted setting 3 (clear function setting of outdoor unit only):

Long press “SW3 + SW4” for over 10s in the main module, the nixie tube will display “oC” for 7s, then clear all function settings of the system, but project code of indoor and outdoor unit, the memory of indoor and outdoor unit quantity and completion label for project debugging shall be kept.

2 Troubleshooting

| Display code | Content | Display code | Content | Display code | Content |
|--------------|---|--------------|---|--------------|---|
| L0 | Malfunction of indoor unit | L9 | Wrong number of indoor unit for one-to-more indoor unit | d8 | Malfunction of water temperature sensor |
| L1 | Indoor fan protection | LA | Wrong series for one-to-more indoor unit | d9 | Malfunction of jumper cap |
| L2 | E-heater protection | LH | Alarming due to bad air quality | dA | Abnormal address for indoor unit |
| L3 | Water overflow protection | LC | The indoor unit model can't match with outdoor unit model | dH | Abnormal PCB for wired controller |
| L4 | Power supply of wired controller is faulted | d1 | Poor indoor PCB | dC | Abnormal code-dialing setting of capacity |
| L5 | Freeze prevention protection | d3 | Malfunction of ambient temperature sensor | dL | Malfunction of air exhaust temperature sensor |
| L6 | Mode shock | d4 | Malfunction of entry tube temperature sensor | dE | Malfunction of indoor CO ₂ sensor |
| L7 | No main indoor unit | d6 | Malfunction of exit tube temperature sensor | C0 | Communication malfunction |
| L8 | Insufficient power supply | d7 | Malfunction of humidity sensor | AJ | Clean alarming for filter |
| db | Special code: engineering debugging code | | | | |

| Display code | Content | Display code | Content | Display code | Content |
|--------------|--|--------------|--|--------------|--|
| E0 | Malfunction of outdoor unit | E1 | High pressure protection | E2 | Low-temperature protection for discharge |
| E3 | Low pressure protection | E4 | Discharge high temperature protection for compressor | EC | Loose protection for discharge temperature sensor for compressor 1 |
| F0 | Poor main board of outdoor unit | F1 | Malfunction of high pressure sensor | F3 | Malfunction of low pressure sensor |
| F5 | Malfunction of discharge temperature sensor for compressor 1 | J0 | Other module protection | J1 | Overcurrent protection for compressor 1 |
| J7 | Air-mixing protection for 4-way valve | J8 | High pressure ration protection of system | J9 | Low pressure ratio protection of system |
| JL | High pressure is too low | b1 | Malfunction for outdoor ambient temperature sensor | b2 | Malfunction of defrosting temperature sensor 1 |
| b3 | Malfunction of defrosting temperature sensor 2 | b4 | Malfunction of liquid temperature sensor for subcooler | b5 | Malfunction of gas temperature sensor for subcooler |

| Display code | Content | Display code | Content | Display code | Content |
|--------------|--|--------------|---|--------------|---|
| b6 | Malfunction for temperature sensor of inlet tube of gas and liquid separator | b7 | Malfunction for temperature sensor of exit tube of gas and liquid separator (exit tube A) | b9 | Malfunction of gas exit temperature sensor for heat exchanger |
| bH | Abnormal clock of system | P0 | Malfunction driven board for compressor | P1 | Driven board of compressor works abnormally |
| P2 | Power voltage protection for the driven board of compressor | P3 | Reset protection for the driven module of compressor | P4 | Driven PFC protection of compressor |
| P5 | Overcurrent protection for inverter compressor | P6 | Driven IPM module protection for compressor | P7 | Malfunction of driven temperature sensor for compressor |
| P8 | Overheating protection for driven IPM of compressor | P9 | Desynchronizing protection for inverter compressor | PH | High voltage protection for driven DC bus bar of compressor |
| PC | Circuit malfunction of driven current detection for compressor | PL | Low voltage protection for driven DC bus bar of compressor | PE | Phase-losing of inverter compressor |
| PF | Malfunction of driven charging loop for compressor | PJ | Failure start up for inverter compressor | PP | AC current protection for inverter compressor |
| U0 | Preheat time is not enough for compressor | U2 | Capacity code of outdoor unit/wrong setting of jumper cap | U4 | Insufficient refrigerant protection |
| U5 | Wrong address for the driven board of compressor | U6 | Alarm due to abnormal valve | U8 | Malfunction of pipeline for indoor unit |
| U9 | Malfunction of pipeline for outdoor unit | UC | Setting for indoor unit and outdoor unit is succeeded | UL | Wrong code-dialing during emergency operation |
| UE | Refrigerant-charging is invalid | C0 | Communication malfunction for indoor unit, outdoor unit and wired controller of indoor unit | C2 | Driven communication malfunction between main board and inverter compressor |
| C3 | Driven communication malfunction between main board and inverter compressor | C4 | Malfunction of indoor unit-lacking | C5 | Alarming due to engineering series number shock of indoor unit |
| C6 | Alarming due to wrong quantity of outdoor unit | C8 | Emergency status of compressor | C9 | Emergency status of fan |
| CA | Emergency status of module | CH | High rated capacity | CC | No malfunction of main control unit |
| CL | Low rated capacity | CF | Malfunction of main control unit | CJ | Address shock of system |
| CU | Communication malfunction between indoor unit receiving lamp board | Cb | Distribution overflow of Ip address | A0 | Debugging for unit |
| A1 | Operational parameter inquiry of compressor | A2 | Refrigerant recovery | A3 | Defrosting |
| A4 | Oil return | A5 | On-line test | A6 | Heat pump function setting |
| A7 | Quit mode setting | A8 | Vacuum pump mode | A9 | IPLV test |
| AA | EU AA class energy efficiency test mode | AH | Heating | AL | Charge refrigerant automatically |
| AE | Charge refrigerant by hand | AF | Fan blow | AJ | Cleaning alarm for filter |

| Display code | Content | Display code | Content | Display code | Content |
|--------------|---|--------------|---|--------------|---|
| AP | Startup debugging confirmation of unit | AU | Long-distance emergency stop | Ab | Emergency stop |
| Ad | Limit operation | n0 | SE setting for the operation | n1 | Defrosting period K 1 setting |
| n2 | Upper limit setting for the collocation matching ratio for indoor unit and outdoor unit | n4 | Limit setting for the maximum output capacity | n6 | Engineering series number inquiry for indoor unit |
| n7 | Malfunction inquiry | n8 | Parameters inquiry | nA | Heat pump unit |
| nH | Heating only model | nC | Cooling only model | nE | Negative code |
| nF | Fan model | | | | |

(1) "A0" debugging for unit



Fault display: the main board of outdoor unit and indoor unit will display

Applicable model: all models.

Judgment condition and method for the fault: It is a status code. If engineering debugging is not finished, the unit will display the code, at this time, the unit can't be started for operation.

Possible reason: the unit is energized for startup for the first time, new main board is replaced for the unit.

Troubleshooting: refer to the complete unit debugging in related chapter.

(2) "A3" defrosting



Fault display: the main board of outdoor unit and indoor unit will display

Applicable model: all heat pump models.

Judgment condition and method for the fault: It is a status code, which means the system has entered defrosting status, the indoor fan will suspend for 5-10min.

Possible reason: the outside ambient temperature is low, after heating for a long period, frosting at the outside heat exchanger is quite thick.

Troubleshooting: not faulted.

(3) "A4" oil return



Fault display: the main board of outdoor unit and indoor unit will display

Applicable model: all models.

Judgment condition and method for the fault: It is a status code, which means the system has entered oil return status, if the oil returns under heating mode, the indoor fan will suspend for 5-10min.

Possible reason: the load for the air conditioner is low, unit compressor has been operating in low frequency for a long time.

Troubleshooting: not faulted.

(4) "A6" cooling/heating function setting



Fault display: the main board of outdoor unit will display

Applicable model: all models.

Judgment condition and method for the fault: It is a status code, which means the system has entered cooling/heating function setting status, at this time, choose cooling/heating (nA), cooling only (nC), heating only (nH) and fan blow (nF) for setting.

Possible reason: ——

Troubleshooting: not faulted.

(5) “A7” quiet mode setting



Fault display: the main board of outdoor unit will display

Applicable model: all models.

Judgment condition and method for the fault: It is a status code, which means the system has entered quiet mode setting status.

Judgment condition and method for the fault: ——

Troubleshooting: ——

(6) “AH” heating



Fault display: the main board of outdoor unit will display

Applicable model: all models.

Judgment condition and method for the fault: It is a status code, which means the system has entered heating mode setting status.

Possible reason: ——

Troubleshooting: ——

(7) “AC” cooling



Fault display: the main board of outdoor unit will display

Applicable model: all models.

Judgment condition and method for the fault: It is a status code, which means the system has entered cooling mode setting status.

Possible reason: ——

Troubleshooting: ——

(8) “AF” fan blow



Fault display: the main board of outdoor unit will display

Applicable model: all models.

Judgment condition and method for the fault: It is a status code, which means the system has

entered fan blow mode, at this time, the indoor unit can only operate in fan blow mode.

Possible reason: ——

Troubleshooting: ——

(9) “AJ” cleaning alarm for filter



Fault display: the indoor unit will display .

Applicable model: all indoor units.

Judgment condition and method for the fault: It is a status code, which means cleaning alarm for indoor unit filter is due, the filter shall be cleaned, and the period can be set according to actual operation circumstances.

Possible reason: ——

Troubleshooting: Clean the filter and remove the alarm, then enter the next usage period.

(10) “AU” remote emergency stop



Fault display: the main board of outdoor unit and indoor unit will display .

Applicable model: all models.

Judgment condition and method for the fault: It is a status code, which means the unit is controlled in emergency stop status remotely, unless eliminating the status, otherwise, the unit can't be started.

Possible reason: ——

Troubleshooting: ——

(11) “Ab” emergency stop



Fault display: the main board of outdoor unit and indoor unit will display .

Applicable model: all models, but extra wiring is needed.

Judgment condition and method for the fault: It is a status code, which means the main board of outdoor unit has received emergency stop signal, unless eliminating the status, otherwise, the unit can't be started.

Possible reason: ——

Troubleshooting: ——

(12) “Ad” limit operation



Fault display: the main board of outdoor unit and indoor unit will display .

Applicable model: all models.

Judgment condition and method for the fault: It is a status code, which means emergency operation status is set, however, emergency operation time has exceeded the limit requirement, at this time, the unit is not allowed to conduct emergency operation.

Possible reason: ——

Troubleshooting: ——

(13) “b1” malfunction of outdoor ambient temperature sensor



Fault display: the main board of outdoor unit and indoor unit will display

Applicable model: all outdoor units.

Judgment condition and method for the fault:

Sample the AD value of temperature sensor through temperature sensor detecting circuit and judge the range of AD value, if the sampling AD value exceeds upper limit and lower limit in 30 seconds continuously, report the error.

Possible reason:

- 1) Poor contact between ambient temperature sensor and terminal in mainboard interface.
- 2) Temperature sensor is abnormal.
- 3) The detected circuit is abnormal.

Troubleshooting:

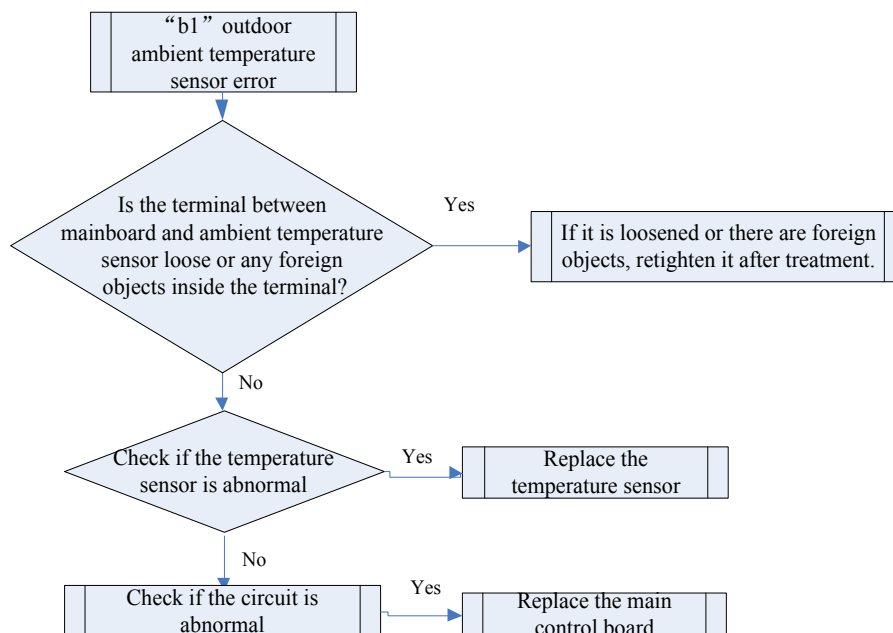

(14) “b2” malfunction of defrosting temperature sensor 1



Fault display: the main board of outdoor unit and indoor unit will display

Applicable model: all outdoor units.

Judgment condition and method for the fault:

Sample the AD value of temperature sensor through temperature sensor detecting circuit and judge the range of AD value, if the sampling AD value exceeds upper limit and lower limit in 30 seconds continuously, report the error.

Possible reason:

- 1) Poor contact between ambient temperature sensor and terminal in mainboard interface.
- 2) Temperature sensor is abnormal.
- 3) The detected circuit is abnormal.

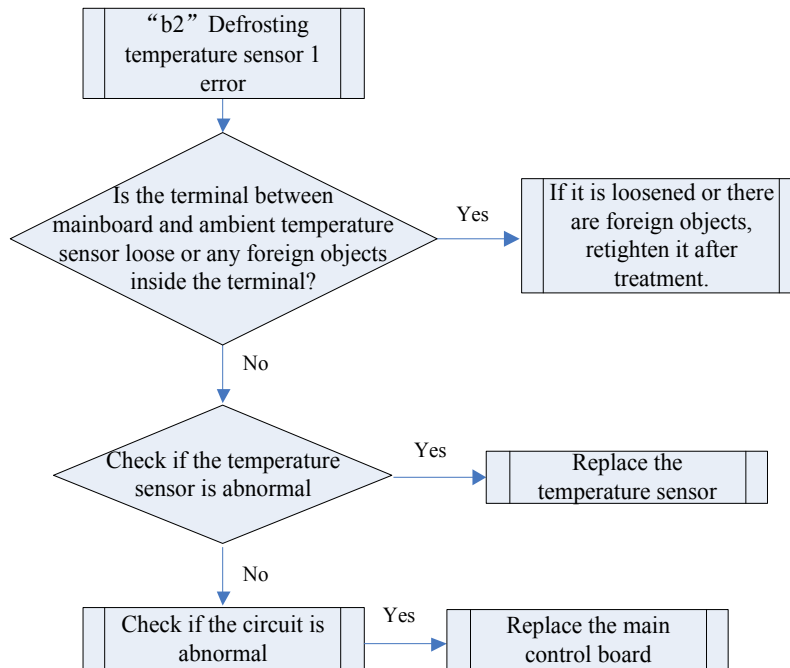
Troubleshooting:**(15) "b9" malfunction of gas exit temperature sensor for heat exchanger**

Fault display: the main board of outdoor unit and indoor unit will display .

Applicable model: all outdoor units.

Judgment condition and method for the fault:

Sample the AD value of temperature sensor through temperature sensor detecting circuit and judge the range of AD value, if the sampling AD value exceeds upper limit and lower limit in 30 seconds continuously, report the error.

Possible reason:

- 1) Poor contact between ambient temperature sensor and terminal in mainboard interface.
- 2) Temperature sensor is abnormal.
- 3) The detected circuit is abnormal.

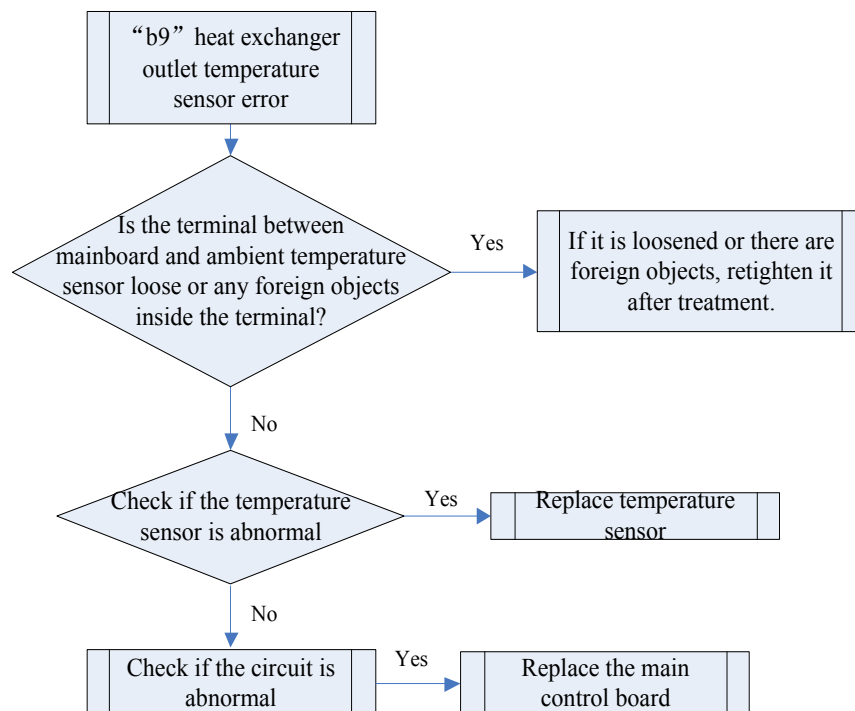
Troubleshooting:**“C2” driven communication malfunction between main board and inverter compressor**

Fault display: the main board of outdoor unit and indoor unit will display .

Applicable model: all outdoor units.

Judgment condition and method for the fault: The outdoor unit cannot detect the data of inverter compressor drive board in 30s, then it will give alarm.

Possible reason:

- 1) The communication cable is not correctly connected.
- 2) The inverter compressor drive board is abnormal.
- 3) The main board is abnormal.

Troubleshooting:

- 1) Check if the cable connecting the control board and the compressor's drive board is loose. If yes, reconnect it;
- 2) Check if the cable connecting the control board and compressor's drive board is broken. If yes, replace the cable;
- 3) Check the contact of the communication cable connecting the control board and compressor's drive board;
- 4) Replace the control board. If the fault is solved, the control board is faulty. Replace the compressor's drive board. If the fault is solved, the compressor's drive board is faulty.

(16) “C6” alarming due to wrong quantity of outdoor unit

Fault display: the main board of outdoor unit and indoor unit will display .

Applicable model: all outdoor units.

Judgment condition and method for the fault: The system will detect the quantity of online outdoor module at real time. When the detected quantity of current module is inconsistent with the one memorized by previous debugging, the unit will give alarm and stop the unit for protection.

Possible reason:

- 1) Communication among modules is abnormal.
- 2) No electricity for the module.

Troubleshooting:

- 1) If the communication cable is loose, reconnect it.
- 2) If the communication cable is broken, replace it.
- 3) Check contact of the communication cable.
- 4) Replace the control board.

(17) “CC” malfunction of no main control unit

Fault display: the main board of outdoor unit and indoor unit will display .

Applicable model: all outdoor units.

Judgment condition and method for the fault: The main board will detect the dial-code of master control unit (SA6) to judge if it is the master control unit.

Possible reason:

- 1) Switch the SA6 dial switch of an ODU to 00.
- 2) Replace the control board or switch an ODU's SA6 dial switch to 00.

(18) “d1” Indoor circuit board error

Error display: wired controller of IDU and the dash receiver of IDU will display .

Applicable mode: all indoor units.

Error judgment condition and method: Check if the reading of address chip and memory chip of IDU mainboard is normal. If the data of address chip and memory chip cannot be read, it is abnormal.

Possible reason:

- 1) Address chip is abnormal.
- 2) Memory chip is abnormal.

Troubleshooting:

Replace main control board directly.

(19) “d3” Ambient temperature sensor error

Error display: wired controller of IDU and the dash receiver of IDU will display .

Error judgment condition and method:Sample the AD value of temperature sensor through temperature sensor detecting circuit and judge the range of AD value, if the sampling AD value exceeds upper limit and lower limit in 5 seconds continuously, report the error.

Possible reason:

- 1) Poor contact between ambient temperature sensor and terminal in mainboard interface.
- 2) Ambient temperature sensor is abnormal.
- 3) Detecting circuit is abnormal .

(20) “d4” Inlet pipe temperature sensor error



Error display: wired controller of IDU and the dash receiver of IDU will display

Error judgment condition and method:Sample the AD value of temperature sensor through temperature sensor detecting circuit and judge the range of AD value. If the sampling AD value exceeds upper limit and lower limit in 5 seconds continuously, report the error.

Possible reason:

- 1) Poor contact between inlet pipe temperature sensor and terminal in mainboard interface.
- 2) Inlet pipe temperature sensor is abnormal.
- 3) Detecting circuit is abnormal.

(21) “d5” midst pipe temperature sensor error



Error display: IDU displays

Applicable mode: all indoor units.

Error judgment condition and method:Sample the AD value of temperature sensor through temperature sensor detecting circuit and judge the range of AD value. If the sampling AD value exceeds upper limit and lower limit in 5 seconds continuously, report the error.

Possible reason:

- 1) Poor contact between midst pipe temperature sensor and terminal in mainboard interface.
- 2) Midst pipe temperature sensor is abnormal.
- 3) Detecting circuit is abnormal.

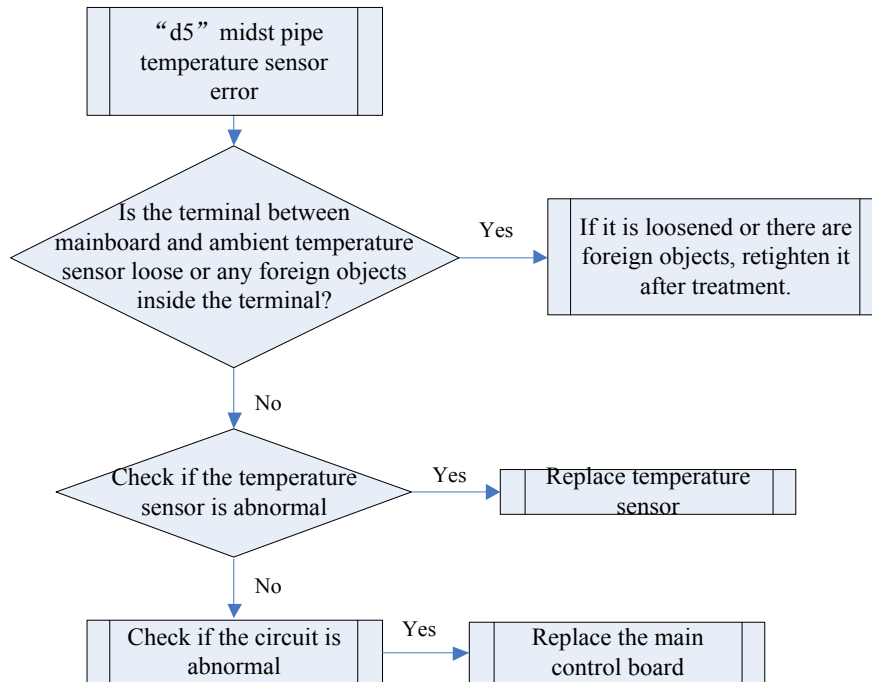
Troubleshooting:**(22) “d6” Outlet pipe temperature sensor error**

Error display: IDU displays .

Error judgment condition and method:

Sample the AD value of temperature sensor through temperature sensor detecting circuit and judge the range of AD value. If the sampling AD value exceeds upper limit and lower limit in 5 seconds continuously, report the error.

Possible reason:

- 1) Poor contact between outlet pipe temperature sensor and terminal in mainboard interface.
- 2) Outlet pipe temperature sensor is abnormal.
- 3) Detecting circuit is abnormal.

(23) “d9” Jumper cap error

Error display: IDU displays .

Error judgment condition and method:**Possible reason:**

If jumper cap model doesn't match with mainboard, report the error:

- 1) Jumper cap is not installed.
- 2) Jumper cap model is wrong.
- 3) Detecting circuit is abnormal.

(24) “dC” Capacity DIP switch setting error

Error display: wired controller of IDU and the dash receiver of IDU will display

Error judgment condition and method:

If capacity DIP switch is set to the wrong position, report the error.

Possible reason:

- 1) Capacity DIP switch is set to the wrong position.
- 2) Detecting circuit is abnormal.

(25) “db” Project debugging

Error display: ODU mainboard, IDU displays

Error judgment condition and method: This is a status code of project debugging, not a error code.

When IDU or ODU displays this code, it means the unit is under debugging status and the IDU cannot be operated.

Troubleshooting: ——

Possible reason: ——

(26) “E1” high pressure protection

Error display: ODU mainboard, IDU displays

Applicable model: all models.

Error judgment condition and method: Judge through detecting the real-time high pressure or the high pressure switch. If the sensor detects that the high pressure value is over 65°C or the high pressure switch is disconnected, then it is judged as high pressure, the system will stop the unit for protection.

Possible reason:

- 1) Cut-off valve of ODU is not opened;
- 2) High pressure switch operation is abnormal;
- 3) Outdoor or indoor fan is abnormal;
- 4) Filter screen of IDU or air duct is blocked (heating mode);
- 5) Ambient operation temperature is too high;
- 6) Refrigerant charging of the system is too much;
- 7) System pipeline is blocked;

Troubleshooting:

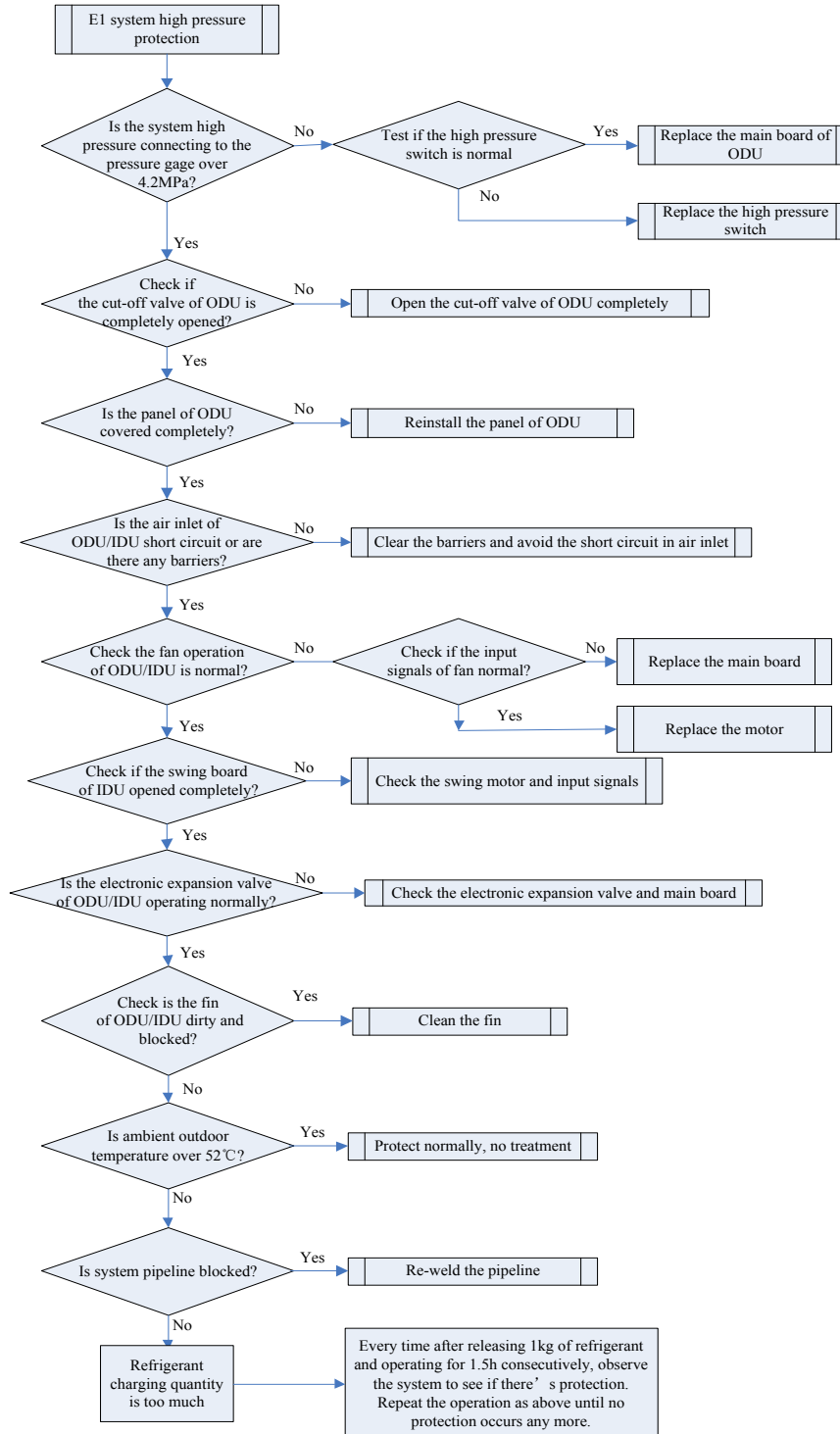

(27) “E3” system low pressure protection



Error display: ODU mainboard, IDU displays .

Applicable model: all models.

Error judgment condition and method: Detect the suction pressure of compressor through pressure sensor of low pressure, when the pressure value is below -41°C , the system will stop operation.

Possible reason:

- 1) Cut-off valve of ODU is not opened.

- 2) Low pressure sensor is abnormal.
- 3) Outdoor or indoor fan is abnormal.
- 4) Filter screen of IDU or air duct is blocked (cooling mode).
- 5) Ambient operation temperature is too low.
- 6) Insufficient refrigerant charging quantity.
- 7) System pipeline is blocked.

Troubleshooting:

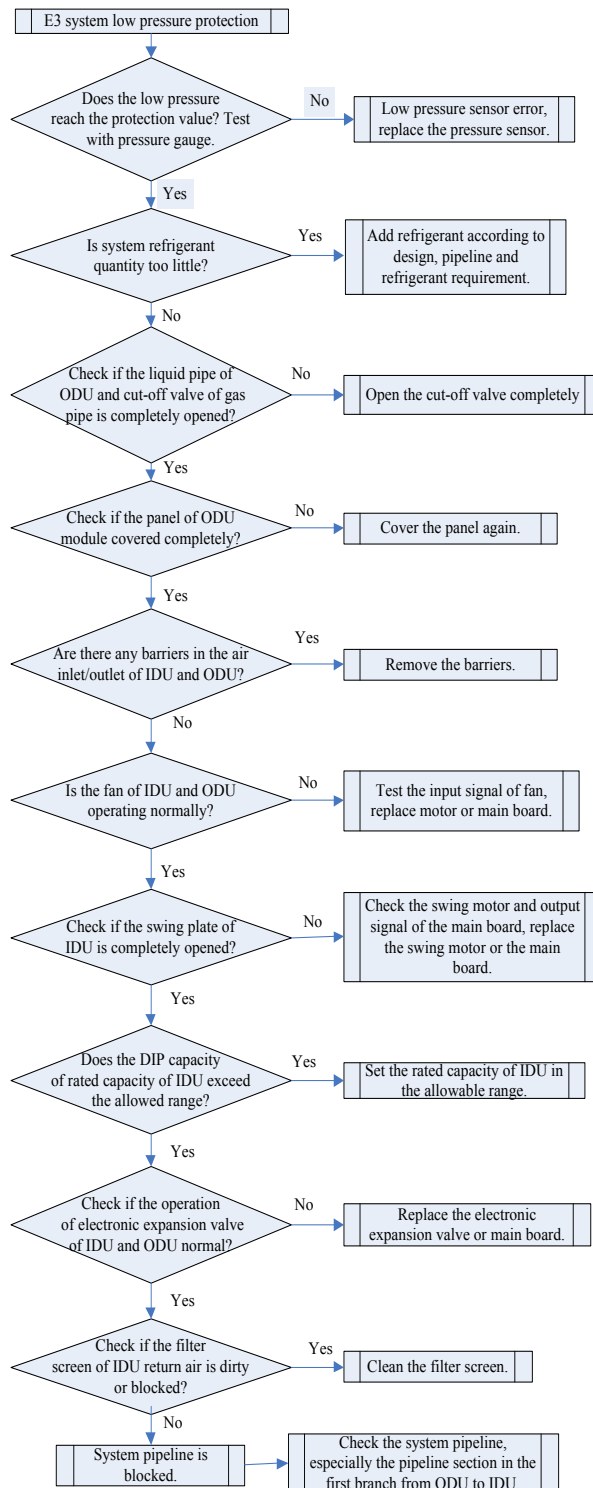

“E4” discharge high temperature protection for compressor

Error display: the main board of outdoor unit and indoor unit will display



Applicable model: all models.

Error judgment condition and method: Detect compressor discharge temperature through compressor exhaust pipe and the temperature sensor of shell, if the detection value is over 118°C, the

system will stop the unit for protection.

Possible reason:

- 1) Cut-off valve of ODU is not opened.
- 2) Operation of electronic expansion valve is abnormal.
- 3) Outdoor or indoor fan is abnormal.
- 4) Filter screen or air duct of IDU is blocked (cooling mode).
- 5) Ambient operation temperature exceeds the operation range.
- 6) Refrigerant charge is insufficient.
- 7) System pipeline is blocked.

Troubleshooting:

- 1) Step 1: Check and confirm the cut-off valve of ODU gas pipe and liquid pipe is completely opened;
- 2) Step 2: Restart the unit, after confirming the coil of IDU/ODU expansion valve is normally connected, disconnect the power and energize it to check the reset operation. If it is abnormal, replace the coil or main board; if it is normal, please check the other items;
- 3) Step 3: Restart the unit and observe if the fan of IDU/ODU is operating normally; if not, please replace motor or main board;
- 4) Step 4: If the protection is under cooling mode, please check if the filter screen of IDU is dirty, blocked or if the resistance of air duct is too big;
- 5) Step 5: Confirm that if the air return temperature of the unit exceeds the operation requirement (requirement for cooling mode: external temperature is $-5\sim 52^{\circ}\text{C}$ and internal temperature is $16\sim 32^{\circ}\text{C}$; requirement for heating mode: external temperature is $-20\sim 24^{\circ}\text{C}$ and internal temperature is $16\sim 30^{\circ}\text{C}$);
- 6) Step 6: Confirm if the refrigerant charge is added according to design requirement, insufficient refrigerant will cause protection;
- 7) Step 7: Restart the unit, confirm if the pipeline or expansion valve is blocked according to IDU/ODU parameter and cold/heat status of the pipeline (feel with hands).

(28) “F0” poor main board of outdoor unit

Error display: the main board of outdoor unit and indoor unit will display .

Applicable model: all outdoor units.

Error judgment condition and method: Check the reading of address chip, memory chip and clock chip of ODU main board is normal, if not, it can be judged as abnormal.

Possible reason:

- 1) The clock chip on the main board is damaged.
- 2) The memory chip on the main board is damaged.
- 3) The address chip on the main board is damaged.

Troubleshooting:

- 1) Replace the small CPU board.
- 2) Replace the control board.
- 3) Replace the control board.

(29) “F5” malfunction of discharge temperature sensor for compressor 1

Error display: the main board of outdoor unit and indoor unit will display .

Applicable model: all outdoor units.

Error judgment condition and method: Sample the AD value of temperature sensor through temperature sensor detecting circuit and judge the range of AD value, if the sampling AD value exceeds upper limit and lower limit in 30 seconds continuously, report the error.

Possible reason:

- 1) Poor contact between discharge temperature sensor and terminal in mainboard interface.
- 2) The discharge temperature sensor is abnormal.
- 3) The detected circuit is abnormal.

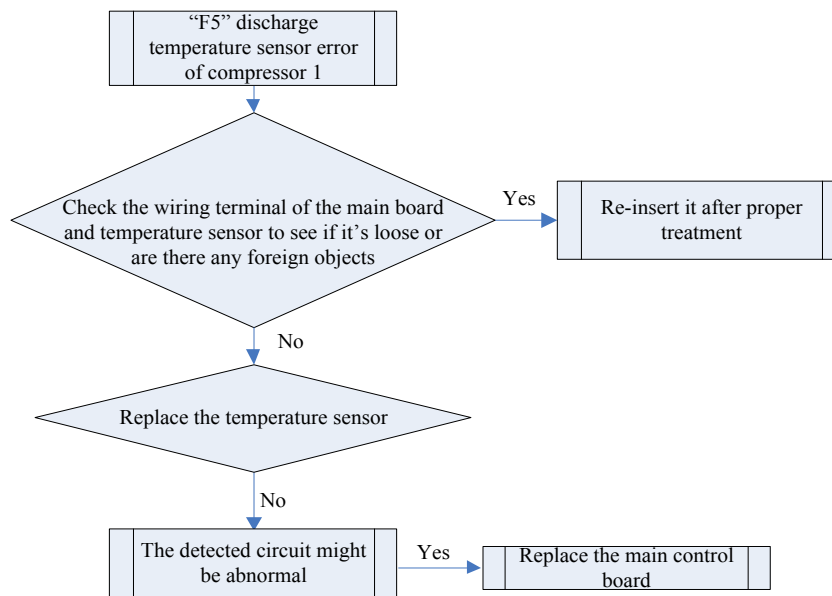
Troubleshooting:**(30) "J7" air-mixing protection for 4-way valve**

Error display: the main board of outdoor unit and indoor unit will display .

Applicable model: heat pump models.

Error judgment condition and method: Detect system high and low pressure through pressure sensor, start the unit, when the pressure difference of high and low pressure is less than 0.1MPa, the unit will be stopped for protection.

Possible reason:

- 1) Coil or connection wire is abnormal.
- 2) The main board is abnormal.
- 3) The internal of 4-way valve is abnormal.

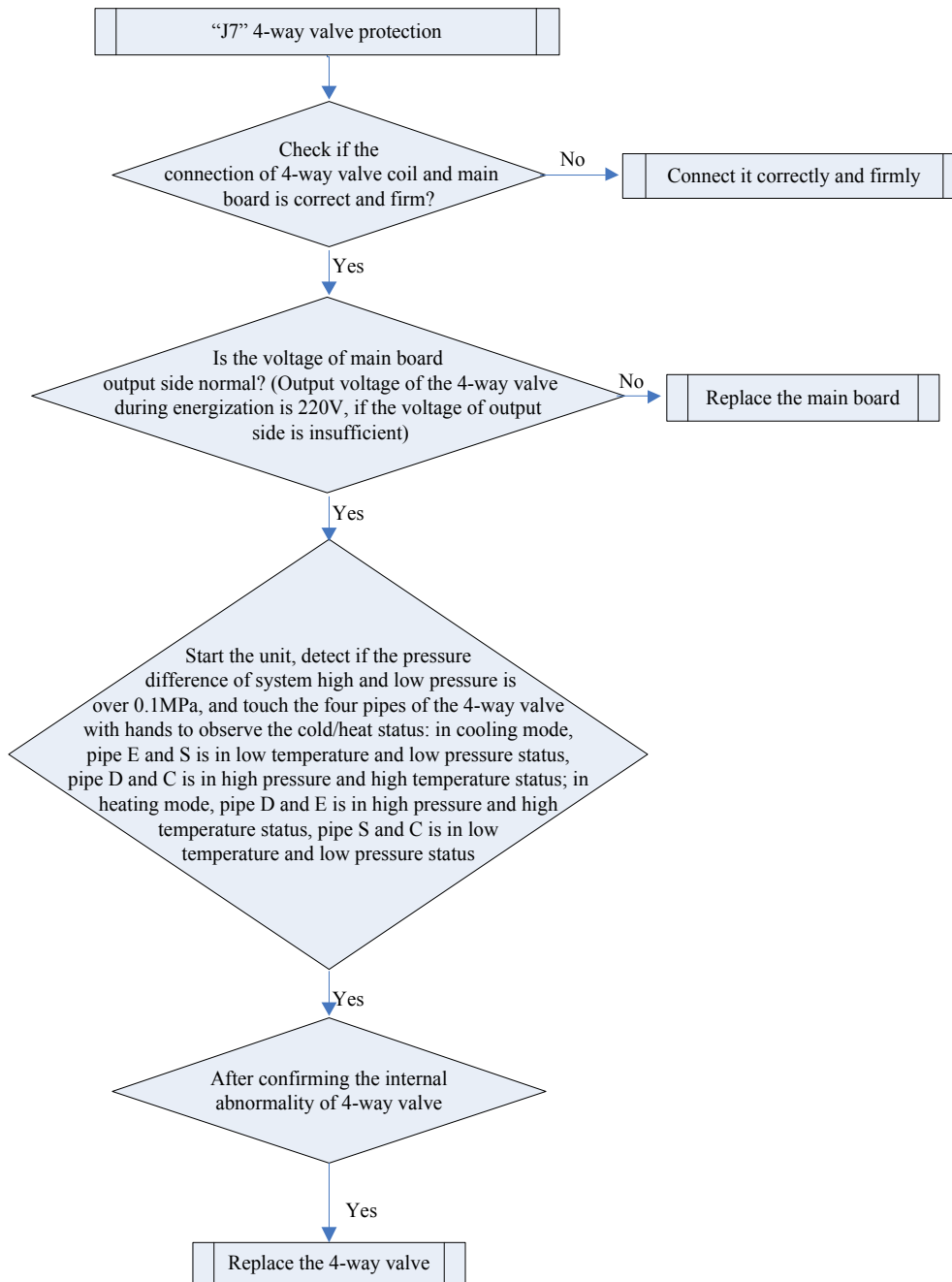
Troubleshooting:**(31) “L1” Indoor fan protection**

Error display: wired controller of IDU and the dash receiver of IDU will display

**Error judgment condition and method:**

Check if the rotation speed of IDU is too slow, or it stops rotation, or protection signal of outdoor fan is transferred. If yes, it is judged that indoor fan protection occurs.

Possible reason:

- 1) Motor stops operation or it is blocked.
- 2) IDU mainboard is abnormal.

(32) “L5” freeze protection

Error display: wired controller of IDU and the dash receiver of IDU will display

Error judgment condition and method:

Check IDU pipe temperature. When pipe temperature is too low, freeze protection will be activated to prevent freezing damage of evaporator.

Possible reason:

- 1) IDU filter and evaporator are dirty.
- 2) IDU motor is blocked.
- 3) Refrigerant amount is insufficient.
- 4) Ambient temperature of IDU and ODU is too low.

(33) “n0” energy conservation setting for operation

Error display: the main board of outdoor unit and indoor unit will display

Applicable model: all models.

Error judgment condition and method:

It is a code for function setting status, which means the system has entered energy conservation setting status. “00” means comfort shall take preferential control; “01” means energy conservation shall take preferential control; at this time, 15% of energy conservation can be achieved to the greatest extent.

Possible reason: ——

Troubleshooting: ——

(34) “n4” limit setting for the maximum output capacity

Error display: the main board of outdoor unit and indoor unit will display

Applicable model: all models.

Error judgment condition and method: It is a code for function setting status, which means the system has entered the highest limit setting for the maximum output capacity. “10” means the highest output capacity is 100%; “09” means the highest output capacity is 90%; “08” means the highest output capacity is 80%.

Possible reason: ——

Troubleshooting: ——

(35) “n6” malfunction inquiry

Error display: the main board of outdoor unit and indoor unit will display

Applicable model: all models.

Error judgment condition and method: It is a status inquiry code, which means the system has entered malfunction inquiry status. At this time, 5 historical malfunctions can be reviewed, please review the malfunctions of IDU and ODU separately.

Possible reason: ——

Troubleshooting: ——

(36) “n7” parameters inquiry



Error display: the main board of outdoor unit and indoor unit will display

Applicable model: all models.

Error judgment condition and method: It is a status inquiry code, which means the system has entered parameter inquiry status.

Possible reason: ——

Troubleshooting: ——

(37) “n8” engineering series number inquiry for indoor unit



Error display: wired controller of IDU will display

Applicable model: all models.

Error judgment condition and method: It is a status inquiry code, which means the system has entered parameter inquiry status. After entering this function, the wired controller will display the engineering code of the IDU, meanwhile, the buzzer of the IDU will give out a sound.

Possible reason: ——

Troubleshooting: ——

(38) “nA” quantity inquiry status of online IDU



Error display: the main board of ODU will display

Applicable model: all models.

Error judgment condition and method: It is a status inquiry code, at this time, the quantity of online IDU can be inquired.

Possible reason: ——

Troubleshooting: ——

(39) “nH” heating only model



Error display: ODU mainboard displays

Applicable model: all models.

Condition and method for fault judgement: The code represents the heating only status, which prompts that the system has been set as heating only status, the IDU can only conduct heating operation.

Possible cause: ——

Troubleshooting: ——

(40) “nC” cooling only model

Display: ODU mainboard displays

Applicable model: all models.

Condition and method for fault judgement:The code represents the cooling only status, which prompts that the system has been set as cooling only status, the IDU can only conduct cooling operation.

Possible cause: ——

Troubleshooting: ——

(41) “nE” negative code

Error display: ODU mainboard displays

Applicable model: all models.

Condition and method for fault judgement:The code is negative code that prompts the data displayed later is negative.

Possible cause: ——

Troubleshooting: ——

(42) “nF” fan model

Error display: ODU mainboard displays

Applicable model: all models.

Condition and method for fault judgement:The code represents fan status, which prompts that the system has been set as fan status, the IDU can only conduct fan mode operation.

Possible cause: ——

Troubleshooting: ——

(43) “P0” malfunction driven board for compressor

Error display: IDU wired controller displays

Applicable model: all models.

Condition and method for fault judgement:View the error code via IDU wired controller, if the IDU wired controller displays PO, then view the display of dual-8 nixie tube of main control board of ODU. According to the error code of main control board can estimate the the specific error of driven board of compressor, and then conduct troubleshooting by referring to specific troubleshooting methods.

Possible causes:

- 1) Reset protection for the driven module of compressor (dual-8 nixie tube of main control board of ODU displays P3).
- 2) Malfunction of driven temperature sensor for compressor (dual-8 nixie tube of main control board of ODU displays P7).
- 3) Overheating protection for driven IPM of compressor (dual-8 nixie tube of main control).
- 4) Circuit malfunction of driven current detection for compressor (dual-8 nixie tube of main

- control board of ODU displays PC).
- 5) Malfunction of driven charging loop for compressor (dual-8 nixie tube of main control board of ODU displays PF).
 - 6) Desynchronizing protection for inverter compressor (dual-8 nixie tube of main control board of ODU displays P9).
 - 7) Failure startup for inverter compressor (dual-8 nixie tube of main control board of ODU displays PJ).

Troubleshooting: Find corresponding solution according to the error code displayed in the mainboard of ODU.

(44) “P2” power voltage protection for the driven board of compressor



Error display: IDU wired controller displays

Applicable model: all models.

Condition and method for fault judgement: View the error code via IDU wired controller, if the IDU wired controller displays P2, then view the display of dual-8 nixie tube of main control board of ODU. According to the error code of main control board can estimate the the specific error of driven board of compressor, and then conduct troubleshooting by referring to specific troubleshooting methods.

Possible causes:

- 1) High voltage protection for driven DC bus bar of compressor (dual-8 nixie tube of main control board of ODU displays PH).
- 2) Low voltage protection for driven DC bus bar of compressor (dual-8 nixie tube of main control board of ODU displays PL).

Troubleshooting: Find corresponding solution according to the error code displayed in the mainboard of ODU.

(45) “P3” reset protection for the driven module of compressor



Error display: ODU mainboard displays

Applicable model: all models.

Condition and method for fault judgement: View the error code displayed in dual-8 nixie tube of main control board of ODU, if the nixie tube displays P3, it means reset protection for the driven module of compressor.

Possible cause:

- 1) Compressor driver board error.

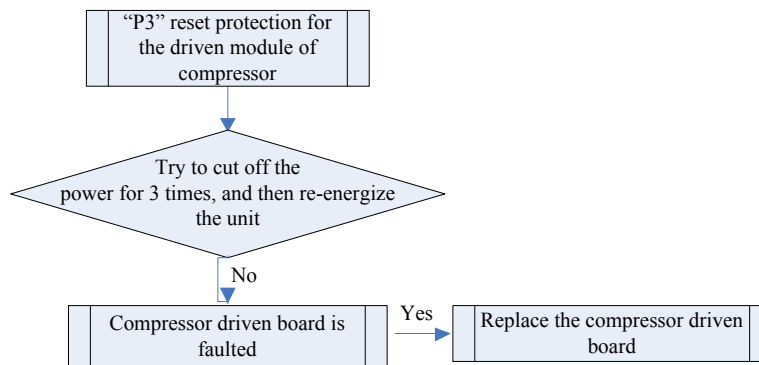
Troubleshooting:**(46) "P5" overcurrent protection for inverter compressor**

Error display: ODU mainboard displays .

Applicable model: all models.

Condition and method for fault judgement: View the error code displayed in dual-8 nixie tube of main control board of ODU, if the nixie tube displays P5, it means overcurrent protection for inverter compressor.

Possible cause:

- 1) Poor contact of compressor UVW wires.
- 2) Incorrect connecting order of compressor UVW wires.
- 3) Compresso is damaged.
- 4) The system is blocked.
- 5) IPM module of compressor driven board is damaged.

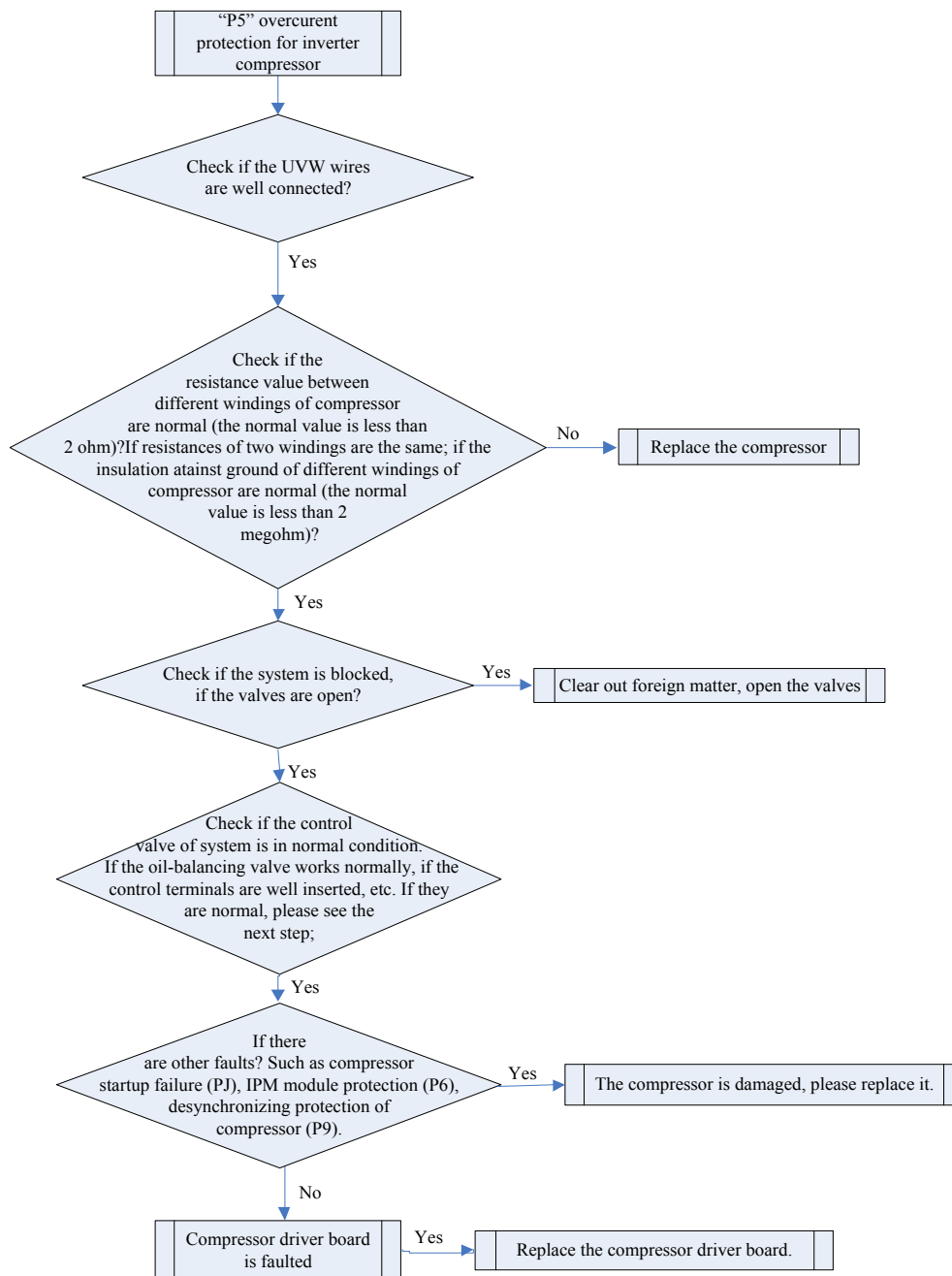
Troubleshooting:**(47) “P6” driven IPM module protection for compressor**

Error display: ODU mainboard displays .

Applicable model: all models.

Condition and method for fault judgement: View the error code displayed in dual-8 nixie tube of main control board of ODU, if the nixie tube displays P6, it means driven IPM module protection for compressor.

Possible causes:

- 1) Poor contact of compressor UVW wires.
- 2) Incorrect connecting order of compressor UVW wires.

- 3) Compresso is damaged.
- 4) The system is blocked.
- 5) IPM module of compressor driven board is damaged.

(48) “P7” malfunction of driven temperature sensor for compressor



Error display: ODU mainboard displays

Applicable model: all models.

Condition and method for fault judgement:View the error code displayed in dual-8 nixie tube of main control board of ODU, if the nixie tube displays P7, it means malfunction of driven temperature sensor of compressor.

Possible cause:

- 1) Driven board of compressor is faulted.

Troubleshooting:

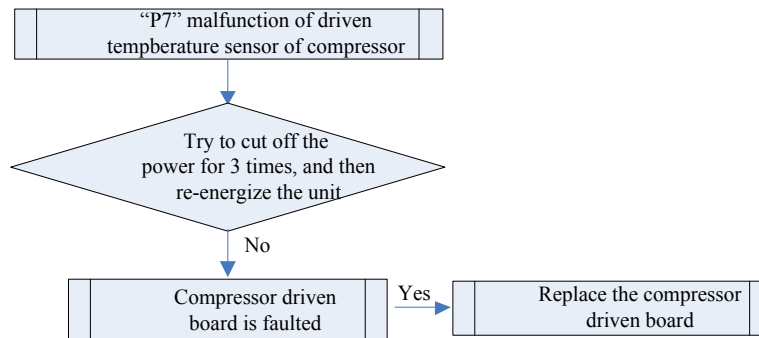

(49) “P8” overheating protection for driven IPM of compressor



Error display: ODU mainboard displays

Applicable model: all models.

Condition and method for fault judgement:View the error code displayed in dual-8 nixie tube of main control board of ODU, if the nixie tube displays P8, it means overheating protection for driven IPM of compressor.

Possible cause:

- 1) Screws for IPM module has not been firmly fixed.
- 2) No radiating paste in the IPM module, uneven application of radiating paste or the radiating paste is dry.
- 3) The driven board od compressor is faulted.

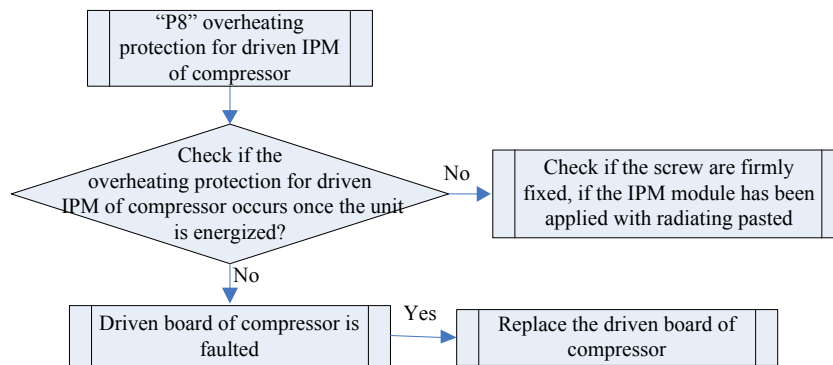
Troubleshooting:**(50) "P9" desynchronizing protection for inverter compressor**

Error display: ODU mainboard displays .

Applicable model: all models.

Condition and method for fault judgement: View the error code displayed in dual-8 nixie tube of main control board of ODU, if the nixie tube displays P9, it means desynchronizing protection for inverter compressor.

Possible causes:

- 1) Driven board of compressor is faulted.
- 2) Compressor is damaged.

Troubleshooting:

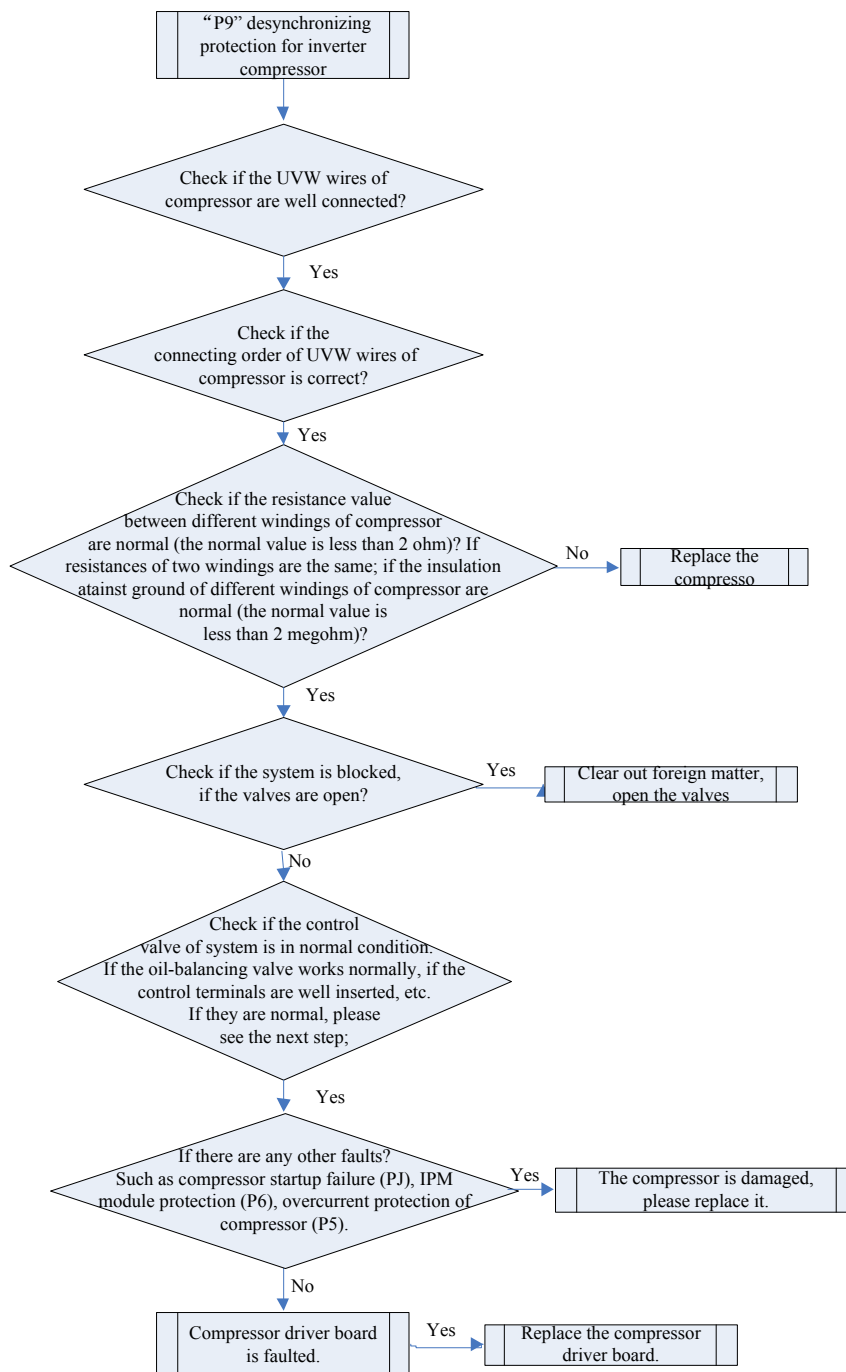

(51) “PC” circuit malfunction of driven current detection for compressor



Error display: ODU mainboard displays .

Applicable model: all models.

Condition and method for fault judgement: View the error code displayed in dual-8 nixie tube of main control board of ODU, if the nixie tube displays PC, it means circuit malfunction of driven current detection for compressor.

Possible cause:

- 1) Driven board of compressor is faulted.

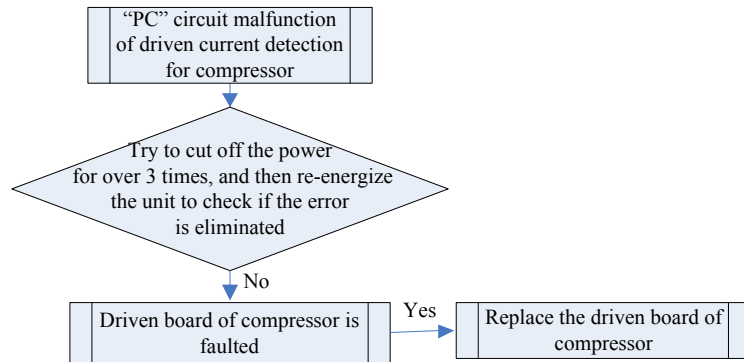
Troubleshooting:**(52) "PH" high voltage protection for driven DC bus bar of compressor**

Error display: ODU mainboard displays .

Applicable model: all models.

Condition and method for fault judgement: Check if the voltage of input power cord for mainboard is over 460V, if yes, the protection occurs.

Possible causes:

- 1) Voltage of input power cord is over 460V.
- 2) Driven board of compressor is faulted.

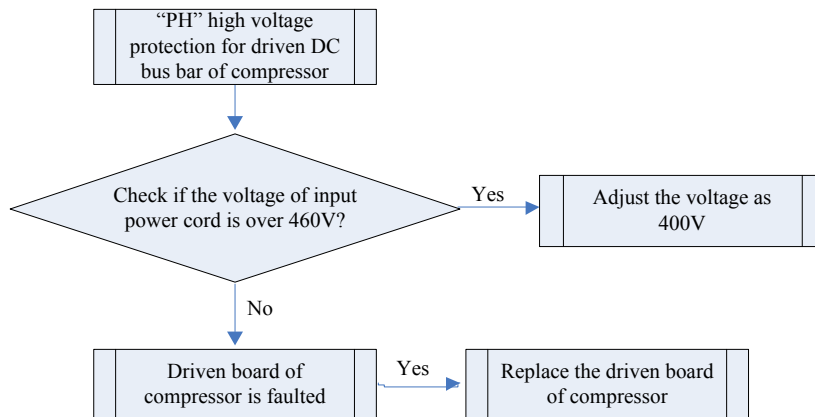
Troubleshooting:**(53) "PL" low voltage protection for driven DC bus bar of compressor**

Error display: ODU mainboard displays .

Applicable model: all models.

Condition and method for fault judgement: Check if the voltage of input power cord for mainboard is less than 320V, if yes, the protection occurs.

Possible causes:

- 1) Voltage of input power cord is less than 320V.
- 2) Driven board of compressor is faulted.

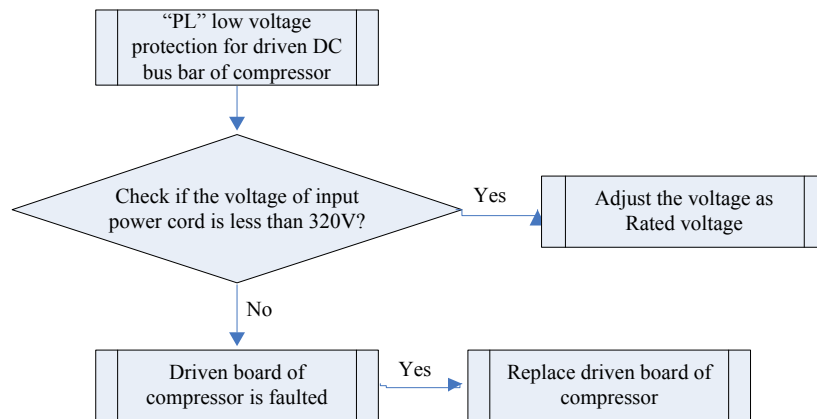
Troubleshooting:**(54) "PJ" failure startup for inverter compressor**

Error display: ODU mainboard displays .

Applicable model: all models.

Condition and method for fault judgement: View the error code displayed in dual-8 nixie tube of main control board of ODU, if the nixie tube displays PJ, it means failure startup for inverter compressor.

Possible causes:

- 1) Poor contact of compressor UVW wires.
- 2) Compressor is damaged.
- 3) Driven board of compressor is faulted.

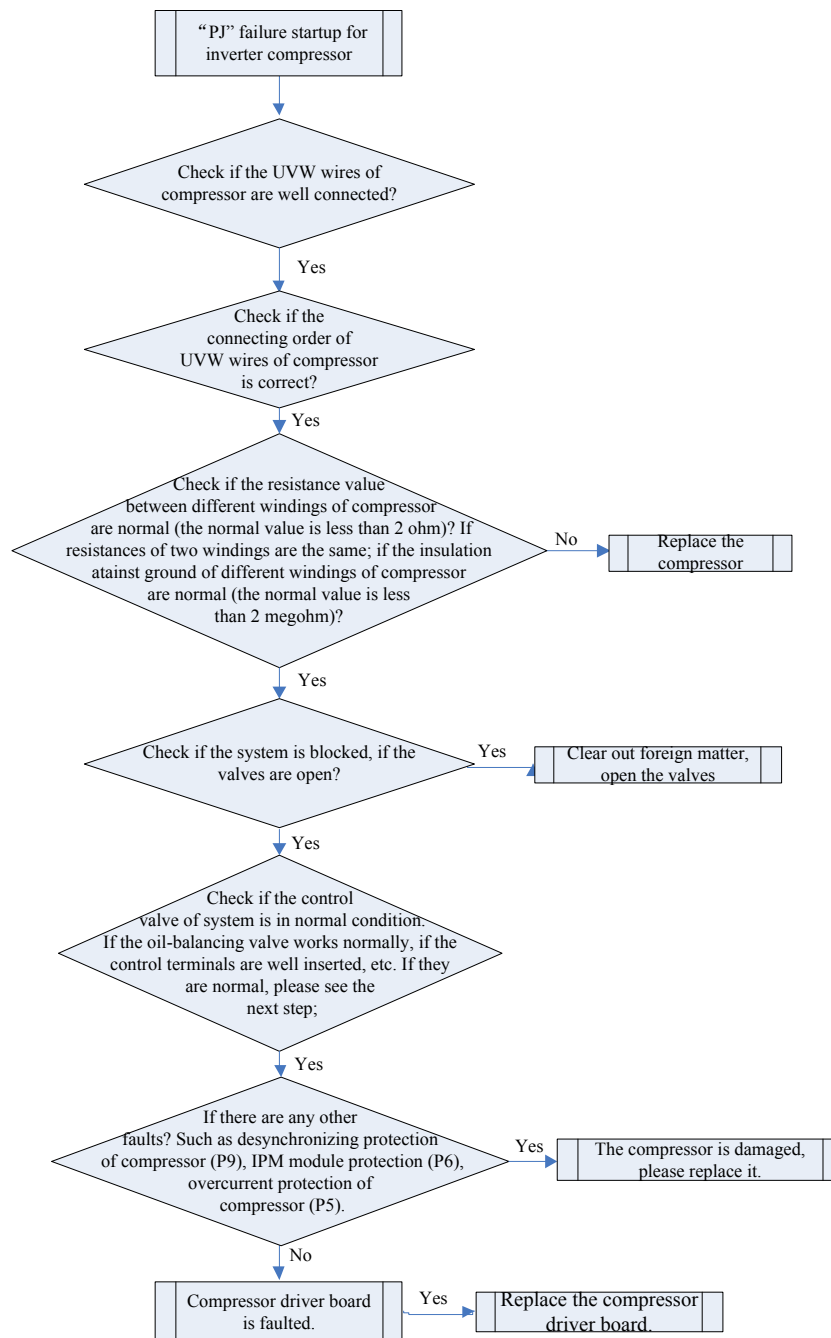
Troubleshooting:**(55) “U0” insufficient preheat time for compressor**

Error display:ODU mainboard and IDU display

Applicable model: all models.

Condition and method for fault judgement:Check the preheat time of oil temperature before startup of compressor, if it is less than 8 hours, it will report the error.

Possible cause: —

Troubleshooting:

Preheat the unit for over 8 hours before startup.

(56) “U2” wrong setting of capacity dial code/jumper cap of outdoor unit

Error display: ODU mainboard and IDU display .

Applicable model: all ODUs.

Condition and method for fault judgement: Inconsistency between the capacity dial code detected by ODU mainboard and actual capacity of unit. Inconsistency between the jumper cap value detected by ODU mainboard and actual jumper cap value of unit.

Possible causes:

- 1) Wrong capacity dial code or wrong jumper cap (some models are without jumper cap).
- 2) Dial code switch or jumper cap is damaged.
- 3) Detecting circuit is faulted.

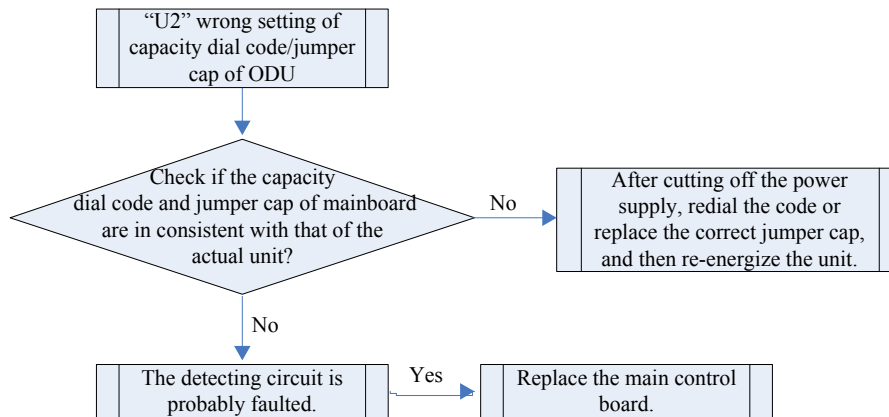
Troubleshooting:**(57) “U6” alarm due to abnormal valve**

Error display: ODU mainboard and IDU display .

Applicable model: all models.

Condition and method for fault judgement: During debugging, detect the system parameters via pressure sensor to estimate if the the cut-off valve of ODU is open; if the parameters are abnormal, it will prompt to check to open the cut-off valve again, after it is checked, press SW5 to enter to the next step.

Possible cause:

- 1) Cut-off vale of ODU is not opened.

Troubleshooting:

- 1) Recheck and open the cut-off valve of ODU.

(58) Setting for indoor unit and outdoor unit is succeeded

Error display: ODU mainboard and IDU display .

Applicable model: all models.

Condition and method for fault judgement: The code refers to quantity of state instead of error.

During the debugging, it means the master IDU has been successively set.

Possible cause: ——

Troubleshooting: ——

(59) Poor cooling/heating effect

Applicable model: all IDUs.

Condition and method for fault judgement:

- 1) When IDU operates under cooling mode, and the electronic expansion valve opens to 480PLS, tube outlet temperature of IDU coil is 5 °C or above over than tube inlet temperature.
- 2) When IDU operates under heating mode, and the electronic expansion valve opens to 480PLS, tube inlet temperature of IDU coil is 12 °C or above less than corresponding saturation temperature of high pressure.

Possible causes:

- 1) Cut-off valve of ODU has not been opened to the greatest flow position as required.
- 2) The system pipeline is blocked.
- 3) Operating environment condition exceeds the applicable range.
- 4) Poor design of air flow organization.
- 5) Insufficient charging volume of refrigerant.

Troubleshooting:

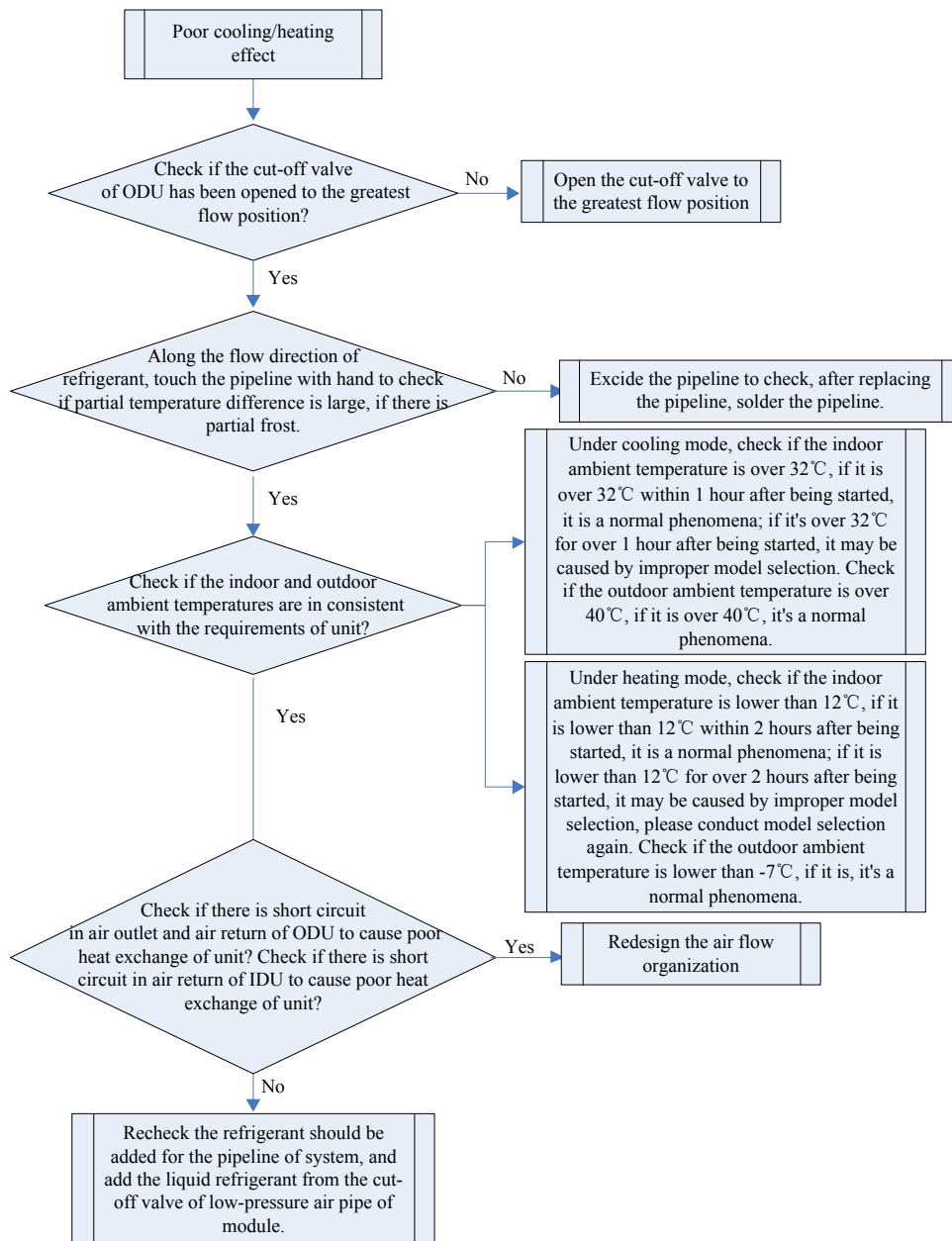

3 Wiring Diagram

Advertence: These diagrams only for reference ,the actually diagram please reference the diagram on actually unit.

FGR20Pd/DNa-X(I)/FGR25Pd/DNa-X(I)/FGR30Pd/DNa-X(I):

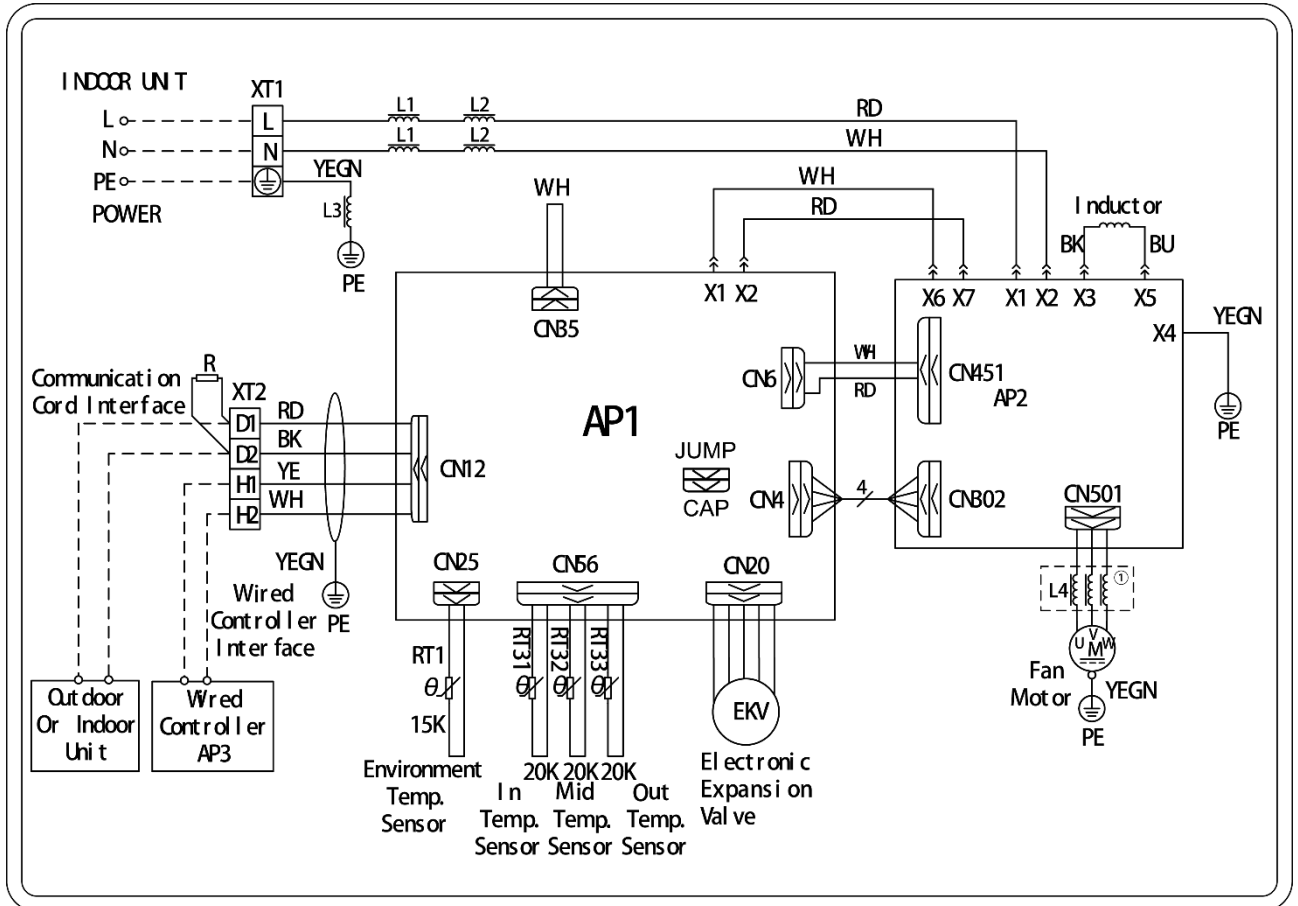

FGR25Pd/DNa-X(O):

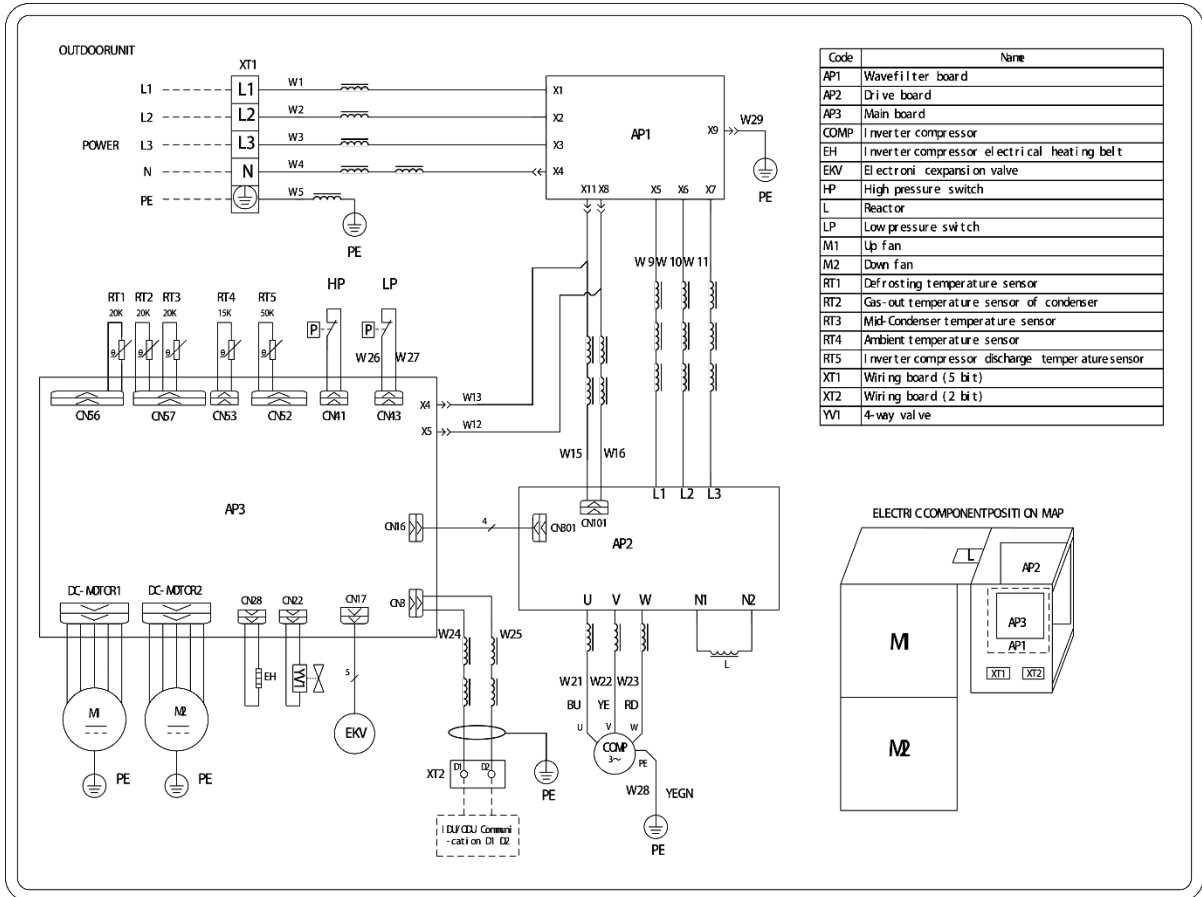

FGR30Pd/DNa-X(O):

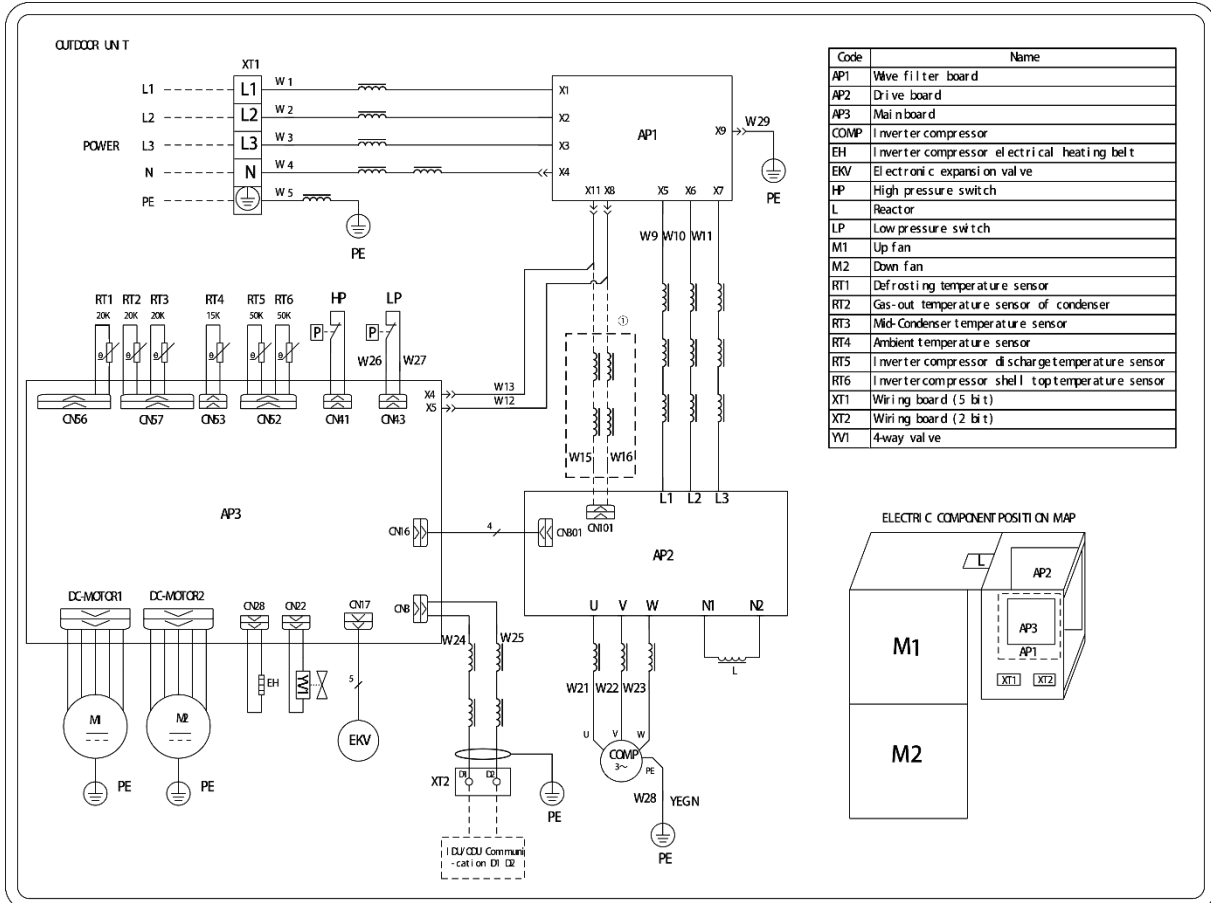

4 Disassembly And Assembly Procedure Of Main Parts

Introduction to Main Parts.

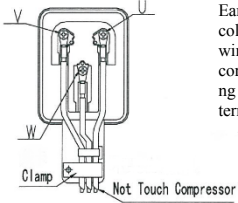
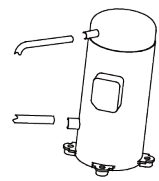
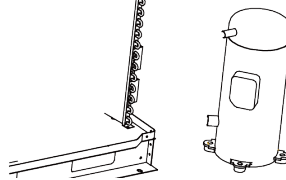
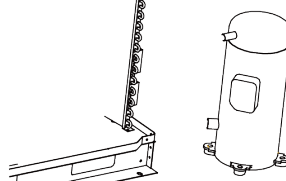
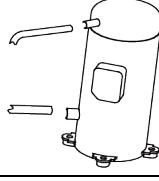
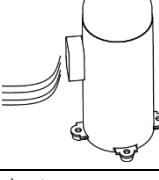
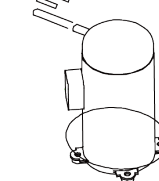
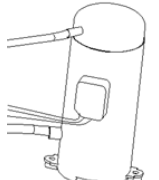
| Disassembly and Assembly of Compressor | | |
|--|---|--|
| Remark: Make sure that there isn't any refrigerant in pipe system and the power supply is cut off before removal of the compressor | | |
| Step | Illustration | Handling Instruction |
| 1. Disconnect the power cord |  <p>Earmark the colour of wire corresponding to the terminal</p> | <p>① Unscrew the retaining screw of power cord with screwdriver.</p> <p>② Unplug the power cord.</p> <p>Note: Earmark the colour of wire corresponding to the terminal when Removing the wire, and the mixture can be avoided when recovering the wire connection.</p> |
| 2. Cut off the connection between compressor and pipes |  | Don't leave the welding slag inside pipes |
| 3. Remove the compressor from the chassis |  | <p>① Unscrew retaining nuts of the footing of compressor</p> <p>② Remove the compressor from the chassis</p> <p>Hold it tightly to avoid accident.</p> |
| 4. Fix the new compressor on chassis |  | <p>① Place the new compressor on chassis</p> <p>② Fix retaining nuts of compressor footing.</p> |
| 5. Connect the compressor with system pipes |  | Don't block it by welding. |
| 6. Connect the power cord of compressor |  | Note: Earmark the colour of wire corresponding to the terminal when connecting the wire, and the mixture can be avoided |
| 7. Recover the electric heating tape of compressor and discharge temperature sensor, etc. |  | Enwind the bottom of compressor with electric heating tape and fix it. |
| 8. Check if the compressor rotates in reverse and if lubricant have leaked |  | Check if the wiring is correct with reference to circuit diagram and check if there is any leakage after welding. |

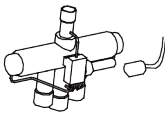
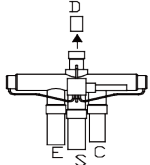
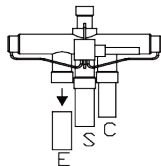
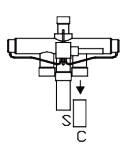
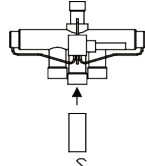
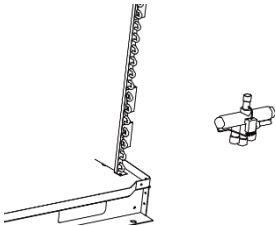
| Disassembly and Assembly of 4-way valve | | |
|--|---|--|
| Remark: Make sure that there isn't any refrigerant in pipe system and the power supply is cut off before removal of 4-way valve. | | |
| Step | Illustration | Handling Instruction |
| Remove electric coils of 4- way valve |  | Place electric coils far away from the 4-way valve to prevent the connecting line of 4-way valve from burning when succeeding welding. |
| Disconnect the pipe (site D in illustration) of 4-way valve and discharge pipe |  | Don't leave welding slag inside pipes. |
| Disconnect the pipe (site E in illustration) of 4-way valve and connecting pipe |  | Don't leave welding slag inside pipes. |
| Disconnect the pipe (site C in illustration) of 4-valve and connecting pipe |  | Don't leave welding slag inside pipes. |
| Disconnect the pipe (site S in illustration) of 4-way valve and connecting pipe |  | Don't leave welding slag inside pipes. |
| Remove the 4-way valve |  | Remove 4-way valve after it is cooled. |
| Install new 4-way valve in reversed order and wrap it with wet cloth before welding. | | |

5 Exploded Views And Part List

5.1 Indoor Unit

Model: FGR20Pd/DNa-X(I)、FGR25Pd/DNa-X(I)、FGR30Pd/DNa-X(I)

Exploded View:

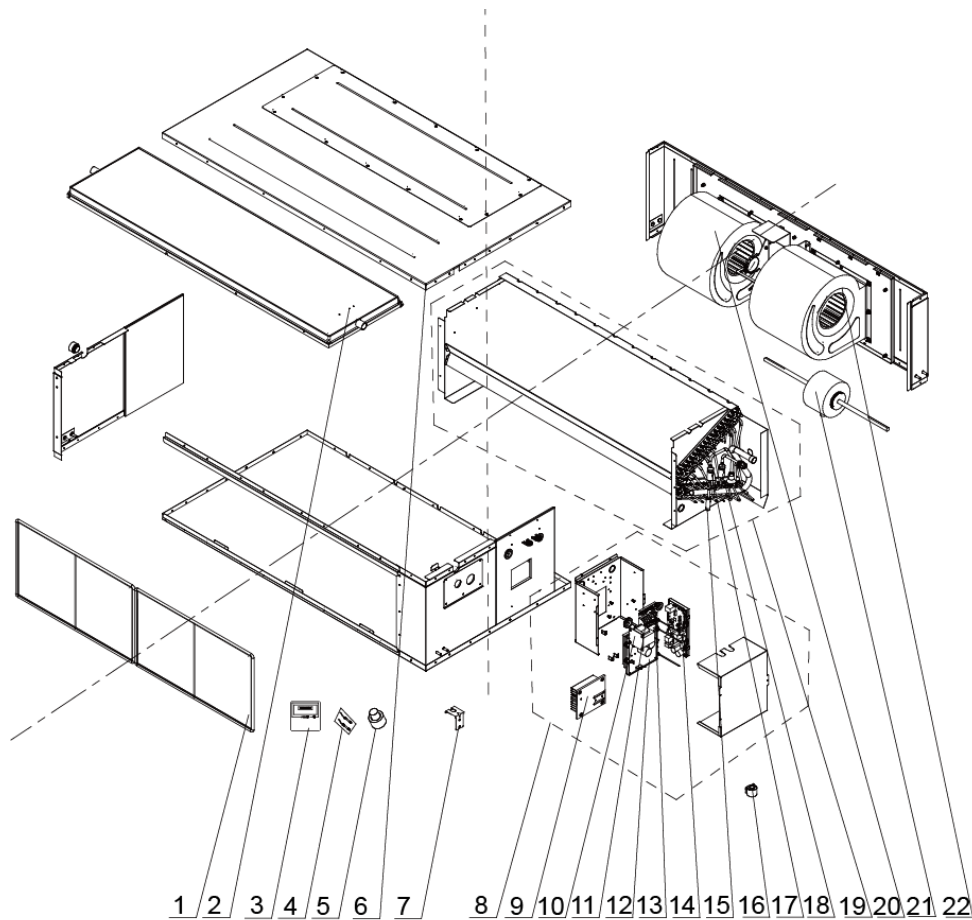

| NO | Model | FGR20Pd/DNa-X(I) | FGR25Pd/DNa-X(I) | FGR30Pd/DNa-X(I) | Qty |
|----|----------------------------|------------------|------------------|------------------|-----|
| | Product Code | CF010N0730 | CF010N0740 | CF010N0750 | |
| | Part Name | Part Code | Part Code | Part Code | |
| | 1 | Filter Sub-Assy | 11725211 | 11724102 | |
| 2 | Water Tray Assy | 01284620 | 01284306 | 01284306 | 1 |
| 3 | Display Board | 300001000097 | 300001000097 | 300001000097 | 1 |
| 4 | Sensor Sub-assy | 390002000058 | 390002000058 | 390002000058 | 1 |
| 5 | Choke Plug of Water Pipe | 76712454 | 76712454 | 76712454 | 2 |
| 6 | Top Cover Board Sub-assy | 01265359 | 01264100090 | 017011000037 | 1 |
| 7 | Hook | 02112466 | 02112466 | 02112466 | 4 |
| 8 | Electric Box Assy | 100002002010 | 100002002010 | 100002002010 | 1 |
| 9 | Radiator | 49018000068 | 49018000068 | 49018000068 | 1 |
| 10 | Reactor | 43130189 | 43130189 | 43130189 | 1 |
| 11 | Terminal Board | 4201800002601 | 4201800002601 | 4201800002601 | 1 |
| 12 | Main Board | 300002000383 | 300002000383 | 300002000383 | 1 |
| 13 | Terminal Board | 42010259 | 42010259 | 42010259 | 1 |
| 14 | Main Board | 300002000357 | 300002000357 | 300002000357 | 1 |
| 15 | Electronic Expansion Valve | 43044100190 | 43044100190 | 43044100190 | 1 |

| NO | Model | FGR20Pd/DNa-X(l) | FGR25Pd/DNa-X(l) | FGR30Pd/DNa-X(l) | Qty |
|----|---------------------------------------|------------------|------------------|--------------------|-----|
| | Product Code | CF010N0730 | CF010N0740 | CF010N0750 | |
| | Part Name | Part Code | Part Code | Part Code | |
| 16 | Electric Expand Valve Fitting | 4304413205 | 4304413205 | 4304413205 | 1 |
| 17 | Strainer | 074141000601 | 074141000601 | 074141000601 | 2 |
| 18 | Evaporator Assy | 011001000372 | 011001000371 | 011001000271 | 1 |
| 19 | Motor for Centrifugal Fan(Right Type) | 15705307 | 1570411801 | 1030040000470 1 | 1 |
| 20 | Brushless DC Motor | 15704100009 | 15704100009 | 15704100009 | 1 |
| 21 | Motor for Centrifugal Fan(Left Type) | 15705306 | 15704118 | 103004000047 | 1 |

Model: FGR40Pd/D(2)Na-X(l)

Exploded View:

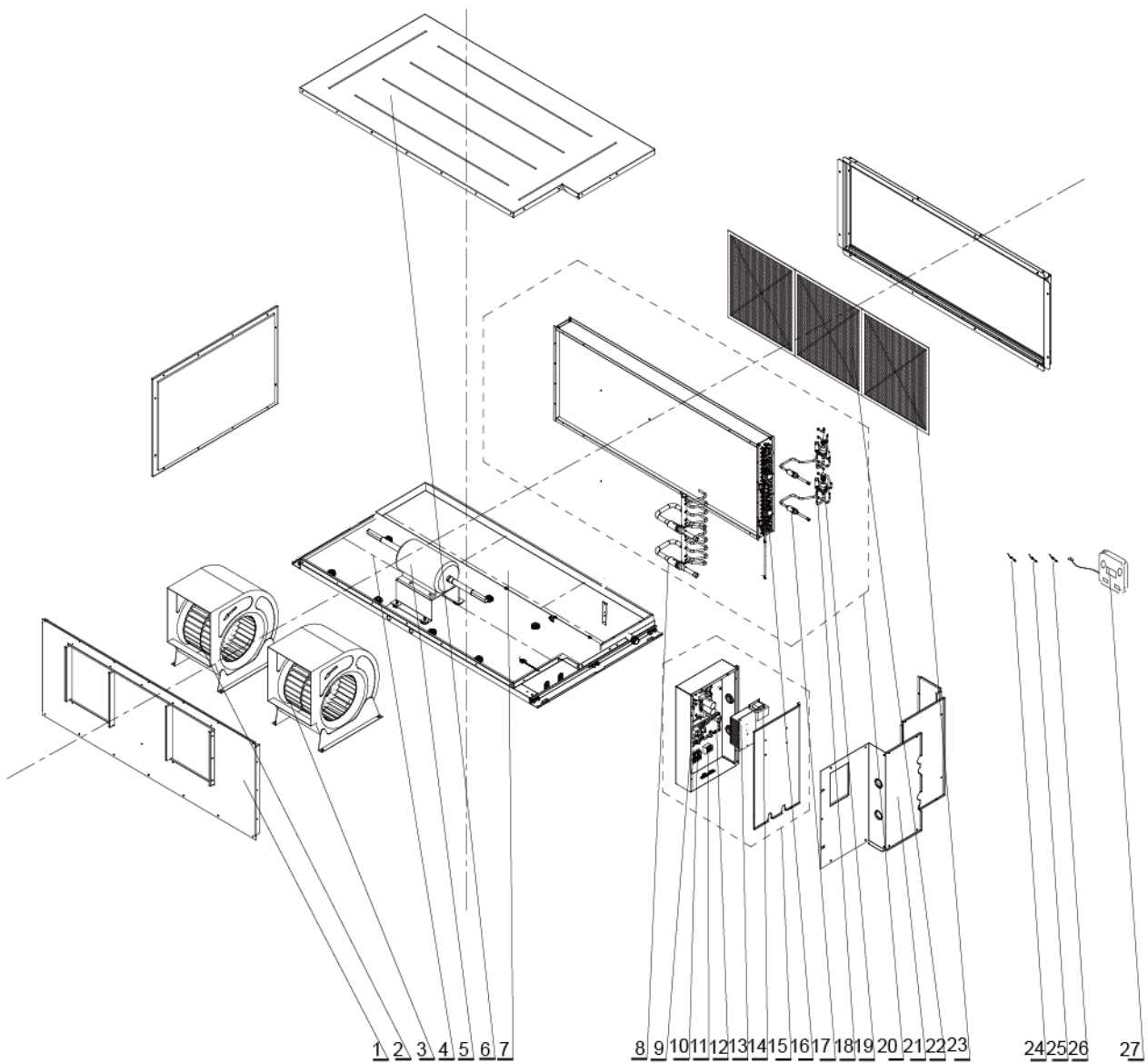

| NO | Model | FGR40Pd/D(2)Na-X(l) | Qty |
|----|-------------------------------|---------------------------------|-----|
| | Product Code | CF010N0760 | |
| | Part Name | Part Code | |
| 1 | Air Outlet Panel Sub-assy | 000040000029 | 1 |
| 2 | Motor for Centrifugal Fan | 103004000048/ 10300400004801 | 1/1 |
| 3 | Left Side Plate Assy | 000080000020 | 1 |
| 4 | Hange frame assy | 000249000001 | 1 |
| 5 | Brushless DC Motor | 150104000015 | 1 |
| 6 | Top Cover Board Sub-assy | 017011000039 | 1 |
| 7 | Water Collecting Tray Assy | 007070000002 | 1 |
| 8 | Strainer | 07210037 | 1 |
| 9 | Main Board | 300002000357 | 1 |
| 10 | Terminal Board | 420001000004 | 1 |
| 11 | Terminal Board | 4201800002601 | 1 |
| 12 | Main Board | 300002000380 | 1 |
| 13 | Radiator | 49018000013 | 1 |
| 14 | Reactor | 43130189 | 1 |
| 15 | Electric Expand Valve Fitting | 4304413205 | 2 |
| 16 | Electric Box Assy | 100002001945 | 1 |
| 17 | Strainer | 0741410000601 | 2 |
| 18 | Electronic Expansion Valve | 43044100190 | 2 |
| 19 | Strainer | 07415210 | 2 |
| 20 | Evaporator Assy | 011001000429 | 1 |
| 21 | Access panel sub-assy | 000170000001 | 1 |
| 22 | Filter Sub-Assy | 07210029 | 1 |
| 23 | Temperature Sensor | 3900028024G | 1 |
| 24 | Temperature Sensor | 3900028022G | 1 |
| 25 | Ambient Temperature Sensor | 39000198G | 1 |

5.2 Outdoor Unit

Model:FGR20Pd/DNa-X(O)、FGR25Pd/DNa-X(O)

Exploded View:

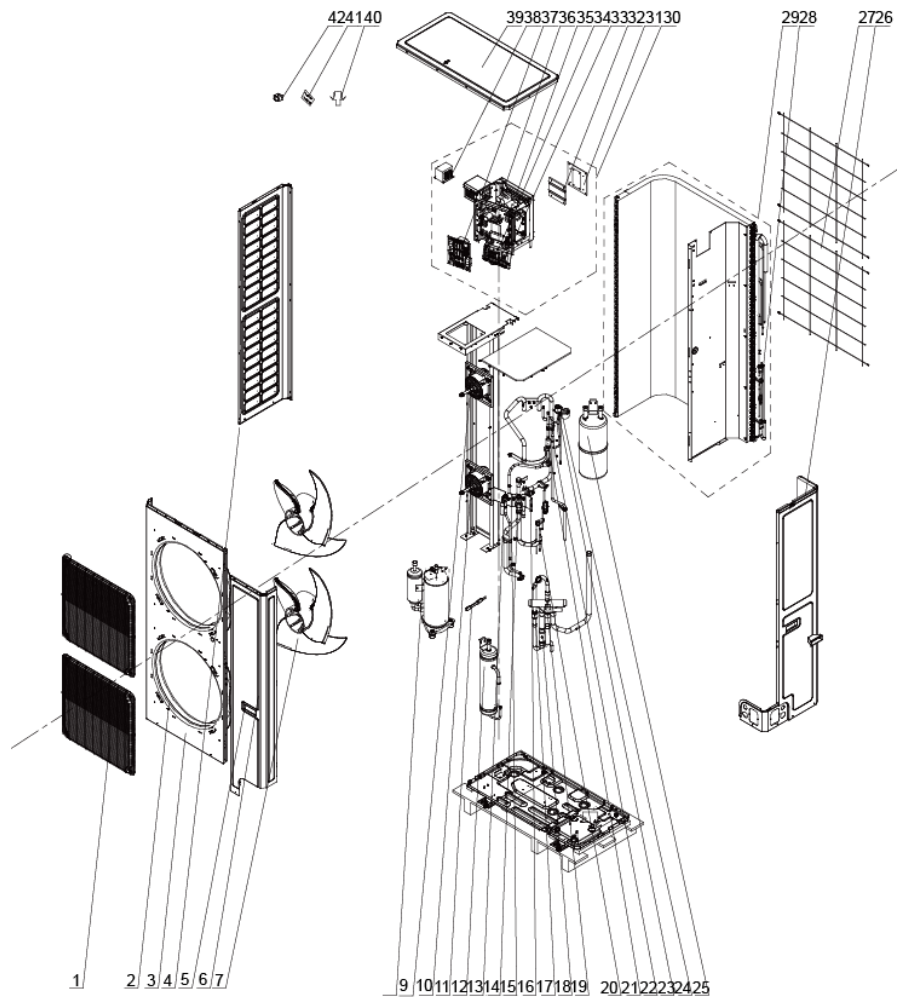

| NO. | Model | FGR20Pd/DNa-X(O) | FGR25Pd/DNa-X(O) | Qty |
|-----|-------------------------------|---------------------------------|-------------------------------|-----|
| | Product Code | CF010W0730 | CF010W0740 | |
| | Part Name | Part Code | Part Code | |
| 1 | Front Grill | 01572800003 | 01572800003 | 2 |
| 2 | Diversion Circle | 10474100003 | 10474100003 | 2 |
| 3 | Cabinet Assy | 01514100015 | 01514100023 | 1 |
| 4 | Left Side Plate | 01314100084P | 01314100090P | 1 |
| 5 | Handle | \ | 26235253 | 1 |
| 6 | Front Side Plate | 01314100082P | 01314100091P | 1 |
| 7 | Axial Flow Fan | 10434100006 | 10434100008 | 2 |
| 8 | Compressor and Fittings | 00204100013 | 00204100033 | 1 |
| 9 | Brushless DC Motor | 1570280000401\ 1570280000402 | 15704100010/ 1570410001001 | 1/1 |
| 10 | Motor Support Assy | 00004600007 | 000046000057 | 1 |
| 11 | Electrical Heater(Compressor) | 7651521212 | 7651521212 | 1 |
| 12 | Oil Separator | 07424105 | 07424100050 | 1 |
| 13 | Cut off Valve | 07334100011 | 07334100011 | 1 |
| 14 | Cut off valve | 07334100054 | 07334100012 | 1 |

| NO. | Model | FGR20Pd/DNa-X(O) | FGR25Pd/DNa-X(O) | Qty |
|-----|-------------------------------|------------------|------------------|-----|
| | Product Code | CF010W0730 | CF010W0740 | |
| | Part Name | Part Code | Part Code | |
| 15 | Pressure Protect Switch | 4602000902 | 4602000902 | 1 |
| 16 | Pressure Protect Switch | 46020007 | 46020007 | 1 |
| 17 | One Way Valve | 07334100075 | 07335210 | 1 |
| 18 | Strainer | 07212402 | 07414100026 | 1 |
| 19 | 4-way Valve | 43000338 | 43000339 | 1 |
| 20 | Strainer | 07212403 | 07415200002 | 1 |
| 21 | Bidirection Strainer | / | 07220016 | 1 |
| 22 | One Way Valve | 07133618 | 04324001 | 1 |
| 23 | Electronic Expansion Valve | 43044100173 | 43044100173 | 1 |
| 24 | Electric Expand Valve Fitting | 4304413219 | 4304413205 | 1 |
| 25 | Gas-liquid Separator | 07424140 | 07424141 | 1 |
| 26 | Rear Side Plate | 01314100083P | 01314100092P | 1 |
| 27 | Rear Grill | 01574100011 | 01574100014 | 1 |
| 28 | Strainer | 07212403 | 07212121 | 1 |
| 29 | Condenser Assy | 000100000042 | 000100000059 | 1 |
| 30 | Electric Box Assy | 100002001182 | 100002001106 | 1 |
| 31 | Radiator | 430034000028 | 49018000080 | 1 |
| 32 | Radiator | 430034000027 | 49018000088 | 1 |
| 33 | Terminal board | 420001000019 | 420001000019 | 1 |
| 34 | Terminal board | 42011221 | 42011221 | 1 |
| 35 | Main Board | 300027000340 | 300027000392 | 1 |
| 36 | Main Board | 300027000244 | 300027000244 | 1 |
| 37 | Filter Board | 30223000118 | 30228000015 | 1 |
| 38 | Reactor | 4313017401 | 4313017401 | 1 |
| 39 | Coping | 01264100047P | 01264100052P | 1 |
| 40 | Drainage Joint | 26113009 | 26113009 | 1 |
| 41 | Sensor Sub-assy | 390002000046 | 390002000046 | 1 |
| 42 | Magnet Coil | 4300040032 | 4300040032 | 1 |

Model: FGR30Pd/DNa-X(O)

Exploded View:

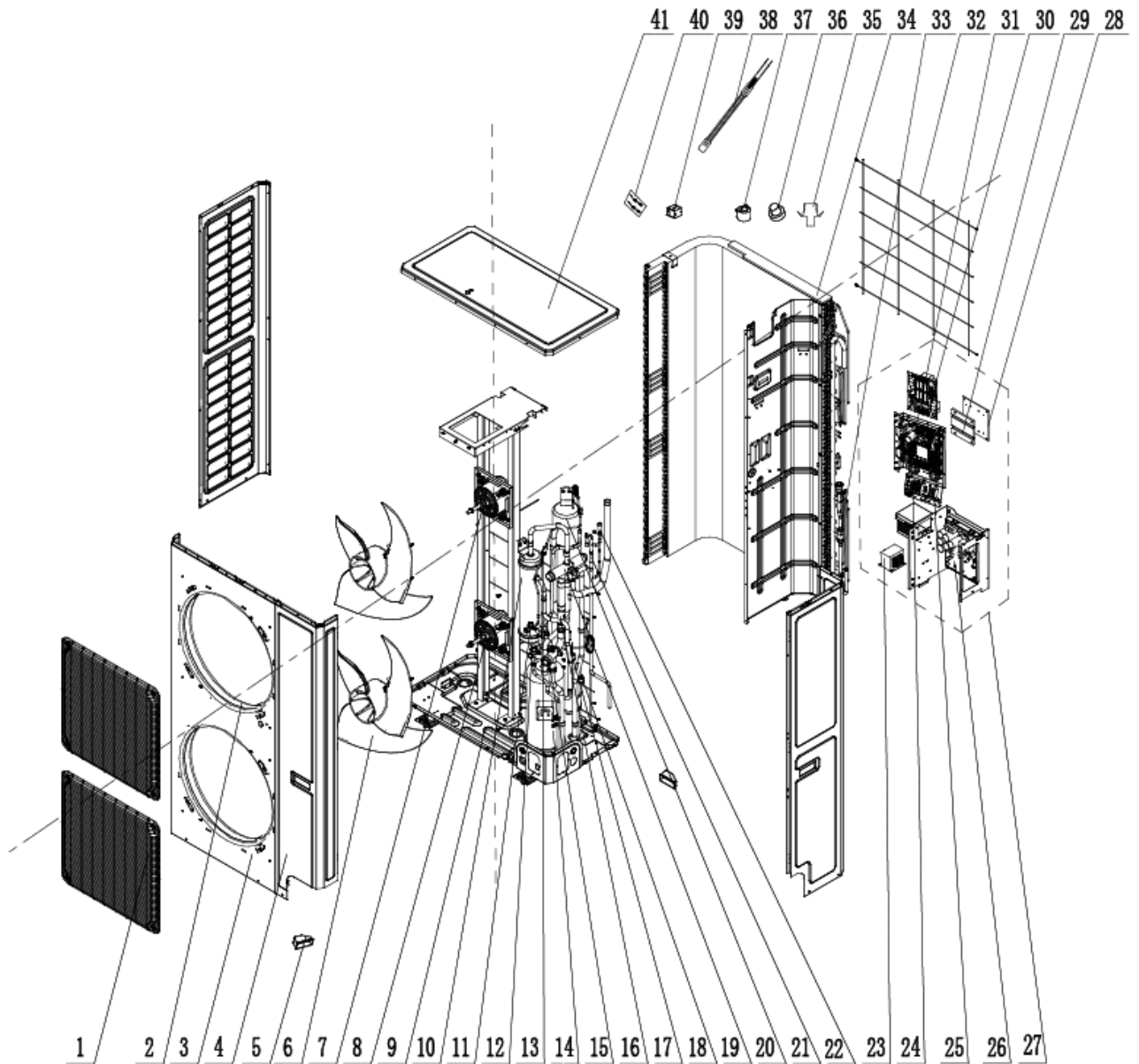

| NO | Model | FGR30Pd/DNa-X(O) | Qty |
|----|--------------------|------------------|-----|
| | Product Code | CF010W0750 | |
| | Part Name | Part Code | |
| 1 | Front Grill | 01572800003 | 2 |
| 2 | Diversion Circle | 10474100003 | 2 |
| 3 | Cabinet | 01514100016P | 1 |
| 4 | Front Side Plate | 01314100091P | 1 |
| 5 | Handle | 26235253 | 2 |
| 6 | Axial Flow Fan | 10434100008 | 2 |
| 7 | Brushless DC Motor | 15704100010 | 1 |
| 8 | Brushless DC Motor | 1570410001001 | 1 |
| 9 | Chassis Assy | 209058000011 | 1 |
| 10 | Oil Separator | 07424100050 | 1 |
| 11 | Cut off Valve | 07130208 | 1 |
| 12 | Cut off Valve | 07334100013 | 1 |

| NO | Model | FGR30Pd/DNa-X(O) | Qty |
|----|-------------------------------|------------------|-----|
| | Product Code | CF010W0750 | |
| | Part Name | Part Code | |
| 13 | Strainer | 07415200002 | 1 |
| 14 | Compressor and Fitting | 00204100015 | 1 |
| 15 | Cut off Valve | 07334100014 | 1 |
| 16 | Strainer | 07414100024 | 1 |
| 17 | Pressure Protect Switch | 4602000902 | 1 |
| 18 | Pressure Protect Switch | 46020007 | 1 |
| 19 | 4-way Valve | 43000339 | 1 |
| 20 | Gas-liquid Separator | 07424100048 | 1 |
| 21 | One way Valve | 04324001 | 1 |
| 22 | Electronic Expansion Valve | 43044100190 | 1 |
| 23 | Reactor | 4313017401 | 1 |
| 24 | Terminal board | 42011221 | 1 |
| 25 | Terminal board | 420001000019 | 1 |
| 26 | Main Board | 30223000039 | 1 |
| 27 | Electric Box Assy | 100002001274 | 1 |
| 28 | Radiator | 49018000080 | 1 |
| 29 | Radiator | 49018000088 | 1 |
| 30 | Filter Board | 30228000015 | 1 |
| 31 | Main Board | 300027000244 | 1 |
| 32 | Rear Grill | 01574100014 | 2 |
| 33 | Filter | 0341010701 | 1 |
| 34 | Condenser Assy | 000100000050 | 1 |
| 35 | Drainage Joint | 26113009 | 1 |
| 36 | Drainage hole Cap | 76715005 | 3 |
| 37 | Electric Expand Valve Fitting | 4304413205 | 1 |
| 38 | Electric Heater(Compressor) | 7651540714 | 1 |
| 39 | Magnet Coil | 4300040032 | 1 |
| 40 | Sensor Sub-assy | 390002000027 | 1 |
| 41 | Coping | 01264100052P | 1 |

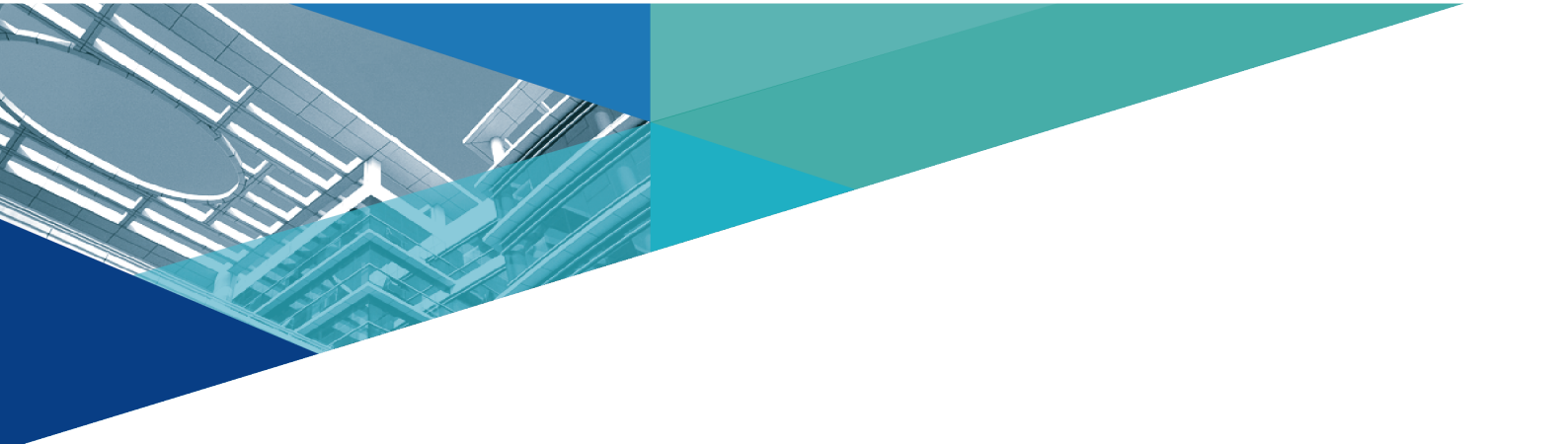

GREE ELECTRIC APPLIANCES, INC. OF ZHUHAI 519070

Add: West Jinji Rd, Qianshan Zhuhai, Guangdong, China

Tel: (+86-756)8522218

Fax: (+86-756)8669426

E-mail: gree@gree.com.cn www.gree.com

JF00303352