



中央空调 BACnet 网关套件 MG30-24/D2 (B)

Gateway Kit MG30-24/D2(B)

说明书

Owner's Manual

商用空调

Commercial Air Conditioners



感谢您选购格力商用空调，使用本产品前，请仔细阅读此用户手册，并妥善保管以备日后参考。



Thank you for choosing Commercial Air Conditioners ,please read this owner's manual carefully before operation and retain it for future reference.

User Notice

Thanks for purchasing GREE MG30-24/D2(B) gateway kits. Please read this manual carefully prior to installation and operation and strictly observe all installation and operation instructions covered in the manual.

Special attentions shall be paid to the following two marks **WARNING** and **CAUTION**.

 WARNING!	This mark indicates procedures, which if improperly performed, might lead to the death or serious injury of the users.
 CAUTION!	This mark indicates procedures, which if improperly performed, might possibly result in damage to the device.

 WARNING!	
❶	Installation shall be performed by the qualified personnel, otherwise it would result in a fire hazard or electric shock.
❷	Do not place the plug of the power supply into the socket before it is dried and cleaned.
❸	Cut off the power supply before touching the electric element.
❹	Do not touch this device with wet hands, otherwise it would result in electric shock.
❺	Do use the power cable specified in this manual, otherwise it would result in a fire hazard.
❻	When the power cable is reversely connected or the power supply is beyond the rated range, it would result in a fire hazard or even damages to this device.
❼	Do install this device inside the electric control cabinet which is located indoor and then is locked.
❽	Do install this device where it will not be subject to the electromagnetic interference or heavy dust.
 CAUTION!	
❶	Be sure the specified adaptor is used, otherwise this device would work improperly or even be damaged.
❷	Be sure this device is setup in place, otherwise it would result in communication fault.
❸	Be sure the communication line is connected to the correct interface, otherwise it would result in communication fault.
❹	After connection, lines should be protected with insulating tape to avoid oxidation and short circuits.
❺	Normal working conditions: Temperature: 0~55 °C; Humidity: less than 90%; Location: indoor (it is highly recommended to install this product in the electric control cabinet), not subject to direct sunlight, rain and snow etc.

Contents

1 Product Overview	1
1.1 Functional Overview	1
1.2 Parameter Specifications	1
1.3 Parts and Assembly.....	2
2 Interfaces and Indicating LEDs.....	4
2.1 Interfaces.....	4
2.2 Indicating LEDs	6
3 Field Installation.....	8
3.1 Outline Dimensions	8
3.2 Installation in the Electric Control Cabinet.....	9
3.3 Required Installation Space in the Electric Control Cabinet.....	10
3.4 BACnet Gateway Topology.....	11
3.5 Connection between the BACnet Gateway and the PC	13
3.6 Connection between the BACnet Gateway and Air Conditioners.....	14
Appendix A TCP/IP Setting.....	15
Appendix B BACnet Protocol.....	17
Appendix C Error List of the Indoor Unit.....	30
Appendix D Error List of the Outdoor Unit.....	31

1 Product Overview

1.1 Functional Overview

BACnet gateway kits MG30-24/D2(B) are intended to realize the data exchange between the air conditioning unit and BAS, and providing 8 I/Os (four inputs are E0, E1, E/A2, E/A3 and four outputs are E/A4, E/A5, A6, A7). E0 is the fire alarm interface. The status of other I/Os is mapped to the specific objects of the BACnet/IP bus and is defined by the user.

1.2 Parameter Specifications

2.2.1 BACnet Gateway TCP/IP (Default)

IP Address: 192.168.1.150

Subnet Mask: 255.255.255.0

Default Router: 192.168.1.1



Please reenergize the gateway to make the modified TCP/IP data take effect.

2.2.2 BACnet Interface Parameters

AC Type	Parameters
Indoor Units	Indoor unit general error
	Indoor unit error code
	Measured room temperature
	Set room temperature
	Running mode (status)
	Running mode (setting)
	ON/OFF
	Indoor fan speed (setting)
	Energy saving (setting)
	Remote control enable/disable (set temperature)
	Remote control enable/disable (start/stop)
Remote control enable/disable (all)	
Outdoor Units	Outdoor ambient temperature
	Compressor
	Outdoor unit general error
	Remote shut unit
I/O Module	Fire alarm input
	Digital input 2
	Digital input 3
	Digital input 4
	Digital output 1
	Digital output 2
	Digital output 3
	Digital output 4
Other	First indoor unit number
	First outdoor unit number

1.3 Parts and Assembly

See figures below for the real parts and final assembly of the BACnet gateway kit MG30-24/D2(B).

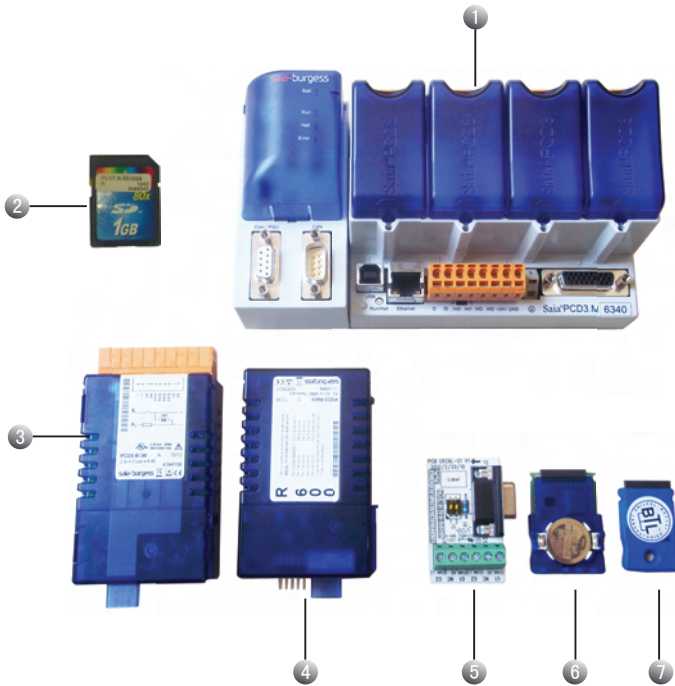

No.	Parts Name
1	PCD3.M6340
2	PCD7.R-SD1024
3	PCD3.B100
4	PCD3.R600
5	Communication interface board ZTS6LA
6	Battery module
7	PCD7.R560

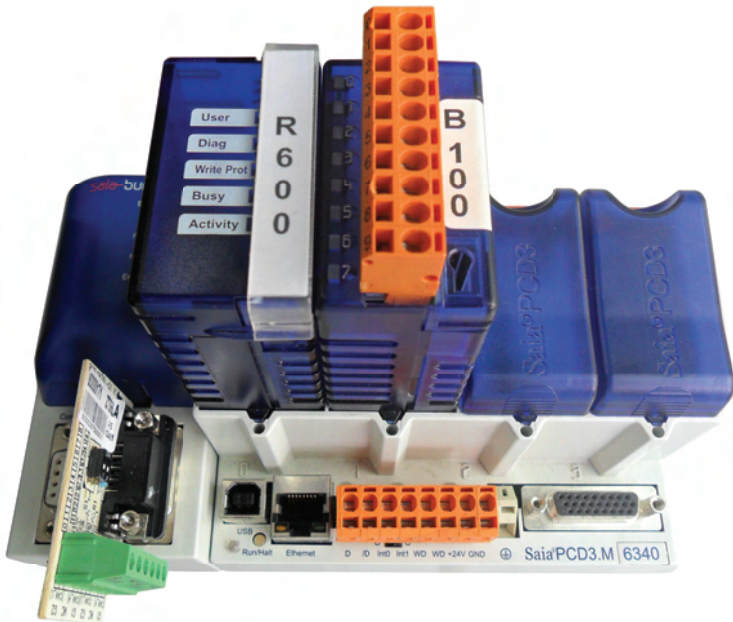
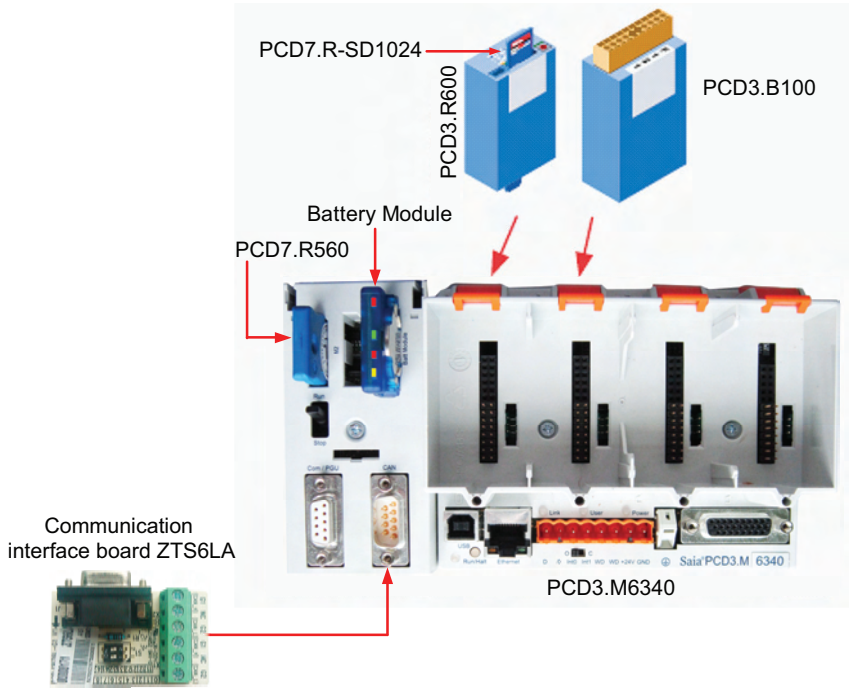

2 Interfaces and Indicating LEDs

2.1 Interfaces

Interfaces as shown in the figure below are available.

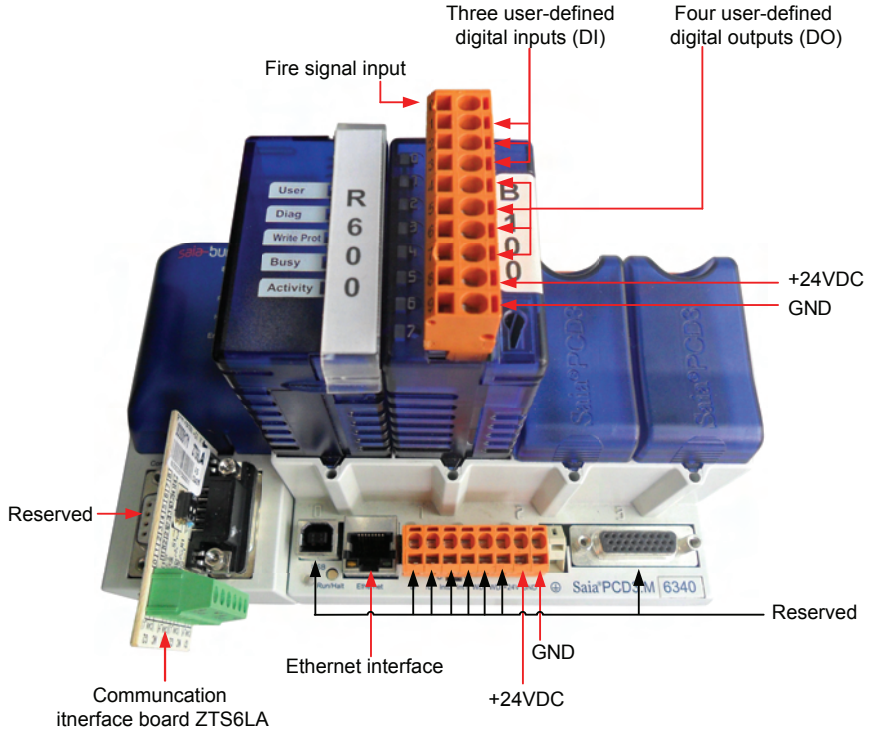

2.1.1 Power Interfaces

Power supply is input through the wiring terminals. Power Supply: 24VDC -20/+25% incl. 5% ripples as per EN/IEC 61131-2, 175mA/4.2W normal, 500mA/12W maximum.

2.1.2 Communication Interface Board

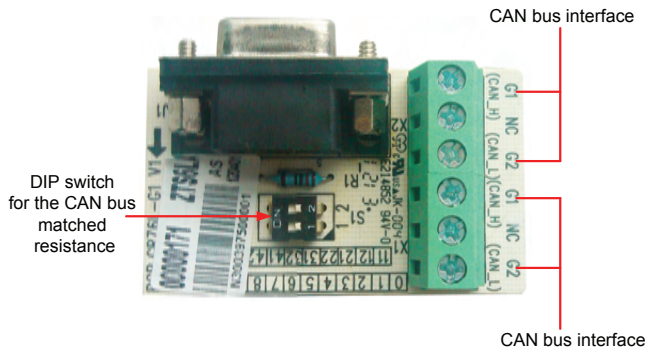
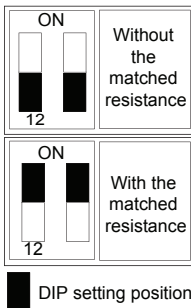

Printed Mark	Terminal	Pin	Description
S1(1)	DIP switch	1/2: without the matched resistance	As shown in the figure above, when the switch is set to the end "ON", it indicates the matched resistance is added; when the switch is set to the digital end "1/2", it indicates the matched resistance is not added. The later is the default.
S1(2)		ON: with the matched resistance	
G1	Wiring terminal	G1: CAN_H	Two-wire line, used to connect the CAN bus.
G2		G2: CAN_L	

2.1.3 I/O Module

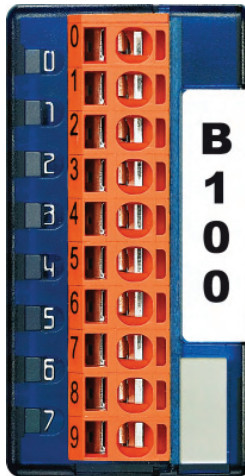

Printed Mark	Terminal	Pin	Description
E0(0)	Wiring terminal	0: fire alarm input	Two-wire signal line. 0 is the fire alarm input and other I/Os can be defined by the user.
E1(1)		1: undefined	
E/A2(2)		2: undefined	
E/A3(3)		3: undefined	
E/A4(4)	Wiring terminal	4: undefined	Two-wire signal line. I/Os can be defined by the user.
E/A5(5)		5: undefined	
A6(6)		6: undefined	
A7(7)		7: undefined	

Note: when the input voltage between DI and GND is 24V,the DI interface is enabled;when the output voltage between DO and GND is 24V,the DO interface is enabled.

2.2 Indicating LEDs

2.2.1 Power Indicating LED

As shown in the figure below, the printed mark “Power” represents the power indicating LED. When it turned to red, it indicates the BACnet gateway is powered on; when it turns off, it indicates the BACnet gateway is powered off.

2.2.2 PCD 3.M6340 Indicating LED

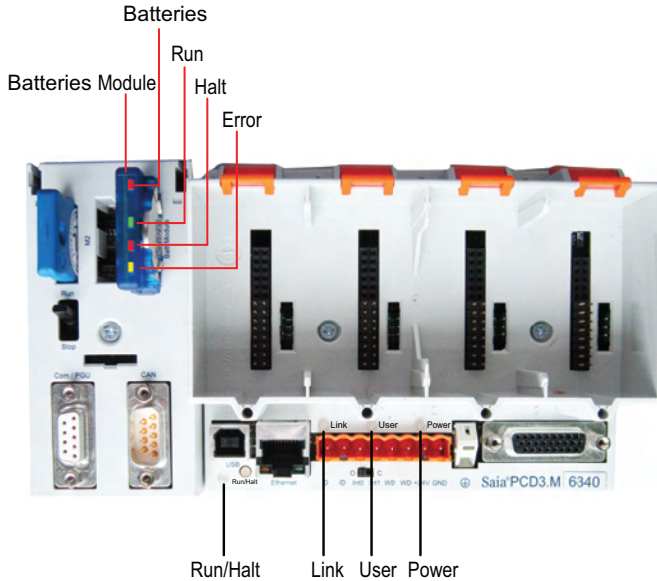

CPU type	PCD3.M6340 battery module			
LED	Batt	Run	Halt	Error
Colour	Red	Green	Red	Yellow
Run	○	●	○	○
Run cond.	○	●/○	○	○
Run with error	○	●	○	●
Run cond. with error	○	●/○	○	●
Stop	○	○	○	○
Stop with error	○	○	○	●
Halt	○	○	●	○
System diagnostics	○	●/○	●/○	●/○
Batt./Super Cap voltage absent	●	○	○	○

○LED off ●LED on ●/○LED flashing

Start	Self-diagnosis for approx. 1 sec. after switching on or after a Restart
Run	Normal processing of the user program after Start. Where a programming unit is connected via a PCD8.K11x in PGU mode (e.g. PG5 in PGU mode), the CPU automatically goes into the Stop state and not the Run state; this is for safety reasons
Run conditional	Conditional Run state. A condition has been set in the debugger (Run until...), which has not yet been met
Run with error	Same as Run, but with an error message
Run cond. with error	Same as conditional Run, but with an error message
Stop	The Stop state occurs in the following cases: <ul style="list-style-type: none"> • Programming unit in PGU mode connected when the CPU was switched on • PGU stopped by programming unit • Condition for a COND.RUN has been met
Stop with error	Same as Stop, but with an error message
Halt	The Halt state occurs in the following cases: <ul style="list-style-type: none"> • Halt instruction processed • Serious error in user program • Hardware fault • No program loaded • no communication module on an S-Bus PGU or Gateway Master port
System diagnostics	If the PLC doesn't go to RUN after 2 minutes, you have to send it for repair
Reset	The RESET state has the following causes: <ul style="list-style-type: none"> • Supply voltage too low • Firmware not starting up

2.2.3 PCD3.R600 Indicating LED



The memory module has 5 indicating LEDs:

LED	Meaning
User	User LED, set by the user program with the base address of the module (SET = off; RES = on)
Diag	Flashes when there is an error message

Write Prot	Active when a "write-protected" condition is detected (read-only SD switch, BCD switch or software)
Busy	Do not remove the module when this LED is on.
Activity	Works as with a hard disk drive; flashes when data being processed

Note: Do not remove the card when the "Busy" LED is on.

2.2.4 I/O Module Indicating LED

LED 0...7 Terminal 0

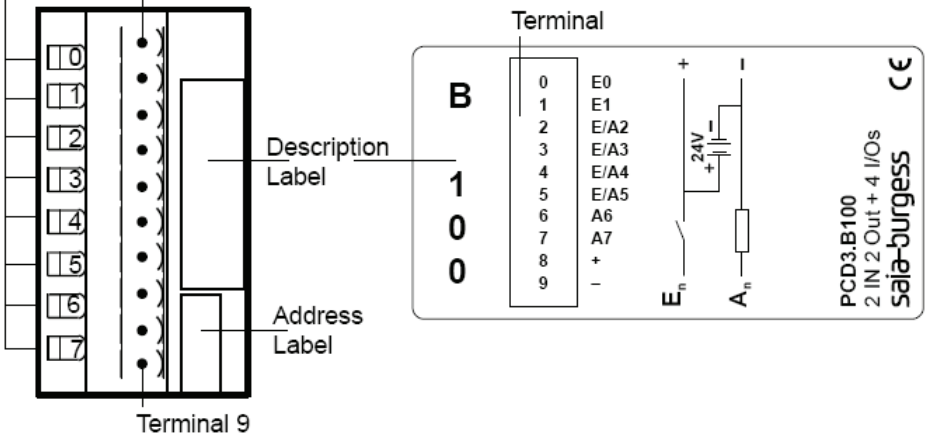

As shown in the figure above, E0, E1, E/A2, E/A3 indicating LEDs are marks for four inputs and E/A4, E/A5, A6, A7 indicating LEDs are marks for four outputs. Among them, when any one is the high-level input/output, the corresponding LED will light on. (Voltage between each I/O and GND is 24V. I/O is at the high level.)

3 Field Installation

3.1 Outline Dimensions

Unit:mm

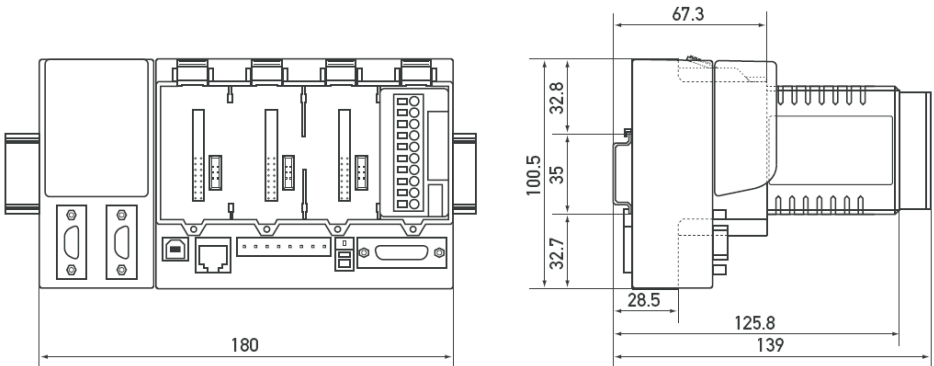

3.2 Installation in the Electric Control Cabinet

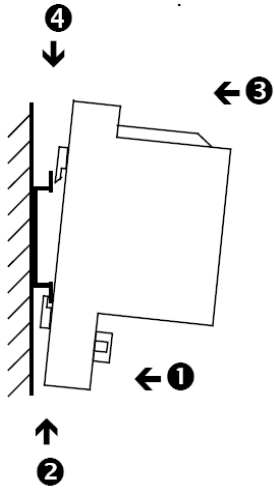

The PCD3 CPUs and the module holders can be snapped onto the 35mm top-hat rail according to DIN EN60715 TH35 (formerly DIN EN50022). (Remember: the PCD2 needs two top-hat rails).

Mounting the PCD3 on the top-hat rail:

- (1) Press the bottom of the housing onto the mounting surface.
- (2) Press upwards against the top-hat rail
- (3) Press the top of the housing against the mounting surface and snap into place.
- (4) Push the housing down onto the top-hat rail to ensure that it is secure.

◆ Removal

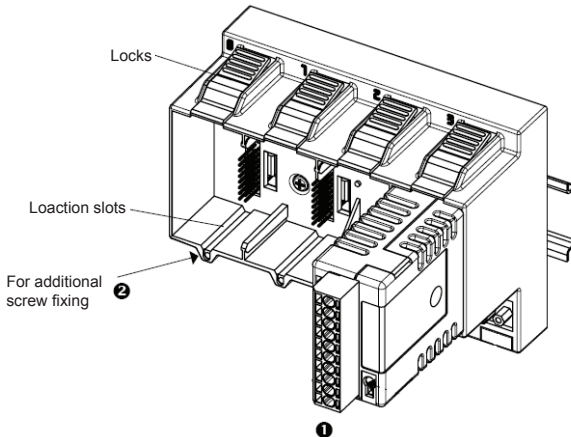

To removal the housing, push upwards and pull out.

- (1) Insert the module into the appropriate module location and press down to the bottom of the CPU or module holder housing.

- (2) For security, a guide rail is provided to prevent the module being inserted the wrong way round. In awkward positions, the modules can also be secured with a screw 3X8mm which is commercial available from the hardware store.

3.3 Required Installation Space in the Electric Control Cabinet

The minimal required installation space is as shown in the figure below.

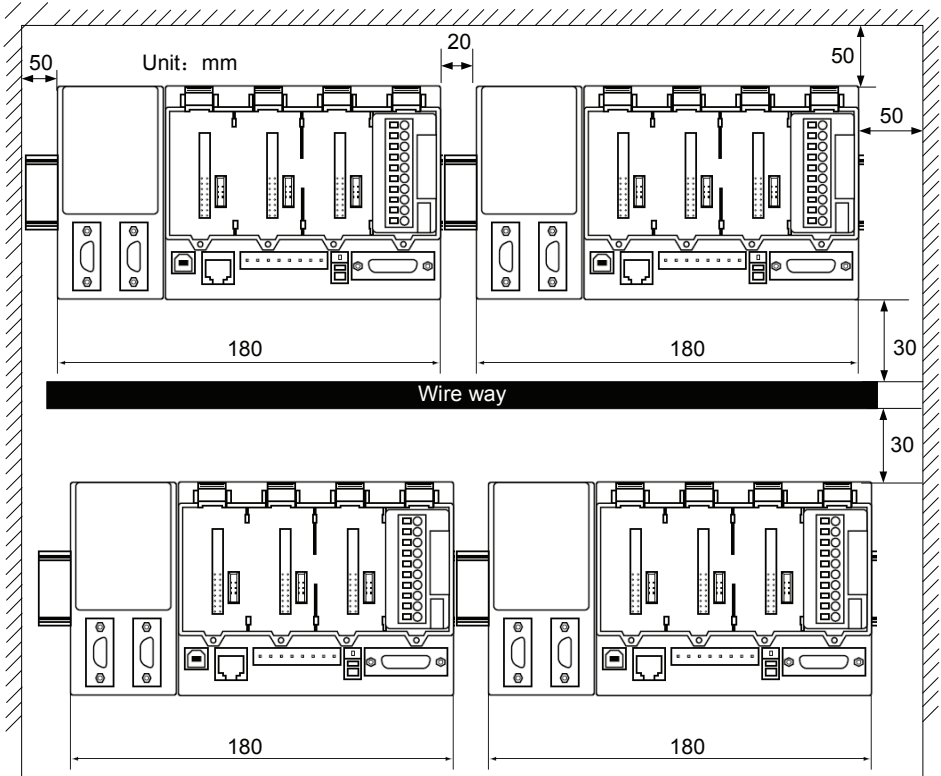

3.4 BACnet Gateway Topology

3.4.1 How to Connect the Gateway

As shown in the topological diagram below, the whole system consists of the internal network of the air conditioning unit and BACnet/IP network through which the communication data can be exchanged.

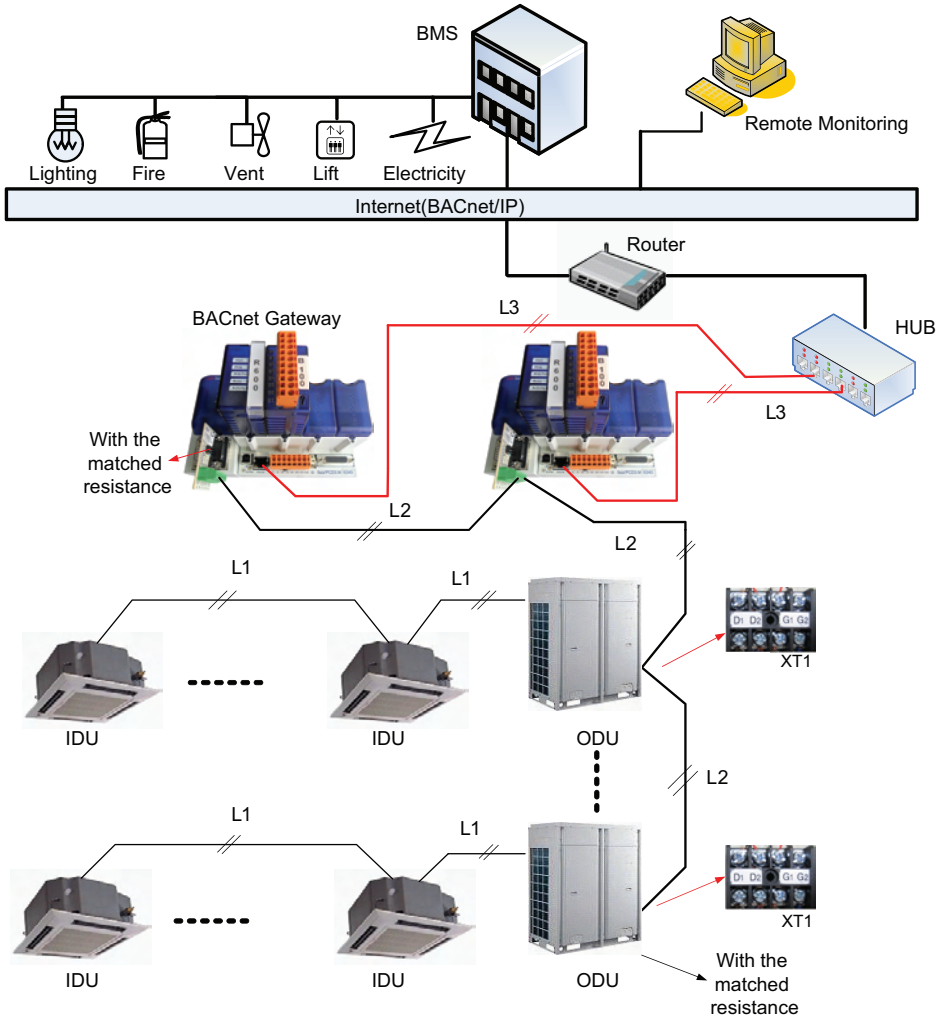

In the network above, L3 is the line for RJ45 and L2 is the twisted pair line.

Note: the total length of L2 can not exceed 500m and a matched resistance shall be added at both ends.

3.4.2 How to Configure the Gateway

One BACnet gateway can connect up to 8 outdoor units and 48 indoor units (that is, when the indoor units are more than 48 or the outdoor units are more than 8, another gateway will be required). Specific relation exists between the air conditioning units and the gateway and there is always a minimal indoor unit number and a minimal outdoor unit number for a gateway. Suppose the minimal indoor unit number is M, then all indoor units will be numbered among M to M+47. Suppose the minimal indoor unit number is N, then all indoor units will be numbered among N to N+7. During field installation, when only indoor units or outdoor units are present for a gateway, then it will fail to process the data from them.

The gateway shall be configured after its installation, however, before this please set the IP address of the PC the same with that of the BACnet gateway. See Appendix A for more details.

- (1) Open the IE browser and input the default IP address <http://192.168.1.150> into the address field.
- (2) The default username and password are both "Config".

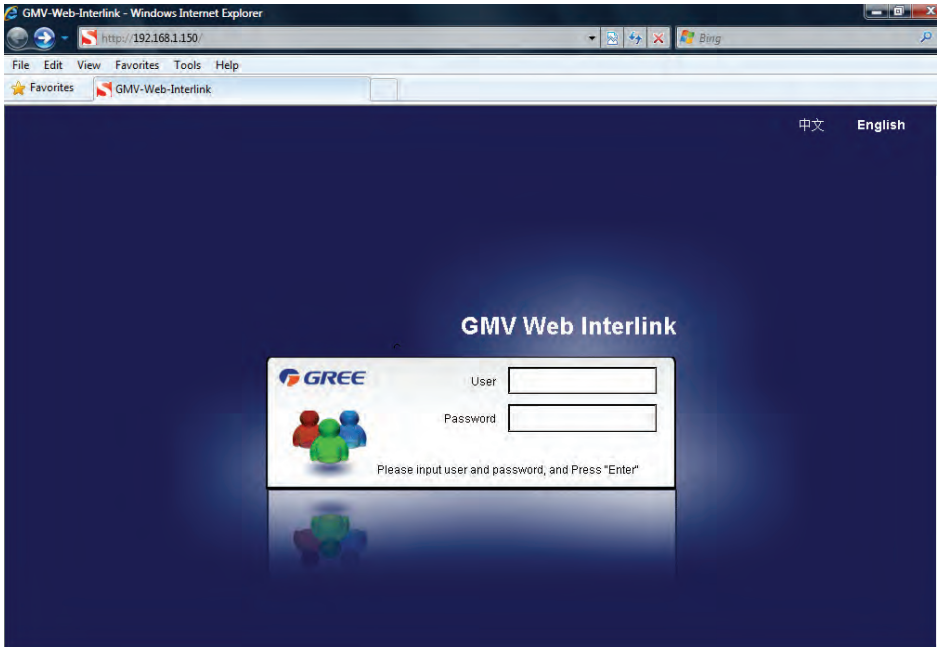

After input, press the "Enter" button to go to the setting page as shown below. The configurable objects include the minimum indoor unit number, the minimum outdoor unit number, CAN IP, BACnet IP address, subnet mask, and gateway address. Then, click the "Conform" button.



Gateway management default

MinIndoorNum	<input type="text" value="1"/>	(1-2001)
MinOutdoorNum	<input type="text" value="1"/>	(1-25)
CAN IP	<input type="text" value="80"/>	(64-126, best:80-87)

IP Address	172.16.52.200	
	<input type="text" value="172"/> <input type="text" value="16"/> <input type="text" value="52"/> <input type="text" value="200"/>	
Subnetmask	255.255.240.0	
	<input type="text" value="255"/> <input type="text" value="255"/> <input type="text" value="240"/> <input type="text" value="0"/>	
Gateway Address	172.16.1.1	
	<input type="text" value="172"/> <input type="text" value="16"/> <input type="text" value="1"/> <input type="text" value="1"/>	Confirm

3.5 Connection between the BACnet Gateway and the PC

(1) Cross Connection

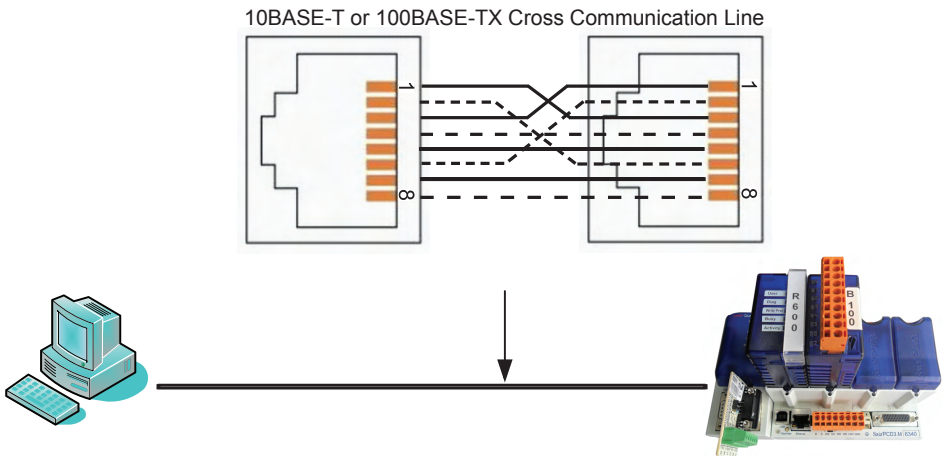

(2) Parallel Connection

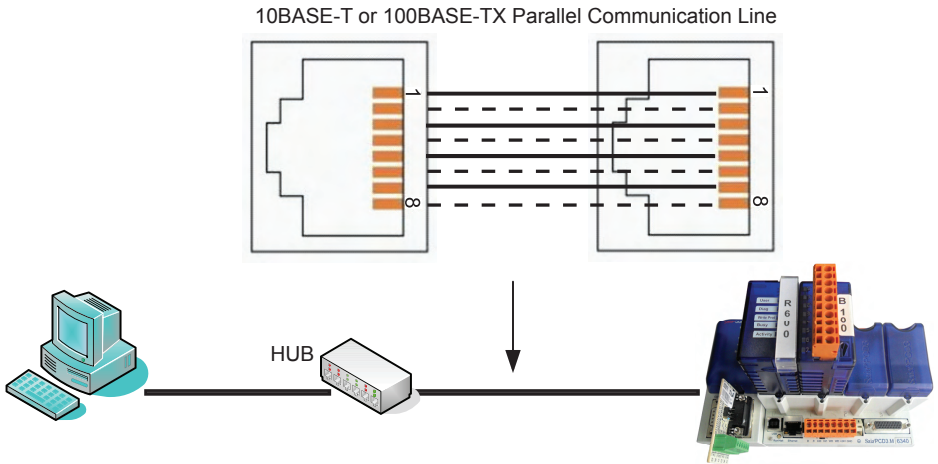

3.6 Connection between the BACnet Gateway and Air Conditioners

Twist pair, with the polarity the same as that of the master outdoor unit (address DIP setting is 0).

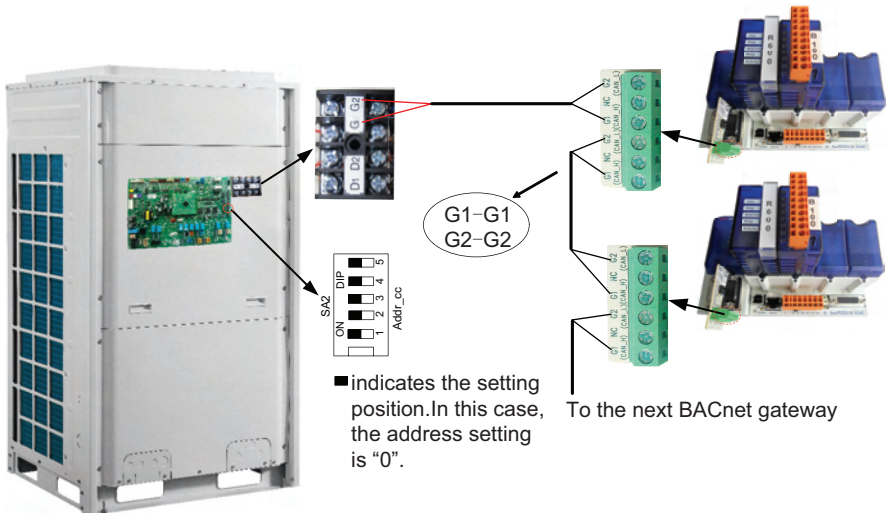

Appendix A TCP/IP Setting

- (1) Choose "Local Area Connection" on the PC.
- (2) Click "Properties".
- (3) Choose the option "Internet Protocol Version 4(TCP/IPv4)".
- (4) Choose "Use the following IP address" and set the TCP/IP properties.
- (5) DNS server addresses is not required to be set but keeps the default setting.
- (6) Click "OK" and this setting is finished.

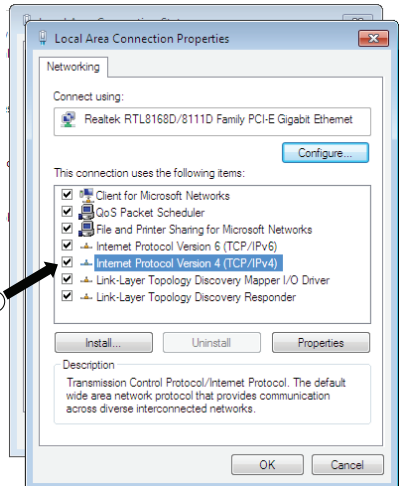
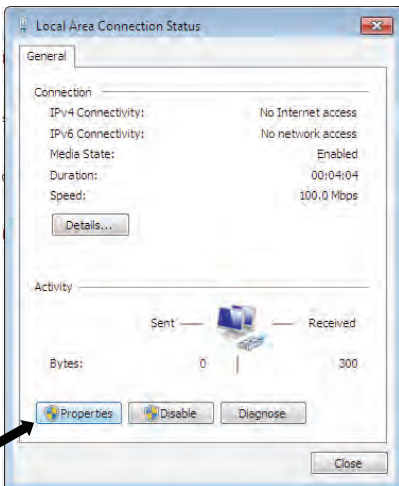
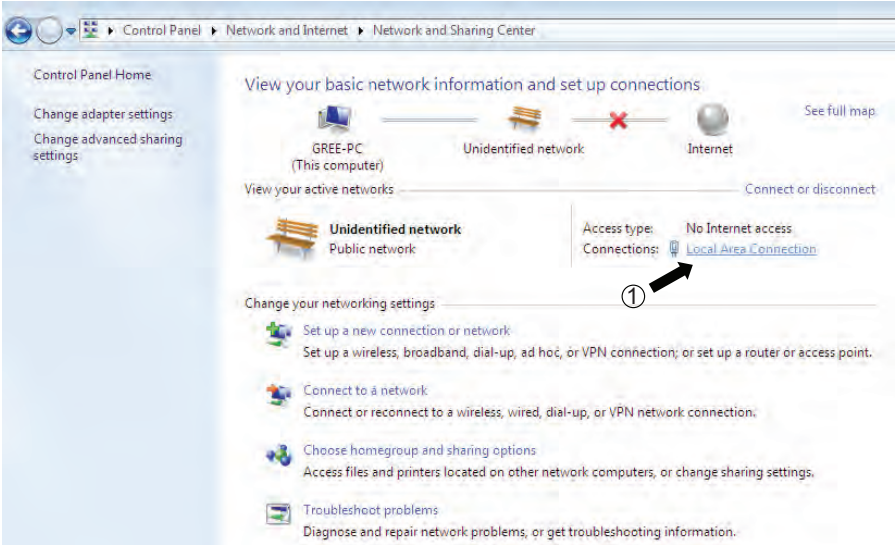

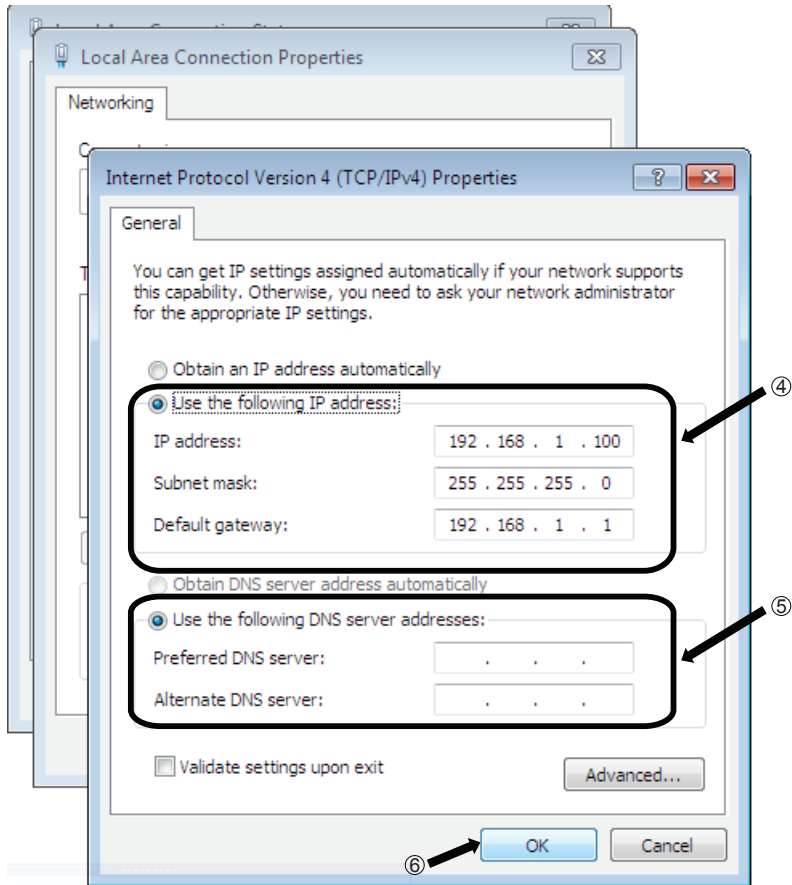

Appendix B BACnet Protocol

1. BACnet Protocol Instructions

1.1 What is BACnet

BACnet - A Data Communication Protocol for Building Automation and Control Networks - see bacnet.org. BACnet is a standard data communication protocol for Building Automation and Control Networks. BACnet is an open protocol, which means anyone can contribute to the standard, and anyone may use it. The only caveat is that the BACnet standard document itself is copyrighted by ASHRAE, and they sell the document to help defray costs of developing and maintaining the standard (just like IEEE or ANSI or ISO).

1.2 BACnet Collapsed Architecture

BACnet is based on a four-layer collapsed architecture that corresponds to the physical, data link, network, and application layers of the OSI model.

BACnet Layers					Equivalent OSI Layers	
BACnet Application Layer					Application	
BACnet Network Layer					Network	
ISO 8802-2(IEEE 802.2)Type 1		MS/TP	PTP	LonTalk	BVLL	Data Link
ISO 8802-3(IEEE 802.3)	ARCNET	EIA-485	EIA-232		UDP/IP	Physical

BACnet is defined for several physical layers.

BACnet/IP has only later been added to the original group.

1.3 BACnet device profiles

Today 6 device profiles are defined with BACnet:

- BACnet Operator Workstation (B-OWS)
- BACnet Building Controller (B-BC)
- BACnet Advanced Application Controller (B-AAC)
- BACnet Application Specific Controller (B-ASC)
- BACnet Smart Actuator (B-SA)
- BACnet Smart Sensor (B-SS)

Any device that implements all the required BACnet capabilities for a particular device type and interoperability area may claim to be a device of that particular type.Devices may also provide additional capabilities and shall indicate these capabilities in their PICS.

1.4 BACnet standard objects

ANSI/ASHRAE 135-2008 defines 30 BACnet standard objects as shown in the standard document.

Clause	Description	Page	Clause	Description	Page
12.1	Accumulator Object Type	132	12.16	Life Safety Zone Object Type	203
12.2	Analog Input Object Type	140	12.17	Loop Object Type	209
12.3	Analog Output Object Type	145	12.18	Multi-state Input Object Type	216
12.4	Analog Value Object Type	150	12.19	Multi-state Output Object Type	220
12.5	Averaging Object Type	155	12.20	Multi-state Value Object Type	224
12.6	Binary Input Object Type	158	12.21	Notification Class Object Type	229
12.7	Binary Output Object Type	163	12.22	Program Object Type	232
12.8	Binary Value Object Type	169	12.23	Pulse Converter Object Type	237
12.9	Calendar Object Type	174	12.24	Schedule Object Type	244
12.10	Command Object Type	176	12.25	Trend Log Object Type	249
12.11	Device Object Type	180	12.26	Access Door Object Type	257
12.12	Event Enrollment Object Type	188	12.27	Event Log Object Type	264
12.13	File Object Type	193	12.28	Load Control Object Type	270
12.14	Group Object Type	195	12.29	Structured View Object Type	279
12.15	Life Safety Point Object Type	197	12.30	Trend Log Multiple Object Type	281

1.5 BACnet services

BACnet services are divided into five segments:

- 1) Alarm and event Services
- 2) File Access Services
- 3) Object access Services
- 4) Remote device management Services
- 5) Virtual terminal Services

For each device profile certain services are mandatory.

1.6 Description of a service: BIBB

BACnet Interoperability Building Blocks (BIBBs) are collections of one or more BACnet services. These are prescribed in terms of an "A" and a "B" device. Both of these devices are nodes on a BACnet internetwork. In most cases, the "A" device will act as the user of data (client), and the "B" device will be the provider of this data (server). In addition, certain BIBBs may also be predicated on the support of certain, otherwise optional, BACnet objects or properties and may place constraints on the allowable values of specific properties or service parameters.

1.7 Description of a device type: PICS

PICS protocol implementation conformance statement All devices conforming to the BACnet protocol shall have a Protocol Implementation Conformance Statement (PICS) that identifies all of the portions of BACnet that are implemented.

A PICS is a written document, created by the manufacturer of a device, that identifies the particular

options specified by BACnet that are implemented in the device. A BACnet PICS is considered a public document that is available for use by any interested party.

2.BACnet protocol implementation conformance statement (PICS)

Date: 19.12.2011

Vendor Name: Saia-Burgess Controls AG(Vendor ID = 89)

Product Names: BACnet for PCD3.M6340

Product Model Number: PCD7.R560

Applications Software Version: GREE GMV BACNET II V1.0

Firmware Revision: BACnet_PCD3.Mxxx0_PCD2.M5xx0_1.16.55.blk

BACnet Protocol Revision: 1.7(BACnet ANSI/ASHRAE 135-2008)

2.1 Product Description:

The BACnet gateway applied for GREE VRF units links the units' internal network with the BACnet/IP network, and also provides BACnet BAS interfaces which enable the unit to be seamlessly integrated into the third party's BAS.

2.2 BACnet Standardized Device Profile (Annex L):

- BACnet Operator Workstation (B-OWS)
- BACnet Building Controller (B-BC)
- BACnet Advanced Application Controller (B-AAC)
- BACnet Application Specific Controller (B-ASC)
- BACnet Smart Sensor (B-SS)
- BACnet Smart Actuator (B-SA)

2.3 List all BACnet Interoperability Building Blocks Supported (Annex K):

2.3.1 Data Sharing BIBBs

- Data Sharing Read-Property-B DS-RP-B
- Data Sharing Read-Property-Multiple-B DS-RPM-B
- Data Sharing Write-Property-B DS-WP-B
- Data Sharing Write-Property-Multiple-B DS-WPM-B
- Data Sharing COV-B DS-COV-B
- Data Sharing COV-Unsolicited-B DS-COVU-B
- Data Sharing COV-Property-B DS-COVP-B

2.3.2 Device Management BIBBs

- Device Management-Dynamic Device Binding-A DM-DDB-A
- Device Management-Dynamic Device Binding-B DM-DDB-B
- Device Management-Dynamic Object Binding-B DM-DOB-B
- Device Management-DeviceCommunicationControl-B DM-DCC-B
- Device Management-TimeSynchronization-B DM-TS-B
- Device Management-UTCTimeSynchronization-B DM-UTC-B
- Device Management-ReinitializeDevice-B DM-RD-B
- Device Management-Backup and Restore-B DM-BR-B
- Device Management-Restart-B DM-R-B

Device Management-List Manipulation-B DM-LM-B

Device Management-Object Creation and Deletion-B DM-OCD-B

2.3.3 Network Management BIBBs

Network Management-Connection Establishment-B NM-CE-B

Network Management-Router Configuration-B NM-RC-B

2.4 Segmentation Capability:

- Able to transmit segmented messages Window Size 16
- Able to receive segmented messages Window Size 16

2.5 Standard Object Types Supported:

2.5.1 Standard Object Types Supported: Analog-Input-Object

1) Standard Object Types Supported: Analog-Input-Object

Dynamically Creatable	Dynamically Deleteable	Optional Properties Supported	Writable Properties	Proprietary Properties
□	□	Description Device Type Reliability Update_Interval Min_Pres_Value Max_Pres_Value Resolution COV_Increment Time_Delay Notification_Class High_Limit Low_Limit Deadband Limit_Enable Event_Enable Acked_Transitions Notify_Type Event_Time_Stamp	Present_Value COV_Increment Time_Delay High_Limit Low_Limit Deadband Limit_Enable Event_Enable	

2) Standard Object Types Supported: Analog-Value-Object

Dynamically Creatable	Dynamically Deleteable	Optional Properties Supported	Writable Properties	Proprietary Properties
□	□	Description Reliability Priority_Array Relinquish_Default COV_Increment Time_Delay Notification_Class High_Limit Low_Limit Deadband Limit_Enable Event_Enable Acked_Transitions Notify_Type Event_Time_Stamp	Present_Value COV_Increment Time_Delay High_Limit Low_Limit Deadband Limit_Enable Event_Enable	

3) Standard Object Types Supported: Binary-Input-Object

Dynamically Creatable	Dynamically Deleteable	Optional Properties Supported	Writable Properties	Proprietary Properties
□	□	Description Device_Type Reliability Inactive_Text Active_Text Change_Of_State_Time Change_Of_State_Count Time_Of_State_Count_Reset Elapsed_Active_Time Time_Of_Active_Time_Reset Time_Delay Notification_Class Alarm_Value Event_Enable Acked_Transitions Notify_Type Event_Time_Stamps	Present_Value Time_Delay Event_Enable	

4) Standard Object Types Supported: Binary-Output-Object

Dynamically Creatable	Dynamically Deleteable	Optional Properties Supported	Writable Properties	Proprietary Properties
□	□	Description Device_Type Reliability Inactive_Text Active_Text Change_Of_State_Time Change_Of_State_Count Time_Of_State_Count_Reset Elapsed_Active_Time Time_Of_Active_Time_Reset Minimum_Off_Time Minimum_On_Time Time_Delay Notification_Class Feedback_Value Event_Enable Acked_Transitions Notify_Type Event_Time_Stamps	Present_Value Time_Delay Event_Enable	

5) Standard Object Types Supported: Binary-Value-Object

Dynamically Creatable	Dynamically Deleteable	Optional Properties Supported	Writable Properties	Proprietary Properties
□	□	Description Reliability Inactive_Text Active_Text Change_Of_State_Time Change_Of_State_Count Time_Of_State_Count_Reset Elapsed_Active_Time Time_Of_Active_Time_Reset Minimum_Off_Time Minimum_On_Time Priority_Array Relinquish_Default Time_Delay Notification_Class Alarm_Value Event_Enable Acked_Transitions Notify_Type Event_Time_Stamps	Present_Value Time_Delay Event_Enable	

6) Standard Object Types Supported: Multistate-Input-Object

Dynamically Creatable	Dynamically Deleteable	Optional Properties Supported	Writable Properties	Proprietary Properties
<input type="checkbox"/>	<input type="checkbox"/>	Description Device_Type Reliability State_Text Time_Delay Notification_Class Alarm_Values Fault_Values Event_Enable Acked_Transitions Notify_Type Event_Time_Stamps	Present_Value Time_Delay Alarm_Values Fault_Values Event_Enable	

7) Standard Object Types Supported: Multistate-Value-Object

Dynamically Creatable	Dynamically Deleteable	Optional Properties Supported	Writable Properties	Proprietary Properties
<input type="checkbox"/>	<input type="checkbox"/>	Description Reliability State_Text Priority_Array Relinquish_Default Time_Delay Notification_Class Alarm_Values Fault_Values Event_Enable Acked_Transitions Notify_Type Event_Time_Stamps	Present_Value Time_Delay Alarm_Values Fault_Values Event_Enable	

2.6 Data Link Layer Options

- BACnet IP, (Annex J)
 - BACnet IP, (Annex J), Foreign Device
 - ISO 8802-3, Ethernet (Clause 7)
 - ATA 878.1, 2.5 Mb. ARCNET (Clause 8)
 - ATA 878.1, EIA-485 ARCNET (Clause 8), baud rate(s) _____
 - MS/TP master (Clause 9), baud rate(s):
 - MS/TP slave (Clause 9), baud rate(s):
 - Point-To-Point, EIA 232 (Clause 10), baud rate(s):
 - Point-To-Point, modem, (Clause 10), baud rate(s):
 - LonTalk, (Clause 11), medium: _____
 - Other:

2.7 Device Address Binding

Is static device binding supported? (This is currently necessary for two-way communication with MS/TP slaves and certain other devices.) Yes No

2.8 Networking Options

- Router, Clause 6 - List all routing configurations, e.g., ARCNET-Ethernet, Ethernet-MS/TP, etc.
- Annex H, BACnet Tunneling Router over IP
- BACnet/IP Broadcast Management Device (BBMD)

Does the BBMD support registrations by Foreign Devices? Yes No

2.9 Character Sets Supported

Indicating support for multiple character sets does not imply that they can all be supported simultaneously.

- ANSI X3.4 IBM™/Microsoft™ DBCS ISO 8859-1
- ISO 10646 (UCS-2) ISO 10646 (UCS-4) JIS C 6226

3. BACnet Object List

3.1 Supported BACnet Object Type

Based on the object type specified in the BACnet standard document, the object type and name of the supported the air conditioner parameters are listed as follows:

Object number	BACnet object type	Hexadecimal format	Decimal format	Air conditioner parameter name
0	Analog Input	X'0000 0000'	0	Analog Input (AI)
1	Analog Output	X'0040 0000'	4194304	Analog Output (AO)
2	Analog Value	X'0080 0000'	8388608	Analog Value (AV)
3	Binary Input	X'00C0 0000'	12582912	Binary Input (BI)
4	Binary Output	X'0100 0000'	16777216	Binary Output (BO)
5	Binary Value	X'0140 0000'	20971520	Binary Value (BV)
6	Calendar	X'0180 0000'	25165824	Calendar (CAL)
7	Command	X'01C0 0000'	29360128	Command (CMD))
8	Device	X'0200 0000'	96468992	Device (DEV)
9	Event-Enrollment	X'0240 0000'	37748736	Event-Enrollment (EE)
10	File	X'0280 0000'	41943040	File (FIL)
11	Group	X'02C0 0000'	46137344	Group (GRP)
12	Loop	X'0300 0000'	50331648	Loop (LP)
13	Multistate Input	X'0340 0000'	54525952	Multistate Input (MI)

14	Multistate Output	X'0380 0000'	58720256	Multistate Output (MO)
15	Notification Class	X'03C0 0000'	62914560	Notification Class (NC)
16	Program	X'0400 0000'	67108864	Program (PR)
17	Schedule	X'0440 0000'	71303168	Schedule (SCHED)
18	Averaging	X'0480 0000'	75497472	Averaging (AVG)
19	Multistate Value	X'04C0 0000'	79691776	Multistate Value (MV)
20	Trend Log	X'0500 0000'	83886080	Trend Log (TLOG)
21	Life Safety Point	X'0540 0000'	88080384	Life Safety Point (LSP)
22	Life Safety Zone	X'0580 0000'	92274688	Life Safety Zone (LSZ)
23	Accumulator	X'05C0 0000'	96468992	Accumulator (ACC)
24	Pulse Converter	X'0600 0000'	100663296	Pulse Converter (PC)
25	Event Log	X'0640 0000'	104857600	Event Log (ELOG)
26	Reserve	X'0680 0000'	109051904	Reserve
27	Trend Log Multiple	X'06C0 0000'	113246208	Trend Log Multiple (TLOGM)
28	load-control	X'0700 0000'	117440512	
29	structured-view	X'0740 0000'	121634816	
30	access-door	X'0780 0000'	125829120	

3.2 BACnet Point List

A BACnet object identifier value shall consist of 5 components:

BACnet ID(32bits)				
10bits	3bits	2bits	11bits	6bits
Object type	Equipment series	Equipment type(00,01,02,03)	Equipment range XX	Number intended to distinguish difference objects of the same object type and the same equipment type.

Object type: it indicates the BACnet object type, like AI, BO etc.

Equipment type: it indicates the gateway itself (0), indoor unit (1), outdoor unit (2), I/O module (3).

Equipment range: for the indoor units, it ranges from 0 to 47. Objects of the indoor unit numbered XX are the objects of the indoor unit with the project number XX plus the first indoor unit project number. The first indoor unit project number is a BACnet object of the BACnet gateway and is unique for each gateway. For the outdoor units, it ranges from 0 to 7. Objects of the outdoor unit numbered XX are objects of the outdoor unit with the project number XX plus the first outdoor unit project number. The first outdoor unit

project number is a BACnet object of the BACnet gateway and is unique for each gateway..

For the object "IndoorUnitAmbientTemp_01_01_01", if ID is $AI(0)+2048*64+XX*64+1=0+01*2048*64+01*64+1=131137$, its meaning is as shown in the table below.

BACnet Object ID (32bits)				
10bits	3bits	2bits	11bits	6bits
Object Type	Equipment series (VRF:0)	Equipment type (00,01,02,03)	Equipment range XX	Number intended to distinguish difference objects of the same object type and the same equipment type.
0: AI	0: VRF	1: Indoor unit	1	1

If the first indoor unit number of this BACnet gateway (FirstIndoorUnitNum_01_00_00, Object ID:1) is M, then "IndoorUnitAmbientTemp_01_01_01"(131137) means a parameter of the indoor unit numbered M+1.

No matter how many indoor and outdoor units there are for a BACnet gateway, it will always provide all BACnet objects for 48 indoor units and 8 outdoor units. In this way, some equipments in fact do not exist. One type of objects "IndoorUnitOnLine_01_01_XX" (ID: $BI(3)+2048*64+XX*64+63$) is intended to tell if the indoor unit really exists: if it is 0, it means the indoor unit does not exist, and the equipment range of this indoor unit has no meaning. It is the same case for the outdoor unit.

Detailed object points are listed in Table 3.2.

Table 3.2 BACnet Point List

No.	Parameter name	Object name	Object ID	Object Type	Instance Number	Present_Value	Units	Min_preset_value	Max_preset_value	Resolution	COV Enable	COV Increment
GMV indoor unit: "XX" in the object name indicates the result of subtracting the first indoor unit number by this indoor unit number, ranging from 0 to 47.												
1	Indoor Unit General Error	IndoorUnitGeneralError_01_01_XX	12713985+XX*64	BI	131073+XX*64	0:without; 1:with						
2	Indoor Unit Error Code	IndoorUnitErrorCode_01_01_XX	54657025+XX*64	MI	131073+XX*64	See Alarm codes						
3	Measured room temperature	IndoorUnitAmbientTemp_01_01_XX	131073+XX*64	AI	131073+XX*64	-20~100	°C	-20	100	1	TRUE	0.9
4	Set room temperature	IndoorUnitTempAdjust_01_01_XX	851968+XX*64	AV	131073+XX*64	16~30	°C				TRUE	0.9
5	Running mode(Status)	IndoorUnitModeStatus_01_01_XX	54657026+XX*64	MI	131074+XX*64	1: COOL; 2: DRY; 3: FAN; 4: HEAT; 5: AUTO; 6: Floor Heating; 7: 3D Heating; 8: Hydro Heating;					TRUE	
6	Running mode(setting)	IndoorUnitModeCommand_01_01_XX	79822849+XX*64	MV	131073+XX*64	1: COOL; 2: DRY; 3: FAN; 4: HEAT; 5: AUTO; 6: Floor heating; 7: 3D heating; 8: Hydro heating;						
7	On/Off(status)	OnOffStatus_01_01_XX	12713986+XX*64	BI	131074+XX*64	0:Off; 1:On					TRUE	
8	On/Off(setting)	OnOffCommand_01_01_XX	16908289+XX*64	BO	131073+XX*64	0:Off; 1:On						
9	Indoor fan speed (status)	FanSpeedStatus_01_01_XX	54657027+XX*64	MI	131075+XX*64	1: Off; 2: Ultra low; 3: Low; 4: Low-medium; 5: Medium; 6: Medium_high; 7: High; 8: Ultra high;					TRUE	

No.	Parameter name	Object name	Object ID	Object Type	Instance Number	Present_Value	Units	Min_present_value	Max_Present_Value	Resolution	COV Enable	COV Increment
10	Indoor fan speed(setting)	FanSpeedCommand_01_01_XX	79822850+XX*64	MV	131074+XX*64	1:AUTO; 2: LOW; 3: LOW-MEDIUM; 4: MEDIUM; 5: MEDIUM-HIGH; 6: HIGH						
11	Energy saving(setting)	EnergySavingCommand_01_01_XX	21102594+XX*64	BV	131074+XX*64	0: Off; 1: On						
12	Remote control enable/disable(set temperature)	RemoteTempShieldCommand_01_01_XX	21102595+XX*64	BV	131075+XX*64	0:Off; 1:On						
13	Remote control enable/disable(running mode)	RemoteModeShieldCommand_01_01_XX	21102596+XX*64	BV	131076+XX*64	0:Off; 1:On						
14	Remote control enable/disable(On/Off)	RemoteOnOffShieldCommand_01_01_XX	21102597+XX*64	BV	131077+XX*64	0: Off; 1: On						
15	Remote control disable(all)	RemoteLockCommand_01_01_XX	21102598+XX*64	BV	131078+XX*64	0: Off; 1: On						
GMV outdoor unit: "XX" in the object name indicates the result of subtracting the first outdoor unit number by this outdoor unit number, ranging from 0 to 7.												
16	Outdoor ambient temperature	OutdoorAmbientTemp 01_02_XX	262147+XX*64	AI	262147+XX*64	-30~155	°C	-30	155	1		
17	Compressor running status	Compressor 01_02_XX	12845061+XX*64	BI	262149+XX*64	0: Off; 1 :On						
18	Outdoor unit general error	OutdoorUnitErrorCode 01_02_XX	54788097+XX*64	MI	262145+XX*64	See Alarm codes						
19	Outdoor unit general error	OutdoorUnitGeneralError 01_02_XX	12845058+XX*64	BI	262146+XX*64	0: without; 1: with						
20	Remote shut unit	RemoteShutUnit 01_02_XX	21233668+XX*64	BV	262148+XX*64	0: Off; 1: On						

No.	Parameter name	Object name	Object ID	Object Type	Instance Number	Present_Value	Units	Min_present_value	Max_Present_Value	Resolution	COV Enable	COV Increment
Parameters of Device												
21	First indoor unit number	FirstIndoorUnitNum 01_00_00	3	AI	3	1~255		1	255	1	TRUE	0.9
22	First outdoor unit number	FirstOutdoorUnitNum 01_00_00	2	AI	2	1~16		1	16	1	TRUE	0.9
Parameters of Device												
23	Digit input 1	DigitInput1 01_03_00	12976129	BI	393217	0:Off,1:On						
24	Digit input 2	DigitInput2 01_03_00	12976130	BI	393218	0:Off,1:On						
25	Digit input 3	DigitInput3 01_03_00	12976131	BI	393219	0:Off,1:On						
26	Digit input 4	DigitInput4 01_03_00	12976132	BI	393220	0:Off,1:On						
27	Digit output 1	DigitOutput1 01_03_00	17170433	BO	393217	0:Off,1:On						
28	Digit output 2	DigitOutput2 01_03_00	17170434	BO	393218	0:Off,1:On						
29	Digit output 3	DigitOutput3 01_03_00	17170435	BO	393219	0:Off,1:On						
30	Digit output 4	DigitOutput4 01_03_00	17170436	BO	393220	0:Off,1:On						

Appendix C Error List of the Indoor Unit

Indoor Unit Error Codes		
Present_Value	Code	Error
0x00000001	00000000000000000000000000000001	Operation mode conflict
0x00000002	00000000000000000000000000000010	Full water protection
0x00000004	00000000000000000000000000000100	Quantity of controlled indoor unit uncomformable
0x00000008	000000000000000000000000000001000	Outlet tube temp sensor error
0x00000010	0000000000000000000000000000010000	Inlet tube temp sensor error
0x00000020	00000000000000000000000000000100000	Ambient temp sensor error
0x00000040	000000000000000000000000000001000000	Auxiliary electric heater protection
0x00000080	0000000000000000000000000000010000000	Freeze protection
0x00000100	00000000000000000000000000000100000000	Communication error
0x00000200	000000000000000000000000000001000000000	Supply over-current protection
0x00000400	0000000000000000000000000000010000000000	Indoor fan protection
0x00000800	00000000000000000000000000000100000000000	Indoor unit protection
0x00001000	000000000000000000000000000001000000000000	Indoor control element failure
0x00002000	0000000000000000000000000000010000000000000	Indoor main board failure
0x00004000	00000000000000000000000000000100000000000000	Indoor temp sensor error
0x00008000	000000000000000000000000000001000000000000000	Temp sensor error
0x00010000	0000000000000000000000000000010000000000000000	Water temp sensor error
0x00020000	00000000000000000000000000000100000000000000000	Indoor unit address conflict
0x00040000	000000000000000000000000000001000000000000000000	Indoor unit number conflict
0x00080000	0000000000000000000000000000010000000000000000000	Communication error between the gateway and the indoor unit
0x00100000	00000000000000000000000000000100000000000000000000	Other error
0x00200000	00000000000100000000000000000000000000000000	Without master indoor unit

Taking the error code 0x00000011 of the indoor unit for example, it indicates two errors are existing, operation mode conflict and inlet tube temperature sensor error. It is the same case for the outdoor unit.

Appendix D Error List of the Outdoor Unit

Outdoor Unit Error Codes		
Present_Value	Code	Error
0x00000001	0001	Outdoor ambient temp sensor error
0x00000002	0010	4-way valve blow-by protection
0x00000004	00100	Differential pressure protection
0x00000008	001000	Low pressure protection at the high side
0x00000010	0010000	Discharge temp sensor fall-off
0x00000020	00100000	Low discharge pressure protection
0x00000040	001000000	High pressure sensor error
0x00000080	0010000000	Discharge temp sensor error
0x00000100	00100000000	Low pressure sensor error
0x00000200	001000000000	High pressure protection
0x00000400	0010000000000	Low pressure protection
0x00000800	00100000000000	Discharge protection
0x00001000	001000000000000	Over-current protection
0x00002000	0010000000000000	Communication error
0x00004000	00100000000000000	Defrosting temp sensor error
0x00008000	001000000000000000	Sub-cooler temp sensor error
0x00010000	0010000000000000000	Suction temp sensor error
0x00020000	00100000000000000000	Compressor drive board failure
0x00040000	001000000000000000000	Compressor drive board malfunction
0x00080000	00100000000000000000000	Compressor drive board voltage protection
0x00100000	001000000000000000000000	Fan drive board failure
0x00200000	0010000000000000000000000	Fan drive board malfunction
0x00400000	00100000000000000000000000	Fan drive board voltage protection
0x00800000	001000000000000000000000000	Other error
0x01000000	0010000000000000000000000000	Communication error of module 1
0x02000000	00100000000000000000000000000	Communication error of module 2
0x04000000	001000000000000000000000000000	Communication error of module 3
0x08000000	0010000000000000000000000000000	Communication error of module 4
0x10000000	00100000000000000000000000000000	Communication error between the gateway and the outdoor unit
0x20000000	00100000000000000000000000000000	System capacity error
0x40000000	001000000000000000000000000000000	System pressure sensor error

珠海格力电器股份有限公司
GREE ELECTRIC APPLIANCES, INC. OF ZHUHAI

地址：珠海市前山金鸡西路 邮编：519070

电话：4008 365 315 (0756)8617555 (客户服务中心)

<http://www.gree.com>

Add: West Jinji Rd, Qianshan, Zhuhai, Guangdong, China, 519070

Tel: (+86-756) 8522218 Fax: (+86-756) 8669426

E-mail: gree@gree.com.cn www.gree.com



64134100013