

13	压缩机
20	风扇电机
22	电容
24	变压器
29	主板
31	显示板
32	传感器
33	遥控器
34	连接导线
35	显示屏

A

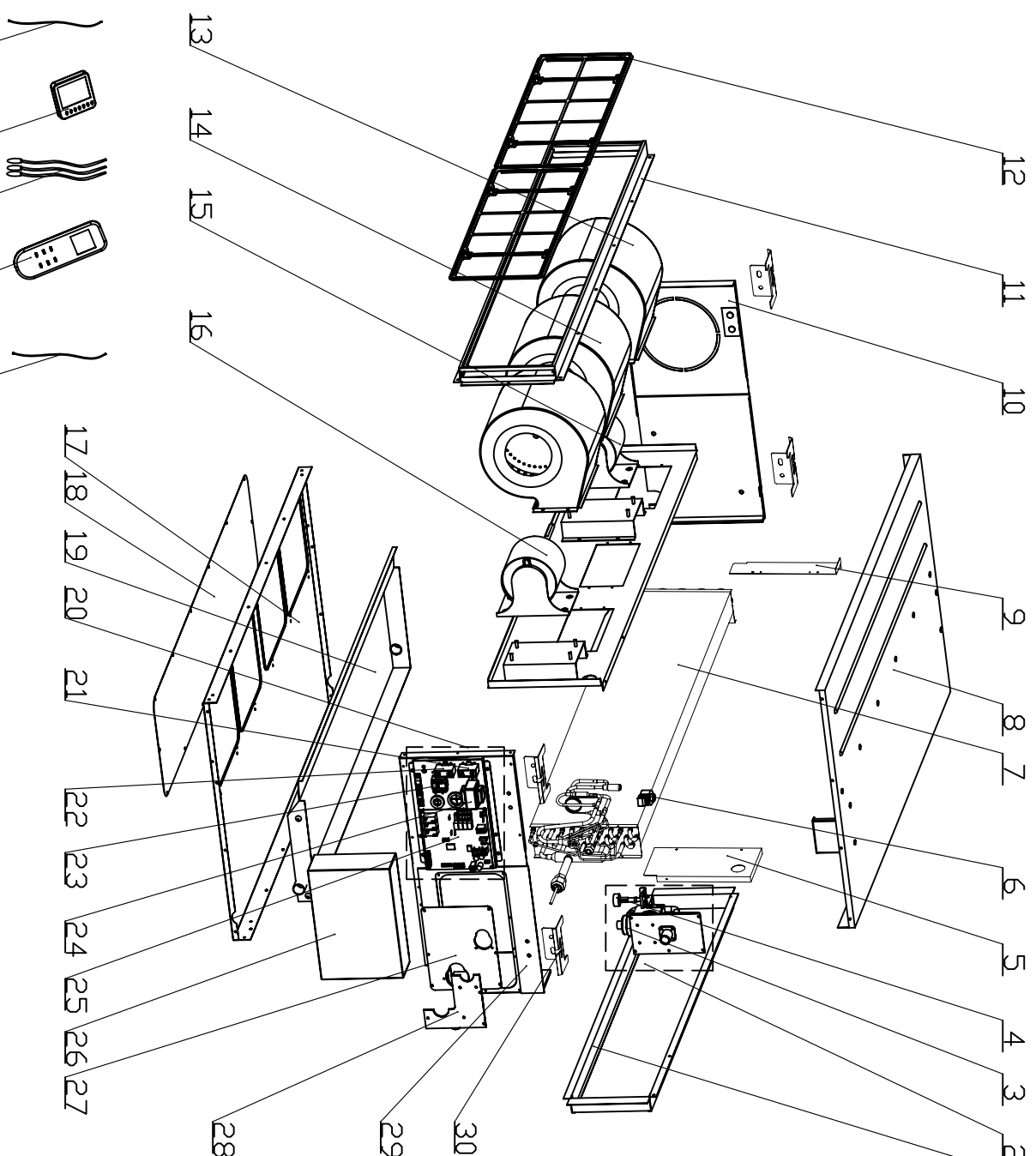

1 2 3

2

3

4

序号	代号	名称	数量	材料	材料规格	单位	总计	备注
35		连接导线(3芯)					*	
34		Remote Controller					*	
33		Sensor sub-assy					*	
32		Display Board					*	
31		Connecting Wire					*	
30		Hook					*	
29		Left Side Plate Assy					*	
28		Seal Of Connection Pipe					*	
27		Seal Of Left Side Rate Sub-assy					*	
26		Electric Box Cover					*	
25		Main Board					*	
24		Transformer					*	
23		Terminal Board					*	
22		Capacitor CBB61					*	
21		Capacitor CBB61					*	
20		Electric Box Assy					*	
19		Water Tray Assy					*	
18		Cover Of Air-In					*	
17		Bottom Cover Plate Assy					*	
16		Fan Motor					*	
15		Fan Motor					*	
14		Motor					*	
13		Motor					*	
12		Filter Sub-Assy					*	
11		Air intake side-board Sub-assy					*	
10		Right Side Plate Assy					*	
9		Right Support of Evaporator					*	
8		Top Cover Board Assy					*	
7		Evaporator Assy					*	
6		Electric expand valve fitting					*	
5		Left Support of Evaporator Sub-Assy					*	
4		Water Level Switch					*	
3		Water Pump					*	
2		Water Pump Assy					*	
1		Air-Outlet Side Board assy					*	

A

产品型号: GNV-R112P5VMB-K	零件图
设计: 刘廷廷	091225
审核: 魏建强	091225
工艺: 魏建强	091225
会签: 魏建强	091225
图样标记	重量
比例	1:8
材料编号	VR112P5VMB-K/BZ000000

B