



Service Manual

Multi Variable Air Conditioners Indoor Units

(GC202010-XII)

CONTENTS

PRODUCT	1
1 Product List	2
1.1 Floor Standing Type	2
1.2 High Static Pressure Duct Type	2
1.3 Low Static Pressure Duct Type	2
1.4 4-way Cassette	3
1.5 Compact 4-way Cassette	3
1.6 360°Air Discharge Compact Cassette	4
1.7 2-way Cassette	4
1.8 1-way Cassette	4
1.9 Floor Ceiling	4
1.10 Fresh Air Processing	5
1.11 Slim Duct Type	5
1.12 Air Handler Type Indoor Unit	6
1.13 Console Type Indoor Unit	6
1.14 Wall Mounted Type Indoor Unit	7
1.15 Super High Static Pressure Duct Type Indoor Unit	11
1.16 AHU-KIT Type	12
1.17 Concealed Floor Standing Type	13
1.18 360°Air Discharge Cassette	13
1.19 Heat Storage Module	13
2 Nomenclature	14
2.1 Nomenclature of Indoor Units	14
3 Specifications	15
3.1 Floor Standing Type	15
3.2 High Static Pressure Duct Type	16
3.3 Low Static Pressure Duct Type	17
3.4 4-way Cassette Type	20
3.5 Compact 4-way Cassette Type	21
3.6 360°Air Discharge Compact Cassette	22
3.7 2-way Cassette Type	23
3.8 1-way Cassette Type	24
3.9 Floor Ceiling Type	24
3.10 Fresh air Processing Unit	26
3.11 Slim Duct Type	28
3.12 Air Handler Type Indoor Unit	30
3.13 Console Type Indoor Unit	31
3.14 Wall Mounted Type Indoor Unit	32
3.15 Super High Static Pressure Duct Type Indoor Unit	52
3.16 AHU-KIT Type	55

3.17 Concealed Floor Standing Type.....	58
3.18 360°Air Discharge Cassette.....	59
CONTROL	63
1 Operation Flowchart.....	64
2 Wired Controller.....	65
2.1 Control Panel.....	65
2.2 Installation and Removal	68
3 Remote Controller.....	71
3.1 Remote Controller YAP1F.....	71
3.2 Remote Controller YV1L1	72
4 Panel Display	73
4.1 Control Panel.....	73
4.2 Operational Instruction.....	73
5 Introduction to Unit Functions	77
5.1 Engineering Application Functions Operated through the XK46 Wired Controller	78
5.2 Engineering Application Functions Operated through the XK49 Wired Controller	93
5.3 Engineering Application Functions Operated through the XK79 Wired Controller	95
5.4 Engineering Application Functions Operated through the YV1L1 Remote Controller	99
5.5 Engineering Application Functions Operated through the YAP1F Remote Controller	104
INSTALLATION	105
1 Engineering Installation Preparation and Notice	106
1.1 Installation Notice	106
1.2 Installation Key Points and Importance.....	106
2 Installation Materials Selection	107
2.1 Refrigerant Piping.....	107
2.2 Condensate Water Pipe.....	108
2.3 Insulation Material	108
2.4 Communication Cable and Control Cable.....	108
2.5 Power Cable.....	109
2.6 Hanger Rod and Support.....	109
3 Installation of Indoor Unit	109
3.1 Installation of Floor Standing Indoor Unit	109
3.2 Installation of High Static Pressure Duct Type Unit	111
3.3 Installation of Low Static Pressure Duct Type Unit.....	114
3.4 Installation of 4-way Cassette Type Unit	119
3.5 Installation of Compact 4-way Cassette Type Unit	121
3.6 Installation of 360°Air Discharge Compact Cassette Type Unit.....	123
3.7 Installation of Compact 2-way Cassette Type Unit	125
3.8 Installation of Compact 1-way Cassette Type Unit.....	127
3.9 Installation of Floor Ceiling Type Unit.....	128
3.10 Installation of Fresh air Processing Unit.....	130

3.11 Installation of Slim Duct Type Unit.....	134
3.12 Installation of Air Handler type Indoor Unit	135
3.13 Installation of Wall-Mounted Unit.....	137
3.14 Console Type Indoor Unit	142
3.15 Installation of Super High Static Pressure Duct Type Indoor Unit.....	143
3.16 Installation of AHU-KIT Type	148
3.17 Installation of Concealed Floor Standing Type	161
3.18 Installation of 360° Air Discharge Cassette Type Unit	163
3.19 Installation of Heat Storage Module	165
4 Installation of Drain Pipe.....	166
4.1 Precautions When Doing the Piping Work	166
4.2 Installing the Drain Pipes	167
4.3 Precautions When Doing Riser Piping Work	169
4.4 Testing of Drain Piping	169
5 Electrical Installation	169
MAINTENANCE	171
1 Troubleshooting.....	172
1.1 Malfunction List for the Wired Controller	172
1.2 Exception Analyzing and Troubleshooting.....	172
2 After-sales Emergency Measures.....	184
3 Wiring Diagram	184
3.1 Floor Standing Type.....	185
3.2 High Static Pressure Duct Type	185
3.3 Low Static Pressure Duct Type	187
3.4 4-way Cassette Type	189
3.5 Compact 4-way Cassette Type	191
3.6 360° Air Discharge Compact Cassette Type	192
3.7 2-way Cassette Type	192
3.8 1-way Cassette Type	193
3.9 Floor Ceiling Type.....	193
3.10 Fresh air Processing Unit.....	194
3.11 Slim Duct Type.....	196
3.12 Air Handler Type Indoor Unit.....	197
3.13 Console Type Indoor Unit	198
3.14 Wall Mounted type Indoor Unit.....	198
3.15 Super High Static Pressure Duct Type Indoor Unit.....	202
3.16 AHU-KIT Type.....	205
3.17 Concealed Floor Standing Type.....	206
3.18 360° Air Discharge Cassette Type	207
3.19 Heat Storage Module.....	208
4 Disassembly and Assembly Procedure of Main Parts.....	208

4.1 Floor Standing Type.....	208
4.2 High Static Pressure Duct Type	210
4.3 Low Static Pressure Duct Type	211
4.4 4-way Cassette Type	214
4.5 Compact 4-way Cassette Type	216
4.6 360°Air Discharge Compact Cassette Type	219
4.7 2-way Cassette Type	221
4.8 1-way Cassette Type	222
4.9 Floor Ceiling Type.....	225
4.10 Fresh air Processing Unit.....	226
4.11 Slim Duct Type.....	230
4.12 Console Type Indoor Unit	233
4.13 Wall Mounted type Indoor Unit.....	234
4.14 Super High Static Pressure Duct Type Indoor Unit.....	236
4.15 Concealed Floor Standing Type.....	238
4.16 360°Air Discharge Cassette Type	240
5 Exploded Views and Part List.....	243
5.1 Floor Standing Type.....	243
5.2 High Static Pressure Duct Type	245
5.3 Low Static Pressure Duct Type	252
5.4 4-way Cassette Type	276
5.5 Compact 4-way Cassette Type	284
5.6 360°Air Discharge Compact Cassette Type	286
5.7 2-way Cassette Type	288
5.8 1-way Cassette Type	290
5.9 Floor Ceiling Type.....	293
5.10 Fresh air Processing Unit.....	300
5.11 Slim Duct Type.....	309
5.12 Console Type Indoor Unit	318
5.13 Wall Mounted type Indoor Unit.....	320
5.14 Super High Static Pressure Duct Type Indoor Unit.....	365
5.15 AHU-KIT Type.....	380
5.16 Concealed Floor Standing Type.....	388
5.17 360°Air Discharge Cassette Type	393
5.18 Heat Storage Module.....	401

PRODUCT

1 Product List

1.1 Floor Standing Type

Model	Product Code	Cooling Capacity	Heating Capacity	Power Supply	Refrigerant	Appearance
		kW	kW			
GMV-ND100L/A-T	CM300N0060	10.0	11.0	220-240V ~50Hz 208-230V ~60Hz	R410A	
GMV-ND140L/A-T	CM300N0070	14.0	15.0			

1.2 High Static Pressure Duct Type

Model	Product Code	Cooling Capacity	Heating Capacity	Power Supply	Refrigerant	Appearance
		kW	kW			
GMV-ND56PHS/A-T	CM800N3690	5.6	6.3	220-240V ~50Hz 208-230V ~60Hz	R410A	
GMV-ND63PHS/A-T	CM800N3700	6.3	7.1			
GMV-ND71PHS/A-T	CM800N3540	7.1	8.0			
GMV-ND80PHS/A-T	CM800N3710	8.0	9.0			
GMV-ND90PHS/A-T	CM800N3550	9.0	10.0			
GMV-ND100PHS/A-T	CM800N3650	10.0	11.2			
GMV-ND112PHS/A-T	CM800N3660	11.2	12.5			
GMV-ND125PHS/A-T	CM800N3670	12.5	14.0			
GMV-ND140PHS/A-T	CM800N3680	14.0	16.0			
GMV-ND160PHS/A-T	CM810N0250	16.0	18.0			
GMV-ND224PH/A-T	CM800N3721	22.4	25.0			
GMV-ND280PH/A-T	CM800N3731	28.0	31.0			

1.3 Low Static Pressure Duct Type

Model	Product Code	Cooling Capacity	Heating Capacity	Power Supply	Refrigerant	Appearance
		kW	kW			
GMV-ND22PLS/A-T	CM800N3370	2.2	2.5	220-240 V~50Hz 208-230 V~60Hz	R410A	
GMV-ND25PLS/A-T	CM800N3380	2.5	2.8			
GMV-ND28PLS/A-T	CM800N3490	2.8	3.2			
GMV-ND32PLS/A-T	CM800N3390	3.2	3.6			
GMV-ND36PLS/A-T	CM800N3500	3.6	4.0			
GMV-ND40PLS/A-T	CM800N3400	4.0	4.5			
GMV-ND45PLS/A-T	CM800N3410	4.5	5.0			
GMV-ND50PLS/A-T	CM800N3420	5.0	5.6			
GMV-ND56PLS/A-T	CM800N3510	5.6	6.3			
GMV-ND63PLS/A-T	CM800N3430	6.3	7.1			
GMV-ND71PLS/A-T	CM800N3520	7.1	8.0			
GMV-ND80PLS/A-T	CM800N3440	8.0	9.0			
GMV-ND90PLS/A-T	CM800N3450	9.0	10.0			
GMV-ND100PLS/A-T	CM800N3460	10.0	11.2			
GMV-ND112PLS/A-T	CM800N3530	11.2	12.5			
GMV-ND125PLS/A-T	CM800N3480	12.5	14.0			

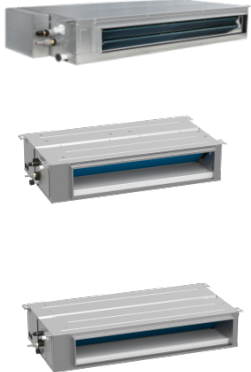
Model	Product Code	Cooling Capacity	Heating Capacity	Power Supply	Refrigerant	Appearance
		kW	kW			
GMV-ND140PLS/A-T	CM800N3470	14.0	16.0	220-240 V~50Hz 208-230 V~60Hz	R410A	
GMV-ND18PLS/C-T	CM810N2030	1.8	2.2			
GMV-ND22PLS/C-T	CM810N1800	2.2	2.5			
GMV-ND25PLS/C-T	CM810N1810	2.5	2.8			
GMV-ND28PLS/C-T	CM810N1770	2.8	3.2			
GMV-ND32PLS/C-T	CM810N1820	3.2	3.6			
GMV-ND36PLS/C-T	CM810N1760	3.6	4.0			
GMV-ND40PLS/C-T	CM810N1830	4.0	4.5			
GMV-ND45PLS/C-T	CM810N1740	4.5	5.0			
GMV-ND50PLS/C-T	CM810N1840	5.0	5.6			
GMV-ND56PLS/C-T	CM810N1850	5.6	6.3			
GMV-ND63PLS/C-T	CM810N1730	6.3	7.1			
GMV-ND71PLS/C-T	CM810N1750	7.1	8.0			
GMV-ND80PLS/C-T	CM810N1920	8.0	9.0			
GMV-ND90PLS/C-T	CM810N1960	9.0	10.0			
GMV-ND100PLS/C-T	CM810N1970	10.0	11.2			
GMV-ND112PLS/C-T	CM810N1950	11.2	12.5			
GMV-ND125PLS/C-T	CM810N1940	12.5	14.0			
GMV-ND140PLS/C-T	CM810N1930	14.0	16.0			

1.4 4-way Cassette

Model	Product Code	Cooling Capacity	Heating Capacity	Power Supply	Refrigerant	Appearance
		kW	kW			
GMV-ND28T/A-T	CM500N0380	2.8	3.2	220-240 V~50Hz 208-230 V~60Hz	R410A	
GMV-ND36T/A-T	CM500N0390	3.6	4.0			
GMV-ND45T/A-T	CM500N0400	4.5	5.0			
GMV-ND50T/A-T	CM500N0410	5.0	5.6			
GMV-ND56T/A-T	CM500N0420	5.6	6.3			
GMV-ND63T/A-T	CM500N0430	6.3	7.1			
GMV-ND71T/A-T	CM500N0440	7.1	8.0			
GMV-ND80T/A-T	CM500N0450	8.0	9.0			
GMV-ND90T/A-T	CM500N0460	9.0	10.0			
GMV-ND100T/A-T	CM500N0470	10.0	11.2			
GMV-ND112T/A-T	CM500N0480	11.2	12.5			
GMV-ND125T/A-T	CM500N0490	12.5	14.0			
GMV-ND140T/A-T	CM500N0500	14.0	16.0			
GMV-ND160T/A-T	CM500N0660	16.0	17.5			

1.5 Compact 4-way Cassette

Model	Product Code	Cooling Capacity	Heating Capacity	Power Supply	Refrigerant	Appearance
		kW	kW			
GMV-ND22T/B-T	CM500N0610	2.2	2.5	220-240V~ 50Hz 208-230V~ 60Hz	R410A	
GMV-ND28T/B-T	CM500N0620	2.8	3.2			
GMV-ND36T/B-T	CM500N0630	3.6	4.0			
GMV-ND45T/B-T	CM500N0640	4.5	5.0			
GMV-ND50T/B-T	CM500N0600	5.0	5.6			
GMV-ND56T/B-T	CM500N0650	5.6	6.3			

1.6 360° Air Discharge Compact Cassette

Model	Product Code	Cooling Capacity	Heating Capacity	Power Supply	Refrigerant	Appearance
		kW	kW			
GMV-ND15T/E-T	CM500N1690	1.5	1.8	220-240V ~50Hz 208-230V ~60Hz	R410A	
GMV-ND18T/E-T	CM500N1700	1.8	2.2			
GMV-ND22T/E-T	CM500N1350	2.2	2.5			
GMV-ND28T/E-T	CM500N1340	2.8	3.2			
GMV-ND36T/E-T	CM500N1330	3.6	4.0			
GMV-ND45T/E-T	CM500N1310	4.5	5.0			
GMV-ND50T/E-T	CM500N1320	5.0	5.6			
GMV-ND56T/E-T	CM500N1300	5.6	6.3			

1.7 2-way Cassette

Model	Product Code	Cooling Capacity	Heating Capacity	Power Supply	Refrigerant	Appearance
		kW	kW			
GMV-ND28TS/A-T	CM500N0680	2.8	3.2	220-240V~ 50Hz 208-230V~ 60Hz	R410A	
GMV-ND36TS/A-T	CM500N0690	3.6	4.0			
GMV-ND45TS/A-T	CM500N0700	4.5	5.0			
GMV-ND50TS/A-T	CM500N0710	5.0	5.6			
GMV-ND56TS/A-T	CM500N0720	5.6	6.3			
GMV-ND63TS/A-T	CM500N0730	6.3	7.1			
GMV-ND71TS/A-T	CM500N0740	7.1	8.0			



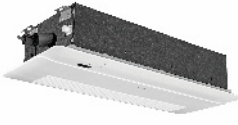

1.8 1-way Cassette

Model	Product Code	Cooling Capacity	Heating Capacity	Power Supply	Refrigerant	Appearance
		kW	kW			
GMV-ND22TD/A-T	CM502N0140	2.2	2.5	220-240V ~50Hz 208-230V ~60Hz	R410A	
GMV-ND28TD/A-T	CM502N0100	2.8	3.2			
GMV-ND36TD/A-T	CM502N0110	3.6	4.0			
GMV-ND45TD/A-T	CM502N0120	4.5	5.0			
GMV-ND50TD/A-T	CM502N0130	5.0	5.6			
GMV-ND56TD/A-T	CM502N0171	5.6	6.3			

1.9 Floor Ceiling

Model	Product Code	Cooling Capacity	Heating Capacity	Power Supply	Refrigerant	Appearance
		kW	kW			
GMV-ND28ZD/A-T	CM600N0350	2.8	3.2	220-240V ~50Hz 208-230V ~60Hz	R410A	
GMV-ND36ZD/A-T	CM600N0360	3.6	4.0			
GMV-ND50ZD/A-T	CM600N0320	5.0	5.6			
GMV-ND56ZD/A-T	CM600N0400	5.6	6.3			
GMV-ND63ZD/A-T	CM600N0410	6.3	7.1			
GMV-ND71ZD/A-T	CM600N0370	7.1	8.0			
GMV-ND90ZD/A-T	CM600N0330	9.0	10.0			
GMV-ND112ZD/A-T	CM600N0380	11.2	12.5			
GMV-ND125ZD/A-T	CM600N0390	12.5	14.0			
GMV-ND140ZD/A-T	CM600N0340	14.0	16.0			
GMV-ND160ZD/A-T	CM600N0500	16.0	18.0			

1.10 Fresh Air Processing

Model	Product Code	Cooling Capacity	Heating Capacity	Power Supply	Refrigerant	Appearance
		kW	kW			
GMV-NX140P/A(X1.2)-K	CM800N3610	14.0	10.0	220-240V ~50Hz	R410A	
GMV-NX224P/A (X2.0) -M	CM800N3620	22.4	16.0	380-415V ~50Hz	R410A	
GMV-NX280P/A (X2.5) -M	CM800N3630	28.0	20.0			
GMV-NX280P/A (X3.0) -M	CM800N3640	28.0	20.0			
GMV-NX450P/A (X4.0) -M	CM800N3740	45.0	32.0	220-240V ~50Hz & 208-230V ~60Hz	R410A	
GMV-NDX125P/A-T	CM810N1220	12.5	10.0			
GMV-NDX140P/A-T	CM810N1020	14.0	10.0			
GMV-NDX224P/A-T	CM810N0260	22.4	16.0			
GMV-NDX250P/A-T	CM810N1230	25.0	20.0			
GMV-NDX280P/A-T	CM810N0270	28.0	20.0			

1.11 Slim Duct Type

Model	Product Code	Cooling Capacity	Heating Capacity	Power Supply	Refrigerant	Appearance
		kW	kW			
GMV-ND22PL/B-T	CM800N3560	2.2	2.5	220-240V ~50Hz 208-230V ~60Hz	R410A	
GMV-ND25PL/B-T	CM810N0010	2.5	2.8			
GMV-ND28PL/B-T	CM810N0020	2.8	3.2			
GMV-ND32PL/B-T	CM800N3570	3.2	3.6			
GMV-ND36PL/B-T	CM810N0030	3.6	4.0			
GMV-ND40PL/B-T	CM800N3580	4.0	4.5			
GMV-ND45PL/B-T	CM810N0040	4.5	5.0			
GMV-ND50PL/B-T	CM810N0050	5.0	5.6			
GMV-ND56PL/B-T	CM800N3590	5.6	6.3			
GMV-ND63PL/B-T	CM810N0060	6.3	7.0			
GMV-ND72PL/B-T	CM800N3600	7.2	8.0			

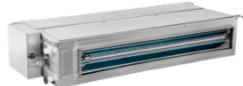
Model	Product Code	Cooling Capacity	Heating Capacity	Power Supply	Refrigerant	Appearance
		kW	kW			
GMV-ND22PLS/B1-T	CM810N1580	2.2	2.5	220-240V ~50Hz 208-230V ~60Hz	R410A	
GMV-ND25PLS/B1-T	CM810N1570	2.5	2.8			
GMV-ND28PLS/B1-T	CM810N1340	2.8	3.2			
GMV-ND32PLS/B1-T	CM810N1560	3.2	3.6			
GMV-ND36PLS/B1-T	CM810N1330	3.6	4.0			
GMV-ND40PLS/B1-T	CM810N1550	4.0	4.5			
GMV-ND45PLS/B1-T	CM810N1350	4.5	5.0			
GMV-ND50PLS/B1-T	CM810N1540	5.0	5.6			
GMV-ND56PLS/B1-T	CM810N1530	5.6	6.3			
GMV-ND63PLS/B1-T	CM810N1360	6.3	7.0			
GMV-ND71PLS/B1-T	CM810N1370	7.1	8.0			





1.12 Air Handler Type Indoor Unit



Model	Product Code	Cooling Capacity	Heating Capacity	Power Supply	Refrigerant	Appearance
		kW	kW			
GMV-NR71A/A-D	CM810N0200	7.1	8.0	208-230V ~60Hz	R410A	
GMV-NR90A/A-D	CM810N0210	9.0	10.0			
GMV-NR100A/A-D	CM810N0220	10.0	11.0			
GMV-NR112A/A-D	CM810N0230	11.2	12.5			
GMV-NR140A/A-D	CM810N0240	14.0	15.0			



1.13 Console Type Indoor Unit





Model	Product Code	Cooling Capacity	Heating Capacity	Power Supply	Refrigerant	Appearance
		kW	kW			
GMV-ND22C/A-T	CM400N0140	2.2	2.5	220-240V ~50Hz 208-230V ~60Hz	R410A	
GMV-ND28C/A-T	CM400N0070	2.8	3.2			
GMV-ND36C/A-T	CM400N0080	3.6	4.0			
GMV-ND45C/A-T	CM400N0150	4.5	5.0			
GMV-ND50C/A-T	CM400N0090	5.0	5.5			





1.14 Wall Mounted Type Indoor Unit

Model	Product Code	Cooling Capacity	Heating Capacity	Power Supply	Refrigerant	Appearance
		kW	kW			
GMV-N22G/A3A-K	CM100N1350	2.2	2.5	220-240 V~50Hz	R410A	
GMV-N28G/A3A-K	CM100N1340	2.8	3.2			
GMV-N36G/A3A-K	CM100N1360	3.6	4.0			
GMV-N45G/A3A-K	CM100N1370	4.5	5.0			
GMV-N50G/A3A-K	CM100N1330	5.0	5.8			
GMV-N56G/A3A-K	CM100N1380	5.6	6.3			
GMV-N63G/A3A-K	CM100N1390	6.3	7.0			
GMV-N71G/A3A-K	CM100N1320	7.1	7.5			
GMV-N22G/A2A-K	CM100N1690	2.2	2.5	220-240 V~50Hz	R410A	
GMV-N28G/A2A-K	CM100N1700	2.8	3.2			
GMV-N36G/A2A-K	CM100N1710	3.6	4.0			
GMV-N45G/A2A-K	CM100N1720	4.5	5.0			
GMV-N50G/A2A-K	CM100N1730	5.0	5.8			
GMV-N56G/A2A-K	CM100N1740	5.6	6.3			
GMV-N63G/A2A-K	CM100N1750	6.3	7.0			
GMV-N71G/A2A-K	CM100N1760	7.1	7.5			
GMV-N22G/A4A-K	CM100N1530	2.2	2.5	220-240 V~50Hz	R410A	
GMV-N28G/A4A-K	CM100N1540	2.8	3.2			
GMV-N36G/A4A-K	CM100N1550	3.6	4.0			
GMV-N45G/A4A-K	CM100N1560	4.5	5.0			
GMV-N50G/A4A-K	CM100N1570	5.0	5.8			
GMV-N56G/A4A-K	CM100N1580	5.6	6.3			
GMV-N63G/A4A-K	CM100N1590	6.3	7.0			
GMV-N71G/A4A-K	CM100N1600	7.1	7.5			
GMV-N22G/A8A-K	CM100N1770	2.2	2.5	220-240 V~50Hz	R410A	
GMV-N28G/A8A-K	CM100N1780	2.8	3.2			
GMV-N36G/A8A-K	CM100N1790	3.6	4.0			
GMV-N45G/A8A-K	CM100N1800	4.5	5.0			
GMV-N50G/A8A-K	CM100N1810	5.0	5.8			
GMV-N56G/A8A-K	CM100N1820	5.6	6.3			
GMV-N63G/A8A-K	CM100N1830	6.3	7.0			
GMV-N71G/A8A-K	CM100N1840	7.1	7.5			
GMV-N22G/B3A-K	CM100N2460	2.2	2.5	220-240 V~50Hz	R410A	
GMV-N28G/B3A-K	CM100N2470	2.8	3.2			
GMV-N36G/B3A-K	CM100N2480	3.6	4.0			
GMV-N45G/B3A-K	CM100N2490	4.5	5.0			
GMV-N50G/B3A-K	CM100N2500	5.0	5.8			
GMV-N56G/B3A-K	CM100N2510	5.6	6.3			
GMV-N63G/B3A-K	CM100N2520	6.3	7.0			
GMV-N71G/B3A-K	CM100N2530	7.1	7.5			

Model	Product Code	Cooling Capacity	Heating Capacity	Power Supply	Refrigerant	Appearance
		kW	kW			
GMV-N22G/C9A-K	CM100N1850	2.2	2.5	220-240 V~50Hz	R410A	
GMV-N28G/C9A-K	CM100N1860	2.8	3.2			
GMV-N36G/C9A-K	CM100N1870	3.6	4.0			
GMV-N45G/C9A-K	CM100N1880	4.5	5.0			
GMV-N50G/C9A-K	CM100N1890	5.0	5.8			
GMV-N56G/C9A-K	CM100N1900	5.6	6.3			
GMV-N63G/C9A-K	CM100N1910	6.3	7.0			
GMV-N71G/C9A-K	CM100N1920	7.1	7.5			
GMV-N22G/E3A-K	CM100N2170	2.2	2.5	220-240 V~50Hz		
GMV-N28G/E3A-K	CM100N2180	2.8	3.2			
GMV-N36G/E3A-K	CM100N2190	3.6	4.0			
GMV-N45G/E3A-K	CM100N2200	4.5	5.0			
GMV-N50G/E3A-K	CM100N2210	5.0	5.8			
GMV-N56G/E3A-K	CM100N2220	5.6	6.3			
GMV-N63G/E3A-K	CM100N2230	6.3	7.0			
GMV-N71G/E3A-K	CM100N2240	7.1	7.5			





Model	Product Code	Cooling Capacity	Heating Capacity	Power Supply	Refrigerant	Appearance
		kW	kW			
GMV-N22G/A3A-D	CM100N1430	2.2	2.5	208-230 V~60Hz	R410A	
GMV-N28G/A3A-D	CM100N1400	2.8	3.2			
GMV-N36G/A3A-D	CM100N1440	3.6	4.0			
GMV-N45G/A3A-D	CM100N1450	4.5	5.0			
GMV-N50G/A3A-D	CM100N1410	5.0	5.8			
GMV-N56G/A3A-D	CM100N1460	5.6	6.3			
GMV-N63G/A3A-D	CM100N1470	6.3	7.0			
GMV-N71G/A3A-D	CM100N1420	7.1	7.5			
GMV-N22G/A2A-D	CM100N1930	2.2	2.5	208-230 V~60Hz	R410A	
GMV-N28G/A2A-D	CM100N1940	2.8	3.2			
GMV-N36G/A2A-D	CM100N1950	3.6	4.0			
GMV-N45G/A2A-D	CM100N1960	4.5	5.0			
GMV-N50G/A2A-D	CM100N1970	5.0	5.8			
GMV-N56G/A2A-D	CM100N1980	5.6	6.3			
GMV-N63G/A2A-D	CM100N1990	6.3	7.0			
GMV-N71G/A2A-D	CM100N2000	7.1	7.5			
GMV-N22G/A4A-D	CM100N1610	2.2	2.5	208-230 V~60Hz	R410A	
GMV-N28G/A4A-D	CM100N1620	2.8	3.2			
GMV-N36G/A4A-D	CM100N1630	3.6	4.0			
GMV-N45G/A4A-D	CM100N1640	4.5	5.0			
GMV-N50G/A4A-D	CM100N1650	5.0	5.8			
GMV-N56G/A4A-D	CM100N1660	5.6	6.3			
GMV-N63G/A4A-D	CM100N1670	6.3	7.0			
GMV-N71G/A4A-D	CM100N1680	7.1	7.5			

Model	Product Code	Cooling Capacity	Heating Capacity	Power Supply	Refrigerant	Appearance
		kW	kW			
GMV-N22G/A8A-D	CM100N2010	2.2	2.5	208-230 V~60Hz	R410A	
GMV-N28G/A8A-D	CM100N2020	2.8	3.2			
GMV-N36G/A8A-D	CM100N2030	3.6	4.0			
GMV-N45G/A8A-D	CM100N2040	4.5	5.0			
GMV-N50G/A8A-D	CM100N2050	5.0	5.8			
GMV-N56G/A8A-D	CM100N2060	5.6	6.3			
GMV-N63G/A8A-D	CM100N2070	6.3	7.0			
GMV-N71G/A8A-D	CM100N2080	7.1	7.5			
GMV-N22G/C9A-D	CM100N2090	2.2	2.5			
GMV-N28G/C9A-D	CM100N2100	2.8	3.2			
GMV-N36G/C9A-D	CM100N2110	3.6	4.0			
GMV-N45G/C9A-D	CM100N2120	4.5	5.0			
GMV-N50G/C9A-D	CM100N2130	5.0	5.8			
GMV-N56G/C9A-D	CM100N2140	5.6	6.3			
GMV-N63G/C9A-D	CM100N2150	6.3	7.0			
GMV-N71G/C9A-D	CM100N2160	7.1	7.5	208-230 V~60Hz		
GMV-N22G/E3A-D	CM100N2250	2.2	2.5			
GMV-N28G/E3A-D	CM100N2260	2.8	3.2			
GMV-N36G/E3A-D	CM100N2270	3.6	4.0			
GMV-N45G/E3A-D	CM100N2280	4.5	5.0			
GMV-N50G/E3A-D	CM100N2290	5.0	5.8			
GMV-N56G/E3A-D	CM100N2300	5.6	6.3			
GMV-N63G/E3A-D	CM100N2310	6.3	7.0			
GMV-N71G/E3A-D	CM100N2320	7.1	7.5	208-230 V~60Hz		
GMV-N22G/B3A-D	CM100N2380	2.2	2.5			
GMV-N28G/B3A-D	CM100N2390	2.8	3.2			
GMV-N36G/B3A-D	CM100N2400	3.6	4.0			
GMV-N45G/B3A-D	CM100N2410	4.5	5.0			
GMV-N50G/B3A-D	CM100N2420	5.0	5.8			
GMV-N56G/B3A-D	CM100N2430	5.6	6.3			
GMV-N63G/B3A-D	CM100N2440	6.3	7.0			
GMV-N71G/B3A-D	CM100N2450	7.1	7.5	220-240 V~50Hz 208- 230V~60 Hz		
GMV-ND22G/A3A-T	CM100N2560	2.2	2.5			
GMV-ND28G/A3A-T	CM100N2600	2.8	3.2			
GMV-ND36G/A3A-T	CM100N2590	3.6	4.0			
GMV-ND45G/A3A-T	CM100N2580	4.5	5.0			
GMV-ND50G/A3A-T	CM100N2610	5.0	5.8			
GMV-ND56G/A3A-T	CM100N2570	5.6	6.3			
GMV-ND63G/A3A-T	CM100N2550	6.3	7.0			
GMV-ND71G/A3A-T	CM100N2540	7.1	7.5			
GMV-ND80G/A3A-T	CM100N2620	8.0	9.0			
GMV-ND90G/A3A-T	CM100N2630	9.0	10.0			
GMV-ND100G/A3A-T	CM100N2640	9.5	10.5			

Model	Product Code	Cooling Capacity	Heating Capacity	Power Supply	Refrigerant	Appearance
		kW	kW			
GMV-ND22G/A8A-T	CM100N2670	2.2	2.5	220-240 V~50Hz 208-230 V~60Hz	R410A	
GMV-ND28G/A8A-T	CM100N2720	2.8	3.2			
GMV-ND36G/A8A-T	CM100N2710	3.6	4.0			
GMV-ND45G/A8A-T	CM100N2650	4.5	5.0			
GMV-ND50G/A8A-T	CM100N2700	5.0	5.8			
GMV-ND56G/A8A-T	CM100N2690	5.6	6.3			
GMV-ND63G/A8A-T	CM100N2680	6.3	7.0			
GMV-ND71G/A8A-T	CM100N2660	7.1	7.5			
GMV-ND80G/A8A-T	CM100N2740	8.0	9.0			
GMV-ND90G/A8A-T	CM100N2750	9.0	10.0			
GMV-ND100G/A8A-T	CM100N2730	9.5	10.5			
GMV-ND22G/B6B-T	CM100N3240	2.2	2.5	220- 240V~50 Hz 208- 230V~60 Hz	R410A	
GMV-ND28G/ B6B-T	CM100N3270	2.8	3.2			
GMV-ND36G/ B6B-T	CM100N3210	3.6	4.0			
GMV-ND45G/ B6B-T	CM100N3250	4.5	5.0			
GMV-ND50G/ B6B-T	CM100N3200	5.0	5.6			
GMV-ND56G/ B6B-T	CM100N3260	5.6	6.3			
GMV-ND63G/ B6B-T	CM100N3230	6.3	7.1			
GMV-ND71G/ B6B-T	CM100N3220	7.1	7.5			
GMV-ND15G/B4B-T	CM100N3280	1.5	1.8	220- 240V~50 Hz 208- 230V~60 Hz	R410A	
GMV-ND18G/B4B-T	CM100N3290	1.8	2.2			
GMV-ND22G/B4B-T	CM100N2770	2.2	2.5			
GMV-ND28G/B4B-T	CM100N2780	2.8	3.2			
GMV-ND36G/B4B-T	CM100N2760	3.6	4.0			
GMV-ND45G/B4B-T	CM100N2790	4.5	5.0			
GMV-ND50G/B4B-T	CM100N2800	5.0	5.6			
GMV-ND56G/B4B-T	CM100N2810	5.6	6.3			
GMV-ND63G/B4B-T	CM100N2820	6.3	7.1			
GMV-ND71G/B4B-T	CM100N2830	7.1	7.5			
GMV-ND80G/B4B-T	CM100N2930	8.0	9.0			
GMV-ND90G/B4B-T	CM100N2940	9.0	10.0			
GMV-ND100G/B4B-T	CM100N2840	9.5	10.5			
GMV-ND22G/C4B-T	CM100N3140	2.2	2.5	220- 240V~50 Hz 208- 230V~60 Hz	R410A	
GMV-ND28G/C4B-T	CM100N3130	2.8	3.2			
GMV-ND36G/C4B-T	CM100N3150	3.6	4.0			
GMV-ND45G/C4B-T	CM100N3120	4.5	5.0			
GMV-ND50G/C4B-T	CM100N3160	5.0	5.6			
GMV-ND56G/C4B-T	CM100N3170	5.6	6.3			
GMV-ND63G/C4B-T	CM100N3180	6.3	7.1			
GMV-ND71G/C4B-T	CM100N3190	7.1	7.5			
GMV-ND22G/C2B-T	CM100N3040	2.2	2.5	220- 240V~50 Hz 208- 230V~60 Hz	R410A	
GMV-ND28G/C2B-T	CM100N3080	2.8	3.2			
GMV-ND36G/C2B-T	CM100N3050	3.6	4.0			
GMV-ND45G/C2B-T	CM100N3060	4.5	5.0			
GMV-ND50G/C2B-T	CM100N3070	5.0	5.6			
GMV-ND56G/C2B-T	CM100N3110	5.6	6.3			
GMV-ND63G/C2B-T	CM100N3100	6.3	7.1			
GMV-ND71G/C2B-T	CM100N3090	7.1	7.5			

Model	Product Code	Cooling Capacity	Heating Capacity	Power Supply	Refrigerant	Appearance
		kW	kW			
GMV-ND22G/D2B-T	CM100N2850	2.2	2.5	220-240V~50 Hz 208-230V~60 Hz	R410A	
GMV-ND28G/D2B-T	CM100N2860	2.8	3.2			
GMV-ND36G/D2B-T	CM100N2870	3.6	4.0			
GMV-ND45G/D2B-T	CM100N2880	4.5	5.0			
GMV-ND50G/D2B-T	CM100N2890	5.0	5.6			
GMV-ND56G/D2B-T	CM100N2900	5.6	6.3			
GMV-ND63G/D2B-T	CM100N2910	6.3	7.1			
GMV-ND71G/D2B-T	CM100N2920	7.1	7.5			

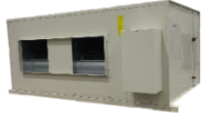

1.15 Super High Static Pressure Duct Type Indoor Unit

Model	Product Code	Cooling Capacity	Heating Capacity	Power Supply	Refrigerant	Appearance
		kW	kW			
GMV-ND22PHS/B-T	CM810N0300	2.2	2.5	220-240 V~50Hz 208-230 V~60Hz	R410A	
GMV-ND25PHS/B-T	CM810N0310	2.5	2.8			
GMV-ND28PHS/B-T	CM810N0320	2.8	3.2			
GMV-ND32PHS/B-T	CM810N0330	3.2	3.6			
GMV-ND36PHS/B-T	CM810N0340	3.6	4.0			
GMV-ND40PHS/B-T	CM810N0350	4.0	4.5			
GMV-ND45PHS/B-T	CM810N0360	4.5	5.0			
GMV-ND50PHS/B-T	CM810N0370	5.0	5.6			
GMV-ND56PHS/B-T	CM810N0380	5.6	6.3			
GMV-ND63PHS/B-T	CM810N0390	6.3	7.1			
GMV-ND71PHS/B-T	CM810N0400	7.1	8.0			
GMV-ND80PHS/B-T	CM810N0410	8.0	9.0			
GMV-ND90PHS/B-T	CM810N0420	9.0	10.0			
GMV-ND100PHS/B-T	CM810N0430	10.0	11.2			
GMV-ND112PHS/B-T	CM810N0440	11.2	12.5			
GMV-ND125PHS/B-T	CM810N0450	12.5	14.0			
GMV-ND140PHS/B-T	CM810N0460	14.0	16.0			
GMV-ND160PHS/B-T	CM810N0840	16.0	18.0			
GMV-ND180PHS/B-T	CM810N2240	18.0	20.0	380-415V 3N ~ 50/ 60Hz		
GMV-ND400PH/AR-X	CM810N1510	40.0	45.0			
GMV-ND450PH/AR-X	CM810N1520	45.0	50.0	380V 3N ~ 50Hz		
GMV-N560PH/AR-M	CM810N1610	56.0	63.0			



1.16 AHU-KIT Type

Model	Product Code	Cooling Capacity	Heating Capacity	Power Supply	Refrigerant	Appearance
		kW	kW			
GMV-N36U/A-T	CN750N0040	3.6	4.0	220-240V~50Hz 208-230V~60Hz	R410A	
GMV-N71U/A-T	CN750N0050	7.1	8.0			
GMV-N140U/A-T	CN750N0030	14.0	16.0			
GMV-N280U/A-T	CN750N0020	28.0	31.5			
GMV-N560U/A-T	CN750N0010	56.0	63.0			
GMV-N36U/B-T	CN750N0110	3.6	4.0	220-240V~50Hz 208-230V~60Hz	R410A	
GMV-N71U/B-T	CN750N0150	7.1	8.0			
GMV-N140U/B-T	CN750N0140	14.0	16.0			
GMV-N280U/B-T	CN750N0120	28.0	31.5			
GMV-N560U/B-T	CN750N0130	56.0	63.0			
GMV-N36U/C-T	CN750N0190	3.6	4.0	220-240V~50Hz 208-230V~60Hz	R410A	
GMV-N71U/C-T	CN750N0200	7.1	8.0			
GMV-N140U/C-T	CN750N0180	14.0	16.0			
GMV-N280U/C-T	CN750N0170	28.0	31.5			
GMV-N560U/C-T	CN750N0160	56.0	63.0			

1.17 Concealed Floor Standing Type

Model	Product Code	Cooling Capacity	Heating Capacity	Power Supply	Refrigerant	Appearance
		kW	kW			
GMV-ND22ZA/A-T	CM810N1490	2.2	2.5	220-240V ~50Hz 208-230V ~60Hz	R410A	
GMV-ND28ZA/A-T	CM810N1480	2.8	3.2			
GMV-ND36ZA/A-T	CM810N1460	3.6	4.0			
GMV-ND45ZA/A-T	CM810N1470	4.5	5.0			
GMV-ND56ZA/A-T	CM810N1451	5.6	6.3			
GMV-ND63ZA/A-T	CM810N1440	6.3	7.1			
GMV-ND71ZA/A-T	CM810N1430	7.1	8.0			

1.18 360° Air Discharge Cassette

Model	Product Code	Cooling Capacity	Heating Capacity	Power Supply	Refrigerant	Appearance
		kW	kW			
GMV-ND22T/C-T	CM500N1680	2.2	2.5	220-240V~50Hz 208-230V~60Hz	R410A	
GMV-ND28T/C-T	CM500N1660	2.8	3.2			
GMV-ND36T/C-T	CM500N1670	3.6	4.0			
GMV-ND45T/C-T	CM500N1650	4.5	5.0			
GMV-ND50T/C-T	CM500N1640	5.0	5.6			
GMV-ND56T/C-T	CM500N1630	5.6	6.3			
GMV-ND63T/C-T	CM500N1440	6.3	7.1			
GMV-ND71T/C-T	CM500N1370	7.1	8.0			
GMV-ND80T/C-T	CM500N1430	8.0	9.0			
GMV-ND90T/C-T	CM500N1420	9.0	10			
GMV-ND100T/C-T	CM500N1380	10	11.2			
GMV-ND112T/C-T	CM500N1400	11.2	12.5			
GMV-ND125T/C-T	CM500N1410	12.5	14			
GMV-ND140T/C-T	CM500N1360	14	16			

1.19 Heat Storage Module

Model	Product Code	Cooling Capacity	Heating Capacity	Power Supply	Refrigerant	Appearance
		kW	kW			
XRZ180L/A-T	CM810N2250	/	/	220-240V~50Hz 208-230V~60Hz	R410A	

2 Nomenclature

2.1 Nomenclature of Indoor Units

GMV	-	N	□	□	□	□	□	/	□	-	□
1		2	3	4	5	6	7		8		9

No.	Description	Options
1	Product code	GMV - Gree Multi VRF Units
2	Indoor unit code	Indoor unit - N
3	Motor type	D - DC motor NULL - AC motor
4	Function code	R - pure heat pump/ all heat exchanger with cooling function L - cooling only unit X - fresh air W - double thermal source Q - heat recovery Null - electric heating defaulted
5	Cooling capacity/air volume code	Indoor unit - nominal cooling capacity /100(W) All heat exchanger - air volume /100(m ³ /h)
6	Unit type	PL- low static pressure duct type unit; P - standard static pressure duct type unit PH - high static pressure duct type unit; PB - slim type duct type unit T - 4-way cassette unit; TX - cassette unit with small panel (4-way air supply) A - Air handler; TD - one-way cassette unit; TS - two-way cassette unit; ZD - floor ceiling unit; ZK - combine unit C - console unit; G - wall-mounted unit; L - Floor Standing unit; U - AHU-KIT unit; ZA - Concealed Floor Standing unit
7	With water pump or not	With water pump - S (S is not displayed for the cassette unit with water pump)
8	Design serial No.	Nominate by A, B, C or expand it by 1, 2, 3...
9	Power	D - 220V~,60Hz; 208-230V~,60Hz; 220-240V~,60Hz; 208/230V~,60Hz; M - 380V 3N~, 50Hz;400V 3N~,50Hz; 380-415V 3N~,50Hz; K - 220-240V~,50Hz; 230-240V~,50Hz; T - 208-230V~,60Hz & 220-240V~,50Hz

Notes:

- ① If there's "(X+figure)" at the end of model, it indicates the fresh air handler. X——fresh air; Figure (take one decimal fraction) —— air volume (m³/h) ×10-3. Eg: (X2.0).
- ② DC inverter fresh air processing indoor, airflow volume ranging from 2000m³/h to 3500m³/h are available, there's not "(X+figure)" at the end of model.

3 Specifications

3.1 Floor Standing Type

Model			GMV-ND100L/A-T	GMV-ND140L/A-T
Cooling capacity	kW		10.0	14.0
Heating capacity	kW		11.0	15.0
Circulating air volume	m ³ /h		1870	1870
Noise	dB(A)		50	50
Power supply			220-240V~50Hz 208-230V~60Hz	220-240V~50Hz 208-230V~60Hz
Rated power input	Cooling	kW	0.2	0.2
	Heating	kW	0.2	0.2
Unit Dimensions (mm)(W×D×H)			1850×580×400	
Package Dimensions (mm)(W×D×H)			2083×738×545	
Suitable climate			T1	T1
Connection pipe	Gas	mm	Φ15.9	Φ15.9
	Liquid	mm	Φ9.52	Φ9.52
	Connection Method		Bell mouth connection	Bell mouth connection
Net weight		kg	54	57

Notes:

- ① Units conform to design standard: ISO 15042-2011.
- ② Specifications may be changed due to product improvement. Please refer to nameplates of the units.
- ③ Noise data are collected from a semi-anechoic room. Decibels may be slightly higher in actual operation due to environmental change.
- ④ Above parameters are tested under the condition: high fan speed.
- ⑤ Cooling: Indoor air temperature 27°C DB/19°C WB.
- ⑥ Heating: Indoor air temperature 20°C DB/15°C WB.

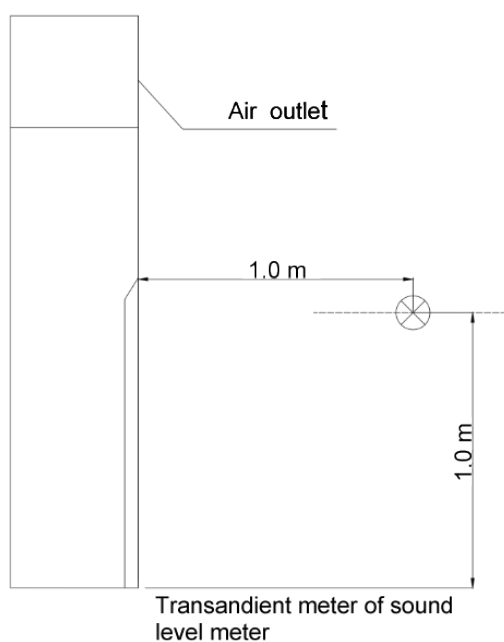

3.2 High Static Pressure Duct Type

Model		GMV-ND56P HS/A-T	GMV-ND63P HS/A-T	GMV-ND71P HS/A-T	GMV-ND80PH S/A-T	GMV-ND90PH S/A-T	GMV-ND100P HS/A-T
Cooling capacity	kW	5.6	6.3	7.1	8.0	9.0	10.0
Heating capacity	kW	6.3	7.1	8.0	9.0	10.0	11.2
Air volume	m ³ /h	1000	1000	1100	1100	1700	1700
Static pressure (Pa)	Standard	70	70	70	70	70	70
	Optional	0~100	0~100	0~100	0~100	0~100	0~100
Cooling power input	W	120	120	130	130	200	200
Cooling current input	A	0.6	0.6	0.6	0.6	1.0	1.0
Heating power input	W	120	120	130	130	200	200
Heating current input	A	0.6	0.6	0.6	0.6	1.0	1.0
Minimum line current	A	0.75	0.75	0.75	0.75	1.25	1.25
Maximum fuse current	A	6	6	6	6	6	6
Sound pressure level	dB(A)	44	44	45	45	46	46
Power supply		220-240V 1 phase ~50Hz/208-230V 1 phase ~60Hz					
Connection pipe	Liquid pipe	mm	Φ9.52	Φ9.52	Φ9.52	Φ9.52	Φ9.52
	Gas pipe	mm	Φ15.9	Φ15.9	Φ15.9	Φ15.9	Φ15.9
Drain pipe	External diameter ×thickness	mm	Φ20×1.2	Φ20×1.2	Φ20×1.2	Φ20×1.2	Φ20×1.2
Outline Dimensions (W×D×H)		mm	1271×558 ×268	1271×558 ×268	1271×558 ×268	1271×558 ×268	1229×775 ×290
Net weight		kg	35	35	35	35	47

Model		GMV-ND112 PHS/A-T	GMV-ND12 5PHS/A-T	GMV-ND14 0PHS/A-T	GMV-ND16 0PHS/A-T	GMV-ND22 4PH/A-T	GMV-ND28 0PH/A-T
Cooling capacity	kW	11.2	12.5	14.0	16.0	22.4	28.0
Heating capacity	kW	12.5	14.0	16.0	17.0	25.0	31.0
Air volume	m ³ /h	1700	2000	2000	2650	4000	4400
Static pressure (Pa)	Standard	70	70	70	70	100	100
	Optional	0~100	0~100	0~100	0~150	50~200	50~200
Cooling power input	W	200	220	220	350	800	900
Cooling current input	A	1.0	1.0	1.0	1.5	3.7	4.1
Heating power input	W	200	220	220	350	800	900
Heating current input	A	1.0	1.0	1.0	1.5	3.7	4.1
Minimum line current	A	1.25	1.25	1.25	1.875	6	6
Maximum fuse current	A	6	6	6	10	10	10
Sound pressure level	dB(A)	46	48	48	50	54	55
Power supply		220-240V 1 phase ~50Hz/208-230V 1 phase ~60Hz					
Piping interface	Liquid pipe	mm	Φ9.52	Φ9.52	Φ9.52	Φ9.52	Φ9.52
	Gas pipe	mm	Φ15.9	Φ15.9	Φ15.9	Φ19.05	Φ19.05
Drain pipe	External diameter ×thickness	mm	Φ20×1.2	Φ20×1.2	Φ20×1.2	Φ25×2	Φ25×2
Outline Dimensions (W×D×H)		mm	1229×775 ×290	1229×775 ×290	1229×775 ×290	1340×750 ×350	1483×791 ×385
Net weight		kg	47	47	47	60	82

Notes:

- ① Rated cooling capacity test conditions: indoor 27°C DB/19°C WB, outdoor 35°C DB; connection

pipe length: 5 m, without height drop between units.

- ② Rated heating capacity test conditions: indoor 20°C DB, outdoor 7°C DB/6 °C WB; connection pipe length: 5 m, without height drop between units.

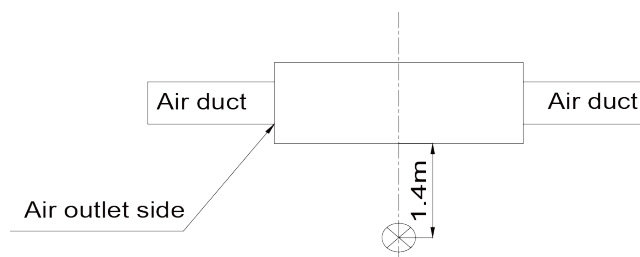

Transducer meter of sound level meter

3.3 Low Static Pressure Duct Type

Model		GMV-N D22PLS /A-T	GMV-N D25PLS /A-T	GMV-N D28PLS /A-T	GMV-N D32PLS /A-T	GMV-N D36PLS /A-T	GMV-N D40PLS /A-T	GMV-N D45PLS /A-T	GMV-N D50PLS /A-T	GMV-N D56PLS /A-T	
Cooling capacity	kW	2.2	2.5	2.8	3.2	3.6	4.0	4.5	5.0	5.6	
Heating capacity	kW	2.5	2.8	3.2	3.6	4.0	4.5	5.0	5.6	6.3	
Air Volume	m ³ /h	450	450	450	550	550	700	700	700	1000	
ESP	Pa	15/0~30	15/0~30	15/0~30	15/0~30	15/0~30	15/0~30	15/0~30	15/0~30	15/0~30	
Cooling power input	W	35	35	35	43	43	52	52	52	99	
Cooling current input	A	0.2	0.2	0.2	0.2	0.2	0.3	0.3	0.3	0.5	
Heating power input	W	35	35	35	43	43	52	52	52	99	
Heating current input	A	0.2	0.2	0.2	0.2	0.2	0.3	0.3	0.3	0.5	
Minimum line current	A	0.25	0.25	0.25	0.25	0.25	0.38	0.38	0.38	0.63	
Maximum fuse current	A	6	6	6	6	6	6	6	6	6	
Sound pressure level	dB(A)	31	31	31	32	32	33	33	33	35	
Power supply		220-240V 1 phase ~50Hz/208-230V 1 phase ~60Hz									
Pipe diameter	Liquid pipe	mm	Φ6.35	Φ6.35	Φ6.35	Φ6.35	Φ6.35	Φ6.35	Φ6.35	Φ6.35	Φ9.52
	Gas pipe	mm	Φ9.52	Φ9.52	Φ9.52	Φ12.7	Φ12.7	Φ12.7	Φ12.7	Φ12.7	Φ15.9
Drain pipe	External diameter ×thickness	mm	Φ25×2.5	Φ25×2.5	Φ25×2.5	Φ25×2.5	Φ25×2.5	Φ25×2.5	Φ25×2.5	Φ25×2.5	Φ25×2.5
Outline Dimensions	W×D×H	mm	700×615 ×200	700×615 ×200	700×615 ×200	700×615 ×200	700×615 ×200	900×615 ×200	900×615 ×200	900×615 ×200	1100×615 ×200
Net weight	kg	22	22	22	22	22	27	27	27	31	

Model		GMV-ND6 3PLS/A-T	GMV-N D71PL S/A-T	GMV-ND 80PLS/A- T	GMV-ND 90PLS/A- T	GMV-ND 100PLS/ A-T	GMV-ND 112PLS/ A-T	GMV-ND 125PLS/ A-T	GMV-ND 140PLS/ A-T
Cooling capacity	kW	6.3	7.1	8.0	9.0	10.0	11.2	12.5	14.0
Heating capacity	kW	7.1	8.0	9.0	10.0	11.2	12.5	14.0	16.0
Air volume	m ³ /h	1000	1000	1100	1500	1500	1700	2000	2000
Unit external static pressure	Pa	15/0~30	30/0~50	30/0~50	30/0~50	30/0~50	30/0~50	30/0~50	30/0~50
Cooling power input	W	99	105	140	209	209	209	230	230
Cooling current input	A	0.5	0.5	0.7	1.0	1.0	1.0	1.1	1.1
Heating power input	W	99	105	140	209	209	209	230	230

Model		GMV-ND6 3PLS/A-T	GMV-N D71PL S/A-T	GMV-ND 80PLS/A- T	GMV-ND 90PLS/A- T	GMV-ND 100PLS/ A-T	GMV-ND 112PLS/ A-T	GMV-ND 125PLS/ A-T	GMV-ND 140PLS/ A-T
Heating current input	A	0.5	0.5	0.7	1.0	1.0	1.0	1.1	1.1
Minimum line current	A	0.63	0.63	0.88	1.25	1.25	1.25	1.38	1.38
Maximum fuse current	A	6	6	6	6	6	6	6	6
Sound pressure level	dB(A)	35	35	36	40	40	40	42	42
Power supply		220-240V 1 phase ~50Hz/208-230V 1 phase ~60Hz							
Pipe diameter	Liquid pipe	mm	Φ9.52	Φ9.52	Φ9.52	Φ9.52	Φ9.52	Φ9.52	Φ9.52
	Gas pipe	mm	Φ15.9	Φ15.9	Φ15.9	Φ15.9	Φ15.9	Φ15.9	Φ15.9
Drain pipe	External diameter ×thickness	mm	Φ25×2.5	Φ25×2.5	Φ25×2.5	Φ25×2.5	Φ25×2.5	Φ25×2.5	Φ25×2.5
Outline Dimensions	W×D×H	mm	1100 ×615×200	1200 ×655×260	1200 ×655×260	1340 ×655×260	1340 ×655×260	1340 ×655×260	1340 ×655×260
Net weight		kg	31	40	40	46	46	46	47

Model		GMV-ND18PL S/C-T	GMV-ND22PL S/C-T	GMV-ND25PL S/C-T	GMV-ND28PL S/C-T	GMV-ND32PL S/C-T	GMV-ND36PL S/C-T
Cooling capacity	kW	1.8	2.2	2.5	2.8	3.2	3.6
Heating capacity	kW	2.2	2.5	2.8	3.2	3.6	4.0
Air volume	m ³ /h	450	450	450	450	550	550
Unit external static pressure	Pa	15/0~30	15/0~30	15/0~30	15/0~30	15/0~30	15/0~30
Cooling power input	W	28	28	28	28	37	37
Cooling current input	A	0.2	0.2	0.2	0.2	0.3	0.3
Heating power input	W	25	25	25	25	30	30
Heating current input	A	0.2	0.2	0.2	0.2	0.3	0.3
*Minimum line current	A	0.4	0.4	0.4	0.4	0.4	0.4
*Maximum fuse current	A	6	6	6	6	6	6
Sound pressure level	dB(A)	30	30	30	30	31	31
Power supply		220-240V 1 phase ~50Hz/208-230V 1 phase ~60Hz					
Piping interface	Liquid pipe	mm	Φ6.35	Φ6.35	Φ6.35	Φ6.35	Φ6.35
	Gas pipe	mm	Φ9.52	Φ9.52	Φ9.52	Φ9.52	Φ12.7
Drain pipe	External diameter × thickness	mm	Φ25×2.5	Φ25×2.5	Φ25×2.5	Φ25×2.5	Φ25×2.5
Dimensions	W×D×H	mm	710×462 ×200	710×462 ×200	710×462 ×200	710×462 ×200	710×462 ×200
Net weight	Main body	kg	18.5	18.5	18.5	18.5	19

Model		GMV-ND40P LS/C-T	GMV-ND45 PLS/C-T	GMV-ND50PL S/C-T	GMV-ND56 PLS/C-T	GMV-ND63P LS/C-T	GMV-ND71 PLS/C-T
Cooling capacity	kW	4.0	4.5	5.0	5.6	6.3	7.1
Heating capacity	kW	4.5	5.0	5.6	6.3	7.1	8.0
Unit external static pressure	Pa	15/0~30	15/0~30	15/0~30	15/0~30	15/0~30	15/0~50
Air volume	m ³ /h	750	750	850	850	850	1100
Cooling power input	W	40	40	55	55	55	55
Cooling current input	A	0.3	0.3	0.4	0.4	0.4	0.5
Heating power input	W	35	35	45	45	45	50

Model			GMV-ND40P LS/C-T	GMV-ND45 PLS/C-T	GMV-ND50PL S/C-T	GMV-ND56 PLS/C-T	GMV-ND63P LS/C-T	GMV-ND71 PLS/C-T
Heating current input	A		0.3	0.3	0.4	0.4	0.4	0.5
*Minimum line current	A		0.4	0.4	0.6	0.6	0.6	0.8
*Maximum fuse current	A		6	6	6	6	6	6
Sound pressure level	dB(A)		33	33	35	35	35	37
Power supply			220-240V 1 phase ~50Hz/208-230V 1 phase ~60Hz					
Piping interface	Liquid pipe	mm	Φ6.35	Φ6.35	Φ6.35	Φ9.52	Φ9.52	Φ9.52
	Gas pipe	mm	Φ12.7	Φ12.7	Φ12.7	Φ15.9	Φ15.9	Φ15.9
Drain pipe	External diameter × thickness	mm	Φ25×2.5	Φ25×2.5	Φ25×2.5	Φ25×2.5	Φ25×2.5	Φ25×2.5
Dimensions	W×D×H	mm	1010×462×200	1010×462×200	1010×462×200	1010×462×200	1010×462×200	1310×462×200
Net weight	Main body	kg	25	25	25	25	25	31

Model			GMV-ND80PL S/C-T	GMV-ND90PL S/C-T	GMV-ND100P LS/C-T	GMV-ND112P LS/C-T	GMV-ND125P LS/C-T	GMV-ND140P LS/C-T
Cooling capacity	kW		8.0	9.0	10.0	11.2	12.5	14.0
Heating capacity	kW		9.0	10.0	11.2	12.5	14.0	16.0
Air volume	m ³ /h		1250	1500	1500	1700	2000	2000
Unit external static pressure	Pa		50/0~80	50/0~80	50/0~80	50/0~80	50/0~80	50/0~80
Cooling power input	W		110	130	130	130	170	170
Cooling current input	A		0.53	0.63	0.63	0.63	0.8	0.8
Heating power input	W		110	130	130	130	170	170
Heating current input	A		0.53	0.63	0.63	0.63	0.8	0.8
Minimum line current	A		0.5	1.0	1.0	1.0	1.0	1.0
Maximum fuse current	A		0.8	1.9	1.9	1.9	1.9	1.9
Sound pressure level	dB(A)		37	40	40	40	42	42
Power supply			220-240V 1 phase ~50Hz/208-230V 1 phase ~60Hz					
Pipe diameter	Liquid pipe	mm	Φ9.52	Φ9.52	Φ9.52	Φ9.52	Φ9.52	Φ9.52
	Gas pipe	mm	Φ15.9	Φ15.9	Φ15.9	Φ15.9	Φ15.9	Φ15.9
Drain pipe	External diameter × thickness	mm	Φ25×2.5	Φ25×2.5	Φ25×2.5	Φ25×2.5	Φ25×2.5	Φ25×2.5
Dimensions	W×D×H	mm	1200×655×260	1340×655×260	1340×655×260	1340×655×260	1340×655×260	1340×655×260
Net weight	kg		39	45.5	45.5	45.5	46.5	46.5

Notes:

- ① Rated cooling capacity test conditions: indoor 27°C DB/19°C WB, outdoor 35°C DB; connection pipe length: 5m, without height drop between units.
- ② Rated heating capacity test conditions: indoor 20°C DB, outdoor 7°C DB/6 °C WB; connection pipe length: 5m, without height drop between units.
- ③ In the column of "Unit external static pressure": The figure before "/" indicates the default external static pressure of unit before delivery, and the figures after indicate the adjustable static pressure range of unit.

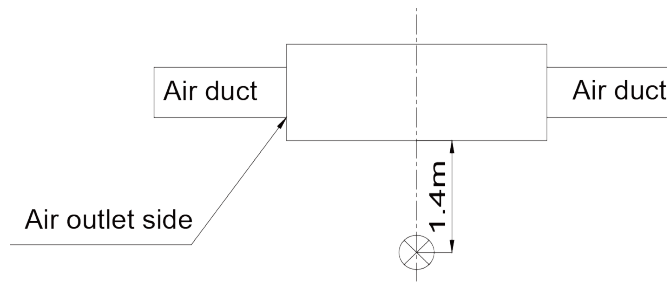

Transient meter of sound level meter

3.4 4-way Cassette Type

Model		GMV-ND28 T/A-T	GMV-ND36 T/A-T	GMV-ND45 T/A-T	GMV-ND50 T/A-T	GMV-ND56 T/A-T	GMV-ND63 T/A-T	GMV-ND71 T/A-T	
Cooling capacity	kW	2.8	3.6	4.5	5.0	5.6	6.3	7.1	
Heating capacity	kW	3.2	4.0	5.0	5.6	6.3	7.1	8.0	
Air volume	m ³ /h	750	750	750	830	1000	1000	1180	
Cooling power input	W	48	48	48	50	59	59	68	
Cooling current input	A	0.2	0.2	0.2	0.2	0.3	0.3	0.3	
Heating power input	W	48	48	48	50	59	59	68	
Heating current input	A	0.2	0.2	0.2	0.2	0.3	0.3	0.3	
Minimum line current	A	0.25	0.25	0.25	0.25	0.38	0.38	0.38	
Maximum fuse current	A	6	6	6	6	6	6	6	
Sound pressure level	dB(A)	36	36	36	36	37	37	38	
Power supply		220-240V 1 phase ~50Hz/208-230V 1 phase ~60Hz							
Piping interface	Liquid pipe	mm	Φ6.35	Φ6.35	Φ6.35	Φ6.35	Φ9.52	Φ9.52	Φ9.52
	Gas pipe	mm	Φ9.52	Φ12.7	Φ12.7	Φ12.7	Φ15.9	Φ15.9	Φ15.9
Drain pipe	External diameter×t hickness	mm	Φ25×2.5	Φ25×2.5	Φ25×2.5	Φ25×2.5	Φ25×2.5	Φ25×2.5	
Main body dimensions	W×D×H	mm	840×840 ×190	840×840 ×190	840×840 ×190	840×840 ×190	840×840 ×240	840×840 ×240	840×840 ×240
Panel dimensions	W×D×H	mm	950× 950×65	950× 950×65	950× 950×65	950× 950×65	950×950 ×65	950×950 ×65	950×950 ×65
Net weight	Main body	kg	22.5	22.5	22.5	22.5	26.5	26.5	26.5
	Panel	kg	7	7	7	7	7	7	7

Model		GMV-ND80 T/A-T	GMV-ND90 T/A-T	GMV-ND10 0T/A-T	GMV-ND11 2T/A-T	GMV-ND12 5T/A-T	GMV-ND14 0T/A-T	GMV-ND16 0T/A-T
Cooling capacity	kW	8.0	9.0	10.0	11.2	12.5	14.0	16.0
Heating capacity	kW	9.0	10.0	11.2	12.5	14.0	16.0	17.5
Air volume	m ³ /h	1180	1500	1500	1700	1860	1860	2100
Cooling power input	W	68	98	98	110	110	110	120
Cooling current input	A	0.3	0.4	0.4	0.5	0.5	0.5	0.6
Heating power input	W	68	98	98	110	110	110	120
Heating current input	A	0.3	0.4	0.4	0.5	0.5	0.5	0.6
Minimum line current	A	0.38	0.5	0.5	0.63	0.63	0.63	0.75
Maximum fuse current	A	6	6	6	6	6	6	6
Sound pressure level	dB(A)	38	40	40	41	43	43	47
Power supply		220-240V 1 phase ~50Hz/208-230V 1 phase ~60Hz						
Piping interface	Liquid pipe	mm	Φ9.52	Φ9.52	Φ9.52	Φ9.52	Φ9.52	Φ9.52
	Gas pipe	mm	Φ15.9	Φ15.9	Φ15.9	Φ15.9	Φ15.9	Φ15.9

Model			GMV-ND80 T/A-T	GMV-ND90 T/A-T	GMV-ND10 0T/A-T	GMV-ND11 2T/A-T	GMV-ND12 5T/A-T	GMV-ND14 0T/A-T	GMV-ND16 0T/A-T
Drain pipe	External diameter×thickness	mm	Φ25×2.5	Φ25×2.5	Φ25×2.5	Φ25×2.5	Φ25×2.5	Φ25×2.5	Φ25×2.5
Main body dimensions	W×D×H	mm	840×840 ×240	840×840 ×320	840×840 ×320	840×840 ×320	840×840 ×320	840×840 ×320	910×910 ×293
Panel dimensions	W×D×H	mm	950×950 ×65	950×950 ×65	950×950 ×65	950×950 ×65	950×950 ×65	950×950 ×65	1040 ×1040×65
Net weight	Main body	kg	26.5	32.5	32.5	32.5	32.5	32.5	46.5
	Panel	kg	7	7	7	7	7	7	7.5

Notes:

- ① Rated cooling capacity test conditions: indoor 27°C DB/19°C WB, outdoor 35°C DB; connection pipe length: 5 m, without height drop between units.
- ② Rated heating capacity test conditions: indoor 20°C DB, outdoor 7°C DB/6 °C WB; connection pipe length: 5 m, without height drop between units.

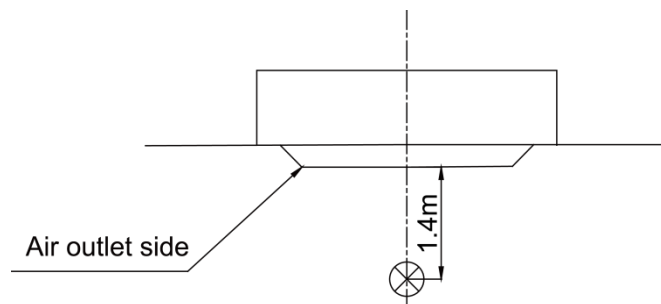

Transient meter of sound level meter

3.5 Compact 4-way Cassette Type

Model			GMV-ND22T/ B-T	GMV-ND28T/ B-T	GMV-ND36T/ B-T	GMV-ND45T/ B-T	GMV-ND50T/ B-T	GMV-ND56T/ B-T
Cooling capacity	kW		2.2	2.8	3.6	4.5	5.0	5.6
Heating capacity	kW		2.5	3.2	4.0	5.0	5.6	6.3
Air volume	m ³ /h		600	600	600	700	700	700
Cooling power input	W		35	35	35	45	45	45
Cooling current input	A		0.4	0.4	0.4	0.5	0.5	0.5
Heating power input	W		35	35	35	45	45	45
Heating current input	A		0.4	0.4	0.4	0.5	0.5	0.5
Minimum line current	A		0.5	0.5	0.5	0.63	0.63	0.63
Maximum fuse current	A		6	6	6	6	6	6
Sound pressure level	dB(A)		41	41	41	45	45	45
Power supply			220-240V 1 phase ~50Hz/208-230V 1 phase ~60Hz					
Piping interface	Liquid pipe	mm	Φ6.35	Φ6.35	Φ6.35	Φ6.35	Φ6.35	Φ9.52
	Gas pipe	mm	Φ9.52	Φ9.52	Φ12.7	Φ12.7	Φ12.7	Φ15.9
Drain pipe	External diameter×Thickness	mm	Φ25×2.5	Φ25×2.5	Φ25×2.5	Φ25×2.5	Φ25×2.5	Φ25×2.5
Main body dimensions	W×D×H	mm	596×596×240	596×596×240	596×596×240	596×596×240	596×596×240	596×596×240
Panel dimensions	W×D×H	mm	670×670×50	670×670×50	670×670×50	670×670×50	670×670×50	670×670×50
Net weight	Main body	kg	20.5	20.5	20.5	20.5	20.5	20.5
	Panel	kg	3.5	3.5	3.5	3.5	3.5	3.5

Notes:

- ① Rated cooling capacity test conditions: indoor 27°C DB/19°C WB, outdoor 35°C DB; connection pipe length: 5 m, without height drop between units.
- ② Rated heating capacity test conditions: indoor 20°C DB, outdoor 7°C DB/6 °C WB; connection pipe length: 5 m, without height drop between units.

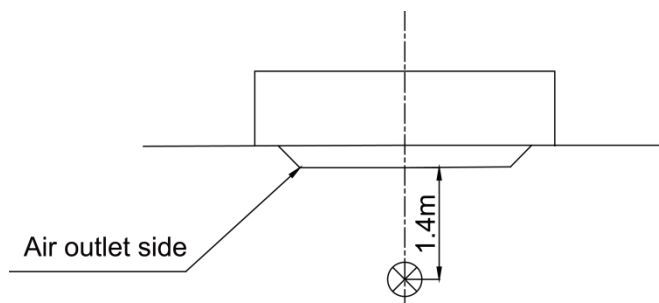

Transient meter of sound level meter

3.6 360° Air Discharge Compact Cassette

Model		GMV-ND15	GMV-ND18	GMV-ND22	GMV-ND28	GMV-ND36	GMV-ND45	GMV-ND50	GMV-ND56	
		T/E-T	T/E-T	T/E-T	T/E-T	T/E-T	T/E-T	T/E-T	T/E-T	
Cooling capacity	kW	1.5	1.8	2.2	2.8	3.6	4.5	5.0	5.6	
Heating capacity	kW	1.8	2.2	2.5	3.2	4.0	5.0	5.6	6.3	
Air volume(H/M/L)	m ³ /h	460/420/ 370	460/420/ 370	500/460/ 370	570/480/ 420	620/550/ 480	730/650/ 560	730/650/ 560	730/650/ 560	
Cooling power input	W	30	30	30	30	30	45	45	45	
Cooling current input	A	0.15	0.15	0.15	0.15	0.15	0.23	0.23	0.23	
Heating power input	W	30	30	30	30	30	45	45	45	
Heating current input	A	0.15	0.15	0.15	0.15	0.15	0.23	0.23	0.23	
Minimum line current	A	0.2	0.2	0.2	0.2	0.2	0.3	0.3	0.3	
Maximum fuse current	A	6	6	6	6	6	6	6	6	
Sound pressure level(H/M/L)	dB(A)	33/30/25	33/30/25	36/31/25	36/33/28	39/37/35	43/41/39	43/41/39	43/41/39	
Power supply		220-240V 1 phase ~50Hz/208-230V 1 phase ~60Hz								
Piping interface	Liquid pipe	mm	Φ6.35	Φ6.35	Φ6.35	Φ6.35	Φ6.35	Φ6.35	Φ6.35	Φ9.52
	Gas pipe	mm	Φ9.52	Φ9.52	Φ9.52	Φ9.52	Φ12.7	Φ12.7	Φ12.7	Φ15.9
Drain pipe	External diameter ×thickness	mm	Φ25×2.5	Φ25×2.5	Φ25×2.5	Φ25×2.5	Φ25×2.5	Φ25×2.5	Φ25×2.5	Φ25×2.5
Main body dimensions	W×D×H	mm	570×570 ×265	570×570 ×265	570×570 ×265	570×570 ×265	570×570 ×265	570×570 ×265	570×570 ×265	570×570 ×265
Panel dimensions	W×D×H	mm	620×620 ×47.5	620×620 ×47.5	620×620 ×47.5	620×620 ×47.5	620×620 ×47.5	620×620 ×47.5	620×620 ×47.5	620×620 ×47.5
Net weight	Main body	kg	17.5	17.5	17.5	17.5	17.5	17.5	17.5	17.5
	Panel	kg	3	3	3	3	3	3	3	3

Notes:

- ① Rated cooling capacity test conditions: indoor 27°C DB/19°C WB, outdoor 35°C DB; connection pipe length: 5 m, without height drop between units.
- ② Rated heating capacity test conditions: indoor 20°C DB, outdoor 7°C DB/6 °C WB; connection pipe length: 5 m, without height drop between units.

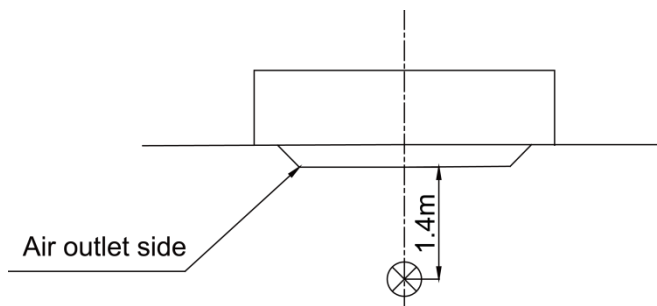

Transducer of sound level meter

3.7 2-way Cassette Type

Model		GMV-ND 28TS/AT	GMV-ND 36TS/A-T	GMV-ND 45TS/A-T	GMV-ND 50TS/A-T	GMV-ND 56TS/A-T	GMV-ND 63TS/A-T	GMV-ND 71TS/A-T	
Cooling capacity	kW	2.8	3.6	4.5	5.0	5.6	6.3	7.1	
Heating capacity	kW	3.2	4.0	5.0	5.6	6.3	7.1	8.0	
Air volume	m ³ /h	830	830	830	830	1100	1100	1100	
Cooling power input	W	55	55	55	55	103	103	103	
Cooling current input	A	0.4	0.4	0.4	0.4	0.7	0.7	0.7	
Heating power input	W	55	55	55	55	103	103	103	
Heating current input	A	0.4	0.4	0.4	0.4	0.7	0.7	0.7	
Minimum line current	A	0.5	0.5	0.5	0.5	0.9	0.9	0.9	
Maximum fuse current	A	6	6	6	6	6	6	6	
Sound pressure level	dB(A)	35	35	35	35	39	39	39	
Power supply		220-240V 1 phase ~50Hz/208-230V 1 phase ~60Hz							
Piping interface	Liquid pipe	mm	Φ6.35	Φ6.35	Φ6.35	Φ6.35	Φ9.52	Φ9.52	Φ9.52
	Gas pipe	mm	Φ9.52	Φ12.7	Φ12.7	Φ12.7	Φ15.9	Φ15.9	Φ15.9
Drain pipe	External diameter × Thickness	mm	Φ25×2.5	Φ25×2.5	Φ25×2.5	Φ25×2.5	Φ25×2.5	Φ25×2.5	Φ25×2.5
Main body dimensions	W×D×H	mm	1200×520×315	1200×520×315	1200×520×315	1200×520×315	1200×520×315	1200×520×315	1200×520×315
Panel dimensions	W×D×H	mm	1416×630×33	1416×630×33	1416×630×33	1416×630×33	1416×630×33	1416×630×33	1416×630×33
Net weight	Main body	kg	43.0	43.0	43.0	43.0	46.0	46.0	46.0
	Panel	kg	7.0	7.0	7.0	7.0	7.0	7.0	7.0

Notes:

- ① Rated cooling capacity test conditions: indoor 27°C DB/19°C WB, outdoor 35°C DB; connection pipe length: 5 m, without height drop between units.
- ② Rated heating capacity test conditions: indoor 20°C DB, outdoor 7°C DB/6 °C WB; connection pipe length: 5 m, without height drop between units.

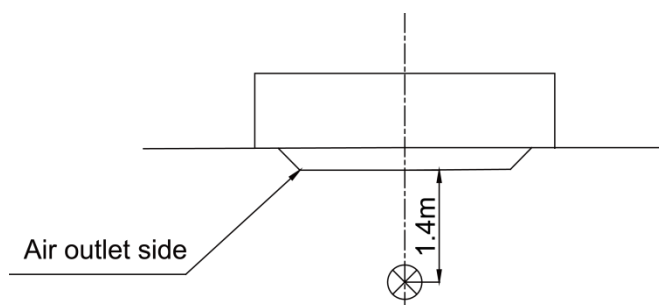

Transducer of sound level meter

3.8 1-way Cassette Type

Model		GMV-ND22 TD/A-T	GMV-ND28 TD/A-T	GMV-ND36 TD/A-T	GMV-ND45 TD/A-T	GMV-ND50 TD/A-T	GMV-ND56 TD/A-T	
Cooling capacity	kW	2.2	2.8	3.6	4.5	5.0	5.6	
Heating capacity	kW	2.5	3.2	4.0	5.0	5.6	6.3	
Air volume	m ³ /h	600	600	600	830	830	890	
Cooling power input	W	30	30	30	45	45	45	
Cooling current input	A	0.2	0.2	0.2	0.3	0.3	0.3	
Heating power input	W	30	30	30	45	45	45	
Heating current input	A	0.2	0.2	0.2	0.3	0.3	0.3	
Minimum line current	A	0.25	0.25	0.25	0.38	0.38	0.38	
Maximum fuse current	A	6	6	6	6	6	6	
Sound pressure level	dB(A)	36	36	36	40	40	41	
Power supply		220-240V 1 phase ~50Hz/208-230V 1 phase ~60Hz						
Piping interface	Liquid pipe	mm	Φ6.35	Φ6.35	Φ6.35	Φ6.35	Φ6.35	Φ9.52
	Gas pipe	mm	Φ9.52	Φ9.52	Φ12.7	Φ12.7	Φ12.7	Φ15.9
Drain pipe	External diameter ×thickness	mm	Φ25×2.5	Φ25×2.5	Φ25×2.5	Φ25×2.5	Φ25×2.5	Φ25×2.5
Main body dimensions	W×D×H	mm	987×385×178	987×385×178	987×385×178	987×385×178	987×385×178	987×385×178
Panel dimensions	W×D×H	mm	1200×460×55	1200×460×55	1200×460×55	1200×460×55	1200×460×55	1200×460×55
Net weight	Main body	kg	20	20	20	21	21	21
	Panel	kg	4.2	4.2	4.2	4.2	4.2	4.2

Notes:

- ① Rated cooling capacity test conditions: indoor 27°C DB/19°C WB, outdoor 35°C DB; connection pipe length: 5 m, without height drop between units.
- ② Rated heating capacity test conditions: indoor 20°C DB, outdoor 7°C DB/6 °C WB; connection pipe length: 5 m, without height drop between units.

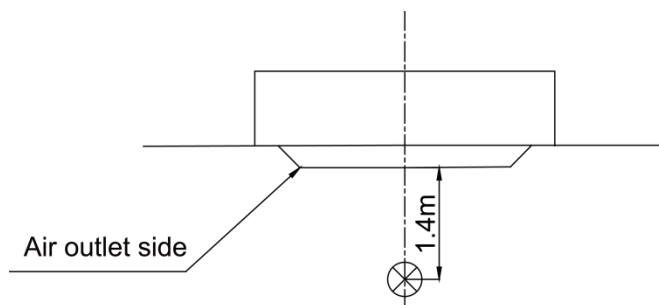

Transient meter of sound level meter

3.9 Floor Ceiling Type

Model		GMV-ND28 ZD/A-T	GMV-ND36 ZD/A-T	GMV-ND50 ZD/A-T	GMV-ND56 ZD/A-T	GMV-ND63 ZD/A-T	GMV-ND71 ZD/A-T
Cooling capacity	kW	2.8	3.6	5.0	5.6	6.3	7.1
Heating capacity	kW	3.2	4.0	5.6	6.3	7.1	8.0
Air volume	m ³ /h	650	650	950	950	1400	1400
Cooling power input	W	40	40	50	50	75	75
Cooling current input	A	0.3	0.3	0.4	0.4	0.6	0.6
Heating power input	W	40	40	50	50	75	75
Heating current input	A	0.3	0.3	0.4	0.4	0.6	0.6

Model		GMV-ND28 ZD/A-T	GMV-ND36 ZD/A-T	GMV-ND50 ZD/A-T	GMV-ND56 ZD/A-T	GMV-ND63 ZD/A-T	GMV-ND71 ZD/A-T
Minimum line current	A	0.32	0.32	0.43	0.43	0.64	0.64
Maximum fuse current	A	6	6	6	6	6	6
Sound pressure level	dB(A)	36	36	42	42	44	44
Power supply		220-240V 1 phase ~50Hz/208-230V 1 phase ~60Hz					
Piping interface	Liquid pipe	mm	Φ6.35	Φ6.35	Φ6.35	Φ9.52	Φ9.52
	Gas pipe	mm	Φ9.52	Φ12.7	Φ12.7	Φ15.9	Φ15.9
Drain pipe	External diameter ×thickness	mm	Φ17×1.75	Φ17×1.75	Φ17×1.75	Φ17×1.75	Φ17×1.75
Outline Dimensions	W×D×H	mm	1220×700×225	1220×700×225	1220×700×225	1220×700×225	1420×700×245
Net weight	kg	40	40	40	40	50	50

Model		GMV-ND90 ZD/A-T	GMV-ND112 ZD/A-T	GMV-ND125 ZD/A-T	GMV-ND140 ZD/A-T	GMV-ND160 ZD/A-T
Cooling capacity	kW	9.0	11.2	12.5	14.0	16.0
Heating capacity	kW	10.0	12.5	14.0	16.0	18.0
Air volume	m ³ /h	1600	2000	2000	2000	2300
Cooling power input	W	140	160	160	160	200
Cooling current input	A	1.1	1.4	1.4	1.4	1.9
Heating power input	W	140	160	160	160	200
Heating current input	A	1.1	1.4	1.4	1.4	1.9
Minimum line current	A	1.17	1.5	1.5	1.5	2
Maximum fuse current	A	6	6	6	6	6
Sound pressure level	dB(A)	50	51	52	52	52
Power supply		220-240V 1 phase ~50Hz/208-230V 1 phase ~60Hz				
Piping interface	Liquid pipe	mm	Φ9.52	Φ9.52	Φ9.52	Φ9.52
	Gas pipe	mm	Φ15.9	Φ15.9	Φ15.9	Φ19.05
Drain pipe	External diameter ×thickness	mm	Φ17×1.75	Φ17×1.75	Φ17×1.75	Φ17×1.75
Outline Dimensions	W×D×H	mm	1420×700×245	1700×700×245	1700×700×245	1700×700×245
Net weight	kg	50	60	60	60	60

Notes:

- ① Rated Cooling capacity test conditions: indoor 27°C DB/19°C WB, outdoor 35°C DB; connection pipe length: 5 m, without height drop between units.
- ② Rated heating capacity test conditions: indoor 20°C DB, outdoor 7°C DB/6 °C WB; connection pipe length: 5 m, without height drop between units.

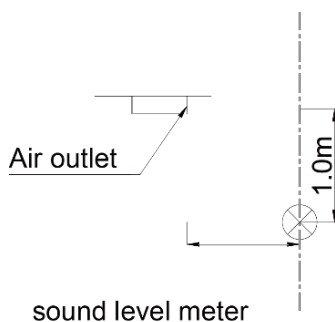

3.10 Fresh air Processing Unit

AC Inverter Fresh Air Processing Indoor

Model		GMV-NX140 P/A(X1.2)-K	GMV-NX224 P/A(X2.0) -M	GMV-NX280 P/A(X2.5) -M	GMV-NX280 P/A(X3.0) -M	GMV-NX450 P/A(X4.0) -M
Cooling capacity	kW	14	22.4	28	28	45
Heating capacity	kW	10	16	20	20	32
Air volume	m ³ /h	1200	2000	2500	3000	4000
Cooling power input	W	360	740	760	1060	1240
Static pressure (Pa)	Standard	150	200	200	200	200
	Optional	200	300	300	300	300
Cooling current input	A	1.65	2.10	2.40	2.47	3.40
Heating power input	W	360	740	760	1060	1240
Heating current input	A	1.65	2.10	2.40	2.47	3.40
Minimum line current	A	2.1	2.6	3.0	3.1	4.3
Maximum fuse current	A	3.7	4.7	5.4	5.5	7.6
Sound pressure level	dB(A)	42	47	48	51	58
Power supply		220-240V 1phase~50Hz	380-415V 3N~50Hz	380-415V 3N~50Hz	380-415V 3N~50Hz	380-415V 3N~50Hz
Piping interface	Liquid pipe	mm	Φ9.52	Φ9.52	Φ9.52	Φ9.52
	Gas pipe	mm	Φ15.9	Φ19.05	Φ22.2	Φ22.2
Drain pipe	External diameter ×thickness	mm	Φ30×1.5	Φ30×1.5	Φ30×1.5	Φ33×3.0
Outline Dimensions	W×D×H	mm	1463×756 ×300	1500×1000 ×500	1500×1000 ×500	1500×1000 ×500
Net weight		kg	63.5	130	134	134

Notes:

- ① Rated cooling capacity test conditions: fresh air inlet 35°C DB/28°C WB; connection pipe length: 5 m, without height drop between units; the default air outlet temperature of the unit is 18°C.
- ② Rated heating capacity test conditions: fresh air inlet 7°C DB/6°C WB; connection pipe length: 5 m, without height drop between units; the default air outlet temperature of the unit is 22°C.

DC Inverter Fresh Air Processing Indoor

Model		GMV-NDX125P/A-T	GMV-NDX140P/A-T	GMV-NDX224P/A-T
Cooling capacity	kW	12.5	14.0	22.4
Heating capacity	kW*1	8.5	10.0	16.0
	kW*2	10.5	12.0	20.0
Air volume	m ³ /h	1200/1000~2000	1200/1000~2000	2000/1500~3000
Static pressure (Pa)	Standard	150	150	200
	Optional	50~200	50~200	50~300
Rated power input	W	350	350	760
Rated current input	A	2.0	2.0	4.3
Cooling power input	W	200	200	400
Cooling current input	A	1.5	1.5	2.5
Heating power input	W	200	200	400
Heating current input	A	1.5	1.5	2.5
Maximum fuse current	A	6	6	10
Sound pressure level	dB(A)	40~50	40~50	45~54
Power supply		220-240V 1 phase ~50Hz 208-230V 1 phase ~60Hz		

Model			GMV-NDX125P/A-T	GMV-NDX140P/A-T	GMV-NDX224P/A-T
Piping diameter	Liquid pie	mm	Φ9.52	Φ9.52	Φ9.52
	Gas pipe	mm	Φ15.9	Φ15.9	Φ19.05
Drain pipe	Outer diameter ×Wall thickness	mm	Φ25×2.5	Φ25×2.5	Φ25×2
Outline Dimensions	W×D×H	mm	1400×700×300	1400×700×300	1483×791×385
Net weight		kg	54	54	82

Model			GMV-NDX250P/A-T	GMV-NDX280P/A-T
Cooling capacity	kW		25.0	28.0
Heating capacity	kW*1		18.0	20.0
	kW*2		20.0	22.0
Air volume	m ³ /h		2500/2000~3500	2500/2000~3500
Static pressure (Pa)	Standard		200	200
	Optional		50~300	50~300
Rated power input	W		860	860
Rated current input	A		4.9	4.9
Cooling power input	W		520	520
Cooling current input	A		3.1	3.1
Heating power input	W		520	520
Heating current input	A		3.1	3.1
Maximum fuse current	A		10	10
Sound pressure level	dB(A)		47~54	47~54
Power supply			220-240V 1 phase ~50Hz 208-230V 1 phase ~60Hz	
Piping diameter	Liquid pie	mm	Φ9.52	Φ9.52
	Gas pipe	mm	Φ22.2	Φ22.2
Drain pipe	Outer diameter ×Wall thickness	mm	Φ25×2	Φ25×2
Outline Dimensions	W×D×H	mm	1483×791×385	1483×791×385
Net weight		kg	82	82

Notes:

- ① Rated cooling capacity test conditions: indoor 35°C DB/28°C WB, outdoor 35°C DB; connection pipe length: 7.5m, without height drop between units. The default air outlet temperature of the unit is 18°C.
- ② Rated heating capacity test conditions: *1: indoor 7°C DB, outdoor 7°C DB/6 °C WB, *2: indoor 0°C DB, outdoor 0°C DB/RH80%; connection pipe length: 7.5m, without height drop between units. The default air outlet temperature of the unit is 22°C.
- ③ In the column of "Air Volume": The figure before "/" indicates the default air Volume of unit before delivery, and the figures after indicate the adjustable air Volume range of unit.
- ④ The noise value marked in the nameplate is tested under rated condition. For the units of GMV-NDX125P/A-T and GMV-NDX140P/A-T, which are defaulted as speed 08 under static pressure of 150Pa. And others are defaulted as speed 08 under static pressure of 200Pa. The noise in the highest speed may increase by about 3 dB(A) on this value. The noise in the lowest speed may decrease by about 5 dB(A) on this value. The recorded noise value of the sample unit is tested in semi-anechoic room. Under actual installation, the noise value is usually higher than the recorded value of the sample due to the influence of ambient noise and reflected

sound.

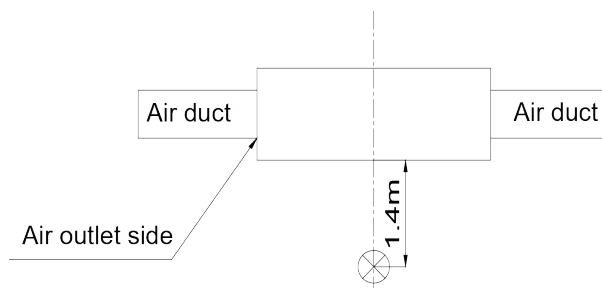

Transducer of sound level meter

3.11 Slim Duct Type

Model		GMV-ND22 PL/B-T	GMV-ND25 PL/B-T	GMV-ND28 PL/B-T	GMV-ND32 PL/B-T	GMV-ND36 PL/B-T	GMV-ND40 PL/B-T
Cooling capacity	kW	2.2	2.5	2.8	3.2	3.6	4.0
Heating capacity	kW	2.5	2.8	3.2	3.6	4.0	4.5
Air volume	m ³ /h	450	450	450	550	550	750
Unit external static pressure	Pa	0/0~15	0/0~15	0/0~15	0/0~15	0/0~15	0/0~15
Cooling power input	W	25	25	25	30	30	35
Cooling current input	A	0.2	0.2	0.2	0.3	0.3	0.3
Heating power input	W	25	25	25	30	30	35
Heating current input	A	0.2	0.2	0.2	0.3	0.3	0.3
*Minimum line current	A	0.25	0.25	0.25	0.38	0.38	0.38
*Maximum fuse current	A	6	6	6	6	6	6
Sound pressure level	dB(A)	30	30	30	31	31	33
Power supply		220-240V 1 phase ~50Hz/208-230V 1 phase ~60Hz					
Piping interface	Liquid pipe	mm	Φ6.35	Φ6.35	Φ6.35	Φ6.35	Φ6.35
	Gas pipe	mm	Φ9.52	Φ9.52	Φ9.52	Φ12.7	Φ12.7
Drain pipe	External diameter × thickness	mm	Φ25×2.5	Φ25×2.5	Φ25×2.5	Φ25×2.5	Φ25×2.5
Dimensions	W×D×H	mm	710×450 ×200	710×450 ×200	710×450 ×200	710×450 ×200	1010×450 ×200
Net weight	Main body	kg	18.5	18.5	18.5	19.5	19.5

Model		GMV-ND45PL /B-T	GMV-ND50PL /B-T	GMV-ND56PL /B-T	GMV-ND63PL /B-T	GMV-ND72PL /B-T
Cooling capacity	kW	4.5	5.0	5.6	6.3	7.2
Heating capacity	kW	5.0	5.6	6.3	7.0	8.0
Unit external static pressure	Pa	0/0~15	0/0~15	0/0~15	0/0~15	0/0~15
Air volume	m ³ /h	750	750	850	850	1100
Cooling power input	W	35	35	45	45	50
Cooling current input	A	0.3	0.3	0.3	0.3	0.5
Heating power input	W	35	35	45	45	50
Heating current input	A	0.3	0.3	0.3	0.3	0.5
*Minimum line current	A	0.38	0.38	0.38	0.38	0.63
*Maximum fuse current	A	6	6	6	6	6
Sound pressure level	dB(A)	33	33	35	35	37
Power supply		220-240V 1 phase ~50Hz/208-230V 1 phase ~60Hz				

Model			GMV-ND45PL /B-T	GMV-ND50PL /B-T	GMV-ND56PL /B-T	GMV-ND63PL /B-T	GMV-ND72PL /B-T
Piping interface	Liquid pipe	mm	Φ6.35	Φ6.35	Φ9.52	Φ9.52	Φ9.52
	Gas pipe	mm	Φ12.7	Φ12.7	Φ15.9	Φ15.9	Φ15.9
Drain pipe	External diameter × thickness	mm	Φ25×2.5	Φ25×2.5	Φ25×2.5	Φ25×2.5	Φ25×2.5
Dimensions	W×D×H	mm	1010×450×200	1010×450×200	1010×450×200	1010×450×200	1310×450×200
Net weight	Main body	kg	23.5	23.5	24.5	24.5	30.5

Model			GMV-ND22 PLS/B1-T	GMV-ND25 PLS/B1-T	GMV-ND28 PLS/B1-T	GMV-ND32 PLS/B1-T	GMV-ND36 PLS/B1-T	GMV-ND40 PLS/B1-T	
Cooling capacity	kW		2.2	2.5	2.8	3.2	3.6	4.0	
Heating capacity	kW		2.5	2.8	3.2	3.6	4.0	4.5	
Air volume	m ³ /h		610	610	610	620	650	810	
Unit external static pressure	Pa		10/30	10/30	10/30	10/30	10/30	10/30	
Cooling power input	W		65	65	65	65	65	65	
Cooling current input	A		0.30	0.30	0.30	0.30	0.30	0.30	
Heating power input	W		65	65	65	65	65	65	
Heating current input	A		0.30	0.30	0.30	0.30	0.30	0.30	
*Minimum line current	A		0.63	0.63	0.63	0.63	0.63	0.63	
*Maximum fuse current	A		1.1	1.1	1.1	1.1	1.1	1.1	
Sound pressure level	dB(A)		38	38	38	38	38	37	
Power supply			220-240V 1 phase ~50Hz/208-230V 1 phase ~60Hz						
Piping interface	Liquid pipe	mm	Φ6.35	Φ6.35	Φ6.35	Φ6.35	Φ6.35	Φ6.35	
	Gas pipe	mm	Φ9.52	Φ9.52	Φ9.52	Φ12.7	Φ12.7	Φ12.7	
Drain pipe	External diameter × thickness	mm	Φ25×2.5	Φ25×2.5	Φ25×2.5	Φ25×2.5	Φ25×2.5	Φ25×2.5	
Dimensions	W×D×H	mm	710×450 ×200	710×450 ×200	710×450 ×200	710×450 ×200	710×450 ×200	1010×450 ×200	
Net weight	Main body	kg	19.0	19.0	19.0	20.0	20.0	24.0	

Model			GMV-ND45PL S/B1-T	GMV-ND50PL S/B1-T	GMV-ND56PL S/B1-T	GMV-ND63PL S/B1-T	GMV-ND71PL S/B1-T	
Cooling capacity	kW		4.5	5.0	5.6	6.3	7.1	
Heating capacity	kW		5.0	5.6	6.3	7.0	8.0	
Air volume	m ³ /h		810	810	810	810	1210	
Unit external static pressure	Pa		10/30	10/30	10/30	10/30	10/30	
Cooling power input	W		65	65	65	65	70	
Cooling current input	A		0.30	0.30	0.30	0.30	0.32	
Heating power input	W		65	65	65	65	70	
Heating current input	A		0.30	0.30	0.30	0.30	0.32	
*Minimum line current	A		0.63	0.63	0.63	0.63	0.63	
*Maximum fuse current	A		1.1	1.1	1.1	1.1	1.1	
Sound pressure level	dB(A)		37	37	37	37	39	
Power supply			220-240V 1 phase ~50Hz/208-230V 1 phase ~60Hz					
Piping interface	Liquid pipe	mm	Φ6.35	Φ6.35	Φ9.52	Φ9.52	Φ9.52	
	Gas pipe	mm	Φ12.7	Φ12.7	Φ15.9	Φ15.9	Φ15.9	
Drain pipe	External diameter × thickness	mm	Φ25×2.5	Φ25×2.5	Φ25×2.5	Φ25×2.5	Φ25×2.5	

Model			GMV-ND45PL S/B1-T	GMV-ND50PL S/B1-T	GMV-ND56PL S/B1-T	GMV-ND63PL S/B1-T	GMV-ND71PL S/B1-T
Dimensions	W×D×H	mm	1010×450×200	1010×450×200	1010×450×200	1010×450×200	1310×450×200
Net weight	Main body	kg	24.0	25.0	25.0	25.0	30.5

Notes:

- ① Rated cooling capacity test conditions: indoor 27°C DB/19°C WB, outdoor 35°C DB; connection pipe length: 5 m, without height drop between units.
- ② Rated heating capacity test conditions: indoor 20°C DB, outdoor 7°C DB/6 °C WB; connection pipe length: 5 m, without height drop between units.
- ③ In the column of “Unit external static pressure”: The figure before “/” indicates the default external static pressure of unit before delivery, and the figures after indicate the adjustable static pressure range of unit.

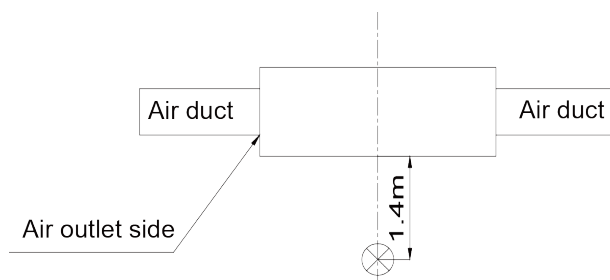

Transducer of sound level meter

3.12 Air Handler Type Indoor Unit

Model			GMV-NR71A/ A-D	GMV-NR90A/ A-D	GMV-NR100A /A-D	GMV-NR112A /A-D	GMV-NR140A /A-D
Cooling capacity	kW		7.1	9.0	10.0	11.2	14.0
Heating capacity	kW		8.0	10.0	11.0	12.5	15.0
Air volume	m ³ /h		1600	1700	1900	2300	2500
Cooling power input	W		215	270	370	430	550
Cooling current input	A		1.10	1.35	2.00	2.00	2.50
Heating power input	W		215	270	370	430	550
Heating current input	A		1.10	1.35	2.00	2.00	2.50
Minimum line current	A		0.4	0.4	0.4	0.5	0.5
Maximum fuse current	A		6	6	6	6	6
Sound pressure level	dB(A)		50	51	52	52	55
Power supply			208-230V 1 phase ~60Hz				
Piping interface	Liquid pipe	mm	Φ9.52	Φ9.52	Φ9.52	Φ9.52	Φ9.52
	Gas pipe	mm	Φ15.9	Φ15.9	Φ15.9	Φ15.9	Φ15.9
Drain pipe		mm	G1	G1	G1	G1	G1
Main body dimensions	W×D×H	mm	460×540×1105	460×540×1105	540×540×1224	540×540×1224	630×540×1224
Panel dimensions	W×D×H	mm	517×620×1170	517×620×1170	597×620×1289	597×620×1289	687×621×1295
Net weight	Main body	kg	54	57	66	68	78

Notes:

- ① Rated cooling capacity test conditions: indoor 27°C DB/19°C WB, outdoor 35°C DB; connection pipe length: 5 m, without height drop between units.
- ② Rated heating capacity test conditions: indoor 20°C DB, outdoor 7°C DB/6 °C WB; connection pipe length: 5 m, without height drop between units.

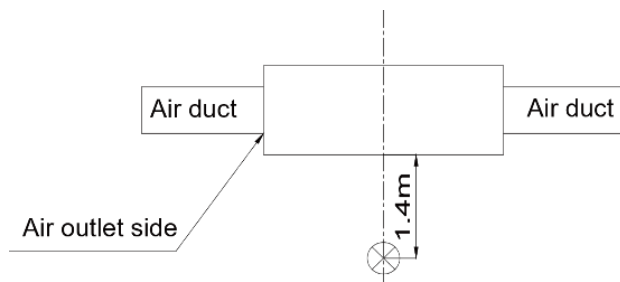

Transient meter of sound level meter

3.13 Console Type Indoor Unit

Model		GMV-ND22C/ A-T	GMV-ND28C/ A-T	GMV-ND36C/ A-T	GMV-ND45C/ A-T	GMV-ND50C/ A-T	
Cooling capacity	kW	2.2	2.8	3.6	4.5	5.0	
Heating capacity	kW	2.5	3.2	4.0	5.0	5.5	
Air volume	m ³ /h	450	500	600	630	650	
Cooling power input	W	15	15	20	40	40	
Cooling current input	A	0.17	0.17	0.25	0.25	0.4	
Heating power input	W	15	15	20	40	40	
Heating current input	A	0.17	0.17	0.25	0.25	0.4	
*Minimum line current	A	0.16	0.16	0.16	0.16	0.16	
*Maximum fuse current	A	6	6	6	6	6	
Sound pressure level	dB(A)	36	38	40	43	46	
Power supply		220-240V 1 phase ~50Hz/208-230V 1 phase ~60Hz					
Piping interface	Liquid pipe	mm	6.35	6.35	6.35	6.35	6.35
	Gas pipe	mm	9.52	9.52	12.7	12.7	12.7
Drain pipe	External diameter × thickness	mm	Φ17.2×1.0	Φ17.2×1.0	Φ17.2×1.0	Φ17.2×1.0	Φ17.2×1.0
Dimensions	W×D×H	mm	700×215×600	700×215×600	700×215×600	700×215×600	700×215×600
Net weight		kg	16	16	16	16	16

Notes:

- ① Rated Cooling capacity test conditions: indoor 27°C DB/19°C WB, outdoor 35°C DB; connection pipe length: 5 m, without height drop between units.
- ② Rated heating capacity test conditions: indoor 20°C DB, outdoor 7°C DB/6 °C WB; connection pipe length: 5 m, without height drop between units.

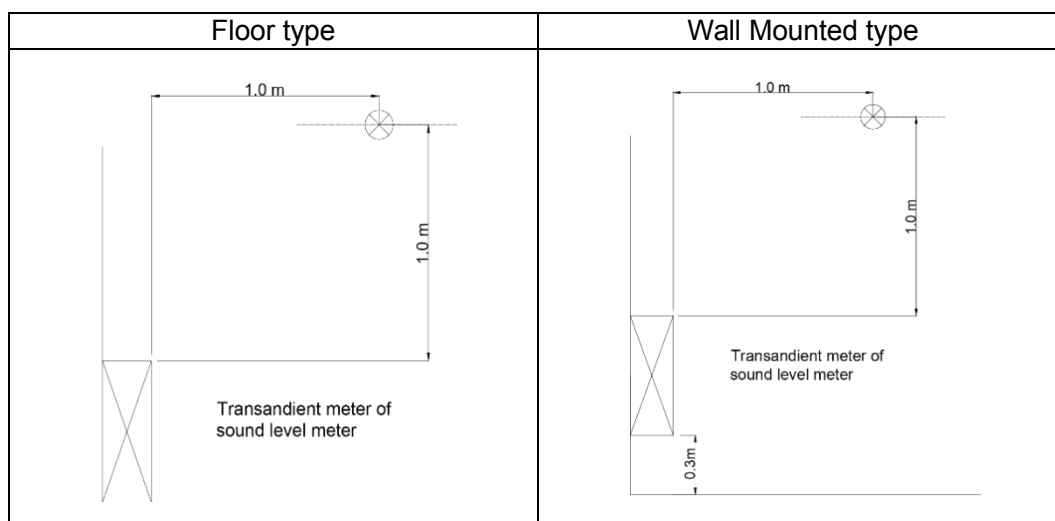

3.14 Wall Mounted Type Indoor Unit

Model			GMV-N22G/A 3A-K	GMV-N28G/A 3A-K	GMV-N36G/A 3A-K	GMV-N45G/A 3A-K	GMV-N50G/A 3A-K
Cooling capacity	kW		2.2	2.8	3.6	4.5	5.0
Heating capacity	kW		2.5	3.2	4.0	5.0	5.8
Air volume	m ³ /h		500	500	630	630	630
Cooling power input	W		50	50	60	60	60
Cooling current input	A		0.2	0.2	0.31	0.31	0.31
Heating power input	W		50	50	60	60	60
Heating current input	A		0.2	0.2	0.31	0.31	0.31
*Minimum line current	A		0.25	0.25	0.38	0.38	0.38
*Maximum fuse current	A		6	6	6	6	6
Sound pressure level	dB(A)		38	38	44	44	44
Power supply			220-240V 1 phase ~50Hz				
Piping interface	Liquid pipe	mm	Φ6.35	Φ6.35	Φ6.35	Φ6.35	Φ6.35
	Gas pipe	mm	Φ9.52	Φ9.52	Φ12.7	Φ12.7	Φ12.7
Drain pipe	External diameter × thickness	mm	Φ20×1.5	Φ20×1.5	Φ20×1.5	Φ20×1.5	Φ20×1.5
Dimensions	W×D×H	mm	843×180×275	843×180×275	940×200×298	940×200×298	940×200×298
Net weight		kg	10	10	12.5	12.5	12.5

Model			GMV-N56G/A3A-K	GMV-N63G/A3A-K	GMV-N71G/A3A-K
Cooling capacity	kW		5.6	6.3	7.1
Heating capacity	kW		6.3	7.0	7.5
Air volume	m ³ /h		750	750	750
Cooling power input	W		70	70	70
Cooling current input	A		0.31	0.31	0.31
Heating power input	W		70	70	70
Heating current input	A		0.31	0.31	0.31
*Minimum line current	A		0.5	0.5	0.5
*Maximum fuse current	A		6	6	6
Sound pressure level	dB(A)		44	44	44
Power supply			220-240V 1 phase ~50Hz		
Piping interface	Liquid pipe	mm	Φ9.52	Φ9.52	Φ9.52
	Gas pipe	mm	Φ15.9	Φ15.9	Φ15.9
Drain pipe	External diameter × thickness	mm	Φ20×1.5	Φ20×1.5	Φ20×1.5
Dimensions	W×D×H	mm	1008×221×319	1008×221×319	1008×221×319
Net weight		kg	15	15	15

Model			GMV-N22G/B 3A-K	GMV-N28G/B 3A-K	GMV-N36G/B 3A-K	GMV-N45G/B 3A-K	GMV-N50G/B 3A-K
Cooling capacity	kW		2.2	2.8	3.6	4.5	5.0
Heating capacity	kW		2.5	3.2	4.0	5.0	5.8
Air volume	m ³ /h		500	500	630	630	630
Cooling power input	W		50	50	60	60	60
Cooling current input	A		0.2	0.2	0.31	0.31	0.31
Heating power input	W		50	50	60	60	60
Heating current input	A		0.2	0.2	0.31	0.31	0.31
*Minimum line current	A		0.25	0.25	0.38	0.38	0.38
*Maximum fuse current	A		6	6	6	6	6
Sound pressure level	dB(A)		38	38	44	44	44
Power supply		220-240V 1 phase ~50Hz					
Piping interface	Liquid pipe	mm	Φ6.35	Φ6.35	Φ6.35	Φ6.35	Φ6.35
	Gas pipe	mm	Φ9.52	Φ9.52	Φ12.7	Φ12.7	Φ12.7
Drain pipe	External diameter × thickness	mm	Φ20×1.5	Φ20×1.5	Φ20×1.5	Φ20×1.5	Φ20×1.5
Dimensions	W×D×H	mm	843x180x275	843x180x275	940x200x298	940x200x298	940x200x298
Net weight		kg	10	10	12.5	12.5	12.5

Model			GMV-N56G/B3A-K	GMV-N63G/B3A-K	GMV-N71G/B3A-K
Cooling capacity	kW		5.6	6.3	7.1
Heating capacity	kW		6.3	7.0	7.5
Air volume	m ³ /h		750	750	750
Cooling power input	W		70	70	70
Cooling current input	A		0.31	0.31	0.31
Heating power input	W		70	70	70
Heating current input	A		0.31	0.31	0.31
*Minimum line current	A		0.5	0.5	0.5
*Maximum fuse current	A		6	6	6
Sound pressure level	dB(A)		44	44	44
Power supply		220-240V 1 phase ~50Hz			
Piping interface	Liquid pipe	mm	Φ9.52	Φ9.52	Φ9.52
	Gas pipe	mm	Φ15.9	Φ15.9	Φ15.9
Drain pipe	External diameter × thickness	mm	Φ20×1.5	Φ20×1.5	Φ20×1.5
Dimensions	W×D×H	mm	1008×221×319	1008×221×319	1008×221×319
Net weight		kg	15	15	15

Model			GMV-N22G/A 2A-K	GMV-N28G/A 2A-K	GMV-N36G/A 2A-K	GMV-N45G/A 2A-K	GMV-N50G/A 2A-K
Cooling capacity	kW		2.2	2.8	3.6	4.5	5.0
Heating capacity	kW		2.5	3.2	4.0	5.0	5.8
Air volume	m ³ /h		500	500	630	630	630
Cooling power input	W		50	50	60	60	60
Cooling current input	A		0.2	0.2	0.31	0.31	0.31
Heating power input	W		50	50	60	60	60
Heating current input	A		0.2	0.2	0.31	0.31	0.31
*Minimum line current	A		0.25	0.25	0.38	0.38	0.38
*Maximum fuse current	A		6	6	6	6	6
Sound pressure level	dB(A)		38	38	44	44	44
Power supply			220-240V 1 phase ~50Hz				
Piping interface	Liquid pipe	mm	Φ6.35	Φ6.35	Φ6.35	Φ6.35	Φ6.35
	Gas pipe	mm	Φ9.52	Φ9.52	Φ12.7	Φ12.7	Φ12.7
Drain pipe	External diameter × thickness	mm	Φ20×1.5	Φ20×1.5	Φ20×1.5	Φ20×1.5	Φ20×1.5
Dimensions	W×D×H	mm	843×180×275	843×180×275	940×200×298	940×200×298	940×200×298
Net weight		kg	10	10	12.5	12.5	12.5

Model			GMV-N56G/A2A-K	GMV-N63G/A2A-K	GMV-N71G/A2A-K
Cooling capacity	kW		5.6	6.3	7.1
Heating capacity	kW		6.3	7.0	7.5
Air volume	m ³ /h		750	750	750
Cooling power input	W		70	70	70
Cooling current input	A		0.31	0.31	0.31
Heating power input	W		70	70	70
Heating current input	A		0.31	0.31	0.31
*Minimum line current	A		0.5	0.5	0.5
*Maximum fuse current	A		6	6	6
Sound pressure level	dB(A)		44	44	44
Power supply			220-240V 1 phase ~50Hz		
Piping interface	Liquid pipe	mm	Φ9.52	Φ9.52	Φ9.52
	Gas pipe	mm	Φ15.9	Φ15.9	Φ15.9
Drain pipe	External diameter × thickness	mm	Φ20×1.5	Φ20×1.5	Φ20×1.5
Dimensions	W×D×H	mm	1008×221×319	1008×221×319	1008×221×319
Net weight		kg	15	15	15

Model			GMV-N22G/ A4A-K	GMV-N28G/ A4A-K	GMV-N36G/ A4A-K	GMV-N45G/ A4A-K	GMV-N50G/ A4A-K
Cooling capacity	kW		2.2	2.8	3.6	4.5	5.0
Heating capacity	kW		2.5	3.2	4.0	5.0	5.8
Air volume	m ³ /h		500	500	630	630	630
Cooling power input	W		50	50	60	60	60
Cooling current input	A		0.2	0.2	0.31	0.31	0.31
Heating power input	W		50	50	60	60	60
Heating current input	A		0.2	0.2	0.31	0.31	0.31
*Minimum line current	A		0.25	0.25	0.38	0.38	0.38
*Maximum fuse current	A		6	6	6	6	6
Sound pressure level	dB(A)		38	38	44	44	44
Power supply			220-240V 1 phase ~50Hz				
Piping interface	Liquid pipe	mm	Φ6.35	Φ6.35	Φ6.35	Φ6.35	Φ6.35
	Gas pipe	mm	Φ9.52	Φ9.52	Φ12.7	Φ12.7	Φ12.7
Drain pipe	External diameter ×thickness	mm	Φ20×1.5	Φ20×1.5	Φ20×1.5	Φ20×1.5	Φ20×1.5
Dimensions	W×D×H	mm	843×180×275	843×180×275	940×200×298	940×200×298	940×200×298
Net weight		kg	10	10	12.5	12.5	12.5

Model			GMV-N56G/A4A-K	GMV-N63G/A4A-K	GMV-N71G/A4A-K
Cooling capacity	kW		5.6	6.3	7.1
Heating capacity	kW		6.3	7.0	7.5
Air volume	m ³ /h		750	750	750
Cooling power input	W		70	70	70
Cooling current input	A		0.31	0.31	0.31
Heating power input	W		70	70	70
Heating current input	A		0.31	0.31	0.31
*Minimum line current	A		0.5	0.5	0.5
*Maximum fuse current	A		6	6	6
Sound pressure level	dB(A)		44	44	44
Power supply			220-240V 1 phase ~50Hz		
Piping interface	Liquid pipe	mm	Φ9.52	Φ9.52	Φ9.52
	Gas pipe	mm	Φ15.9	Φ15.9	Φ15.9
Drain pipe	External diameter ×thickness	mm	Φ20×1.5	Φ20×1.5	Φ20×1.5
Dimensions	W×D×H	mm	1008×221×319	1008×221×319	1008×221×319
Net weight		kg	15	15	15

Model			GMV-N22G/ A8A-K	GMV-N28G/ A8A-K	GMV-N36G/ A8A-K	GMV-N45G/ A8A-K	GMV-N50G/ A8A-K
Cooling capacity	kW		2.2	2.8	3.6	4.5	5.0
Heating capacity	kW		2.5	3.2	4.0	5.0	5.8
Air volume	m ³ /h		500	500	630	630	630
Cooling power input	W		50	50	60	60	60
Cooling current input	A		0.2	0.2	0.31	0.31	0.31
Heating power input	W		50	50	60	60	60
Heating current input	A		0.2	0.2	0.31	0.31	0.31
*Minimum line current	A		0.25	0.25	0.38	0.38	0.38
*Maximum fuse current	A		6	6	6	6	6
Sound pressure level	dB(A)		38	38	44	44	44
Power supply			220-240V 1 phase ~50Hz				
Piping interface	Liquid pipe	mm	Φ6.35	Φ6.35	Φ6.35	Φ6.35	Φ6.35
	Gas pipe	mm	Φ9.52	Φ9.52	Φ12.7	Φ12.7	Φ12.7
Drain pipe	External diameter× thickness	mm	Φ20×1.5	Φ20×1.5	Φ20×1.5	Φ20×1.5	Φ20×1.5
Dimensions	W×D×H	mm	843×180×27 5	843×180×27 5	940×200×29 8	940×200×29 8	940×200×29 8
Net weight		kg	10	10	12.5	12.5	12.5

Model			GMV-N56G/A8A-K	GMV-N63G/A8A-K	GMV-N71G/A8A-K
Cooling capacity	kW		5.6	6.3	7.1
Heating capacity	kW		6.3	7.0	7.5
Air volume	m ³ /h		750	750	750
Cooling power input	W		70	70	70
Cooling current input	A		0.31	0.31	0.31
Heating power input	W		70	70	70
Heating current input	A		0.31	0.31	0.31
*Minimum line current	A		0.5	0.5	0.5
*Maximum fuse current	A		6	6	6
Sound pressure level	dB(A)		44	44	44
Power supply			220-240V 1 phase ~50Hz		
Piping interface	Liquid pipe	mm	Φ9.52	Φ9.52	Φ9.52
	Gas pipe	mm	Φ15.9	Φ15.9	Φ15.9
Drain pipe	External diameter× thickness	mm	Φ20×1.5	Φ20×1.5	Φ20×1.5
Dimensions	W×D×H	mm	1008×221×319	1008×221×319	1008×221×319
Net weight		kg	15	15	15

Model		GMV-N22G/C9A-K	GMV-N28G/C9A-K	GMV-N36G/C9A-K	GMV-N45G/C9A-K	GMV-N50G/C9A-K
Cooling capacity	kW	2.2	2.8	3.6	4.5	5.0
Heating capacity	kW	2.5	3.2	4.0	5.0	5.8
Air volume	m ³ /h	500	500	630	630	630
Cooling power input	W	50	50	60	60	60
Cooling current input	A	0.2	0.2	0.31	0.31	0.31
Heating power input	W	50	50	60	60	60
Heating current input	A	0.2	0.2	0.31	0.31	0.31
*Minimum line current	A	0.25	0.25	0.38	0.38	0.38
*Maximum fuse current	A	6	6	6	6	6
Sound pressure level	dB(A)	38	38	44	44	44
Power supply		220-240V 1 phase ~50Hz				
Piping interface	Liquid pipe	mm	Φ6.35	Φ6.35	Φ6.35	Φ6.35
	Gas pipe	mm	Φ9.52	Φ9.52	Φ12.7	Φ12.7
Drain pipe	External diameter× thickness	mm	Φ20×1.5	Φ20×1.5	Φ20×1.5	Φ20×1.5
Dimensions	W×D×H	mm	843×180×275	843×180×275	940×200×298	940×200×298
Net weight		kg	10	10	12.5	12.5

Model		GMV-N56G/C9A-K	GMV-N63G/C9A-K	GMV-N71G/C9A-K
Cooling capacity	kW	5.6	6.3	7.1
Heating capacity	kW	6.3	7.0	7.5
Air volume	m ³ /h	750	750	750
Cooling power input	W	70	70	70
Cooling current input	A	0.31	0.31	0.31
Heating power input	W	70	70	70
Heating current input	A	0.31	0.31	0.31
*Minimum line current	A	0.5	0.5	0.5
*Maximum fuse current	A	6	6	6
Sound pressure level	dB(A)	44	44	44
Power supply		220-240V 1 phase ~50Hz		
Piping interface	Liquid pipe	mm	Φ9.52	Φ9.52
	Gas pipe	mm	Φ15.9	Φ15.9
Drain pipe	External diameter× thickness	mm	Φ20×1.5	Φ20×1.5
Dimensions	W×D×H	mm	1008×221×319	1008×221×319
Net weight		kg	15	15

Model		GMV-N22G/ E3A-K	GMV-N28G/ E3A-K	GMV-N36G/ E3A-K	GMV-N45G/ E3A-K	GMV-N50G/ E3A-K
Cooling capacity	kW	2.2	2.8	3.6	4.5	5.0
Heating capacity	kW	2.5	3.2	4.0	5.0	5.8
Air volume	m ³ /h	500	500	630	630	630
Cooling power input	W	50	50	60	60	60
Cooling current input	A	0.2	0.2	0.31	0.31	0.31
Heating power input	W	50	50	60	60	60
Heating current input	A	0.2	0.2	0.31	0.31	0.31
*Minimum line current	A	0.25	0.25	0.38	0.38	0.38
*Maximum fuse current	A	6	6	6	6	6
Sound pressure level	dB(A)	38	38	44	44	44
Power supply		220-240V 1 phase ~50Hz				
Piping interface	Liquid pipe	mm	Φ6.35	Φ6.35	Φ6.35	Φ6.35
	Gas pipe	mm	Φ9.52	Φ9.52	Φ12.7	Φ12.7
Drain pipe	External diameter ×thickness	mm	Φ20×1.5	Φ20×1.5	Φ20×1.5	Φ20×1.5
Dimensions	W×D×H	mm	843×180×275	843×180×275	940×200×298	940×200×298
Net weight	kg	10	10	12.5	12.5	12.5

Model		GMV-N56G/ E3A-K	GMV-N63G/ E3A-K	GMV-N71G/ E3A-K
Cooling capacity	kW	5.6	6.3	7.1
Heating capacity	kW	6.3	7.0	7.5
Air volume	m ³ /h	750	750	750
Cooling power input	W	70	70	70
Cooling current input	A	0.31	0.31	0.31
Heating power input	W	70	70	70
Heating current input	A	0.31	0.31	0.31
*Minimum line current	A	0.5	0.5	0.5
*Maximum fuse current	A	6	6	6
Sound pressure level	dB(A)	44	44	44
Power supply		220-240V 1 phase ~50Hz		
Piping interface	Liquid pipe	mm	Φ9.52	Φ9.52
	Gas pipe	mm	Φ15.9	Φ15.9
Drain pipe	External diameter ×thickness	mm	Φ20×1.5	Φ20×1.5
Dimensions	W×D×H	mm	1008×221×319	1008×221×319
Net weight	kg	15	15	15

Model			GMV-N22G/A3A -D	GMV-N28G/A3A -D	GMV-N36G/A3A -D	GMV-N45G/A3A -D
Cooling capacity	kW		2.2	2.8	3.6	4.5
Heating capacity	kW		2.5	3.2	4.0	5.0
Air volume	m ³ /h		500	500	630	630
Cooling power input	W		50	50	60	60
Cooling current input	A		0.2	0.2	0.21	0.21
Heating power input	W		50	50	60	60
Heating current input	A		0.2	0.2	0.21	0.21
*Minimum line current	A		0.25	0.25	0.38	0.38
*Maximum fuse current	A		6	6	6	6
Sound pressure level	dB(A)		38	38	44	44
Power supply			208-230V~60Hz			
Piping interface	Liquid pipe	mm	Φ6.35	Φ6.35	Φ6.35	Φ6.35
	Gas pipe	mm	Φ9.52	Φ9.52	Φ12.7	Φ12.7
Drain pipe	External diameter ×thickness	mm	Φ20×1.5	Φ20×1.5	Φ20×1.5	Φ20×1.5
Dimensions	W×D×H	mm	843×180×275	843×180×275	940×200×298	940×200×298
Net weight	Main body	kg	10.0	10.0	12.5	12.5

Model			GMV-N50G/A3A -D	GMV-N56G/A3A -D	GMV-N63G/A3A -D	GMV-N71G/A3A -D
Cooling capacity	kW		5.0	5.6	6.3	7.1
Heating capacity	kW		5.8	6.3	7.0	7.5
Air volume	m ³ /h		630	750	750	750
Cooling power input	W		60	70	70	70
Cooling current input	A		0.21	0.31	0.31	0.31
Heating power input	W		60	70	70	70
Heating current input	A		0.21	0.31	0.31	0.31
*Minimum line current	A		0.38	0.5	0.5	0.5
*Maximum fuse current	A		6	6	6	6
Sound pressure level	dB(A)		44	44	44	44
Power supply			208-230V~60Hz			
Piping interface	Liquid pipe	mm	Φ6.35	Φ9.52	Φ9.52	Φ9.52
	Gas pipe	mm	Φ12.7	Φ15.9	Φ15.9	Φ15.9
Drain pipe	External diameter ×thickness	mm	Φ20×1.5	Φ20×1.5	Φ20×1.5	Φ20×1.5
Dimensions	W×D×H	mm	940×200×298	1008×221×319	1008×221×319	1008×221×319
Net weight	Main body	kg	12.5	15.0	15.0	15.0

Model			GMV-N22G/A2A -D	GMV-N28G/A2A -D	GMV-N36G/A2A -D	GMV-N45G/A2A -D
Cooling capacity	kW		2.2	2.8	3.6	4.5
Heating capacity	kW		2.5	3.2	4.0	5.0
Air volume	m ³ /h		500	500	630	630
Cooling power input	W		50	50	60	60
Cooling current input	A		0.2	0.2	0.21	0.21
Heating power input	W		50	50	60	60
Heating current input	A		0.2	0.2	0.21	0.21
*Minimum line current	A		0.25	0.25	0.38	0.38
*Maximum fuse current	A		6	6	6	6
Sound pressure level	dB(A)		38	38	44	44
Power supply			208-230V~60Hz			
Piping interface	Liquid pie	mm	Φ6.35	Φ6.35	Φ6.35	Φ6.35
	Gas pipe	mm	Φ9.52	Φ9.52	Φ12.7	Φ12.7
Drain pipe	Outer diameter×Wall thickness	mm	Φ20×1.5	Φ20×1.5	Φ20×1.5	Φ20×1.5
Dimensions	W×D×H	mm	843×180×275	843×180×275	940×200×298	940×200×298
Net weight	Main body	kg	10.0	10.0	12.5	12.5

Model			GMV-N50G/A2A- D	GMV-N56G/A2A- D	GMV-N63G/A2A- D	GMV-N71G/A2A- D
Cooling capacity	kW		5.0	5.6	6.3	7.1
Heating capacity	kW		5.8	6.3	7.0	7.5
Air volume	m ³ /h		630	750	750	750
Cooling power input	W		60	70	70	70
Cooling current input	A		0.21	0.31	0.31	0.31
Heating power input	W		60	70	70	70
Heating current input	A		0.21	0.31	0.31	0.31
*Minimum line current	A		0.38	0.5	0.5	0.5
*Maximum fuse current	A		6	6	6	6
Sound pressure level	dB(A)		44	44	44	44
Power supply			208-230V~60Hz			
Piping interface	Liquid pie	mm	Φ6.35	Φ9.52	Φ9.52	Φ9.52
	Gas pipe	mm	Φ12.7	Φ15.9	Φ15.9	Φ15.9
Drain pipe	Outer diameter×Wall thickness	mm	Φ20×1.5	Φ20×1.5	Φ20×1.5	Φ20×1.5
Dimensions	W×D×H	mm	940×200×298	1008×221×319	1008×221×319	1008×221×319
Net weight	Main body	kg	12.5	15.0	15.0	15.0

Model			GMV-N22G/A4A-D	GMV-N28G/A4A-D	GMV-N36G/A4A-D	GMV-N45G/A4A-D
Cooling capacity	kW		2.2	2.8	3.6	4.5
Heating capacity	kW		2.5	3.2	4.0	5.0
Air volume	m ³ /h		500	500	630	630
Cooling power input	W		50	50	60	60
Cooling current input	A		0.2	0.2	0.21	0.21
Heating power input	W		50	50	60	60
Heating current input	A		0.2	0.2	0.21	0.21
*Minimum line current	A		0.25	0.25	0.38	0.38
*Maximum fuse current	A		6	6	6	6
Sound pressure level	dB(A)		38	38	44	44
Power supply			208-230V~60Hz			
Piping interface	Liquid pipe	mm	Φ6.35	Φ6.35	Φ6.35	Φ6.35
	Gas pipe	mm	Φ9.52	Φ9.52	Φ12.7	Φ12.7
Drain pipe	Outer diameter×Wall thickness	mm	Φ20×1.5	Φ20×1.5	Φ20×1.5	Φ20×1.5
Dimensions	W×D×H	mm	843×180×275	843×180×275	940×200×298	940×200×298
Net weight	Main body	kg	10.0	10.0	12.5	12.5

Model			GMV-N50G/A4A-D	GMV-N56G/A4A-D	GMV-N63G/A4A-D	GMV-N71G/A4A-D
Cooling capacity	kW		5.0	5.6	6.3	7.1
Heating capacity	kW		5.8	6.3	7.0	7.5
Air volume	m ³ /h		630	750	750	750
Cooling power input	W		60	70	70	70
Cooling current input	A		0.21	0.31	0.31	0.31
Heating power input	W		60	70	70	70
Heating current input	A		0.21	0.31	0.31	0.31
*Minimum line current	A		0.38	0.5	0.5	0.5
*Maximum fuse current	A		6	6	6	6
Sound pressure level	dB(A)		44	44	44	44
Power supply			208-230V~60Hz			
Piping interface	Liquid pipe	mm	Φ6.35	Φ9.52	Φ9.52	Φ9.52
	Gas pipe	mm	Φ12.7	Φ15.9	Φ15.9	Φ15.9
Drain pipe	Outer diameter×Wall thickness	mm	Φ20×1.5	Φ20×1.5	Φ20×1.5	Φ20×1.5
Dimensions	W×D×H	mm	940×200×298	1008×221×319	1008×221×319	1008×221×319
Net weight	Main body	kg	12.5	15.0	15.0	15.0

Model		GMV-N22G/A8A-D	GMV-N28G/A8A-D	GMV-N36G/A8A-D	GMV-N45G/A8A-D
Cooling capacity	kW	2.2	2.8	3.6	4.5
Heating capacity	kW	2.5	3.2	4.0	5.0
Air volume	m ³ /h	500	500	630	630
Cooling power input	W	50	50	60	60
Cooling current input	A	0.2	0.2	0.21	0.21
Heating power input	W	50	50	60	60
Heating current input	A	0.2	0.2	0.21	0.21
*Minimum line current	A	0.25	0.25	0.38	0.38
*Maximum fuse current	A	6	6	6	6
Sound pressure level	dB(A)	38	38	44	44
Power supply		208-230V~60Hz			
Piping interface	Liquid pie	mm	Φ6.35	Φ6.35	Φ6.35
	Gas pipe	mm	Φ9.52	Φ9.52	Φ12.7
Drain pipe	Outer diameter×Wall thickness	mm	Φ20×1.5	Φ20×1.5	Φ20×1.5
Dimensions	W×D×H	mm	843×180×275	843×180×275	940×200×298
Net weight	Main body	kg	10.0	10.0	12.5

Model		GMV-N50G/A8A-D	GMV-N56G/A8A-D	GMV-N63G/A8A-D	GMV-N71G/A8A-D
Cooling capacity	kW	5.0	5.6	6.3	7.1
Heating capacity	kW	5.8	6.3	7.0	7.5
Air volume	m ³ /h	630	750	750	750
Cooling power input	W	60	70	70	70
Cooling current input	A	0.21	0.31	0.31	0.31
Heating power input	W	60	70	70	70
Heating current input	A	0.21	0.31	0.31	0.31
*Minimum line current	A	0.38	0.5	0.5	0.5
*Maximum fuse current	A	6	6	6	6
Sound pressure level	dB(A)	44	44	44	44
Power supply		208-230V~60Hz			
Piping interface	Liquid pie	mm	Φ6.35	Φ9.52	Φ9.52
	Gas pipe	mm	Φ12.7	Φ15.9	Φ15.9
Drain pipe	Outer diameter×Wall thickness	mm	Φ20×1.5	Φ20×1.5	Φ20×1.5
Dimensions	W×D×H	mm	940×200×298	1008×221×319	1008×221×319
Net weight	Main body	kg	12.5	15.0	15.0

Model		GMV-N22G/C9A-D	GMV-N28G/C9A-D	GMV-N36G/C9A-D	GMV-N45G/C9A-D
Cooling capacity	kW	2.2	2.8	3.6	4.5
Heating capacity	kW	2.5	3.2	4.0	5.0
Air volume	m ³ /h	500	500	630	630
Cooling power input	W	50	50	60	60
Cooling current input	A	0.2	0.2	0.21	0.21
Heating power input	W	50	50	60	60
Heating current input	A	0.2	0.2	0.21	0.21
*Minimum line current	A	0.25	0.25	0.38	0.38
*Maximum fuse current	A	6	6	6	6
Sound pressure level	dB(A)	38	38	44	44
Power supply		208-230V~60Hz			
Piping interface	Liquid pipe	mm	Φ6.35	Φ6.35	Φ6.35
	Gas pipe	mm	Φ9.52	Φ9.52	Φ12.7
Drain pipe	Outer diameter× Wall thickness	mm	Φ20×1.5	Φ20×1.5	Φ20×1.5
Dimensions	W×D×H	mm	843×180×275	843×180×275	940×200×298
Net weight	Main body	kg	10.0	10.0	12.5

Model		GMV-N50G/C9A-D	GMV-N56G/C9A-D	GMV-N63G/C9A-D	GMV-N71G/C9A-D
Cooling capacity	kW	5.0	5.6	6.3	7.1
Heating capacity	kW	5.8	6.3	7.0	7.5
Air volume	m ³ /h	630	750	750	750
Cooling power input	W	60	70	70	70
Cooling current input	A	0.21	0.31	0.31	0.31
Heating power input	W	60	70	70	70
Heating current input	A	0.21	0.31	0.31	0.31
*Minimum line current	A	0.38	0.5	0.5	0.5
*Maximum fuse current	A	6	6	6	6
Sound pressure level	dB(A)	44	44	44	44
Power supply		208-230V~60Hz			
Piping interface	Liquid pipe	mm	Φ6.35	Φ9.52	Φ9.52
	Gas pipe	mm	Φ12.7	Φ15.9	Φ15.9
Drain pipe	Outer diameter× Wall thickness	mm	Φ20×1.5	Φ20×1.5	Φ20×1.5
Dimensions	W×D×H	mm	940×200×298	1008×221×319	1008×221×319
Net weight	Main body	kg	12.5	15.0	15.0

Model		GMV-N22G/E3A-D	GMV-N28G/E3A-D	GMV-N36G/E3A-D	GMV-N45G/E3A-D
Cooling capacity	kW	2.2	2.8	3.6	4.5
Heating capacity	kW	2.5	3.2	4.0	5.0
Air volume	m ³ /h	500	500	630	630
Cooling power input	W	50	50	60	60
Cooling current input	A	0.2	0.2	0.21	0.21
Heating power input	W	50	50	60	60
Heating current input	A	0.2	0.2	0.21	0.21
*Minimum line current	A	0.25	0.25	0.38	0.38
*Maximum fuse current	A	6	6	6	6
Sound pressure level	dB(A)	38	38	44	44
Power supply		208-230V~60Hz			
Piping interface	Liquid pie	mm	Φ6.35	Φ6.35	Φ6.35
	Gas pipe	mm	Φ9.52	Φ9.52	Φ12.7
Drain pipe	Outer diameter×Wall thickness	mm	Φ20×1.5	Φ20×1.5	Φ20×1.5
Dimensions	W×D×H	mm	843×180×275	843×180×275	940×200×298
Net weight	Main body	kg	10.0	10.0	12.5

Model		GMV-N50G/E3A-D	GMV-N56G/E3A-D	GMV-N63G/E3A-D	GMV-N71G/E3A-D
Cooling capacity	kW	5.0	5.6	6.3	7.1
Heating capacity	kW	5.8	6.3	7.0	7.5
Air volume	m ³ /h	630	750	750	750
Cooling power input	W	60	70	70	70
Cooling current input	A	0.21	0.31	0.31	0.31
Heating power input	W	60	70	70	70
Heating current input	A	0.21	0.31	0.31	0.31
*Minimum line current	A	0.38	0.5	0.5	0.5
*Maximum fuse current	A	6	6	6	6
Sound pressure level	dB(A)	44	44	44	44
Power supply		208-230V~60Hz			
Piping interface	Liquid pie	mm	Φ6.35	Φ9.52	Φ9.52
	Gas pipe	mm	Φ12.7	Φ15.9	Φ15.9
Drain pipe	Outer diameter×Wall thickness	mm	Φ20×1.5	Φ20×1.5	Φ20×1.5
Dimensions	W×D×H	mm	940×200×298	1008×221×319	1008×221×319
Net weight	Main body	kg	12.5	15.0	15.0

Model			GMV-N22G/B3A-D	GMV-N28G/B3A-D	GMV-N36G/B3A-D	GMV-N45G/B3A-D
Cooling capacity	kW		2.2	2.8	3.6	4.5
Heating capacity	kW		2.5	3.2	4.0	5.0
Air volume	m ³ /h		500	500	630	630
Cooling power input	W		50	50	60	60
Cooling current input	A		0.2	0.2	0.21	0.21
Heating power input	W		50	50	60	60
Heating current input	A		0.2	0.2	0.21	0.21
*Minimum line current	A		0.25	0.25	0.38	0.38
*Maximum fuse current	A		6	6	6	6
Sound pressure level	dB(A)		38	38	44	44
Power supply			208-230V~60Hz			
Piping interface	Liquid pipe	mm	Φ6.35	Φ6.35	Φ6.35	Φ6.35
	Gas pipe	mm	Φ9.52	Φ9.52	Φ12.7	Φ12.7
Drain pipe	External diameter× thickness	mm	Φ20×1.5	Φ20×1.5	Φ20×1.5	Φ20×1.5
Dimensions	W×D×H	mm	843×180×275	843×180×275	940×200×298	940×200×298
Net weight	Main body	kg	10.0	10.0	12.5	12.5

Model			GMV-N50G/B3A-D	GMV-N56G/B3A-D	GMV-N63G/B3A-D	GMV-N71G/B3A-D
Cooling capacity	kW		5.0	5.6	6.3	7.1
Heating capacity	kW		5.8	6.3	7.0	7.5
Air volume	m ³ /h		630	750	750	750
Cooling power input	W		60	70	70	70
Cooling current input	A		0.21	0.31	0.31	0.31
Heating power input	W		60	70	70	70
Heating current input	A		0.21	0.31	0.31	0.31
*Minimum line current	A		0.38	0.5	0.5	0.5
*Maximum fuse current	A		6	6	6	6
Sound pressure level	dB(A)		44	44	44	44
Power supply			208-230V~60Hz			
Piping interface	Liquid pipe	mm	Φ6.35	Φ9.52	Φ9.52	Φ9.52
	Gas pipe	mm	Φ12.7	Φ15.9	Φ15.9	Φ15.9
Drain pipe	External diameter× thickness	mm	Φ20×1.5	Φ20×1.5	Φ20×1.5	Φ20×1.5
Dimensions	W×D×H	mm	940×200×298	1008×221×319	1008×221×319	1008×221×319
Net weight	Main body	kg	12.5	15.0	15.0	15.0

Model			GMV-ND22 G/A3A-T	GMV-ND28 G/A3A-T	GMV-ND36 G/A3A-T	GMV-ND45 G/A3A-T	GMV-ND50 G/A3A-T	GMV-ND56 G/A3A-T
Cooling capacity	kW		2.2	2.8	3.6	4.5	5.0	5.6
Heating capacity	kW		2.5	3.2	4.0	5.0	5.8	6.3
Air volume	m ³ /h		500	500	630	630	630	750
Cooling power input	W		20	20	30	30	30	40
Cooling current input	A		0.1	0.1	0.16	0.16	0.16	0.17
Heating power input	W		20	20	30	30	30	40
Heating current input	A		0.1	0.1	0.16	0.16	0.16	0.17
*Minimum line current	A		0.1	0.1	0.15	0.15	0.15	0.2
*Maximum fuse current	A		6	6	6	6	6	6
Sound pressure level	dB(A)		38	38	44	44	44	44
Power supply			220-240V 1 phase ~50Hz/208-230V 1 phase ~60Hz					
Piping interface	Liquid pipe	mm	Φ6.35	Φ6.35	Φ6.35	Φ6.35	Φ6.35	Φ9.52
	Gas pipe	mm	Φ9.52	Φ9.52	Φ12.7	Φ12.7	Φ12.7	Φ15.9
Drain pipe	External diameter×thickness	mm	Φ20×1.5	Φ20×1.5	Φ20×1.5	Φ20×1.5	Φ20×1.5	Φ20×1.5
Dimensions	W×D×H	mm	843×180 ×275	843×180 ×275	940×200 ×298	940×200 ×298	940×200 ×298	1008×221 ×319
Net weight	Main body	kg	10.0	10.0	12.5	12.5	12.5	15.0

Model			GMV-ND63 G/A3A-T	GMV-ND71 G/A3A-T	GMV-ND80 G/A3A-T	GMV-ND90 G/A3A-T	GMV-ND100 G/A3A-T
Cooling capacity	kW		6.3	7.1	8.0	9.0	9.5
Heating capacity	kW		7.0	7.5	9.0	10.0	10.5
Air volume	m ³ /h		750	750	1550	1550	1650
Cooling power input	W		40	40	80	80	100
Cooling current input	A		0.17	0.17	0.41	0.41	0.41
Heating power input	W		40	40	80	80	100
Heating current input	A		0.17	0.17	0.41	0.41	0.41
*Minimum line current	A		0.2	0.2	0.2	0.2	0.2
*Maximum fuse current	A		6	6	6	6	6
Sound pressure level	dB(A)		44	44	49	49	52
Power supply			220-240V 1 phase ~50Hz/208-230V 1 phase ~60Hz				
Piping interface	Liquid pipe	mm	Φ9.52	Φ9.52	Φ9.52	Φ9.52	Φ9.52
	Gas pipe	mm	Φ15.9	Φ15.9	Φ15.9	Φ15.9	Φ15.9
Drain pipe	External diameter×thickness	mm	Φ20×1.5	Φ20×1.5	Φ20×1.5	Φ20×1.5	Φ20×1.5
Dimensions	W×D×H	mm	1008×221 ×319	1008×221 ×319	1350×258 ×326	1350×258 ×326	1350×258 ×326
Net weight	Main body	kg	15.0	15.0	18.5	18.5	18.5

Model			GMV-ND22 G/A8A-T	GMV-ND28 G/A8A-T	GMV-ND36 G/A8A-T	GMV-ND45 G/A8A-T	GMV-ND50 G/A8A-T	GMV-ND56 G/A8A-T
Cooling capacity	kW		2.2	2.8	3.6	4.5	5.0	5.6
Heating capacity	kW		2.5	3.2	4.0	5.0	5.8	6.3
Air volume	m ³ /h		500	500	630	630	630	750
Cooling power input	W		20	20	30	30	30	40
Cooling current input	A		0.1	0.1	0.16	0.16	0.16	0.17
Heating power input	W		20	20	30	30	30	40
Heating current input	A		0.1	0.1	0.16	0.16	0.16	0.17
*Minimum line current	A		0.1	0.1	0.15	0.15	0.15	0.2
*Maximum fuse current	A		6	6	6	6	6	6
Sound pressure level	dB(A)		38	38	44	44	44	44
Power supply			220-240V 1 phase ~50Hz/208-230V 1 phase ~60Hz					
Piping interface	Liquid pipe	mm	Φ6.35	Φ6.35	Φ6.35	Φ6.35	Φ6.35	Φ9.52
	Gas pipe	mm	Φ9.52	Φ9.52	Φ12.7	Φ12.7	Φ12.7	Φ15.9
Drain pipe	External diameter×thickness	mm	Φ20×1.5	Φ20×1.5	Φ20×1.5	Φ20×1.5	Φ20×1.5	Φ20×1.5
Dimensions	W×D×H	mm	843×180 ×275	843×180 ×275	940×200 ×298	940×200 ×298	940×200 ×298	1008×221 ×319
Net weight	Main body	kg	10.0	10.0	12.5	12.5	12.5	15.0

Model			GMV-ND63 G/A8A-T	GMV-ND71 G/A8A-T	GMV-ND80 G/A8A-T	GMV-ND90 G/A8A-T	GMV-ND100 G/A8A-T
Cooling capacity	kW		6.3	7.1	8.0	9.0	9.5
Heating capacity	kW		7.0	7.5	9.0	10.0	10.5
Air volume	m ³ /h		750	750	1550	1550	1650
Cooling power input	W		40	40	80	80	100
Cooling current input	A		0.17	0.17	0.41	0.41	0.41
Heating power input	W		40	40	80	80	100
Heating current input	A		0.17	0.17	0.41	0.41	0.41
*Minimum line current	A		0.2	0.2	0.2	0.2	0.2
*Maximum fuse current	A		6	6	6	6	6
Sound pressure level	dB(A)		44	44	49	49	52
Power supply			220-240V 1 phase ~50Hz/208-230V 1 phase ~60Hz				
Piping interface	Liquid pipe	mm	Φ9.52	Φ9.52	Φ9.52	Φ9.52	Φ9.52
	Gas pipe	mm	Φ15.9	Φ15.9	Φ15.9	Φ15.9	Φ15.9
Drain pipe	External diameter×thickness	mm	Φ20×1.5	Φ20×1.5	Φ20×1.5	Φ20×1.5	Φ20×1.5
Dimensions	W×D×H	mm	1008×221 ×319	1008×221 ×319	1350×258 ×326	1350×258 ×326	1350×258 ×326
Net weight	Main body	kg	15.0	15.0	18.5	18.5	18.5

Model			GMV-ND22G/B6 B-T	GMV-ND28G/ B6B-T	GMV-ND36G/ B6B-T	GMV-ND45G/ B6B-T
Cooling capacity	kW		2.2	2.8	3.6	4.5
Heating capacity	kW		2.5	3.2	4.0	5.0
Air volume	m ³ /h		500	500	630	850
Cooling power input	W		20	20	25	35
Cooling current input	A		0.1	0.1	0.12	0.17
Heating power input	W		20	20	25	35
Heating current input	A		0.1	0.1	0.12	0.17
*Minimum line current	A		0.1	0.1	0.15	0.15
*Maximum fuse current	A		6	6	6	6
Sound pressure level	dB(A)		35	35	38	43
Power supply			220-240V 1 phase ~50Hz/208-230V 1 phase ~60Hz			
Piping interface	Liquid pipe	mm	Φ6.35	Φ6.35	Φ6.35	Φ6.35
	Gas pipe	mm	Φ9.52	Φ9.52	Φ12.7	Φ12.7
Drain pipe	Outer diameter × Wall thickness	mm	Φ20×1.5	Φ20×1.5	Φ20×1.5	Φ20×1.5
Dimensions W×D×H		mm	845×289×209	845×289×209	845×289×209	970×300×224
Net weight	Main body	kg	10.5	10.5	10.5	12.5

Model			GMV- ND50G/B6B-T	GMV- ND56G/B6B-T	GMV- ND63G/B6B-T	GMV- ND71G/B6B-T
Cooling capacity	kW		5.0	5.6	6.3	7.1
Heating capacity	kW		5.6	6.3	7.1	7.5
Air volume	m ³ /h		850	1100	1100	1200
Cooling power input	W		35	50	50	65
Cooling current input	A		0.17	0.24	0.24	0.31
Heating power input	W		35	50	50	65
Heating current input	A		0.17	0.24	0.24	0.31
*Minimum line current	A		0.15	0.2	0.2	0.2
*Maximum fuse current	A		6	6	6	6
Sound pressure level	dB(A)		43	43	43	44
Power supply			220-240V 1 phase ~50Hz/208-230V 1 phase ~60Hz			
Piping interface	Liquid pipe	mm	Φ6.35	Φ9.52	Φ9.52	Φ9.52
	Gas pipe	mm	Φ12.7	Φ15.9	Φ15.9	Φ15.9
Drain pipe	Outer diameter × Wall thickness	mm	Φ20×1.5	Φ20×1.5	Φ20×1.5	Φ20×1.5
Dimensions W×D×H		mm	970×300×224	1078×325×246	1078×325×246	1078×325×246
Net weight	Main body	kg	12.5	16	16	16

Model			GMV-ND15G /B4B-T	GMV-ND18G /B4B-T	GMV-ND22G /B4B-T	GMV-ND28G /B4B-T	GMV-ND36G /B4B-T	GMV-ND45G/B 4B-T	
Cooling capacity	kW		1.5	1.8	2.2	2.8	3.6	4.5	
Heating capacity	kW		1.8	2.2	2.5	3.2	4.0	5.0	
Air volume	m ³ /h		500	500	500	500	630	850	
Cooling power input	W		20	20	20	20	25	35	
Cooling current input	A		0.1	0.1	0.1	0.1	0.12	0.17	
Heating power input	W		20	20	20	20	25	35	
Heating current input	A		0.1	0.1	0.1	0.1	0.12	0.17	
*Minimum line current	A		0.1	0.1	0.1	0.1	0.15	0.15	
*Maximum fuse current	A		6	6	6	6	6	6	
Sound pressure level	dB(A)		35	35	35	35	38	43	
Power supply			220-240V 1 phase ~50Hz/208-230V 1 phase ~60Hz						
Piping interface	Liquid pipe	mm	Φ6.35	Φ6.35	Φ6.35	Φ6.35	Φ6.35	Φ6.35	
	Gas pipe	mm	Φ9.52	Φ9.52	Φ9.52	Φ9.52	Φ12.7	Φ12.7	
Drain pipe	External diameter × thickness	mm	Φ20×1.5	Φ20×1.5	Φ20×1.5	Φ20×1.5	Φ20×1.5	Φ20×1.5	
Dimensions	W×D×H	mm	845×289 ×209	845×289 ×209	845×289 ×209	845×289 ×209	845×289 ×209	970×300 ×224	
Net weight	Main body	kg	10.5	10.5	10.5	10.5	10.5	12.5	

Model			GMV-ND50 G/B4B-T	GMV-ND56 G/B4B-T	GMV-ND63 G/B4B-T	GMV-ND71 G/B4B-T	GMV-ND80 G/B4B-T	GMV-ND90 G/B4B-T	GMV-ND100 G/B4B-T	
Cooling capacity	kW		5.0	5.6	6.3	7.1	8.0	9.0	9.5	
Heating capacity	kW		5.6	6.3	7.1	7.5	9.0	10.0	10.5	
Air volume	m ³ /h		850	1100	1100	1200	1550	1550	1650	
Cooling power input	W		35	50	50	65	80	80	100	
Cooling current input	A		0.17	0.24	0.24	0.31	0.41	0.41	0.41	
Heating power input	W		35	50	50	65	80	80	100	
Heating current input	A		0.17	0.24	0.24	0.31	0.41	0.41	0.41	
*Minimum line current	A		0.15	0.2	0.2	0.2	0.2	0.2	0.2	
*Maximum fuse current	A		6	6	6	6	6	6	6	
Sound pressure level	dB(A)		43	43	43	44	49	49	52	
Power supply			220-240V 1 phase ~50Hz/208-230V 1 phase ~60Hz							
Piping interface	Liquid pipe	mm	Φ6.35	Φ9.52	Φ9.52	Φ9.52	Φ9.52	Φ9.52	Φ9.52	
	Gas pipe	mm	Φ12.7	Φ15.9	Φ15.9	Φ15.9	Φ15.9	Φ15.9	Φ15.9	
Drain pipe	External diameter × thickness	mm	Φ20×1.5	Φ20×1.5	Φ20×1.5	Φ20×1.5	Φ20×1.5	Φ20×1.5	Φ20×1.5	
Dimensions	W×D×H	mm	970×300 ×224	1078×325 ×246	1078×325 ×246	1078×325 ×246	1350×258 ×326	1350×258 ×326	1350×258× 326	
Net weight	Main body	kg	12.5	16	16	16	18.5	18.5	18.5	

Model			GMV-ND22G/C4 B-T	GMV-ND28G/C4 B-T	GMV-ND36G/C4 B-T	GMV-ND45G/C4 B-T
Cooling capacity	kW		2.2	2.8	3.6	4.5
Heating capacity	kW		2.5	3.2	4.0	5.0
Air volume	m ³ /h		500	500	630	850
Cooling power input	W		20	20	25	35
Cooling current input	A		0.1	0.1	0.12	0.17
Heating power input	W		20	20	25	35
Heating current input	A		0.1	0.1	0.12	0.17
*Minimum line current	A		0.1	0.1	0.15	0.15
*Maximum fuse current	A		6	6	6	6
Sound pressure level	dB(A)		35	35	38	43
Power supply			220-240V 1 phase ~50Hz/208-230V 1 phase ~60Hz			
Piping interface	Liquid pipe	mm	Φ6.35	Φ6.35	Φ6.35	Φ6.35
	Gas pipe	mm	Φ9.52	Φ9.52	Φ12.7	Φ12.7
Drain pipe	Outer diameter × Wall thickness	mm	Φ20×1.5	Φ20×1.5	Φ20×1.5	Φ20×1.5
Dimensions W×D×H		mm	845×289×209	845×289×209	845×289×209	970×300×224
Net weight	Main body	kg	10.5	10.5	10.5	12.5

Model			GMV- ND50G/C4B-T	GMV- ND56G/C4B-T	GMV- ND63G/C4B-T	GMV- ND71G/C4B-T
Cooling capacity	kW		5.0	5.6	6.3	7.1
Heating capacity	kW		5.6	6.3	7.1	7.5
Air volume	m ³ /h		850	1100	1100	1200
Cooling power input	W		35	50	50	65
Cooling current input	A		0.17	0.24	0.24	0.31
Heating power input	W		35	50	50	65
Heating current input	A		0.17	0.24	0.24	0.31
*Minimum line current	A		0.15	0.2	0.2	0.2
*Maximum fuse current	A		6	6	6	6
Sound pressure level	dB(A)		43	43	43	44
Power supply			220-240V 1 phase ~50Hz/208-230V 1 phase ~60Hz			
Piping interface	Liquid pipe	mm	Φ6.35	Φ9.52	Φ9.52	Φ9.52
	Gas pipe	mm	Φ12.7	Φ15.9	Φ15.9	Φ15.9
Drain pipe	Outer diameter × Wall thickness	mm	Φ20×1.5	Φ20×1.5	Φ20×1.5	Φ20×1.5
Dimensions W×D×H		mm	970×300×224	1078×325×246	1078×325×246	1078×325×246
Net weight	Main body	kg	12.5	16	16	16

Model			GMV-ND22G/C 2B-T	GMV-ND28G/C 2B-T	GMV-ND36G/C 2B-T	GMV-ND45G/C 2B-T
Cooling capacity	kW		2.2	2.8	3.6	4.5
Heating capacity	kW		2.5	3.2	4.0	5.0
Air volume	m ³ /h		500	500	630	850
Cooling power input	W		20	20	25	35
Cooling current input	A		0.1	0.1	0.12	0.17
Heating power input	W		20	20	25	35
Heating current input	A		0.1	0.1	0.12	0.17
*Minimum line current	A		0.1	0.1	0.15	0.15
*Maximum fuse current	A		6	6	6	6

Model			GMV-ND22G/C 2B-T	GMV-ND28G/C 2B-T	GMV-ND36G/C 2B-T	GMV-ND45G/C 2B-T
Sound pressure level	dB(A)		35	35	38	43
Power supply			220-240V 1 phase ~50Hz/208-230V 1 phase ~60Hz			
Piping interface	Liquid pipe	mm	Φ6.35	Φ6.35	Φ6.35	Φ6.35
	Gas pipe	mm	Φ9.52	Φ9.52	Φ12.7	Φ12.7
Drain pipe	Outer diameter × Wall thickness	mm	Φ20×1.5	Φ20×1.5	Φ20×1.5	Φ20×1.5
Dimensions W×D×H		mm	845×289×209	845×289×209	845×289×209	970×300×224
Net weight	Main body	kg	10.5	10.5	10.5	12.5

Model			GMV- ND50G/C2B-T	GMV- ND56G/C2B-T	GMV- ND63G/C2B-T	GMV- ND71G/C2B-T
Cooling capacity	kW		5.0	5.6	6.3	7.1
Heating capacity	kW		5.6	6.3	7.1	7.5
Air volume	m³/h		850	1100	1100	1200
Cooling power input	W		35	50	50	65
Cooling current input	A		0.17	0.24	0.24	0.31
Heating power input	W		35	50	50	65
Heating current input	A		0.17	0.24	0.24	0.31
*Minimum line current	A		0.15	0.2	0.2	0.2
*Maximum fuse current	A		6	6	6	6
Sound pressure level	dB(A)		43	43	43	44
Power supply			220-240V 1 phase ~50Hz/208-230V 1 phase ~60Hz			
Piping interface	Liquid pipe	mm	Φ6.35	Φ9.52	Φ9.52	Φ9.52
	Gas pipe	mm	Φ12.7	Φ15.9	Φ15.9	Φ15.9
Drain pipe	Outer diameter × Wall thickness	mm	Φ20×1.5	Φ20×1.5	Φ20×1.5	Φ20×1.5
Dimensions W×D×H		mm	970×300×224	1078×325×246	1078×325×246	1078×325×246
Net weight	Main body	kg	12.5	16	16	16

Model			GMV-ND22G/D2 B-T	GMV-ND28G/D2 B-T	GMV-ND36G/D2 B-T	GMV-ND45G/D2 B-T
Cooling capacity	kW		2.2	2.8	3.6	4.5
Heating capacity	kW		2.5	3.2	4.0	5.0
Air volume	m³/h		500	500	630	850
Cooling power input	W		20	20	25	35
Cooling current input	A		0.1	0.1	0.12	0.17
Heating power input	W		20	20	25	35
Heating current input	A		0.1	0.1	0.12	0.17
*Minimum line current	A		0.1	0.1	0.15	0.15
*Maximum fuse current	A		6	6	6	6
Sound pressure level	dB(A)		35	35	38	43
Power supply			220-240V 1 phase ~50Hz/208-230V 1 phase ~60Hz			
Piping interface	Liquid pipe	mm	Φ6.35	Φ6.35	Φ6.35	Φ6.35
	Gas pipe	mm	Φ9.52	Φ9.52	Φ12.7	Φ12.7
Drain pipe	Outer diameter × Wall thickness	mm	Φ20×1.5	Φ20×1.5	Φ20×1.5	Φ20×1.5
Dimensions	W×D×H	mm	845×289×209	845×289×209	845×289×209	970×300×224
Net weight	Main body	kg	10.5	10.5	10.5	12.5

Model		GMV-ND50G/D 2B-T	GMV-ND56G/D 2B-T	GMV-ND63G/D 2B-T	GMV-ND71G/D2 B-T	
Cooling capacity	kW	5.0	5.6	6.3	7.1	
Heating capacity	kW	5.6	6.3	7.1	7.5	
Air volume	m ³ /h	850	1100	1100	1200	
Cooling power input	W	35	50	50	65	
Cooling current input	A	0.17	0.24	0.24	0.31	
Heating power input	W	35	50	50	65	
Heating current input	A	0.17	0.24	0.24	0.31	
*Minimum line current	A	0.15	0.2	0.2	0.2	
*Maximum fuse current	A	6	6	6	6	
Sound pressure level	dB(A)	43	43	43	44	
Power supply		220-240V 1 phase ~50Hz/208-230V 1 phase ~60Hz				
Piping interface	Liquid pipe	mm	Φ6.35	Φ9.52	Φ9.52	Φ9.52
	Gas pipe	mm	Φ12.7	Φ15.9	Φ15.9	Φ15.9
Drain pipe	Outer diameter × Wall thickness	mm	Φ20×1.5	Φ20×1.5	Φ20×1.5	Φ20×1.5
Dimensions	W×D×H	mm	970×300×224	1078×325×246	1078×325×246	1078×325×246
Net weight	Main body	kg	12.5	16	16	16

Notes:

- ① Rated Cooling capacity test conditions: indoor 27°C DB/19°C WB, outdoor 35°C DB; connection pipe length: 5 m, without height drop between units.
- ② Rated heating capacity test conditions: indoor 20°C DB, outdoor 7°C DB/6 °C WB; connection pipe length: 5 m, without height drop between units.

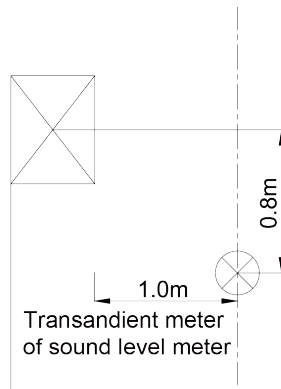
**3.15 Super High Static Pressure Duct Type Indoor Unit**

Model		GMV-ND22 PHS/B-T	GMV-ND25 PHS/B-T	GMV-ND28 PHS/B-T	GMV-ND32 PHS/B-T	GMV-ND36 PHS/B-T	GMV-ND40 PHS/B-T
Cooling capacity	kW	2.2	2.5	2.8	3.2	3.6	4
Heating capacity	kW	2.5	2.8	3.2	3.6	4	4.5
Air Volume	m ³ /h	550	550	550	600	600	850
External Static Pressure	Pa	60/0~150	60/0~150	60/0~150	60/0~150	60/0~150	60/0~150
Cooling power input	W	55	55	55	65	65	85
Cooling current input	A	0.5	0.5	0.5	0.5	0.5	0.5
Heating power input	W	55	55	55	65	65	85
Heating current input	A	0.5	0.5	0.5	0.5	0.5	0.5
Minimum line current	A	0.375	0.375	0.375	0.375	0.375	0.5
Maximum fuse current	A	6	6	6	6	6	6
Sound pressure level	dB(A)	33	33	33	33	33	36
Power supply		220-240V 1 phase ~50Hz/208-230V 1 phase ~60Hz					
Pipe diameter	Liquid pipe	mm	Φ6.35	Φ6.35	Φ6.35	Φ6.35	Φ6.35
	Gas pipe	mm	Φ9.52	Φ9.52	Φ9.52	Φ12.7	Φ12.7

Model			GMV-ND22 PHS/B-T	GMV-ND25 PHS/B-T	GMV-ND28 PHS/B-T	GMV-ND32 PHS/B-T	GMV-ND36 PHS/B-T	GMV-ND40 PHS/B-T
Drain pipe	External diameter×thickness	mm	Φ25×2.5	Φ25×2.5	Φ25×2.5	Φ25×2.5	Φ25×2.5	Φ25×2.5
Outline Dimensions	W×D×H	mm	700×700 ×300	700×700 ×300	700×700 ×300	700×700 ×300	700×700 ×300	700×700 ×300
Net weight		kg	32	32	32	32	32	34

Model			GMV-ND45 PHS/B-T	GMV-ND50 PHS/B-T	GMV-ND56 PHS/B-T	GMV-ND63 PHS/B-T	GMV-ND71 PHS/B-T	GMV-ND80 PHS/B-T	
Cooling capacity	kW		4.5	5.0	5.6	6.3	7.1	8.0	
Heating capacity	kW		5.0	5.6	6.3	7.1	8.0	9.0	
Air Volume	m ³ /h		850	850	1000	1000	1250	1250	
External Static Pressure	Pa		60/0~150	60/0~150	90/0~200	90/0~200	90/0~200	90/0~200	
Cooling power input	W		85	85	90	90	100	100	
Cooling current input	A		0.5	0.5	0.8	0.8	0.8	0.8	
Heating power input	W		85	85	90	90	100	100	
Heating current input	A		0.5	0.5	0.8	0.8	0.8	0.8	
Minimum line current	A		0.5	0.5	0.5	0.5	0.5	0.5	
Maximum fuse current	A		6	6	6	6	6	6	
Sound pressure level	dB(A)		36	36	37	37	38	38	
Power supply			220-240V 1 phase ~50Hz/208-230V 1 phase ~60Hz						
Pipe diameter	Liquid pipe	mm	Φ6.35	Φ6.35	Φ9.52	Φ9.52	Φ9.52	Φ9.52	
	Gas pipe	mm	Φ12.7	Φ12.7	Φ15.9	Φ15.9	Φ15.9	Φ15.9	
Drain pipe	External diameter ×thickness	mm	Φ25×2.5	Φ25×2.5	Φ25×2.5	Φ25×2.5	Φ25×2.5	Φ25×2.5	
Outline Dimensions	W×D×H	mm	700×700 ×300	700×700 ×300	1000×700 ×300	1000×700 ×300	1000×700 ×300	1000×700 ×300	
Net weight		kg	34	34	43	43	43	43	

Model			GMV-ND90 PHS/B-T	GMV-ND10 0PHS/B-T	GMV-ND11 2PHS/B-T	GMV-ND12 5PHS/B-T	GMV-ND14 0PHS/B-T	GMV-ND16 0PHS/B-T	
Cooling capacity	kW		9.0	10.0	11.2	12.5	14.0	16.0	
Heating capacity	kW		10.0	11.2	12.5	14.0	16.0	18.0	
Air Volume	m ³ /h		1800	1800	2000	2000	2350	2500	
External Static Pressure	Pa		90/0~200	90/0~200	90/0~200	90/0~200	90/0~200	90/0~200	
Cooling power input	W		140	140	160	160	220	230	
Cooling current input	A		1.1	1.1	1.1	1.1	1.5	1.5	
Heating power input	W		140	140	160	160	220	230	
Heating current input	A		1.1	1.1	1.1	1.1	1.5	1.5	
Minimum line current	A		0.75	0.75	0.875	0.875	1.25	1.25	
Maximum fuse current	A		6	6	6	6	6	6	
Sound pressure level	dB(A)		40	40	40	40	42	44	
Power supply			220-240V 1 phase ~50Hz/208-230V 1 phase ~60Hz						
Pipe diameter	Liquid pipe	mm	Φ9.52	Φ9.52	Φ9.52	Φ9.52	Φ9.52	Φ9.52	
	Gas pipe	mm	Φ15.9	Φ15.9	Φ15.9	Φ15.9	Φ15.9	Φ19.05	
Drain pipe	External diameter ×thickness	mm	Φ25×2.5	Φ25×2.5	Φ25×2.5	Φ25×2.5	Φ25×2.5	Φ25×2.5	
Outline Dimensions	W×D×H	mm	1400×700 ×300	1400×700 ×300	1400×700 ×300	1400×700 ×300	1400×700 ×300	1400×700 ×300	
Net weight		kg	57	57	57	57	58	58	

Model			GMV-ND180PHS/B-T
Cooling capacity	kW		18.0
Heating capacity	kW		20.0
Air Volume	m ³ /h		3000
External Static Pressure	Pa		90/0~170
Cooling power input	W		350
Cooling current input	A		2.0
Heating power input	W		350
Heating current input	A		2.0
Minimum line current	A		3.39
Maximum fuse current	A		6
Sound pressure level	dB(A)		49
Power supply			220-240V 1 phase ~50Hz/208-230V 1 phase ~60Hz
Pipe diameter	Liquid pipe	mm	Φ9.52
	Gas pipe	mm	Φ19.05
Drain pipe	External diameter ×thickness	mm	Φ25×2.5
Outline Dimensions	W×D×H	mm	1400×700 ×300
Net weight			kg 58

Model			GMV-ND400PH/AR-X	GMV-ND450PH/AR-X	GMV-N560PH/AR-M
Cooling capacity	kW		40.0	45.0	56.0
Heating capacity	kW		45.0	50.0	63.0
Air Volume	m ³ /h		8000	8200	10000
External Static Pressure	Pa		200/50~250	200/50~250	200
Cooling power input	W		2500	2550	2700
Cooling current input	A		2.7	4.1	5.5
Heating power input	W		2500	2550	2700
Heating current input	A		2.7	4.1	5.5
Minimum line current	A		/	/	/
Maximum fuse current	A		/	/	/
Sound pressure level	dB(A)		61	62	63
Power supply			380-415V 3 phase ~50/60Hz	380V 3 phase ~50Hz	
Pipe diameter	Liquid pipe	mm	Φ12.7	Φ12.7	Φ15.9
	Gas pipe	mm	Φ25.4	Φ28.6	Φ28.6
Drain pipe	External diameter ×thickness	mm	Φ25×1.2	Φ25×1.2	Φ25×1.2
Outline Dimensions	W×D×H	mm	1680×900×650	1900×1100×700	1900×1100×850
Net weight			kg 170	236	282

Notes:

- ① Rated cooling capacity test conditions: indoor 27°C DB/19°C WB, outdoor 35°C DB; connection pipe length: 5 m, without height drop between units.
- ② Rated heating capacity test conditions: indoor 20°C DB, outdoor 7°C DB/6 °C WB; connection pipe length: 5 m, without height drop between units.
- ③ In the column of "Unit external static pressure": The figure before "/" indicates the default external static pressure of unit before delivery, and the figures after indicate the adjustable

static pressure range of unit.

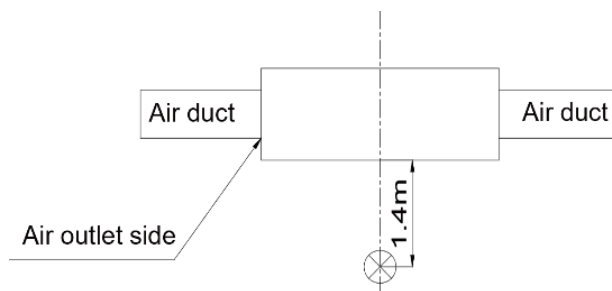

Transducer meter of sound level meter

3.16 AHU-KIT Type

Model			GMV-N36U/A-T			GMV-N71U/A-T			GMV-N140U/A-T		
Defaulted capacity of ex-factory	Capacity		36			71			140		
	Cooling	kW	3.6			7.1			14.0		
	Heating	kW	4.0			8.0			16.0		
Adjustable capacity	Capacity		28	36	45	56	71	90	112	140	
	Cooling	kW	2.8	3.6	4.5	5.6	7.1	9.0	11.2	14.0	
	Heating	kW	3.2	4.0	5.0	6.3	8.0	10.0	12.5	16.0	
Power input		W	5.0			5.0			5.0		
Power Supply			220-240V 1 phase ~50Hz/208-230V 1 phase ~60Hz								
Size of connection pipe	AHU-KIT (ex-factory pipe size)		mm	Φ6.35	Φ6.35	Φ9.52	Φ9.52	Φ9.52	Φ9.52	Φ9.52	Φ9.52
	AHU	Liquid pipe	mm	Φ6.35	Φ6.35	Φ6.35	Φ9.52	Φ9.52	Φ9.52	Φ9.52	Φ9.52
		Gas pipe	mm	Φ9.52	Φ12.7	Φ12.7	Φ15.9	Φ15.9	Φ15.9	Φ15.9	Φ15.9
	Connection method			Brazing Connection			Brazing Connection			Brazing Connection	
Outline dimension (W×D×H)	EXV box	mm	203×326×85			203×326×85			203×326×85		
	Control box	mm	334×284×111			334×284×111			334×284×111		
Packing size(W×D×H)		mm	539×461×247			539×461×247			539×461×247		
Net weight		kg	8.6			8.6			8.6		

Model			GMV-N280U/A-T					GMV-N560U/A-T			
Defaulted capacity of ex-factory	Capacity		280					560			
	Cooling	kW	28.0					56.0			
	Heating	kW	31.5					63.0			
Adjustable capacity	Capacity		224	280	335	400	450	504	560	840	
	Cooling	kW	22.4	28.0	33.5	40.0	45.0	50.4	56.0	84.0	
	Heating	kW	25.0	31.5	37.5	45.0	50.00	56.5	63.0	94.5	
Power input		W	5.0					5.0			
Power Supply			220-240V 1 phase ~50Hz/208-230V 1 phase ~60Hz								
Size of connection pipe	AHU-KIT (ex-factory pipe size)		mm	Φ9.52	Φ9.52	Φ9.52	Φ9.52	Φ9.52	Φ15.9	Φ15.9	Φ15.9
	AHU	Liquid pipe	mm	Φ9.52	Φ9.52	Φ12.7	Φ12.7	Φ12.7	Φ15.9	Φ15.9	Φ19.05
		Gas pipe	mm	Φ19.05	Φ22.2	Φ25.4	Φ25.4	Φ28.6	Φ28.6	Φ28.6	Φ31.8
	Connection method			Brazing Connection					Brazing Connection		
Outline dimension (W×D×H)	EXV box	mm	203×326×85					246×500×120			
	Control box	mm	334×284×111					334×284×111			
Packing size(W×D×H)		mm	539×461×247					759×645×180			
Net weight		kg	8.6					11.8			

Model(Combined)				GMV-N560U/A-T+ GMV-N140U/A-T	GMV-N560U/A-T+ GMV-N280U/A-T	GMV-N560U/A-T+ GMV-N560U/A-T	
Capacity	-			840+140	840+280	840+560	840+840
Cooling	kW			98	112	140	168
Heating	kW			110.5	126	157.5	189
Power input	W			5+5	5+5	5+5	
Power Supply				220-240V 1 phase ~50Hz/208-230V 1 phase ~60Hz			
Size of connection pipe	AHU	Liquid pipe	mm	Φ19.05	Φ19.05	Φ19.05	Φ19.05
		Gas pipe	mm	Φ38.1	Φ38.1	Φ41.3	Φ41.3
Outline dimension (W×D×H)	EXV box		mm	246×500×120+203×326×85	246×500×120+203×326×85	(246×500×120)×2	
	Control box		mm	(334×284×111)×2	(334×284×111)×2	(334×284×111)×2	
Net weight			kg	11.8+8.6	11.8+8.6	11.8+11.8	

Model				GMV-N36U/B-T		GMV-N71U/B-T			GMV-N140U/B-T		
Defaulted capacity of ex-factory	Capacity			36		71			140		
	Cooling	kW		3.6		7.1			14.0		
	Heating	kW		4.0		8.0			16.0		
Adjustable capacity	Capacity			28	36	45	56	71	90	112	140
	Cooling	kW		2.8	3.6	4.5	5.6	7.1	9.0	11.2	14.0
	Heating	kW		3.2	4.0	5.0	6.3	8.0	10.0	12.5	16.0
Power input			W		8.0		8.0			8.0	
Power Supply				220-240V 1 phase ~50Hz/208-230V 1 phase ~60Hz							
Size of connection pipe	AHU-KIT (ex-factory pipe size)		mm	Φ6.35	Φ6.35	Φ9.52	Φ9.52	Φ9.52	Φ9.52	Φ9.52	Φ9.52
	AHU	Liquid pipe	mm	Φ6.35	Φ6.35	Φ6.35	Φ9.52	Φ9.52	Φ9.52	Φ9.52	Φ9.52
		Gas pipe	mm	Φ9.52	Φ12.7	Φ12.7	Φ15.9	Φ15.9	Φ15.9	Φ15.9	Φ15.9
	Connection method			Brazing Connection		Brazing Connection			Brazing Connection		
Outline dimension (W×D×H)	EXV box		mm	203×326×85		203×326×85			203×326×85		
	Control box		mm	334×284×111		334×284×111			334×284×111		
Packing size(W×D×H)			mm		539×461×247			539×461×247			
Net weight			kg		9.5		10.0			10.0	

Model				GMV-N280U/B-T					GMV-N560U/B-T			
Defaulted capacity of ex-factory	Capacity			280					560			
	Cooling	kW		28.0					56.0			
	Heating	kW		31.5					63.0			
Adjustable capacity	Capacity			224	280	335	400	450	504	560	840	
	Cooling	kW		22.4	28.0	33.5	40.0	45.0	50.4	56.0	84.0	
	Heating	kW		25.0	31.5	37.5	45.0	50.0	56.5	63.0	94.5	
Power input			W		8.0					8.0		
Power Supply				220-240V 1 phase ~50Hz/208-230V 1 phase ~60Hz								
Size of connection pipe	AHU-KIT (ex-factory pipe size)		mm	Φ9.52	Φ9.52	Φ9.52	Φ9.52	Φ9.52	Φ15.9	Φ15.9	Φ15.9	
	AHU	Liquid pipe	mm	Φ9.52	Φ9.52	Φ12.7	Φ12.7	Φ12.7	Φ15.9	Φ15.9	Φ19.05	
		Gas pipe	mm	Φ19.05	Φ22.2	Φ25.4	Φ25.4	Φ28.6	Φ28.6	Φ28.6	Φ31.8	
	Connection method			Brazing Connection					Brazing Connection			
Outline dimension (W×D×H)	EXV box		mm	203×326×85					246×500×120			
	Control box		mm	334×284×111					334×284×111			
Packing size(W×D×H)			mm		539×461×247					759×645×180		
Net weight			kg		10.0					12.5		

Model(Combined)		GMV-N560U/B-T+ GMV-N140U/B-T	GMV-N560U/B-T+ GMV-N280U/B-T	GMV-N560U/B-T+ GMV-N560U/B-T			
Capacity	-	840+140	840+280	840+560	840+840		
Cooling	kW	98	112	140	168		
Heating	kW	110.5	126	157.5	189		
Power input	W	8+8	8+8	8+8			
Power Supply		220-240V 1 phase ~50Hz/208-230V 1 phase ~60Hz					
Size of connection pipe	AHU	Liquid pipe	mm	Φ19.05	Φ19.05	Φ19.05	Φ19.05
		Gas pipe	mm	Φ38.1	Φ38.1	Φ41.3	Φ41.3
Outline dimension (W×D×H)	EXV box	mm	246×500×120+203×326×85	246×500×120+203×326×85	(246×500×120)×2		
	Control box	mm	(334×284×111)×2	(334×284×111)×2	(334×284×111)×2		
Net weight	kg	12.5+10.0	12.5+10.0	12.5+12.5			

Model		GMV-N36U/C-T	GMV-N71U/C-T			GMV-N140U/C-T					
Defaulted capacity of ex- factory	Capacity	36	71			140					
	Cooling	kW	3.6	7.1			14				
	Heating	kW	4	8			16				
Adjustable capacity	Capacity	28	36	45	56	71	90	112	140		
	Cooling	kW	2.8	3.6	4.5	5.6	7.1	9	11.2	14	
	Heating	kW	3.2	4	5	6.3	8	10	12.5	16	
Power input	W	8			8			8			
Power Supply		220-240V 1 phase ~50Hz/208-230V 1 phase ~60Hz									
Size of connection pipe	AHU-KIT (ex-factory pipe size)		mm	Φ6.35	Φ6.35	Φ9.52	Φ9.52	Φ9.52	Φ9.52	Φ9.52	Φ9.52
	Air handling unit	Liquid pipe	mm	Φ6.35	Φ6.35	Φ6.35	Φ9.52	Φ9.52	Φ9.52	Φ9.52	Φ9.52
		Gas pipe	mm	Φ9.52	Φ12.7	Φ12.7	Φ15.9	Φ15.9	Φ15.9	Φ15.9	Φ15.9
	Connection method		Brazing Connection			Brazing Connection			Brazing Connection		
Outline dimension (W×D×H)	EXV box	mm	203×326×85			203×326×85			203×326×85		
	Control box	mm	334×284×111			334×284×111			334×284×111		
Packing size (W×D×H)	mm	539×461×247			539×461×247			539×461×247			
Net weight	kg	10.0			10.5			10.5			

Model		GMV-N280U/C-T					GMV-N560U/C-T				
Defaulted capacity of ex- factory	Capacity	280					560				
	Cooling	kW	28					56			
	Heating	kW	31.5					63			
Adjustable capacity	Capacity	224	280	335	400	450	504	560	840		
	Cooling	kW	22.4	28	33.5	40	45	50.4	56	84	
	Heating	kW	25	31.5	37.5	45	50	56.5	63	94.5	
Power input	W	8					8				
Power Supply		220-240V 1 phase ~50Hz/208-230V 1 phase ~60Hz									
Size of connection pipe	AHU-KIT (ex-factory pipe size)		mm	Φ9.52	Φ9.52	Φ9.52	Φ9.52	Φ9.52	Φ15.9	Φ15.9	Φ15.9
	Air handling unit	Liquid pipe	mm	Φ9.52	Φ9.52	Φ12.7	Φ12.7	Φ12.7	Φ15.9	Φ15.9	Φ19.05
		Gas pipe	mm	Φ19.05	Φ22.2	Φ25.4	Φ25.4	Φ28.6	Φ28.6	Φ28.6	Φ31.8
	Connection method		Brazing Connection					Brazing Connection			
Outline dimension (W×D×H)	EXV box	mm	203×326×85					246×500×120			
	Control box	mm	334×284×111					334×284×111			
Packing size (W×D×H)	mm	539×461×247					759×645×180				

Model		GMV-N280U/C-T	GMV-N560U/C-T
Net weight	kg	10.5	13.0

Model(Combined)			GMV-N560U/C-T +GMV-N140U/C-T	GMV-N560U/C-T +GMV-N280U/C-T	GMV-N560U/C-T +GMV-N560U/C-T
Capacity			840+140	840+280	840+560 840+840
Cooling	kW		98	112	140 168
Heating	kW		110.5	126	157.5 189
Power input	W		8+8	8+8	8+8
Power Supply			220-240V 1 phase ~50Hz/208-230V 1 phase ~60Hz		
Size of connection pipe	Air handling unit	Liquid pipe	Φ19.05	Φ19.05	Φ19.05 Φ19.05
		Gas pipe	Φ38.1	Φ38.1	Φ41.3 Φ41.3
Outline dimension (W×D×H)	EXV box	mm	246×500×120 +203×326×85	246×500×120 +203×326×85	(246×500×120)×2
	Control box	mm	(334×284×111)×2	(334×284×111)×2	(334×284×111)×2
Net weight	kg		13.0+10.5	13.0+10.5	13.0+13.0

Model(Combined)			GMV-N560U/C-T +GMV-N560U/C-T +GMV-N140U/C-T	GMV-N560U/C-T +GMV-N560U/C-T +GMV-N280U/C-T	GMV-N560U/C-T +GMV-N560U/C-T +GMV-N560U/C-T
Capacity			840+840+140	840+840+280	840+840 +560 840+840 +840
Cooling	kW		182	196	224 252
Heating	kW		204.5	220.5	252 283.5
Power input	W		8+8+8	8+8+8	8+8+8
Power Supply			220-240V 1 phase ~50Hz/208-230V 1 phase ~60Hz		
Size of connection pipe	Air handling unit	Liquid pipe	Φ19.05	Φ22.2	Φ22.2 Φ22.2
		Gas pipe	Φ41.3	Φ44.5	Φ44.5 Φ44.5
Outline dimension (W×D×H)	EXV box	mm	(246×500×120)×2 +203×326×85	(246×500×120)×2 +203×326×85	(246×500×120)×3
	Control box	mm	(334×284×111)×3	(334×284×111)×3	(334×284×111)×3
Net weight	kg		13.0+13.0+10.5	13.0+13.0+10.5	13.0+13.0+13.0

3.17 Concealed Floor Standing Type

Model		GMV-ND22 ZA/A-T	GMV-ND28 ZA/A-T	GMV-ND36 ZA/A-T	GMV-ND45 ZA/A-T	GMV-ND56 ZA/A-T	GMV-ND63 ZA/A-T	GMV-ND71 ZA/A-T
Cooling capacity	kW	2.2	2.8	3.6	4.5	5.6	6.3	7.1
Heating capacity	kW	2.5	3.2	4.0	5.0	6.3	7.1	8.0
Air Volume	m ³ /h	450	450	550	650	900	900	1100
External Static Pressure	Pa	10/0~40	10/0~40	10/0~40	15/0~60	15/0~60	15/0~60	15/0~60
Cooling power input	W	35	35	43	45	80	80	90
Cooling current input	A	0.18	0.18	0.22	0.23	0.41	0.41	0.46
Heating power input	W	35	35	43	45	80	80	90
Heating current input	A	0.18	0.18	0.22	0.23	0.41	0.41	0.46
Minimum line current	A	0.2	0.2	0.3	0.3	0.5	0.5	0.5
Maximum fuse current	A	6	6	6	6	6	6	6
Sound pressure level	dB(A)	30	30	33	33	35	35	37
Power supply		220-240V 1 phase ~50Hz/208-230V 1 phase ~60Hz						
Pipe diameter	Liquid pipe	mm	Φ6.35	Φ6.35	Φ6.35	Φ6.35	Φ9.52	Φ9.52 Φ9.52
	Gas pipe	mm	Φ9.52	Φ9.52	Φ12.7	Φ12.7	Φ15.9	Φ15.9 Φ15.9
Drain pipe	External diameter × thickness	mm	Φ25×2.5	Φ25×2.5	Φ25×2.5	Φ25×2.5	Φ25×2.5	Φ25×2.5

Model			GMV-ND22 ZA/A-T	GMV-ND28 ZA/A-T	GMV-ND36 ZA/A-T	GMV-ND45 ZA/A-T	GMV-ND56 ZA/A-T	GMV-ND63 ZA/A-T	GMV-ND71 ZA/A-T
Outline Dimensions	W×D×H	mm	700×615 ×200	700×615 ×200	700×615 ×200	900×615 ×200	1100×615 ×200	1100×615 ×200	1100×615 ×200
Net weight		kg	23	23	23	27	32	32	32

Notes:

- ① Rated cooling capacity test conditions: indoor 27°C DB/19°C WB, outdoor 35°C DB; connection pipe length: 5m, without height drop between units.
- ② Rated heating capacity test conditions: indoor 20°C DB, outdoor 7°C DB/6 °C WB; connection pipe length: 5m, without height drop between units.
- ③ In the column of “Unit external static pressure”: The figure before “/” indicates the default external static pressure of unit before delivery, and the figures after indicate the adjustable static pressure range of unit.

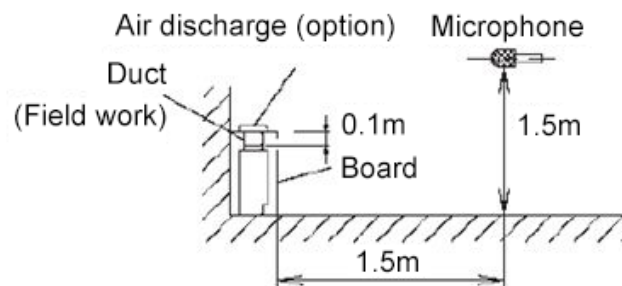

Transient meter of sound level meter

3.18 360° Air Discharge Cassette

Model			GMV-ND22T/C-T	GMV-ND28T/C-T	GMV-ND36T/C-T	GMV-ND45T/C-T
Cooling capacity	kW		2.2	2.8	3.6	4.5
Heating capacity	kW		2.5	3.2	4	5
Air volume(H/M/L)	m ³ /h		800/700/600	800/700/600	800/700/600	800/700/600
Cooling power input	W		26	26	26	26
Cooling current input	A		0.2	0.2	0.2	0.2
Heating power input	W		22	22	22	22
Heating current input	A		0.2	0.2	0.2	0.2
Minimum line current	A		0.50	0.50	0.50	0.50
Maximum fuse current	A		6	6	6	6
Sound Pressure Level (H/M/L)	dB(A)		33/30/28	33/30/28	33/30/28	34/30/28
Power supply			220-240V 1 phase ~50Hz/208-230V 1 phase ~60Hz			
Piping interface	Liquid pipe	mm	Φ6.35	Φ6.35	Φ6.35	Φ6.35
	Gas pipe	mm	Φ9.52	Φ9.52	Φ12.7	Φ12.7
Drain pipe	External diameter×Thickness	mm	Φ25×2.5	Φ25×2.5	Φ25×2.5	Φ25×2.5
Main body dimensions	W×D×H	mm	840×840×240	840×840×240	840×840×240	840×840×240
Panel dimensions	W×D×H	mm	950×950×65	950×950×65	950×950×65	950×950×65
Net weight	Main body	kg	27	27	27	27
	Panel	kg	6	6	6	6

Model			GMV-ND22T/C-T	GMV-ND28T/C-T	GMV-ND36T/C-T	GMV-ND45T/C-T
Panel model		/	TF06	TF06	TF06	TF06
Loading Quantity	40' GP	set	120	120	120	120
	40' HQ	set	140	140	140	140

Model			GMV-ND50T/C-T	GMV-ND56T/C-T	GMV-ND63T/C-T	GMV-ND71T/C-T
Cooling capacity		kW	5	5.6	6.3	7.1
Heating capacity		kW	5.6	6.3	7.1	8
Air volume(H/M/L)		m ³ /h	900/800/700	950/850/750	1150/950/850	1150/950/850
Cooling power input		W	28	35	60	60
Cooling current input		A	0.2	0.2	0.4	0.4
Heating power input		W	25	35	56	56
Heating current input		A	0.2	0.2	0.4	0.4
Minimum line current		A	0.50	0.50	0.55	0.55
Maximum fuse current		A	6	6	6	6
Sound Pressure Level (H/M/L)		dB(A)	35/32/29	37/33/30	37/34/31	37/34/31
Power supply			220-240V 1 phase ~50Hz/208-230V 1 phase ~60Hz			
Piping interface	Liquid pipe	mm	Φ6.35	Φ9.52	Φ9.52	Φ9.52
	Gas pipe	mm	Φ12.7	Φ15.9	Φ15.9	Φ15.9
Drain pipe	External diameter×Thickness	mm	φ25×2.5	φ25×2.5	φ25×2.5	φ25×2.5
Main body dimensions	W×D×H	mm	840×840×240	840×840×240	840×840×240	840×840×240
Panel dimensions	W×D×H	mm	950×950×65	950×950×65	950×950×65	950×950×65
Net weight	Main body	kg	28	28	28	28
	Panel	kg	6	6	6	6
Panel model		/	TF06	TF06	TF06	TF06
Loading Quantity	40' GP	set	120	120	120	120
	40' HQ	set	140	140	140	140

Model			GMV-ND80T/C-T	GMV-ND90T/C-T	GMV-ND100T/C-T	GMV-ND112T/C-T
Cooling capacity		kW	8	9	10	11.2
Heating capacity		kW	9	10	11.2	12.5
Air volume(H/M/L)		m ³ /h	1250/1000/900	1250/1000/900	1250/1000/900	1650/1300/1100
Cooling power input		W	80	80	80	115
Cooling current input		A	0.4	0.4	0.4	0.6
Heating power input		W	76	76	76	111
Heating current input		A	0.4	0.4	0.4	0.6
Minimum line current		A	0.55	0.55	0.55	0.98
Maximum fuse current		A	6	6	6	6
Sound Pressure Level (H/M/L)		dB(A)	39/37/34	39/37/34	39/37/34	43/41/39
Power supply			220-240V 1 phase ~50Hz/208-230V 1 phase ~60Hz			

Model			GMV-ND80T/C-T	GMV-ND90T/C-T	GMV-ND100T/C-T	GMV-ND112T/C-T
Piping interface	Liquid pipe	mm	Φ9.52	Φ9.52	Φ9.52	Φ9.52
	Gas pipe	mm	Φ15.9	Φ15.9	Φ15.9	Φ15.9
Drain pipe	External diameter×Thickness	mm	Φ25×2.5	Φ25×2.5	Φ25×2.5	Φ25×2.5
Main body dimensions	W×D×H	mm	840×840×240	840×840×240	840×840×240	840×840×290
Panel dimensions	W×D×H	mm	950×950×65	950×950×65	950×950×65	950×950×65
Net weight	Main body	kg	29	29	29	33
	Panel	kg	6	6	6	6
Panel model		/	TF06	TF06	TF06	TF06
Loading Quantity	40' GP	set	120	120	120	120
	40' HQ	set	140	140	140	140

Model			GMV-ND125T/C-T	GMV-ND140T/C-T
Cooling capacity	kW		12.5	14
Heating capacity	kW		14	16
Air volume(H/M/L)	m ³ /h		1650/1300/1100	1650/1300/1100
Cooling power input	W		115	115
Cooling current input	A		0.6	0.6
Heating power input	W		111	111
Heating current input	A		0.6	0.6
Minimum line current	A		0.98	0.98
Maximum fuse current	A		6	6
Sound Pressure Level (H/M/L)	dB(A)		43/41/39	43/41/39
Power supply			220-240V 1 phase ~50Hz/208-230V 1 phase ~60Hz	
Piping interface	Liquid pipe	mm	Φ9.52	Φ9.52
	Gas pipe	mm	Φ15.9	Φ15.9
Drain pipe	External diameter×Thickness	mm	Φ25×2.5	Φ25×2.5
Main body dimensions	W×D×H	mm	840×840×290	840×840×290
Panel dimensions	W×D×H	mm	950×950×65	950×950×65
Net weight	Main body	kg	33	33
	Panel	kg	6	6
Panel model		/	TF06	TF06
Loading Quantity	40' GP	set	120	120
	40' HQ	set	140	140

Notes:

- ① Rated cooling capacity test conditions: indoor 27°C DB/19°C WB, outdoor 35°C DB; connection pipe length: 5 m, without height drop between units.
- ② Rated heating capacity test conditions: indoor 20°C DB, outdoor 7°C DB/6 °C WB; connection pipe length: 5 m, without height drop between units.

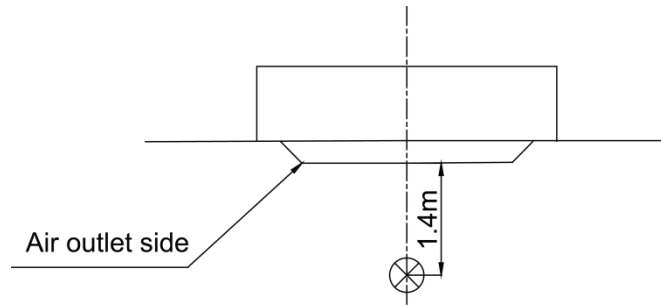

Transducer of sound level meter

3.19 Heat Storage Module

Model		XRZ180L/A-T	
power input	W	5	
current input	A	0.05	
Maximum fuse current	A	6	
Power supply		220-240V 1 phase ~50Hz/208-230V 1 phase ~60Hz	
Piping interface	Liquid pipe	mm	Φ6.35
	Gas pipe	mm	Φ12.7
Outline Dimensions (WxDxH)	mm	730×450×220	
Net weight	kg	31.5	

CONTROL

1 Operation Flowchart

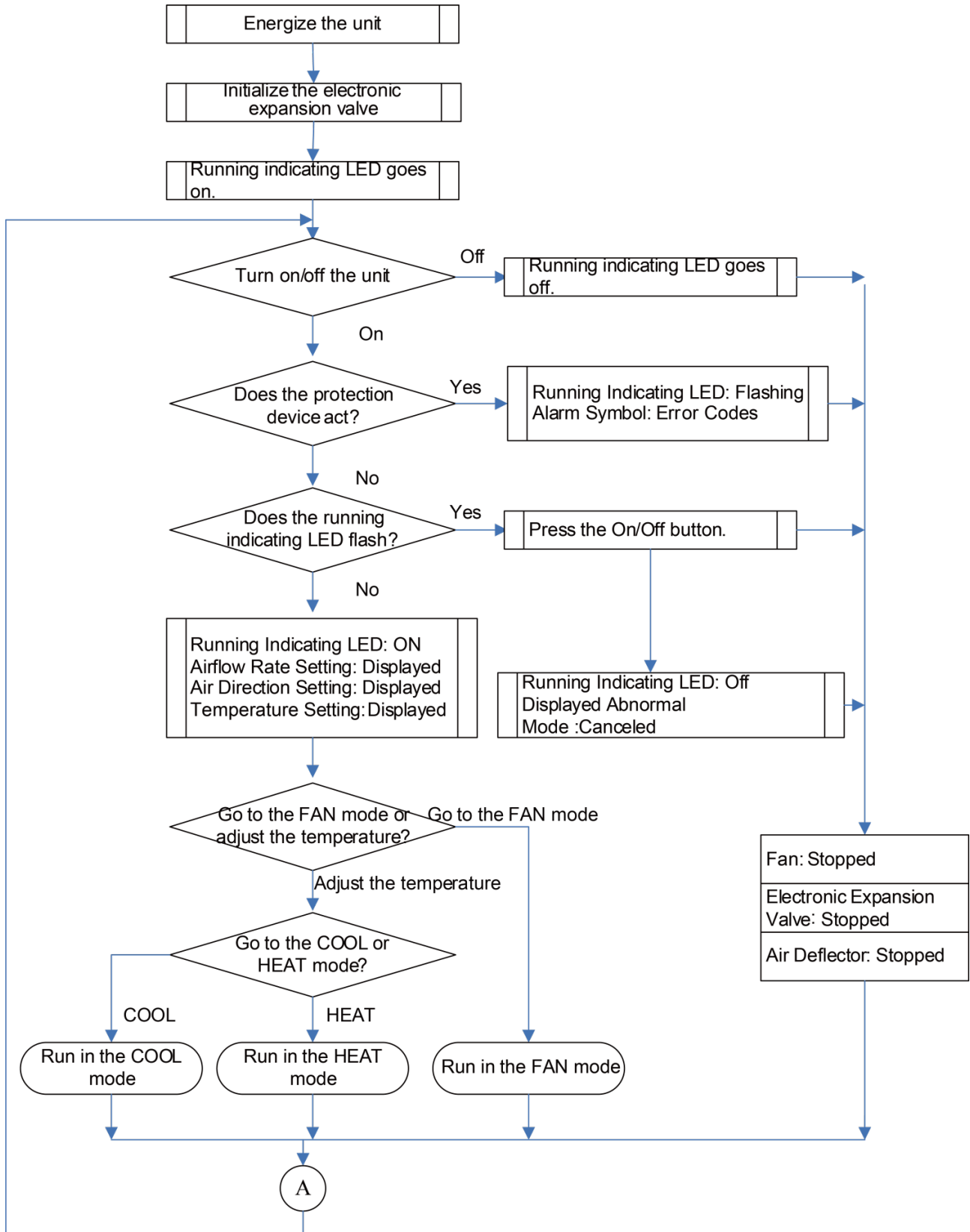

2 Wired Controller

2.1 Control Panel

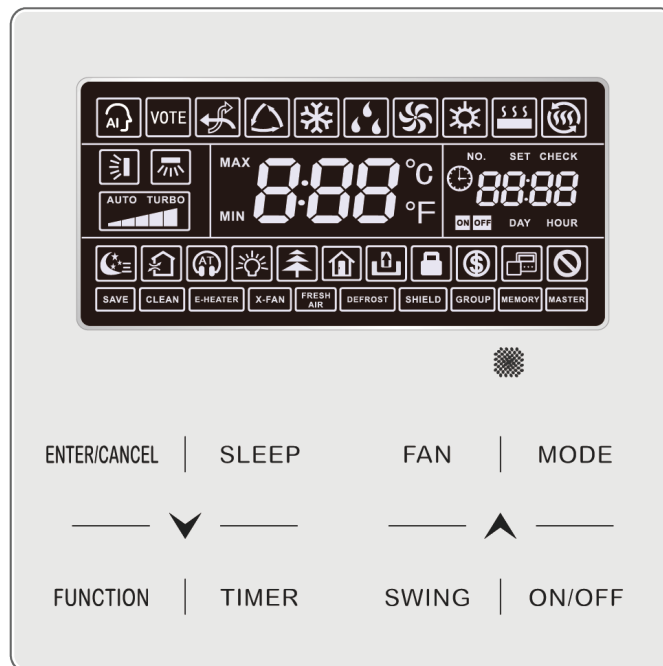

Fig.2.1 Appearance of wired controller

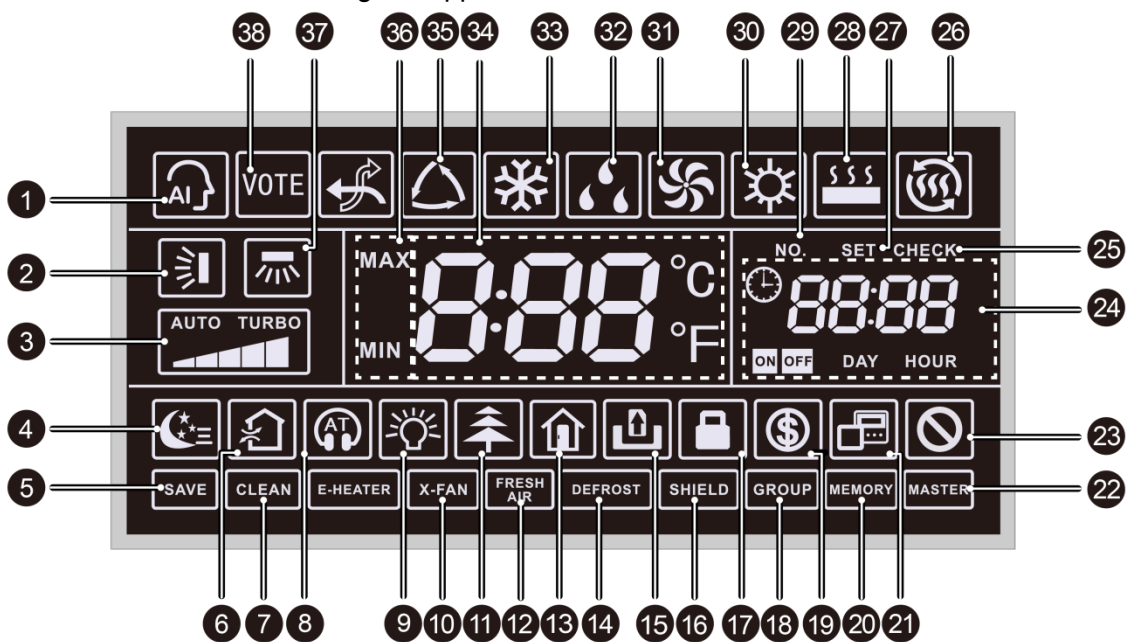







































Fig.2.2 LED graphics of wired controller

Table 2.1 LED display instruction

No.	Symbols	Instructions
1		As for the outdoor unit with AI function, once AI function is turned on, AI icon is displayed.
2		Up and down swing function.
3		Current set fan speed (including auto, low speed, medium-low speed, medium speed, medium-high speed, high speed and turbo seven status).
4		Sleep status.
5		Outdoor unit operates under Save mode/upper limit of system capacitor less 100%/remote Save status.
6		Air status, Indoor unit optional function.
7		Remind to clean the filter.
8		Quiet status (including Quiet and Auto Quiet two status).
9		Light On/Off function.
10		X-fan function.
11		Health function, Indoor unit optional function.
12		Fresh air control function of AHU-KIT.
13		Absence function.
14		Outdoor unit defrosting status.
15		Gate-control function.
16		Shielding status.
17		Child Lock status.
18		One wired controller controls multiple indoor units.
19		Save status of indoor unit.
20		Memory status (The indoor unit resumes the original setting state after power failure and then power recovery).
21		It indicates the current wired controller is the slave wired controller (address of wired controller is 02).
22		Current wired controller connects master indoor unit.
23		Invalid operation.
24		Timer zone: Display system clock and timer status.
25		Display "CHECK" icon under parameter view interface.
26		Space Heating mode.
27		Display "SET" icon under parameter setting interface.
28		Floor Heating mode (When Heating and Floor Heating simultaneously shows up, it indicates 3D Heating is activated).
29		When inquiring or setting project number of indoor unit, it displays "NO." icon.

No.	Symbols	Instructions
30		Heating mode.
31		Fan mode.
32		Dry mode.
33		Cooling mode.
34		It shows the setting temperature value(In case the wired controller is controlling a Fresh Air Indoor Unit, then the temperature zone will display FAP).
35		Auto mode (Under Auto mode, the indoor units will automatically select their operating mode as per the temperature change so as to make the ambient comfortable).
36		It's valid under Save mode and displays during setting process. Temperature lower limit for Cooling: Limit the minimum temperature value under Cooling or Dry mode. Temperature upper limit for Heating: Limit the maximum temperature value under Heating, Space Heating or 3D Heating mode.
37		Left and right swing function.
38		Indicates that the current system mode priority is voting mode.

NOTE: When wired controller is connected with different indoor units, some functions will be different.

Button Graphics

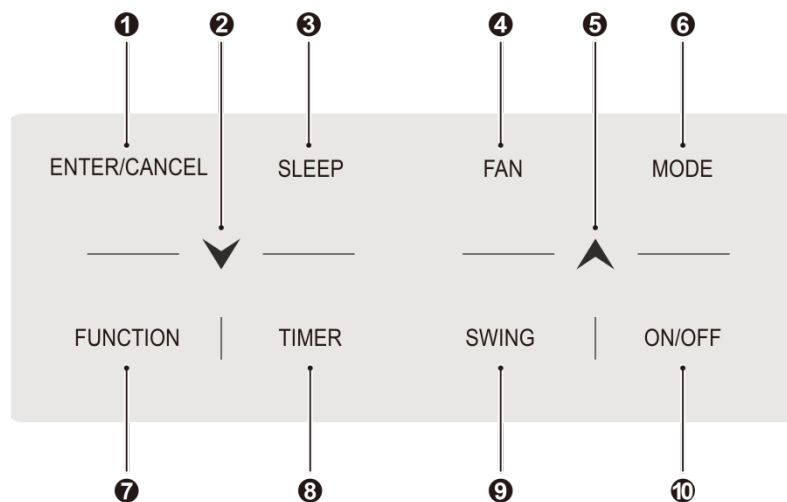

Fig.2.3 Button graphics

2.2 Installation and Removal

2.2.1 Installation dimensions

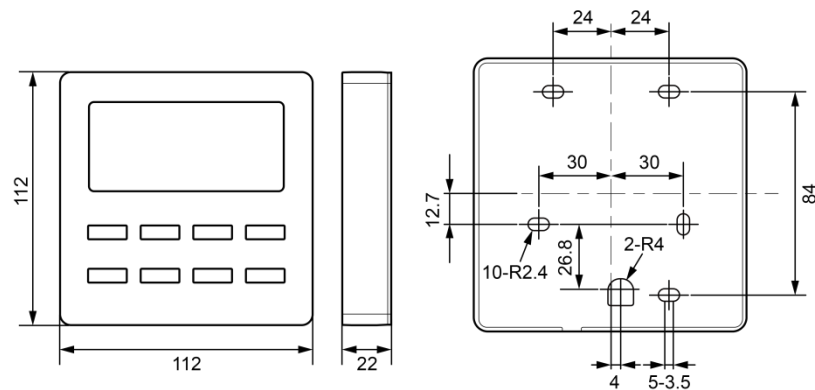

Fig.2.4 Installation dimensions

2.2.2 Installation method

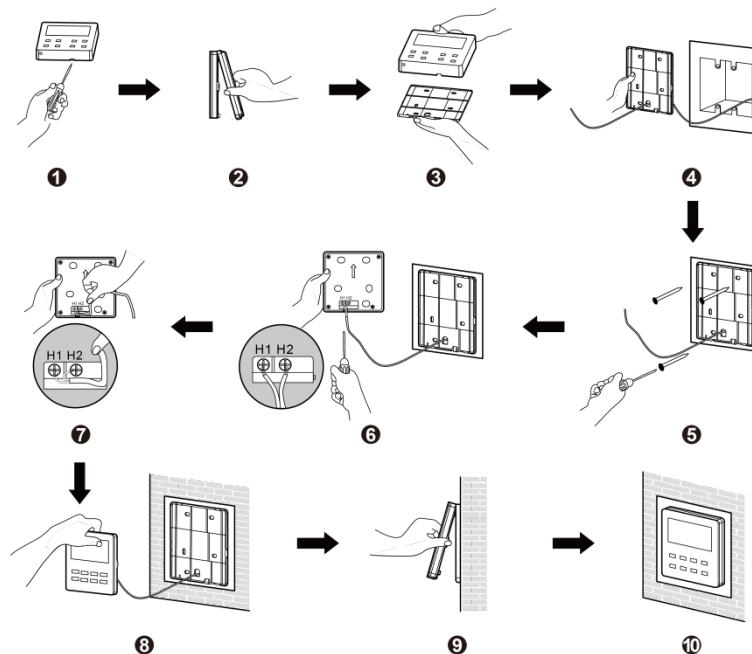

Fig.2.5 Installation of Wired Controller

Above is a simple installation method of wired controller. Please pay attention to the following:

- (1) Before installation, please cut off the power for indoor unit.
- (2) Pull out the two-core twisted pair from the installation hole on wall, and then pull this wire through the "U" shape hole at the rear side of Soleplate of wired controller.
- (3) Stick the bottom plate of wired controller on the wall and then use Self-tapping Screw ST3.9×25 MA or Screw M4×25 to fix Soleplate and installation hole on wall together.
- (4) Connect two-core twisted pair to H1 and H2 wiring column and then fix the screws.
- (5) Tidy up the lines in slot on the back of the panel, and then bundle the front panel of wired controller to its soleplate and the installation is completed.

NOTE: If the wire size of the selected communication line is too large, you can peel some sheath layer of communication wire to satisfy installation requirements.

2.2.3 Removal method

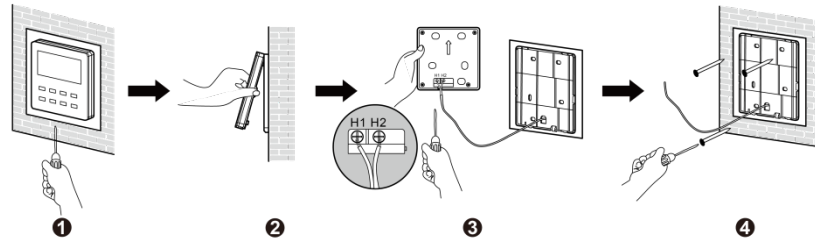

Fig.2.6 Removal of Wired Controller

2.2.4 Connection of communication cord

There are 4 ways to connect wired controller with indoor units' network:

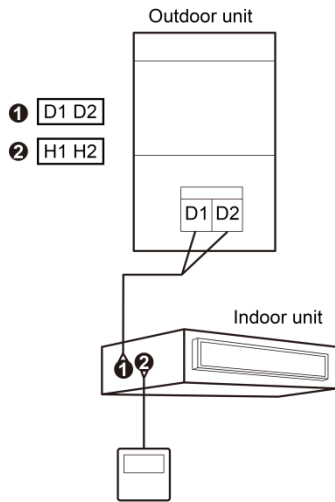

Fig.2.7 One wired controller controls one indoor unit

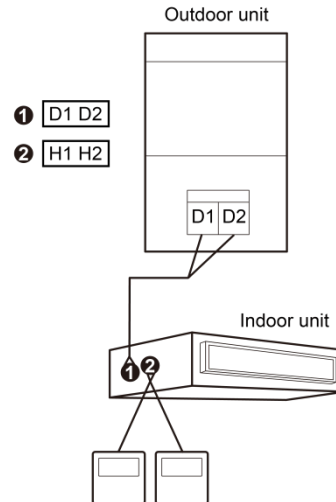

Fig.2.8 Two wired controllers control one indoor unit

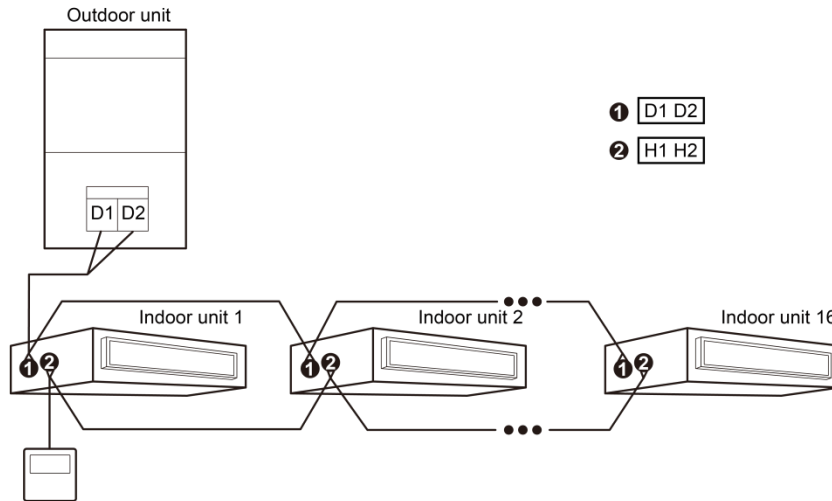

Fig.2.9 One wired controller controls multiple indoor units simultaneously

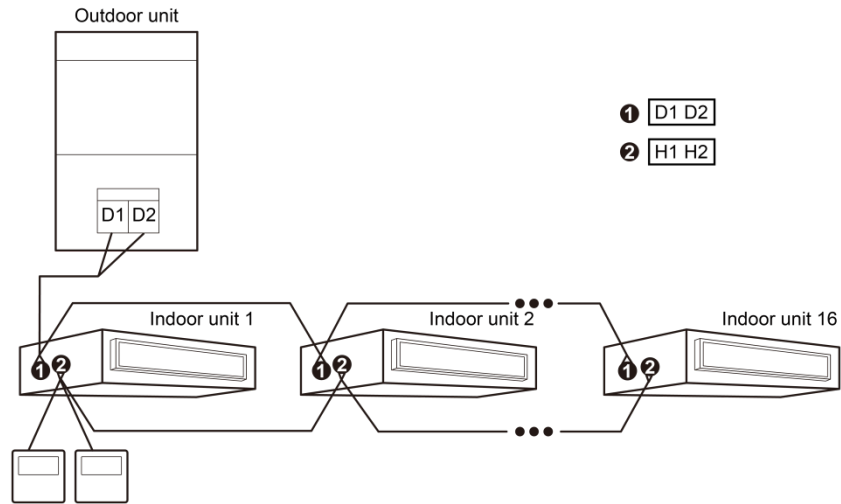

Fig.2.10 Two wired controllers control multiple indoor units simultaneously

Note:



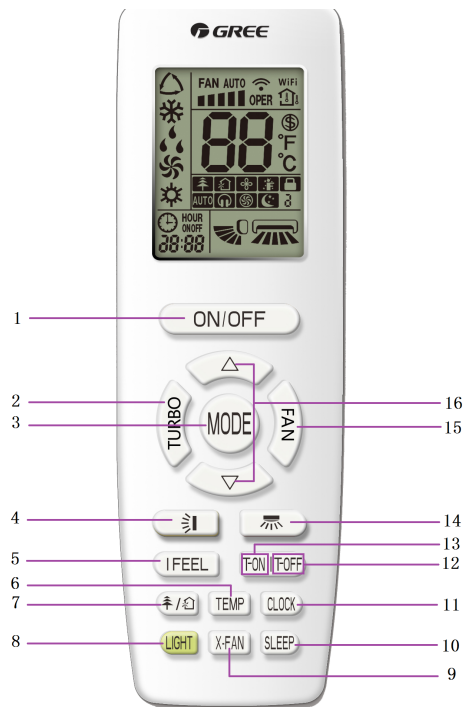

Floor standing indoor unit only applicable to Fig.2.7.

3 Remote Controller

3.1 Remote Controller YAP1F







Button name and function introduction

No.	Button name	Function
1	ON/OFF	Turn on or turn off the unit
2	TURBO	Set turbo function
3	MODE	Set operation mode
4		Set up&down swing status
5	I FEEL	Set I FEEL function
6	TEMP	Switch temperature displaying type on the unit's display
7		Set health function and air function
8	LIGHT	Set light function
9	X-FAN	Set X-FAN function
10	SLEEP	Set sleep function
11	CLOCK	Set clock of the system
12	TOFF	Set timer off function
13	TON	Set timer on function
14		Set left&right swing status
15	FAN	Set fan speed
16		Set temperature and time

3.2 Remote Controller YV1L1



No.	Button name	Function
1	ON/OFF	Turn on or turn off the unit
2	FAN	Set fan speed
3	▲/▼	Set temperature and time
4	MODE	Set operation mode
5		Set quiet function
6		Set health function and air function
7		Set left&right swing status
8		Set up&down swing status
9	X-FAN	Set X-FAN function
10	TIMER ON	Set timer on function
11	TIMER OFF	Set timer off function
12	SAVE	Set energy-saving function
13	SLEEP	Set sleep function
14	LIGHT	Set light function
15	CLOCK	Set clock of the system
16	I FEEL	Set I FEEL function
17	TEMP	Switch temperature displaying type on the unit's display

4 Panel Display

4.1 Control Panel

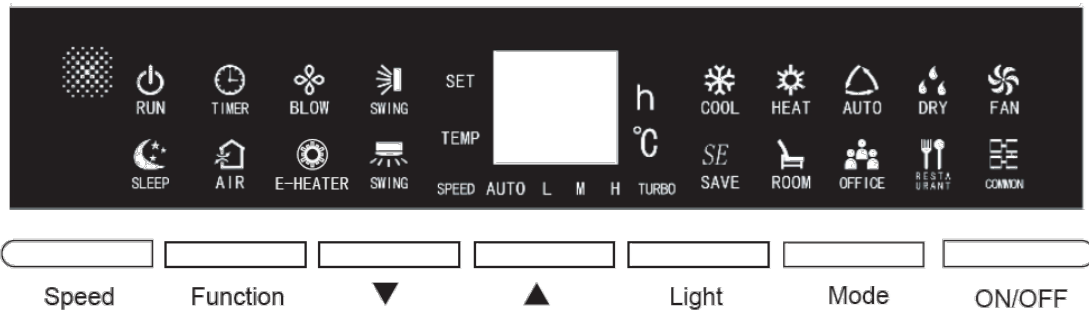

Notes:

“AIR” function is an optional function of indoor unit, for the unit without such function, this function is invalid; “E-HEATER”, “ROOM”, “OFFICE”, “RESTAURANT”, “COMMON” are obligate functions of indoor unit that cannot be set.

4.2 Operational Instruction

4.2.1 Start up and close down the unit

Press “ON/OFF” button to start up the unit. Press “ON/OFF” button to close down the unit.

4.2.2 Mode Setting

Under power-on status, each time press “Mode” button, the mode will be switched according to the following order circularly:

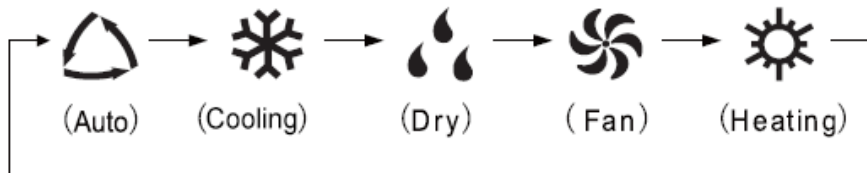

Notes:

- ① Only the master indoor unit can set auto mode;
- ② Under auto mode, if the indoor unit is in auto cooling, the “△” and “❄️” icons are on; if the indoor unit is in auto heating, the “☀️” and “🔥” icons are on.

4.2.3 Setting of Light ON/OFF Function

- (1) Light ON/OFF Function: can set the ON and OFF of light for display panel.
- (2) Under power-on or power-off status, press “Light” button to turn on and turn off the light of display panel.
- (3) When the light of display panel is turned off, press the other buttons other than “Light” button, the light on display panel will be turned off after 5 seconds.

4.2.4 Temperature Setting

Press “▼” or “▲” buttons under power-on status, the set temperature will be increased or decreased at 1°C each time; when long press the buttons, the temperature will be increased or decreased at 1°C every 0.3 seconds. The temperature setting range is: 16°C~30°C.



Note:

Under auto mode, the temperature cannot be set through pressing “▼” or “▲” buttons.



4.2.5 Function Setting

Press “Function” button under power-on or power-off status, it can enter into function setting status. Under function setting status, press “ON/OFF” button or without pressing any buttons for consecutive 5 seconds, it will quit the function setting status.

(1) Up and down swing function settings



Press “Function” button under power-on status to switch to up and down swing function, when “” icon flickers, press “▲” or “▼” button to start up or cancel the up and down swing function. If “” is on it means the function has been started up; if “” icon is off it means the function has been canceled.

(2) Left and right swing function settings

Press “Function” button under power-on status to switch to left and right swing function, when “” flickers, press “▲” or “▼” button to start up or cancel the left and right swing function. If “” icon is on it means the function has been started up; if “” icon is off it means the function has been canceled.



(3) Settings of X-fan



X-fan function: after closing down the unit under cooling and dry mode, the air conditioner will automatically dry the water of evaporator of indoor unit to prevent breeding of bacteria and mildew.

Turn on or cancel X-fan function: with the unit is started up, under cooling or dry mode, press “Function” button to switch to X-fan function, when “” flickers, press “▲” or “▼” buttons to start or cancel X-fan function. If “” icon is on it means the X-fan function has been started up, if “” icon is off it means the X-fan function has been canceled.

(4) Settings of Timer Function

Timer Function: under power-on status, the count down of power-off time can be set. Under power-off status, the count down of power-on time can be set.

Timer setting: press “function” button to switch to timer function, when “” icon flickers, press “▲” or “▼” button to adjust the setting time. After setting the time, press “ON/OFF” button or without pressing any buttons for consecutive 5 seconds, the setting time is confirmed and quit the function setting status. After quitting the function setting status, the “” icon is on, it means the timer function has been turned on.



Cancel timer: press “Function” button to switch to timer function, when “” icon flickers, press “▲” or “▼” button to set the time to be “00”, then the timer function is canceled; press “ON/OFF” button or without pressing any buttons for consecutive 5 seconds, it will quit the function setting status. After quitting the function setting status, the “” icon is off, it means the timer function has been canceled.



Count down setting range: 00~24 hours, in which “00” refers to closedown of timer function. Each time press “▲” or “▼” button, if it is within 10 hours, it will increase or decrease 0.5 hour each time, if

long press “▲” or “▼” button, it will increase or decrease 0.5 hour every 0.3 second; if it is over 10 hours, each time press “▲” or “▼” button will increase or decrease 1 hour each time, and if long press “▲” or “▼” button, it will increase or decrease 1 hour every 0.3 second.

(5) Setting of air renewal function

Air renewal function: through adjusting the fresh air volume to improve the air quality and keep the indoor fresh air.



Air renewal setting: press “Function” button to switch to air renewal function, when  icon flickers, press “▲” or “▼” button to adjust the air renewal level; after setting air renewal level, press “ON/OFF” button or without pressing any buttons for consecutive 5 seconds, the air renewal function has been confirmed to be turned on and then quit the function setting status. After quitting the function setting status, the  icon is on, it means the air renewal function has been turned on.

Cancel air renewal: press “Function” button to switch to air renewal function, when  icon flickers, press “▲” or “▼” button to set the air renewal as “00”, then the air renewal function is canceled; press “ON/OFF” button or without pressing any buttons for consecutive 5 seconds, it will quit the function setting status. After quitting function setting status, the  icon is off, it means the air renewal function is canceled.

Adjustment range of air renewal level: it can adjust the air renewal level to be 00~10, in which “00” refers to closing down air renewal function.

(6) Setting of Sleeping Function



Sleeping function: set the unit to enter into sleeping operational status, the unit will operate according to the preset sleeping temperature curve to create a comfortable sleeping environment and improve sleeping quality.

Turn on or cancel sleeping function: press “Function” button under power-on status to switch to sleeping function, when  icon flickers, press “▲” or “▼” button to turn on or cancel sleeping function. If  icon is on, it means the sleeping function is turned on; if  icon is off, it means the sleeping function is canceled.

There is no sleeping function under auto and swing mode.

(7) Setting of energy-saving function

Energy-saving function: through setting the lower temperature limit of cooling and dry mode and upper temperature limit of heating mode, to make the air conditioner operate in a smaller temperature range, thus save energy.

Turn on cooling energy-saving: with the unit is started up, under cooling or dry mode, press “Function” button to switch to energy-saving function, when  icon flickers, press “▲” or “▼” button to adjust cooling temperature limit, after setting cooling temperature limit, press “ON/OFF” button or without pressing any buttons for consecutive 5 seconds, the energy-saving function is confirmed to be turned on and quit the function setting status. After quitting function setting status, the  icon is on, it means the cooling energy-saving function has been turned on.

Turn on heating energy-saving: with the unit is started up, under heating mode, press “Function” button to switch to energy-saving function, press “▲” or “▼” button to adjust heating temperature limit, if the “SE SAVE” icon flickers, after setting heating temperature limit, press “ON/OFF” button or without pressing any buttons for consecutive 5 seconds, the energy-saving function is confirmed to be turned on and quit the function setting status. After quitting function setting status, the “SE SAVE” icon is on, it means the heating energy-saving function has been turned on.

Cancel energy-saving function: under energy-saving function setting status or under normal power-on status, press “Function” button and “▼” button simultaneously to cancel energy-saving function, when “SE SAVE” icon is off, it means the energy-saving function is canceled.

4.2.6 Speed Settings

Under power-on status, press “Speed” button, the speed will be circularly switched according to the following order:

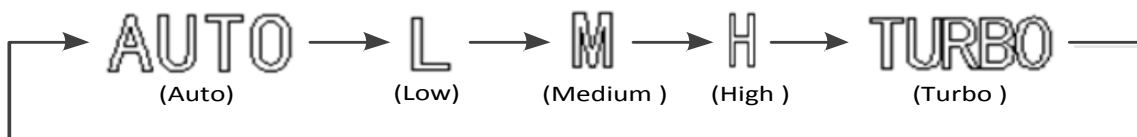

Notes:

- ① Under dry mode, the speed cannot be adjusted, it will be automatically set to be low.
- ② When the speed of indoor unit is adjusted to be auto speed, the indoor unit will automatically change speed according to the indoor ambient temperature, to make the indoor ambient temperature be more stable and comfortable.

4.2.7 Special Function

(1) Inquire address of indoor unit

Under power-off status, press “Speed” button and “ON/OFF” button simultaneously for 5 seconds, then the “88” LED will display the engineering No. of the indoor unit for 5 seconds; if the engineering No. is over two digits, it will circularly display the higher two digits and lower two digits.

(2) Inquire unit type

Under power-off status, simultaneously press “Mode” button and “ON/OFF” button for 5 seconds, then the “88” LED will display corresponding code for 5 seconds: heat pump unit will display “nA”, cooling only unit will display “nC”, heating only unit will display “nH”, swing type unit will display “nF”.

(3) Setting of power-fail memory function

Under power-off status, simultaneously press “Mode” button and “▲” button for 5 seconds to switch the memory method: if “88” LED displays “on”, it means it will memorize the on and off status of the unit after being de-energized (that is, after de-energizing and energizing the unit, the unit will resume to be the status before it is de-energized); if “88” LED displays “oF”, it means it will not memorized the on and off status of the unit after being de-energized (that is, after de-energizing and energizing the unit, the unit will still be power-off status).

(4) Setting of master indoor unit function

Under power-off status, long press “Mode” button for 5 seconds to set the indoor unit to be master

pattern indoor unit (master indoor unit), after finishing setting, the “88” LED will display “UC” for 5 seconds.

Notes:

When the master indoor unit is started up, the operational light “” on display panel will flicker for three times.

(5) Settings of Child Lock Function

Under power-on or power-off status, simultaneously press “▲” button and “▼” button for 5 seconds, it will turn on child lock function, the “88” LED will flicker and display “An” for three times; press “▲” button and “▼” button again for 5 seconds, it will cancel child lock function.

Under child lock status, the unit will not response if pressing other buttons, and the “88” LED will flicker and display “An” to remind the user that the unit is under child lock status.

(6) Long-distance Shielding Function

Long-distance shielding function: long-distance monitor or centralized controller can remotely control related functions of indoor unit or conduct shielding to make the operation invalid, thus realize long-distance control function.

Long-distance shielding function can be divided into full shielding and partial shielding. When it is in full shielding, all the remote control or operation by pressing buttons to the indoor unit will be invalid. If it is in partial shielding, the remote control or operation by pressing buttons to the shielded function of indoor unit will be invalid.

When long-distance monitor or centralized controller conduct long-distance shielding to indoor unit, if the user wants to remotely control or operate the unit by pressing buttons, the “88” LED will flicker and display “Ay” to remind the user that it is under long-distance shielding status.

5 Introduction to Unit Functions

Function Application of IDUs

Indoor unit functions cover user operation functions and engineering application functions. For user operation functions, refer to operating instructions of the IDU, wired controller, and remote controller.

Engineering application functions include:

SN	Function Name
1	Master IDU query and settings
2	Indoor unit project number query and settings
3	User parameter query
4	User parameter settings
5	Engineering parameter query
6	Engineering parameter settings

Engineering application functions can be operated through the IDU wired controller (XK46 or XK49 or XK79) or remote controller (YV1L1, fittings selectable).

5.1 Engineering Application Functions Operated through the XK46 Wired Controller

5.1.1 Master IDU Settings

The master IDU can be set through the wired controller or remote controller. The methods for setting the master IDU through the wired controller are as follows:

Method 1:

Step 1: Set an IDU to power-off status.

Step 2: Press and hold the “MODE” button on the wired controller for more than five seconds.

Step 3: Check whether the setting is successful. If it is, “MASTER” on the wired controller will be on.

Otherwise, repeat steps 1 and 2.



Method 2:

Step 1: Press and hold the “FUNCTION” button for five seconds in power-on or power-off status to enter the parameter query interface.

Step 2: Press and hold the “FUNCTION” button for five seconds in “C00” status to enter the parameter setting interface.

Step 3: Press “▲” or “▼” to switch level 2 parameter codes till “P10” is displayed on the temperature area.

Step 4: Press the “MODE” button to set the parameter to “01” and then Press the “ENTER” button. If the setting is successful, “MASTER” on the wired controller will be on.

Master IDU Display

- ① For IDUs connected with wired controllers, “MASTER” on the wired controller connected with the master IDU will be on.
- ② For IDUs embedded or connected with LED panels, the operation LED on the LED panel of the master IDU will blink three times.

Note:

After the master IDU is successfully set, stick the “” flag to the wired controller or unit panel for convenience of user operation and engineering maintenance. This flag is placed in the package bag of the ODU.

5.1.2 Project number Query and Settings

(1) Project number query of a single IDU

Press and hold the “FUNCTION” button for five seconds in power-on or power-off status to enter the parameter query interface “C00”. The timer area of the wired controller displays the project number of the current IDU. Synchronously, the double-eight digital LED of the IDU embedded or connected with an LED panel displays its own project number. If the current wired controller works in one-to-many mode, the timer area displays the IDU that has the minimum project number.

(2) Project number of multiple IDUs

Project number query of IDUs in one-to-many mode: Press and hold the “FUNCTION” button for five seconds in power-on or power-off status to enter the parameter query interface “C00”. Press “▽” to switch to “C01”. Press the “MODE” button to enter query. The timer area displays the project numbers of IDUs from small to large. Press “△” or “▽” to switch project numbers. Synchronously, the double-eight digital LED of the IDU embedded or connected with an LED panel displays its own project number.

Note:

It is normal if the buzzer of the IDU operated by the wired controller rings. The purpose of ringing the buzzer is to facilitate engineering commissioning personnel to locate the IDU, especially for the IDU without any LED panel because it cannot display its project number.

Project number query of IDUs in the entire communication network: Press and hold the “FUNCTION” button for five seconds in power-on or power-off status to enter the parameter query interface “C00”. Press “▽” to switch to “C18”. Press the “MODE” button to enter query. The timer area of each wired controller in the entire network displays the project number of the corresponding IDU. Synchronously, the double-eight digital LED of each IDU embedded or connected with an LED panel displays its own project number.

Method for quitting query:

- Quit the “C18” query interface.
- Press the “ON/OFF” button on any wired controller in the network.

(3) Project number settings of IDU

Press and hold the “FUNCTION” button for five seconds in power-on or power-off status to enter the parameter query interface “C00”. Continuously press the “MODE” button for three times, and then press and hold the “FUNCTION” button for five seconds to enter the engineering parameter setting interface. The temperature area displays “P00”. Press “▽” to switch to “P42”.

- Single IDU: Press the “MODE” button. The project number blinks in the timer area. Press “△” or “▽” to adjust the project number, and then Press the “ENTER” button to confirm and return to the upper-level menu.
- One-to-many: Press the “MODE” button to enter the IDU selection menu. Press “△” or “▽” to switch IDUs. Press the “MODE” button to set the project number of the current IDU in the same method as above.

5.1.3 User Parameter Query

User parameters can be queried in power-on or power-off status.

- (1) Press and hold the “FUNCTION” button for five seconds to enter the user parameter query interface. The temperature area displays “C00” and “View” is on.
- (2) Select a parameter code by pressing “▲” or “▼”.
- (3) Press the “ENTER/CANCEL” button to return to the upper-level menu till quitting parameter query.

The user parameter query list is as follows:

Table 2.1 User Parameter Query List

Parameter Code	Parameter Name	Parameter Range	View Method
C00	Parameter setting ingress	-	Display mode: Timer area: displays the project number of the current IDU. Note: If the current HBS network consists of multiple IDUs, only the IDU that has the minimum project number is displayed.
C01	Project number query of IDU and faulty IDU location	1-255: project number of online IDU	Operation method: In “C01” status, press the “MODE” button to enter project number query of IDU. Press “▲” or “▼” to switch the IDU SN. Display mode: Temperature area: displays the fault of the current IDU (in the case of multiple faults, they are circularly displayed every three seconds). Timer area: displays (project number conflict C5 fault)/project number of the current IDU (project numbers are arranged from small to large). Special operations: After users press the “MODE” button to enter project number query, the buzzer of the IDU operated by the wired controller will ring till users quit “C01” query or switch to the next IDU.
C03	Indoor unit quantity query in the system network	1-80	Timer area: displays the number of IDUs in the system network.

Parameter Code	Parameter Name	Parameter Range	View Method
C06	Preferential operation query	00: common operation 01: preferential operation	Operation method: In "C06" status, press the "MODE" button to enter the preferential operation query interface. Press "▲" or "▼" to switch the IDU SN. Display mode: Temperature area: displays the project number of the current IDU. Timer area: displays the preferential operation setting value of the current IDU.
C07	Indoor environment temperature query	-	Operation method: In "C07" status, press the "MODE" button to enter the indoor environment temperature query interface. Press "▲" or "▼" to switch the IDU SN. Display mode: Temperature area: displays the project number of the current IDU. Timer area: displays the temperature value of the indoor environment temperature sensor after replenishment.
C08	Prompt time query for air filter cleaning	4-416: days	Timer area: displays the prompt time for air filter cleaning.
C09	Wired controller address query	01, 02	Timer area: displays the address of the current wired controller.
C11	Indoor unit quantity query in one-to-many mode	1-16	Timer area: displays the number of IDUs controlled by the wired controller.
C12	Outdoor environment temperature query	-	Timer area: displays the temperature value of the environment temperature sensor of the master ODU.
C17	Indoor relative humidity query	20-90	Operation method: In "C17" status, press the "MODE" button to enter the indoor relative humidity query interface. Press "▲" or "▼" to switch the IDU SN. Display mode: Temperature area: displays the relative humidity value. Timer area: displays the project number of IDU (project numbers are arranged from small to large). If the HBS network consists of only one IDU, the timer area directly displays the IDU relative humidity value in the "C17" interface.

Parameter Code	Parameter Name	Parameter Range	View Method
C18	Indoor unit project number query in the communication network	1-255	<p>Operation method: In “C18” status, press the “MODE” button to enter the IDU project number query interface. Press “▲” or “▼” to switch the IDU SN.</p> <p>Cancellation method: 1) If users quit the “C18” query interface within 20 seconds, the project number display is cancelled. 2) If the query interface is quit after 20 seconds upon timeout, press the “ON/OFF” button in power-on or power-off status to cancel the project number display. 3) The method for cancelling the project number display on any wired controller in the network is the same as ②.</p> <p>Display mode: Temperature area: displays the SN of the current IDU (project numbers are arranged from small to large). Timer area: displays the project number of the current IDU. Each IDU/wired controller in the network displays its own project number (the wired controller circularly displays project numbers of IDUs every second from small to large).</p>
C20	Fresh-air IDU outlet temperature query	-9 to 99	<p>Operation method: In “C20” status, press the “MODE” button to enter the fresh-air IDU temperature query interface. Press “▲” or “▼” to switch the IDU SN.</p> <p>Display mode: Temperature area: displays the project number of the current IDU (1-16, project numbers are arranged from small to large). Timer area: displays the fresh-air IDU outlet temperature. If the HBS network consists of only one IDU, the timer area directly displays the fresh-air IDU outlet temperature in the “C20” interface.</p>
C23	Inquiry of the version of wired controller	-	<p>Display mode: Display in timer zone: version of the wired controller (display on the right)</p> <p>Note: ①. Version of the wired controller refers to the version of the program of the wired controller. ③ .The version number doesn't have decimal points. It's an integral number.</p>

Note:

In parameter query status, “FAN”, “TIMER”, “SLEEP”, and “SWING” are invalid. By pressing the “ON/OFF” button, users can return to the main interface but not power on/off the unit.

In parameter query status, signals of the remote controller are invalid.

5.1.4 User Parameter Settings

User parameters can be set in power-on or power-off status.

- (1) Press and hold the “FUNCTION” button for five seconds. The temperature area displays “C00”. Press and hold the “FUNCTION” button for another five seconds to enter the wired controller parameter setting interface. The temperature area displays “P00”.
- (2) Select a parameter code by pressing “▲” or “▼”. Press the “MODE” button to switch to parameter value settings. The parameter value blinks. Adjust the parameter value by pressing “▲” or “▼” and then press the “ENTER/CANCEL” button to complete settings.

- (3) Press the “ENTER/CANCEL” button to return to the upper-level menu till quitting parameter settings.
- (4) The user parameter setting list is as follows:

Table 2.2 User Parameter Setting List

Parameter Code	Parameter Name	Parameter Range	Default Value	Remark
P10	Master IDU settings	00: Not change the master/slave status of the current IDU 01: set the current IDU to master IDU	00	After the IDU connected with the current wired controller is successfully set to master IDU, “MASTER” on the wired controller is on.
P11	Infrared connection settings of wired controller	00: disabled 01: enabled	01	This setting can only be enabled through the master wired controller. When the infrared remote receiving function of the wired controller is disabled, neither the master nor slave wired controller can receive remote signals. The wired controllers can only be operated by pressing.
P13	Wired controller address settings	01: master wired controller 02: slave wired controller	01	When two wired controllers simultaneously control one or more IDUs, the two wired controllers should use different addresses. The slave wired controller (address: 02) does not have the unit parameter setting function except its own address settings.
P14	Group-controlled IDU quantity settings	00: disabled 01-16: number of indoor units	01	This value is set based on the number of connected IDUs. If the current value is inconsistent with the actual number of group-controlled IDUs, “L9” fault may occur.
P16	Unit setting for display temperature	00: °C 01: °F	00	
P30	Static pressure setting for general indoor unit	Type 1: 03.04.05.06.07 Type 2: 01.02.03.04.05.06.07.08 .09	05	01-09 are valid for high ESP duct type unit; only 03-07 are valid for other indoor unit.
P31	Ceiling installation height setting	00: standard-ceiling installation height 01: high-ceiling installation height	00	-
P33	Timer function settings	00: common timer 01: time-point timer	00	-
P34	Repeating validity for time-point timer	00: single timer 01: repeated everyday	01	This setting is valid only when the timer function is set to time-point timer.
P37	Upper temperature limit setting for auto mode	17°C -30°C (63°F~86°F)	25 (77°F)	When temperature unit is °C : upper temperature limit-lower temperature limit ≥1; When temperature unit is °F : upper temperature limit-lower temperature limit ≥2;
P38	Lower temperature limit setting for auto mode	16°C -29°C (61°F~84°F)	20 (68°F)	
P43	Preferential operation settings	00: common operation 01: preferential operation	00	When power supply is insufficient, users are allowed to power on/off the IDU set with preferential operation and other IDUs are forcibly powered off. A fault code is displayed on the IDU that is forcibly powered off.
P46	Accumulated time clearing for air filter cleaning	00: not cleared 01: cleared	00	-
P49	Opening angle of indoor unit air-return plate*	01: angle 1(25°) 02: angle 2(30°) 03: angle 3(35°)	01	Only applicable to units with air-return plate.
P50	Air outlet temperature setting of cooling for Fresh Air Unit	16°C~30°C (61~86°F)	18°C (64°F)	Only applicable to Fresh Air Indoor Unit.

Parameter Code	Parameter Name	Parameter Range	Default Value	Remark
P51	Air outlet temperature setting of heating for Fresh Air Indoor Unit	16°C~30°C (61~86°F)	22°C (72°F)	Only applicable to Fresh Air Indoor Unit.
P54	Linkage function setting of Fresh Air Indoor Unit	00: without linkage control 01: with linkage control	00	After linkage function is set, Fresh Air Indoor Unit will be turned on/off following the on/off status of common indoor unit. Besides, Fresh Air Indoor Unit can also be turned on/off manually. NOTICE: Only applicable to Fresh Air Indoor Unit.
P69	Signal type of gate control	01: 5-12V DC (including 12V) signal of gate control 02: 12V-24V DC (excluding 12V) signal of gate control 03: 110V AC signal of gate control 04: 220V AC signal of gate control	04	Only applicable to wired controller XK79 with gate control.
P71	Setback function setting	00: invalid 01: valid	00	Only applicable for gate control wired controller.
P72	Upper temperature limit of Setback function	20~30°C (68~86°F)	26°C (79°F)	Only applicable for gate control wired controller.
P73	Lower temperature limit of Setback function	16~26°C (61~79°F)	20°C (68°F)	Only applicable for gate control wired controller.
P74	Gate control status setting	00: OFF 01: Operate at the status before pulling out the status	01	
P78	Cold air prevention time setting for indoor unit	00: 180s 01: 300s 02: 420s 03: 600s	00	
P82	Time format setting	00: 24h format 01: 12h format	00	
P63, P64, P65, P76 and P77 are reserved code. Please do not set it.				

Note:

In parameter setting status, “FAN”, “TIMER”, “SLEEP”, and “SWING” are invalid. By pressing the “ON/OFF” button, users can return to the main interface but not power on/off the unit.

In parameter setting status, signals of the remote controller are invalid.

5.1.5 Engineering Parameter Query

Engineering parameters can be queried in power-on or power-off status.

Press and hold the “FUNCTION” button for five seconds to enter the engineering parameter query interface. The temperature area displays “C00” and “View” is on.

- (1) Within five seconds after “C00” is displayed, continuously press the “MODE” button for three times in an interval less than one second to enter engineering parameter query.
- (2) Select a parameter code by pressing “▲” or “▼”.
- (3) Press the “ENTER/CANCEL” button to return to the upper-level menu till quitting parameter

query.

In the engineering parameter query interface, users can also query user parameters listed in Table 3.1.

The engineering parameter query list is as follows:

Table 2.3 Engineering Parameter Query List

Parameter Code	Parameter Name	Parameter Range	View Method
C00	Parameter setting ingress (default)	-	Display mode: Timer area: displays the project number of the current IDU. Note: If the current HBS network consists of multiple IDUs, only the IDU that has the minimum project number is displayed.
C02	Indoor unit capacity query	-	Operation method: In "C02" status, press the "MODE" button to enter the preferential operation query interface. Press "▲" or "▼" to switch the project number of IDU. Display mode: Temperature area: displays the project number of the current IDU. Timer area: displays the current IDU capacity/IDU capacity after adjustment.
C04	Project number query of master IDU	1-255: project number 00: no master IDU	Timer area: displays the project number of the master IDU/00.
C05	Historical fault query ingress of IDU	Five historical faults	Operation method: 1. In "C05" status, press the "MODE" button to enter the historical fault query interface. Press "▲" or "▼" to switch the project number of IDU. Press the "MODE" button to enter fault code query of the current IDU. Press "▲" or "▼" to switch the fault SN. Press the "ENTER/CANCEL" button to return to the upper-level menu. Display mode: Temperature area: displays the fault SN and fault code. Timer area: displays the project number of IDU.
C10	Static pressure setting query of ODU	00: 0 Pa 20: 20 Pa 50: 50 Pa 82: 82 Pa	Operation method: In "C10" status, press the "MODE" button to enter static pressure setting query of ODU. Press "▲" or "▼" to switch the ODU address. Display mode: Temperature area: displays the address of the current ODU. Timer area: displays the static pressure setting value.
C13	Outdoor unit network number query	1-255	Timer area: displays the network number of the current ODU.

Parameter Code	Parameter Name	Parameter Range	View Method
C14	Temperature query for inlet-tube temperature sensor of IDU	-9 to 99	<p>Operation method: In "C14" status, press the "MODE" button to enter inlet-tube temperature sensor query of IDU. Press "▲" or "▼" to switch the IDU SN.</p> <p>Display mode: Temperature area: displays the project number of the current IDU. Timer area: displays the temperature value. If the HBS network consists of only one IDU, the timer area directly displays the temperature value in the "C14" interface. No matter Fahrenheit or Centigrade remote signals are received, the temperature is displayed in Centigrade. When the wired controller displays the inlet-tube temperature after receiving signals from the remote controller, the inlet-tube temperature of the IDU that has the minimum project number in the HBS network is displayed by default.</p>
C15	Temperature query for outlet temperature sensor of IDU	-9 to 99	<p>Operation method: In "C15" status, press the "MODE" button to enter outlet temperature sensor query of IDU. Press "▲" or "▼" to switch the IDU SN.</p> <p>Display mode: Temperature area: displays the project number of the current IDU. Timer area: displays the temperature value. If the HBS network consists of only one IDU, the timer area directly displays the temperature value in the "C14" interface. No matter Fahrenheit or Centigrade remote signals are received, the temperature is displayed in Centigrade. When the wired controller displays the inlet-tube temperature after receiving signals from the remote controller, the inlet-tube temperature of the IDU that has the minimum project number in the HBS network is displayed by default.</p>
C16	Opening degrees query of electronic expansion valve of IDU	0-20	<p>Operation method: In "C16" status, press the "MODE" button to enter electronic expansion valve opening degree query of IDU. Press "▲" or "▼" to switch the IDU SN.</p> <p>Display mode: Temperature area: displays the project number of the current IDU. Timer area: displays the opening degree value. If the HBS network consists of only one IDU, the timer area directly displays the opening degree value of electronic expansion valve in the "C16" interface. When the wired controller displays the opening degree of electronic expansion valve after receiving signals from the remote controller, the opening degree of electronic expansion valve of the IDU that has the minimum project number in the HBS network is displayed by default.</p>
n2	Capacity configuration ratio upper-limit of outdoor/IDU	35: 135% 50: 150%	<p>Temperature area: displays the parameter code. Timer area: displays the setting value of capacity configuration ratio of the current outdoor/IDU.</p>

Parameter Code	Parameter Name	Parameter Range	View Method																																																																					
n6	Historical fault query ingress of ODU	Five historical faults	<p>Operation method: In “n6” status, press the “MODE” button to enter fault code query of ODU (when a wired controller controls multiple IDUs, only the faults memorized by the IDU that has the minimum project number can be queried). Press “▲” or “▼” to switch the fault SN. Press the “ENTER/CANCEL” button to return to the upper-level menu.</p> <p>Display mode: Temperature area: displays the fault SN and fault code from left to right (1-5, faults are arranged from the earliest to the latest). Timer area: displays the project number of the ODU.</p>																																																																					
n7	Parameter query ingress of ODU	01-13 25-29	<p>Operation method (n7 query is not supported for the slave wired controller): In “n7” status, the timer area is not displayed. Press the “MODE” button to enter parameter query of ODU. The first bit in the temperature area (display bit of the ODU module ID) blinks. Press “▲” or “▼” to switch the ODU module ID. Press the “MODE” button to select an ODU module. In this case, the first bit in the temperature area stops blinking, and the second and third bits in the temperature area display the parameter code. The timer area displays a corresponding parameter value. Press “▲” or “▼” to switch the parameter code and press the “ENTER/CANCEL” button to return to the upper-level menu.</p> <p>Display mode: Temperature area: displays the ODU module ID and parameter code from left to right. Timer area: displays a corresponding parameter value to the right.</p> <table border="1"> <thead> <tr> <th>Parameter Code</th> <th>Parameter Name</th> <th>Unit</th> </tr> </thead> <tbody> <tr><td>01</td><td>Outdoor environment temperature</td><td>°C</td></tr> <tr><td>02</td><td>Operation frequency of compressor 1</td><td>Hz</td></tr> <tr><td>03</td><td>Operation frequency of compressor 2</td><td>Hz</td></tr> <tr><td>04</td><td>Operation frequency of outdoor fan</td><td>Hz</td></tr> <tr><td>05</td><td>Module high-pressure</td><td>°C</td></tr> <tr><td>06</td><td>Module low-pressure</td><td>°C</td></tr> <tr><td>07</td><td>Discharge temperature of compressor 1</td><td>°C</td></tr> <tr><td>08</td><td>Discharge temperature of compressor 2</td><td>°C</td></tr> <tr><td>09</td><td>Discharge temperature of compressor 3</td><td>°C</td></tr> <tr><td>10</td><td>Discharge temperature of compressor 4</td><td>°C</td></tr> <tr><td>11</td><td>Discharge temperature of compressor 5</td><td>°C</td></tr> <tr><td>12</td><td>Discharge temperature of compressor 6</td><td>°C</td></tr> <tr><td>13</td><td>Operation frequency of compressor 3</td><td>Hz</td></tr> <tr><td>25</td><td>Outdoor unit heating EXV1 (Actual value = Displayed value * 10)</td><td>PLS</td></tr> <tr><td>26</td><td>Outdoor unit heating EXV2 (Actual value = Displayed value * 10)</td><td>PLS</td></tr> <tr><td>27</td><td>Subcooler EXV (Actual value = Displayed value * 10)</td><td>PLS</td></tr> <tr><td>28</td><td>Defrosting temperature</td><td>°C</td></tr> <tr><td>29</td><td>Liquid-extracting temperature of subcooler</td><td>°C</td></tr> <tr><td>30</td><td>Outlet temperature of accumulator</td><td>°C</td></tr> <tr><td>31</td><td>Oil return temperature</td><td>°C</td></tr> <tr><td>32</td><td>Inlet-tube temperature of condenser</td><td>°C</td></tr> <tr><td>33</td><td>Outlet temperature of condenser</td><td>°C</td></tr> </tbody> </table>	Parameter Code	Parameter Name	Unit	01	Outdoor environment temperature	°C	02	Operation frequency of compressor 1	Hz	03	Operation frequency of compressor 2	Hz	04	Operation frequency of outdoor fan	Hz	05	Module high-pressure	°C	06	Module low-pressure	°C	07	Discharge temperature of compressor 1	°C	08	Discharge temperature of compressor 2	°C	09	Discharge temperature of compressor 3	°C	10	Discharge temperature of compressor 4	°C	11	Discharge temperature of compressor 5	°C	12	Discharge temperature of compressor 6	°C	13	Operation frequency of compressor 3	Hz	25	Outdoor unit heating EXV1 (Actual value = Displayed value * 10)	PLS	26	Outdoor unit heating EXV2 (Actual value = Displayed value * 10)	PLS	27	Subcooler EXV (Actual value = Displayed value * 10)	PLS	28	Defrosting temperature	°C	29	Liquid-extracting temperature of subcooler	°C	30	Outlet temperature of accumulator	°C	31	Oil return temperature	°C	32	Inlet-tube temperature of condenser	°C	33	Outlet temperature of condenser	°C
Parameter Code	Parameter Name	Unit																																																																						
01	Outdoor environment temperature	°C																																																																						
02	Operation frequency of compressor 1	Hz																																																																						
03	Operation frequency of compressor 2	Hz																																																																						
04	Operation frequency of outdoor fan	Hz																																																																						
05	Module high-pressure	°C																																																																						
06	Module low-pressure	°C																																																																						
07	Discharge temperature of compressor 1	°C																																																																						
08	Discharge temperature of compressor 2	°C																																																																						
09	Discharge temperature of compressor 3	°C																																																																						
10	Discharge temperature of compressor 4	°C																																																																						
11	Discharge temperature of compressor 5	°C																																																																						
12	Discharge temperature of compressor 6	°C																																																																						
13	Operation frequency of compressor 3	Hz																																																																						
25	Outdoor unit heating EXV1 (Actual value = Displayed value * 10)	PLS																																																																						
26	Outdoor unit heating EXV2 (Actual value = Displayed value * 10)	PLS																																																																						
27	Subcooler EXV (Actual value = Displayed value * 10)	PLS																																																																						
28	Defrosting temperature	°C																																																																						
29	Liquid-extracting temperature of subcooler	°C																																																																						
30	Outlet temperature of accumulator	°C																																																																						
31	Oil return temperature	°C																																																																						
32	Inlet-tube temperature of condenser	°C																																																																						
33	Outlet temperature of condenser	°C																																																																						
A6	Unit cooling/heating function	nA:cooling/heating nC:single-cooling nH:single-heating nF: air supply	<p>Temperature area: displays the parameter code. Timer area: displays the cooling/heating function setting value of the current unit.</p>																																																																					

Parameter Code	Parameter Name	Parameter Range	View Method																										
nb	Bar code query of IDU	0-9, A-Z, a-z, -	<p>Operation method (nb query is not supported for the slave wired controller):</p> <p>In “nb” status, the timer area is not displayed. Press the “MODE” button to enter bar code query. The temperature area displays “nb” and the project number in the timer area blinks. Press “▲” or “▼” to switch the project number of IDU.</p> <p>Press the “MODE” button to select an IDU. The temperature area displays “Un” and the timer area displays “-n”. Press “▲” or “▼” to display the entire-unit bar code and controller bar code of IDU. Press the “ENTER/CANCEL” button to return to the upper-level menu. The temperature area displays “nb” and the timer area displays the project number of the queried IDU. Press the “ENTER/CANCEL” button again to return to the upper-level menu.</p> <p>Display mode:</p> <p>Temperature area: displays nb/Un/Pc/bar code.</p> <p>Timer area: displays -n/project number/bar code.</p> <p>The following is an example:</p> <table border="1"> <thead> <tr> <th>Example</th> <th>Temperature Area</th> <th>Timer Area</th> <th>Remark 1</th> <th>Remark 2</th> </tr> </thead> <tbody> <tr> <td rowspan="3">Entire-unit bar code of IDU N1r0128150066</td> <td>Un (to the right)</td> <td>-n (in the middle)</td> <td>It indicates that the following is the entire-unit bar code of IDU.</td> <td rowspan="6">Press “▼” to display downward and press “▲” to display upward.</td> </tr> <tr> <td>N1r</td> <td>0128</td> <td>It indicates the former seven bits of the bar code.</td> </tr> <tr> <td>150</td> <td>066</td> <td>It indicates the latter six bits of the bar code.</td> </tr> <tr> <td rowspan="3">Controller bar code of IDU N1r0128150067</td> <td>Pc</td> <td>-n</td> <td>It indicates that the following is the controller bar code of IDU.</td> </tr> <tr> <td>N1r</td> <td>0128</td> <td>It indicates the former seven bits of the bar code.</td> </tr> <tr> <td>150</td> <td>067</td> <td>It indicates the latter six bits of the bar code.</td> </tr> </tbody> </table> <p>Note:</p> <ol style="list-style-type: none"> ①. Un indicates the entire-unit bar code of IDU and Pc indicates the controller bar code of IDU. ②. When there is only one IDU, press the “MODE” button in “nb” status to enter bar code query without selecting the project number of IDU. ③. The system quits the query status if no operations are performed in 60 seconds. ④. The bar code query starts from the entire-unit bar code of IDU and ends at the controller bar code of IDU without circulation. That is, the query does not start again even if users press “▼”. 	Example	Temperature Area	Timer Area	Remark 1	Remark 2	Entire-unit bar code of IDU N1r0128150066	Un (to the right)	-n (in the middle)	It indicates that the following is the entire-unit bar code of IDU.	Press “▼” to display downward and press “▲” to display upward.	N1r	0128	It indicates the former seven bits of the bar code.	150	066	It indicates the latter six bits of the bar code.	Controller bar code of IDU N1r0128150067	Pc	-n	It indicates that the following is the controller bar code of IDU.	N1r	0128	It indicates the former seven bits of the bar code.	150	067	It indicates the latter six bits of the bar code.
Example	Temperature Area	Timer Area	Remark 1	Remark 2																									
Entire-unit bar code of IDU N1r0128150066	Un (to the right)	-n (in the middle)	It indicates that the following is the entire-unit bar code of IDU.	Press “▼” to display downward and press “▲” to display upward.																									
	N1r	0128	It indicates the former seven bits of the bar code.																										
	150	066	It indicates the latter six bits of the bar code.																										
Controller bar code of IDU N1r0128150067	Pc	-n	It indicates that the following is the controller bar code of IDU.																										
	N1r	0128	It indicates the former seven bits of the bar code.																										
	150	067	It indicates the latter six bits of the bar code.																										

Note:

In parameter query status, “FAN”, “TIMER”, “SLEEP”, and “SWING” are invalid. By pressing the “ON/OFF” button, users can return to the main interface but not power on/off the unit.

In parameter query status, signals of the remote controller are invalid.

5.1.6 Engineering Parameter Settings

Engineering parameters can be set in power-on or power-off status.

- (1) Press and hold the “FUNCTION” button for five seconds. The temperature area displays “C00”. Continuously press the “MODE” button for three times, and then press and hold the “FUNCTION” button for five seconds to enter the engineering parameter setting interface. The temperature area displays “P00”.
- (2) Select a parameter code by pressing “▲” or “▼”. Press the “MODE” button to switch to parameter value settings. The parameter value blinks. Adjust the parameter value by pressing “▲” or “▼” and then press the “ENTER/CANCEL” button to complete settings.
- (3) Press the “ENTER/CANCEL” button to return to the upper-level menu till quitting parameter settings.

In the engineering parameter setting interface, users can also set user parameters listed in Table 3.2.

The engineering parameter setting list is as follows:

Table 2.4 Engineering Parameter Setting List

Parameter Code	Parameter Name	Parameter Range	Default Value	Remark
P15	Power-down memory mode	00: standby after power-down recovery 01: restoring the original status after power-down recovery	00	-
P17	Historical fault clearing for IDU	00: not cleared 01: cleared	00	Historical faults of all IDUs controlled by the current wired controller are cleared.
P20	Environment temperature sensor settings for IDU	01: temperature sensor of air return vent 02: temperature sensor of wired controller 03: temperature sensor of air return vent for cooling, dehumidifying, and air supply; temperature sensor of wired controller for heating 04: temperature sensor of wired controller for cooling, dehumidifying, and air supply; temperature sensor of air return vent for heating	03	When there are master and slave wired controllers and the temperature sensor of wired controller is used, only the temperature sensor of the master wired controller is used by default. Note: ① In automatic mode, the environment temperature sensor settings are invalid for a common IDU but the setting value is memorized. ② The environment temperature sensor settings are invalid for a fresh-air IDU. The temperature sensor of air return vent is used by default.
P21	Corrected value of environment temperature sensor of IDU (for cooling, dehumidifying, and air supply)	-15 to +15	Temperature sensor of unit: 0°C; temperature sensor of wired controller: 0°C	Press “▲” or “▼” to add or reduce by 1°C.
P22	Corrected value of environment temperature sensor of IDU (for heating, fast heating, and air warming)	-15 to +15	Temperature sensor of unit: -2°C; temperature sensor of wired controller: 0°C	Press “▲” or “▼” to add or reduce by 1°C. The temperature sensor of unit and the temperature sensor of wired controller share the same corrected value. In heating mode, corrected value of temperature sensor of unit = corrected value of temperature sensor of wired controller - 2°C.

Parameter Code	Parameter Name	Parameter Range	Default Value	Remark
P32	Capacity adjustment function of IDU	-40% to +40%	00	Press “▲” or “▼” to add or reduce by 10%.
P35	Factory setting recovery for user functions	00: invalid 01: valid	00	Select “01” and then press and hold the “ENTER/CANCEL” button to restore the factory settings for user functions (factory setting recovery fails if remote shielding is valid).
P36	Factory setting recovery for engineering settings	00: invalid 01: valid	00	Select “01” and then press and hold the “ENTER/CANCEL” button to restore the factory status for engineering settings (factory setting recovery fails if remote shielding is valid).
P40	Prevention for heat collection	00: disabled 10: 10s 20: 20s 30: 30s 40: 40s 50: 50s 60: 60s	00	It indicates the number of seconds for enabling the low-level fan every 15min.
P41	Longest defrosting time setting for outdoor unit	10/15/20: 10/15/20min	15	
P42	Project number settings of IDU	1-255	Automatically generated upon the initial system operation	In “P42” status, press the “MODE” button to enter the setting menu. The project number blinks in the timer area. Press “▲” or “▼” to adjust the project number. Press the “ENTER/CANCEL” button to confirm settings and return to the upper-level menu.
P45	One-key project number reset for IDU	00: invalid 01: valid	00	When it is set to “01”, the wired controller initiates an IDU project number reset command.
P48	Minimum opening degree setting for heating breakdown of IDU expansion valves	00: automatically controlled 1-500	-	After the default minimum opening degree for heating breakdown is manually modified, the opening degree remains unchanged upon heating breakdown.
P53	AHU-KIT linkage function setting	00: invalid 01: valid	00	When setting “01”, multiple AHU-KIT can operate simultaneously.
P55	Static pressure settings for DC Fresh Air Indoor Unit	Setting range: 01、02、03、04、05、06、07、08、09、10、11、12、13	08	Only applicable to DC Fresh Air Indoor Unit.
P56	Fan status setting under heating mode	00: OFF; 01: fan speed setting;	00	It's the fan status when heating to the temperature point. When setting “01”, the fan operates according to the set fan speed. Only applicable for AHU-KIT indoor unit.
P60	AHU-KIT working method setting	00: air-return type 01: fresh air type		Only applicable for AHU-KIT indoor unit.
P66	Flag bit for unit of dual heat source	01: cancel the setting of dual heat source for the indoor unit 02: set the indoor unit as dual heat source 03: cancel the setting of dual heat source for all units 04: set all units as dual heat source	01	-

Parameter Code	Parameter Name	Parameter Range	Default Value	Remark
P75	Fan speed setting when heating thermostat is OFF	00: LL speed 01: OFF	00	Only valid for the cassette type unit
P80	Display temperature setting	00: display setting temperature 01: display ambient temperature	00	
P81	Functional setting of lifting panel	00: invalid 01: valid	00	Only valid for the 360° air discharge cassette type.
n0	System conservation operation settings	00: comfortability preferred 01: conservation preferred	00	-
n1	Defrosting period settings	40: 40min 50: 50min 60: 60min	50	-
n3	Forcible defrosting	00: common 01: forcible defrosting	-	After settings, it automatically restores to "00".
n4	Highest capacity output limitation settings for ODU	08: 80% 09: 90% 10: 100%	10	Enter query in "n4" status. The temperature area displays the function code and the timer area displays the corresponding function setting value.
A7	Silent function of ODU	00: no silent function 01-09: intelligent nighttime silent mode 10-12: forcible silent mode	00	Enter query in "A7" status. The temperature area displays the function code and the timer area displays the corresponding function setting value.
P47, P52-53, P57-59, P61-62, P67-68, P70, P79, qb, 4d, 4L are reserved code. Please do not set it.				

Note:

In parameter setting status, "FAN", "TIMER", "SLEEP", and "SWING" are invalid. By pressing the "ON/OFF" button, users can return to the main interface but not power on/off the unit.

In parameter setting status, signals of the remote controller are invalid.

5.1.7 Failure Display

When a fault occurs during the system operation, the temperature area of wired controller displays the fault code. When multiple faults occur, fault codes are circularly displayed.

When a fault occurs, power off the unit and ask for professional maintenance personnel for help.

The following figure shows the power-on high-pressure protection fault interface.



Power-on High-pressure Protection Fault Interface

Note:

If the IDU connected with the current wired controller is a fresh-air IDU, “FAP” is displayed on the main interface of the wired controller. Only the outlet temperature can be set for the fresh-air IDU. For the setting method, see the “IDU Function Settings” section.



5.2 Engineering Application Functions Operated through the XK49 Wired Controller



XK49 Wired Controller

5.2.1 Master IDU Settings

Method 1: In power-off status, press and hold the “MODE” button for five seconds to set the IDU connected with the current wired controller to master IDU. If the setting is successful, “MASTER” will be on.

Method 2:

Step 1: In power-on or power-off status, press and hold the “MODE” button and “SWING” simultaneously for five seconds to enter the parameter query interface.

Step 2: In “C00” status, press and hold the “MODE” button and “SWING” simultaneously for five seconds to enter the parameter setting interface.

Step 3: Press “▲” or “▼” to switch level 2 parameter codes till “P10” is displayed on the temperature area.

Step 4: Press the “MODE” button to set the parameter to “01” and then Press the “ENTER” button. If the setting is successful, “MASTER” on the wired controller will be on.



5.2.2 User Parameter Query

User parameters can be queried in power-on or power-off status.

- (1) Press and hold the “MODE” button and “SWING” simultaneously for five seconds to enter the user parameter query interface. The temperature area displays “C00” and “View” is on.
- (2) Select a parameter code by pressing “√” or “^”.
- (3) Press the “SWING” button to return to the upper-level menu till quitting parameter query.
- (4) For the user parameter query list of the XK49 wired controller, refer to the user parameter query list in XK46 user parameter query.

Note:

In parameter query, the function of “SWING” on the XK49 wired controller is equivalent to the function of “ENTER/CANCEL” on the XK46 wired controller.

5.2.3 User Parameter Settings

User parameters can be set in power-on or power-off status.

- (1) Press and hold the “MODE” button and “SWING” simultaneously for five seconds. The temperature area displays “C00”. Press and hold the “MODE” button and “SWING” simultaneously for another five seconds to enter the wired controller user parameter setting interface. The temperature area displays “P00”.
- (2) Select a parameter code by pressing “√” or “^”. Press the “MODE” button to switch to parameter value settings. The parameter value blinks. Adjust the parameter value by pressing “√” or “^” and then press the “SWING” button to complete settings.
- (3) Press the “SWING” button to return to the upper-level menu till quitting parameter settings.
- (4) For the user parameter setting list of the XK49 wired controller, refer to the user setting query list in XK46 user parameter settings.

Note:

In parameter settings, the function of “SWING” on the XK49 wired controller is equivalent to the function of “ENTER/CANCEL” on the XK46 wired controller.

5.2.4 Engineering Parameter Query

Engineering parameters can be queried in power-on or power-off status.

- (1) Press and hold the “MODE” and “SWING” button simultaneously for five seconds to enter the engineering parameter query interface. The temperature area displays “C00” and “VIEW” is on.
- (2) In “C00” status, continuously press the “MODE” button for three times to enter engineering parameter query.
- (3) Select a parameter code by pressing “√” or “^”.
- (4) Press the “SWING” button to return to the upper-level menu till quitting parameter query.
- (5) For the engineering parameter query list of the XK49 wired controller, refer to the engineering parameter query list in XK46 engineering parameter query.

Note:

In parameter query, the function of “SWING” on the XK49 wired controller is equivalent to the function of “ENTER/CANCEL” on the XK46 wired controller.

5.2.5 Engineering Parameter Settings

Engineering parameters can be set in power-on or power-off status.

- (1) Press and hold the “MODE” and “SWING” button simultaneously for five seconds. The temperature area displays “C00”. Continuously press the “MODE” button for three times, and then press and hold the “MODE” button and “SWING” simultaneously for another five seconds to enter the wired controller engineering parameter setting interface. The temperature area displays “P00”.
- (2) Select a parameter code by pressing “√” or “^”. Press the “MODE” button to switch to parameter value settings. The parameter value blinks. Adjust the parameter value by pressing “√” or “^” and then press the “SWING” button to complete settings.
- (3) Press the “SWING” button to return to the upper-level menu till quitting parameter settings.

For the engineering parameter setting list of the XK49 wired controller, refer to the engineering setting query list in XK46 engineering parameter settings.

Note:

In parameter settings, the function of “SWING” on the XK49 wired controller is equivalent to the function of “ENTER/CANCEL” on the XK46 wired controller.

5.3 Engineering Application Functions Operated through the XK79 Wired Controller



5.3.1 Master IDU Settings

The master IDU can be set through the wired controller or remote controller. The methods for setting the master IDU through the wired controller are as follows:

Method 1:

Step 1: Set an IDU to power-off status.

Step 2: Press and hold the “MODE” button on the wired controller for more than five seconds.

Step 3: Check whether the setting is successful. If it is, “MASTER” on the wired controller will be on.

Otherwise, repeat steps 1 and 2.

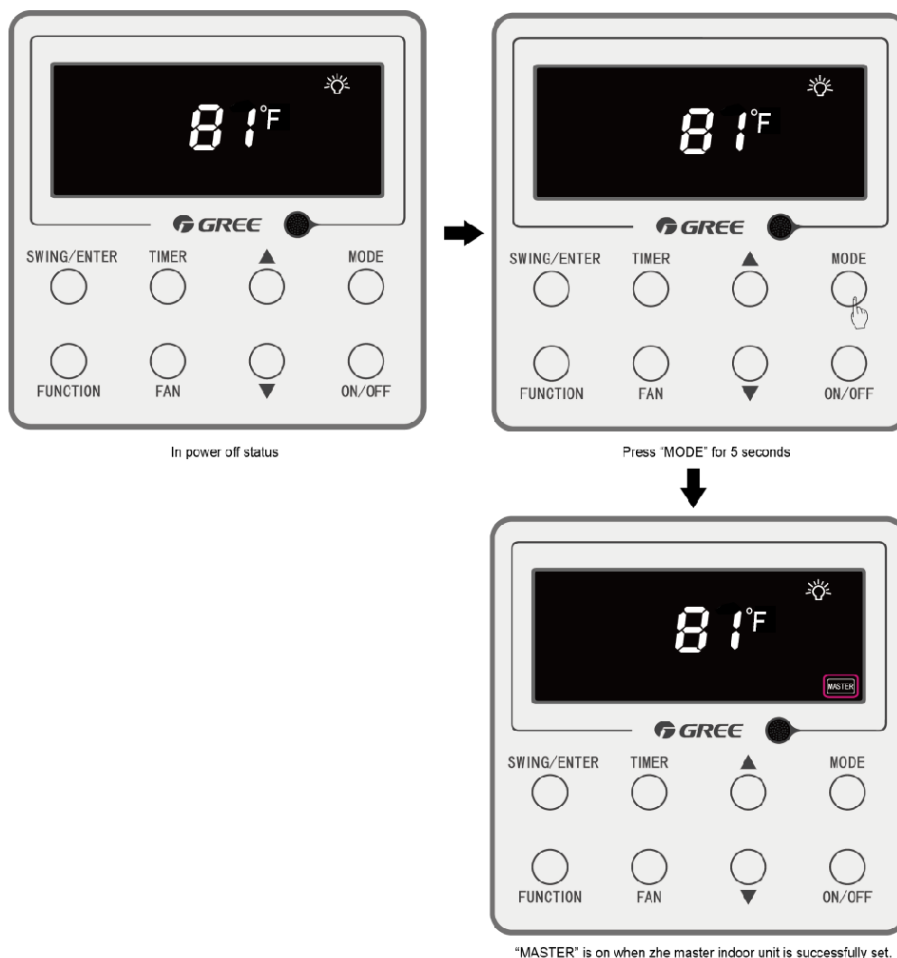

Method 2:

Step 1: Press and hold the "FUNCTION" button for five seconds in power-on or power-off status to enter the parameter query interface.

Step 2: Press and hold the "FUNCTION" button for five seconds in "C00" status to enter the parameter setting interface.

Step 3: Press "▲" or "▼" to switch level 2 parameter codes till "P10" is displayed on the temperature area.

Step 4: Press the "MODE" button to set the parameter to "01" and then Press the "SWING/ENTER" button. If the setting is successful, "MASTER" on the wired controller will be on.

Master IDU Display:

- ① For IDUs connected with wired controllers, "MASTER" on the wired controller connected with the master IDU will be on.
- ② For IDUs embedded or connected with LED panels, the operation LED on the LED panel of the master IDU will blink three times.

Note:

After the master IDU is successfully set, stick the "MASTER" flag to the wired controller or unit panel for convenience of user operation and engineering maintenance. This flag is placed in the package bag of the ODU.

5.3.2 User Parameter Query

User parameters can be queried in power-on or power-off status.

- (1) Press and hold the “FUNCTION” button for five seconds to enter the user parameter query interface. The temperature area displays “C00” and “View” is on.
- (2) Select a parameter code by pressing “▲” or “▼”.
- (3) Press the “SWING/ ENTER” button to return to the upper-level menu till quitting parameter query.
- (4) For the user parameter query list of the XK79 wired controller, refer to the user parameter query list in XK46 user parameter query.

Note:

In parameter query, the function of “SWING/ ENTER” on the XK79 wired controller is equivalent to the function of “ENTER/CANCEL” on the XK46 wired controller.

5.3.3 User Parameter Settings

User parameters can be set in power-on or power-off status.

- (1) Press and hold the “FUNCTION” button for five seconds. The temperature area displays “C00”. Press and hold the “FUNCTION” button for another five seconds to enter the wired controller user parameter setting interface. The temperature area displays “P00”.
- (2) Select a parameter code by pressing “▲” or “▼”. Press the “MODE” button to switch to parameter value settings. The parameter value blinks. Adjust the parameter value by pressing “▲” or “▼” and then press the “SWING/ ENTER” button to complete settings.
- (3) Press the “SWING/ ENTER” button to return to the upper-level menu till quitting parameter settings.
- (4) For the user parameter setting list of the XK79 wired controller, refer to the user setting query list in XK46 user parameter settings.

Note:

In parameter settings, the function of “SWING/ ENTER” on the XK79 wired controller is equivalent to the function of “ENTER/CANCEL” on the XK46 wired controller.

5.3.4 Engineering Parameter Query

Engineering parameters can be queried in power-on or power-off status.

- (1) Press and hold the “FUNCTION” button for five seconds to enter the engineering parameter query interface. The temperature area displays “C00” and “VIEW” is on.
- (2) In “C00” status, continuously press the “MODE” button for three times to enter engineering parameter query.
- (3) Select a parameter code by pressing “▲” or “▼”.
- (4) Press the “SWING/CANCEL” button to return to the upper-level menu till quitting parameter query.
- (5) For the engineering parameter query list of the XK79 wired controller, refer to the engineering parameter query list in XK46 engineering parameter query.

Note:

In parameter query, the function of “SWING/CANCEL” on the XK79 wired controller is equivalent to

the function of “ENTER/CANCEL” on the XK46 wired controller.

5.3.5 Engineering Parameter Settings

Engineering parameters can be set in power-on or power-off status.

- (1) Press and hold the “FUNCTION” button for five seconds. The temperature area displays “C00”. Continuously press the “MODE” button for three times, and then press and hold the “FUNCTION” button for another five seconds to enter the wired controller engineering parameter setting interface. The temperature area displays “P00”.
- (2) Select a parameter code by pressing “▲” or “▼”. Press the “MODE” button to switch to parameter value settings. The parameter value blinks. Adjust the parameter value by pressing “▲” or “▼” and then press the “SWING/CANCEL” button to complete settings.
- (3) Press the “SWING/CANCEL” button to return to the upper-level menu till quitting parameter settings.

For the engineering parameter setting list of the XK79 wired controller, refer to the engineering setting query list in XK46 engineering parameter settings.

Note:

In parameter settings, the function of “SWING/CANCEL” on the XK79 wired controller is equivalent to the function of “ENTER/CANCEL” on the XK46 wired controller.





5.4 Engineering Application Functions Operated through the YV1L1 Remote Controller

The YV1L1 remote controller provides all engineering application functions. It is set to common type by default upon factory departure. It can use engineering application functions only after being set to professional type. **The following only describes engineering application functions. For other user operation functions, refer to the “Remote Controller Operating Instructions”.**

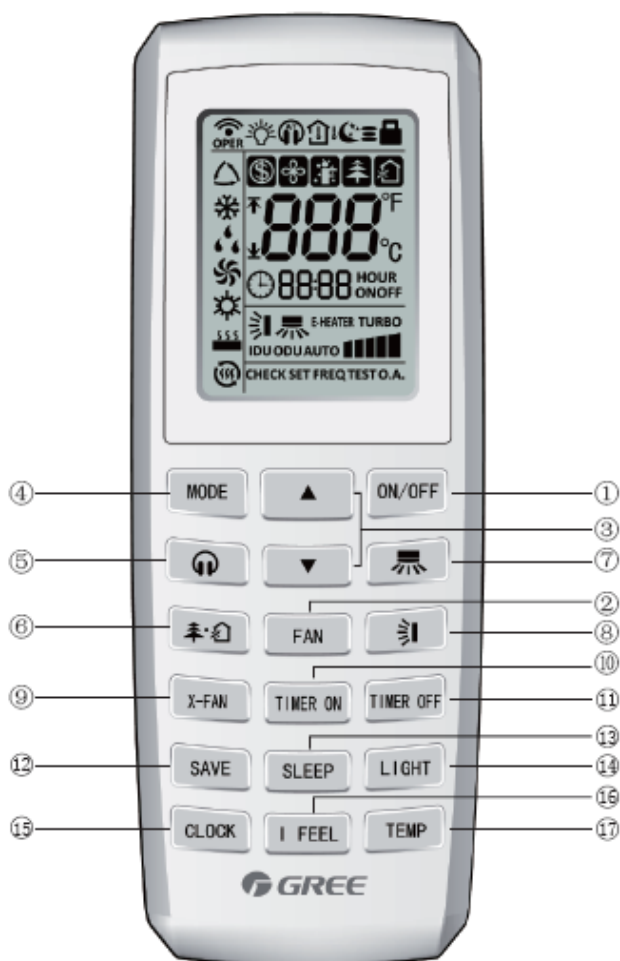
Method for setting the professional remote controller: Press “MODE” and “TEMP” simultaneously in power-off status. If “” blinks for three times, it indicates that the setting succeeds.

Method for restoring the common remote controller: Press “MODE” and “TEMP” simultaneously in power-off status. If “” blinks for three times, it indicates that the setting succeeds.



No.	Button name	Function
1	ON/OFF	Turn on or turn off the unit
2	FAN	Set fan speed
3	▲/▼	Set temperature and time
4	MODE	Set operation mode
5		Set quiet function
6		Set health function and air function
7		Set left & right swing status
8		Set up & down swing status

No.	Button name	Function
9	X-FAN	Set X-FAN function
10	TIMER ON	Set timer on function
11	TIMER OFF	Set timer off function
12	SAVE	Set energy-saving function
13	SLEEP	Set sleep function
14	LIGHT	Set light function
15	CLOCK	Set clock of the system
16	I FEEL	Set I FEEL function
17	TEMP	Switch temperature displaying type on the unit's display

5.4.1 Master IDU Settings

The master IDU can be set through the wired controller or remote controller. The methods for setting the master IDU through the remote controller are as follows:

Step 1: Set an IDU to air-supply status and set the temperature to 30°C.

Step 2: Continuously press “—” and “+” for three times within five seconds.

Step 3: Check whether the setting is successful. If it is, the LED panel of the IDU will display “UC” for five seconds and “MASTER” on the wired controller will be on. Otherwise, repeat steps 1 and 2.

5.4.2 Parameter Query

Engineering application functions cover parameter query and parameter settings.

For parameter query, users can query user parameters and engineering parameters of the unit. The parameter query method is as follows:

(1) On the professional remote controller of YV1L1, press and hold “” for five seconds to enter the parameter query status. The viewing text is displayed. The query code “C00” blinks in the temperature area.

(2) Press “” to switch the query code and select a unit parameter to be queried (see Table 2.5 for parameters that can be queried).

(3) If the timer area displays query sub-items, it indicates that there are level 2 query menus. Press “” to enter level 2 query menu selection. The content blinks in the timer area. Press



“” to switch query sub-items and select a level 2 menu to be queried.

(4) Press “” to confirm query and return to step 2.



After entering the engineering application function, the system automatically quits the engineering commissioning status if no valid operations are performed within 20 seconds. To directly quit the engineering commissioning status, press “”.

Table 2.5 Query Parameters



Query Code	Query Content	Query Sub-item	Level 2 Query Content
C00	Invalid		
C01	Project number query of the current IDU		
C02	Capacity query of the current IDU		
C03	Indoor unit quantity query in the CAN1 network		
C04	Project number query of the master IDU		
C05	Historical fault query ingress of the current IDU	01	Fault 1
		02	Fault 2
		03	Fault 3
		04	Fault 4
		05	Fault 5
C06	Preferential operation query		
C07	Temperature query for environment temperature sensor of the current IDU		
C08	Prompt time query for air filter cleaning		
C10	Static pressure setting query of ODU	01	Module 1
		02	Module 2
		03	Module 3
		04	Module 4
C11	Indoor unit quantity query in one-to-many control mode		
C12	Temperature query for outdoor environment temperature sensor		
C13	CAN2 bus line ID query		
C14	Inlet-tube temperature query of IDU		
C15	Outlet temperature query of IDU		
C16	Opening degrees query of electronic expansion valve of IDU		
n2	Capacity configuration ratio upper-limit query of outdoor and IDUs		
n4	Highest capacity output limitation query		
n6	Historical fault query ingress of ODU	01	Fault 1
		02	Fault 2
		03	Fault 3
		04	Fault 4
		05	Fault 5
A6	Unit cooling/heating function		
A7	Outdoor silent mode		

5.4.3 Parameter Settings

For parameter settings, users can set user parameters and engineering parameters of the unit. The parameter setting method is as follows:

- (1) After entering parameter query, switch the query code to “C00”. Press and hold “” for five seconds to enter the parameter setting status. The setting text is displayed and “P00” blinks in the temperature area.

- (2) Press “” to switch the setting code and select a unit parameter to be set (see Table 2.6 for parameters that can be set).

- (3) Press “” to enter parameter settings. The current parameter value blinks in the timer area. Press “” to change the parameter value.

- (4) Press “” to confirm query and return to step 2.

After entering engineering commissioning, the system automatically quits the engineering

commissioning status if no valid operations are performed within 20 seconds. To directly quit the engineering commissioning status, press “”.

Table 2.6 Setting Parameters

Setting Code	Setting Content	Setting Value
P00	Invalid	--
P10	Master IDU settings	00: not changing the current settings 01: setting the corresponding IDU to master IDU 001-255: setting the IDU corresponding to *** to master IDU
P15	Power-down memory mode settings	00: standby after power-down recovery 01: restoring the original status after power-down recovery
P17	Historical fault clearing	00: not cleared 01: cleared
P20	Indoor environment temperature value	01: temperature sensor of air return vent 02: temperature sensor of wired controller 03: temperature sensor of air return vent for cooling, dehumidifying, and air supply; temperature sensor of wired controller for heating 04: temperature sensor of wired controller for cooling, dehumidifying, and air supply; temperature sensor of air return vent for heating and automatic mode
P21	Corrected value settings of environment temperature sensor of IDU (for cooling, dehumidifying, and air supply)	-15 to 15
P22	Corrected value settings of environment temperature sensor of IDU (for heating)	-15 to 15
P30	Static pressure settings for indoor fan	Type 1: 03.04.05.06.07 Type 2: 01.02.03.04.05.06.07.08.09
P31	High-ceiling installation settings	00: standard-ceiling installation height 01: high-ceiling installation height
P32	Capacity adjustment function of IDU	-40% to +40%
P34	Repeating validity for time-point timing	00: invalid 01: valid
P35	Factory setting recovery for user functions	00: invalid 01: factory setting recovery
P36	Factory setting recovery for engineering settings	00: invalid 01: factory setting recovery
P40	Prevention for heat collection	00: disabled 10: 10 seconds 20: 20 seconds 30: 30 seconds 40: 40 seconds 50: 50 seconds 60: 60 seconds
P42	Project number settings of IDU	1-255
P43	Preferential operation settings	00: no preferential operation 01: preferential operation
P44	One-key project number setting query for IDU	00: not displayed 01: displayed
P45	One-key project number reset for IDU	00: invalid 01: project number reset
P46	Accumulated time clearing for air filter cleaning	00: not cleared 01: cleared

Setting Code	Setting Content	Setting Value
P47	Prompt settings for air filter cleaning	00: no cleaning prompt settings 10-39: The first digit indicates the pollution degree of the using place and the second digit indicates the accumulated operating time of IDU. The two digits are described as follows: ① Slight pollution: The first digit is "1". If the second digit is "0", it indicates that the accumulated operating time is 5500 hours. The accumulated operating time is added by 500 hours when the second digit is increased by "1". When the second digit is "9", the accumulated operating time is 10000 hours. ② Medium pollution: The first digit is "2". If the second digit is "0", it indicates that the accumulated operating time is 1400 hours. The accumulated operating time is added by 400 hours when the second digit is increased by "1". When the second digit is "9", the accumulated operating time is 5000 hours. ③ Heavy pollution: The first digit is "3". If the second digit is "0", it indicates that the accumulated operating time is 100 hours. The accumulated operating time is added by 100 hours when the second digit is increased by "1". When the second digit is "9", the accumulated operating time is 1000 hours.
n0	System conservation operation settings	00: comfortability preferred 01: conservation preferred
n1	Defrosting period settings	40: 40 minutes 50: 50 minutes 60: 60 minutes
n3	Forcible defrosting	00: no defrosting 01: forcible defrosting
A7	Silent function of ODU	00: no silent function 01-09: intelligent nighttime silent mode 10-12: forcible silent mode
n4	Highest capacity output limitation settings	08: highest energy consumption limitation being 80% 09: highest energy consumption limitation being 90% 10: no conservation limitation

5.5 Engineering Application Functions Operated through the YAP1F Remote Controller

The YAP1F remote controller only provides engineering application functions for setting the master IDU. For other user operation functions, refer to the “*Remote Controller Operating Instructions*”.

The method for setting the master IDU through the YAP1F remote controller is as follows:

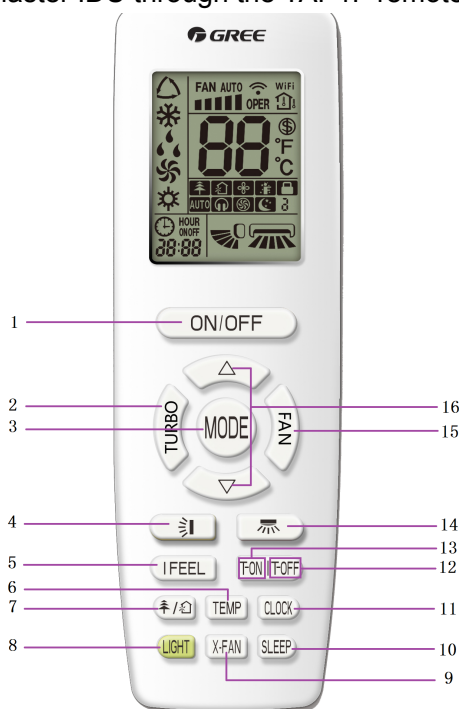

No.	Button name	Function
1	ON/OFF	Turn on or turn off the unit
2	TURBO	Set turbo function
3	MODE	Set operation mode
4		Set up&down swing status
5	I FEEL	Set I FEEL function
6	TEMP	Switch temperature displaying type on the unit's display
7		Set health function and air function
8	LIGHT	Set light function
9	X-FAN	Set X-FAN function
10	SLEEP	Set sleep function
11	CLOCK	Set clock of the system
12	TOFF	Set timer off function
13	TON	Set timer on function
14		Set left&right swing status
15	FAN	Set fan speed
16		Set temperature and time

(For details about the above figures, refer to the instructions 66174100016).

Perform settings by pressing “▲” and “▼” in air supply mode:

- ① Set the temperature to 30°C.
- ② Press “▼” and then “▲” in five seconds. Repeat this operation for three times.
- ③ After successful settings, “UC” is displayed on the receiving indicator panel of the remote controller for five seconds and “MASTER” is displayed on the wired controller.

INSTALLATION

1 Engineering Installation Preparation and Notice

1.1 Installation Notice

Personnel and property safety are highly concerned during the entire installation process. Installation implementation must abide by relevant national safety regulations to ensure personnel and property safety.

All personnel involved in the installation must attend safety education courses and pass corresponding safety examinations before installation. Only qualified personnel can attend the installation. Relevant personnel must be held responsible for any violation of the regulation.

1.2 Installation Key Points and Importance

VRF air conditioning systems use refrigerant, instead of other agent, to directly evaporate to carry out the system heat. High level of pipe cleanness and dryness is required in the system. Since various pipes need to be prepared and laid out onsite, carelessness or maloperation during installation may leave impurities, water, or dust inside refrigerant pipes. If the design fails to meet the requirement, various problems may occur in the system or even lead to system breakdown.

Problems that usually occur during installation are as follows:

No.	Installation Problem	Possible Consequence
1	Dust or impurities enter into the refrigeration system.	Pipes are more likely to be blocked; air conditioning performance is reduced; compressor wear is increased or even hinder the normal operation of the system and burn the compressor.
2	Nitrogen is not filled into the refrigerant pipe or insufficient Nitrogen is filled before welding.	Pipes are more likely to be blocked; air conditioning performance is reduced; compressor wear is increased or even hinder the normal operation of the system and burn the compressor.
3	The vacuum degree in the refrigerant pipe is insufficient.	The refrigeration performance is reduced. The system fails to keep normal operation due to frequent protection measures. When the problem getting serious, compressor and other major components can be damaged.
4	Water enters into the refrigeration system.	Copper plating may appear on the compressor and reduce the compressor efficiency with abnormal noise generated; failures may occur in the system due to ice plug.
5	The refrigerant pipe specifications do not meet the configuration requirements.	Smaller configuration specifications can increase the system pipe resistance and affect the cooling performance; larger configuration specifications are waste of materials and can also reduce the cooling performance.
6	Refrigerant pipe is blocked.	The cooling performance is reduced; in certain cases, it may cause long-term compressor operating under overheating conditions; the lubricating effect can be affected and the compressor may be burnt if impurities were mixed with the lubricating oil.
7	Refrigerant pipe exceeds the limit.	The loss in pipe is considerable and the unit energy efficiency decreases, which are harmful for long-term running of the system.
8	Incorrect amount of refrigerant is filled.	The system cannot correctly control the flow allocation; the compressor may be operating under over-heating environment or running when the refrigerant flows back to the compressor.
9	The refrigerant pipe leaks.	Insufficient refrigerant circulating in the system decreases the cooling performance of the air conditioner. Long-term operation under such circumstance may cause an overheating compressor or even damage the compressor.
10	Water drainage from the condensate water pipe is not smooth.	Residual water in IDUs can affect the normal operation of the system. The possible water leakage can damage the IDU's decoration.
11	The ratio of slop for condensate water pipe is insufficient or the condensate water pipe is incorrectly connected.	Reverse slop or inconsistent connection of condensate water pipe can hinder the smooth drainage and cause leakage of the IDU.
12	The air channel is improperly fixed.	The air channel will deform; vibration and noise occur during unit operating.

No.	Installation Problem	Possible Consequence
13	The guide vane of air channel is not reasonably manufactured.	Uneven air quantity allocation reduces the overall performance of the air conditioner.
14	The refrigerant pipe or condensate water pipe does not meet the insulation requirement.	Water can easily condensate and drip to damage the indoor decoration, or even trigger the protection mode of system due to overheating operation.
15	The installation space for IDU is insufficient.	Since there is a lack of space for maintenance and checking, indoor decoration might need to be damaged during such operation.
16	The IDU or the location of the air outlet or return air inlet is not designed reasonably.	The air outlet or return air inlet may be short-circuited, thus affecting the air conditioning performance.
17	The ODU is improperly installed.	The ODU is difficult to be maintained; unit exhaust is not smooth, which reduces the heat exchanging performance or even prevent the system from normal operation; in addition, the cold and hot air for heat exchange and the noise may annoy people in surrounding areas.
18	Power cables are incorrectly provided.	Unit components may be damaged and potential safety hazard may occur.
19	Control communication cables are incorrectly provided or improperly connected.	The normal communication in the system fails or the control over IDUs and ODUs turn in a mess.
20	Control communication cables are not properly protected.	The communication cables are short-circuited or disconnected, and the unit cannot be started up due to communication failure.

Understand the special requirement (if any) for unit installation before implementation to ensure installation quality. Relevant installers must have corresponding engineering construction qualifications.

Special type operators involved in the engineering implementation, such as welders, electricians, and refrigeration mechanics must have relevant operating licenses and are accredited with vocational qualification certification.

2 Installation Materials Selection

The materials, equipment and instruments used during air conditioning engineering construction must have certifications and test reports. Products with fireproof requirements must be provided with fireproof inspection certificates and must meet national and relevant compulsory standards. If environmentally-friendly materials are to be used as required by customers, all such materials must meet national environmental protection requirement and be provided with relevant certificates.

2.1 Refrigerant Piping

- (1) Material requirement: Dephosphorization drawing copper pipe for air conditioners;
- (2) Appearance requirement: The inner and outer surface of pipe should be smooth without pinhole, crack, peeling, blister, inclusion, copper powder, carbon deposition, rust, dirt or severe oxide film, and without obvious scratch, pit, spot and other defects.
- (3) Test report: Certifications and quality test reports must be provided.
- (4) The tensile strength must be at least 240 kgf/mm².

Specifications requirement

R410A Refrigerant System		
OD (mm/inch)	Wall Thickness (mm)	Model
Φ6.35(1/4)	≥0.8	0
Φ9.52(3/8)	≥0.8	0
Φ12.70(1/2)	≥0.8	0
Φ15.9(5/8)	≥1.0	0
Φ19.05(3/4)	≥1.0	0

- (5) After the inner part of the copper pipe is cleaned and dried, the inlet and outlet must be sealed tightly by using pipe caps, plugs or adhesive tapes.

2.2 Condensate Water Pipe

- (1) Pipes that can be used for air conditioner drainage include: water supplying UPVC pipe, PP-R pipe, PP-C pipe, and HDG steel pipe;
- (2) All relevant certificates and quality test reports are provided.
- (3) Requirements for specifications and wall thickness.

Water supplying UPVC pipe: $\Phi 32\text{mm} \times 2\text{mm}$, $\Phi 40\text{mm} \times 2\text{mm}$, $\Phi 50\text{mm} \times 2.5\text{mm}$;

HDG steel pipe: $\Phi 25\text{mm} \times 3.25\text{mm}$, $\Phi 32\text{mm} \times 3.25\text{mm}$, $\Phi 40\text{mm} \times 3.5\text{mm}$, $\Phi 50\text{mm} \times 3.5\text{mm}$.

2.3 Insulation Material

- (1) Rubber foam insulation material;
- (2) Flame retardancy level: B1 or higher;
- (3) Refractoriness: at least 120°C ;
- (4) The insulation thickness of condensate water pipe: at least 10 mm;
- (5) When the diameter of copper pipe is equal to or greater than $\Phi 15.9$ mm, the thickness of insulation material should be at least 20 mm; when the diameter of copper pipe is less than 15.9 mm, the thickness of insulation material should be at least 15 mm.

2.4 Communication Cable and Control Cable

Note:

For air conditioning units installed in places with strong electromagnetic interference, shielded wire must be used as the communication cables of the IDU and wired controller, and shielded twisted pairs must be used as the communication cables between IDUs and between the IDU and ODU.

Communication cable selection for IDU and IDU(ODU)

Material Type	Total Length of Communication Cable between IDU Unit and IDU (ODU) Unit L(m/ft)	Wire size (mm ² /AWG)	Material Standard	Remarks
Light/Ordinary polyvinyl chloride sheathed cord. (60227 IEC 52 /60227 IEC 53)	$L \leq 1000(3280-5/6)$	$\geq 2 \times 0.75$ ($\geq 2 \times \text{AWG}18$)	IEC 60227-5:20 07	<ol style="list-style-type: none"> 1. If the wire diameter is enlarged to $2 \times 1 \text{ mm}^2$ ($2 \times \text{AWG}16$), the total communication line length can reach 1500 m (4921-1/4ft). 2. The cord shall be Circular cord (the cores shall be twisted together). 3. If unit is installed in places with intense magnetic field or strong interference, it is necessary to use shielded wire.

Communication cable selection for IDU and wired controller

Material type	Total length of communication Cable between IDU unit and wired controller L(m/ft)	Wire size (mm ² /AWG)	Material standard	Remarks
Light/Ordinary polyvinyl chloride sheathed cord. (60227 IEC 52 /60227 IEC 53)	L≤250(820-1/5)	2×0.75~2×1.25 (2×AWG18~2×AWG16)	IEC 60227-5:2007	<ol style="list-style-type: none"> Total length of communication line can't exceed 250m (820-1/5ft). The cord shall be Circular cord (the cores shall be twisted together). If unit is installed in places with intense magnetic field or strong interference, it is necessary to use shielded wire.

2.5 Power Cable

Only copper conductors can be used as power cables. The copper conductors must meet relevant national standard and satisfy the carrying capacity of unit.

2.6 Hanger Rod and Support

- (1) Hanger rod: M8 or M10;
- (2) U-steel: 14# or above;
- (3) Angle steel: 30mm×30mm×3mm or above;
- (4) Round steel: Φ10mm or above.

3 Installation of Indoor Unit

3.1 Installation of Floor Standing Indoor Unit

3.1.1 Outline and installation dimension

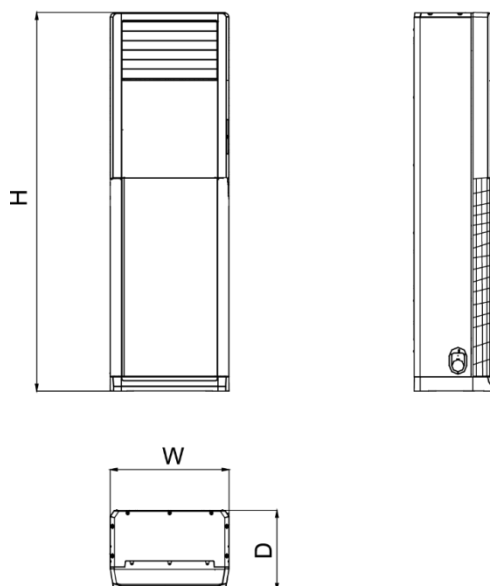

Unit: mm

Model	W	H	D
GMV-ND100L/A-T GMV-ND140L/A-T	580	1870	400

3.1.2 Installation space

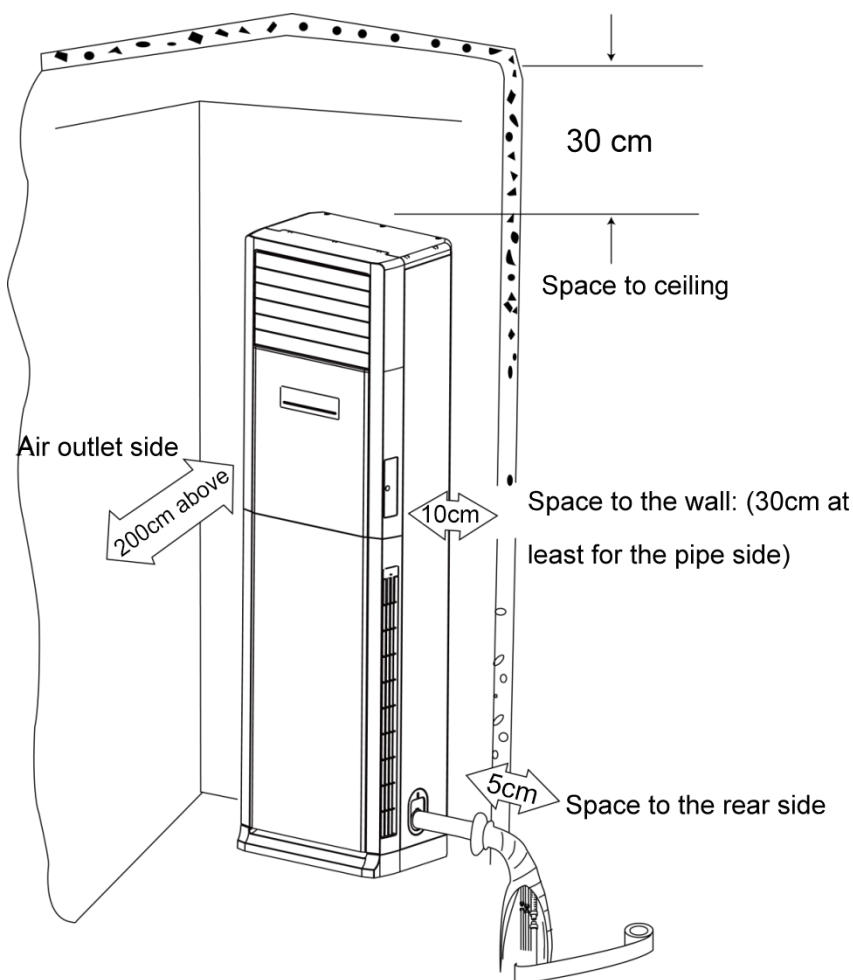

3.1.3 Installation notice

- ◆ The unit shall be installed by the professional personnel according to this installation instruction to ensure proper use.
- ◆ Please contact the local Gree appointed service center before installation. Any malfunction caused by the unit that is not installed by the Gree appointed service center would probably not be dealt with on time because of the inconvenience of the business contact.
- ◆ It should be guided under the professional personnel when the air conditioner unit is moved to other place.

3.1.4 Selection of air switch and power cord

Model	Power Cord Size	Air Switch Capacity (A)	Minimum Sectional Area of Ground Wire (mm ² /AWG)	Minimum Sectional Area of Power Cord (mm ² /AWG)
GMV-ND100L/A-T	220V~240V/50Hz 208V/230V/60Hz	6	1.0/AWG18	1.0/AWG18
GMV-ND140L/A-T	220V~240V/50Hz 208V/230V/60Hz	6	1.0/AWG18	1.0/AWG18

3.2 Installation of High Static Pressure Duct Type Unit

3.2.1 Outline and installation dimension

Model: GMV-ND56PHS/A-T~ GMV-ND160PHS/A-T

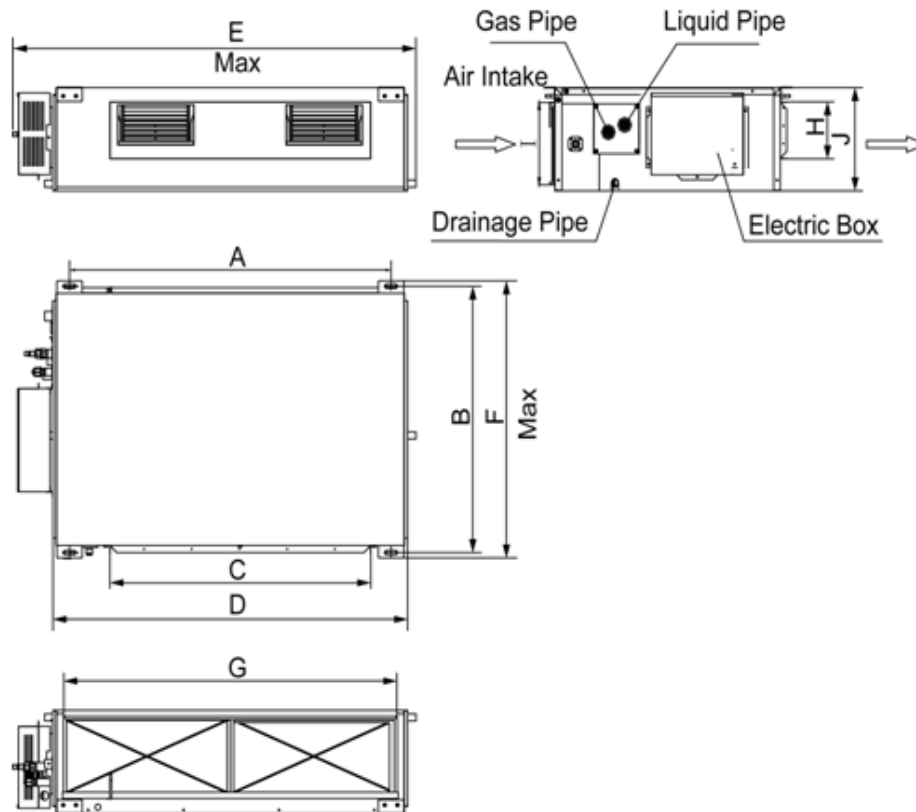

Below are dimensions of A, B, C, etc. for different models:

Unit: mm

Model	A	B	C	D	E	F	G	H	I	J
GMV-ND56PHS/A-T	1101	517	820	1159	1271	558	1002	160	235	268
GMV-ND63PHS/A-T										
GMV-ND71PHS/A-T										
GMV-ND80PHS/A-T										
GMV-ND90PHS/A-T	1011	748	820	1115	1229	775	979	160	231	290
GMV-ND100PHS/A-T										
GMV-ND112PHS/A-T										
GMV-ND125PHS/A-T										
GMV-ND140PHS/A-T										
GMV-ND160PHS/A-T	1177	646	852	1150	1340	750	953	190	316	350

Model: GMV-ND224PH/A-T, GMV-ND280PH/A-T

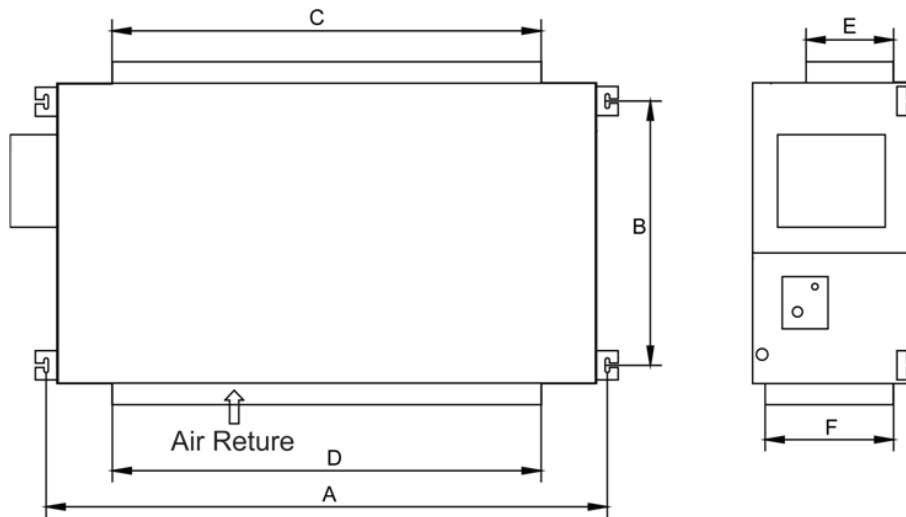

Below are dimensions of A, B, C, etc. for different models:

Unit: mm

Model	A	B	C	D	E	F
GMV-ND224PH/A-T	1353	632	992	1150	192	327
GMV-ND280PH/A-T	1563	706	992	1350	192	402

3.2.2 Installation space

Model: GMV-ND56PHS/A-T~ GMV-ND160PHS/A-T

Unit: mm

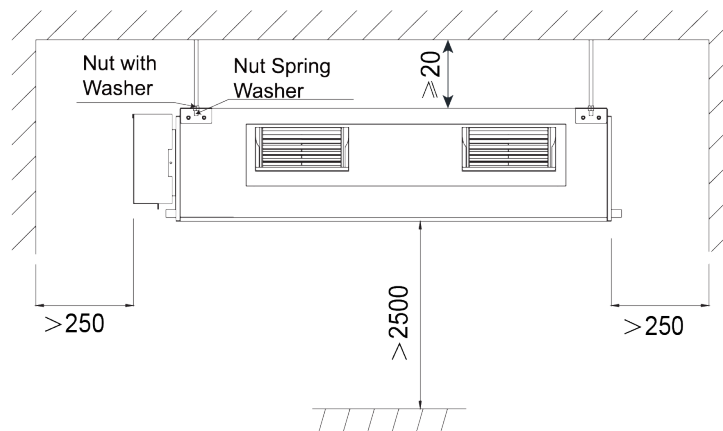

Model: GMV-ND224PH/A-T, GMV-ND280PH/A-T

Unit: mm

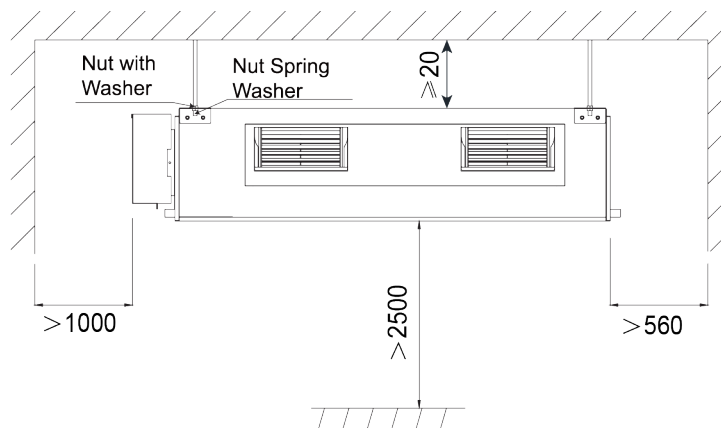

3.2.3 Installation notice

- ◆ The unit shall be installed by the professional personnel according to this installation instruction to ensure proper use.
- ◆ Please contact the local Gree appointed service center before installation. Any malfunction caused by the unit that is not installed by the Gree appointed service center would probably not be dealt with on time because of the inconvenience of the business contact.
- ◆ It should be guided under the professional personnel when the air conditioner unit is moved to other place.
- ◆ Installation of the unit must be in accordance with National Electric Codes and local regulations.
- ◆ Improper installation will affect unit's performance, so do not install the unit by yourself. Please contact local dealer to arrange professional technicians for the installation.
- ◆ Do not connect power until all installation work is finished.
- ◆ If the supply cord is damaged, it must be replaced by the manufacturer or its service agent or a similarly qualified person in order to avoid a hazard.

3.2.4 Selection of air switch and power cord

Model	Power Cord Size	Air Switch Capacity (A)	Minimum Sectional Area of Ground Wire (mm ² /AWG)	Minimum Sectional Area of Power Cord (mm ² /AWG)
GMV-ND56PHS/A-T	220-240V/50Hz 208-230V/60Hz	6	1.0/AWG18	1.0/AWG18
GMV-ND63PHS/A-T	220-240V/50Hz 208-230V/60Hz	6	1.0/AWG18	1.0/AWG18
GMV-ND71PHS/A-T	220-240V/50Hz 208-230V/60Hz	6	1.0/AWG18	1.0/AWG18
GMV-ND80PHS/A-T	220-240V/50Hz 208-230V/60Hz	6	1.0/AWG18	1.0/AWG18
GMV-ND90PHS/A-T	220-240V/50Hz 208-230V/60Hz	6	1.0/AWG18	1.0/AWG18
GMV-ND100PHS/A-T	220-240V/50Hz 208-230V/60Hz	6	1.0/AWG18	1.0/AWG18
GMV-ND112PHS/A-T	220-240V/50Hz 208-230V/60Hz	6	1.0/AWG18	1.0/AWG18
GMV-ND125PHS/A-T	220-240V/50Hz 208-230V/60Hz	6	1.0/AWG18	1.0/AWG18
GMV-ND140PHS/A-T	220~240V/50Hz 208~230V/60Hz	6	1.0/AWG18	1.0/AWG18
GMV-ND160PHS/A-T	220-240V/50Hz 208-230V/60Hz	6	1.0/AWG18	1.0/AWG18
GMV-ND224PH/A-T	220-240V/50Hz 208-230V/60Hz	10	1.0/AWG18	1.0/AWG18
GMV-ND280PH/A-T	220-240V/50Hz 208-230V/60Hz	16	1.0/AWG18	1.0/AWG18

3.3 Installation of Low Static Pressure Duct Type Unit

3.3.1 Outline and installation dimension

Model: GMV-ND22PLS/A-T~GMV-ND63PLS/A-T

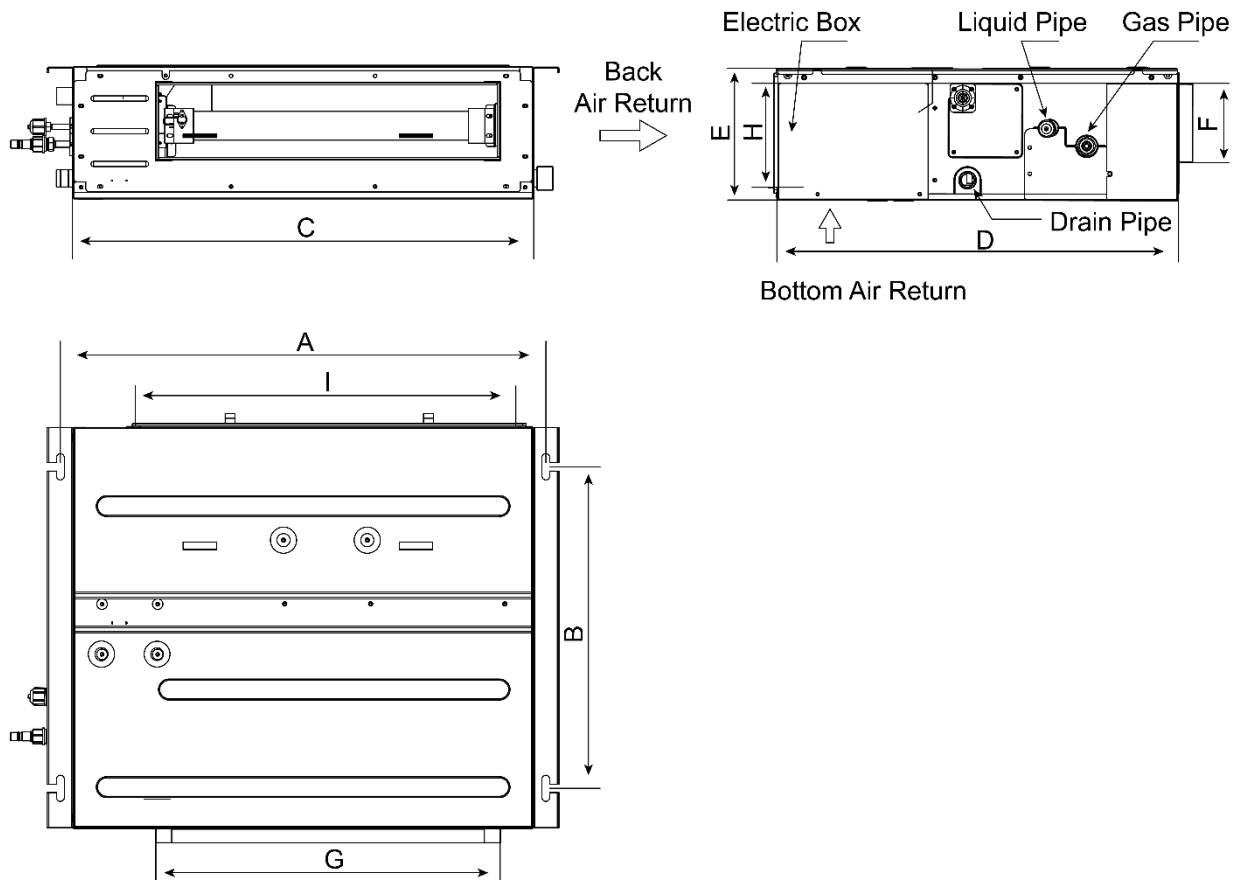

Below are dimensions of A, B, C etc. for different models:

Unit: mm

Model	A	B	C	D	E	F	G	H	I
GMV-ND22PLS/A-T	742	491	700	615	200	121	528	161	580
GMV-ND25PLS/A-T									
GMV-ND28PLS/A-T									
GMV-ND32PLS/A-T									
GMV-ND36PLS/A-T									
GMV-ND40PLS/A-T	942	491	900	615	200	121	728	161	780
GMV-ND45PLS/A-T									
GMV-ND50PLS/A-T									
GMV-ND56PLS/A-T	1142	491	1100	615	200	121	928	161	980
GMV-ND63PLS/A-T									

Model: GMV-ND71PLS/A-T~GMV-ND140PLS/A-T

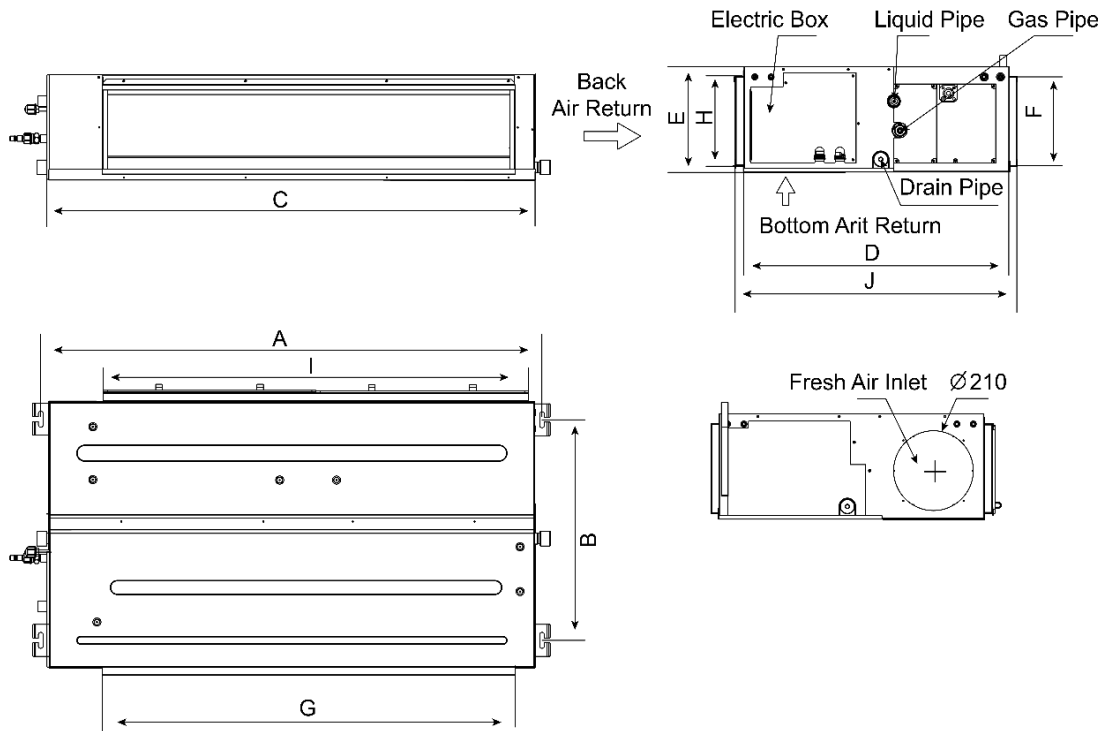

Below are dimensions of A, B, C etc. for different models:

Unit: mm

Model	A	B	C	D	E	F	G	H	I	J
GMV-ND71PLS/A-T	1236	565	1200	655	260	222	1016	220	1050	695
GMV-ND80PLS/A-T										
GMV-ND90PLS/A-T	1379	565	1340	655	260	207	1153	220	1188	716
GMV-ND100PLS/A-T										
GMV-ND112PLS/A-T										
GMV-ND125PLS/A-T										
GMV-ND140PLS/A-T										

Model: GMV-ND18PLS/C-T~GMV-ND71PLS/C-T

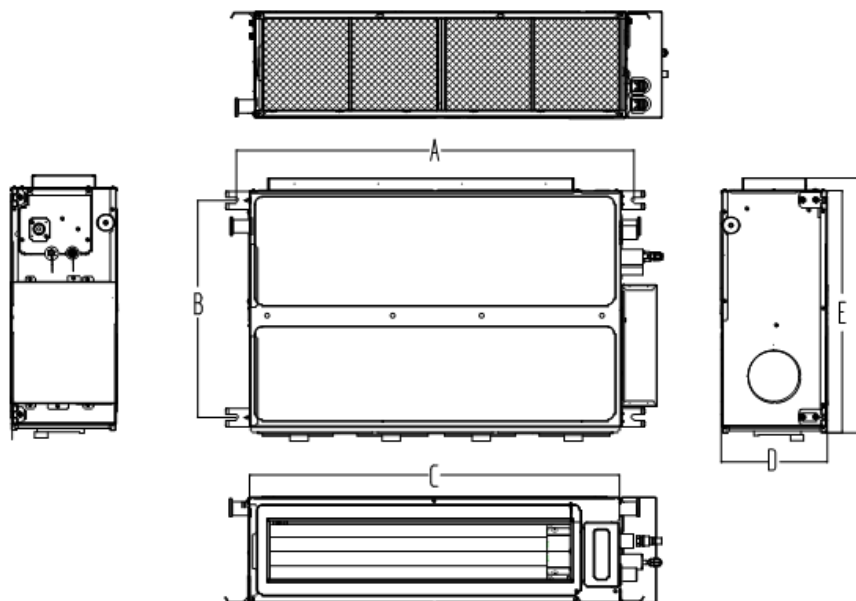

The table below lists the detailed dimensions.

Unit: mm

Model	A	B	C	D	E	F
GMV-ND18~36PLS/C-T	760	415	710	200	462	486
GMV-ND40~63PLS/C-T	1060	415	1010	200	462	486
GMV-ND71PLS/C-T	1360	415	1310	200	462	486

Model: GMV-ND80PLS/C-T~GMV-ND140PLS/C-T

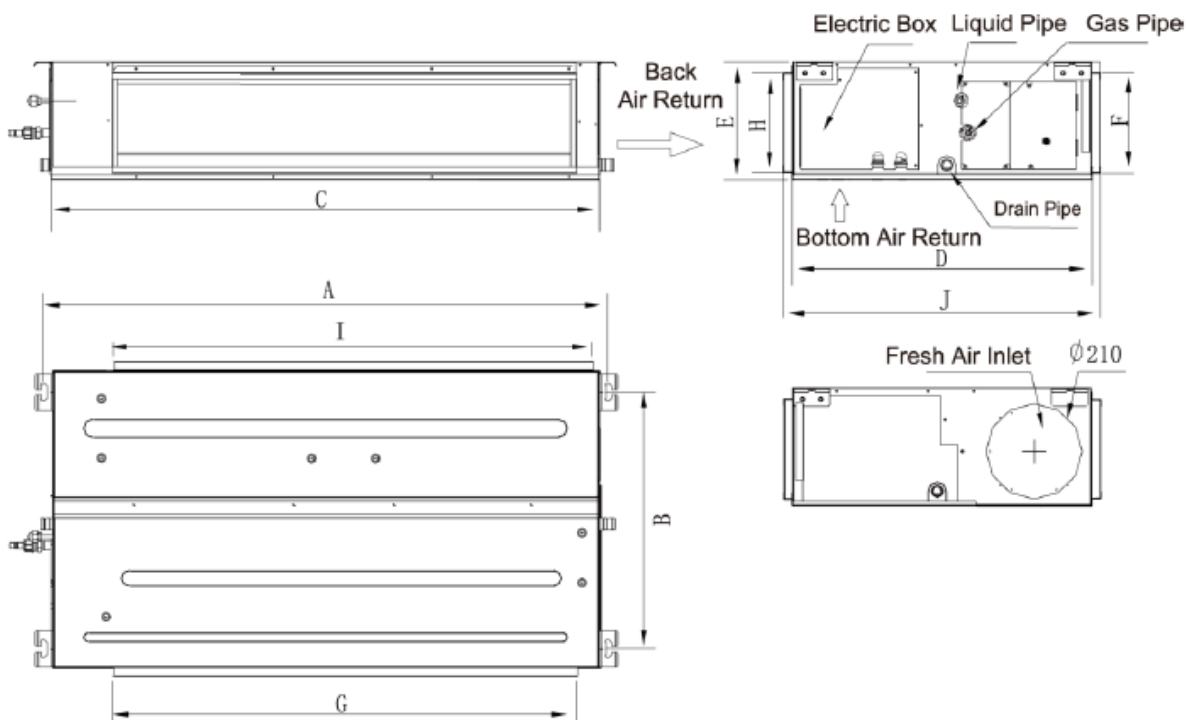

The table below lists the detailed dimensions.

Unit: mm

Model	A	B	C	D	E	F	G	H	I	J
GMV-ND80PLS/C-T	1236	565	1200	655	260	222	1016	220	1050	695
GMV-ND90PLS/C-T	1379	565	1340	655	260	207	1153	220	1188	716
GMV-ND100PLS/C-T										
GMV-ND112PLS/C-T										
GMV-ND125PLS/C-T										
GMV-ND140PLS/C-T										

3.3.2 Installation space

Unit: mm

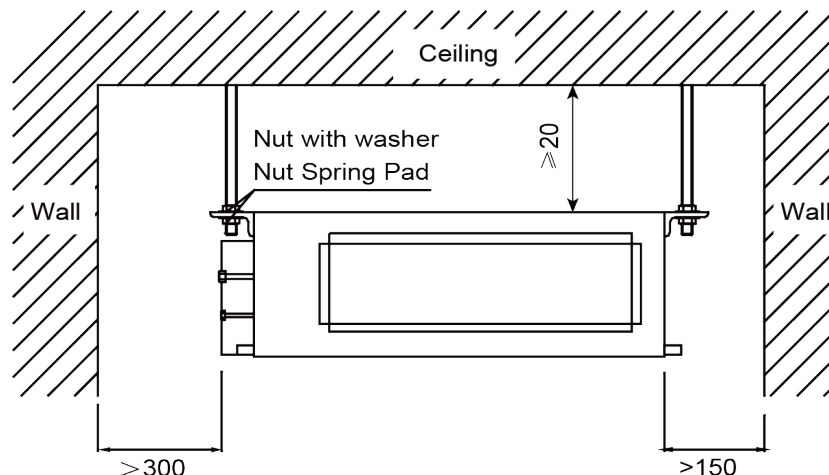

3.3.3 Installation notice

- ◆ The unit shall be installed by the professional personnel according to this installation instruction to ensure proper use.
- ◆ Please contact the local Gree appointed service center before installation. Any malfunction caused by the unit that is not installed by the Gree appointed service center would probably not be dealt with on time because of the inconvenience of the business contact.
- ◆ It should be guided under the professional personnel when the air conditioner unit is moved to other place.
- ◆ Installation of the unit must be in accordance with National Electric Codes and local regulations.
- ◆ Improper installation will affect unit's performance, so do not install the unit by yourself. Please contact local dealer to arrange professional technicians for the installation.
- ◆ Do not connect power until all installation work is finished.

3.3.4 Selection of air switch and power cord

Model	Power Cord Size	Air Switch Capacity (A)	Minimum Sectional Area of Ground Wire (mm ² /AWG)	Minimum Sectional Area of Power Cord (mm ² /AWG)
GMV-ND22PLS/A-T	220-240V/50Hz 208-230V/60Hz	6	1.0/AWG18	1.0/AWG18
GMV-ND25PLS/A-T	220-240V/50Hz 208-230V/60Hz	6	1.0/AWG18	1.0/AWG18
GMV-ND28PLS/A-T	220-240V/50Hz 208-230V/60Hz	6	1.0/AWG18	1.0/AWG18
GMV-ND32PLS/A-T	220-240V/50Hz 208-230V/60Hz	6	1.0/AWG18	1.0/AWG18
GMV-ND36PLS/A-T	220-240V/50Hz 208-230V/60Hz	6	1.0/AWG18	1.0/AWG18
GMV-ND40PLS/A-T	220-240V/50Hz 208-230V/60Hz	6	1.0/AWG18	1.0/AWG18
GMV-ND45PLS/A-T	220-240V/50Hz 208-230V/60Hz	6	1.0/AWG18	1.0/AWG18
GMV-ND50PLS/A-T	220-240V/50Hz 208-230V/60Hz	6	1.0/AWG18	1.0/AWG18
GMV-ND56PLS/A-T	220-240V/50Hz 208-230V/60Hz	6	1.0/AWG18	1.0/AWG18

Model	Power Cord Size	Air Switch Capacity (A)	Minimum Sectional Area of Ground Wire (mm ² /AWG)	Minimum Sectional Area of Power Cord (mm ² /AWG)
GMV-ND63PLS/A-T	220-240V/50Hz 208-230V/60Hz	6	1.0/AWG18	1.0/AWG18
GMV-ND71PLS/A-T	220-240V/50Hz 208-230V/60Hz	6	1.0/AWG18	1.0/AWG18
GMV-ND80PLS/A-T	220-240V/50Hz 208-230V/60Hz	6	1.0/AWG18	1.0/AWG18
GMV-ND90PLS/A-T	220-240V/50Hz 208~230V/60Hz	6	1.0/AWG18	1.0/AWG18
GMV-ND100PLS/A-T	220-240V/50Hz 208-230V/60Hz	6	1.0/AWG18	1.0/AWG18
GMV-ND112PLS/A-T	220-240V/50Hz 208-230V/60Hz	6	1.0/AWG18	1.0/AWG18
GMV-ND125PLS/A-T	220-240V/50Hz 208-230V/60Hz	6	1.0/AWG18	1.0/AWG18
GMV-ND140PLS/A-T	220-240V/50Hz 208-230V/60Hz	6	1.0/AWG18	1.0/AWG18
GMV-ND18PLS/C-T	220-240V/50Hz 208-230V/60Hz	6	1.0/AWG18	1.0/AWG18
GMV-ND22PLS/C-T	220-240V/50Hz 208-230V/60Hz	6	1.0/AWG18	1.0/AWG18
GMV-ND25PLS/C-T	220-240V/50Hz 208-230V/60Hz	6	1.0/AWG18	1.0/AWG18
GMV-ND28PLS/C-T	220-240V/50Hz 208-230V/60Hz	6	1.0/AWG18	1.0/AWG18
GMV-ND32PLS/C-T	220-240V/50Hz 208-230V/60Hz	6	1.0/AWG18	1.0/AWG18
GMV-ND36PLS/C-T	220-240V/50Hz 208-230V/60Hz	6	1.0/AWG18	1.0/AWG18
GMV-ND40PLS/C-T	220-240V/50Hz 208-230V/60Hz	6	1.0/AWG18	1.0/AWG18
GMV-ND45PLS/C-T	220-240V/50Hz 208-230V/60Hz	6	1.0/AWG18	1.0/AWG18
GMV-ND50PLS/C-T	220-240V/50Hz 208-230V/60Hz	6	1.0/AWG18	1.0/AWG18
GMV-ND56PLS/C-T	220-240V/50Hz 208-230V/60Hz	6	1.0/AWG18	1.0/AWG18
GMV-ND63PLS/C-T	220-240V/50Hz 208-230V/60Hz	6	1.0/AWG18	1.0/AWG18
GMV-ND71PLS/C-T	220-240V/50Hz 208-230V/60Hz	6	1.0/AWG18	1.0/AWG18
GMV-ND80PLS/C-T	220-240V/50Hz 208-230V/60Hz	6	1.0/AWG18	1.0/AWG18
GMV-ND90PLS/C-T	220-240V/50Hz 208-230V/60Hz	6	1.0/AWG18	1.0/AWG18
GMV-ND100PLS/C-T	220-240V/50Hz 208-230V/60Hz	6	1.0/AWG18	1.0/AWG18
GMV-ND112PLS/C-T	220-240V/50Hz 208-230V/60Hz	6	1.0/AWG18	1.0/AWG18
GMV-ND125PLS/C-T	220-240V/50Hz 208-230V/60Hz	6	1.0/AWG18	1.0/AWG18
GMV-ND140PLS/C-T	220-240V/50Hz 208-230V/60Hz	6	1.0/AWG18	1.0/AWG18

3.4 Installation of 4-way Cassette Type Unit

3.4.1 Outline and installation dimension

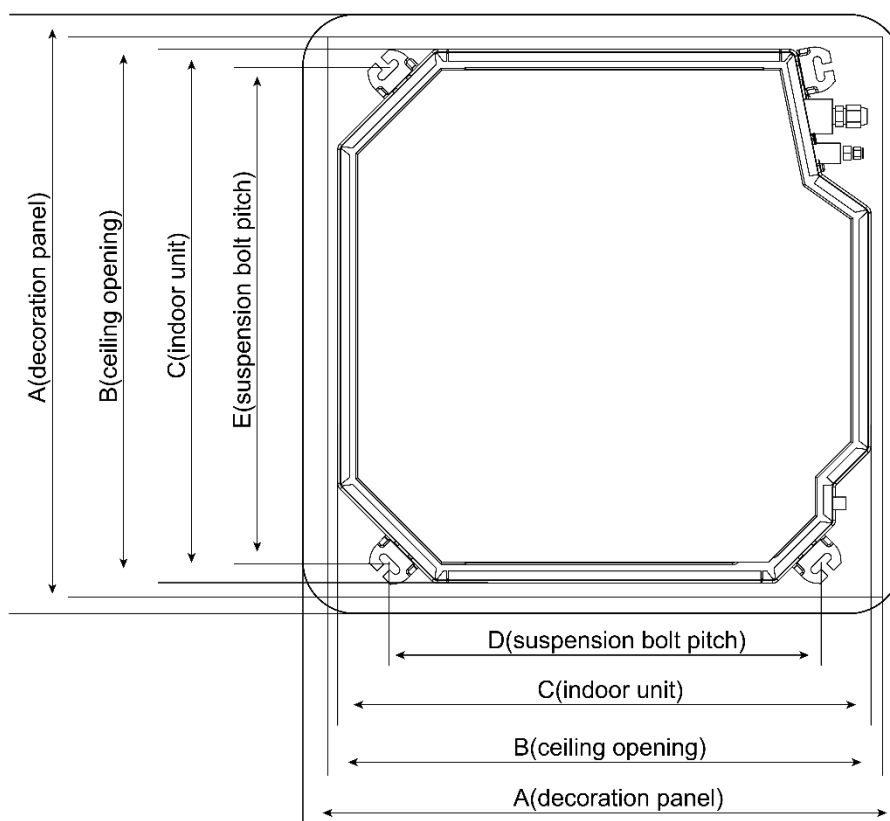

Below are dimensions of A, B, C etc. for different models:

Unit: mm

Model	A	B	C	D	E
GMV-ND28T/A-T	950	890	840	680	780
GMV-ND36T/A-T					
GMV-ND45T/A-T					
GMV-ND50T/A-T					
GMV-ND56T/A-T					
GMV-ND63T/A-T					
GMV-ND71T/A-T					
GMV-ND80T/A-T					
GMV-ND90T/A-T					
GMV-ND100T/A-T					
GMV-ND112T/A-T					
GMV-ND125T/A-T					
GMV-ND140T/A-T					
GMV-ND160T/A-T	1040	975	910	787	840

3.4.2 Installation space

Unit: mm

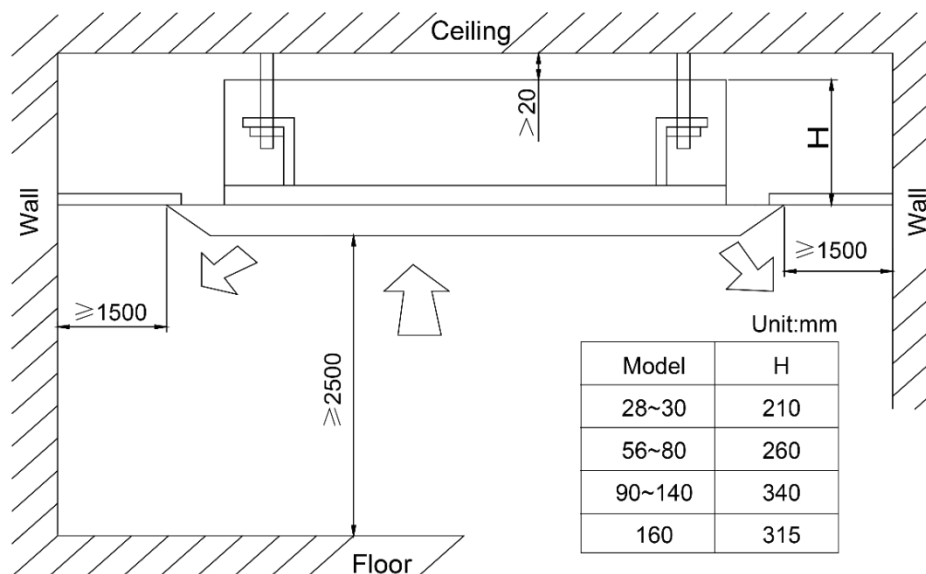

3.4.3 Installation notice

- ◆ The unit shall be installed by the professional personnel according to this installation instruction to ensure proper use.
- ◆ Please contact the local Gree appointed service center before installation. Any malfunction caused by the unit that is not installed by the Gree appointed service center would probably not be dealt with on time because of the inconvenience of the business contact.
- ◆ It should be guided under the professional personnel when the air conditioner unit is moved to other place.
- ◆ The unit shall be installed in accordance with national standards or local regulations.
- ◆ Only qualified personnel can carry out installation work, please contact with local dealer before installation.
- ◆ Make sure all the installation work completed before energizing.
- ◆ The appliances are not accessible to general public.

3.4.4 Selection of air switch and power cord

Model	Power Cord Size	Air Switch Capacity (A)	Minimum Sectional Area of Ground Wire (mm ² /AWG)	Minimum Sectional Area of Power Cord (mm ² /AWG)
GMV-ND28T/A-T	220-240V/50Hz 208-230V/60Hz	6	1.0/AWG18	1.0/AWG18
GMV-ND36T/A-T	220-240V/50Hz 208-230V/60Hz	6	1.0/AWG18	1.0/AWG18
GMV-ND45T/A-T	220-240V/50Hz 208-230V/60Hz	6	1.0/AWG18	1.0/AWG18
GMV-ND50T/A-T	220-240V/50Hz 208-230V/60Hz	6	1.0/AWG18	1.0/AWG18
GMV-ND56T/A-T	220-240V/50Hz 208-230V/60Hz	6	1.0/AWG18	1.0/AWG18
GMV-ND63T/A-T	220-240V/50Hz 208-230V/60Hz	6	1.0/AWG18	1.0/AWG18
GMV-ND71T/A-T	220-240V/50Hz 208-230V/60Hz	6	1.0/AWG18	1.0/AWG18

Model	Power Cord Size	Air Switch Capacity (A)	Minimum Sectional Area of Ground Wire (mm ² /AWG)	Minimum Sectional Area of Power Cord (mm ² /AWG)
GMV-ND80T/A-T	220-240V/50Hz 208-230V/60Hz	6	1.0/AWG18	1.0/AWG18
GMV-ND90T/A-T	220-240V/50Hz 208-230V/60Hz	6	1.0/AWG18	1.0/AWG18
GMV-ND100T/A-T	220-240V/50Hz 208-230V/60Hz	6	1.0/AWG18	1.0/AWG18
GMV-ND112T/A-T	220-240V/50Hz 208-230V/60Hz	6	1.0/AWG18	1.0/AWG18
GMV-ND125T/A-T	220-240V/50Hz 208-230V/60Hz	6	1.0/AWG18	1.0/AWG18
GMV-ND140T/A-T	220-240V/50Hz 208-230V/60Hz	6	1.0/AWG18	1.0/AWG18
GMV-ND160T/A-T	220-240V/50Hz 208-230V/60Hz	6	1.0/AWG18	1.0/AWG18

3.5 Installation of Compact 4-way Cassette Type Unit

3.5.1 Outline and installation dimension

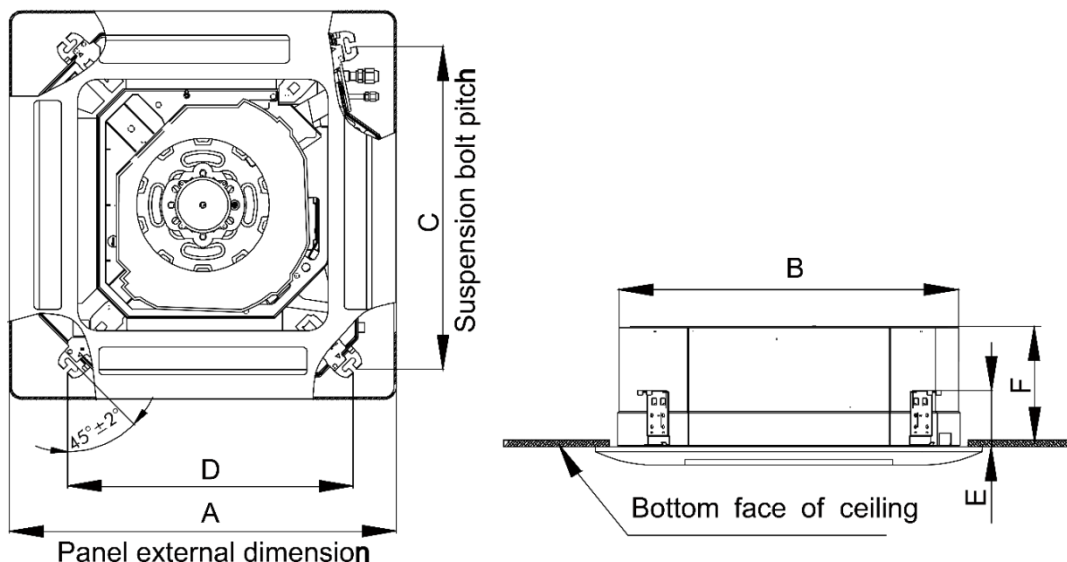

Below are dimensions of A, B, C etc. for different models:

Unit: mm

Model	A	B	C	D	E	F	Drainage Pipe(Outer Diameter×wall thickness)	Outer Diameter of Connection Pipe	
								Liquid pipe	Gas pipe
GMV-ND22T/B-T	670	596	600	571	145	240	Φ25×2.5	6.35	9.52
GMV-ND28T/B-T								6.35	9.52
GMV-ND36T/B-T								6.35	12.7
GMV-ND45T/B-T								6.35	12.7
GMV-ND50T/B-T								6.35	12.7
GMV-ND56T/B-T								9.52	15.9

3.5.2 Installation space

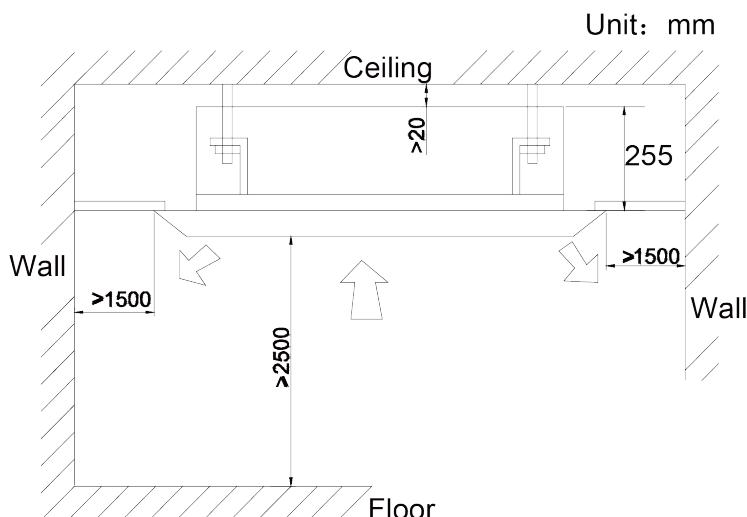

3.5.3 Installation notice

- ◆ The unit shall be installed by the professional personnel according to this installation instruction to ensure proper use.
- ◆ Please contact the local Gree appointed service center before installation. Any malfunction caused by the unit that is not installed by the Gree appointed service center would probably not be dealt with on time because of the inconvenience of the business contact.
- ◆ It should be guided under the professional personnel when the air conditioner unit is moved to other place.
- ◆ The unit shall be installed in accordance with national standards or local regulations.
- ◆ Only qualified personnel can carry out installation work, please contact with local dealer before installation.
- ◆ Make sure all the installation work completed before energizing.

3.5.4 Selection of air switch and power cord

Model	Power Cord Size	Air Switch Capacity (A)	Minimum Sectional Area of Ground Wire (mm ² /AWG)	Minimum Sectional Area of Power Cord (mm ² /AWG)
GMV-ND22T/B-T	220-240V/50Hz 208-230V/60Hz	6	1.0/AWG18	1.0/AWG18
GMV-ND28T/B-T	220-240V/50Hz 208-230V/60Hz	6	1.0/AWG18	1.0/AWG18
GMV-ND36T/B-T	220-240V/50Hz 208-230V/60Hz	6	1.0/AWG18	1.0/AWG18
GMV-ND45T/B-T	220-240V/50Hz 208-230V/60Hz	6	1.0/AWG18	1.0/AWG18
GMV-ND50T/B-T	220-240V/50Hz 208-230V/60Hz	6	1.0/AWG18	1.0/AWG18
GMV-ND56T/B-T	220-240V/50Hz 208-230V/60Hz	6	1.0/AWG18	1.0/AWG18

3.6 Installation of 360° Air Discharge Compact Cassette Type Unit

3.6.1 Outline and installation dimension

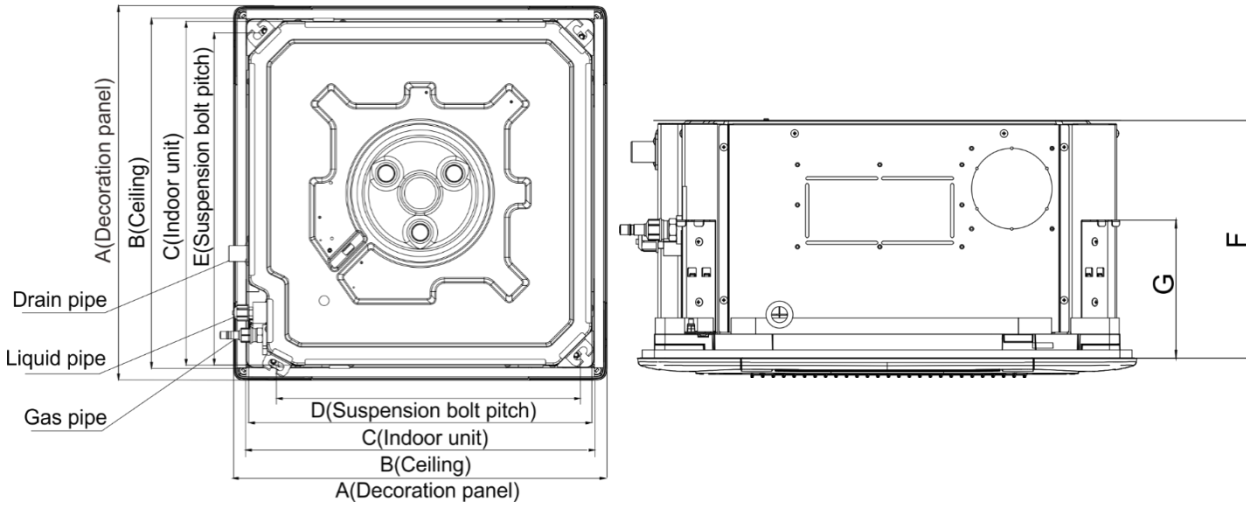

Model	A (mm)	B (mm)	C (mm)	D (mm)	E (mm)	F (mm)	Drainage Pipe(Outer Diameter× wall thickness) (mm)	Outer Diameter of Connection Pipe(mm)	
								Liquid pipe	Gas pipe
GMV-ND15T/E-T	620	580	570	505	550	295	Φ25×2.5	6.35	9.52
GMV-ND18T/E-T								6.35	9.52
GMV-ND22T/E-T								6.35	9.52
GMV-ND28T/E-T								6.35	9.52
GMV-ND36T/E-T								6.35	12.7
GMV-ND45T/E-T								6.35	12.7
GMV-ND50T/E-T								6.35	12.7
GMV-ND56T/E-T								9.52	15.9

3.6.2 Installation space

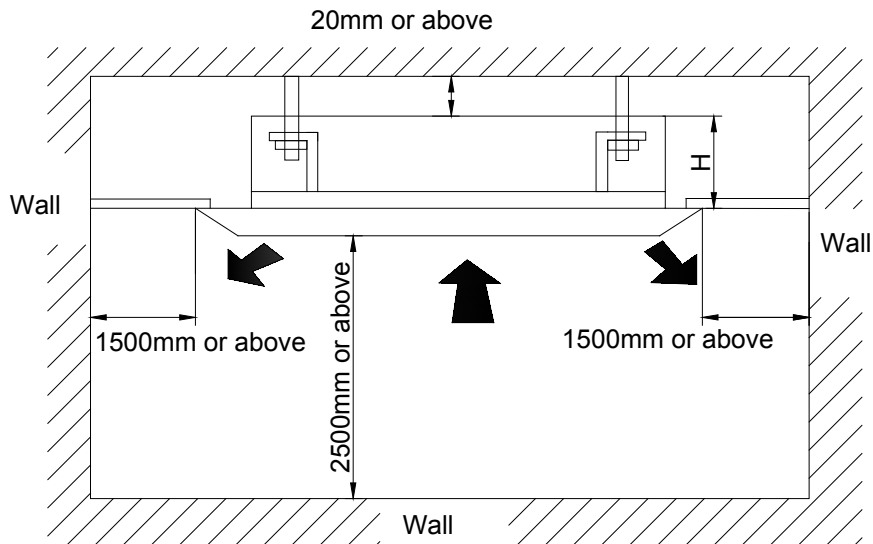

Model	H(mm)
GMV-ND15T/E-T	295
GMV-ND18T/E-T	295
GMV-ND22T/E-T	295
GMV-ND28T/E-T	295

Model	H(mm)
GMV-ND36T/E-T	295
GMV-ND45T/E-T	295
GMV-ND50T/E-T	295
GMV-ND56T/E-T	295

3.6.3 Installation notice

- ◆ The unit shall be installed by the professional personnel according to this installation instruction to ensure proper use.
- ◆ Please contact the local Gree appointed service center before installation. Any malfunction caused by the unit that is not installed by the Gree appointed service center would probably not be dealt with on time because of the inconvenience of the business contact.
- ◆ It should be guided under the professional personnel when the air conditioner unit is moved to other place.
- ◆ The unit shall be installed in accordance with national standards or local regulations.
- ◆ Only qualified personnel can carry out installation work, please contact with local dealer before installation.
- ◆ Make sure all the installation work completed before energizing.

3.6.4 Selection of air switch and power cord

Model	Power Cord Size	Air Switch Capacity (A)	Minimum Sectional Area of Ground Wire (mm ² /AWG)	Minimum Sectional Area of Power Cord (mm ² /AWG)
GMV-ND15T/E-T	220-240V/50Hz 208-230V/60Hz	6	1.0/AWG18	1.0/AWG18
GMV-ND18T/E-T	220-240V/50Hz 208-230V/60Hz	6	1.0/AWG18	1.0/AWG18
GMV-ND22T/E-T	220-240V/50Hz 208-230V/60Hz	6	1.0/AWG18	1.0/AWG18
GMV-ND28T/E-T	220-240V/50Hz 208-230V/60Hz	6	1.0/AWG18	1.0/AWG18
GMV-ND36T/E-T	220-240V/50Hz 208-230V/60Hz	6	1.0/AWG18	1.0/AWG18
GMV-ND45T/E-T	220-240V/50Hz 208-230V/60Hz	6	1.0/AWG18	1.0/AWG18
GMV-ND50T/E-T	220-240V/50Hz 208-230V/60Hz	6	1.0/AWG18	1.0/AWG18
GMV-ND56T/E-T	220-240V/50Hz 208-230V/60Hz	6	1.0/AWG18	1.0/AWG18

3.7 Installation of Compact 2-way Cassette Type Unit

3.7.1 Outline and installation dimension

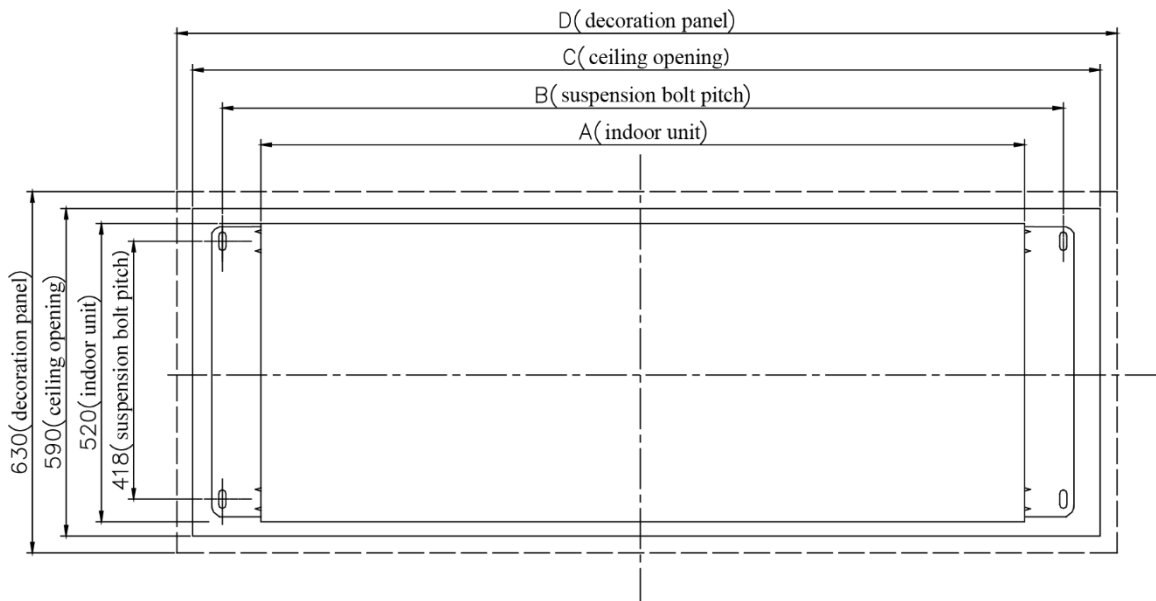

Below are dimensions of A, B, C etc. for different models:

Unit: mm

Model	Indoor unit(A)	Suspension bolt pitch(B)	Ceiling opening(C)	Decoration panel(D)	Outer diameter of connection pipe	
					Liquid pipe	Gas pipe
GMV-ND28TS/A-T	1200	1252	1386	1416	6.35	9.52
GMV-ND36TS/A-T GMV-ND45TS/A-T GMV-ND50TS/A-T	1200	1252	1386	1416	6.35	12.7
GMV-ND56TS/A-T GMV-ND63TS/A-T GMV-ND71TS/A-T	1200	1252	1386	1416	9.52	15.9

3.7.2 Installation space

Unit: mm

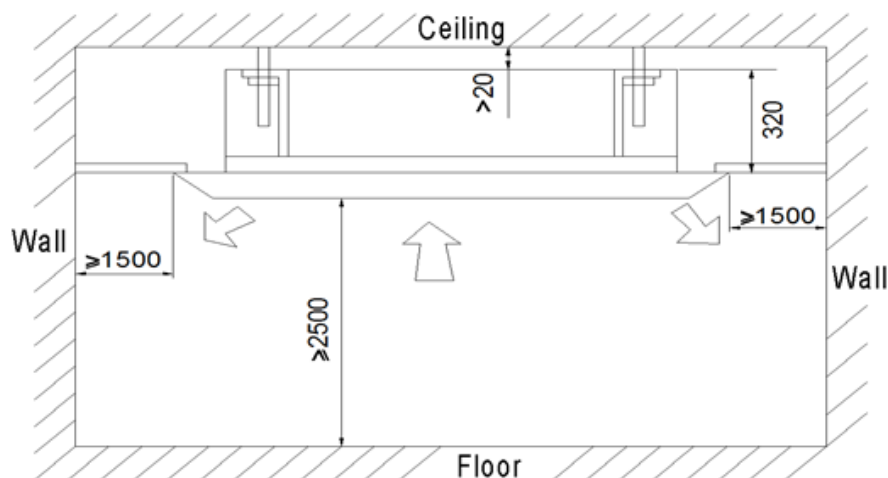

3.7.3 Installation notice

- ◆ The unit shall be installed by the professional personnel according to this installation instruction to ensure proper use.
- ◆ Please contact the local Gree appointed service center before installation. Any malfunction caused by the unit that is not installed by the Gree appointed service center would probably not be dealt with on time because of the inconvenience of the business contact.
- ◆ It should be guided under the professional personnel when the air conditioner unit is moved to other place.
- ◆ The unit shall be installed in accordance with national standards or local regulations.
- ◆ Only qualified personnel can carry out installation work, please contact with local dealer before installation.
- ◆ Make sure all the installation work completed before energizing.

3.7.4 Selection of air switch and power cord

Model	Power Cord Size	Air Switch Capacity(A)	Minimum Sectional Area of Ground Wire (mm ² /AWG)	Minimum Sectional Area of Power Cord (mm ² /AWG)
GMV-ND28TS/A-T	220-240V/50Hz 208-230V/60Hz	6	1.0/AWG18	1.0/AWG18
GMV-ND36TS/A-T	220-240V/50Hz 208-230V/60Hz	6	1.0/AWG18	1.0/AWG18
GMV-ND45TS/A-T	220-240V/50Hz 208-230V/60Hz	6	1.0/AWG18	1.0/AWG18
GMV-ND50TS/A-T	220-240V/50Hz 208-230V/60Hz	6	1.0/AWG18	1.0/AWG18
GMV-ND56TS/A-T	220-240V/50Hz 208-230V/60Hz	6	1.0/AWG18	1.0/AWG18
GMV-ND63TS/A-T	220-240V/50Hz 208-230V/60Hz	6	1.0/AWG18	1.0/AWG18
GMV-ND71TS/A-T	220-240V/50Hz 208-230V/60Hz	6	1.0/AWG18	1.0/AWG18

3.8 Installation of Compact 1-way Cassette Type Unit

3.8.1 Outline and installation dimension

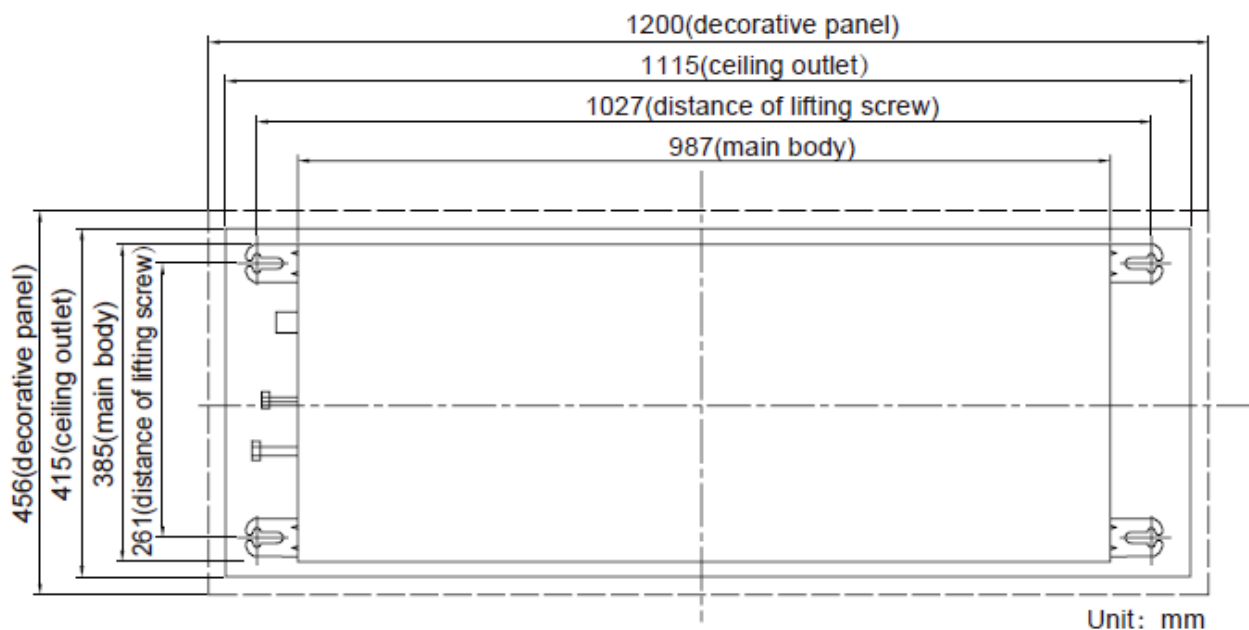

3.8.2 Installation space

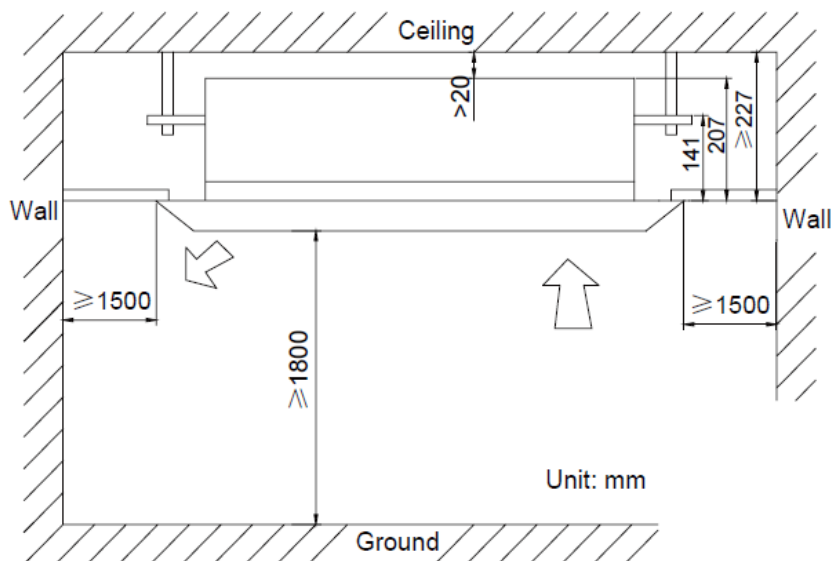

3.8.3 Installation notice

- ◆ The unit shall be installed by the professional personnel according to this installation instruction to ensure proper use.
- ◆ Please contact the local Gree appointed service center before installation. Any malfunction caused by the unit that is not installed by the Gree appointed service center would probably not be dealt with on time because of the inconvenience of the business contact.
- ◆ It should be guided under the professional personnel when the air conditioner unit is moved to other place.
- ◆ The unit shall be installed in accordance with national standards or local regulations.
- ◆ Only qualified personnel can carry out installation work, please contact with local dealer before

installation.

- ◆ Make sure all the installation work completed before energizing.

3.8.4 Selection of air switch and power cord

Model	Power Cord Size	Air Switch Capacity (A)	Minimum Sectional Area of Ground Wire (mm ² /AWG)	Minimum Sectional Area of Power Cord (mm ² /AWG)
GMV-ND22TD/A-T	220-240V/50Hz 208-230V/60Hz	6	1.0/AWG18	1.0/AWG18
GMV-ND28TD/A-T	220-240V/50Hz 208-230V/60Hz	6	1.0/AWG18	1.0/AWG18
GMV-ND36TD/A-T	220-240V/50Hz 208-230V/60Hz	6	1.0/AWG18	1.0/AWG18
GMV-ND45TD/A-T	220-240V/50Hz 208-230V/60Hz	6	1.0/AWG18	1.0/AWG18
GMV-ND50TD/A-T	220-240V/50Hz 208-230V/60Hz	6	1.0/AWG18	1.0/AWG18
GMV-ND56TD/A-T	220-240V/50Hz 208-230V/60Hz	6	1.0/AWG18	1.0/AWG18

3.9 Installation of Floor Ceiling Type Unit

3.9.1 Outline and installation dimension

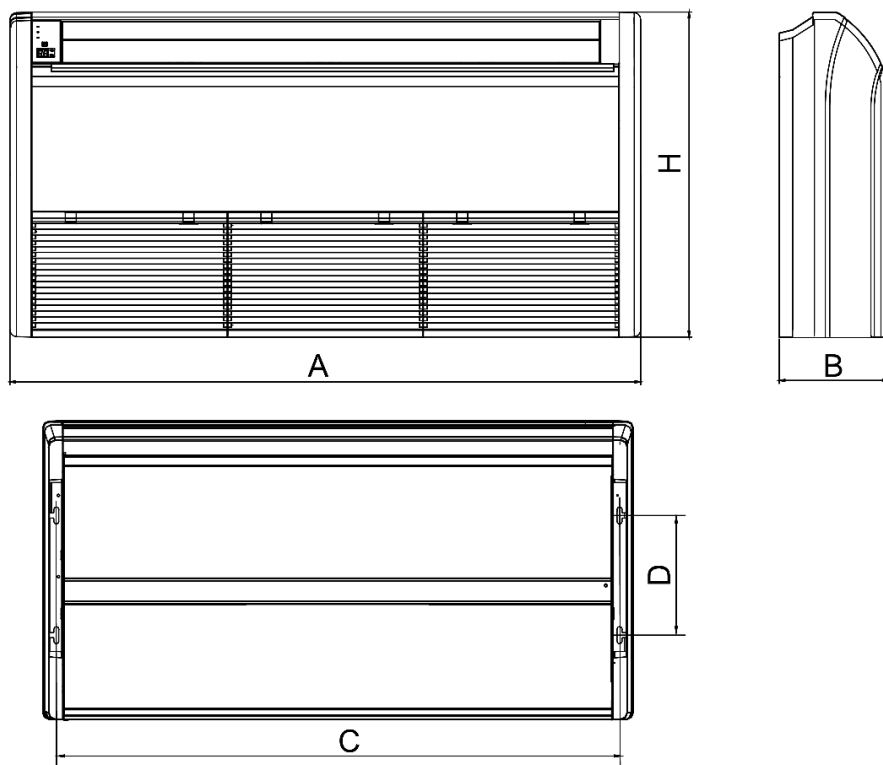

Below are dimensions of A, B, C, etc. for different models:

Unit: mm

Model	A	B	C	D	H	Drainage pipe(Outer Diameter × wall thickness)	Outer diameter of connection pipe	
							Liquid pipe	Gas pipe
GMV-ND28ZD/A-T	1220	225	1158	280	700	Φ17×1.75	6.35	9.52
GMV-ND36ZD/A-T							6.35	12.7
GMV-ND50ZD/A-T							9.52	15.9
GMV-ND63ZD/A-T	1420	245	1354	280	700		9.52	15.9
GMV-ND71ZD/A-T							9.52	15.9
GMV-ND90ZD/A-T							9.52	15.9
GMV-ND112ZD/A-T	1700	245	1634	280	700	9.52	15.9	
GMV-ND125ZD/A-T						9.52	15.9	
GMV-ND140ZD/A-T						9.52	15.9	
GMV-ND160ZD/A-T						9.52	19.05	

3.9.2 Installation space

Unit: mm

◆ Floor type

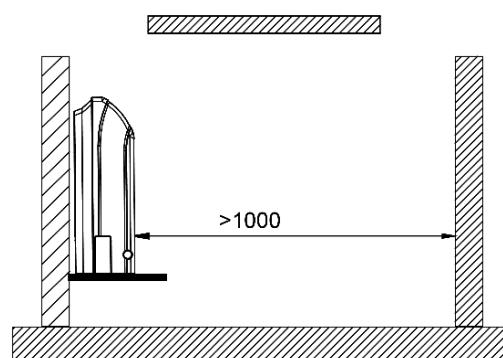
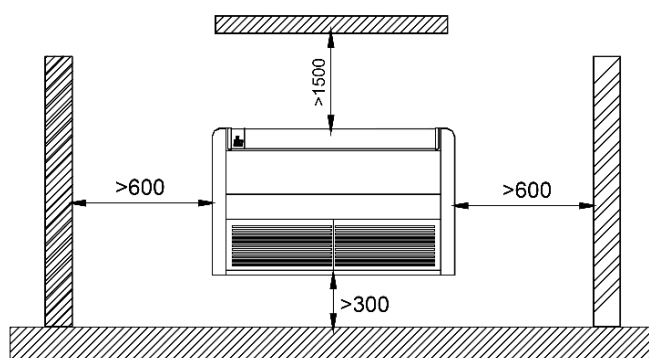

◆ Ceiling type

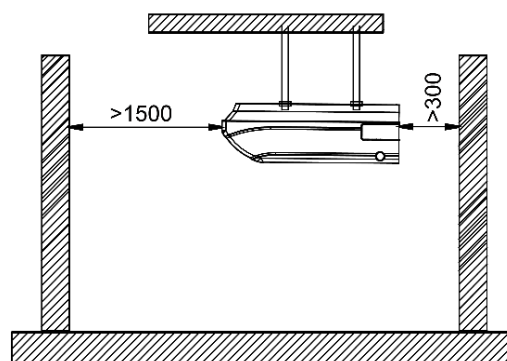
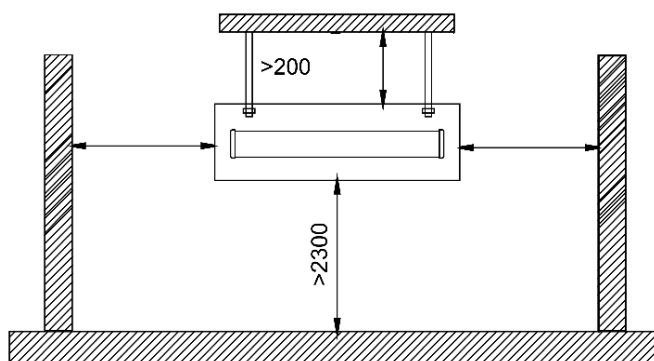

3.9.3 Installation notice

- ◆ The unit shall be installed by the professional personnel according to this installation instruction to ensure proper use.
- ◆ Please contact the local Gree appointed service center before installation. Any malfunction caused by the unit that is not installed by the Gree appointed service center would probably not be dealt with on time because of the inconvenience of the business contact.
- ◆ It should be guided under the professional personnel when the air conditioner unit is moved to other place.

- ◆ The unit shall be installed in accordance with national standards or local regulations.
- ◆ Only qualified personnel can carry out installation work, please contact with local dealer before installation.
- ◆ Make sure all the installation work completed before energizing.

3.9.4 Selection of air switch and power cord

Model	Power Cord Size	Air Switch capacity (A)	Minimum Sectional Area of Ground Wire (mm ² /AWG)	Minimum Sectional Area of Power Cord (mm ² /AWG)
GMV-ND28ZD/A-T	220-240V/50Hz 208-230V/60Hz	6	1.0/AWG18	1.0/AWG18
GMV-ND36ZD/A-T	220-240V/50Hz 208-230V/60Hz	6	1.0/AWG18	1.0/AWG18
GMV-ND50ZD/A-T	220-240V/50Hz 208-230V/60Hz	6	1.0/AWG18	1.0/AWG18
GMV-ND56ZD/A-T	220-240V/50Hz 208-230V/60Hz	6	1.0/AWG18	1.0/AWG18
GMV-ND63ZD/A-T	220-240V/50Hz 208-230V/60Hz	6	1.0/AWG18	1.0/AWG18
GMV-ND71ZD/A-T	220-240V/50Hz 208-230V/60Hz	6	1.0/AWG18	1.0/AWG18
GMV-ND90ZD/A-T	220-240V/50Hz 208-230V/60Hz	6	1.0/AWG18	1.0/AWG18
GMV-ND112ZD/A-T	220-240V/50Hz 208-230V/60Hz	6	1.0/AWG18	1.0/AWG18
GMV-ND125ZD/A-T	220-240V/50Hz 208-230V/60Hz	6	1.0/AWG18	1.0/AWG18
GMV-ND140ZD/A-T	220-240V/50Hz 208-230V/60Hz	6	1.0/AWG18	1.0/AWG18
GMV-ND160ZD/A-T	220-240V/50Hz 208-230V/60Hz	6	1.0/AWG18	1.0/AWG18

3.10 Installation of Fresh air Processing Unit

3.10.1 Outline and installation dimension

Unit: mm

GMV-NX140P/A(X1.2)-K

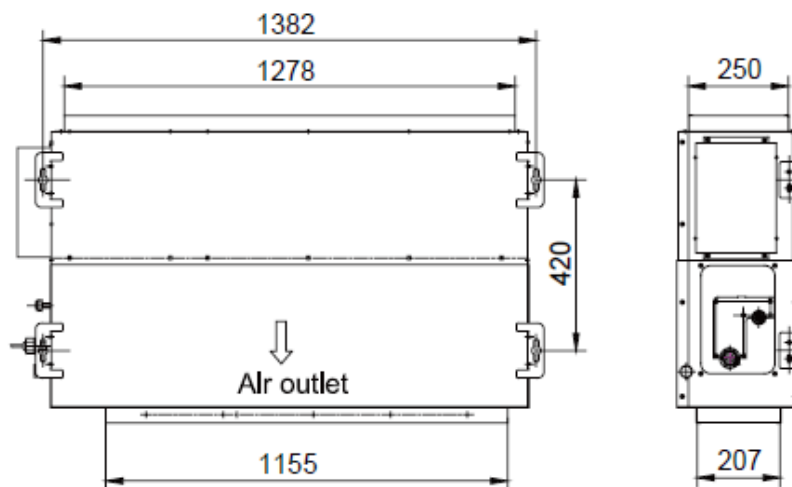

GMV-NX224P/A(X2.0)-M; GMV-NX280P/A(X2.5)-M; GMV-NX280P/A(X3.0)-M

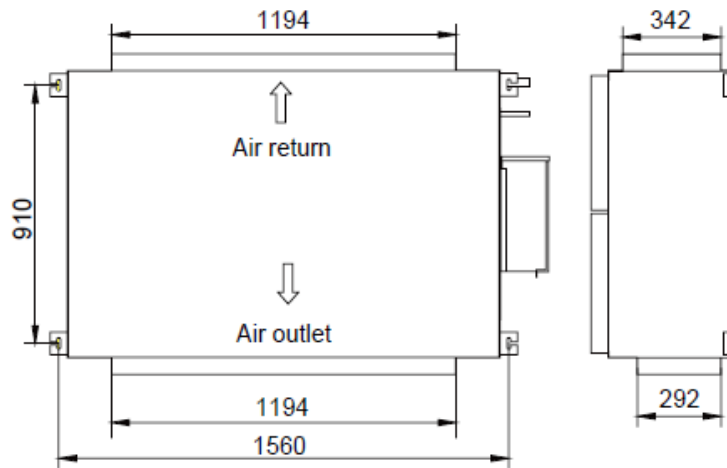

GMV-NX450P/A(X4.0)-M

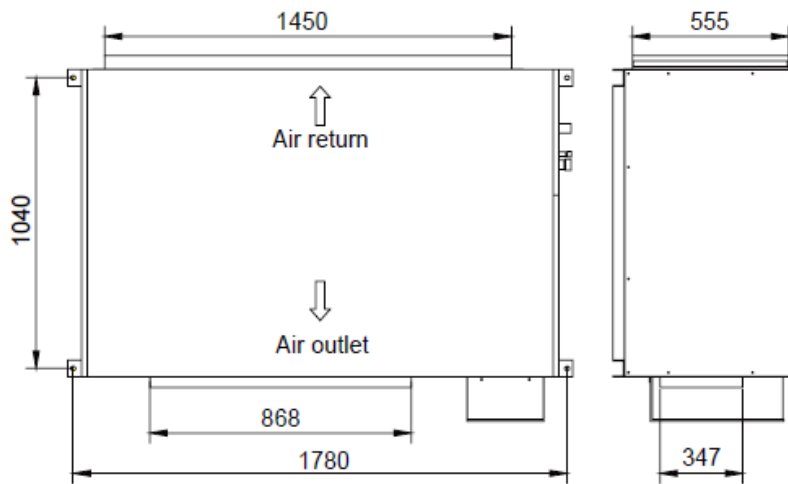

GMV-NDX125P/A-T, GMV-NDX140P/A-T

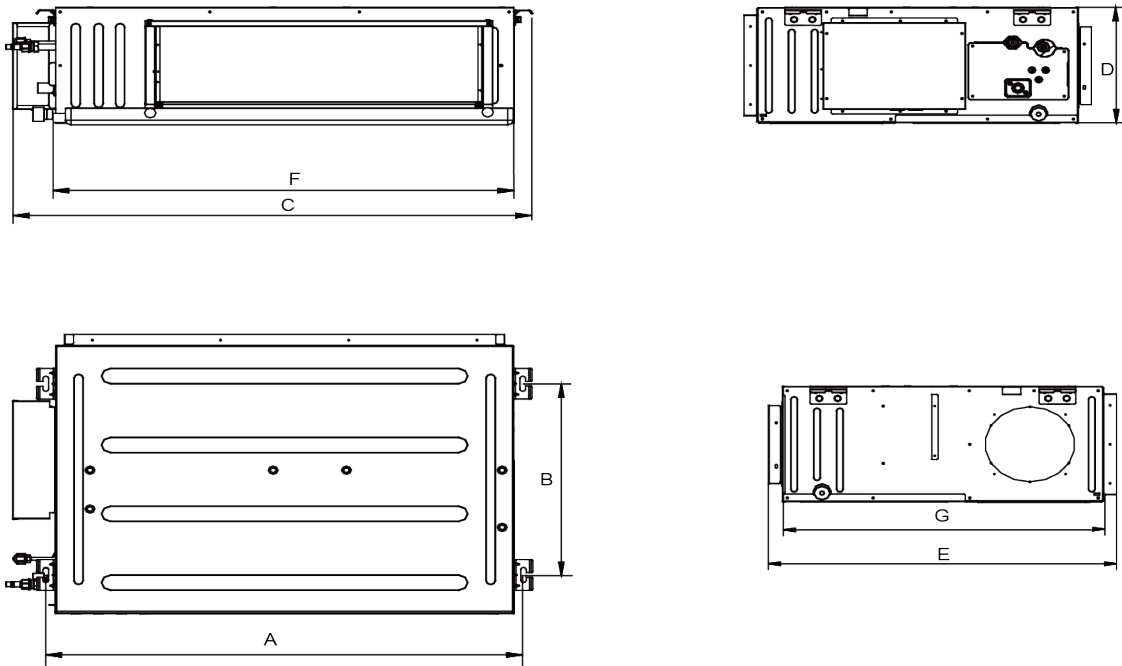

The table below lists the detailed dimensions.

Unit: mm

Model	A	B	C	D	E	F	G
GMV-NDX125P/A-T	1440	500	1530	300	754	1400	700
GMV-NDX140P/A-T	1440	500	1530	300	754	1400	700

GMV-NDX224P/A-T, GMV-NDX250P/A-T, GMV-NDX280P/A-T

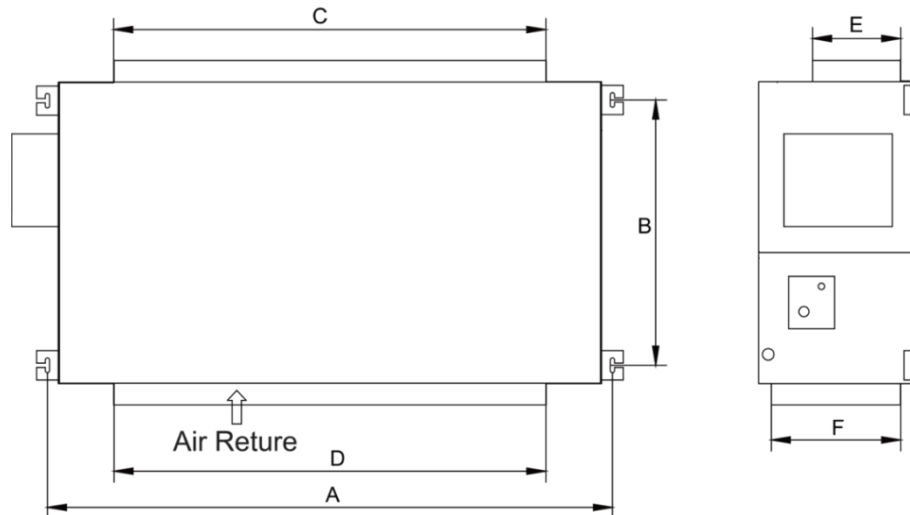

The table below lists the detailed dimensions.

Unit: mm

Model	A	B	C	D	E	F
GMV-NDX224P/A-T	1353	632	992	1150	192	327
GMV-NDX250P/A-T	1353	632	992	1150	192	327
GMV-NDX280P/A-T	1353	632	992	1150	192	327

3.10.2 Installation space

Unit: mm

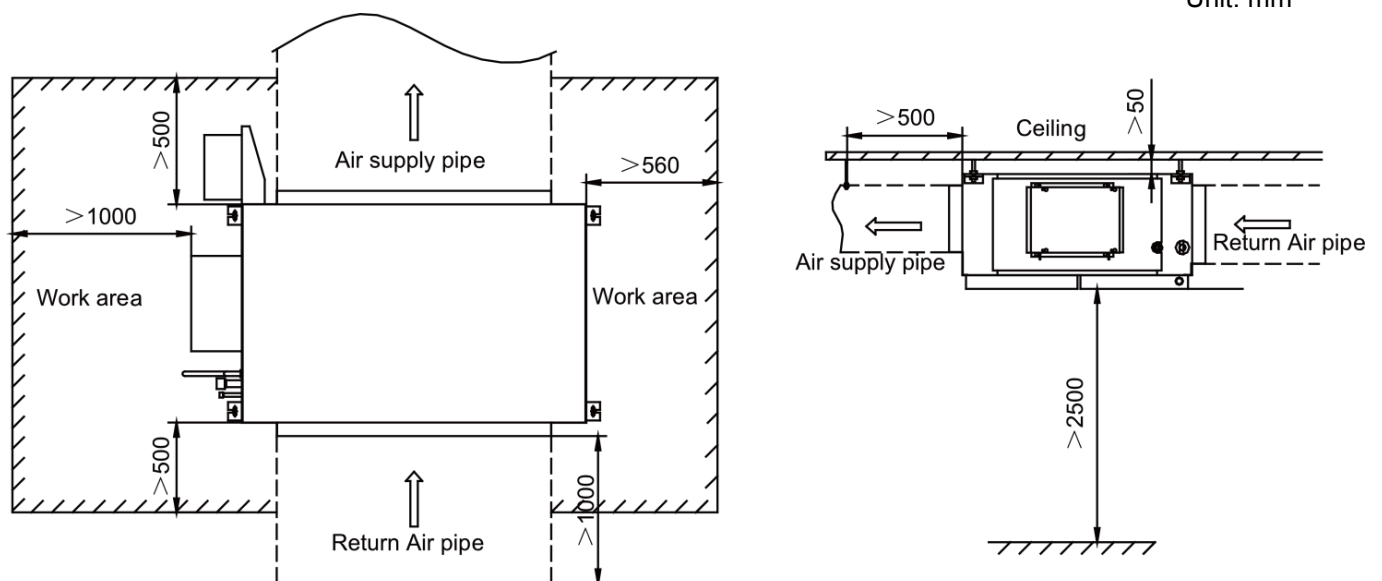

Notes:

- ① Installation of the unit must be in accordance with National Electric Codes and local safety regulations.

- ② Improper installation will affect unit's performance, so do not install the unit by yourself. Please contact local dealer to arrange professional technicians for the installation.
- ③ Do not connect power until all installation work is finished.

3.10.3 Installation notice

- ◆ The unit shall be installed by the professional personnel according to this installation instruction to ensure proper use.
- ◆ Please contact the local Gree appointed service center before installation. Any malfunction caused by the unit that is not installed by the Gree appointed service center would probably not be dealt with on time because of the inconvenience of the business contact.
- ◆ It should be guided under the professional personnel when the air conditioner unit is moved to other place.

3.10.4 Selection of air switch and power cord

Model	Power Cord Size	Air Switch capacity (A)	Minimum Sectional Area of Ground Wire (mm ² /AWG)	Minimum Sectional Area of Power Cord (mm ² /AWG)
GMV-NX140P/A(X1.2)-K	220-240V~50Hz	6	1.0/AWG18	1.0/AWG18
GMV-NX224P/A(X2.0)-M	380-415V 3N~50Hz	6	1.0/AWG18	1.0/AWG18
GMV-NX280P/A(X2.5)-M	380-415V 3N~50Hz	6	1.0/AWG18	1.0/AWG18
GMV-NX280P/A(X3.0)-M	380-415V 3N~50Hz	6	1.0/AWG18	1.0/AWG18
GMV-NX450P/A(X4.0)-M	380-415V 3N~50Hz	6	1.0/AWG18	1.0/AWG18
GMV-NDX125P/A-T	220-240V 1Ph 50Hz 208-230V 1Ph 60Hz	6	1.0/AWG18	1.0/AWG18
GMV-NDX140P/A-T	220-240V 1Ph 50Hz 208-230V 1Ph 60Hz	6	1.0/AWG18	1.0/AWG18
GMV-NDX224P/A-T	220-240V 1Ph 50Hz 208-230V 1Ph 60Hz	10	1.0/AWG18	1.0/AWG18
GMV-NDX250P/A-T	220-240V 1Ph 50Hz 208-230V 1Ph 60Hz	10	1.0/AWG18	1.0/AWG18
GMV-NDX280P/A-T	220-240V 1Ph 50Hz 208-230V 1Ph 60Hz	10	1.0/AWG18	1.0/AWG18

3.11 Installation of Slim Duct Type Unit

3.11.1 Outline and installation dimension

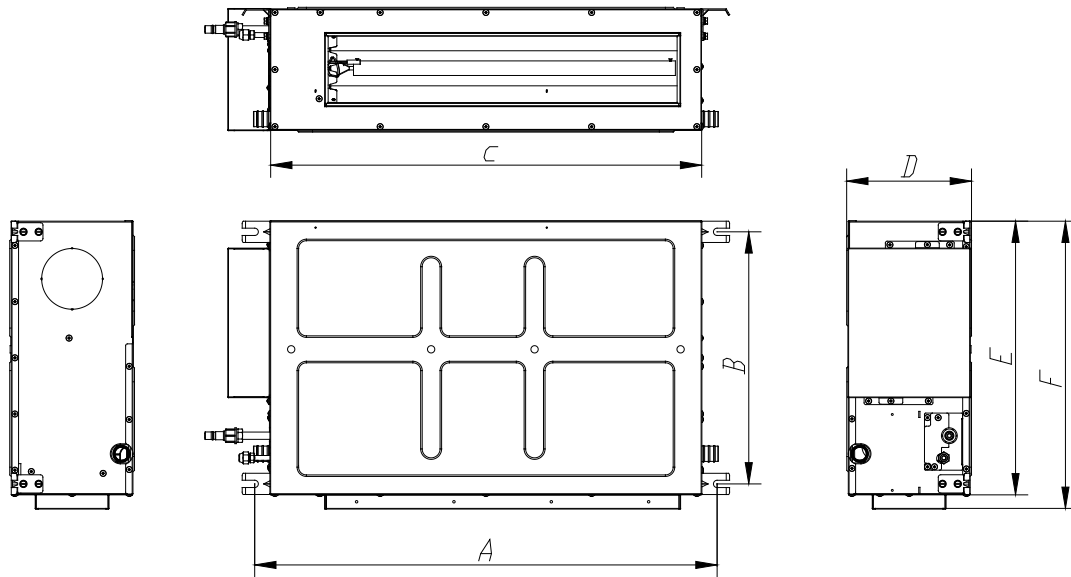

Unit: mm

Model	A	B	C	D	E	F
GMV-ND22~36PL/B-T GMV-ND22~36PLS/B1-T	760	415	710	200	450	475
GMV-ND40~63PL/B-T GMV-ND40~63PLS/B1-T	1060	415	1010	200	450	475
GMV-ND72PL/B-T GMV-ND40~63PLS/B1-T	1360	415	1310	200	450	475

3.11.2 Installation space

Unit: mm

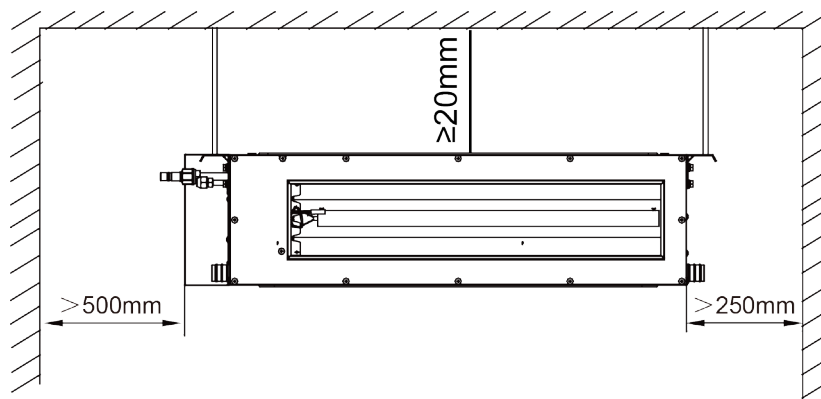

3.11.3 Installation notice

- ◆ The unit shall be installed by the professional personnel according to this installation instruction to ensure proper use.
- ◆ Please contact the local Gree appointed service center before installation. Any malfunction caused by the unit that is not installed by the Gree appointed service center would probably not be dealt with on time because of the inconvenience of the business contact.
- ◆ It should be guided under the professional personnel when the air conditioner unit is moved to other place.

- ◆ Installation of the unit must be in accordance with National Electric Codes and local regulations.
- ◆ Improper installation will affect unit's performance, so do not install the unit by yourself. Please contact local dealer to arrange professional technicians for the installation.
- ◆ Do not connect power until all installation work is finished.

3.11.4 Selection of air switch and power cord

Model	Power Cord Size	Air Switch capacity (A)	Minimum Sectional Area of Ground Wire (mm ² /AWG)	Minimum Sectional Area of Power Cord (mm ² /AWG)
GMV-ND22PL/B-T	220-240V~50Hz/ 208-230V~60Hz	6	1.0/AWG18	1.0/AWG18
GMV-ND25PL/B-T	220-240V~50Hz/ 208-230V~60Hz	6	1.0/AWG18	1.0/AWG18
GMV-ND28PL/B-T	220-240V~50Hz/ 208-230V~60Hz	6	1.0/AWG18	1.0/AWG18
GMV-ND32PL/B-T	220-240V~50Hz/ 208-230V~60Hz	6	1.0/AWG18	1.0/AWG18
GMV-ND36PL/B-T	220-240V~50Hz/ 208-230V~60Hz	6	1.0/AWG18	1.0/AWG18
GMV-ND40PL/B-T	220-240V~50Hz/ 208-230V~60Hz	6	1.0/AWG18	1.0/AWG18
GMV-ND45PL/B-T	220-240V~50Hz/ 208-230V~60Hz	6	1.0/AWG18	1.0/AWG18
GMV-ND50PL/B-T	220-240V~50Hz/ 208-230V~60Hz	6	1.0/AWG18	1.0/AWG18
GMV-ND56PL/B-T	220-240V~50Hz/ 208-230V~60Hz	6	1.0/AWG18	1.0/AWG18
GMV-ND63PL/B-T	220-240V~50Hz/ 208-230V~60Hz	6	1.0/AWG18	1.0/AWG18
GMV-ND72PL/B-T	220-240V~50Hz/ 208-230V~60Hz	6	1.0/AWG18	1.0/AWG18

3.12 Installation of Air Handler type Indoor Unit

3.12.1 Outline and installation dimension

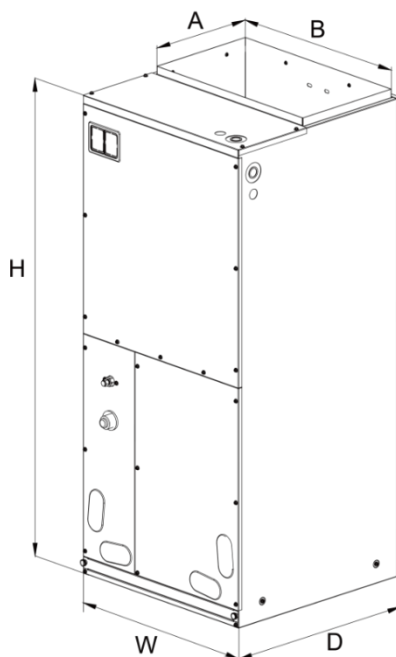

Below are dimensions of A, B, C, etc. for different models:

Unit: mm

Model	W	D	H	A	B
GMV-NR71A/A-D	460	540	1105	295	426
GMV-NR90A/A-D	460	540	1105	295	426
GMV-NR100A/A-D	540	540	1224	295	508
GMV-NR112A/A-D	540	540	1224	295	508
GMV-NR140A/A-D	630	540	1224	295	508

3.12.2 Installation notice

When installing the air handler, take consideration to minimize the length of refrigerant tubing as much as possible. Do not install the air handler in a location either above or below the condenser that violates the instructions provided with the condenser. Service clearance is to take precedence. Allow a minimum of 24" in front of the unit for service clearance. When installing in an area directly over a finished ceiling (such as an attic), an emergency drain pan is required directly under the unit. See local and state codes for requirements. When installing this unit in an area that may become wet, elevate the unit with a sturdy, non-porous material. In installations that may lead to physical damage (i.e. a garage) it is advised to install a protective barrier to prevent such damage.

This air handler is designed for a complete supply and return ductwork system. Do not operate this product without all ductwork attached.

Based upon the actual conditions, if air handler is installed as type (A), the air handler should be concealed in a specific room or space and make sure the air handler is not accessible to the general public.

Based upon the actual conditions, if air handler is installed as type (B), make sure that there is enough space for care and maintenance and the height between the air handler and ground is above 2500mm. And the air handler is not accessible to the general public.

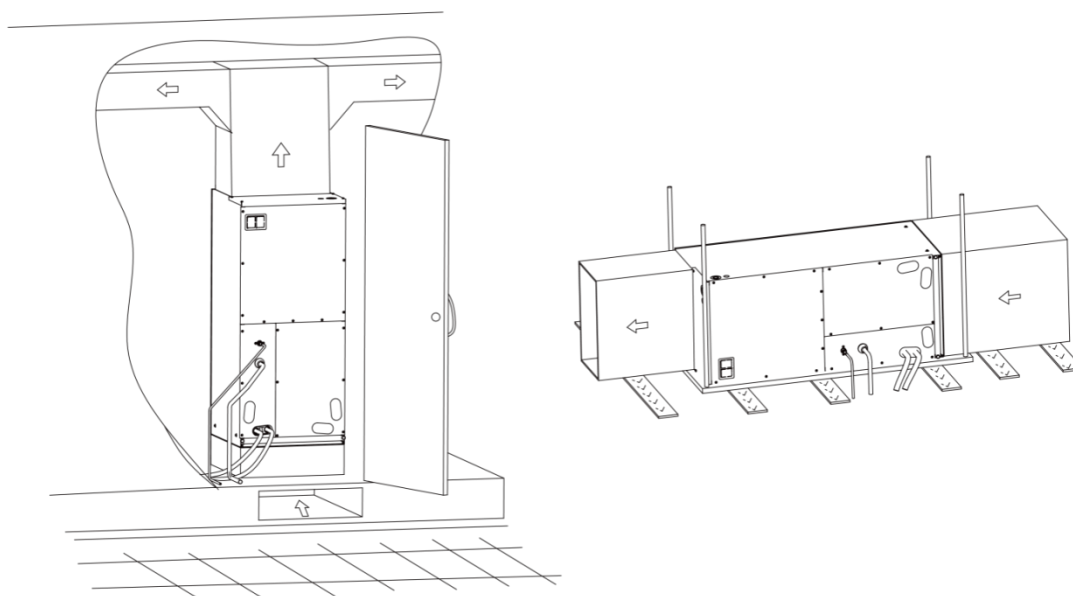

3.12.3 Selection of air switch and power cord

Model	Power Supply	Circuit Breaker Capacity (A)	Minimum Sectional Area of Ground Wire (mm ² /AWG)	Minimum Sectional Area of Power Cord (mm ² /AWG)
GMV-NR71A/A-D	208-230V~60Hz	6	1.0/AWG18	1.0/AWG18
GMV-NR90A/A-D	208-230V~60Hz	6	1.0/AWG18	1.0/AWG18
GMV-NR100A/A-D	208-230V~60Hz	6	1.0/AWG18	1.0/AWG18
GMV-NR112A/A-D	208-230V~60Hz	6	1.0/AWG18	1.0/AWG18
GMV-NR140A/A-D	208-230V~60Hz	6	1.0/AWG18	1.0/AWG18

3.13 Installation of Wall-Mounted Unit

3.13.1 Outline and installation dimension

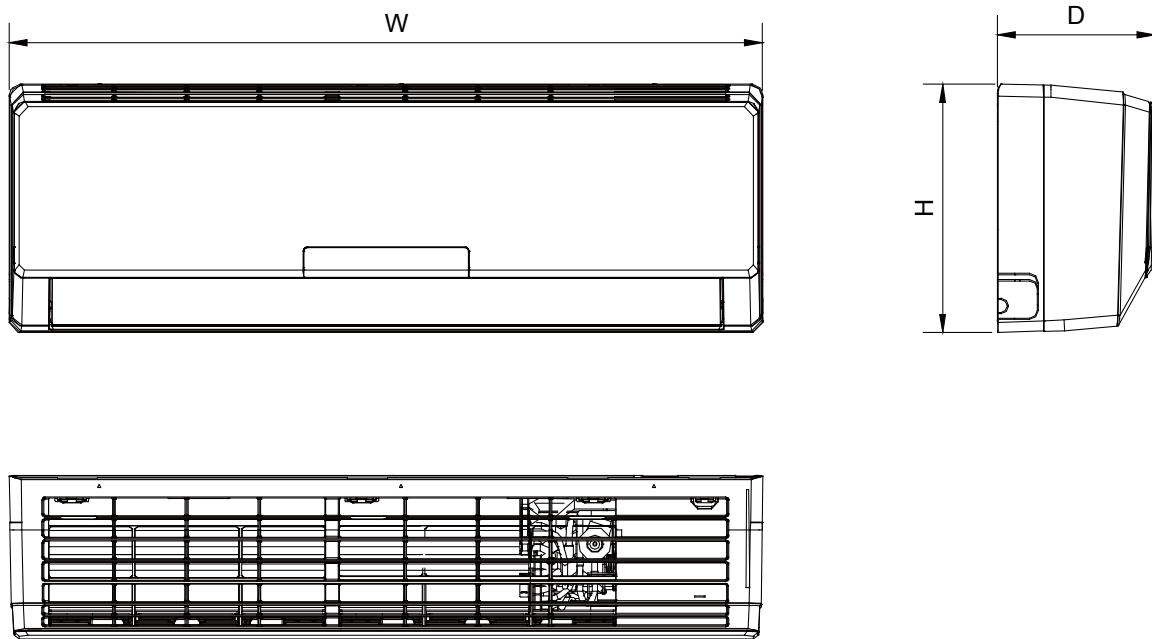

The table below lists the detailed dimensions.

Unit: mm

Model	W	H	D
GMV-N22G/A3A-K, GMV-N28G/A3A-K, GMV-N22G/A2A-K, GMV-N28G/A2A-K, GMV-N22G/A4A-K, GMV-N28G/A4A-K, GMV-N22G/A8A-K, GMV-N28G/A8A-K, GMV-N22G/C9A-K, GMV-N28G/C9A-K, GMV-N22G/E3A-K, GMV-N28G/E3A-K, GMV-N22G/B3A-K, GMV-N28G/B3A-K, GMV-N22G/A3A-D, GMV-N28G/A3A-D, GMV-N22G/A2A-D, GMV-N28G/A2A-D, GMV-N22G/A4A-D, GMV-N28G/A4A-D, GMV-N22G/A8A-D, GMV-N28G/A8A-D, GMV-N22G/C9A-D, GMV-N28G/C9A-D, GMV-N22G/E3A-D, GMV-N28G/E3A-D, GMV-N22G/B3A-D, GMV-N28G/B3A-D, GMV-ND22G/A3A-T, GMV-ND28G/A3A-T, GMV-ND22G/A8A-T, GMV-ND28G/A8A-T	843	275	180
GMV-N36G/A3A-K, GMV-N45G/A3A-K, GMV-N50G/A3A-K, GMV-N36G/A2A-K, GMV-N45G/A2A-K, GMV-N50G/A2A-K, GMV-N36G/A4A-K, GMV-N45G/A4A-K, GMV-N50G/A4A-K, GMV-N36G/A8A-K, GMV-N45G/A8A-K, GMV-N50G/A8A-K, GMV-N36G/C9A-K, GMV-N45G/C9A-K, GMV-N50G/C9A-K, GMV-N36G/E3A-K, GMV-N45G/E3A-K, GMV-N50G/E3A-K, GMV-N36G/B3A-K, GMV-N45G/B3A-K, GMV-N50G/B3A-K, GMV-N36G/A3A-D, GMV-N45G/A3A-D, GMV-N50G/A3A-D, GMV-N36G/A2A-D, GMV-N45G/A2A-D, GMV-N50G/A2A-D, GMV-N36G/A4A-D, GMV-N45G/A4A-D, GMV-N50G/A4A-D, GMV-N36G/A8A-D, GMV-N45G/A8A-D, GMV-N50G/A8A-D, GMV-N36G/C9A-D, GMV-N45G/C9A-D, GMV-N50G/C9A-D, GMV-N36G/E3A-D, GMV-N45G/E3A-D, GMV-N50G/E3A-D, GMV-N36G/B3A-D, GMV-N45G/B3A-D, GMV-N50G/B3A-D, GMV-ND36G/A3A-T, GMV-ND45G/A3A-T, GMV-ND50G/A3A-T, GMV-ND36G/A8A-T, GMV-ND45G/A8A-T, GMV-ND50G/A8A-T	940	298	200

Model	W	H	D
GMV-N56G/A3A-K, GMV-N63G/A3A-K, GMV-N71G/A3A-K, GMV-N56G/A2A-K, GMV-N63G/A2A-K, GMV-N71G/A2A-K, GMV-N56G/A4A-K, GMV-N63G/A4A-K, GMV-N71G/A4A-K, GMV-N56G/A8A-K, GMV-N63G/A8A-K, GMV-N71G/A8A-K, GMV-N56G/C9A-K, GMV-N63G/C9A-K, GMV-N71G/C9A-K, GMV-N56G/E3A-K, GMV-N63G/E3A-K, GMV-N71G/E3A-K, GMV-N56G/B3A-K, GMV-N63G/B3A-K, GMV-N71G/B3A-K, GMV-N56G/A3A-D, GMV-N63G/A3A-D, GMV-N71G/A3A-D, GMV-N56G/A2A-D, GMV-N63G/A2A-D, GMV-N71G/A2A-D, GMV-N56G/A4A-D, GMV-N63G/A4A-D, GMV-N71G/A4A-D, GMV-N56G/A8A-D, GMV-N63G/A8A-D, GMV-N71G/A8A-D, GMV-N56G/C9A-D, GMV-N63G/C9A-D, GMV-N71G/C9A-D, GMV-N56G/E3A-D, GMV-N63G/E3A-D, GMV-N71G/E3A-D, GMV-N56G/B3A-D, GMV-N63G/B3A-D, GMV-N71G/B3A-D, GMV-ND56G/A3A-T, GMV-ND63G/A3A-T, GMV-ND71G/A3A-T, GMV-ND56G/A8A-T, GMV-ND63G/A8A-T, GMV-ND71G/A8A-T	1008	221	319
GMV-ND80G/A3A-T, GMV-ND90G/A3A-T, GMV-ND100G/A3A-T, GMV-ND80G/A8A-T, GMV-ND90G/A8A-T, GMV-ND100G/A8A-T	1350	326	258

Model	W	H	D
GMV-ND22G/B6B-T, GMV-ND28G/B6B-T, GMV-ND36G/B6B-T, GMV-ND15G/B4B-T, GMV-ND18G/B4B-T, GMV-ND22G/B4B-T, GMV-ND28G/B4B-T, GMV-ND36G/B4B-T, GMV-ND22G/C4B-T, GMV-ND28G/C4B-T, GMV-ND36G/C4B-T, GMV-ND22G/C2B-T, GMV-ND28G/C2B-T, GMV-ND36G/C2B-T, GMV-ND22G/D2B-T, GMV-ND28G/D2B-T, GMV-ND36G/D2B-T	845	289	209
GMV-ND45G/B6B-T, GMV-ND50G/B6B-T, GMV-ND45G/B4B-T, GMV-ND50G/B4B-T, GMV-ND45G/C4B-T, GMV-ND50G/C4B-T, GMV-ND45G/C2B-T, GMV-ND50G/C2B-T, GMV-ND45G/D2B-T, GMV-ND50G/D2B-T	970	300	224
GMV-ND56G/B6B-T, GMV-ND63G/B6B-T, GMV-ND71G/B6B-T, GMV-ND56G/B4B-T, GMV-ND63G/B4B-T, GMV-ND71G/B4B-T, GMV-ND56G/C2B-T, GMV-ND63G/C2B-T, GMV-ND71G/C2B-T, GMV-ND56G/C4B-T, GMV-ND63G/C4B-T, GMV-ND71G/C4B-T, GMV-ND56G/D2B-T, GMV-ND63G/D2B-T, GMV-ND71G/D2B-T	1078	325	246
GMV-ND80G/B4B-T, GMV-ND90G/B4B-T, GMV-ND100G/B4B-T	1350	326	258

3.13.2 Installation space

Unit: mm

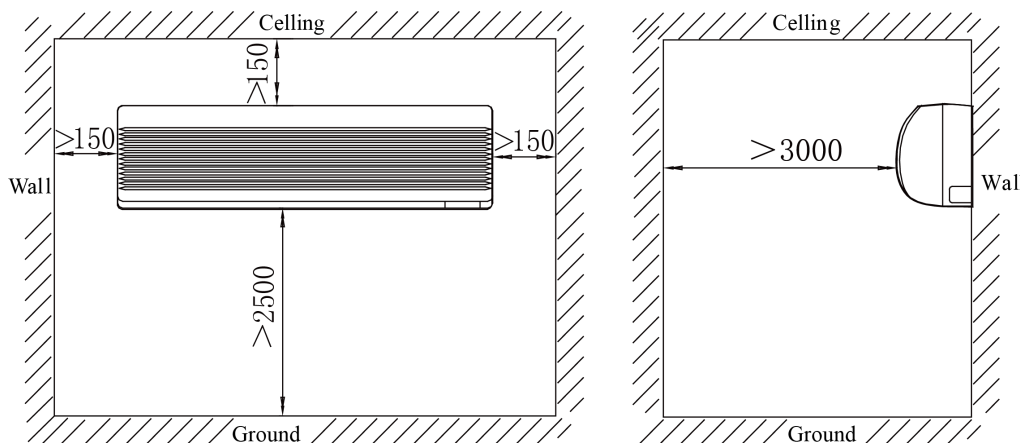

3.13.3 Installation notice

Connect the ends of the connection pipe with two leading pipes, and then tighten the joint nuts tightly.

Connect the connect pipe with the two relative leading pipe, tie the nut on tie –in of the connect pipe tightly.



Notes:

- ① Be careful in bending the connection pipes, or you would damage the pipes.
- ② If the tightening torque for the flare nut is too great, leakage would happen.

3.13.4 Selection of air switch and power cord

Model	Power Cord Size	Air Switch Capacity (A)	Minimum Sectional Area of Ground Wire (mm ² /AWG)	Minimum Sectional Area of Power Cord (mm ² /AWG)
GMV-N22G/A3A-K GMV-N22G/A2A-K GMV-N22G/A4A-K GMV-N22G/A8A-K GMV-N22G/C9A-K GMV-N22G/E3A-K GMV-N22G/B3A-K	220-240V ~ 50Hz	6	1.0/AWG18	1.0/AWG18
GMV-N28G/A3A-K GMV-N28G/A2A-K GMV-N28G/A4A-K GMV-N28G/A8A-K GMV-N28G/C9A-K GMV-N28G/E3A-K GMV-N28G/B3A-K	220-240V ~ 50Hz	6	1.0/AWG18	1.0/AWG18
GMV-N36G/A3A-K GMV-N36G/A2A-K GMV-N36G/A4A-K GMV-N36G/A8A-K GMV-N36G/C9A-K GMV-N36G/E3A-K GMV-N36G/B3A-K	220-240V ~ 50Hz	6	1.0/AWG18	1.0/AWG18
GMV-N45G/A3A-K GMV-N45G/A2A-K GMV-N45G/A4A-K GMV-N45G/A8A-K GMV-N45G/C9A-K GMV-N45G/E3A-K GMV-N45G/B3A-K	220-240V ~ 50Hz	6	1.0/AWG18	1.0/AWG18
GMV-N50G/A3A-K GMV-N50G/A2A-K GMV-N50G/A4A-K GMV-N50G/A8A-K GMV-N50G/C9A-K GMV-N50G/E3A-K GMV-N50G/B3A-K	220-240V ~ 50Hz	6	1.0/AWG18	1.0/AWG18
GMV-N56G/A3A-K GMV-N56G/A2A-K GMV-N56G/A4A-K GMV-N56G/A8A-K GMV-N56G/C9A-K GMV-N56G/E3A-K GMV-N56G/B3A-K	220-240V ~ 50Hz	6	1.0/AWG18	1.0/AWG18
GMV-N63G/A3A-K GMV-N63G/A2A-K GMV-N63G/A4A-K GMV-N63G/A8A-K GMV-N63G/C9A-K GMV-N63G/E3A-K GMV-N63G/B3A-K	220-240V ~ 50Hz	6	1.0/AWG18	1.0/AWG18

Model	Power Cord Size	Air Switch Capacity (A)	Minimum Sectional Area of Ground Wire (mm ² /AWG)	Minimum Sectional Area of Power Cord (mm ² /AWG)
GMV-N71G/A3A-K GMV-N71G/A2A-K GMV-N71G/A4A-K GMV-N71G/A8A-K GMV-N71G/C9A-K GMV-N71G/E3A-K GMV-N71G/B3A-K	220-240V ~ 50Hz	6	1.0/AWG18	1.0/AWG18
GMV-N22G/A3A-D GMV-N22G/A2A-D GMV-N22G/A4A-D GMV-N22G/A8A-D GMV-N22G/C9A-D GMV-N22G/E3A-D GMV-N22G/B3A-D	208~230V ~ 60Hz	6	1.0/AWG18	1.0/AWG18
GMV-N28G/A3A-D GMV-N28G/A2A-D GMV-N28G/A4A-D GMV-N28G/A8A-D GMV-N28G/C9A-D GMV-N28G/E3A-D GMV-N28G/B3A-D	208~230V ~ 60Hz	6	1.0/AWG18	1.0/AWG18
GMV-N36G/A3A-D GMV-N36G/A2A-D GMV-N36G/A4A-D GMV-N36G/A8A-D GMV-N36G/C9A-D GMV-N36G/E3A-D GMV-N36G/B3A-D	208~230V ~ 60Hz	6	1.0/AWG18	1.0/AWG18
GMV-N45G/A3A-D GMV-N45G/A2A-D GMV-N45G/A4A-D GMV-N45G/A8A-D GMV-N45G/C9A-D GMV-N45G/E3A-D GMV-N45G/B3A-D	208~230V ~ 60Hz	6	1.0/AWG18	1.0/AWG18
GMV-N50G/A3A-D GMV-N50G/A2A-D GMV-N50G/A4A-D GMV-N50G/A8A-D GMV-N50G/C9A-D GMV-N50G/E3A-D GMV-N50G/B3A-D	208~230V ~ 60Hz	6	1.0/AWG18	1.0/AWG18
GMV-N56G/A3A-D GMV-N56G/A2A-D GMV-N56G/A4A-D GMV-N56G/A8A-D GMV-N56G/C9A-D GMV-N56G/E3A-D GMV-N56G/B3A-D	208~230V ~ 60Hz	6	1.0/AWG18	1.0/AWG18
GMV-N63G/A3A-D GMV-N63G/A2A-D GMV-N63G/A4A-D GMV-N63G/A8A-D GMV-N63G/C9A-D GMV-N63G/E3A-D GMV-N63G/B3A-D	208~230V ~ 60Hz	6	1.0/AWG18	1.0/AWG18

Model	Power Cord Size	Air Switch Capacity (A)	Minimum Sectional Area of Ground Wire (mm ² /AWG)	Minimum Sectional Area of Power Cord (mm ² /AWG)
GMV-N71G/A3A-D GMV-N71G/A2A-D GMV-N71G/A4A-D GMV-N71G/A8A-D GMV-N71G/C9A-D GMV-N71G/E3A-D GMV-N71G/B3A-D	208~230V ~ 60Hz	6	1.0/AWG18	1.0/AWG18

Model	Power Cord Size	Air Switch Capacity (A)	Minimum Sectional Area of Ground Wire (mm ² /AWG)	Minimum Sectional Area of Power Cord (mm ² /AWG)
GMV-ND15G/B4B-T	220-240V~50Hz /208-230V~60Hz	6	1.0/AWG18	1.0/AWG18
GMV-ND18G/B4B-T	220-240V~50Hz /208-230V~60Hz	6	1.0/AWG18	1.0/AWG18
GMV-ND22G/A3A-T GMV-ND22G/A8A-T GMV-ND22G/B6B-T GMV-ND22G/B4B-T GMV-ND22G/C4B-T GMV-ND22G/C2B-T GMV-ND22G/D2B-T	220-240V~50Hz /208-230V~60Hz	6	1.0/AWG18	1.0/AWG18
GMV-ND28G/A3A-T GMV-ND28G/A8A-T GMV-ND28G/B6B-T GMV-ND28G/B4B-T GMV-ND28G/C4B-T GMV-ND28G/C2B-T GMV-ND28G/D2B-T	220-240V~50Hz /208-230V~60Hz	6	1.0/AWG18	1.0/AWG18
GMV-ND36G/A3A-T GMV-ND36G/A8A-T GMV-ND36G/B6B-T GMV-ND36G/B4B-T GMV-ND36G/C4B-T GMV-ND36G/C2B-T GMV-ND36G/D2B-T	220-240V~50Hz /208-230V~60Hz	6	1.0/AWG18	1.0/AWG18
GMV-ND45G/A3A-T GMV-ND45G/A8A-T GMV-ND45G/B6B-T GMV-ND45G/B4B-T GMV-ND45G/C4B-T GMV-ND45G/C2B-T GMV-ND45G/D2B-T	220-240V~50Hz /208-230V~60Hz	6	1.0/AWG18	1.0/AWG18
GMV-ND50G/A3A-T GMV-ND50G/A8A-T GMV-ND50G/B6B-T GMV-ND50G/B4B-T GMV-ND50G/C4B-T GMV-ND50G/C2B-T GMV-ND50G/D2B-T	220-240V~50Hz /208-230V~60Hz	6	1.0/AWG18	1.0/AWG18
GMV-ND56G/A3A-T GMV-ND56G/A8A-T GMV-ND56G/B6B-T GMV-ND56G/B4B-T GMV-ND56G/C4B-T GMV-ND56G/C2B-T GMV-ND56G/D2B-T	220-240V~50Hz /208-230V~60Hz	6	1.0/AWG18	1.0/AWG18

Model	Power Cord Size	Air Switch Capacity (A)	Minimum Sectional Area of Ground Wire (mm ² /AWG)	Minimum Sectional Area of Power Cord (mm ² /AWG)
GMV-ND63G/A3A-T GMV-ND63G/A8A-T GMV-ND63G/B6B-T GMV-ND63G/B4B-T GMV-ND63G/C4B-T GMV-ND63G/C2B-T GMV-ND63G/D2B-T	220-240V~50Hz /208-230V~60Hz	6	1.0/AWG18	1.0/AWG18
GMV-ND71G/A3A-T GMV-ND71G/A8A-T GMV-ND71G/B6B-T GMV-ND71G/B4B-T GMV-ND71G/C4B-T GMV-ND71G/C2B-T GMV-ND71G/D2B-T	220-240V~50Hz /208-230V~60Hz	6	1.0/AWG18	1.0/AWG18
GMV-ND80G/A3A-T GMV-ND80G/A8A-T GMV-ND80G/B4B-T	220-240V~50Hz /208-230V~60Hz	6	1.0/AWG18	1.0/AWG18
GMV-ND90G/A3A-T GMV-ND90G/A8A-T GMV-ND90G/B4B-T	220-240V~50Hz /208-230V~60Hz	6	1.0/AWG18	1.0/AWG18
GMV-ND100G/A3A-T GMV-ND100G/A8A-T GMV-ND100G/B4B-T	220-240V~50Hz /208-230V~60Hz	6	1.0/AWG18	1.0/AWG18

3.14 Console Type Indoor Unit

3.14.1 Outline and installation dimension

The table below lists the detailed dimensions.

Unit: mm

Model	W	H	D
GMV-ND22C/A-T GMV-ND28C/A-T GMV-ND36C/A-T GMV-ND45C/A-T GMV-ND50C/A-T	700	600	215

3.14.2 Installation space

Unit:mm

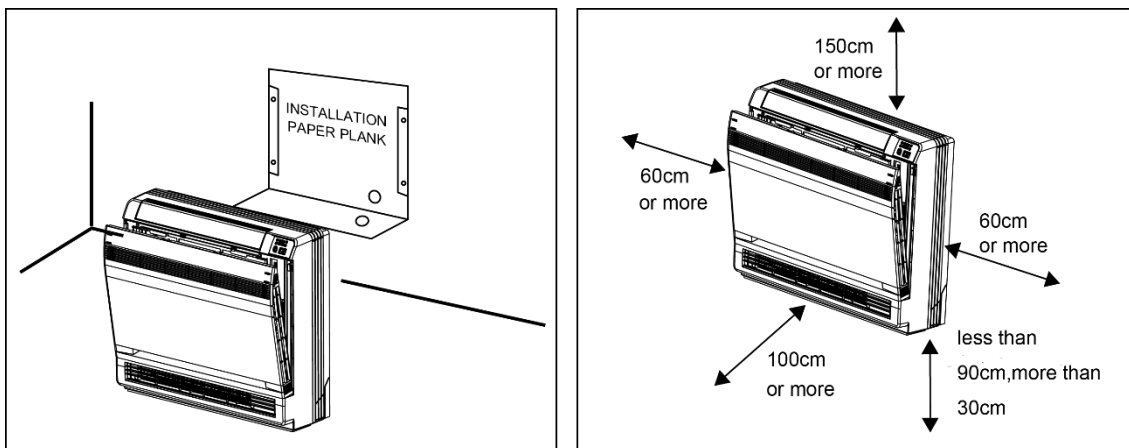

3.14.3 Installation notice

Connect the ends of the connection pipe with two leading pipes, and then tighten the joint nuts tightly.

Connect the connect pipe with the two relative leading pipe, tie the nut on tie –in of the connect pipe tightly.



Notes:

- ① Be careful in bending the connection pipes, or you would damage the pipes.
- ② If the tightening torque for the flare nut is too great, leakage would happen.

3.14.4 Selection of air switch and power cord

Model	Power Cord Size	Air Switch Capacity (A)	Minimum Sectional Area of Ground Wire (mm ² /AWG)	Minimum Sectional Area of Power Cord (mm ² /AWG)
GMV-ND22C/A-T, GMV-ND28C/A-T GMV-ND36C/A-T, GMV-ND45C/A-T GMV-ND50C/A-T	220-240V ~ 50Hz	6	1.0/AWG18	1.0/AWG18

3.15 Installation of Super High Static Pressure Duct Type Indoor Unit

3.15.1 Outline and installation dimension

Model: GMV-ND22PHS/B-T~ GMV-ND180PHS/B-T

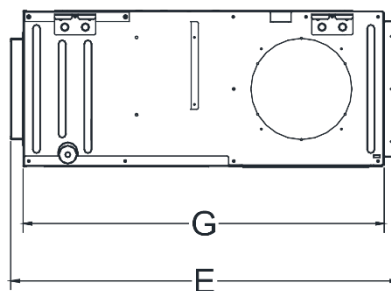
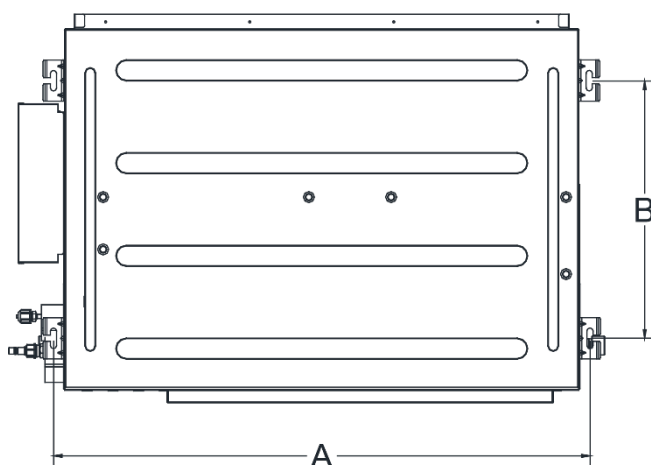
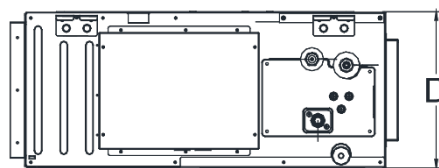
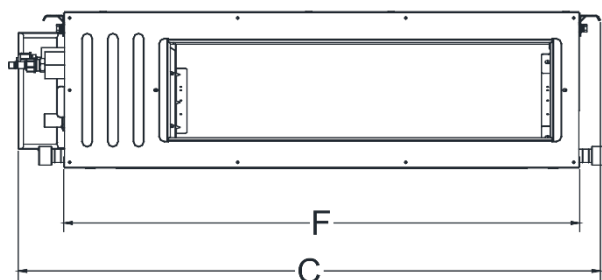

Model: GMV-ND400PH/AR-X, GMV-ND450PH/AR-X

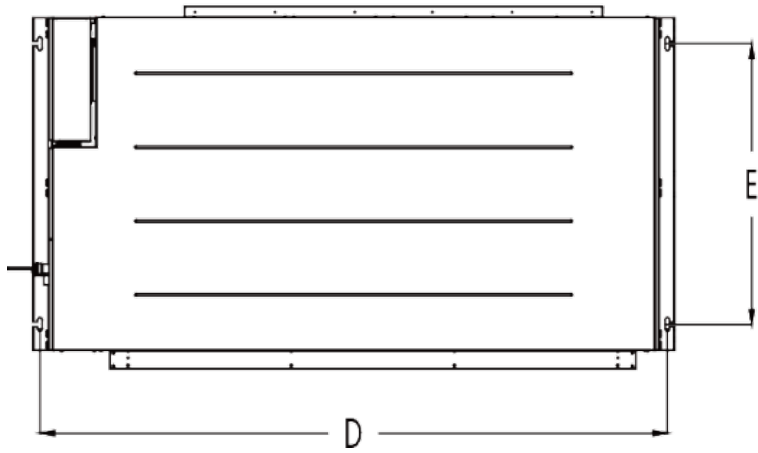
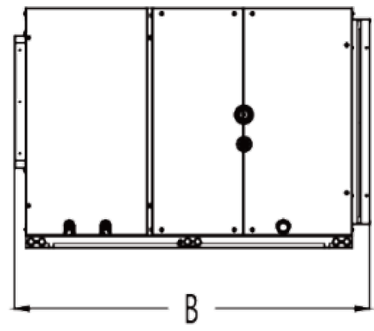
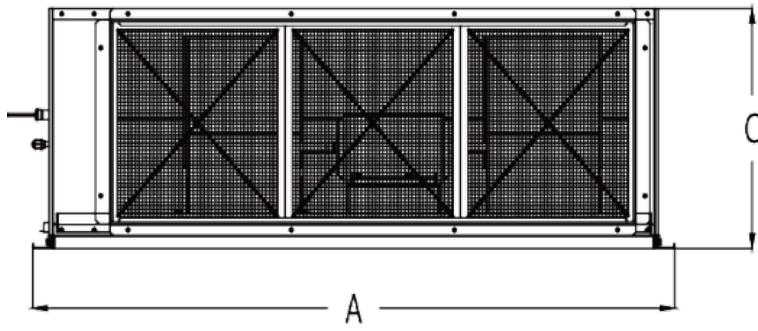

Model: GMV-N560PH/AR-M

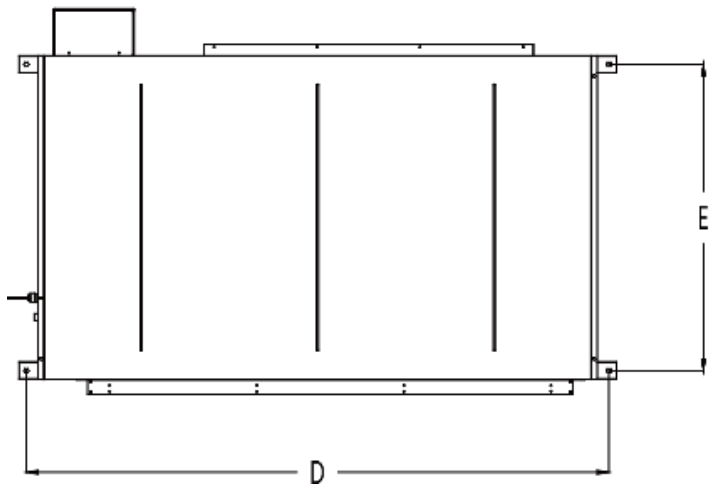
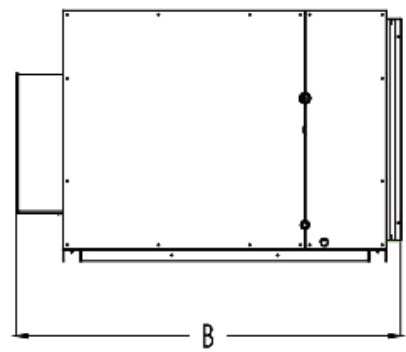
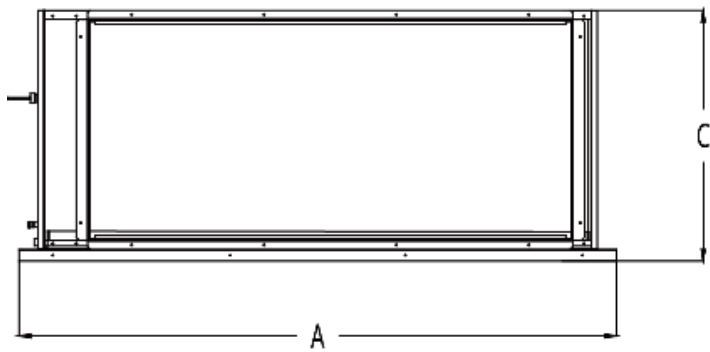

Below are dimensions of A, B, C, etc. for different models:

Unit: mm

Model	A	B	C	D	E	F	G
GMV-ND22PHS/B-T GMV-ND25PHS/B-T GMV-ND28PHS/B-T GMV-ND32PHS/B-T GMV-ND36PHS/B-T GMV-ND40PHS/B-T GMV-ND45PHS/B-T GMV-ND50PHS/B-T	740	500	830	300	754	700	700
GMV-ND56PHS/B-T GMV-ND63PHS/B-T GMV-ND71PHS/B-T GMV-ND80PHS/B-T	1040	500	1130	300	754	1000	700
GMV-ND90PHS/B-T GMV-ND100PHS/B-T GMV-ND112PHS/B-T GMV-ND125PHS/B-T GMV-ND140PHS/B-T GMV-ND160PHS/B-T GMV-ND180PHS/B-T	1440	500	1530	300	754	1400	700
GMV-ND400PH/AR-X	1770	982	650	1730	760	-	-
GMV-ND450PH/AR-X GMV-N560PH/AR-M	2030	1179	700	1980	1040	-	-

3.15.2 Installation space

Unit: mm

Model: GMV-ND22PHS/B-T~ GMV-ND180PHS/B-T

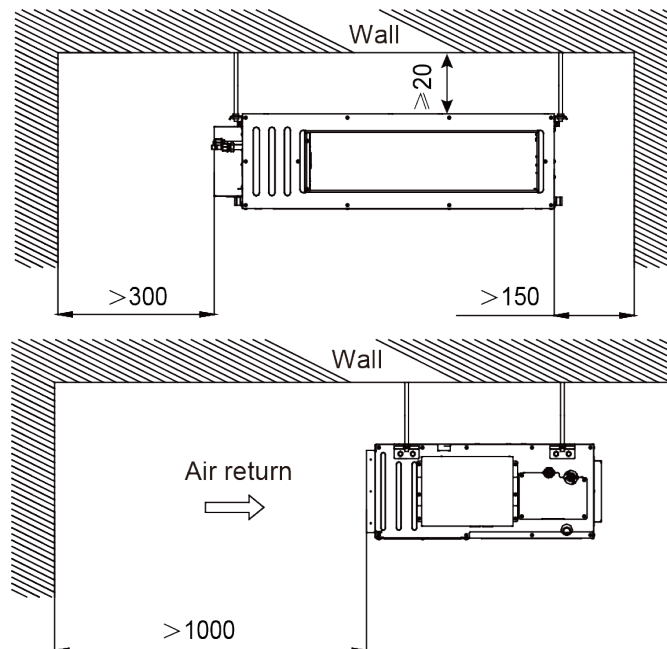

Model: GMV-ND400PH/AR-X, GMV-ND450PH/AR-X, GMV-N560PH/AR-M

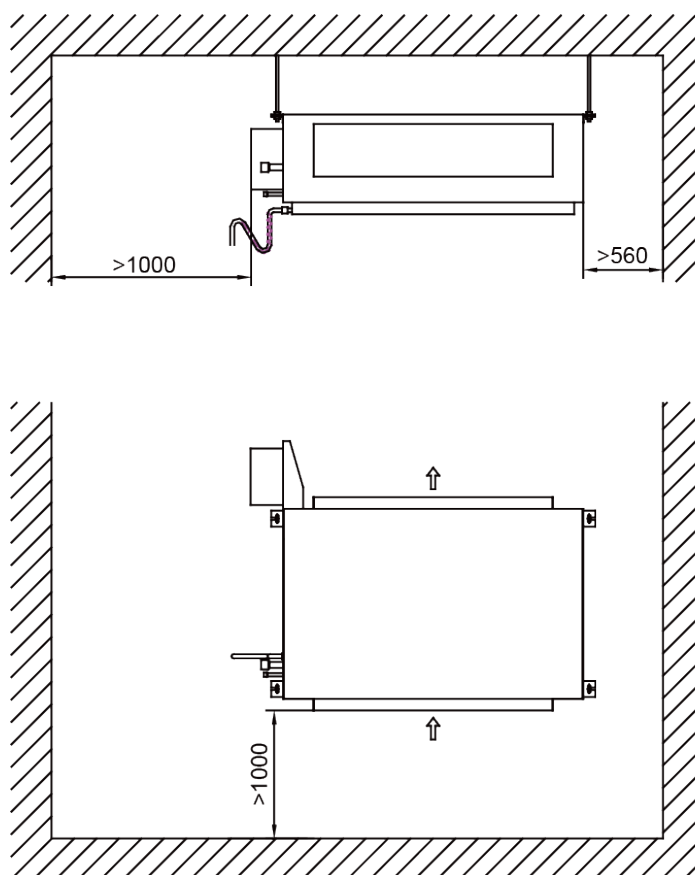

3.15.3 Installation notice

- ◆ The unit shall be installed by the professional personnel according to this installation instruction to ensure proper use.
- ◆ Please contact the local Gree appointed service center before installation. Any malfunction caused by the unit that is not installed by the Gree appointed service center would probably not be dealt with on time because of the inconvenience of the business contact.
- ◆ It should be guided under the professional personnel when the air conditioner unit is moved to other place.
- ◆ Installation of the unit must be in accordance with National Electric Codes and local regulations.
- ◆ Improper installation will affect unit's performance, so do not install the unit by yourself. Please contact local dealer to arrange professional technicians for the installation.
- ◆ Do not connect power until all installation work is finished.
- ◆ If the supply cord is damaged, it must be replaced by the manufacturer or its service agent or a similarly qualified person in order to avoid a hazard.

3.15.4 Selection of air switch and power cord

Model	Power Cord Size	Air Switch Capacity (A)	Minimum Sectional Area of Ground Wire (mm ² /AWG)	Minimum Sectional Area of Power Cord (mm ² /AWG)
GMV-ND22PHS/B-T	220-240V/50Hz 208-230V/60Hz	6	1.0/AWG18	1.0/AWG18
GMV-ND25PHS/B-T	220-240V/50Hz 208-230V/60Hz	6	1.0/AWG18	1.0/AWG18

Model	Power Cord Size	Air Switch Capacity (A)	Minimum Sectional Area of Ground Wire (mm ² /AWG)	Minimum Sectional Area of Power Cord (mm ² /AWG)
GMV-ND28PHS/B-T	220-240V/50Hz 208-230V/60Hz	6	1.0/AWG18	1.0/AWG18
GMV-ND32PHS/B-T	220-240V/50Hz 208-230V/60Hz	6	1.0/AWG18	1.0/AWG18
GMV-ND36PHS/B-T	220-240V/50Hz 208-230V/60Hz	6	1.0/AWG18	1.0/AWG18
GMV-ND40PHS/B-T	220-240V/50Hz 208-230V/60Hz	6	1.0/AWG18	1.0/AWG18
GMV-ND45PHS/B-T	220-240V/50Hz 208-230V/60Hz	6	1.0/AWG18	1.0/AWG18
GMV-ND50PHS/B-T	220-240V/50Hz 208-230V/60Hz	6	1.0/AWG18	1.0/AWG18
GMV-ND56PHS/B-T	220-240V/50Hz 208-230V/60Hz	6	1.0/AWG18	1.0/AWG18
GMV-ND63PHS/B-T	220-240V/50Hz 208-230V/60Hz	6	1.0/AWG18	1.0/AWG18
GMV-ND71PHS/B-T	220-240V/50Hz 208-230V/60Hz	6	1.0/AWG18	1.0/AWG18
GMV-ND80PHS/B-T	220-240V/50Hz 208-230V/60Hz	6	1.0/AWG18	1.0/AWG18
GMV-ND90PHS/B-T	220-240V/50Hz 208-230V/60Hz	6	1.0/AWG18	1.0/AWG18
GMV-ND100PHS/B-T	220-240V/50Hz 208-230V/60Hz	6	1.0/AWG18	1.0/AWG18
GMV-ND112PHS/B-T	220-240V/50Hz 208-230V/60Hz	6	1.0/AWG18	1.0/AWG18
GMV-ND125PHS/B-T	220-240V/50Hz 208-230V/60Hz	6	1.0/AWG18	1.0/AWG18
GMV-ND140PHS/B-T	220-240V/50Hz 208-230V/60Hz	6	1.0/AWG18	1.0/AWG18
GMV-ND160PHS/B-T	220-240V/50Hz 208-230V/60Hz	6	1.0/AWG18	1.0/AWG18
GMV-ND180PHS/B-T	220-240V/50Hz 208-230V/60Hz	6	1.0/AWG18	1.0/AWG18
GMV-ND400PH/AR-X	380-415V 3N~50/60Hz	10	1.0/AWG18	1.0/AWG18
GMV-ND450PH/AR-X	380-415V 3N~50/60Hz	10	1.0/AWG18	1.0/AWG18
GMV-N560PH/AR-M	380V 3N~50Hz	10	1.0/AWG18	1.0/AWG18

3.16 Installation of AHU-KIT Type

3.16.1 Outline and installation dimension

Unit: mm

- (1) Size of control box for GMV-N36U/A-T, GMV-N71U/A-T, GMV-N140U/A-T, GMV-N280U/A-T, GMV-N560U/A-T, GMV-N36U/B-T, GMV-N71U/B-T, GMV-N140U/B-T, GMV-N280U/B-T and GMV-N560U/B-T:

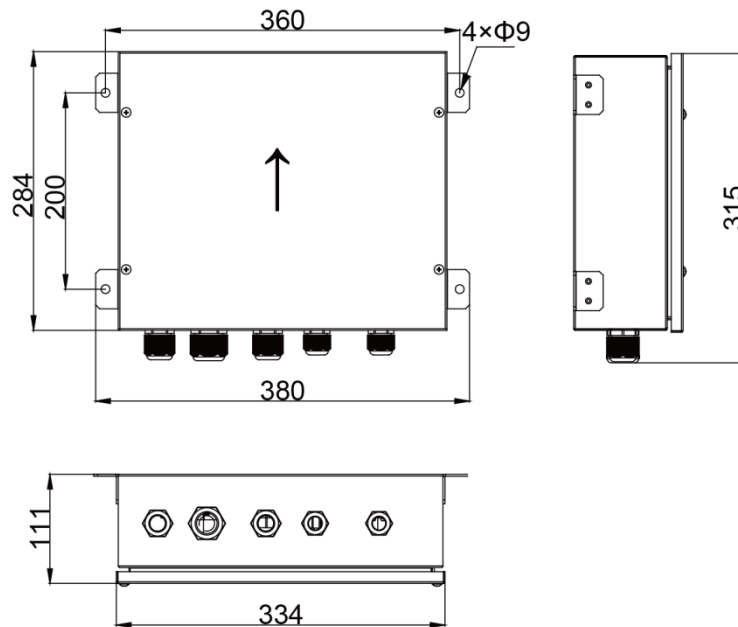

- (2) Size of control box for GMV-N36U/C-T, GMV-N71U/C-T, GMV-N140U/C-T, GMV-N280U/C-T and GMV-N560U/C-T:

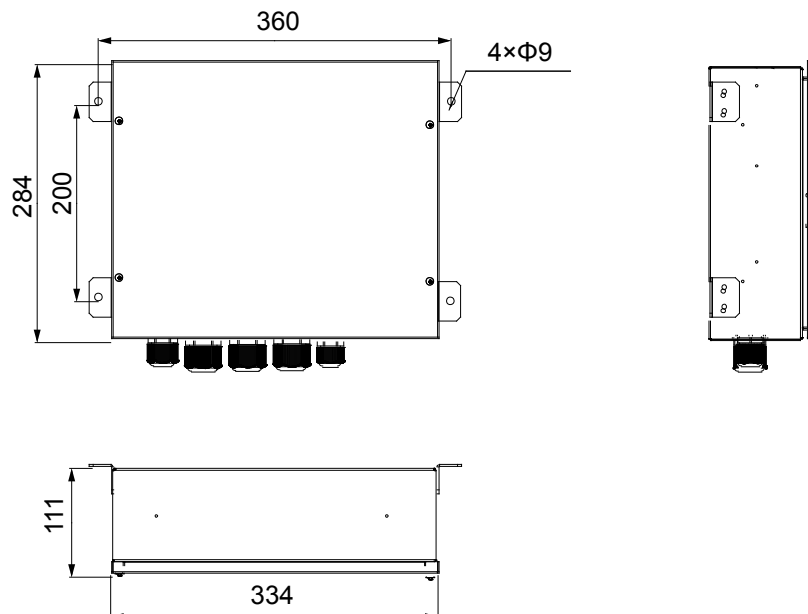

(3) Size of EXV box for GMV-N36U/A-T, GMV-N71U/A-T, GMV-N140U/A-T and GMV-N280U/A-T:

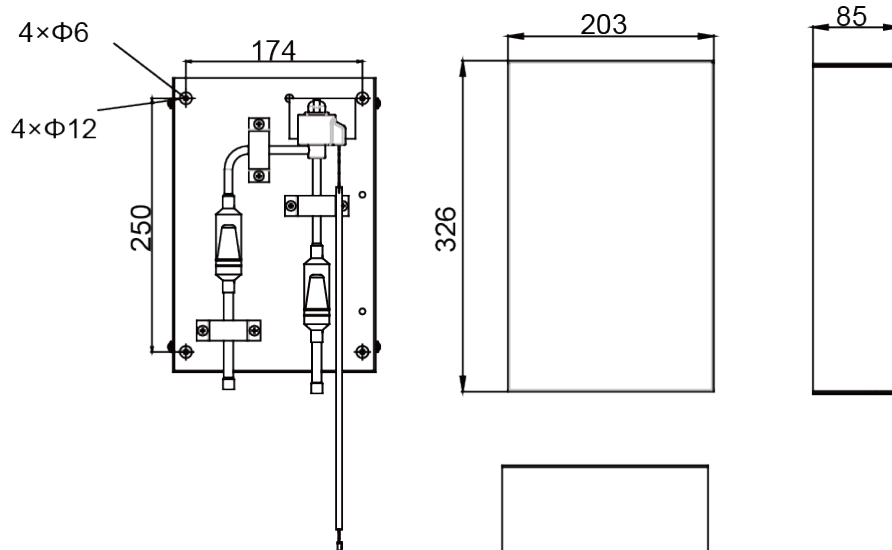

(4) Size of EXV box for GMV-N560U/A-T:

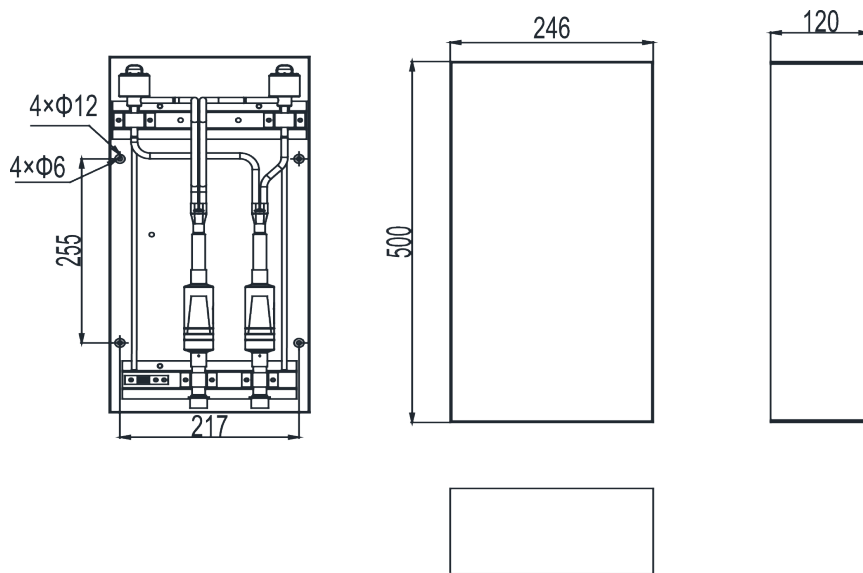

(5) Size of EXV box for GMV-N36U/B-T and GMV-N36U/C-T:

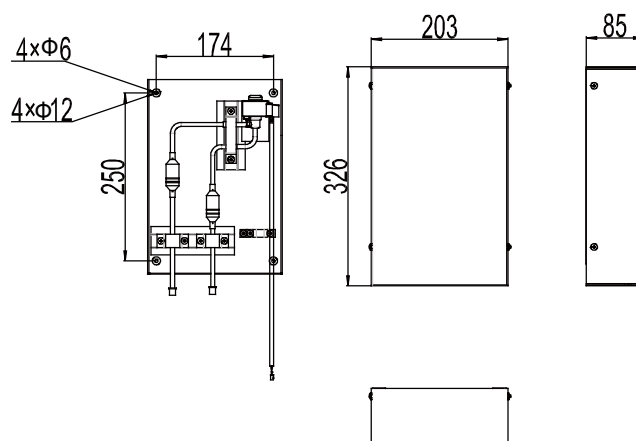

- (6) Size of EXV box for GMV-N71U/B-T, GMV-N140U/B-T, GMV-N280U/B-T, GMV-N71U/C-T, GMV-N140U/C-T and GMV-N280U/C-T:

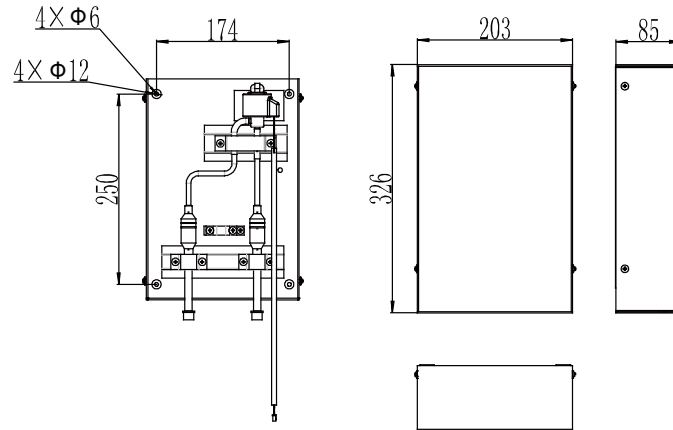

- (7) Size of EXV box for GMV-N560U/B-T and GMV-N560U/C-T:

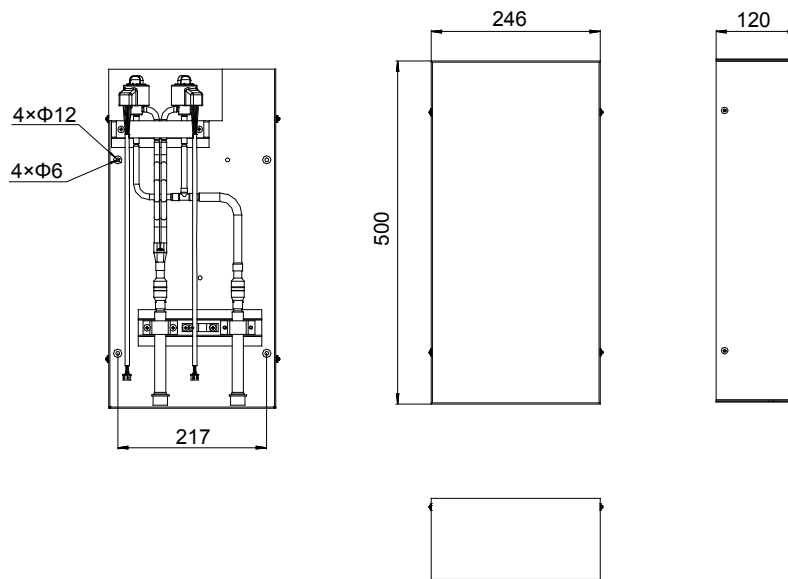

3.16.2 Installation space

Unit: mm

(1) Maintenance space of control space:

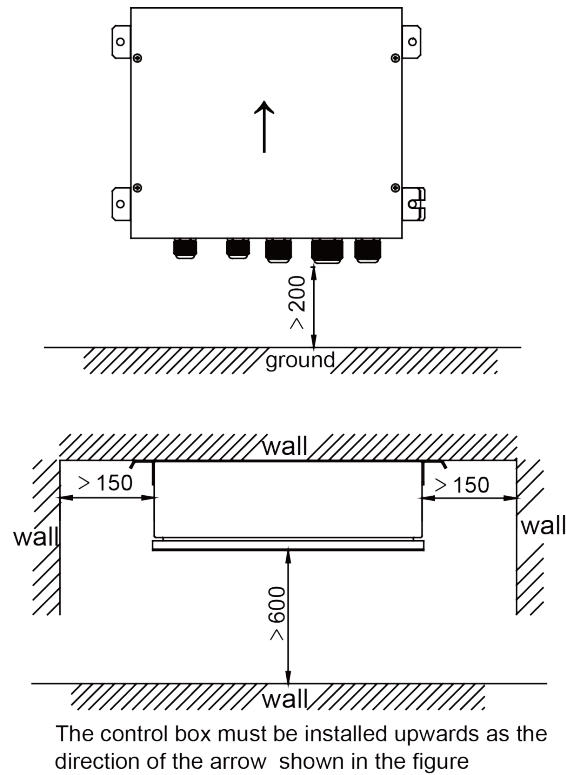

(2) Maintenance space of EXV box:

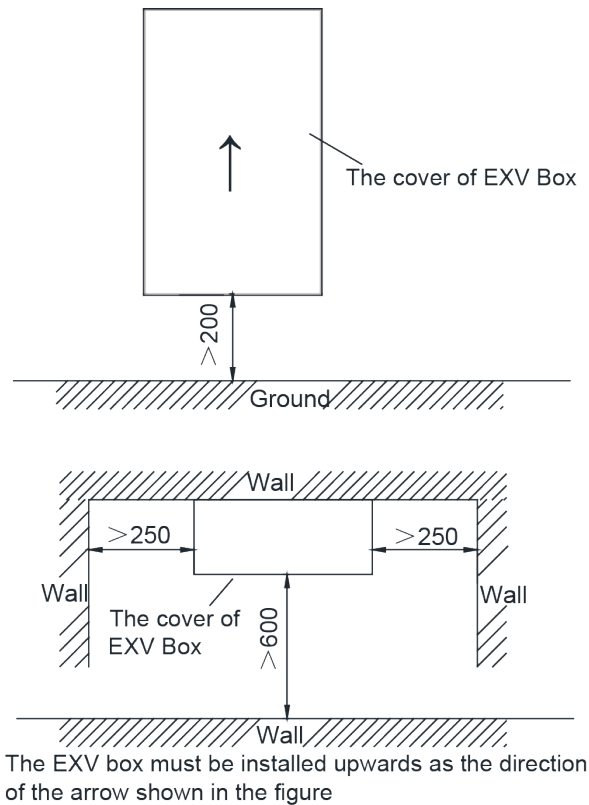

3.16.3 Installation notice

- ◆ The EXV box can be installed inside and outside. The control box should be installed inside.
- ◆ Do not install the EXV box in or on the outdoor unit.
- ◆ Do not put the option boxes in direct sunlight. Direct sunlight will increase the temperature inside the option boxes and may reduce its lifetime and influence its operation.
- ◆ Choose a flat and strong mounting surface.
- ◆ Make sure there is enough free space in front and in the side of the AHU-KIT unit for future maintenance.
- ◆ The installation site should be far away from heat source, inflammable gas and smoke.
- ◆ Keep the air handling unit, power supply wiring and transmission wiring at least 1 m away from televisions and radios. This is to prevent image interference and noise in those electrical appliances (Noise may be generated depending on the conditions under which the electric wave is generated, even if 1 m is kept).
- ◆ Make sure the electronic expansion valve is installed in an upright position.

3.16.4 EXV Installation

3.16.4.1 Mechanical Installation

- (1) Remove the EXV box cover by unscrewing screws.
- (2) Drill 4 holes on correct position (measurements as indicated in figure below) and fix the valve kit box securely with 4 screws through the provided holes $\varnothing 12$ mm.



Notes:

- ① Make sure that the EXV box is installed upwards.
- ② Make sure there is enough free space in front and in the side of the box for future maintenance.

3.16.4.2 Brazing Work

- (1) Prepare the inlet/outlet field piping just in front of the connection (do not braze yet).

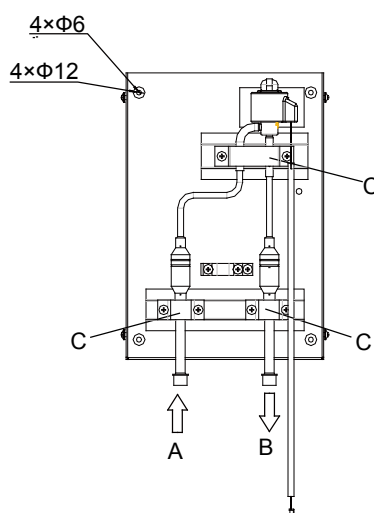

A: Inlet coming from the outdoor unit

B: Outlet to air handling unit

C: Wire clamp

- (2) Remove the wire clamp (C) by unscrewing 6xM4.2.

(3) Braze the field piping.



Notes:

- ① Make sure there is nitrogen protection during welding.
Braze without carrying out nitrogen replacement or releasing nitrogen into the piping will create large quantities of oxidized film on the inside of the pipes, adversely affecting valves and compressors in the refrigerating system and preventing normal operation.
- ② When brazing while inserting nitrogen into the piping, nitrogen must be set to 0.02 MPa with a pressure-reducing valve (=just enough so that it can be felt on the skin).

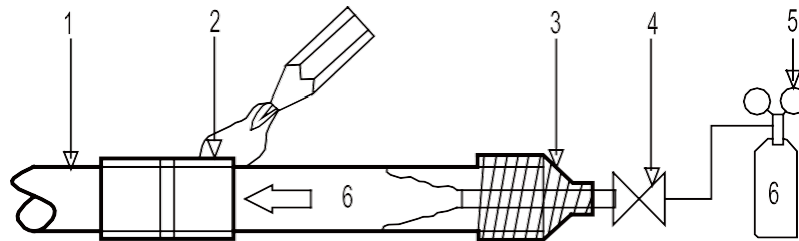

- 1: Refrigerant piping
- 2: Part to be brazed
- 3: Taping
- 4: Hands valve
- 5: Pressure-reducing valve
- 6: Nitrogen

For details, see manual of the outdoor unit.

- ③ Make sure to cool the filters and valve body with a wet cloth and make sure the body temperature does not exceed 120°C during brazing.
- ④ Make sure that the other parts such as electrical box, tie wraps and wires are protected from direct brazing flames during brazing.
- ⑤ The EXV box is required to be installed in a vertical direction within the range of 90±15° (not allowed for horizontal work). Welding the connection tubes first before refrigerant pipes in order to avoid face-down soldering.
- ⑥ All field piping must be provided by a licensed refrigeration technician and must comply with the relevant local and national codes.
 - a) For refrigerant piping of outdoor unit, refer to the installation manual supplied with the outdoor unit.
 - b) The maximum allowed piping length depends on the connected outdoor model.
- ⑦ Secure the wire clamp (C) in place again (6xM4.2).
- ⑧ Make sure that field pipes are fully insulated. Make sure that there is no gap between both ends in order to avoid condensation dripping (finish the connection with tape eventually).

3.16.5 Piping Installation

When one AHU-KIT is connected to one AHU, the piping installation diagram is as follows:

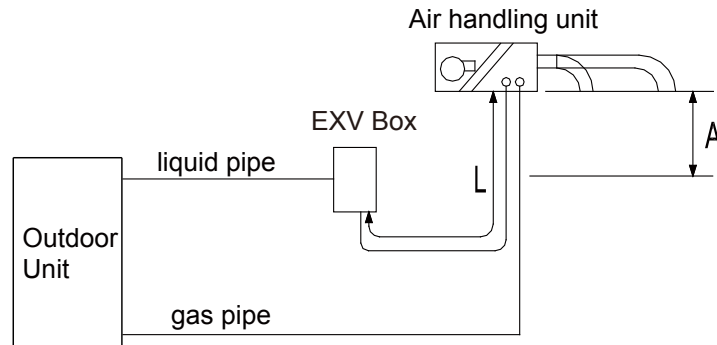

When several AHU-KITs are connected to one AHU, the piping installation diagram is as follows:

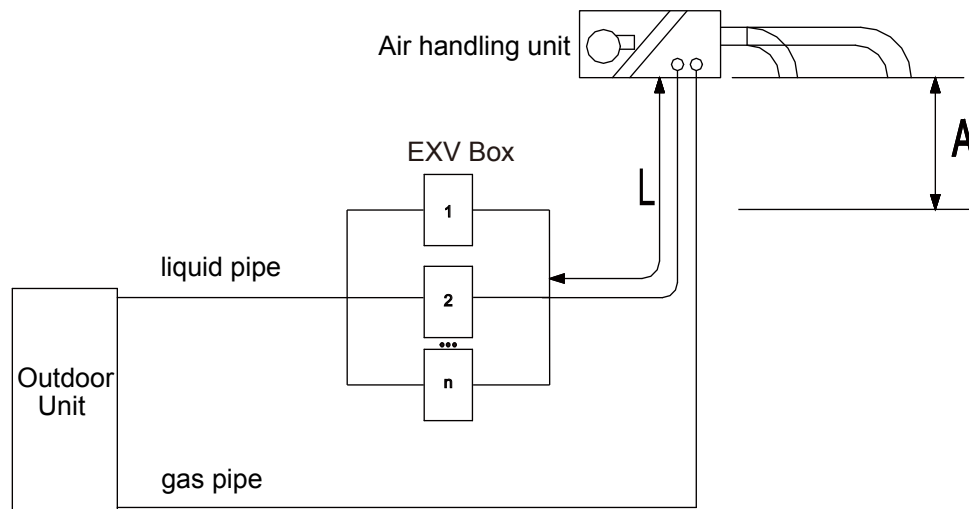

Notes:

A: When the air handling unit is installed at the top of the EXV box, vertical distance between the bottom of the air handling unit to the EXV box is no more than 2 m; if the air handling unit is installed under the EXV box, vertical distance between the bottom of the air handling unit to the EXV box is no more than 2 m.

L: The length of liquid pipe between the air handling unit to EXV box is no more than 2 m.

L is to be considered as a part of the total maximum piping length. See installation manual of the outdoor unit for piping installation.

3.16.6 Installation of the Control Box

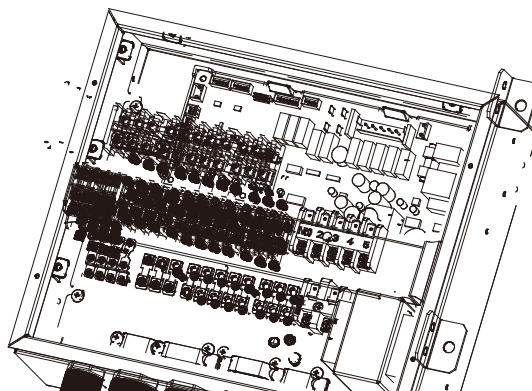

3.16.6.1 Mechanical Installation

- (1) Fix the control box with its hanger brackets to the mounting surface.
- (2) Open the lid of the control box.
- (3) For electrical wiring: refer to the following contents.
- (4) Install the screw nuts.
- (5) Close the unnecessary openings.
- (6) Close the lid securely after installation to ensure that the control box is watertight.

3.16.6.2 Wire connection Inside the Control Box

Wiring of Control Accessories when One AHU-KIT is Connected to One AHU



Notes:

- ① Pull the wires inside through the screw nut and close the nut firmly in order to ensure a good pull relieve and water protection.
- ② The cables require an additional pull relief. Fixing the cable with the wire clamp.

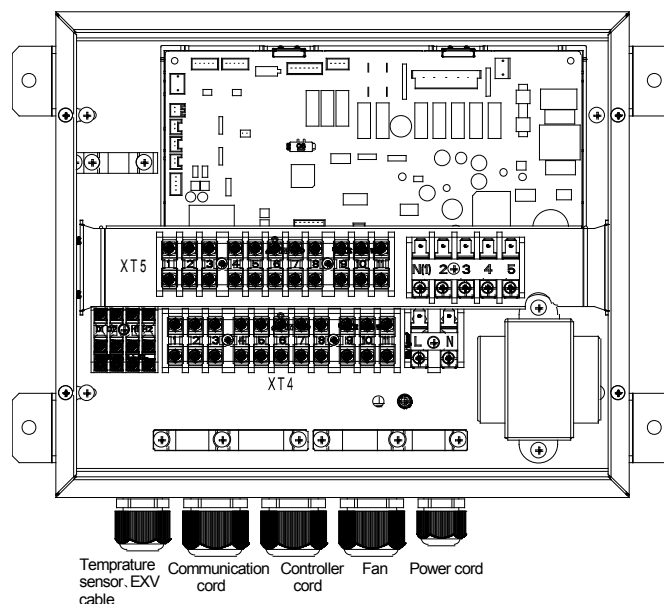

Precautions:

- ① Temperature sensor cable and remote controller wire should be kept away from power cable in a distance of at least 50mm. Violating this rule may generate electric noise and lead to

malfunctions.

- ② Use wires as specified and connect them tightly with wiring terminals. Keep the wires in order and do not obstruct other devices. Insecure connection may result in overheating or even cause electric shock or fire hazard.

Wiring connection:

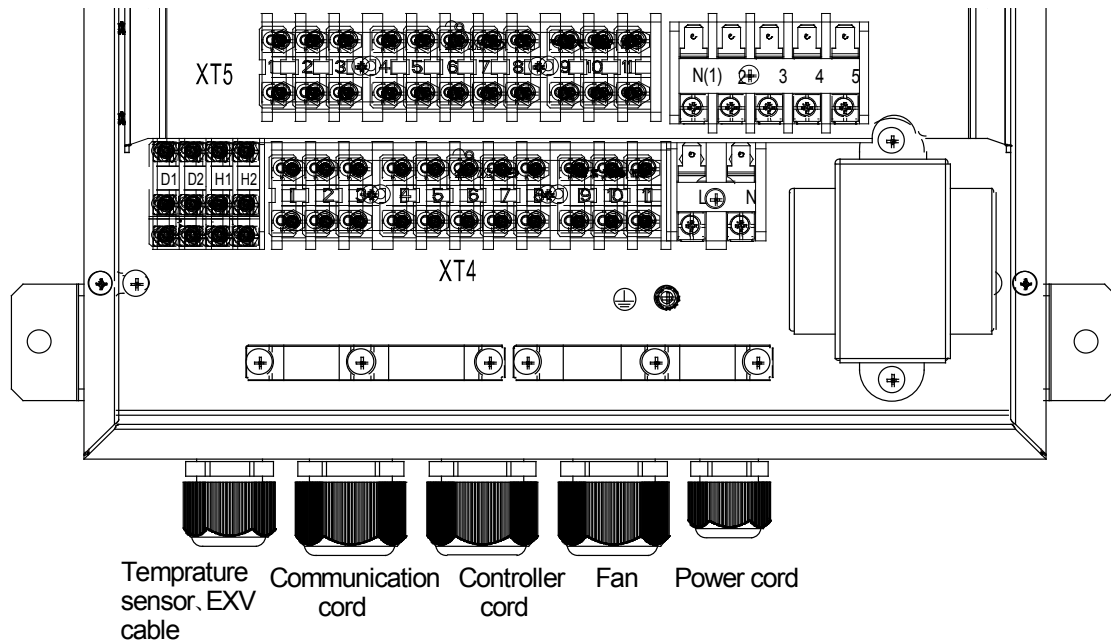

Connecting cables according to the following instructions, as figure shown above.

- L..... Live
 N..... Neutral
 PE..... Protective earth (screw)
 2.....High gear of fan
 3.....Middle gear of fan
 4..... Low gear of fan
 D1/D2.....Communication wires
 H1/H2.....Wired controller

 Notes:

- ① The 2, 3, 4 of fan gear lines are shorted by the factory default.
- ② Neutral line of fan connects to the N (1).
- ③ It can be connected to any of them (2, 3, 4) when there is only one gear.
- ④ Disconnect the short cable between 2 and 3 when there are two gears, then connect the high gear cable to 2, and connect low gear cable to either 3 or 4.
- ⑤ When there are three gears, disconnect the short cables between 2 and 3, 3 and 4, then connect the high gear cable, middle gear cable and low gear cable to 2,3,4 for each.
- ⑥ Pull the wires inside through the screw nut and close the nut firmly in order to ensure a good pull relieve and water protection.
- ⑦ Put through the wires to the coil, tighten the coil while maintaining loose condition of wires to ensure it is not closely tied up and is waterproof.

- ⑧ Wiring connection of XT4 and XT5 refer to the following contents.

Wiring of Control Accessories when Several AHU-KITs are in Parallel Connection with One AHU

For the wiring of control accessories when several AHU-KITs are in parallel connection with one AHU, connect fan control wire and external signal feedback signal wire of air handling unit to any one AHU-KIT. Please refer to the wiring method of AHU-KIT for the connection method.

3.16.7 Installation of the Temperature Sensors

3.16.7.1 Refrigerant Temperature Sensors

Location of the temperature sensor: A correct installation of the temperature sensors is required to ensure a good operation:

- (1) IN Temp. sensor (Liquid Temp. sensor)

Install the IN temperature sensor after the distributor and on the coldest temperature pipe of a heat exchanger.

- (2) OUT Temp. sensor (Gas Temp. sensor)

Install the OUT temperature sensor 200mm after the outlet of the heat exchanger.

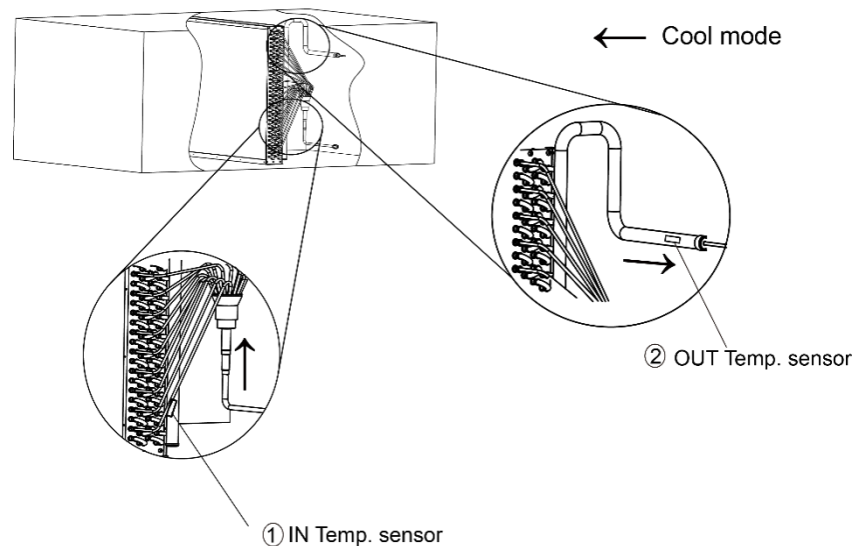

① IN Temp. sensor (Liquid Temp. sensor)

② OUT Temp. sensor (Gas Temp. sensor)

Installation of the temperature sensor cable:

- (1) The length of temperature sensor wire is 10 m.
- (2) Put the temperature sensor cable in an individual protective tube.
- (3) Apply stress release in the temperature sensor wire to prevent the temperature sensor wire from getting loose due to stress. Stress or looseness of temperature sensor wire will lead to poor contact and inaccuracy of temperature measuring.

Fixation of the temperature sensor:

- 1) Put the temperature sensor wire slightly down to avoid water accumulation on top of the temperature sensor.

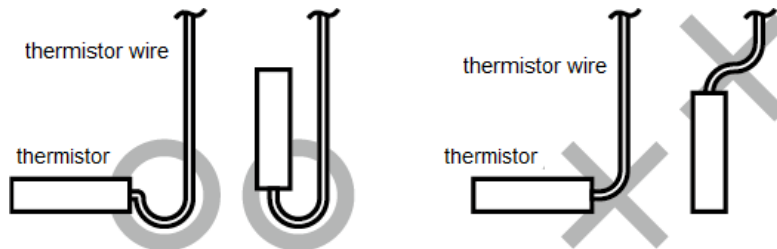

- 2) Keep the temperature sensor and air handling unit in good contact. Put the top of the temperature sensor on the air handling unit, because the top of temperature sensor is the most sensitive part. Please fixing the temperature sensor on the horizontal plane of copper tube (within $\pm 30^\circ$), and make them close together.

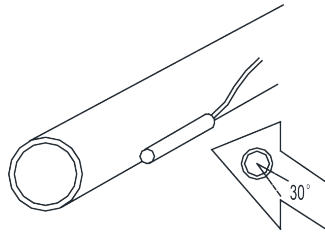

- 3) Fix the temperature sensor with insulating aluminum tape in order to ensure good heat transference.

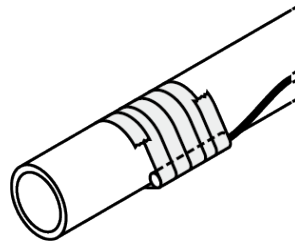

- 4) Cover the temperature sensor with rubber belt to prevent looseness of temperature sensor.

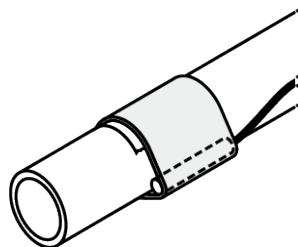

- 5) Use two wire ties to bind the temperature sensor securely.

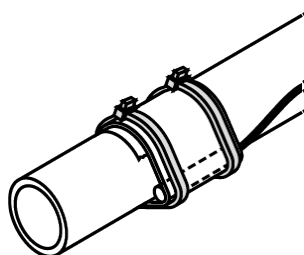

- 6) Wrap the temperature sensor with insulator.

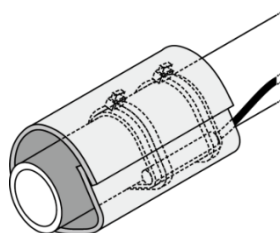

3.16.7.2 Air Temperature Sensor and Air Outlet Temperature Sensor

The air temperature sensor can be installed in the space which needs temperature control, or the inlet scoop of air handling unit.

The air temperature outlet sensor can be installed in the outlet scoop of air handling unit.



Notes:

- ① For connection to outdoor unit and to AHU-KIT unit: Pull the wires inside through the screw nut and close the nut firmly in order to ensure a good pull relieve and water protection.
- ② The cables require an additional pull relief. Fixing the cable with the wire clamp.
- ③ The connection of temperature sensor requires enough space.

3.16.7.3 Installation of Temperature Sensor When Several AHU-KITs are in Parallel Connection with One AHU

When several AHU-KITs are in parallel connection with one AHU, all linkage AHU-KIT inlet pipes' and outlet pipes' temperature sensor must be installed at the position of corresponding pipeline of air handling unit. Install the ambient temperature sensor at the same position of air return outlet. Please refer to above installation method of single AHU-KIT temperature sensor. The installation diagram is as below:

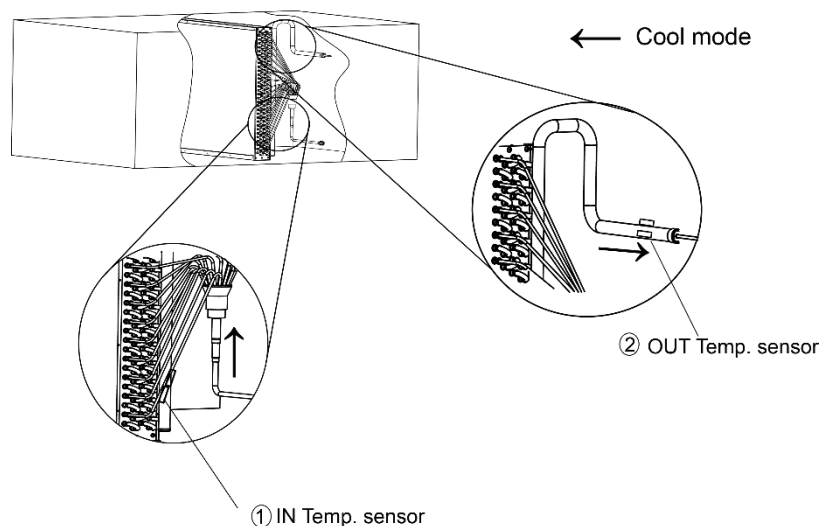

- ① IN Temp. sensor (Liquid Temp. sensor)
- ② OUT Temp. sensor (Gas Temp. sensor)

3.16.8 Installation of the EXV Cable

Installation steps:

- (1) Making the cable terminal through the Cable-Cross Loop, and then winding the cable on the magnetic ring for three times, at last inserting the terminal into a corresponding slot(see circuit diagram).
- (2) Using bundles to fix the magnetic ring is required. It's also need to insert the bundle into the reserved hole on the control box.
- (3) Fixing the cable with the wire clamp, and tightening the Cable-Cross Loop.

Installation requirements:

- (1) Ensure that the cable in the control box is in a relaxed state, and both the joint of terminal and the fixed place of magnetic ring are all not under a stress.
- (2) Ensure that the cable sheath port is located in the control box in order to prevent the rain.

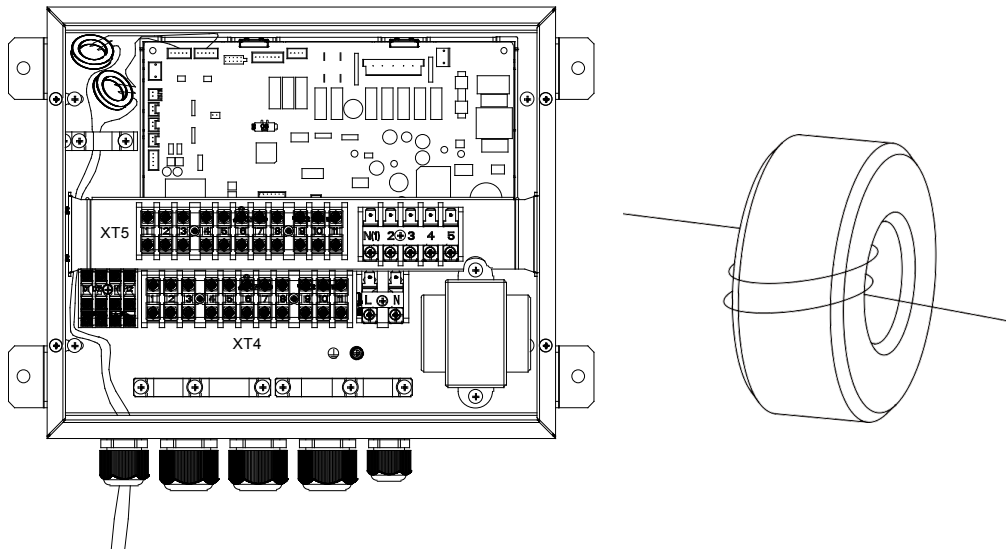

The quantity of expansion valve coil is determined by the actual number of fittings ,The length of EXV Cable wire is 10 m (71,140,280,560 type) or 2.5 m (36 type).

3.16.9 Selection of air switch and power cord

Model	Power Cord Size	Air Switch Capacity(A)	Ground Wire	Power Cord
			Minimum Sectional Area(mm ²)	Minimum Sectional Area(mm ²)
GMV-N36U/A-T	220-240V/1ph/50Hz & 208-230V/1ph/60Hz	6	1.0	1.0
GMV-N71U/A-T		6	1.0	1.0
GMV-N140U/A-T		6	1.0	1.0
GMV-N280U/A-T		6	1.0	1.0
GMV-N560U/A-T		6	1.0	1.0
GMV-N36U/B-T		6	1.0	1.0
GMV-N71U/B-T		6	1.0	1.0
GMV-N140U/B-T		6	1.0	1.0
GMV-N280U/B-T		6	1.0	1.0
GMV-N560U/B-T		6	1.0	1.0
GMV-N36U/C-T		6	1.0	1.0
GMV-N71U/C-T		6	1.0	1.0
GMV-N140U/C-T		6	1.0	1.0
GMV-N280U/C-T		6	1.0	1.0
GMV-N560U/C-T		6	1.0	1.0

3.17 Installation of Concealed Floor Standing Type

3.17.1 Outline and installation dimension

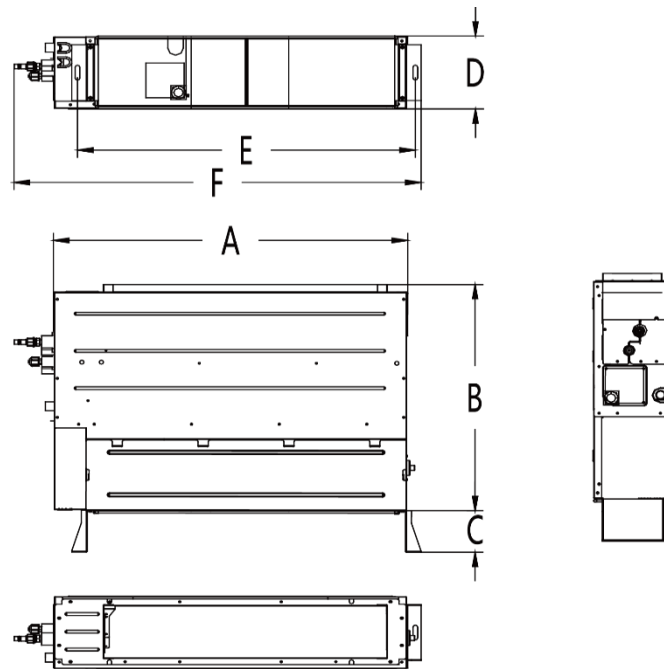

Below are dimensions of A, B, C, etc. for different models:

Unit: mm

Model	A	B	C	D	E	F
GMV-ND22ZA/A-T GMV-ND28ZA/A-T GMV-ND36ZA/A-T	700	615	120	200	665.5	837
GMV-ND45ZA/A-T	900	615	120	200	865.5	1045
GMV-ND56ZA/A-T GMV-ND63ZA/A-T GMV-ND71ZA/A-T	1100	615	120	200	1065.5	1236

3.17.2 Installation space

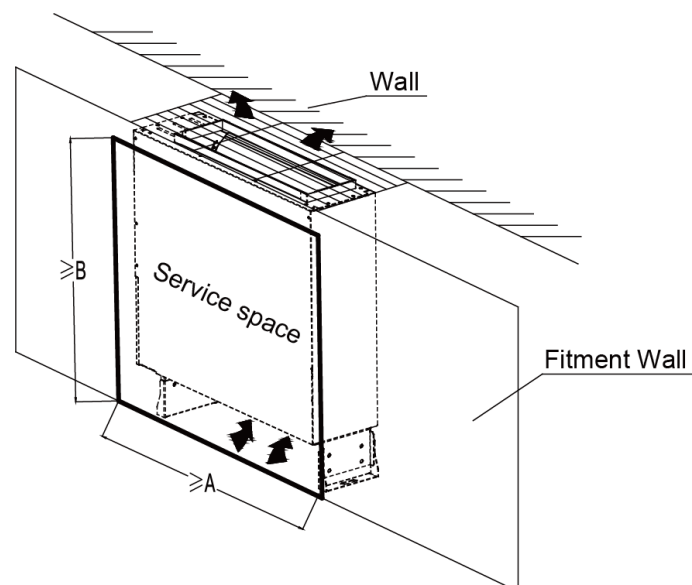

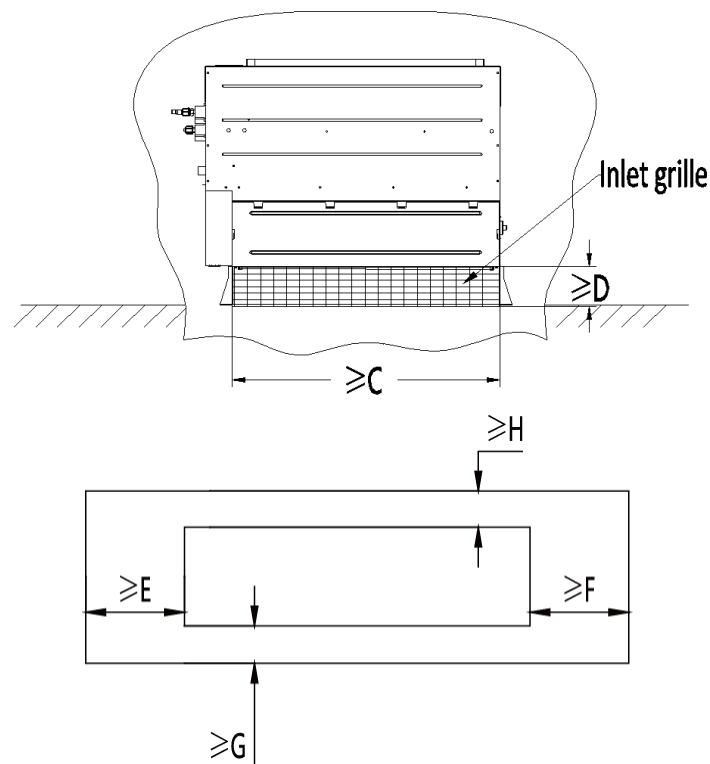

Below are dimensions of A, B, C, etc. for different models:

Unit: mm

Model	A	B	C	D	E	F	G	H
GMV-ND22ZA/A-T	1200	665	615	120	200	200	20	20
GMV-ND28ZA/A-T								
GMV-ND36ZA/A-T								
GMV-ND45ZA/A-T	1400	665	815	120	200	200	20	20
GMV-ND56ZA/A-T								
GMV-ND63ZA/A-T	1600	665	1015	120	200	200	20	20
GMV-ND71ZA/A-T								

3.17.3 Installation notice

- ◆ The unit shall be installed by the professional personnel according to this installation instruction to ensure proper use.
- ◆ Please contact the local Gree appointed service center before installation. Any malfunction caused by the unit that is not installed by the Gree appointed service center would probably not be dealt with on time because of the inconvenience of the business contact.
- ◆ It should be guided under the professional personnel when the air conditioner unit is moved to other place.
- ◆ Installation of the unit must be in accordance with National Electric Codes and local regulations.
- ◆ Improper installation will affect unit's performance, so do not install the unit by yourself. Please contact local dealer to arrange professional technicians for the installation.
- ◆ Do not connect power until all installation work is finished.
- ◆ The height of ex-factory supporter is 120mm. If user wants to increase or decrease unit installation height, please purchase the supporter of different height. Other height of supporter is 80mm, or 160mm.
- ◆ Default height of inlet grille is 120mm. If the supporter of 80mm or 160mm high is selected,

please change the height of inlet grille to 80mm or 160mm accordingly.

3.17.4 Selection of air switch and power cord

Model	Power Cord Size	Air Switch Capacity (A)	Minimum Sectional Area of Ground Wire (mm ² /AWG)	Minimum Sectional Area of Power Cord (mm ² /AWG)
GMV-ND22ZA/A-T	220-240V/50Hz 208-230V/60Hz	6	1.0/AWG18	1.0/AWG18
GMV-ND28ZA/A-T	220-240V/50Hz 208-230V/60Hz	6	1.0/AWG18	1.0/AWG18
GMV-ND36ZA/A-T	220-240V/50Hz 208-230V/60Hz	6	1.0/AWG18	1.0/AWG18
GMV-ND45ZA/A-T	220-240V/50Hz 208-230V/60Hz	6	1.0/AWG18	1.0/AWG18
GMV-ND56ZA/A-T	220-240V/50Hz 208-230V/60Hz	6	1.0/AWG18	1.0/AWG18
GMV-ND63ZA/A-T	220-240V/50Hz 208-230V/60Hz	6	1.0/AWG18	1.0/AWG18
GMV-ND71ZA/A-T	220-240V/50Hz 208-230V/60Hz	6	1.0/AWG18	1.0/AWG18

3.18 Installation of 360° Air Discharge Cassette Type Unit

3.18.1 Outline and installation dimension

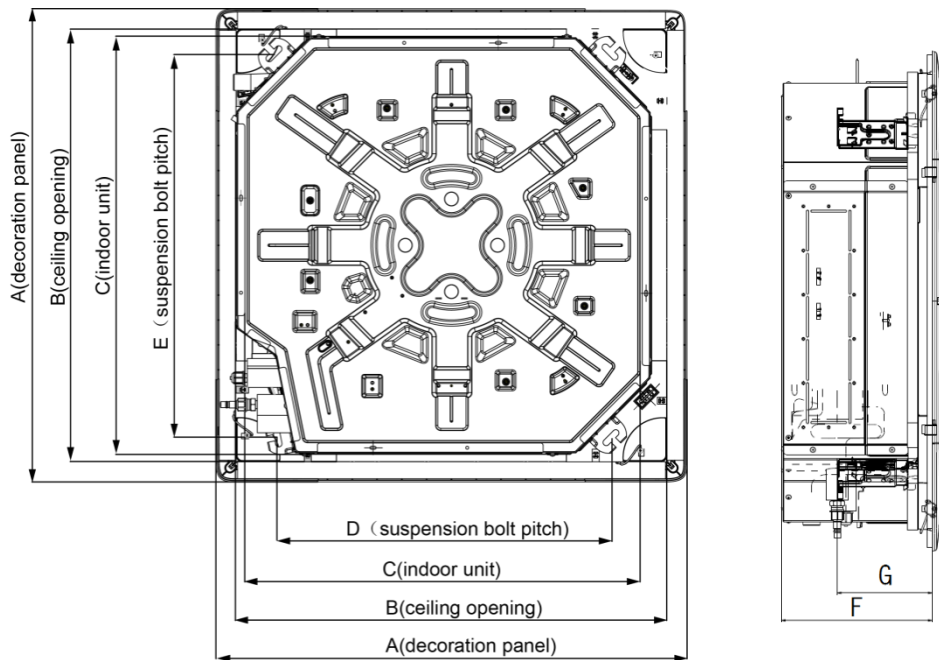

Model	A (mm)	B (mm)	C (mm)	D (mm)	E (mm)	F (mm)	G (mm)	Drainage Pipe(Outer Diameter× wall thickness) (mm)	Outer Diameter of Connection Pipe(mm)	
									Liquid pipe	Gas pipe
GMV-ND22T/C-T	950	890	840	680	780	280	180	Φ25×2.5	6.35	9.52
GMV-ND28T/C-T									6.35	9.52
GMV-ND36T/C-T									6.35	12.7
GMV-ND45T/C-T									6.35	12.7
GMV-ND50T/C-T									6.35	12.7
GMV-ND56T/C-T									9.52	15.9
GMV-ND63T/C-T									9.52	15.9
GMV-ND71T/C-T									9.52	15.9
GMV-ND80T/C-T									9.52	15.9
GMV-ND90T/C-T									9.52	15.9
GMV-ND100T/C-T	9.52	15.9								
GMV-ND112T/C-T	950	890	840	680	780	330	180	Φ25×2.5	9.52	15.9
GMV-ND125T/C-T										
GMV-ND140T/C-T										

3.18.2 Installation space

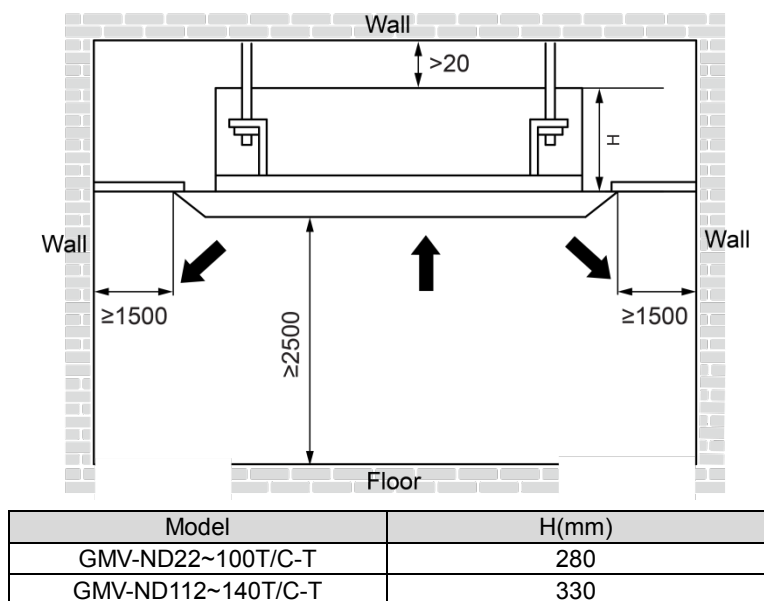

3.18.3 Installation notice

- ◆ The unit shall be installed by the professional personnel according to this installation instruction to ensure proper use.

- ◆ Please contact the local Gree appointed service center before installation. Any malfunction caused by the unit that is not installed by the Gree appointed service center would probably not be dealt with on time because of the inconvenience of the business contact.
- ◆ It should be guided under the professional personnel when the air conditioner unit is moved to other place.
- ◆ The unit shall be installed in accordance with national standards or local regulations.
- ◆ Only qualified personnel can carry out installation work, please contact with local dealer before installation.
- ◆ Make sure all the installation work completed before energizing.

3.18.4 Selection of air switch and power cord

Model	Power Cord Size	Air Switch Capacity (A)	Minimum Sectional Area of Ground Wire (mm ²)	Minimum Sectional Area of Power Cord (mm ²)
GMV-ND22~140T/ C-T	220-240V/50Hz 208-230V/60Hz	6	1.0	1.0

3.19 Installation of Heat Storage Module

3.19.1 Outline and installation dimension

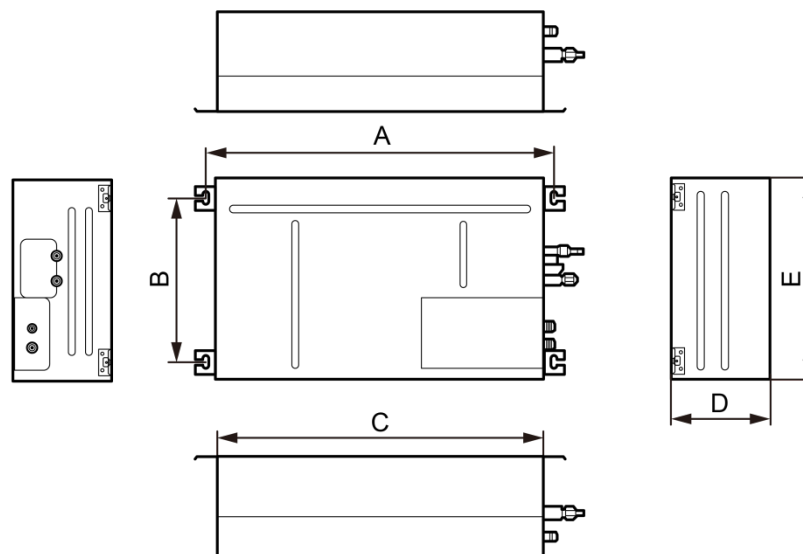
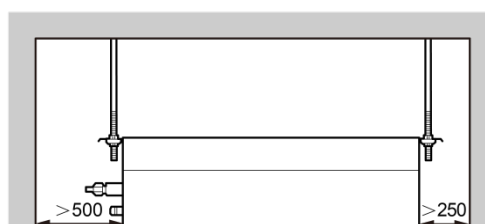

Fig 4.1

Model	A(mm)	B(mm)	C(mm)	D(mm)	E(mm)
XRZ180L/A-T	780	364	730	220	450

3.19.2 Installation space



3.19.3 Installation notice

- ◆ The unit shall be installed by the professional personnel according to this installation instruction to ensure proper use.

- ◆ Please contact the local Gree appointed service center before installation. Any malfunction caused by the unit that is not installed by the Gree appointed service center would probably not be dealt with on time because of the inconvenience of the business contact.
- ◆ It should be guided under the professional personnel when the unit is moved to other place.
- ◆ The unit shall be installed in accordance with national standards or local regulations.
- ◆ Only qualified personnel can carry out installation work, please contact with local dealer before installation.
- ◆ Make sure all the installation work completed before energizing.

3.19.4 Selection of air switch and power cord

Model	Power Cord Size	Air Switch Capacity (A)	Minimum Sectional Area of Ground Wire (mm ²)	Minimum Sectional Area of Power Cord (mm ²)
XRZ180L/A-T	220-240V/50Hz 208-230V/60Hz	6	1.0	1.0

4 Installation of Drain Pipe

4.1 Precautions When Doing the Piping Work

- (1) It is not allowed to connect the condensate drain pipe into waste pipe or other pipelines which are likely to produce corrosive or peculiar smell to prevent the smell from entering indoors or corrupt the unit.
- (2) It is not allowed to connect the condensate drain pipe into rain pipe to prevent rain water from pouring in and cause property loss or personal injury.
- (3) Condensate drain pipe should be connected into special drain system for air conditioner.
- (4) Keep piping as short as possible and slope it downwards at a gradient of at least 1/100 so that air may not remain trapped inside the pipe.
- (5) For example:

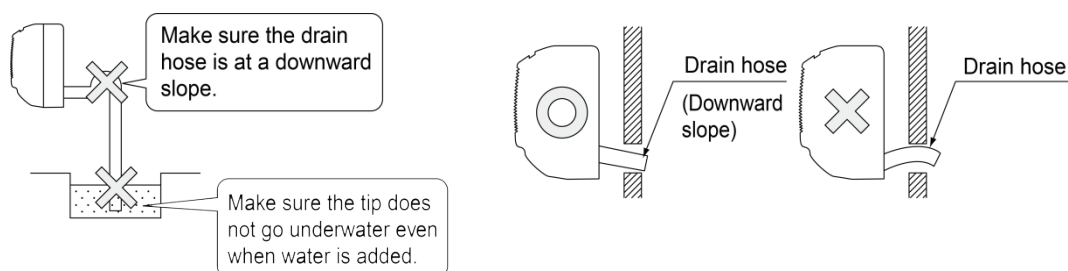

- (6) Keep pipe size equal to or greater than that of the connecting pipe.
- (7) Install the drain piping as shown and take measures against condensation. Improperly rigged piping could lead to leaks and eventually wet furniture and belongings.

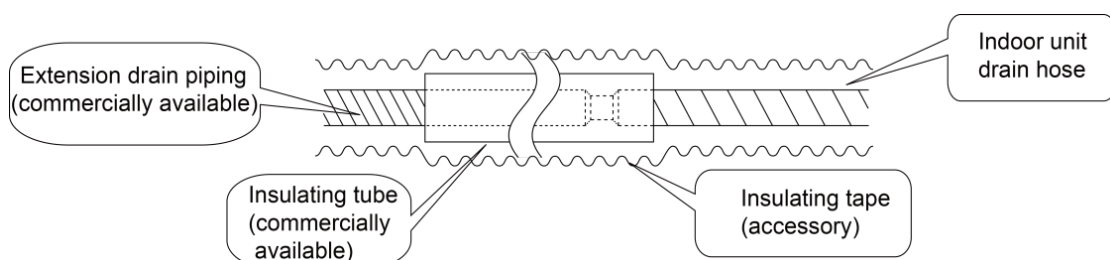

- (8) When directly connecting a hard vinyl chloride pipe joint to the drain hose connected to the

indoor unit, use a commercially available hard vinyl chloride pipe joint (nominal diameter 13mm).

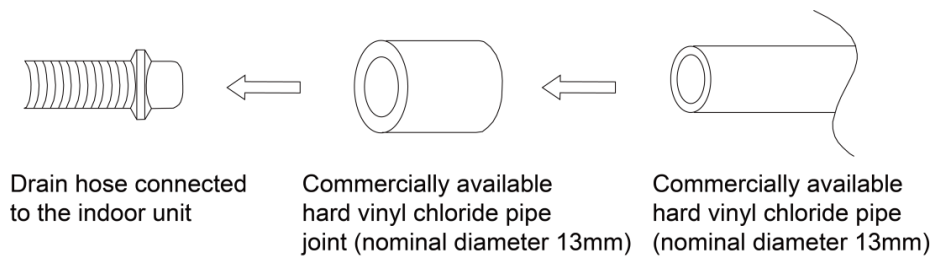

(9) Drain hose connected to the indoor unit commercially available hard vinyl chloride pipe joint (nominal diameter 13mm) commercially available hard vinyl chloride pipe (nominal diameter 13mm).

(10) Do not connect the drain piping directly to sewage pipes that smell of ammonia. The ammonia in the sewage might enter the indoor unit through the drain pipes and corrode the heat exchanger.

4.2 Installing the Drain Pipes

- ◆ Insert the drain hose into the drain outlet, and tighten the clamp securely with tape.
- ◆ Tighten the clamp until the screw head is less than 4 mm from the hose.

- ① Metal clamp(accessory)
- ② Drain hose(accessory)
- ③ Grey tape(accessory)

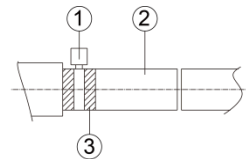

- ◆ Insulate the pipe clamp and the drain hose using heat insulation sponge.

- ① Metal clamp(accessory)
- ② Insulation sponge(accessory)

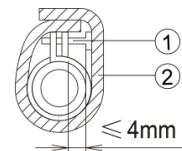

- ◆ Install water trap as shown below.
- ◆ Install one water trap for each unit.
- ◆ Installation of water trap shall consider easy cleaning in the future.

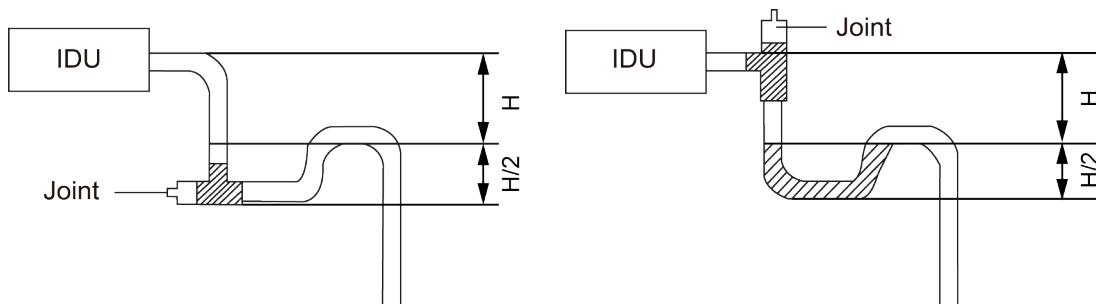

- ◆ Connection of drainage branch pipe to the standpipe or horizontal pipe of drainage main pipe.
- ◆ The horizontal pipe cannot be connected to the vertical pipe at a same height. It can be connected in a manner as shown below:

NO.1: 3-way connection of drainage pipe joint

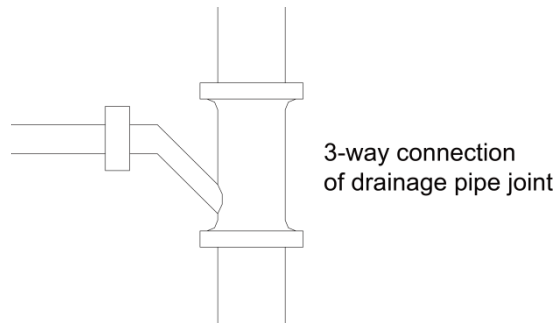

NO.2: Connection of drain elbow

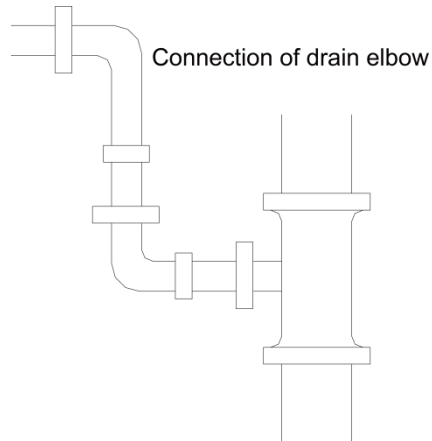

NO.3: Connection of horizontal pipe

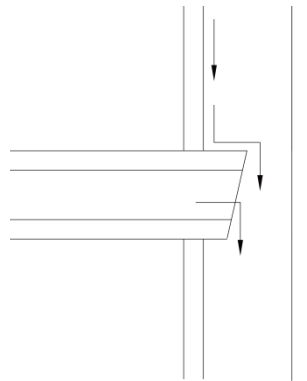

Connection of horizontal pipe

- ◆ When unifying multiple drain pipes, install the pipes as shown below. Select converging drain pipes whose gauge is suitable for the operating capacity of the unit (take the cassette type unit for example).

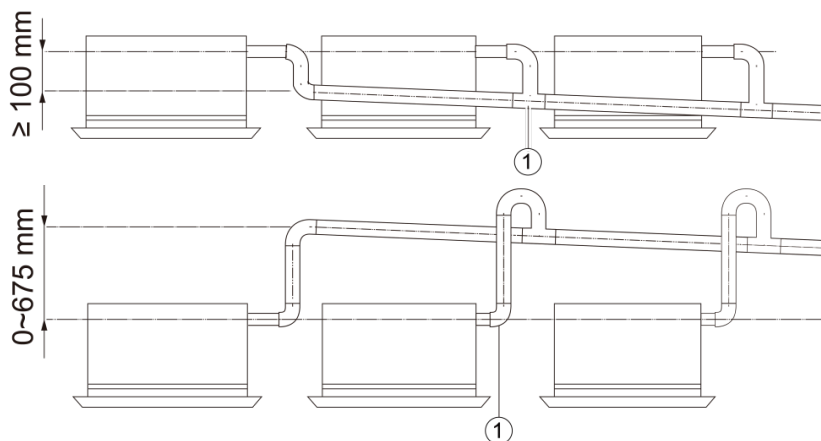

4.3 Precautions When Doing Riser Piping Work

- ◆ Make sure that heat insulation work is executed on the following 2 spots to prevent any possible water leakage due to dew condensation.
 - a) Connect the drain hose to the drain raiser pipe, and insulate them.
 - b) Connect the drain hose to the drain outlet on the indoor unit, and tighten it with the clamp (take the cassette type unit for example).

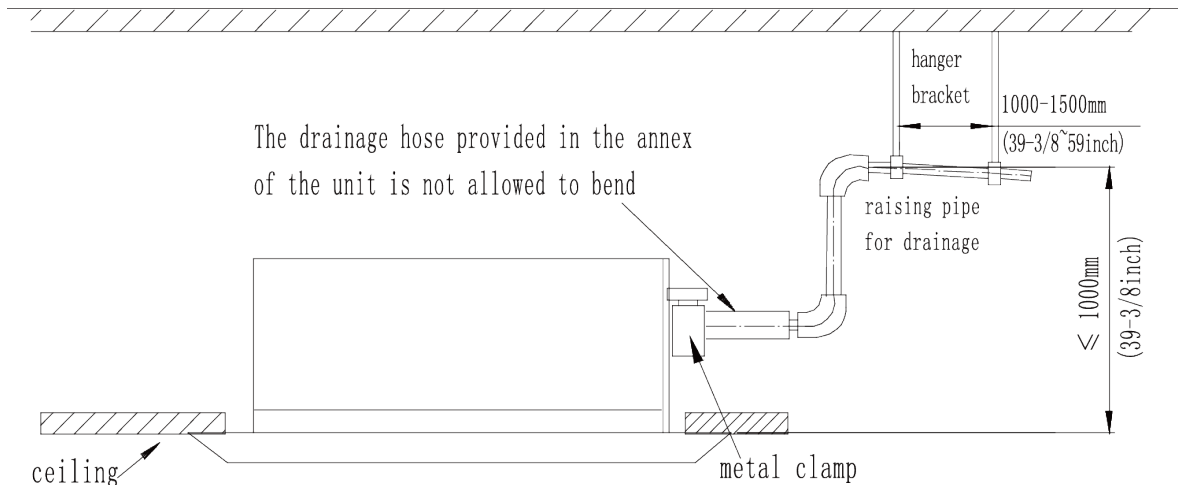

- ◆ Secure a downward gradient of 1/100 or more for the drain pipe. To accomplish this, mount supporting brackets at an interval of 1 - 1.5 m (take the cassette type unit for example).

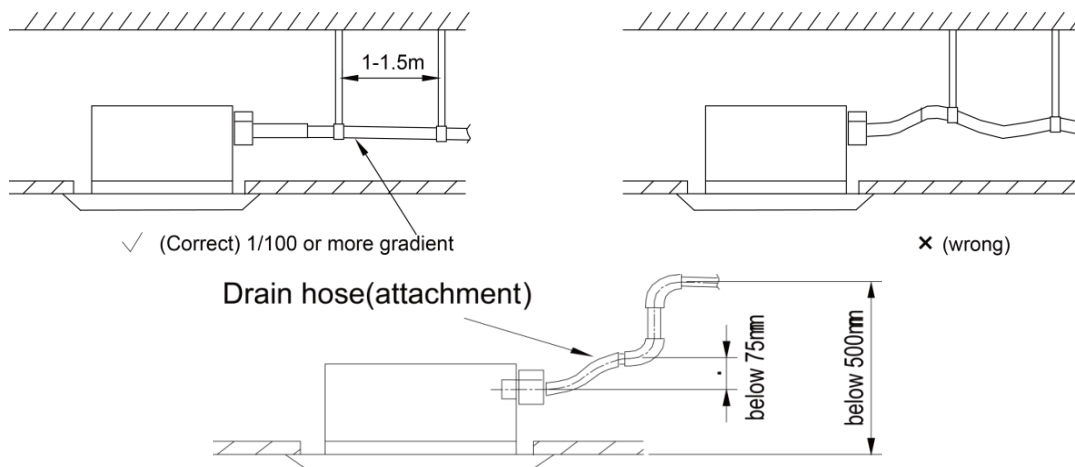

4.4 Testing of Drain Piping

- ◆ After piping work is finished, check if drainage flows smoothly.
- ◆ Shown in the figure, Add approximately 1liter of water slowly into the drain pan and check drainage flow during COOL running.

5 Electrical Installation

- ◆ The wiring must be in accordance with the local rules.
- ◆ Rated supply voltage and special circuit for air conditioner must be used.
- ◆ Do not pull the power cord forcefully.
- ◆ All the electric installations must be carried out by specialist technicians in accordance with the local laws, rules and these instructions.
- ◆ The diameter of flexible wire should be wide enough. Replace the damaged power cord and

connecting wire with special flexible wire.

- ◆ The earthing shall be reliable and connected to the special earthing device on the construction. The installation must be done by specialist technicians. The leak protection switch and air switch with enough capacity must be installed. The air switch shall have both the magnetic tripping and thermal tripping functions to ensure protection against the short circuit and overload.
- Earthed Requirements.
- ◆ The air conditioner belongs to I type electric appliances. The reliable earthed action is a must.
- ◆ The yellow and green wire inside the air conditioner is the earthed wire. Do not use it for other purpose or even cut off it. Do not fix it with tapping screw. Otherwise, it may cause electric shock.
- ◆ The earthed resistance must meet the requirements of national standard GB17790.
- ◆ There should be reliable earthed terminal for the power supply. Never connect the earth lead to the following articles:
 - ①water pipe; ②gas pipe; ③drain pipe; ④unreliable place considered by professionals.

MAINTENANCE

1 Troubleshooting

1.1 Malfunction List for the Wired Controller

Error Code	Content	Error Code	Content	Error Code	Content
L0	Indoor Unit Error	L9	Quantity Of Group Control Indoor Units Setting Error	d7	Humidity Sensor Error
L1	Indoor Fan Protection	LA	Indoor Units Incompatibility Error	d8	Water Temperature Sensor Error
L2	E-heater Protection	LH	Low Air Quality Warning	d9	Jumper Cap Error
L3	Water Full Protection	LC	Outdoor-Indoor Incompatibility Error	dA	Indoor Unit Hardware Address Error
L4	Wired Controller Power Supply Error	d1	Indoor Unit Circuit Board Error	dH	Wired Controller Circuit Board Error
L5	Anti-freezing Protection	d3	Ambient Temperature Sensor Error	dC	Capacity DIP Switch Setting Error
L7	No Master Indoor Unit Error	d4	Inlet Pipe Temperature Sensor Error	dL	Outlet Air Temperature Sensor Error
L8	Power Insufficiency Protection	d6	Outlet Pipe Temperature Sensor Error	dE	Indoor Unit CO ₂ Sensor Error
o1	Over low voltage of IDU bus	o2	Over high voltage of IDU bus	o3	IDU IPM module protection
o4	IDU startup failure	o5	IDU overcurrent protection	o6	IDU current detecting circuit error
o7	IDU non-synchronism protection	o8	IDU drive communication error	o9	Communication error of IDU master controller
oA	Over high temperature of IDU module	ob	Temperature sensor error of IDU module	oC	IDU charging circuit error
o0	Other drive error	db	Special Code: Field Debugging Code		

1.2 Exception Analyzing and Troubleshooting

1.2.1 “d1” Indoor circuit board error

Error display: IDU wired controller and IDU receive light board will display



Error judgment condition and method:

Check if the reading of address chip and memory chip of IDU mainboard is normal. If the data of address chip and memory chip cannot be read, it is abnormal.

Possible reason:

- Address chip is abnormal
- Memory chip is abnormal. Replace main control board directly

Troubleshooting:

Replace main control board directly

1.2.2 “d3” Ambient temperature sensor error

Error display: IDU wired controller and IDU receive light board will display



Error judgment condition and method:

Sample the AD value of temperature sensor through temperature sensor detecting circuit and judge the range of AD value, If the sampling AD value exceeds upper limit and lower limit in 5 seconds continuously, report the error.

Possible reason:

- Poor contact between ambient temperature sensor and terminal in mainboard interface
- Ambient temperature sensor is abnormal
- Detecting circuit is abnormal

Troubleshooting:

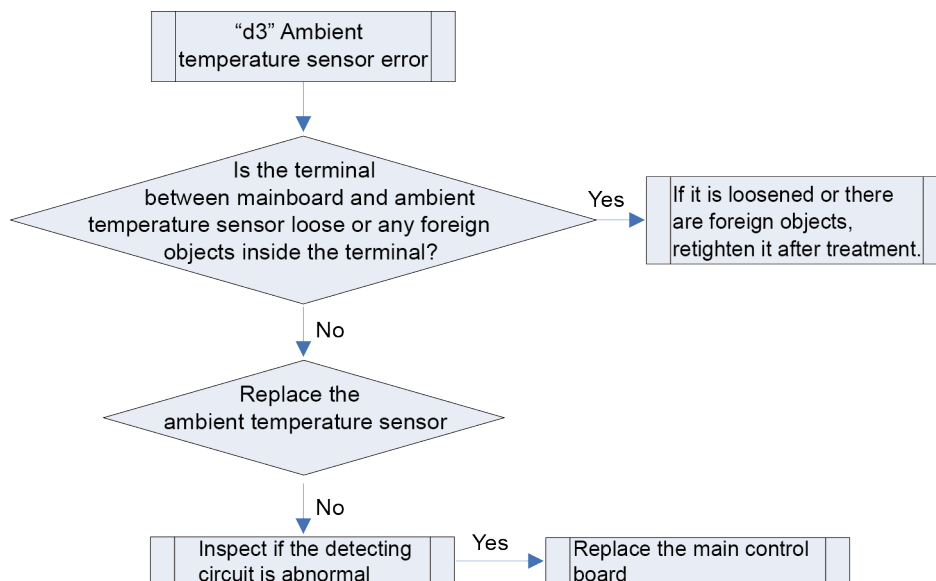

1.2.3 “d4” Inlet pipe temperature sensor error

Error display: IDU wired controller and IDU receive light board will display



Error judgment condition and method:

Sample the AD value of temperature sensor through temperature sensor detecting circuit and judge the range of AD value. If the sampling AD value exceeds upper limit and lower limit in 5 seconds continuously, report the error.

Possible reason:

- Poor contact between inlet pipe temperature sensor and terminal in mainboard interface
- Inlet pipe temperature sensor is abnormal
- Detecting circuit is abnormal

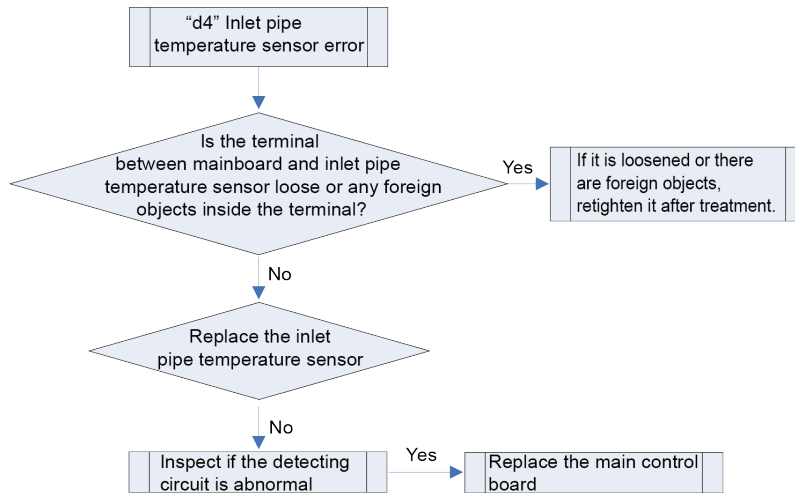
Troubleshooting:**1.2.4 “d6” Outlet pipe temperature sensor error**

Error display: IDU wired controller and IDU receive light board will display

**Error judgment condition and method:**

Sample the AD value of temperature sensor through temperature sensor detecting circuit and judge the range of AD value. If the sampling AD value exceeds upper limit and lower limit in 5 seconds continuously, report the error.

Possible reason:

- Poor contact between outlet pipe temperature sensor and terminal in mainboard interface
- Outlet pipe temperature sensor is abnormal
- Detecting circuit is abnormal

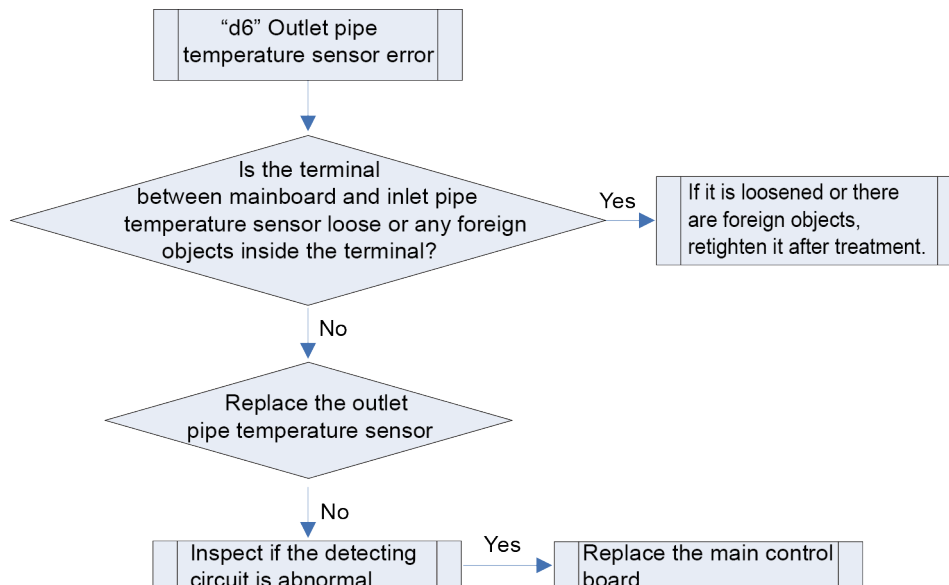
**1.2.5 “d7” Humidity sensor error**

Error display: IDU wired controller and IDU receive light board will display



Error judgment condition and method:

Sample the AD value of temperature sensor through temperature sensor detecting circuit and judge the range of AD value. If the sampling AD value exceeds upper limit and lower limit in 5 seconds continuously, report the error.

Possible reason:

- Poor contact between humidity sensor and terminal in mainboard interface
- Humidity sensor is abnormal
- Detecting circuit is abnormal

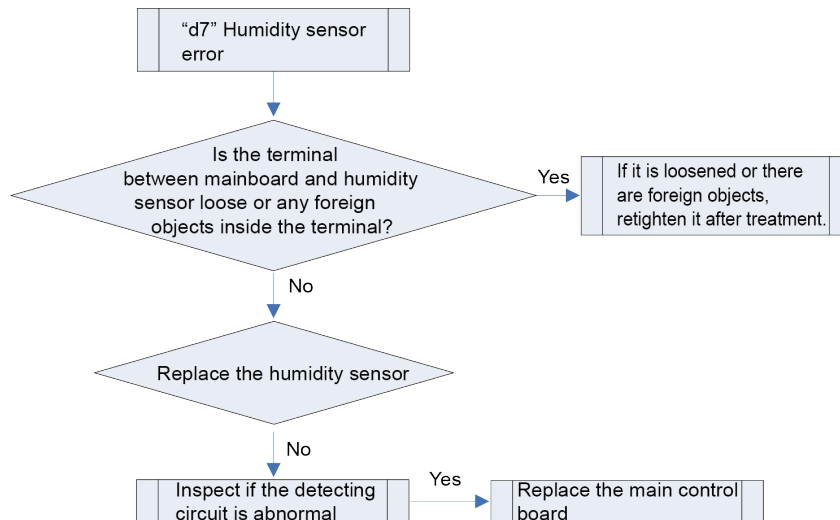
Troubleshooting:**1.2.6 “d9” Jumper cap error**

Error display: IDU wired controller and IDU receive light board will display

**Error judgment condition and method:****Possible reason:**

If jumper cap model doesn't match with mainboard, report the error

- Jumper cap is not installed
- Jumper cap model is wrong
- Detecting circuit is abnormal

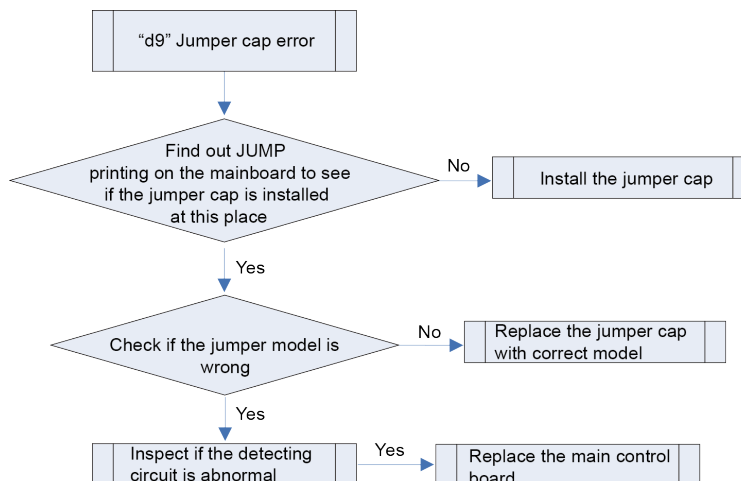
Troubleshooting:

1.2.7 “dA” IDU network address error

Error display: IDU wired controller and IDU receive light board will display



Error judgment condition and method:

Through testing the IDU address chip and IP address, if address chip cannot be read, IDU IP is 0 or IP is in conflict, report the error.

Possible reason:

- ODU allocated address is wrong
- IDU treatment is wrong
- Address chip is abnormal

Troubleshooting:

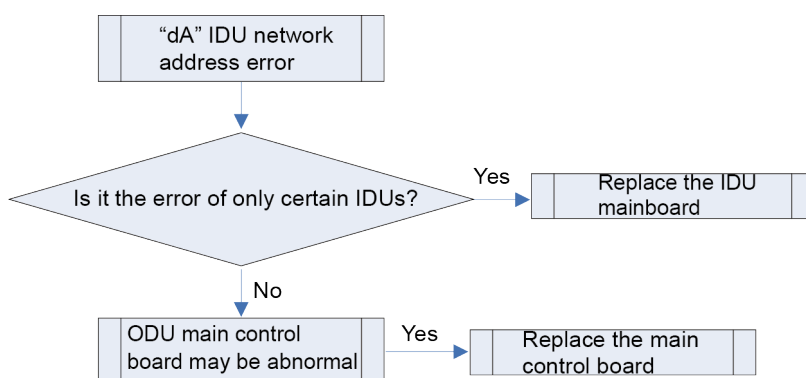

1.2.8 “dH” wired controller circuit board error

Error display: IDU wired controller and IDU receive light board will display



Error judgment condition and method:

Wired controller IIC communication is abnormal

Possible reason:

- Communication of wired controller touch button board and display board IIC is abnormal;
- Read and write of wired controller memory chip IIC is abnormal (when memory chip is existed);

Troubleshooting:

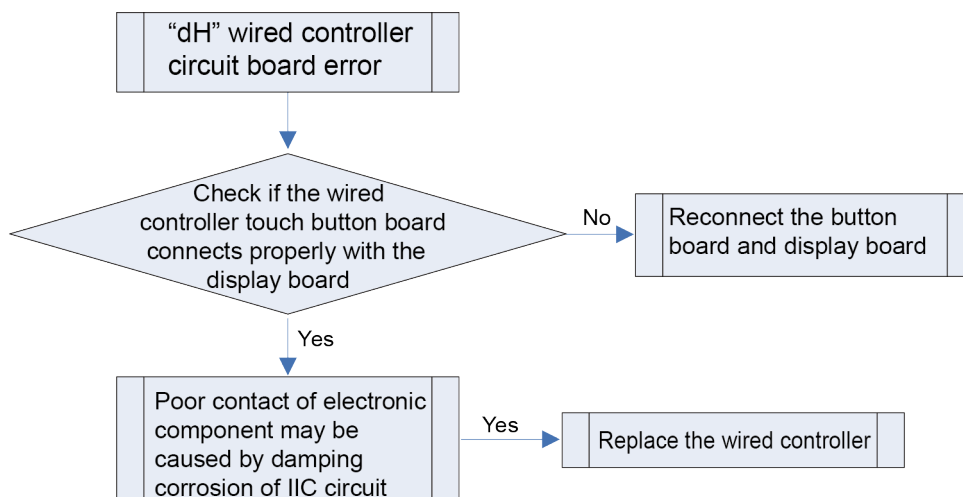

1.2.9 “dC” Capacity DIP switch setting error

Error display: IDU wired controller and IDU receive light board will display



Error judgment condition and method:

If capacity DIP switch is set to the wrong position, report the error.

Possible reason:

- Capacity DIP switch is set to the wrong position
- Detecting circuit is abnormal

Troubleshooting:

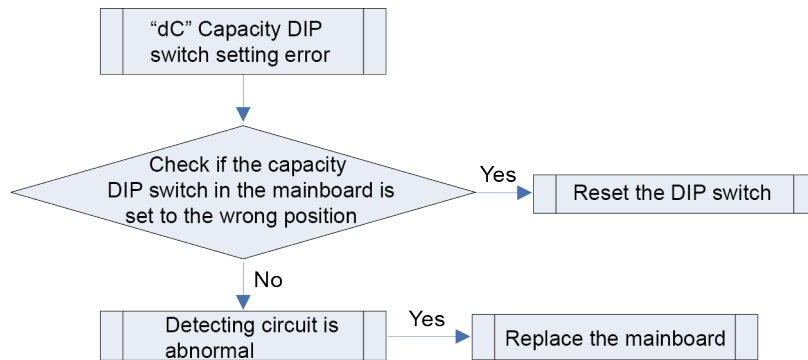

1.2.10 “dL” Air outlet temperature sensor error

Error display: IDU wired controller and IDU receive light board will display



Error judgment condition and method:

Sample the AD value of temperature sensor through temperature sensor detecting circuit and judge the range of AD value. If the sampling AD value exceeds upper limit and lower limit in 5 seconds continuously, report the error.

Possible reason:

- Poor contact between air outlet temperature sensor and terminal in mainboard interface
- Air outlet temperature sensor is abnormal
- Detecting circuit is abnormal

Troubleshooting:

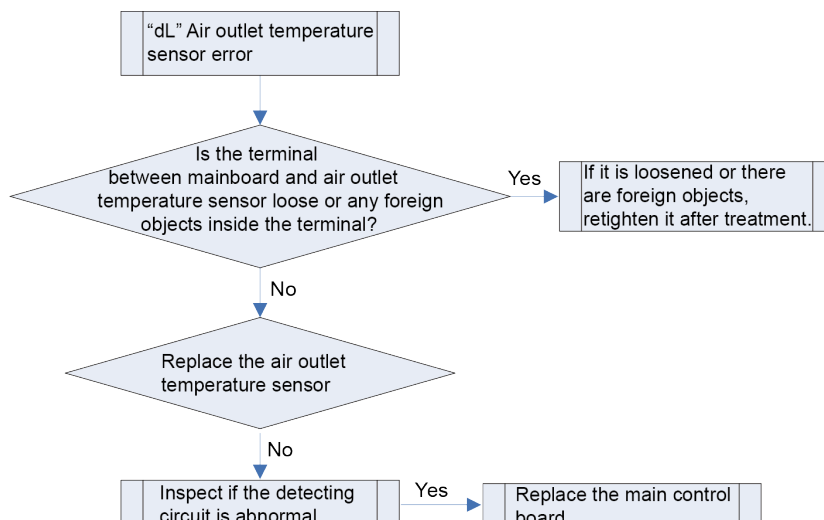

1.2.11 “db” Project debugging

Error display: ODU mainboard, IDU wired controller and IDU receive light board will display



Error judgment condition and method:

This is a status code of project debugging, not an error code. When IDU or ODU displays this code, it means the unit is under debugging status and the IDU cannot be operated.

Troubleshooting: ——

Possible reason: ——

1.2.12 “L1” Indoor fan protection

Error display: IDU wired controller and IDU receive light board will display



Error judgment condition and method:

Check if the rotation speed of IDU is too slow, or it stops rotation, or protection signal of outdoor fan is transferred. If yes, it is judged that indoor fan protection occurs.

Possible reason:

- Motor stops operation or it is blocked
- IDU mainboard is abnormal

Troubleshooting:

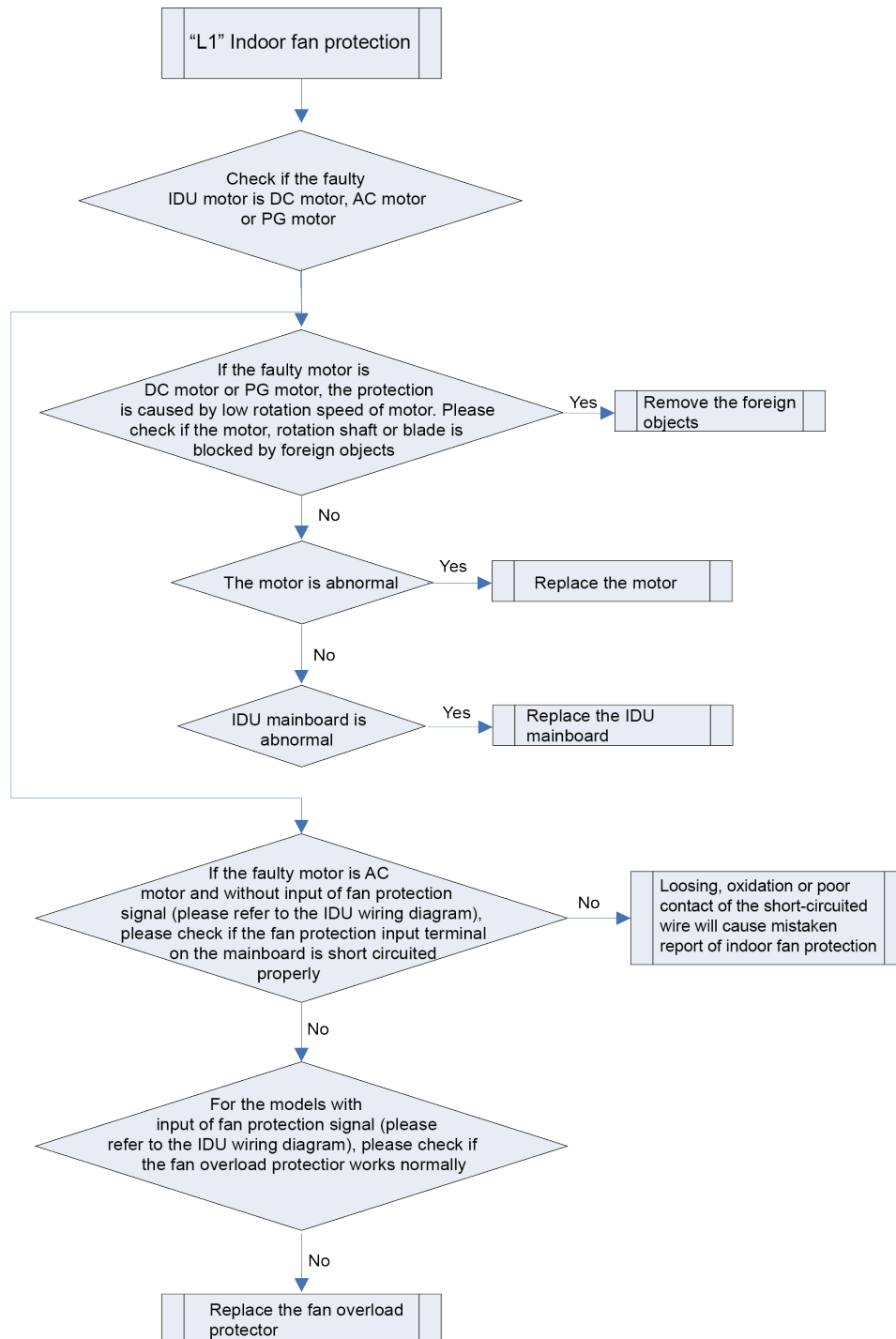

1.2.13 "L3" Water full protection

Error display: IDU wired controller and IDU receive light board will display



Error judgment condition and method:

Check the status of IDU float switch. When water level is too high, float switch is activated, so water full protection happens.

Possible reason:

- IDU is installed improperly
- Drainage pump is broken
- Float switch operates abnormally

■IDU mainboard is abnormal

Troubleshooting:

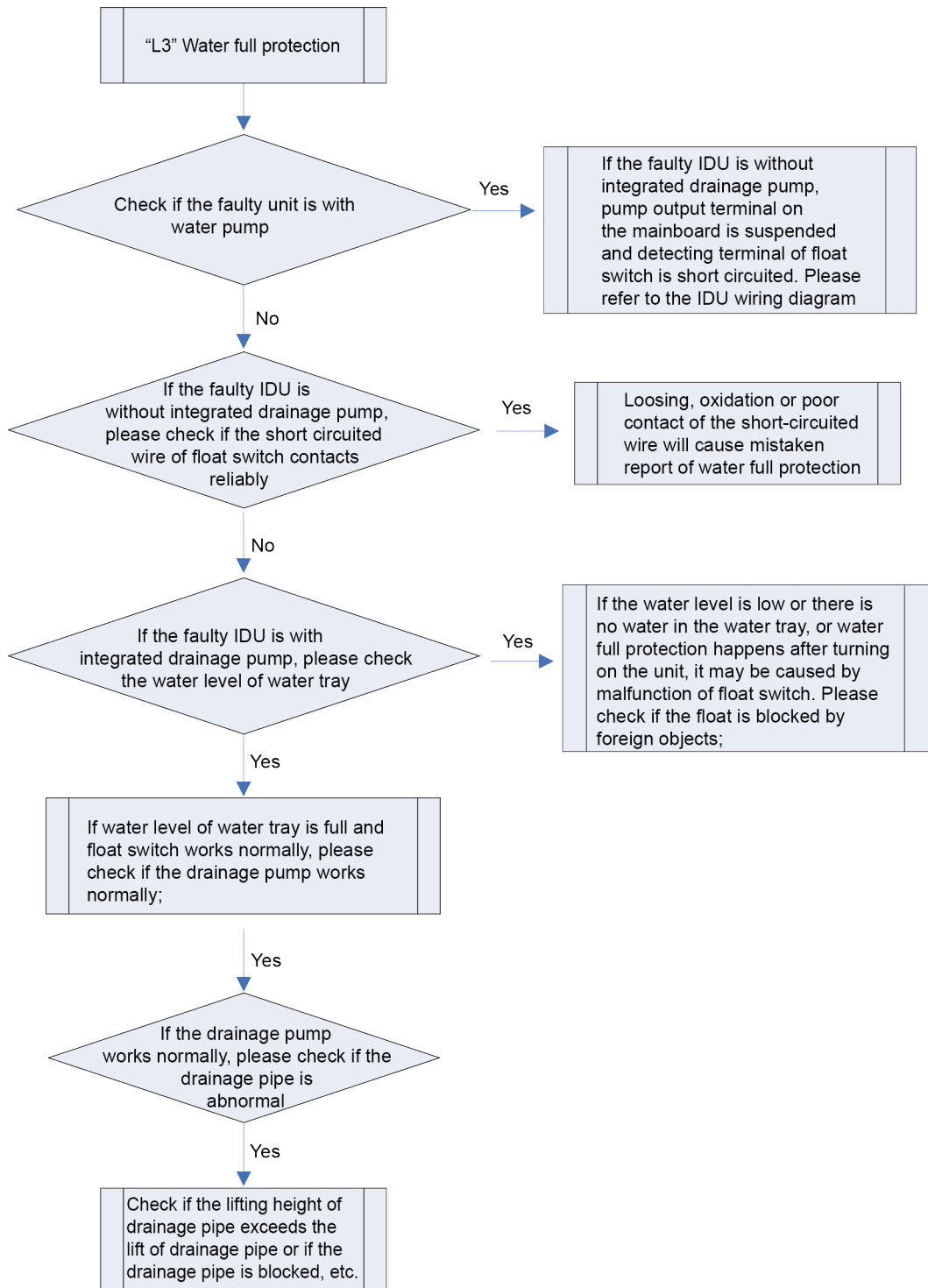

1.2.14 “L4” Power supply overcurrent protection

Error display: IDU wired controller and IDU receive light board will display



Error judgment condition and method:

Check if the power supply current from IDU to wired controller is normal. If power supply current is too big, it is judged that the current is abnormal.

Possible reason:

- Power supply conducting wire of wired controller is short circuited
- IDU mainboard is abnormal
- Mainboard of wired controller is abnormal

Troubleshooting:

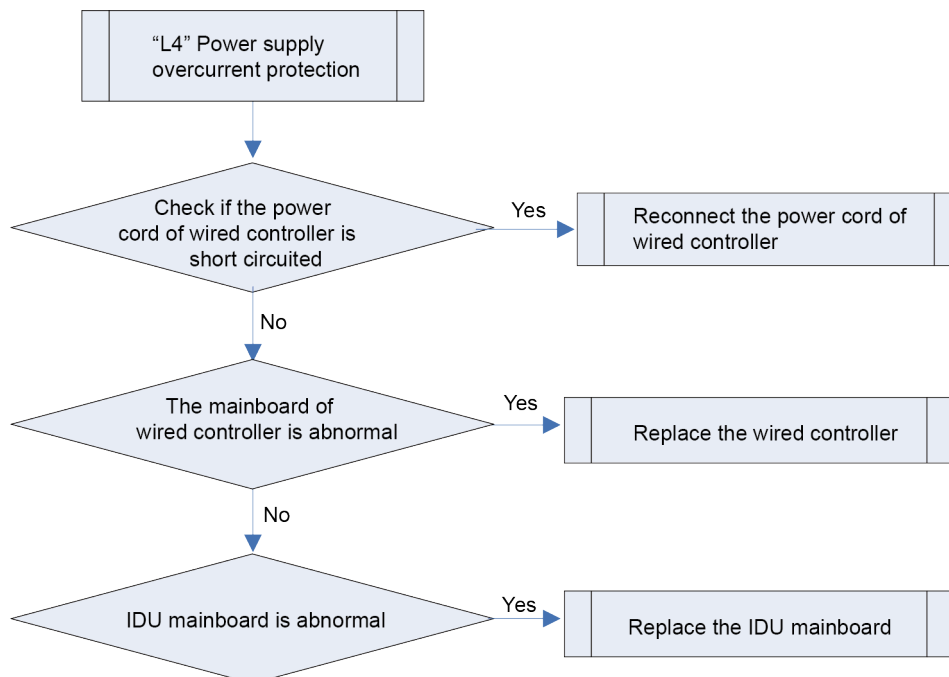

1.2.15 “L5” Freeze protection

Error display: IDU wired controller and IDU receive light board will display



Error judgment condition and method:

Check IDU pipe temperature. When pipe temperature is too low, freeze protection will be activated to prevent freezing damage of evaporator.

Possible reason:

- IDU filter and evaporator are dirty
- IDU motor is blocked
- Refrigerant amount is insufficient
- Ambient temperature of IDU and ODU is too low

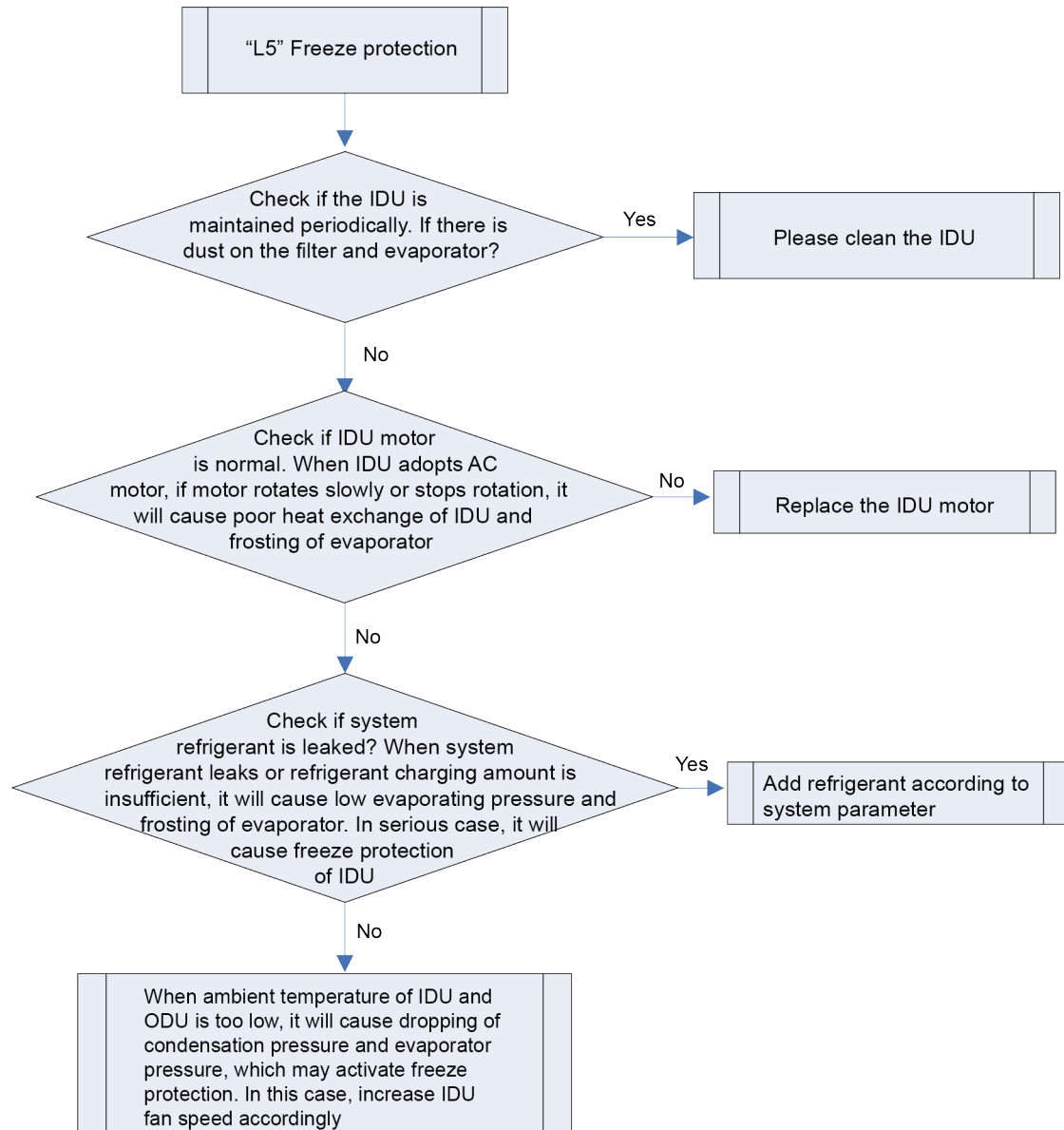
Troubleshooting:**1.2.16 "L7" No master IDU**

Error display: IDU wired controller and IDU receive light board will display



Error judgment condition and method:

No master IDU error will happen when there is no master IDU in the system.

Possible reason:

- Master IDU is offline
- The mainboard of master IDU is replaced
- The mainboard of master IDU has error

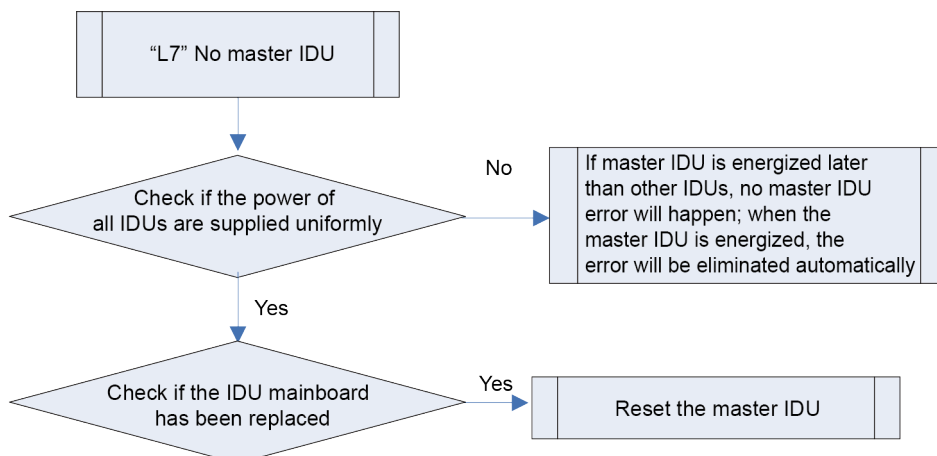
Troubleshooting:**1.2.17 “L9” Group-controlled IDU quantity inconsistency**

Error display: IDU wired controller and IDU receive light board will display

**Error judgment condition and method:**

If the IDU quantity connected with wired controller exceeds 16 sets or actually connected IDU quantity is inconsistent with the set group-controlled IDU quantity.

Possible reason:

- IDU quantity connected with one wired controller exceeds 16 sets;
- Actually connected IDU quantity is inconsistent with the set group-controlled IDU quantity.

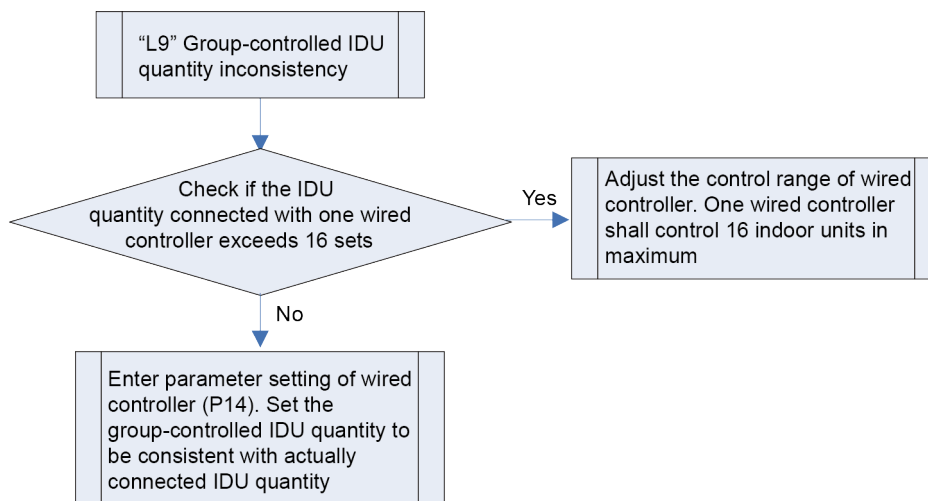
Troubleshooting:**1.2.18 “LA” Group-controlled IDU series inconsistency**

Error display: IDU wired controller and IDU receive light board will display

**Error judgment condition and method:**

Wired controller detects that the IDUs connected with itself belong to different series.

Possible reason:

- IDUs connected with one wired controller belong to different series.

Troubleshooting:

Make sure the IDUs connected with one wired controller belong to the same series.

1.2.19 “LC” Mismatch of IDU and ODU models

Error display: IDU wired controller and IDU receive light board will display

**Error judgment condition and method:**

When some IDUs or devices which cannot be identified by some ODUs are installed in the system, mismatch error of IDU and ODU models will occur.

Possible reason:

- Mismatch of IDU and ODU

Troubleshooting:

When some IDUs or devices which cannot be identified by some ODUs are installed in the system (E.g. floor heating device is installed in modular DC inverter multiple VRF system), the error will occur. Please remove the relevant IDU devices or replace the ODU with suitable model.

2 After-sales Emergency Measures

When some unrecoverable fault occurs to one module which is connected with several others in parallel, the following emergency measures are recommended to guarantee the heating or cooling capacity of the indoor units and the service life of modules except the faulted one are not affected.

Step 1: set all indoor units under “Off” mode and cut off the power supply to the indoor and outdoor units.

Step 2: shut off all cutoff valves of the faulted outdoor unit, including the cutoff valves of the liquid/gas pipe as well as the oil balancing valve.

Step 3: cut off the air switch of the module.

Step 4: remove the communication line between the faulted module and other modules which are still kept connected through the communication line.

Step 5: readjust the address and quantity settings on the main board of the modules except the faulted one.

Step 6: power and restart the unit.

3 Wiring Diagram

NOTE:

This drawing is just for reference; please always refer to the electric wiring stuck to the unit for actual wiring.

3.1 Floor Standing Type

GMV-ND100L/A-T, GMV-ND140L/A-T:

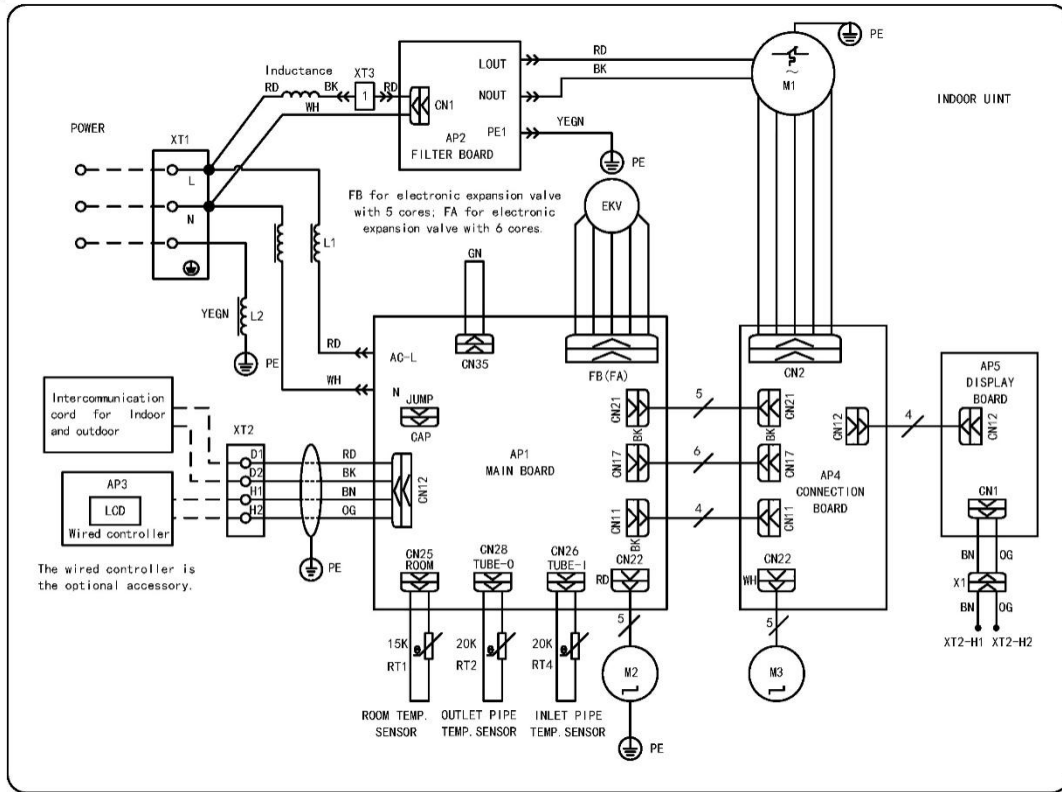

3.2 High Static Pressure Duct Type

GMV-ND56PHS/A-T, GMV-ND63PHS/A-T, GMV-ND71PHS/A-T, GMV-ND80PHS/A-T, GMV-ND90PHS/A-T, GMV-ND100PHS/A-T, GMV-ND112PHS/A-T, GMV-ND125PHS/A-T, GMV-ND140PHS/A-T:

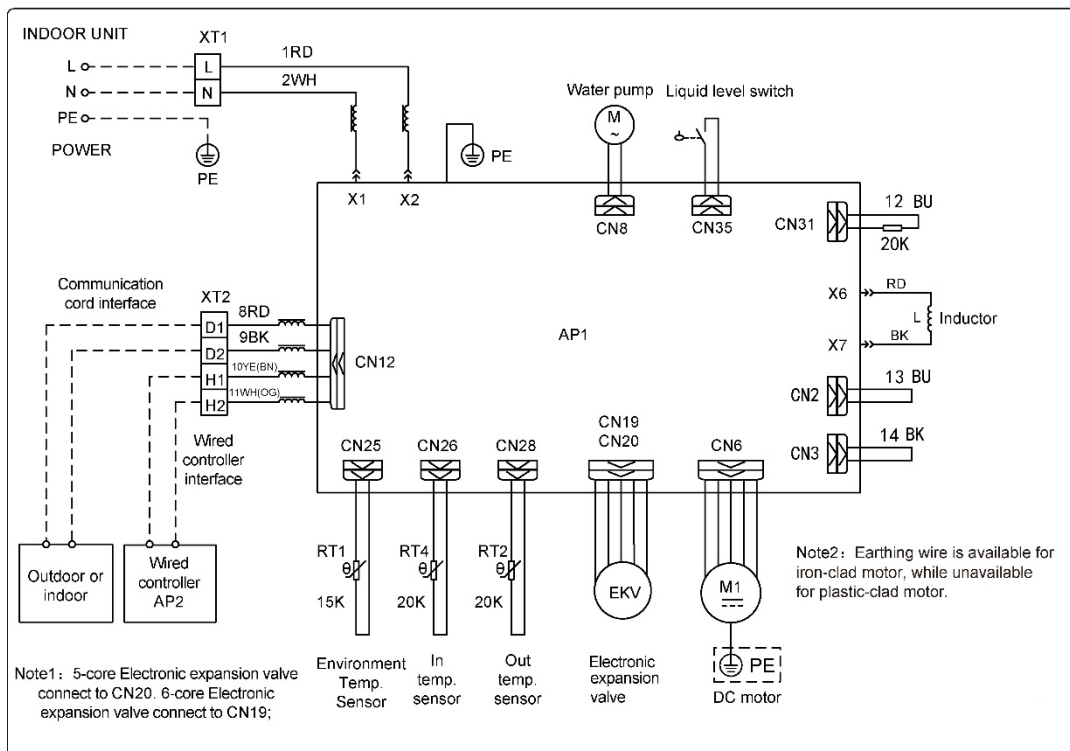

GMV-ND160PHS/A-T:

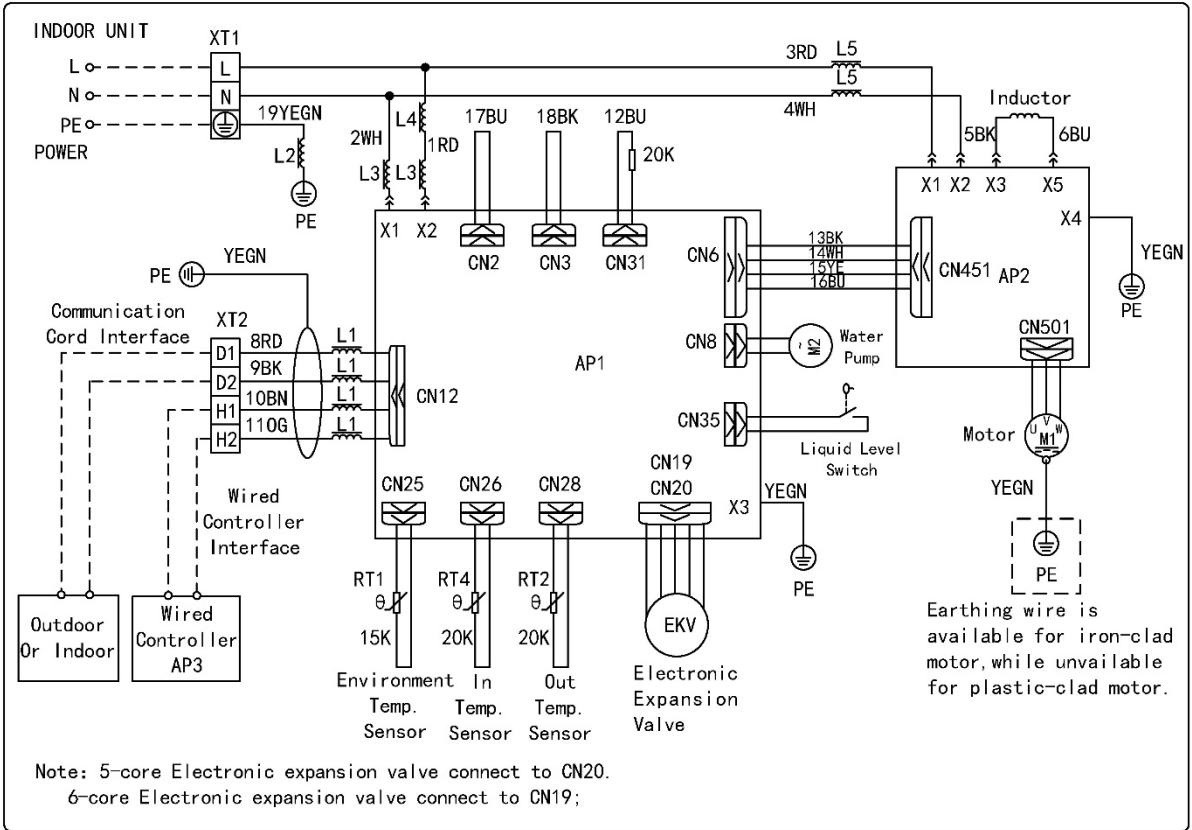

GMV-ND224PH/A-T, GMV-ND280PH/A-T:

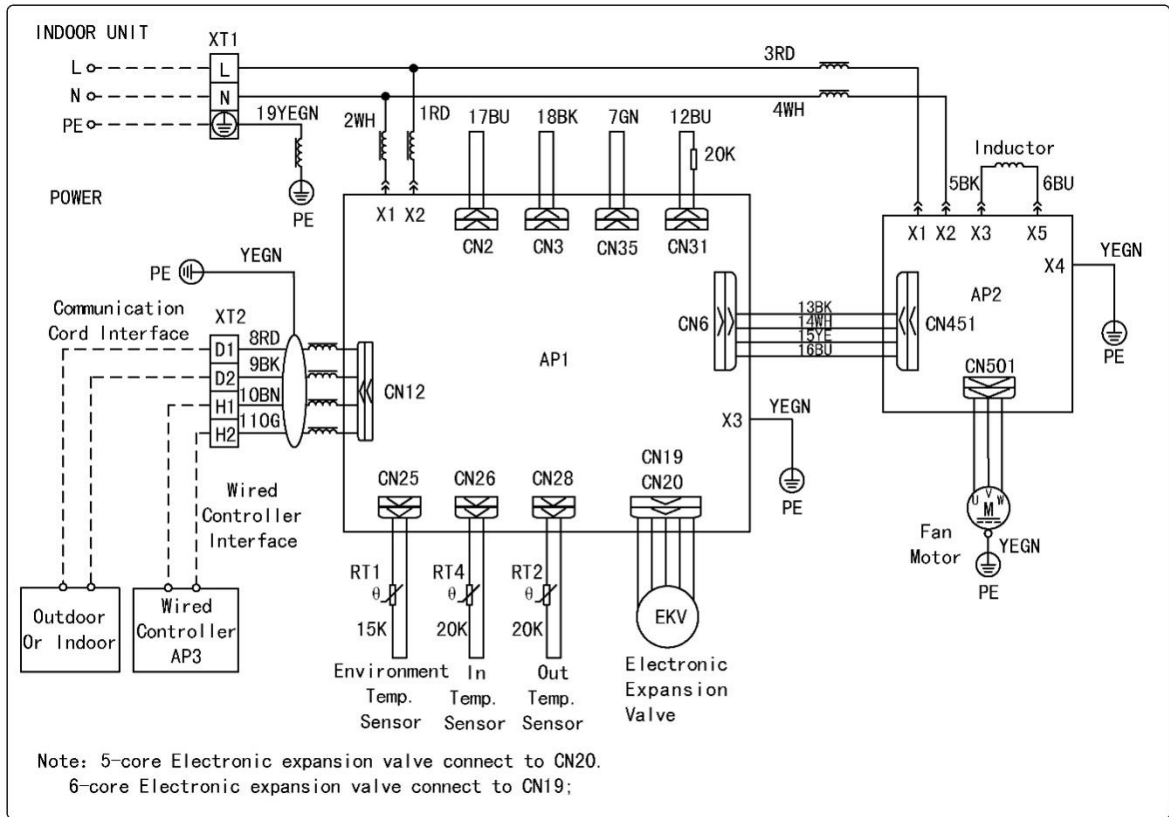

3.3 Low Static Pressure Duct Type

GMV-ND22PLS/A-T, GMV-ND25PLS/A-T, GMV-ND28PLS/A-T, GMV-ND32PLS/A-T, GMV-ND36PLS/A-T, GMV-ND40PLS/A-T, GMV-ND45PLS/A-T, GMV-ND50PLS/A-T, GMV-ND56PLS/A-T, GMV-ND63PLS/A-T, GMV-ND71PLS/A-T, GMV-ND80PLS/A-T:

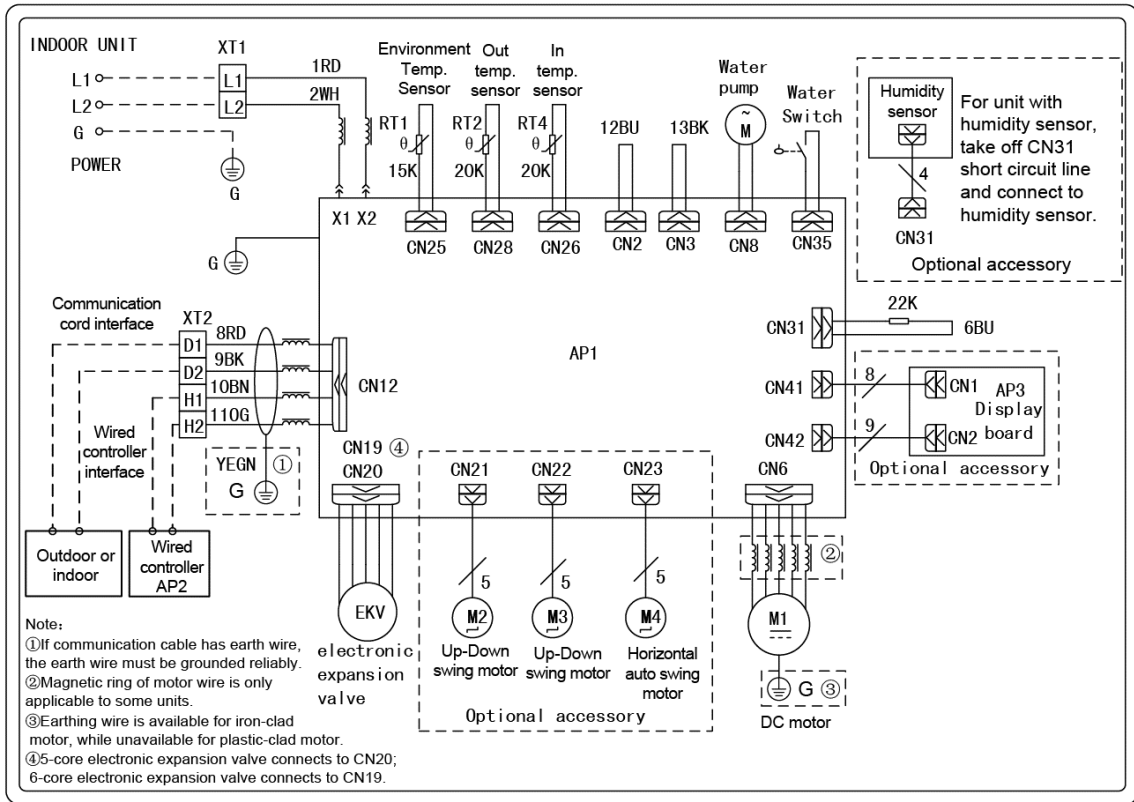

GMV-ND90PLS/A-T, GMV-ND100PLS/A-T, GMV-ND112PLS/A-T, GMV-ND125PLS/A-T, GMV-ND140PLS/A-T:

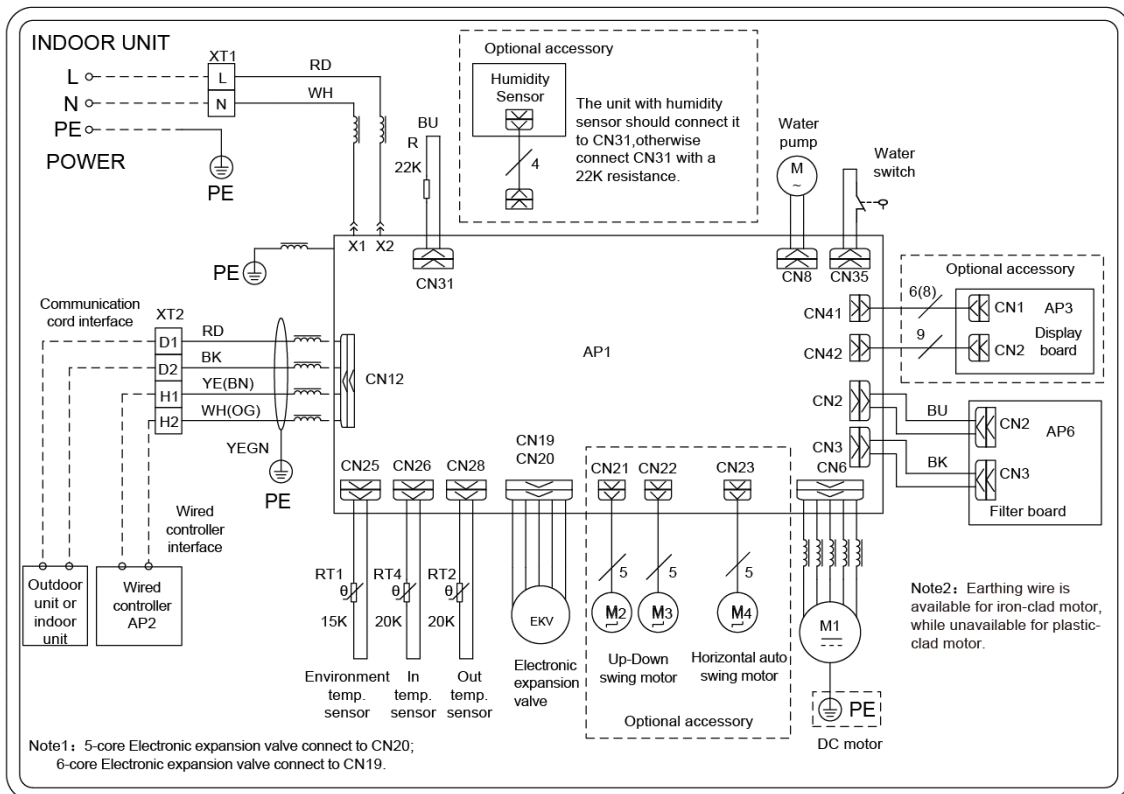

GMV-ND18PLS/C-T, GMV-ND22PLS/C-T, GMV-ND25PLS/C-T, GMV-ND28PLS/C-T,

GMV-ND32PLS/C-T, GMV-ND36PLS/C-T, GMV-ND40PLS/C-T, GMV-ND45PLS/C-T,
 GMV-ND50PLS/C-T, GMV-ND56PLS/C-T, GMV-ND63PLS/C-T, GMV-ND71PLS/C-T:

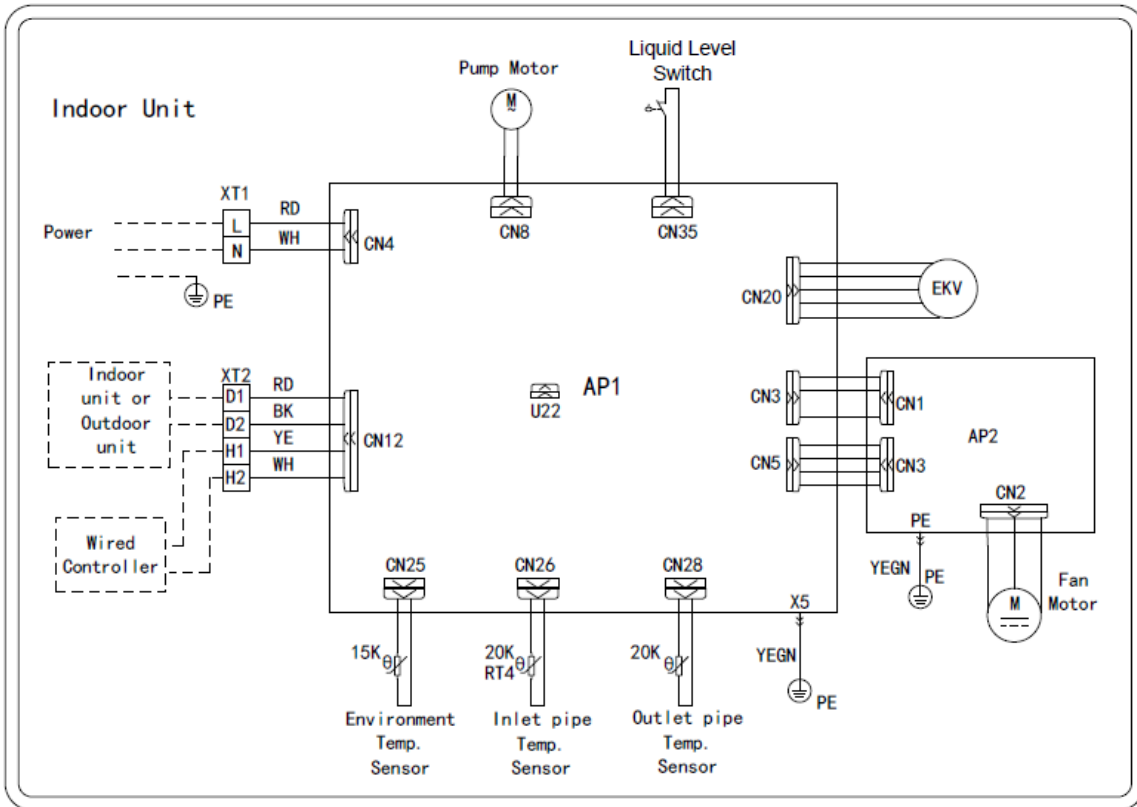

GMV-ND80PLS/C-T:

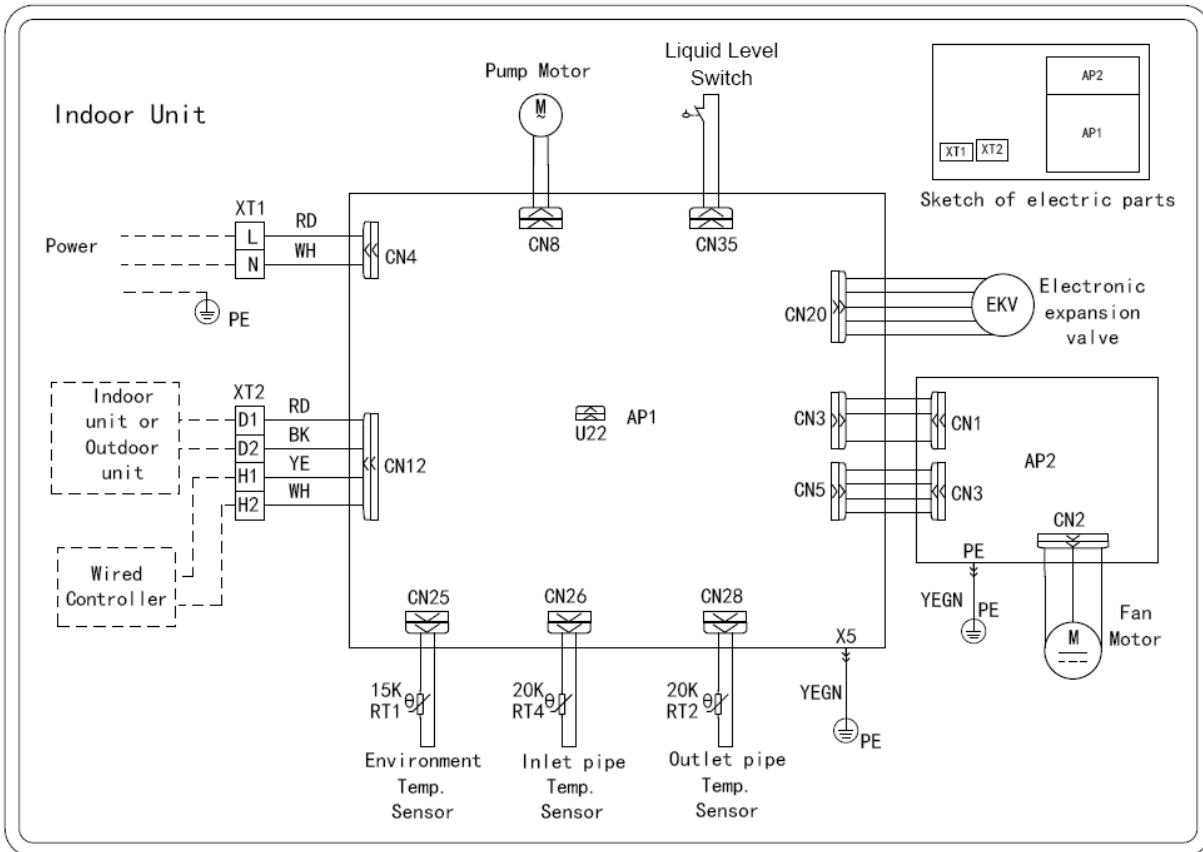

GMV-ND90PLS/C-T, GMV-ND100PLS/C-T, GMV-ND112PLS/C-T, GMV-ND125PLS/C-T, GMV-ND140PLS/C-T:

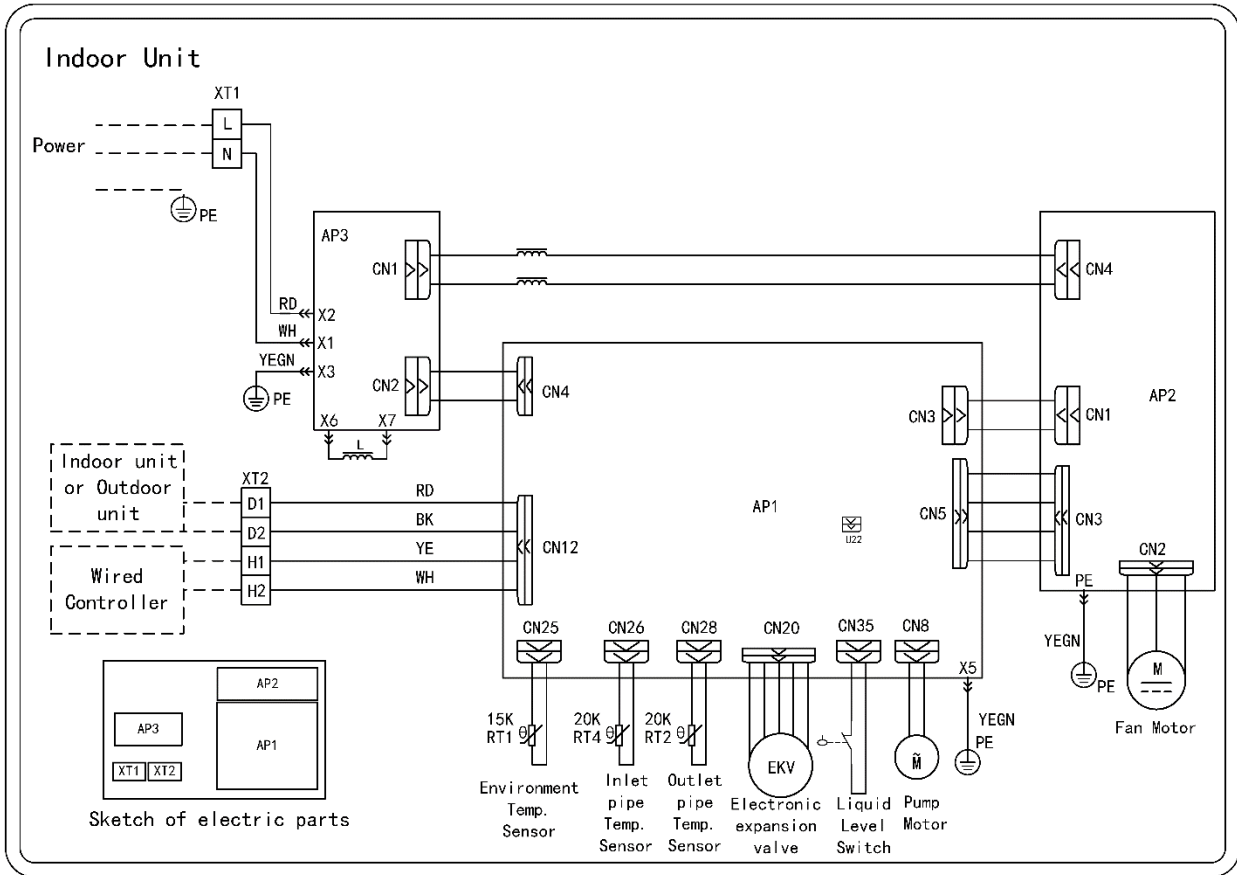

3.4 4-way Cassette Type

GMV-ND28T/A-T, GMV-ND36T/A-T, GMV-ND45T/A-T, GMV-ND50T/A-T, GMV-ND56T/A-T, GMV-ND63T/A-T, GMV-ND71T/A-T, GMV-ND80T/A-T:

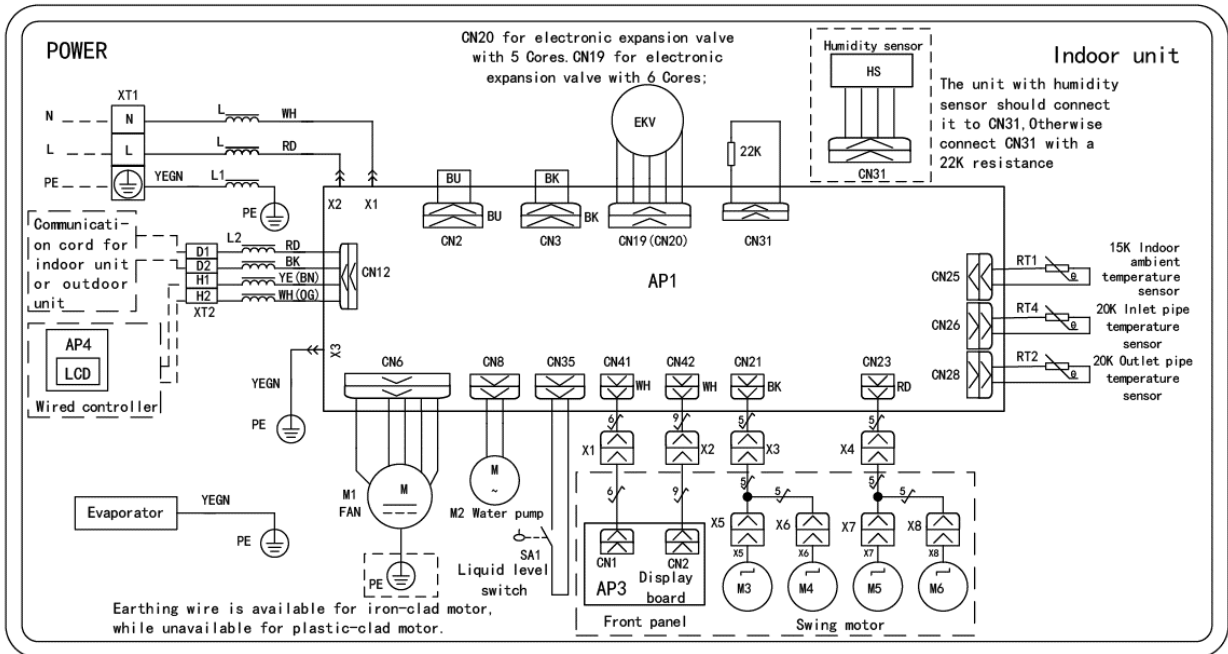

GMV-ND90T/A-T, GMV-ND100T/A-T, GMV-ND112T/A-T, GMV-ND125T/A-T, GMV-ND140T/A-T:

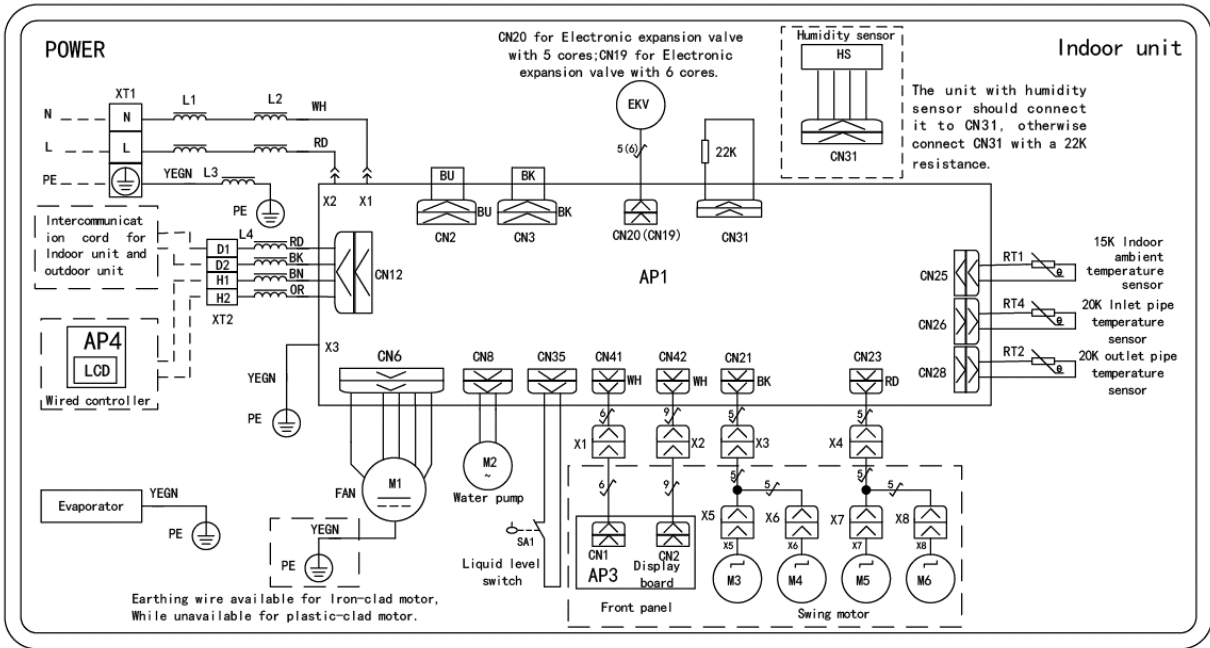

GMV-ND160T/A-T:

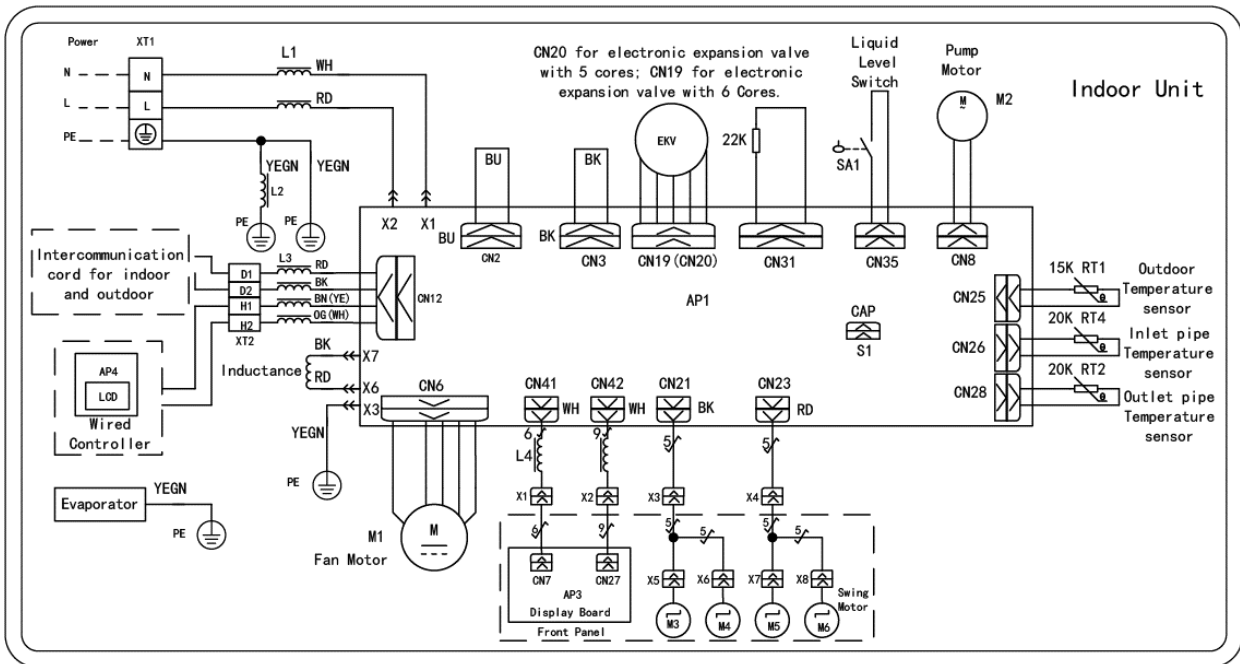

3.6 360° Air Discharge Compact Cassette Type

GMV-ND15T/E-T, GMV-ND18T/E-T, GMV-ND22T/E-T, GMV-ND28T/E-T, GMV-ND36T/E-T, GMV-ND45T/E-T, GMV-ND50T/E-T, GMV-ND56T/E-T

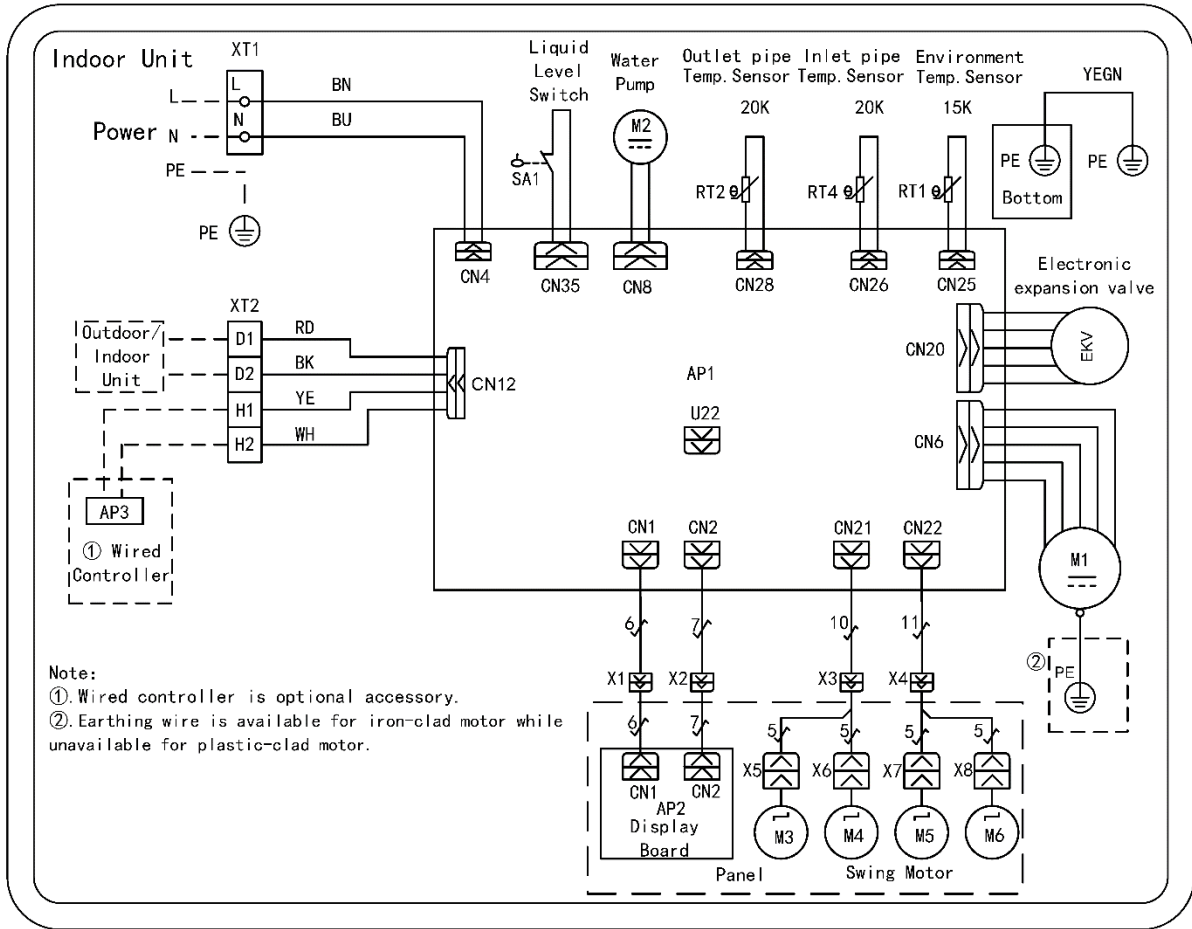

3.7 2-way Cassette Type

GMV-ND28TS/A-T, GMV-ND36TS/A-T, GMV-ND45TS/A-T, GMV-ND50TS/A-T, GMV-ND56TS/A-T, GMV-ND63TS/A-T, GMV-ND71TS/A-T:

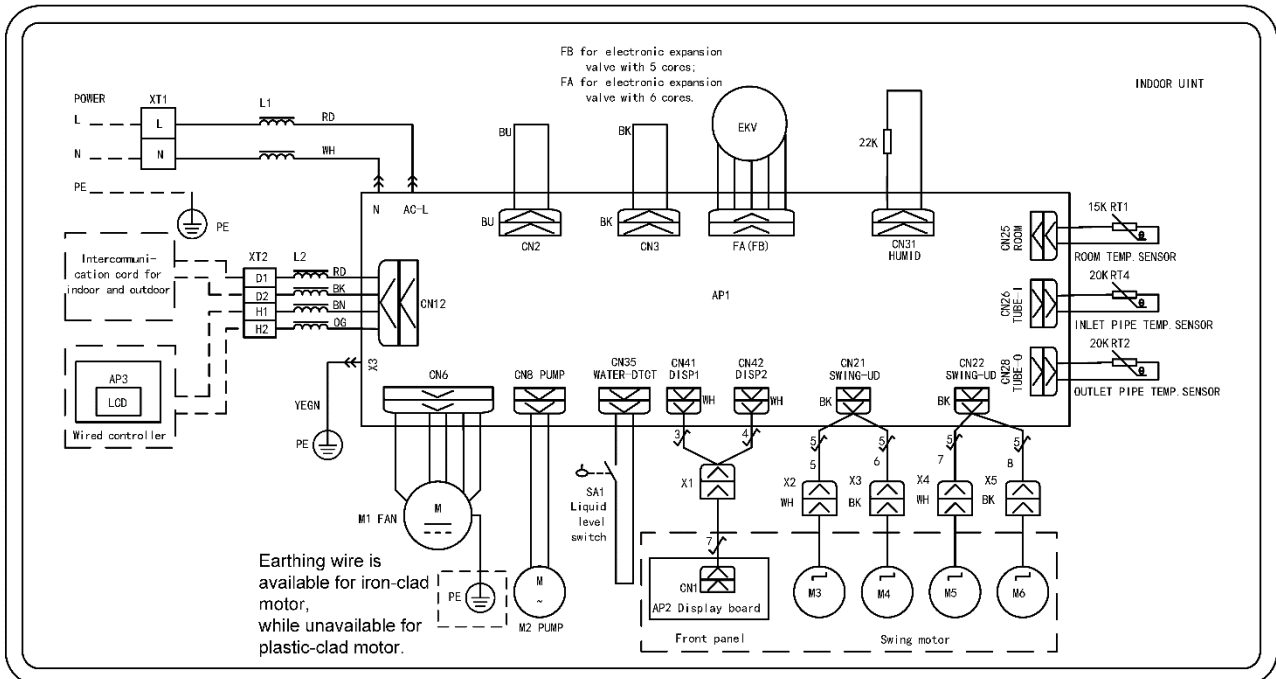

3.8 1-way Cassette Type

GMV-ND22TD/A-T, GMV-ND28TD/A-T, GMV-ND36TD/A-T, GMV-ND45TD/A-T, GMV-ND50TD/A-T, GMV-ND56TD/A-T:

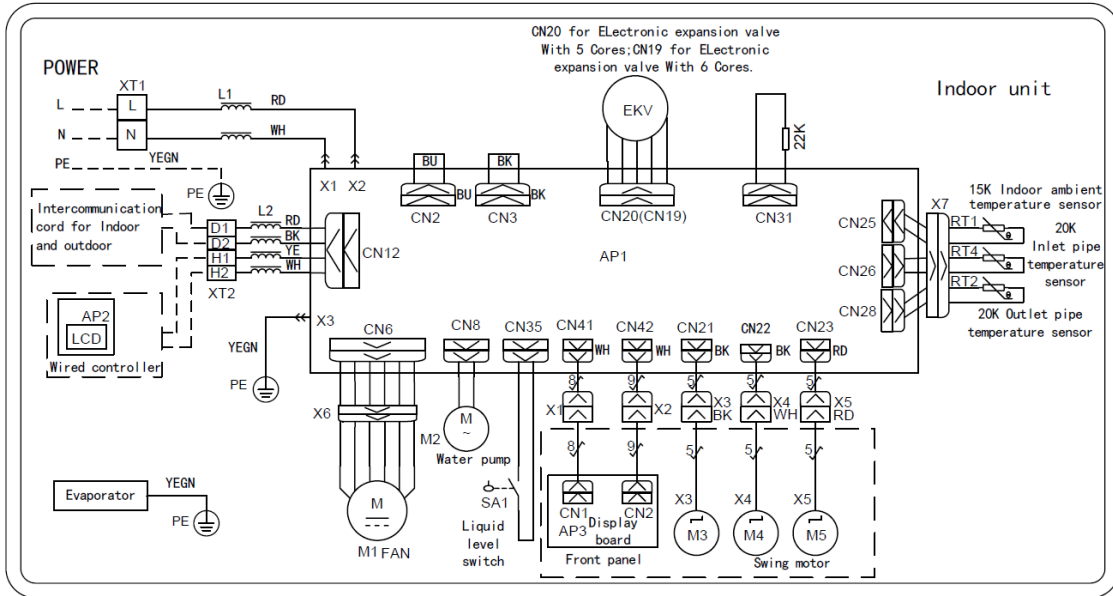

3.9 Floor Ceiling Type

GMV-ND28ZD/A-T, GMV-ND36ZD/A-T, GMV-ND50ZD/A-T, GMV-ND56ZD/A-T, GMV-ND63ZD/A-T, GMV-ND71ZD/A-T, GMV-ND90ZD/A-T, GMV-ND112ZD/A-T, GMV-ND125ZD/A-T, GMV-ND140ZD/A-T, GMV-ND160ZD/A-T:

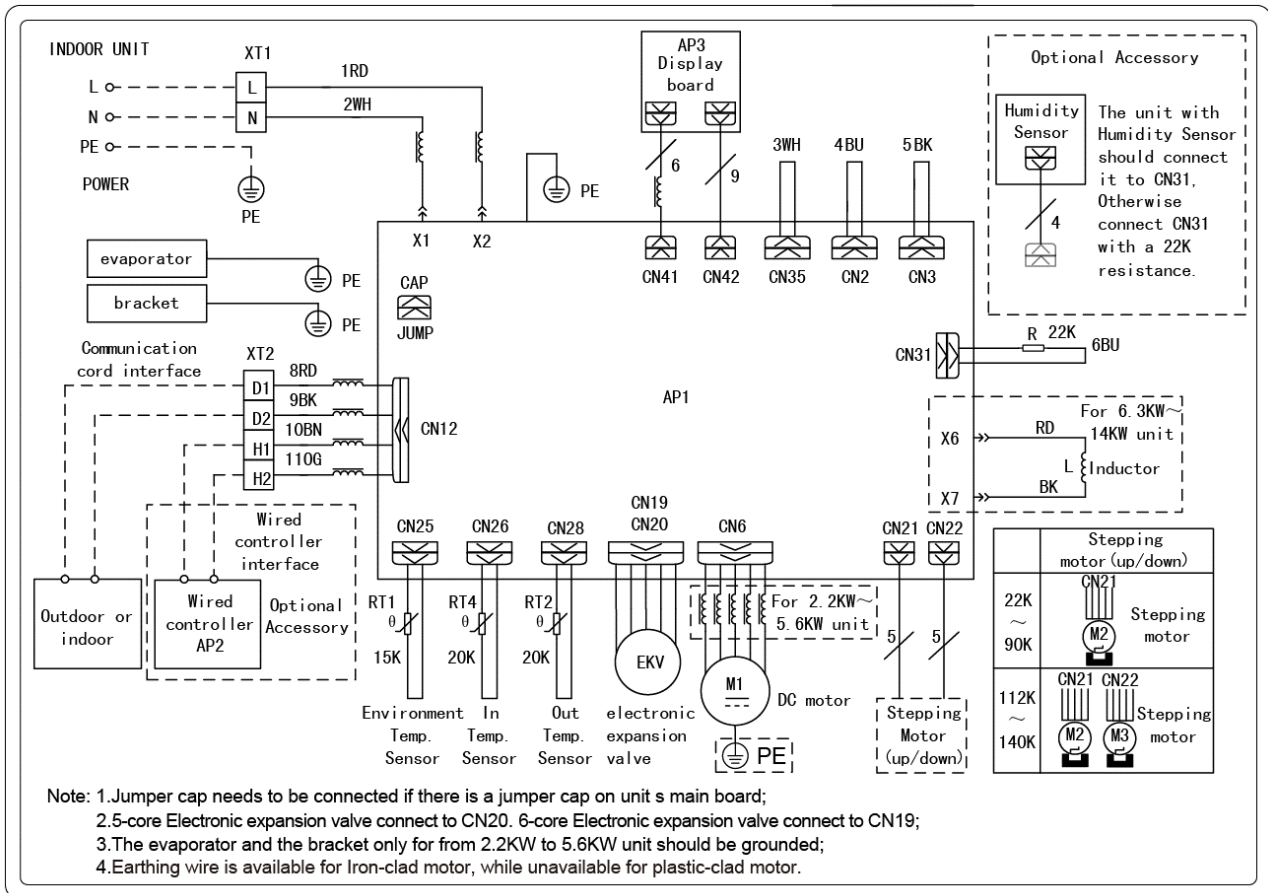

3.10 Fresh air Processing Unit

GMV-NX140P/A(X1.2)-K:

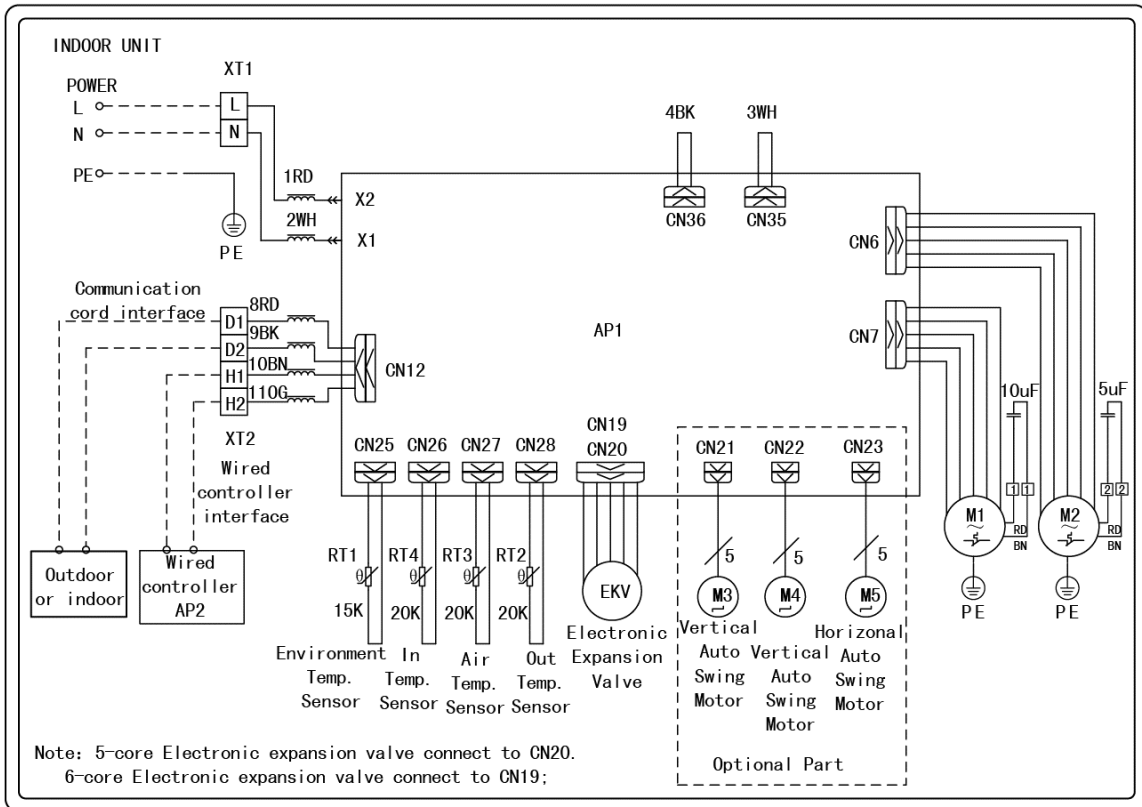

GMV-NX224P/A(X2.0)-M, GMV-NX280P/A(X2.5)-M, GMV-NX280P/A(X3.0)-M:

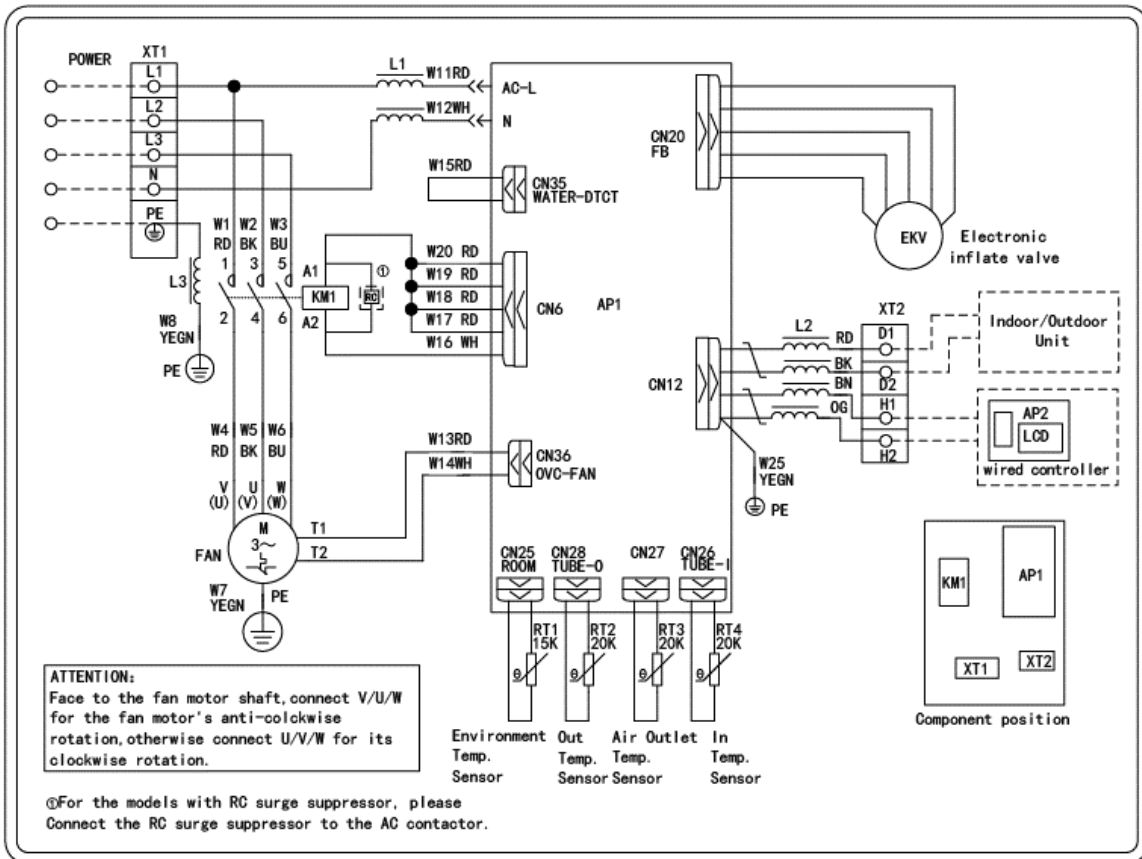

GMV-NX450P/A(X4.0)-M:

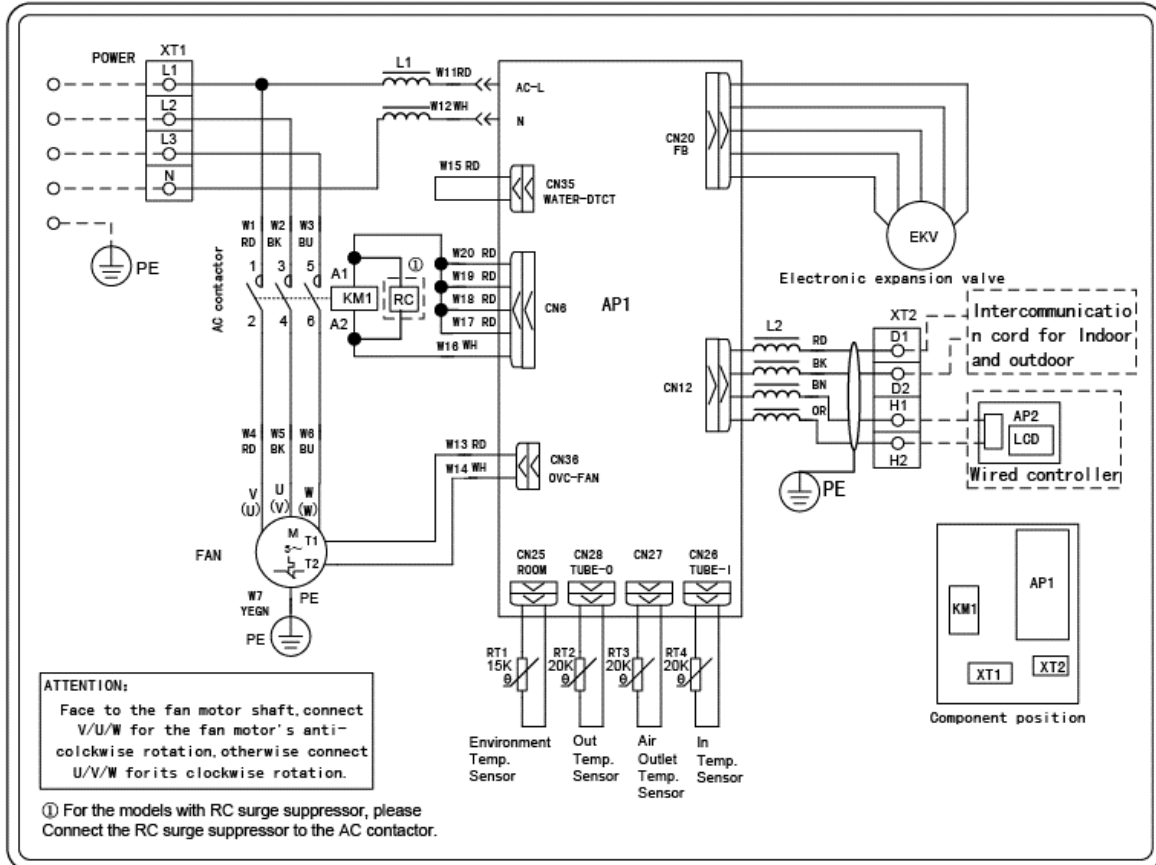

GMV-NDX125P/A-T, GMV-NDX140P/A-T:

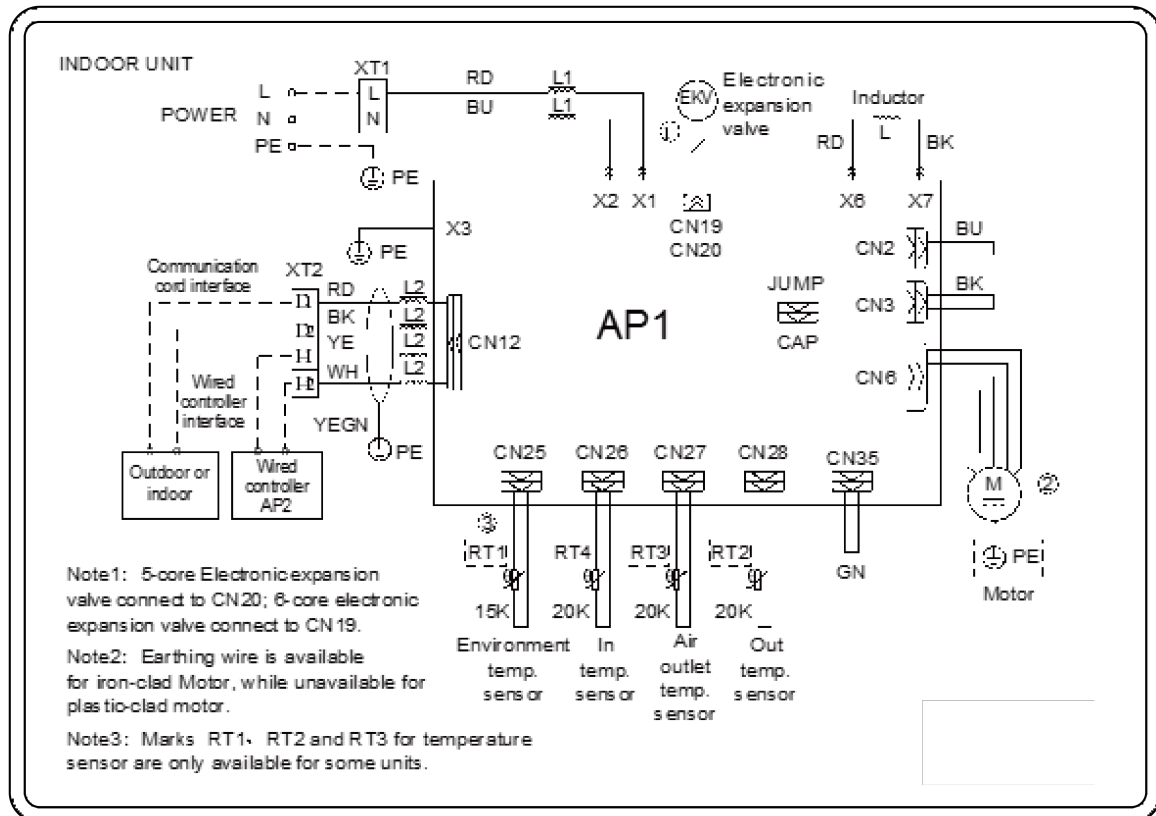

GMV-NDX224P/A-T, GMV-NDX250P/A-T, GMV-NDX280P/A-T:

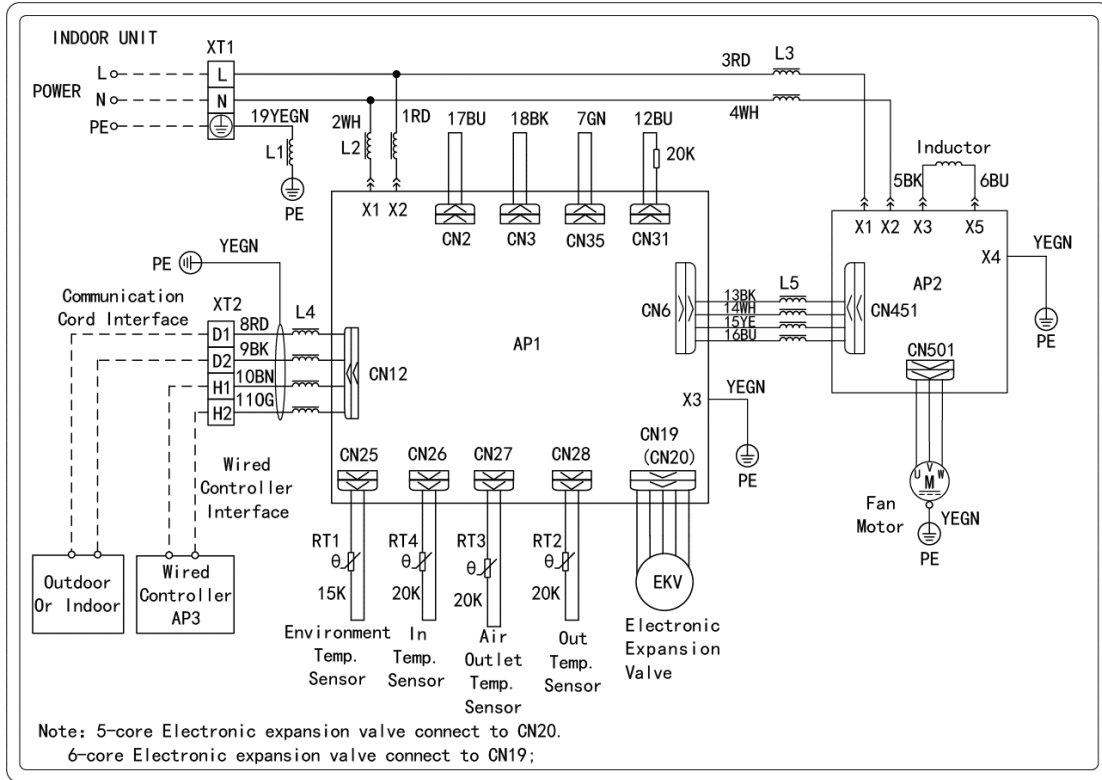

3.11 Slim Duct Type

GMV-ND22PL/B-T, GMV-ND25PL/B-T, GMV-ND28PL/B-T, GMV-ND32PL/B-T, GMV-ND36PL/B-T, GMV-ND40PL/B-T, GMV-ND45PL/B-T, GMV-ND50PL/B-T, GMV-ND56PL/B-T, GMV-ND63PL/B-T, GMV-ND72PL/B-T, GMV-ND22PLS/B1-T, GMV-ND25PLS/B1-T, GMV-ND28PLS/B1-T, GMV-ND32PLS/B1-T, GMV-ND36PLS/B1-T, GMV-ND40PLS/B1-T, GMV-ND45PLS/B1-T, GMV-ND50PLS/B1-T, GMV-ND56PLS/B1-T, GMV-ND63PLS/B1-T, GMV-ND71PLS/B1-T:

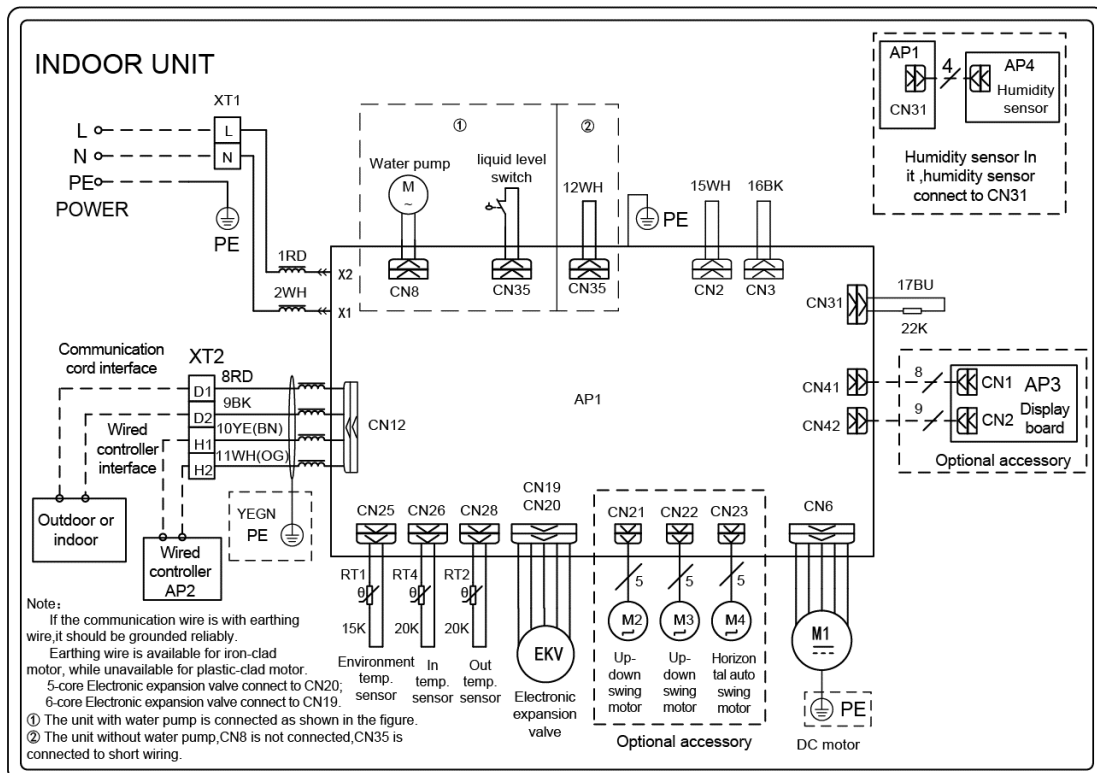

3.12 Air Handler Type Indoor Unit

GMV-NR71A/A-D, GMV-NR90A/A-D, GMV-NR100A/A-D, GMV-NR112A/A-D, GMV-NR140A/A-D:

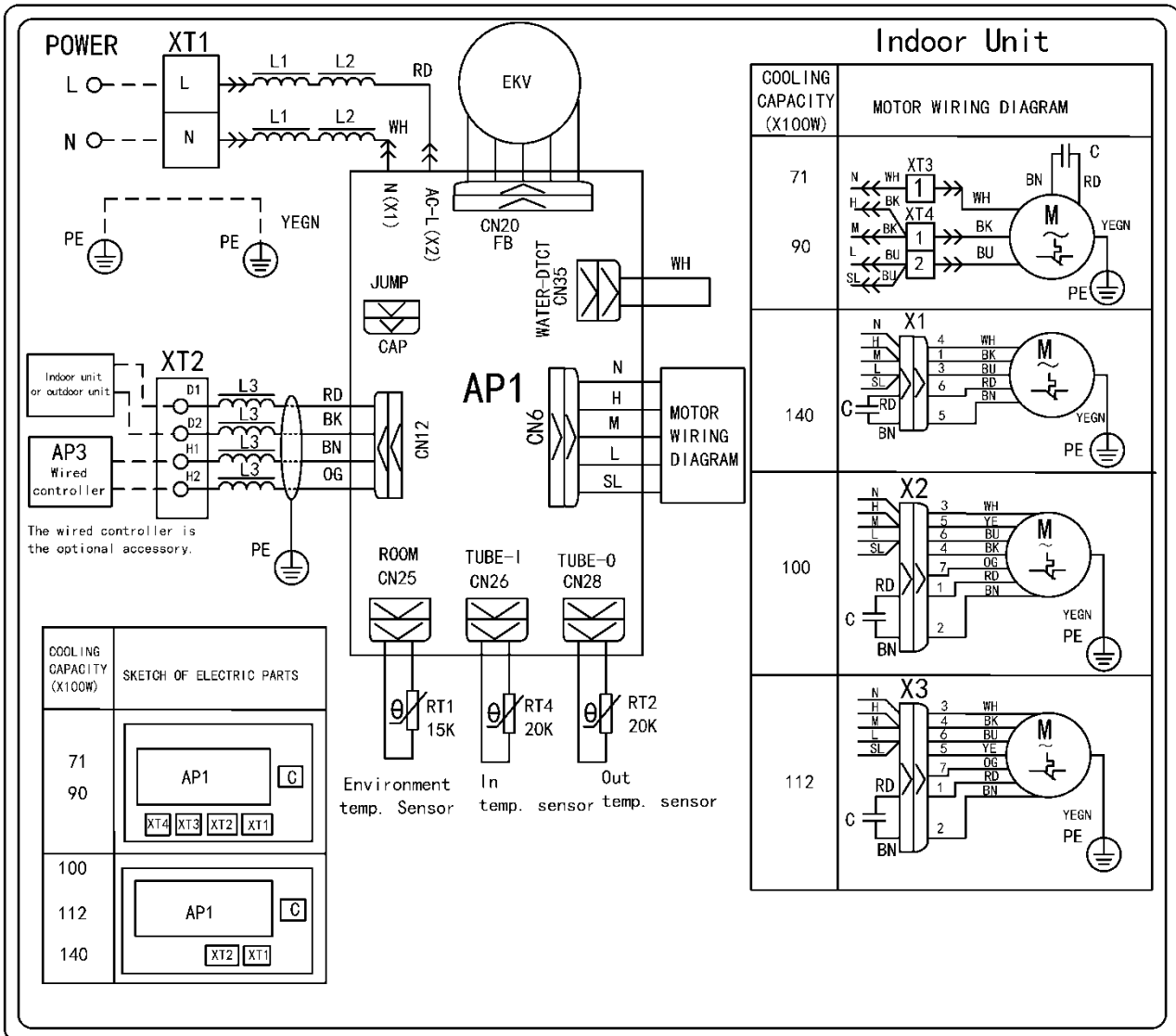

COOLING CAPACITY (X100W)	MOTOR WIRING DIAGRAM
71 90	
140	
100	
112	

COOLING CAPACITY (X100W)	SKETCH OF ELECTRIC PARTS
71 90	
100	
112	
140	

3.13 Console Type Indoor Unit

GMV-ND22C/A-T, GMV-ND28C/A-T, GMV-ND36C/A-T, GMV-ND45C/A-T, GMV-ND50C/A-T:

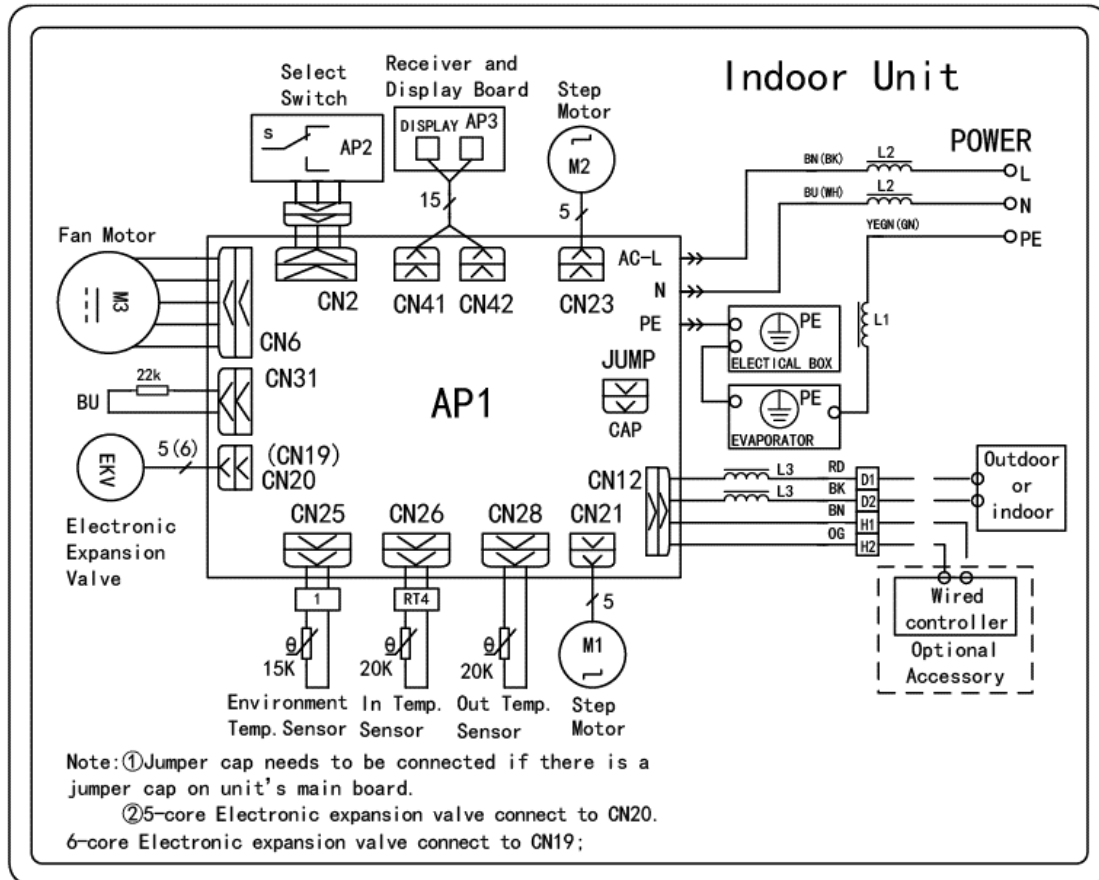

3.14 Wall Mounted type Indoor Unit

GMV-N22G/A3A-K, GMV-N28G/A3A-K, GMV-N36G/A3A-K, GMV-N45G/A3A-K, GMV-N50G/A3A-K,
GMV-N56G/A3A-K, GMV-N63G/A3A-K, GMV-N71G/A3A-K;

GMV-N22G/B3A-K, GMV-N28G/B3A-K, GMV-N36G/B3A-K, GMV-N45G/B3A-K, GMV-N50G/B3A-K,
GMV-N56G/B3A-K, GMV-N63G/B3A-K, GMV-N71G/B3A-K;

GMV-N22G/A2A-K, GMV-N28G/A2A-K, GMV-N36G/A2A-K, GMV-N45G/A2A-K,
GMV-N50G/A2A-K, GMV-N56G/A2A-K, GMV-N63G/A2A-K, GMV-N71G/A2A-K;

GMV-N22G/A4A-K, GMV-N28G/A4A-K, GMV-N36G/A4A-K, GMV-N45G/A4A-K, GMV-N50G/A4A-K,
GMV-N56G/A4A-K, GMV-N63G/A4A-K, GMV-N71G/A4A-K;

GMV-N22G/A8A-K, GMV-N28G/A8A-K, GMV-N36G/A8A-K, GMV-N45G/A8A-K, GMV-N50G/A8A-K,
GMV-N56G/A8A-K, GMV-N63G/A8A-K, GMV-N71G/A8A-K;

GMV-N22G/C9A-K, GMV-N28G/C9A-K, GMV-N36G/C9A-K, GMV-N45G/C9A-K,
GMV-N50G/C9A-K, GMV-N56G/C9A-K, GMV-N63G/C9A-K, GMV-N71G/C9A-K;

GMV-N22G/E3A-K, GMV-N28G/E3A-K, GMV-N36G/E3A-K, GMV-N45G/E3A-K, GMV-N50G/E3A-K,
GMV-N56G/E3A-K, GMV-N63G/E3A-K, GMV-N71G/E3A-K;

GMV-N22G/A3A-D, GMV-N28G/A3A-D, GMV-N36G/A3A-D, GMV-N45G/A3A-D,
GMV-N50G/A3A-D, GMV-N56G/A3A-D, GMV-N63G/A3A-D, GMV-N71G/A3A-D;

GMV-N22G/A2A-D, GMV-N28G/A2A-D, GMV-N36G/A2A-D, GMV-N45G/A2A-D,
GMV-N50G/A2A-D, GMV-N56G/A2A-D, GMV-N63G/A2A-D, GMV-N71G/A2A-D;

GMV-N22G/A4A-D, GMV-N28G/A4A-D, GMV-N36G/A4A-D, GMV-N45G/A4A-D,
 GMV-N50G/A4A-D, GMV-N56G/A4A-D, GMV-N63G/A4A-D, GMV-N71G/A4A-D;

GMV-N22G/A8A-D, GMV-N28G/A8A-D, GMV-N36G/A8A-D, GMV-N45G/A8A-D,
 GMV-N50G/A8A-D, GMV-N56G/A8A-D, GMV-N63G/A8A-D, GMV-N71G/A8A-D;

GMV-N22G/C9A-D, GMV-N28G/C9A-D, GMV-N36G/C9A-D, GMV-N45G/C9A-D,
 GMV-N50G/C9A-D, GMV-N56G/C9A-D, GMV-N63G/C9A-D, GMV-N71G/C9A-D;

GMV-N22G/E3A-D, GMV-N28G/E3A-D, GMV-N36G/E3A-D, GMV-N45G/E3A-D,
 GMV-N50G/E3A-D, GMV-N56G/E3A-D, GMV-N63G/E3A-D, GMV-N71G/E3A-D;

GMV-N22G/B3A-D, GMV-N28G/B3A-D, GMV-N36G/B3A-D, GMV-N45G/B3A-D,
 GMV-N50G/B3A-D, GMV-N56G/B3A-D, GMV-N63G/B3A-D, GMV-N71G/B3A-D;

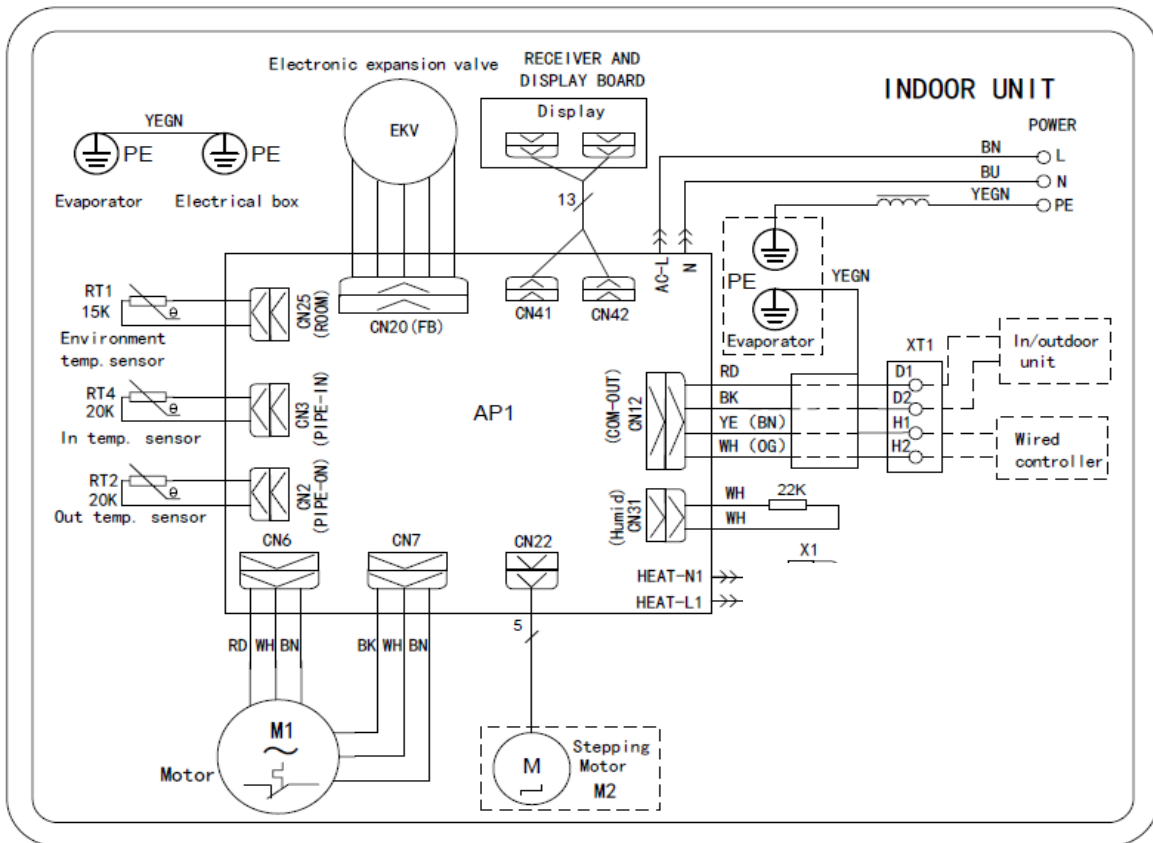

GMV-ND22G/A3A-T, GMV-ND28G/A3A-T, GMV-ND36G/A3A-T
 GMV-ND22G/A8A-T, GMV-ND28G/A8A-T, GMV-ND36G/A8A-T

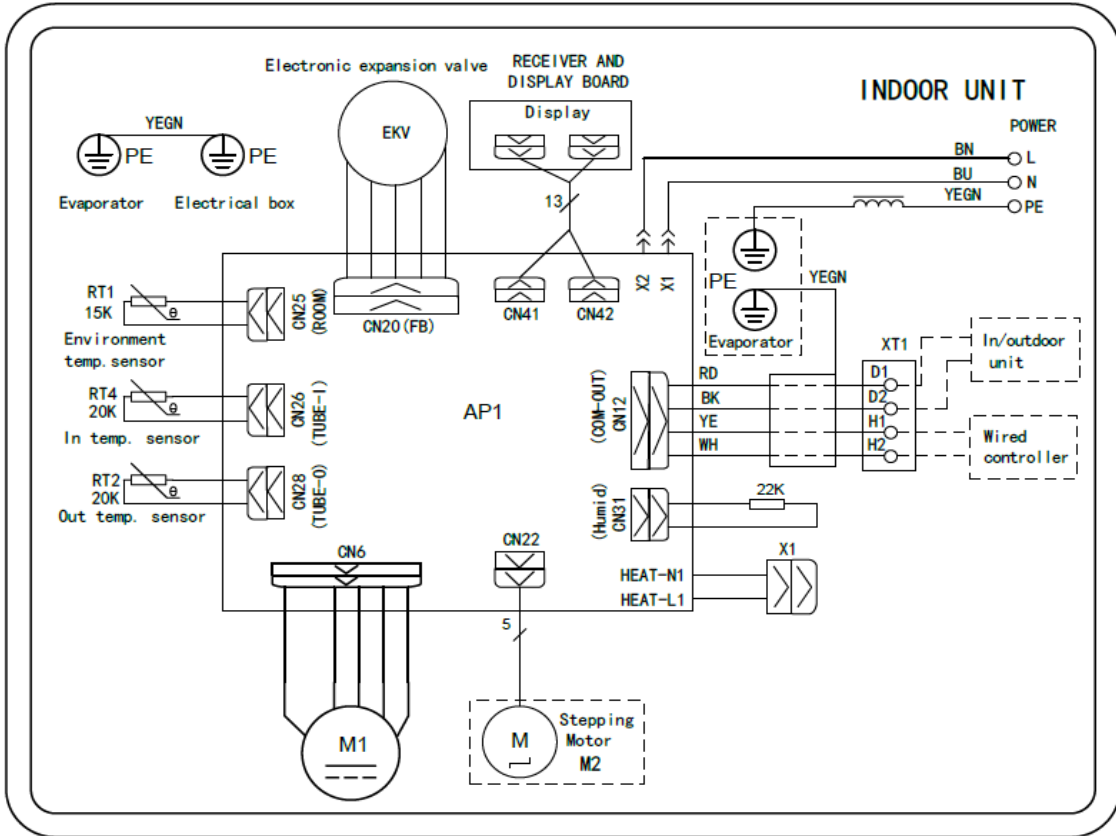

GMV-ND45G/A3A-T, GMV-ND50G/A3A-T, GMV-ND56G/A3A-T, GMV-ND63G/A3A-T,
 GMV-ND71G/A3A-T, GMV-ND45G/A8A-T, GMV-ND50G/A8A-T, GMV-ND56G/A8A-T,
 GMV-ND63G/A8A-T, GMV-ND71G/A8A-T

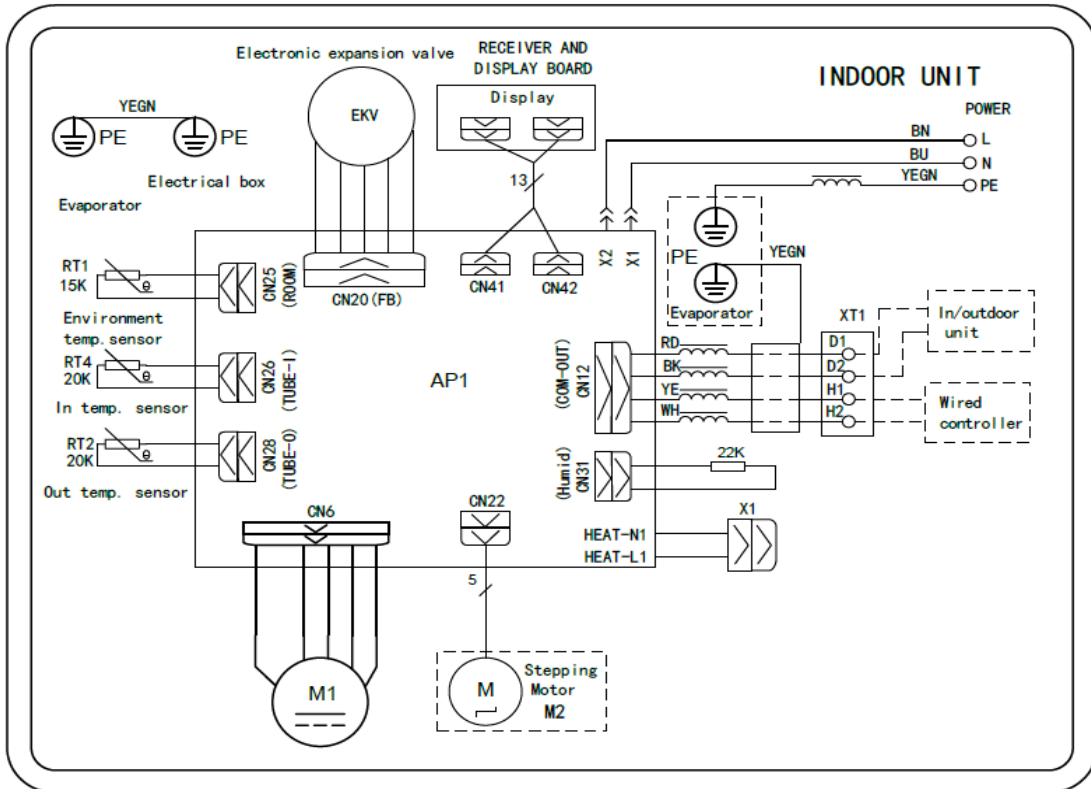

GMV-ND80G/A3A-T, GMV-ND90G/A3A-T, GMV-ND100G/A3A-T
 GMV-ND80G/A8A-T, GMV-ND90G/A8A-T, GMV-ND100G/A8A-T
 GMV-ND80G/B4B-T, GMV-ND90G/B4B-T, GMV-ND100G/B4B-T

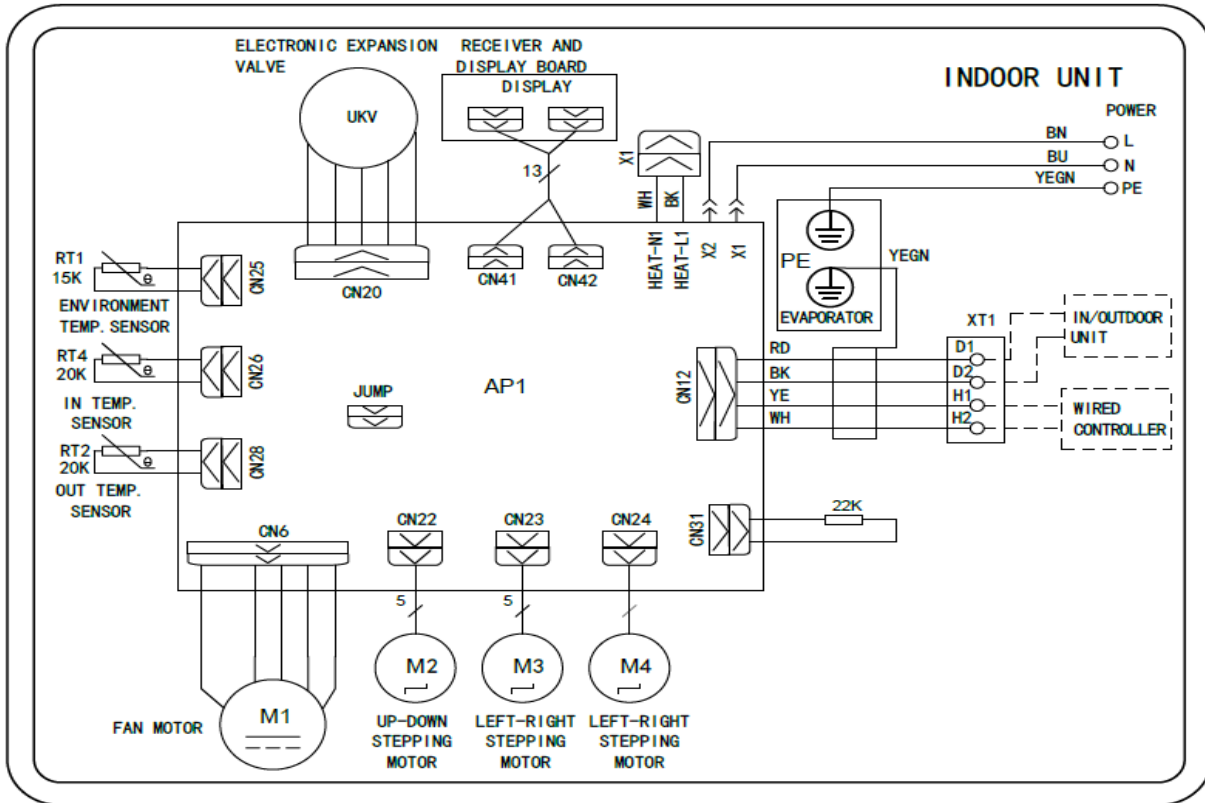

GMV-ND22G/B6B-T, GMV-ND28G/B6B-T, GMV-ND36G/B6B-T, GMV-ND45G/B6B-T, GMV-ND50G/B6B-T, GMV-ND56G/B6B-T, GMV-ND63G/B6B-T, GMV-ND71G/B6B-T

GMV-ND15G/B4B-T, GMV-ND18G/B4B-T, GMV-ND22G/B4B-T, GMV-ND28G/B4B-T, GMV-ND36G/B4B-T, GMV-ND45G/B4B-T, GMV-ND50G/B4B-T, GMV-ND56G/B4B-T, GMV-ND63G/B4B-T, GMV-ND71G/B4B-T

GMV-ND22G/C4B-T, GMV-ND28G/C4B-T, GMV-ND36G/C4B-T, GMV-ND45G/C4B-T, GMV-ND50G/C4B-T, GMV-ND56G/C4B-T, GMV-ND63G/C4B-T, GMV-ND71G/C4B-T

GMV-ND22G/C2B-T, GMV-ND28G/C2B-T, GMV-ND36G/C2B-T, GMV-ND45G/C2B-T, GMV-ND50G/C2B-T, GMV-ND56G/C2B-T, GMV-ND63G/C2B-T, GMV-ND71G/C2B-T

GMV-ND22G/D2B-T, GMV-ND28G/D2B-T, GMV-ND36G/D2B-T, GMV-ND45G/D2B-T, GMV-ND50G/D2B-T, GMV-ND56G/D2B-T, GMV-ND63G/D2B-T, GMV-ND71G/D2B-T

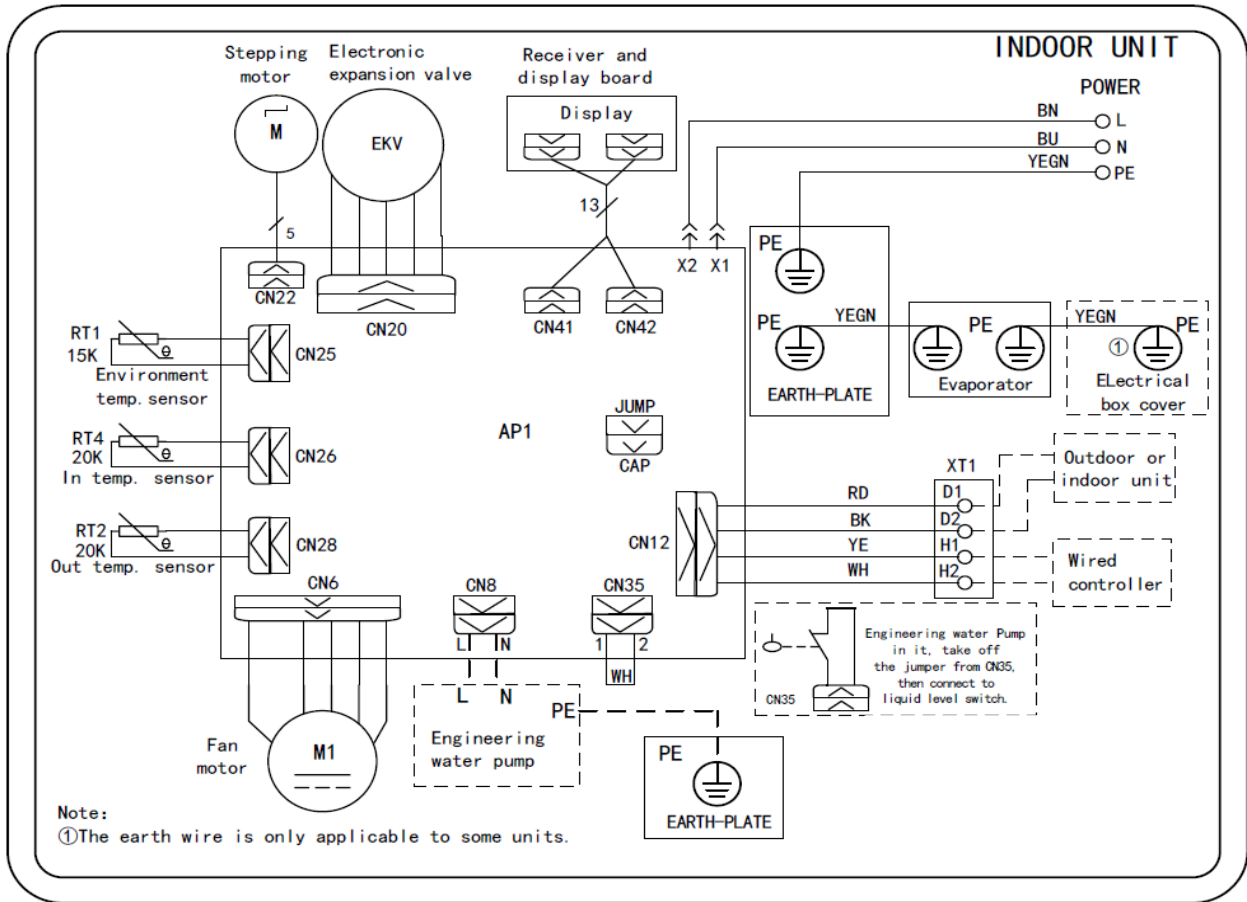

3.15 Super High Static Pressure Duct Type Indoor Unit

GMV-ND22PHS/B-T, GMV-ND25PHS/B-T, GMV-ND28PHS/B-T, GMV-ND32PHS/B-T,
 GMV-ND36PHS/B-T, GMV-ND40PHS/B-T, GMV-ND45PHS/B-T, GMV-ND50PHS/B-T,
 GMV-ND56PHS/B-T, GMV-ND63PHS/B-T, GMV-ND71PHS/B-T, GMV-ND80PHS/B-T:

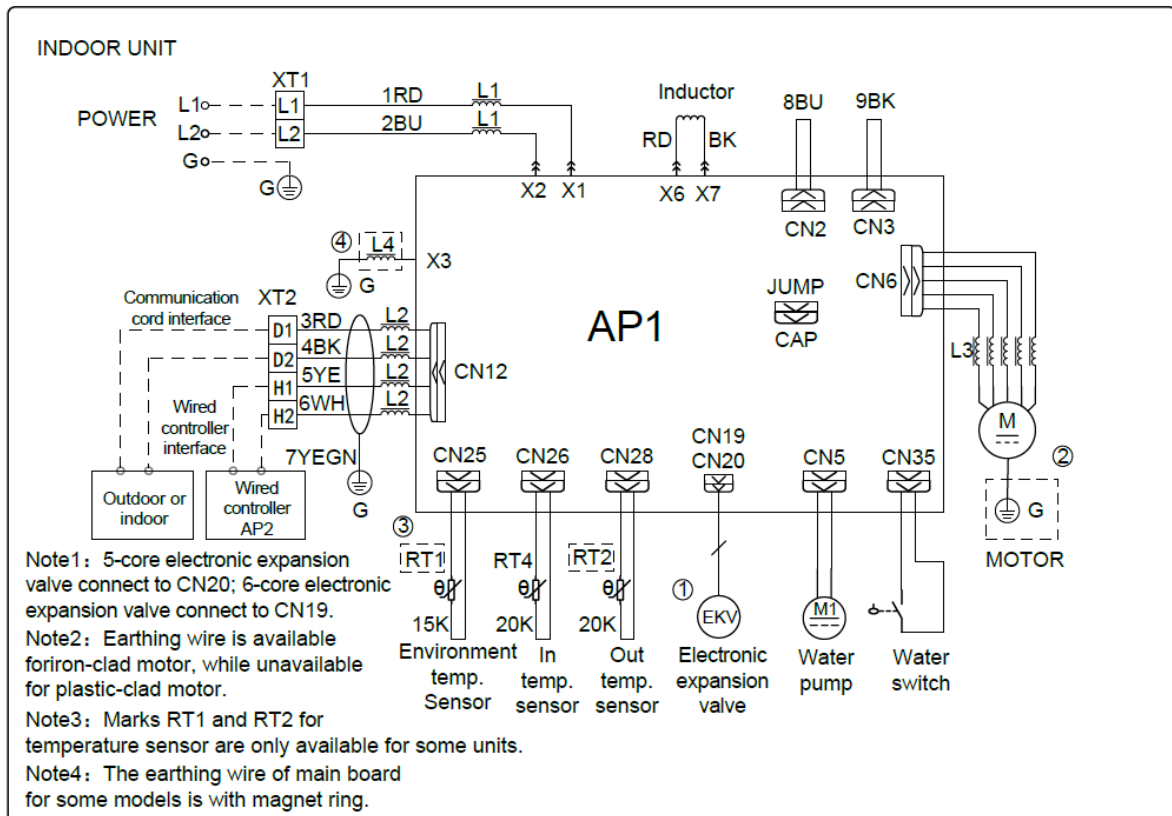

GMV-ND90PHS/B-T, GMV-ND100PHS/B-T, GMV-ND112PHS/B-T, GMV-ND125PHS/B-T:

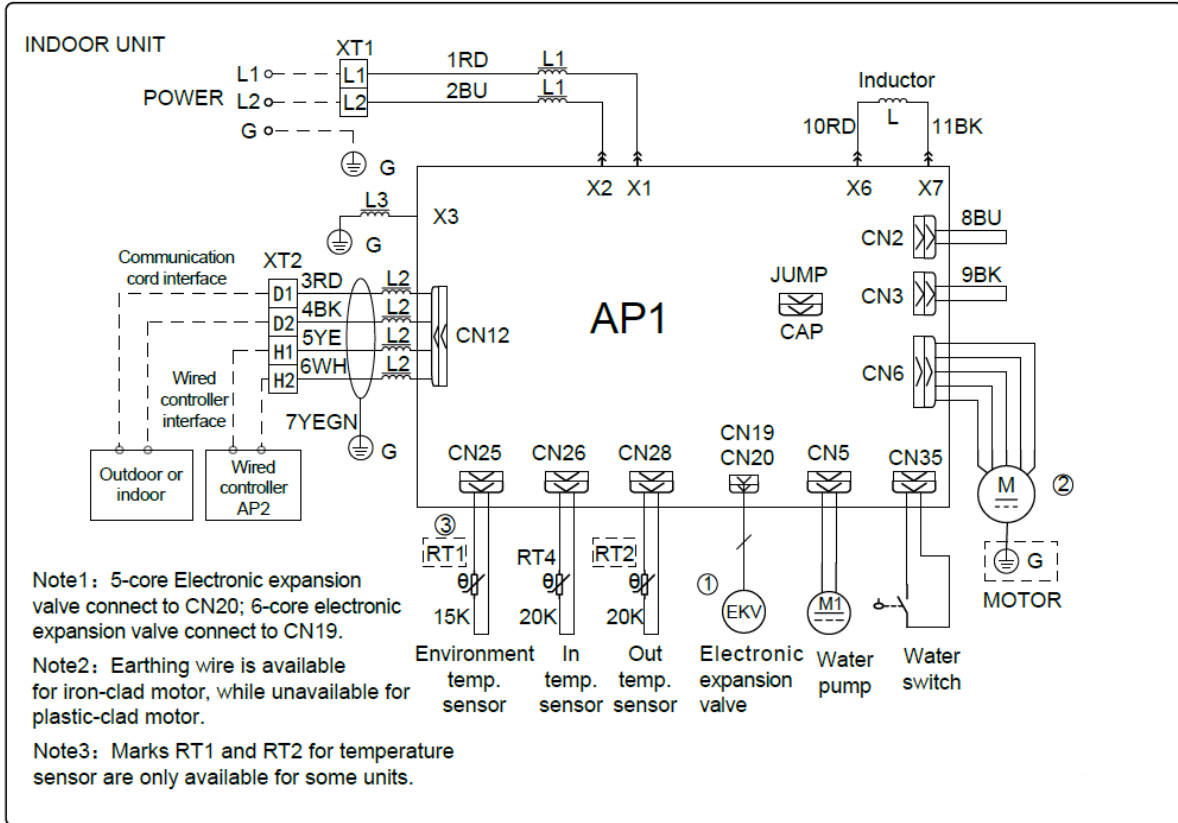

GMV-ND140PHS/B-T, GMV-ND160PHS/B-T:

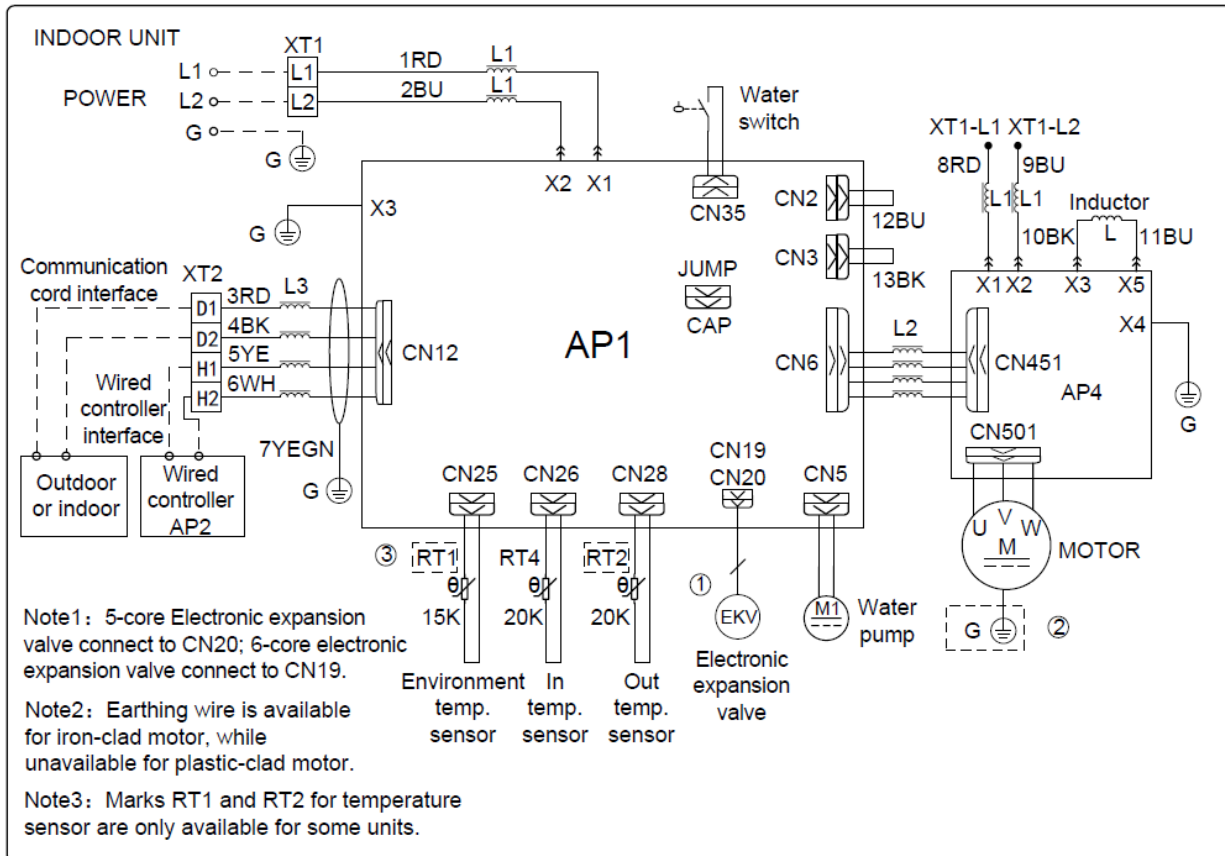

GMV-ND180PHS/B-T:

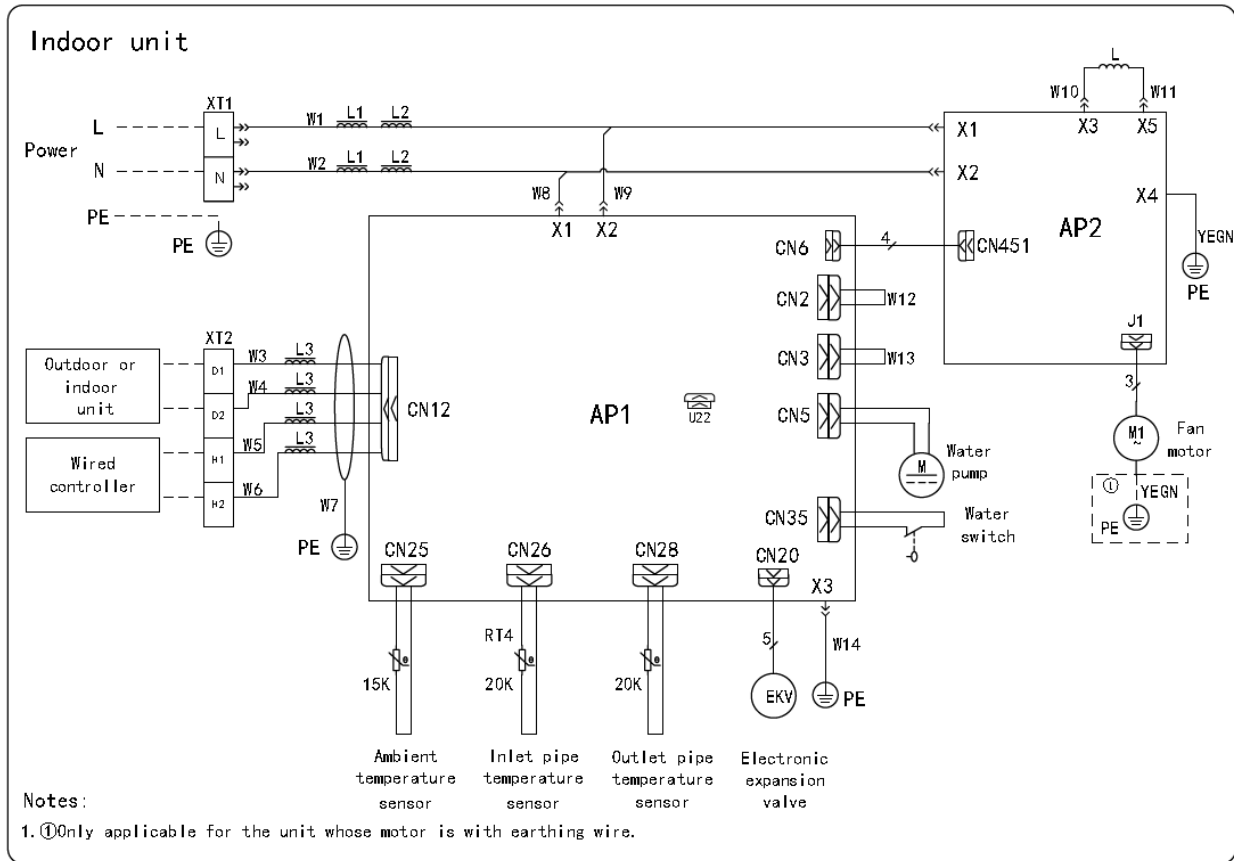

GMV-ND400PH/AR-X、GMV-ND450PH/AR-X、GMV-N560PH/AR-M

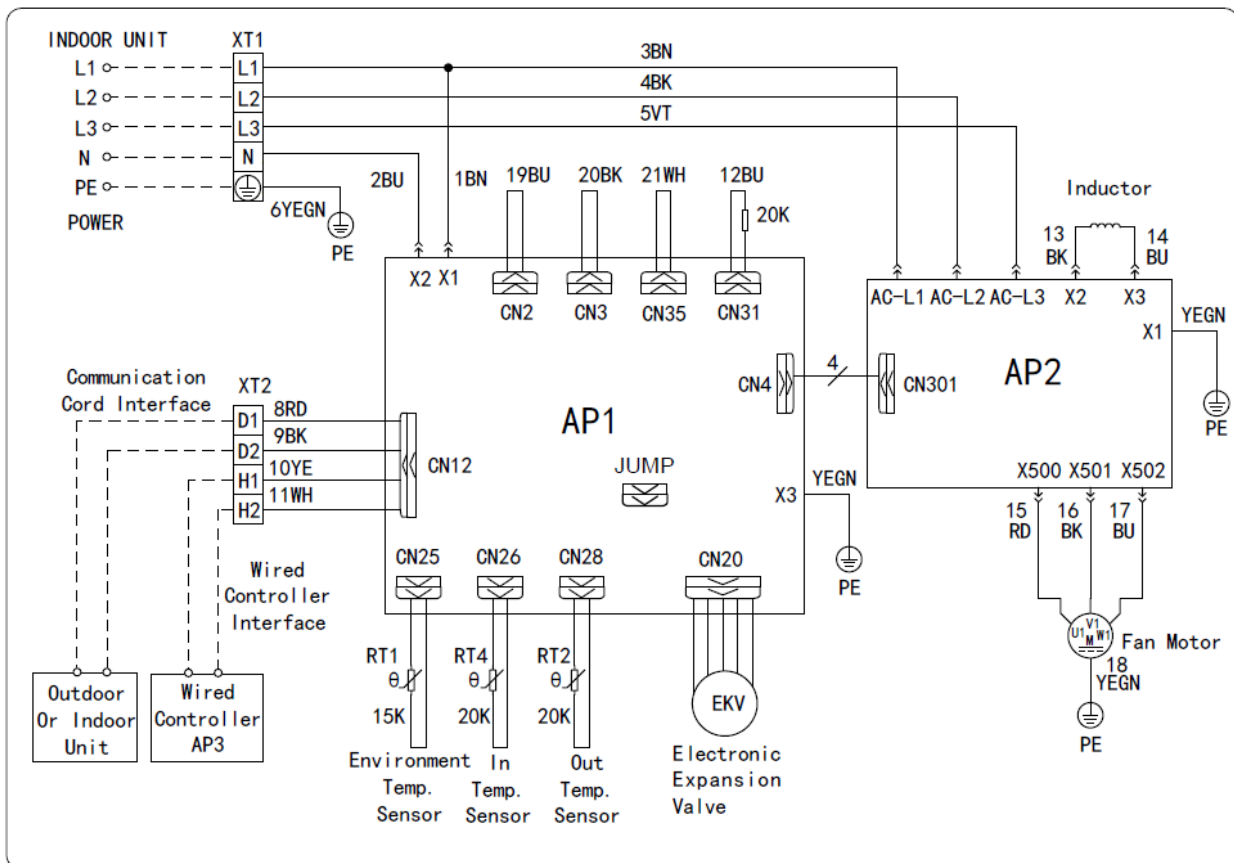

3.16 AHU-KIT Type

GMV-N36U/A-T, GMV-N71U/A-T, GMV-N140U/A-T, GMV-N280U/A-T, GMV-N560U/A-T:

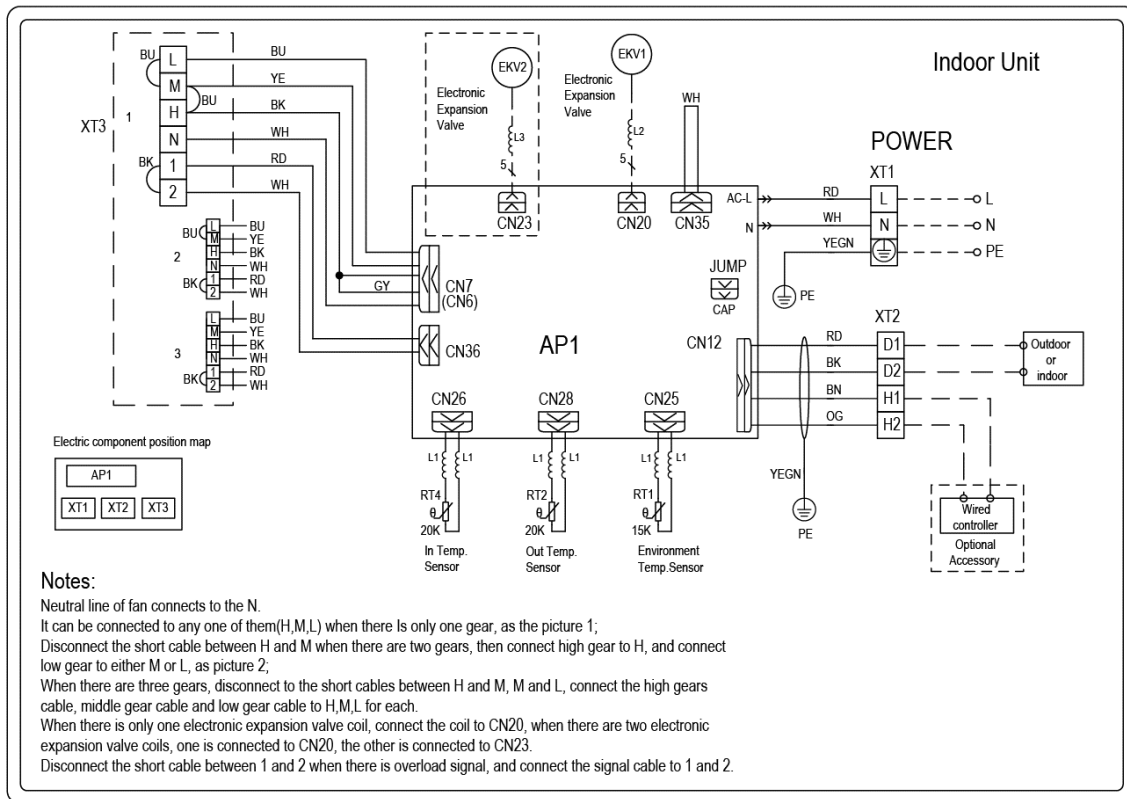

GMV-N36U/B-T, GMV-N71U/B-T, GMV-N140U/B-T, GMV-N280U/B-T, GMV-N560U/B-T,
 GMV-N36U/C-T, GMV-N71U/C-T, GMV-N140U/C-T, GMV-N280U/C-T, GMV-N560U/C-T:

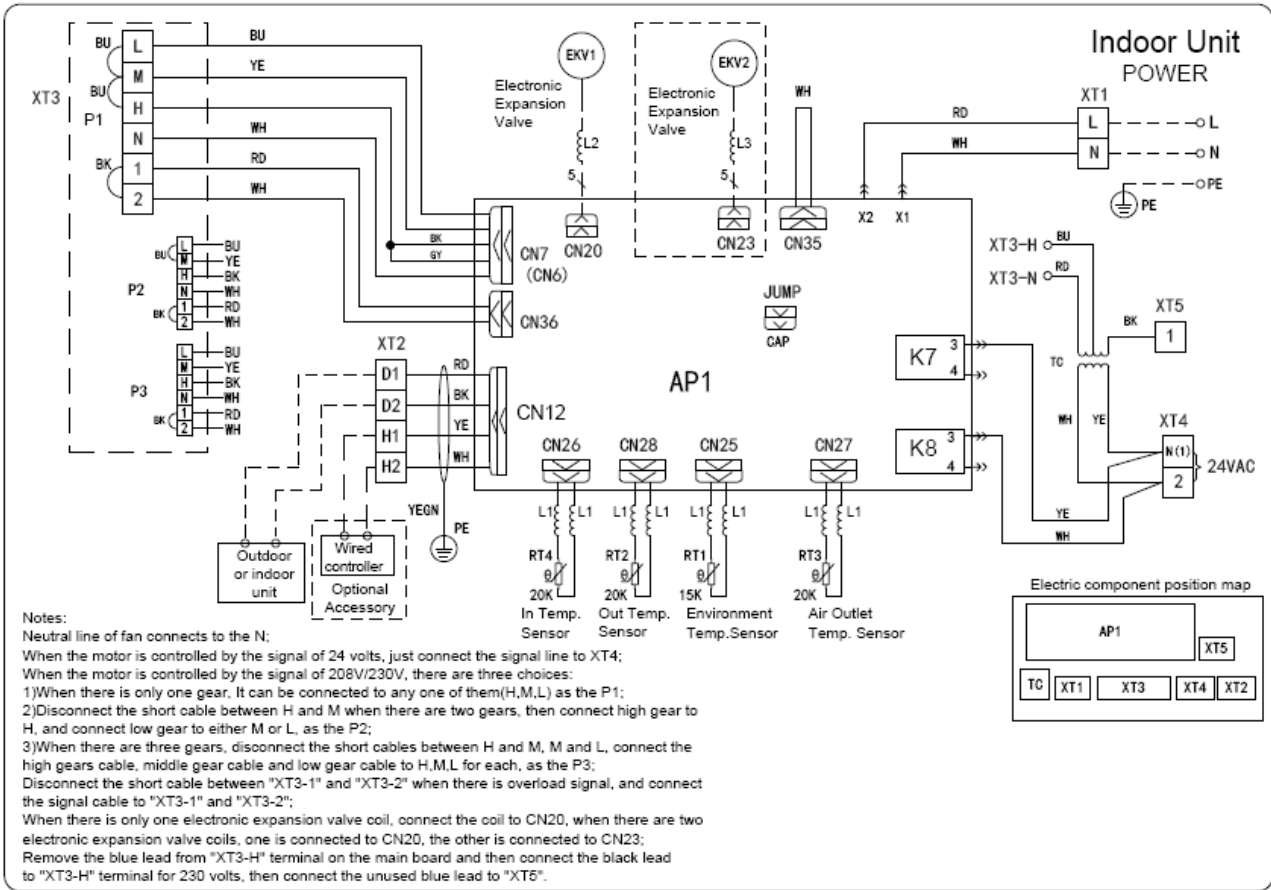

3.17 Concealed Floor Standing Type

GMV-ND22ZA/A-T, GMV-ND28ZA/A-T, GMV-ND36ZA/A-T, GMV-ND45ZA/A-T, GMV-ND56ZA/A-T, GMV-ND63ZA/A-T, GMV-ND71ZA/A-T:

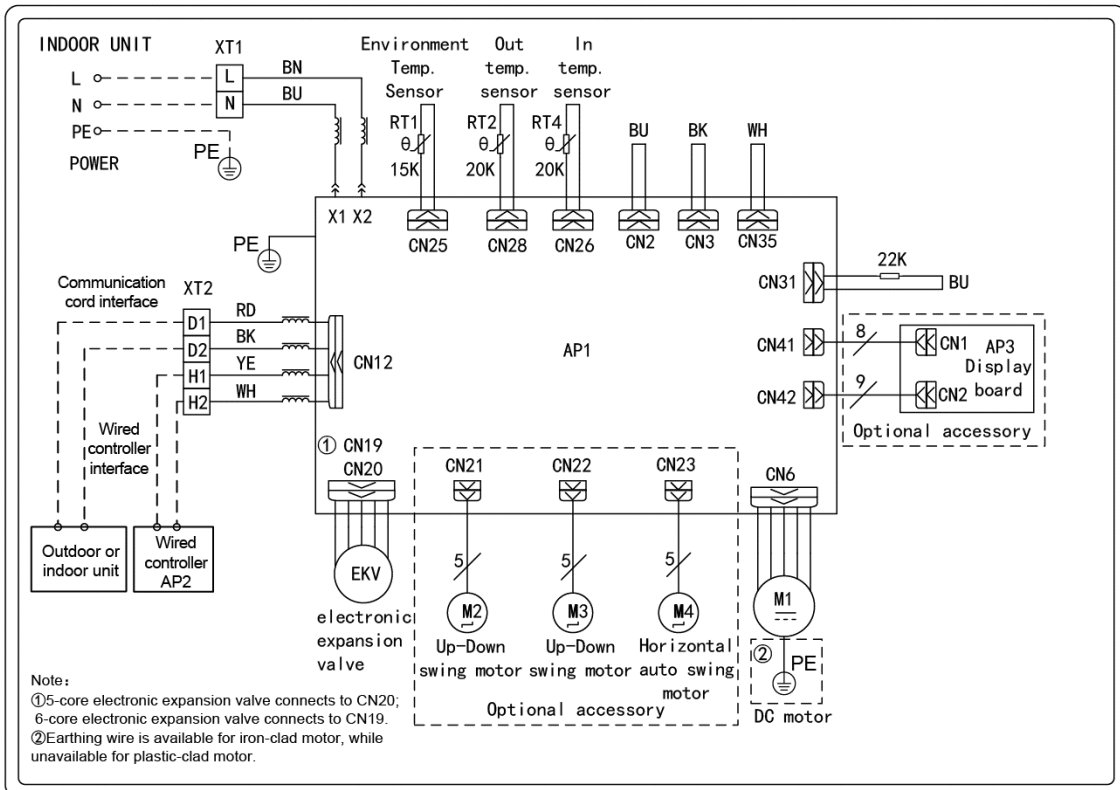

3.18 360° Air Discharge Cassette Type

GMV-ND22T/C-T, GMV-ND28T/C-T, GMV-ND36T/C-T, GMV-ND45T/C-, GMV-ND50T/C-T, GMV-ND56T/C-T, GMV-ND63T/C-T, GMV-ND71T/C-T, GMV-ND80T/C-T, GMV-ND90T/C-, GMV-ND100T/C-T, GMV-ND112T/C-T, GMV-ND125T/C-T, GMV-ND140T/C-T:

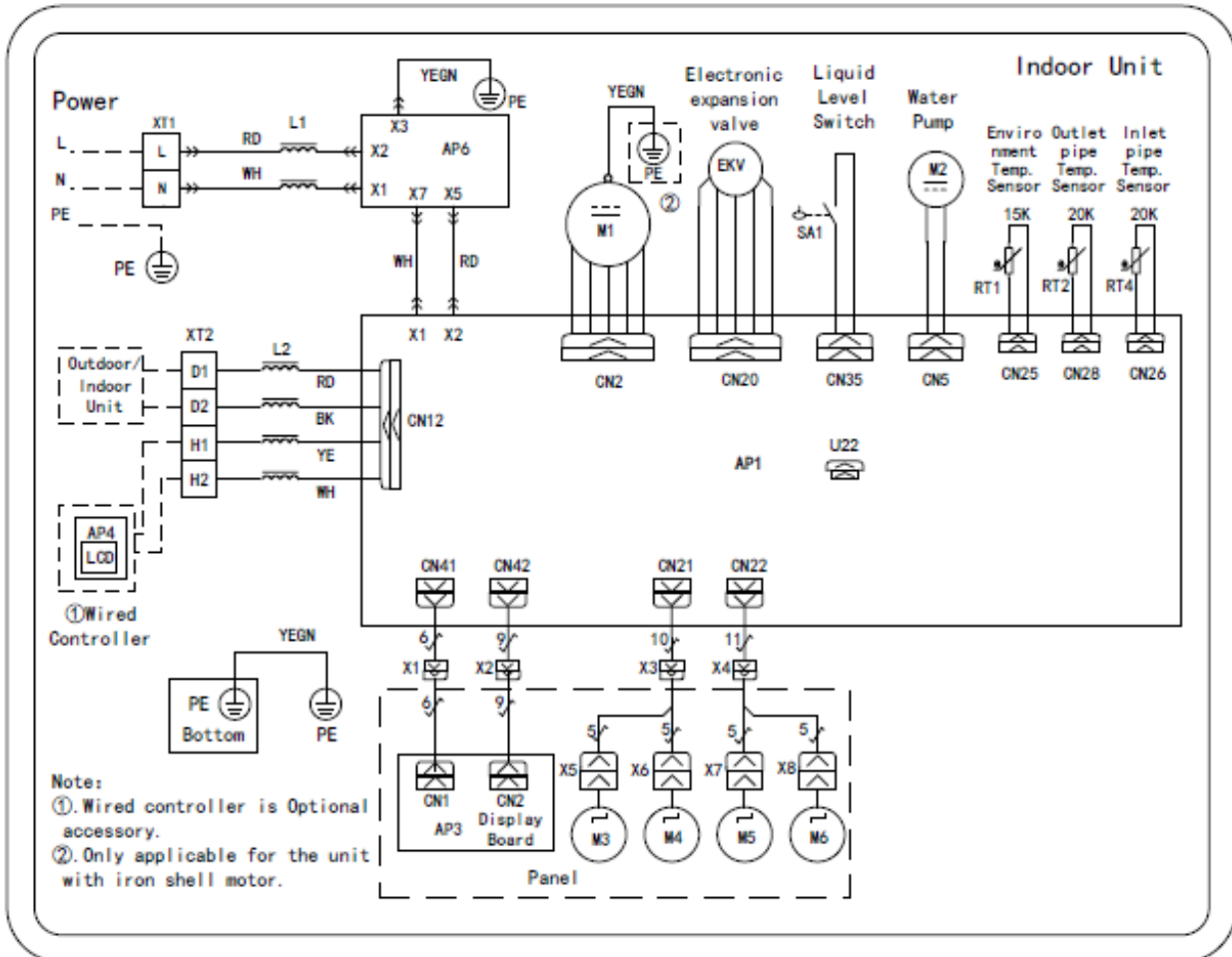

3.19 Heat Storage Module

XRZ180L/A-T

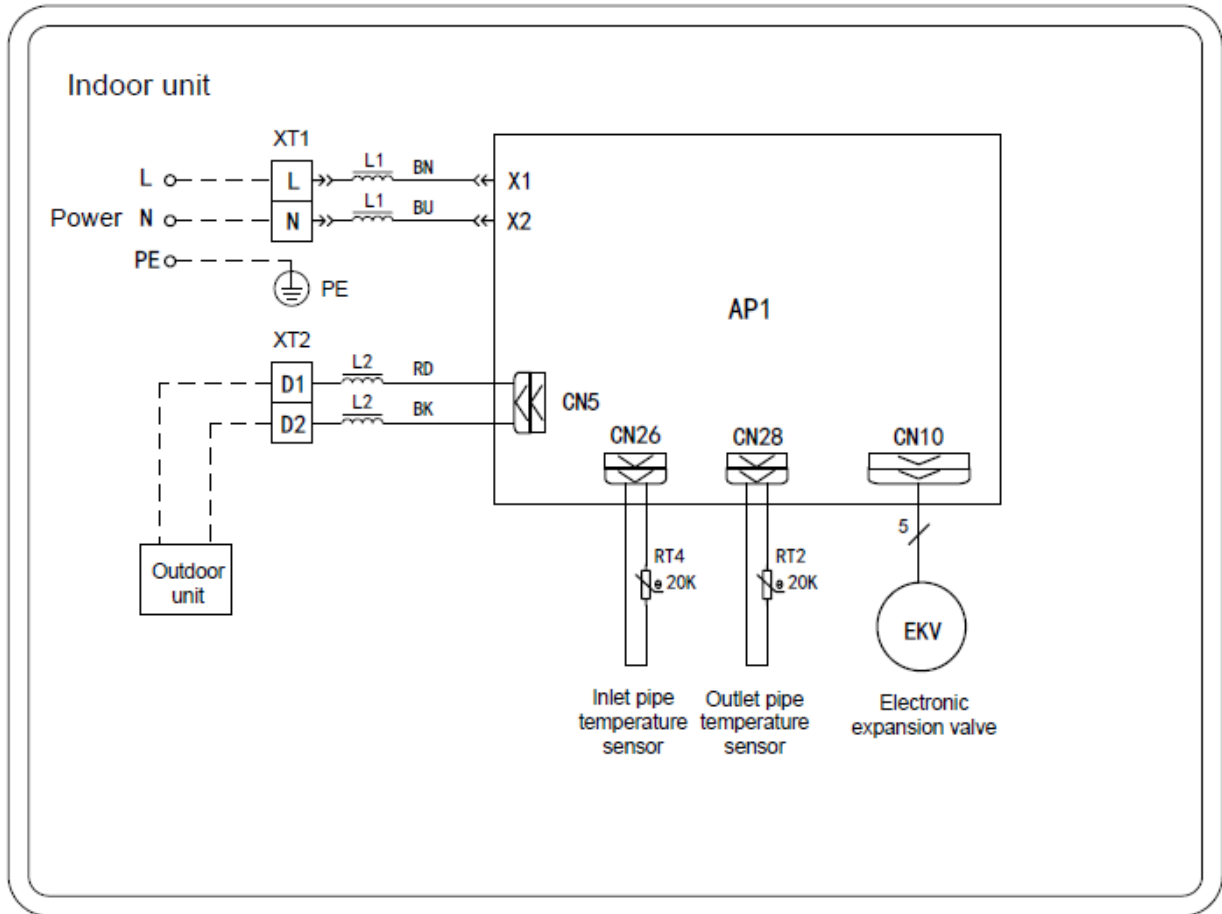

4 Disassembly and Assembly Procedure of Main Parts

4.1 Floor Standing Type

Removal and Assembly of electric box		
Remarks: Before removing the electric box, make sure to cut off the power firstly.		
Step	Illustration	Handling Instruction
1. Loosen the buckles on both sides of the bottom panel.		Cut off the power supply of indoor unit. Loosen the buckles on both sides of the bottom panel.

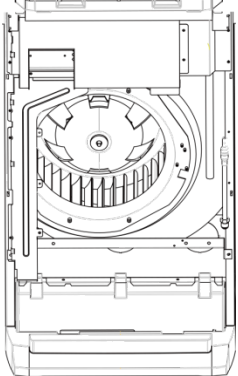
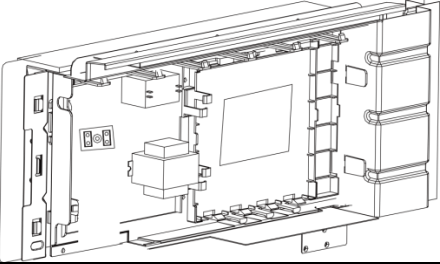
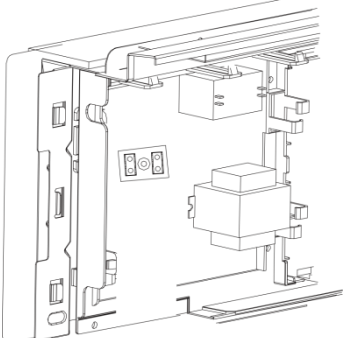
Removal and Assembly of electric box		
Remarks: Before removing the electric box, make sure to cut off the power firstly.		
Step	Illustration	Handling Instruction
2. Unscrew the screws on the bottom panel and then pull it out outwards.		Unscrew the screws on the bottom panel and then pull it out outwards.
3. Unscrew the screws on the electric box and then open the cover of it.		Unscrew the screws on the electric box and then open the cover of it.
4. Connect the power cord and the connection pipe.		Connect the power cord and the connection pipe.

4.2 High Static Pressure Duct Type

Note:

The following steps are specific for GMV-ND71PHS/A-T units. For other units, the assembly and disassembly procedure is similar except the specifications of centrifugal fans and motors.

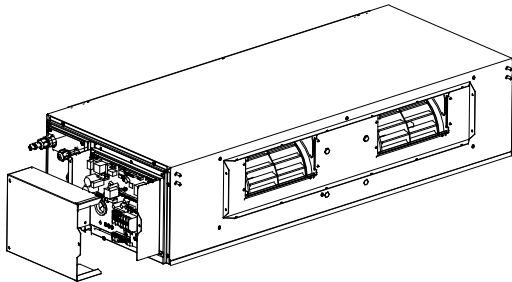
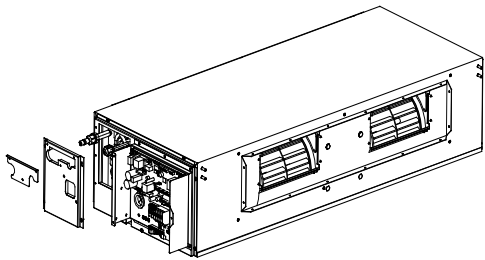
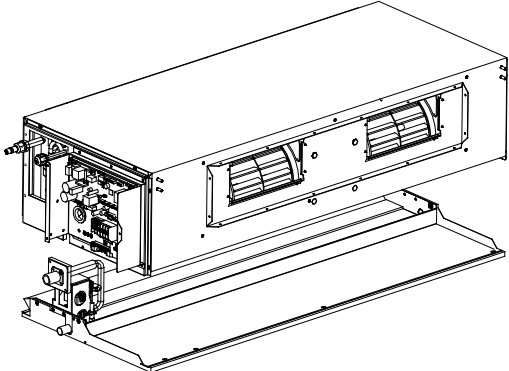
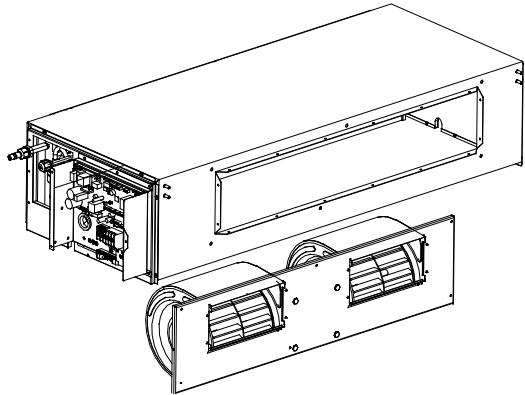
Motor and fan		
Precondition: The power supply has been disconnected.		
Step	Diagram	Operation Procedure
1. Remove the line connecting to the motor.		<ul style="list-style-type: none"> ●Use a screwdriver to unscrew the electric box cover. ●Remove from the master board the line connecting to the motor and remove the tie.
2. Disassemble the seal plate and cover plate.		<ul style="list-style-type: none"> ●Use a screwdriver to unscrew the seal plate and cover plate and then remove them.
3. Remove the cover plate component.		<ul style="list-style-type: none"> ●Use a screwdriver to unscrew the cover plate component.
4. Disassemble the centrifugal fan.		<ul style="list-style-type: none"> ●Use a screwdriver to unscrew the centrifugal fan.

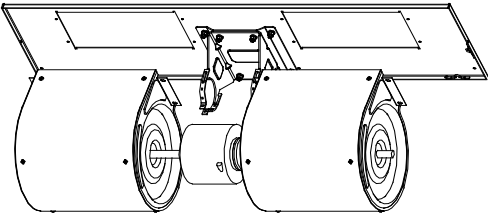
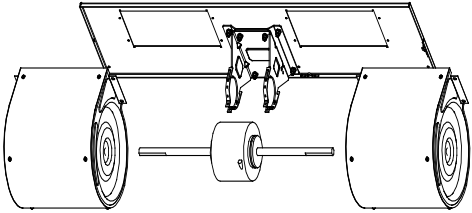
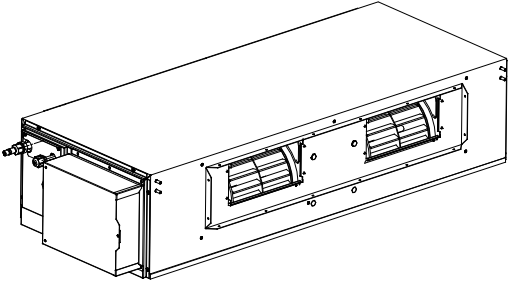
Motor and fan		
Precondition: The power supply has been disconnected.		
Step	Diagram	Operation Procedure
5. Remove the motor and centrifugal fan.		<ul style="list-style-type: none"> ●Use a screwdriver to unscrew the centrifugal fan. ●Loosen the fasteners of the motor and remove the motor from the support. ●For motors that are accompanied with supports, the supports need removing as well.
6. Remove the centrifugal fan.		<ul style="list-style-type: none"> ●Use a hexagon to unscrew the fan and remove the centrifugal fan from the motor axle.
7. Install a new motor.		<ul style="list-style-type: none"> ●Assemble units based on the reverse order of this procedure and power on the units for test.

4.3 Low Static Pressure Duct Type

Note:

The following steps are specific for GMV-ND22PLS/A-T units. For GMV-ND22PLS/A-T~GMV-ND140PLS/A-T units, the assembly and disassembly procedure is similar except the numbers of centrifugal fans and motors.

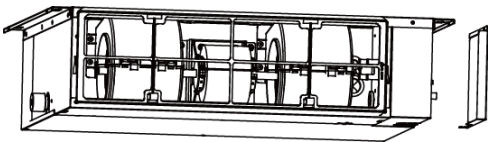
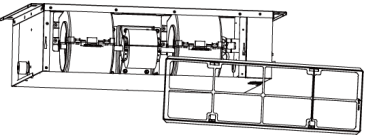
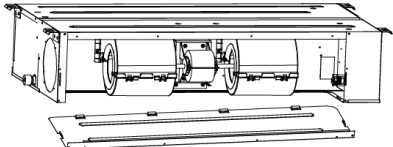
Motor and fan		
Precondition: The power supply has been disconnected.		
Step	Diagram	Operation Procedure
1. Remove the line connecting to the motor.		<ul style="list-style-type: none"> ●Use a screwdriver to unscrew the electric box cover. ●Remove from the master board the line connecting to the motor and remove the tie.
2. Remove the filter.		<ul style="list-style-type: none"> ●Remove the filter from the air return frame.
3. Remove the air return cover plate.		<ul style="list-style-type: none"> ●Use a screwdriver to unscrew the air return cover plate.

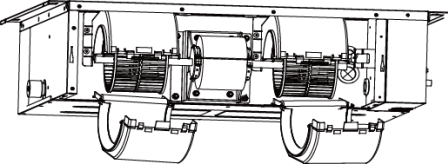
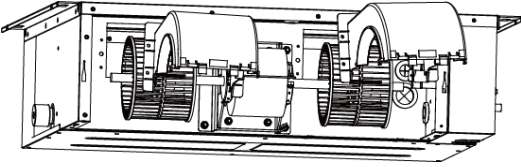
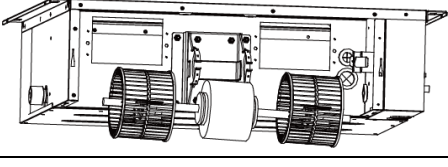
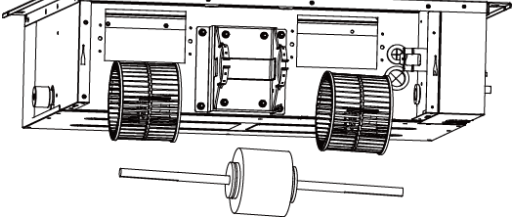
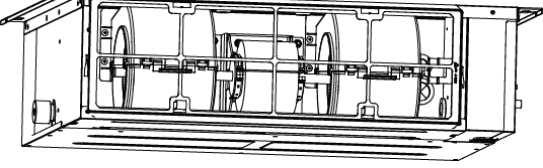
Motor and fan		
Precondition: The power supply has been disconnected.		
Step	Diagram	Operation Procedure
4. Remove the rear volute casing.		<ul style="list-style-type: none"> Loosen the fasteners that connect the rear volute casing with the front volute casing and remove the rear volute casing.
5. Remove the front volute casing.		<ul style="list-style-type: none"> Use a screwdriver to unscrew the front volute casing and then remove the volute casing.
6. Loosen the centrifugal fan and motor.		<ul style="list-style-type: none"> Use a hexagon to unscrew the centrifugal fan and loosen the fasteners of the motor.
7. Remove the motor.		<ul style="list-style-type: none"> Remove the motor from the support and remove the centrifugal fan from the motor axle. Then, remove the motor. For motors that are accompanied with supports, the supports need removing as well.
8. Install a new motor.		<ul style="list-style-type: none"> Assemble units based on the reverse order of this procedure and power on the units for test.

Note:

The following steps are specific for GMV-ND22PLS/C-T units. For GMV-ND18PLS/C-T~GMV-ND71PLS/C-T units, the assembly and disassembly procedure is similar except the numbers of louvers and motors.

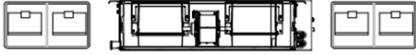
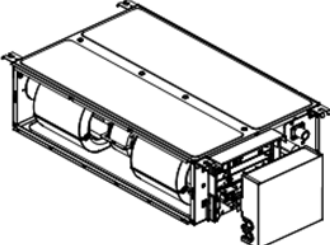
Motor and fan		
Precondition: The power supply has been disconnected.		
Step	Diagram	Operation Procedure
1. Remove the air return filter.		<ul style="list-style-type: none"> Draw the air return filter to both sides respectively at the return air inlet.
2. Remove the cover plate of the electric box.		<ul style="list-style-type: none"> Disconnect the power supply of the IDUs, use a screwdriver to unscrew the cover plate of the electric box, and then remove the line connecting to the motor.

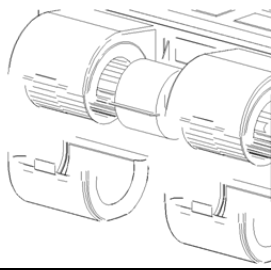
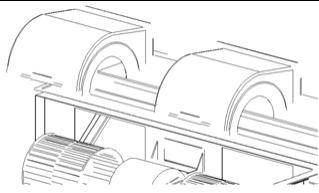
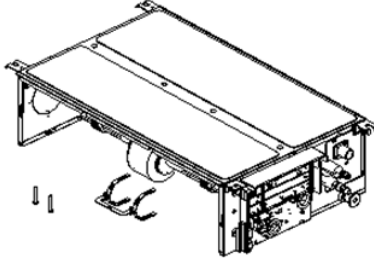
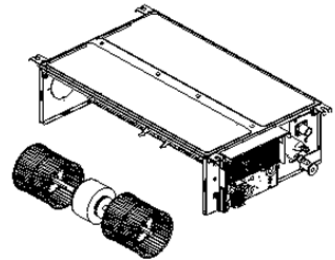
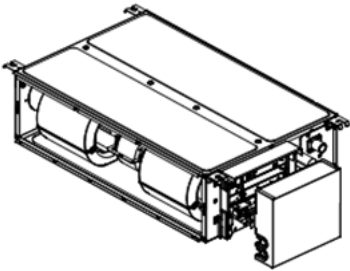
Motor and fan		
Precondition: The power supply has been disconnected.		
Step	Diagram	Operation Procedure
3. Remove the rear volute casing.		<ul style="list-style-type: none"> ●Loosen the fasteners that connect the rear volute casing with the front volute casing and remove the rear volute casing.
4. Remove the front volute casing.		<ul style="list-style-type: none"> ●Use a screwdriver to unscrew the front volute casing and then remove the volute casing.
5. Remove the louver and motor.		<ul style="list-style-type: none"> ●Use a screwdriver to unscrew the louver and loosen the fasteners of the motor.
6. Install a new motor.		<ul style="list-style-type: none"> ●Remove the motor from the support and remove the louver from the motor. Then, remove the motor. ●Install a new motor.
7. Install units in a reverse order of this procedure.		<ul style="list-style-type: none"> ●Assemble units based on the reverse order of this procedure and power on the units for test.

Note:

The following steps are specific for GMV-ND80PLS/C-T units. For GMV-ND80PLS/C-T~GMV-ND140PLS/C-T units, the assembly and disassembly procedure is similar except the numbers of centrifugal fans and motors.

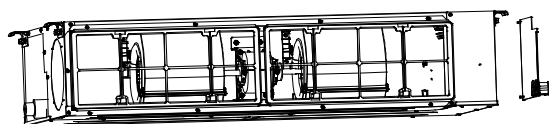
Motor and fan		
Precondition: The power supply has been disconnected.		
Step	Diagram	Operation Procedure
1. Remove the line connecting to the motor.		<ul style="list-style-type: none"> ●Use a screwdriver to unscrew the electric box cover. ●Remove from the master board the line connecting to the motor and remove the tie.

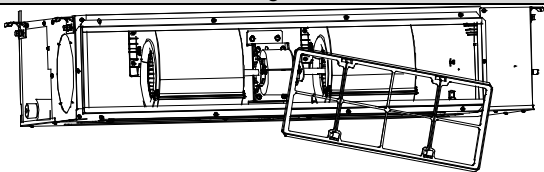
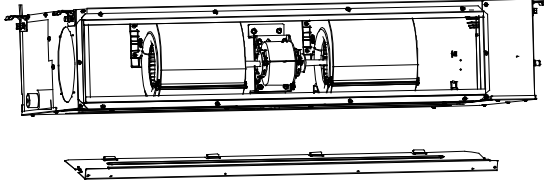
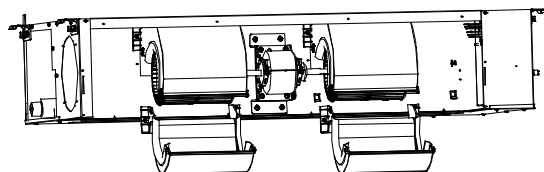
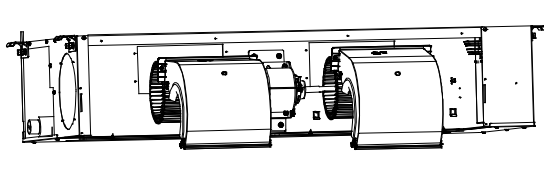
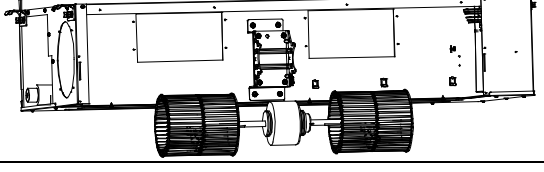
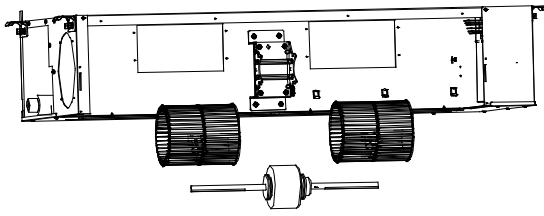
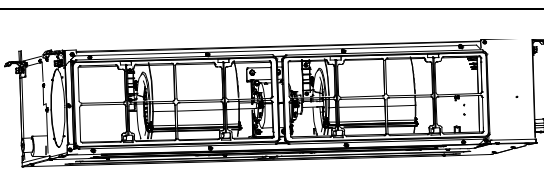
Motor and fan		
Precondition: The power supply has been disconnected.		
Step	Diagram	Operation Procedure
2. Remove the filter.		<ul style="list-style-type: none"> ●Remove the filter from the air return frame.
3. Remove the air return cover plate.		<ul style="list-style-type: none"> ●Use a screwdriver to unscrew the air return cover plate.
4. Remove the rear volute casing.		<ul style="list-style-type: none"> ●Loosen the fasteners that connect the rear volute casing with the front volute casing and remove the rear volute casing.
5. Remove the front volute casing.		<ul style="list-style-type: none"> ●Use a screwdriver to unscrew the front volute casing and then remove the volute casing.
6. Loosen the centrifugal fan and motor.		<ul style="list-style-type: none"> ●Use a hexagon to unscrew the centrifugal fan and loosen the fasteners of the motor.
7. Remove the motor.		<ul style="list-style-type: none"> ●Remove the motor from the support and remove the centrifugal fan from the motor axle. Then, remove the motor. ●For motors that are accompanied with supports, the supports need removing as well.
8. Install a new motor.		<ul style="list-style-type: none"> ●Assemble units based on the reverse order of this procedure and power on the units for test.

4.4 4-way Cassette Type

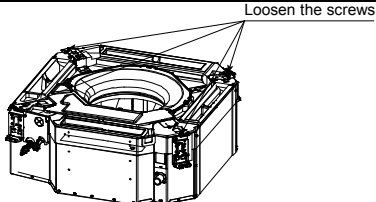
Motor and fan		
Step	Diagram	Operation Procedure
1. Unscrew the water tray.		<ul style="list-style-type: none"> ●Use a screwdriver to unscrew the water tray.

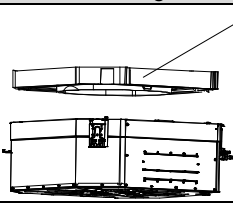
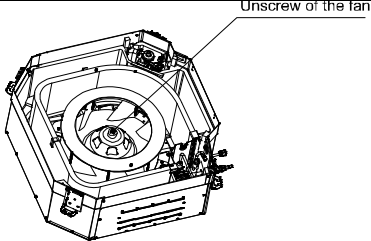
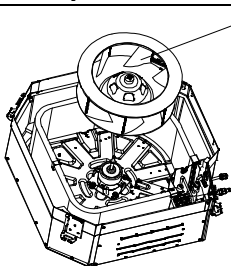
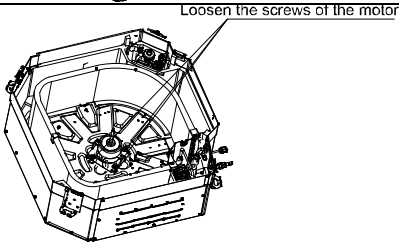
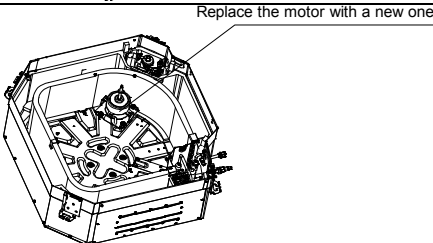
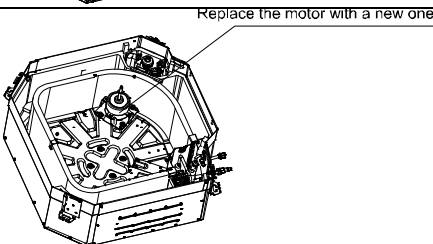
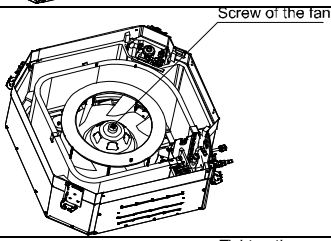
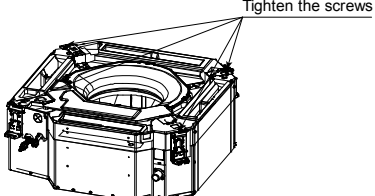
Motor and fan		
Step	Diagram	Operation Procedure
2. Remove the water tray.		<ul style="list-style-type: none"> ● Remove the water tray.
3. Unscrew the centrifugal fan.		<ul style="list-style-type: none"> ● Use a wrench to unscrew the centrifugal fan.
4. Remove the centrifugal fan.		<ul style="list-style-type: none"> ● Remove the centrifugal fan.
5. Unscrew the motor.		<ul style="list-style-type: none"> ● Use a screwdriver to unscrew the motor.
6. Replace the motor with a new one.		<ul style="list-style-type: none"> ● Replace the motor with a new one.
7. Screw the motor.		<ul style="list-style-type: none"> ● Use a screwdriver to screw the motor.
8. Install and screw the centrifugal fan.		<ul style="list-style-type: none"> ● Install the centrifugal fan and use a wrench to screw the centrifugal fan.
9. Install and screw the water tray.		<ul style="list-style-type: none"> ● Use a screwdriver to screw the water tray

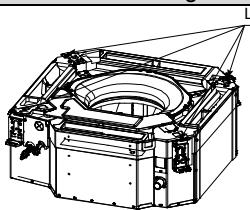
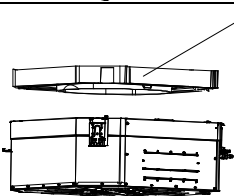
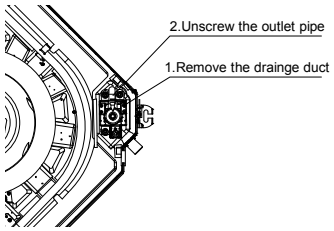
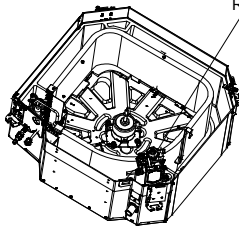
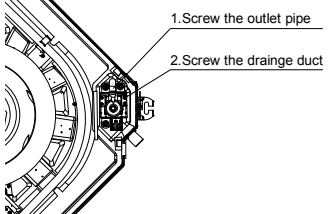
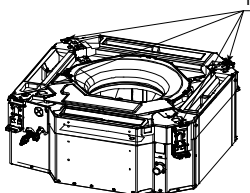
Pump		
Step	Diagram	Operation Procedure
1. Unscrew the water tray.		<ul style="list-style-type: none"> ●Use a screwdriver to unscrew the water tray.
2. Remove the water tray.		<ul style="list-style-type: none"> ●Replace the water tray.
3. Remove the drainage duct and unscrew the pump.		<ul style="list-style-type: none"> 3. Remove the drainage duct and use a screwdriver to unscrew the pump.
4. Replace the pump.		<ul style="list-style-type: none"> ●Replace the pump.
5. Connect the drainage duct and screw the new pump.		<ul style="list-style-type: none"> ●Connect the drainage duct and use a screwdriver to screw the new pump.
6. Install and screw the water tray.		<ul style="list-style-type: none"> ●Use a screwdriver to screw the water tray.

4.5 Compact 4-way Cassette Type

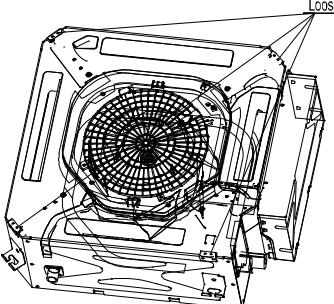
Motor and fan		
Step	Diagram	Operation Procedure
1. Unscrew the water tray.		<ul style="list-style-type: none"> ●Use a screwdriver to unscrew the water tray.

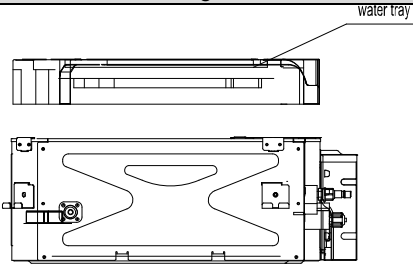
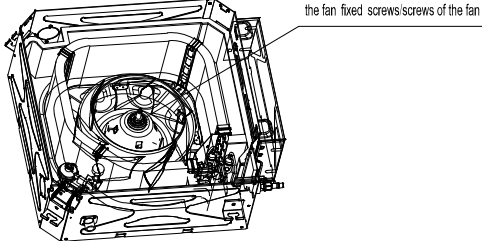
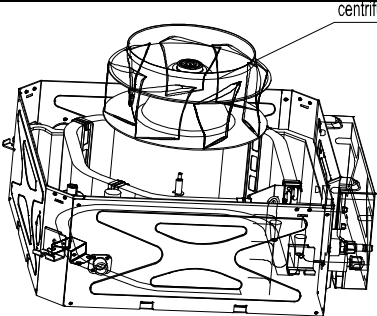
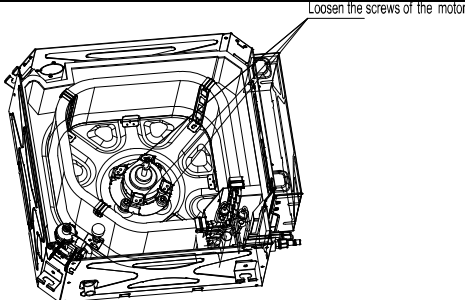
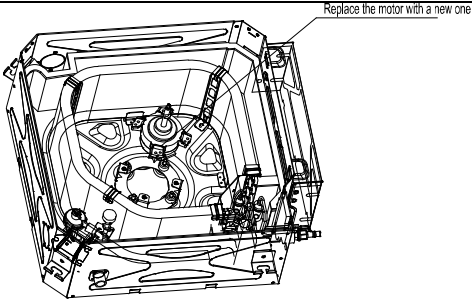
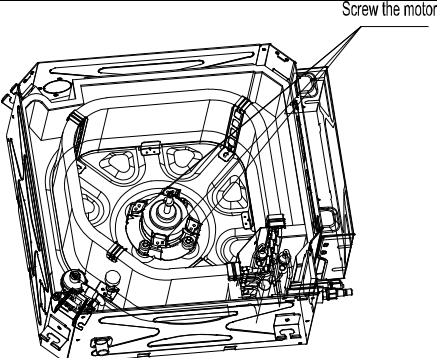
Motor and fan		
Step	Diagram	Operation Procedure
2. Remove the water tray.	 <p>water tray</p>	<ul style="list-style-type: none"> ● Remove the water tray.
3. Unscrew the centrifugal fan.	 <p>the fan fixed screws/screws of the fan</p>	<ul style="list-style-type: none"> ● Use a wrench to unscrew the centrifugal fan.
4. Remove the centrifugal fan.	 <p>centrifugal fan</p>	<ul style="list-style-type: none"> ● Remove the centrifugal fan.
5. Unscrew the motor.	 <p>Loosen the screws of the motor</p>	<ul style="list-style-type: none"> ● Use a screwdriver to unscrew the motor.
6. Replace the motor with a new one.	 <p>Replace the motor with a new one</p>	<ul style="list-style-type: none"> ● Replace the motor with a new one.
7. Screw the motor.	 <p>Screw the motor</p>	<ul style="list-style-type: none"> ● Use a screwdriver to screw the motor.

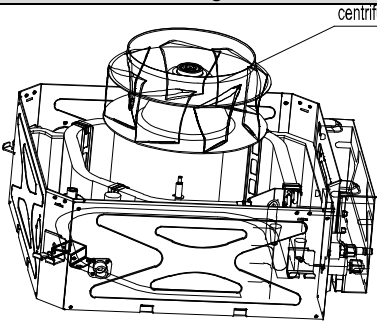
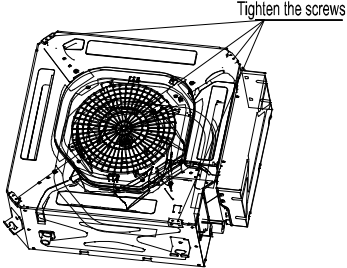
Motor and fan		
Step	Diagram	Operation Procedure
8. Install and screw the centrifugal fan.	 <p>centrifugal fan</p>	<ul style="list-style-type: none"> ● Install the centrifugal fan and use a wrench to screw the centrifugal fan.
9. Install and screw the water tray.	 <p>Tighten the screws</p>	<ul style="list-style-type: none"> ● Use a screwdriver to screw the water tray

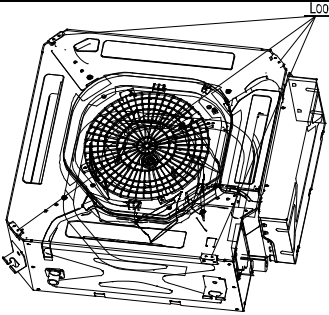
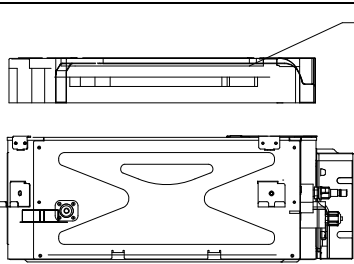
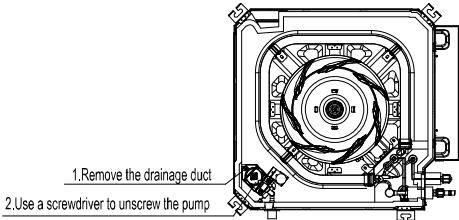
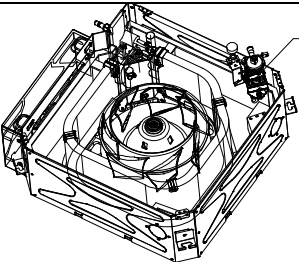
Pump		
Step	Diagram	Operation Procedure
1. Unscrew the water tray.	 <p>Loosen the screws of the water tray</p>	<ul style="list-style-type: none"> ● Use a screwdriver to unscrew the water tray.
2. Remove the water tray.	 <p>water tray</p>	<ul style="list-style-type: none"> ● Replace the water tray.
3. Remove the drainage duct and unscrew the pump.	 <p>1.Remove the drainage duct 2.Use a screwdriver to unscrew the pump</p>	<p>3. Remove the drainage duct and use a screwdriver to unscrew the pump.</p>
4. Replace the pump.	 <p>Replace the pump</p>	<ul style="list-style-type: none"> ● Replace the pump.

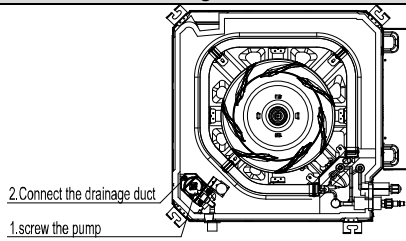
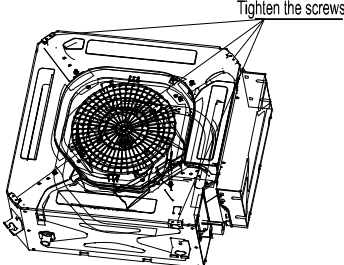
Motor and fan		
Step	Diagram	Operation Procedure
5. Connect the drainage duct and screw the new pump.	 <p>2.Connect the drainage duct 1.screw the pump</p>	<ul style="list-style-type: none"> ●Connect the drainage duct and use a screwdriver to screw the new pump.
6. Install and screw the water tray.	 <p>Tighten the screws</p>	<ul style="list-style-type: none"> ●Use a screwdriver to screw the water tray.

4.6 360° Air Discharge Compact Cassette Type

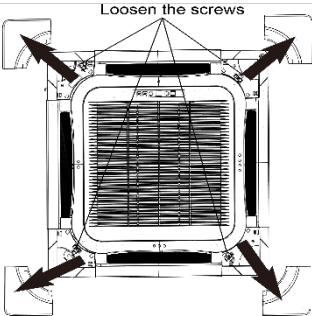
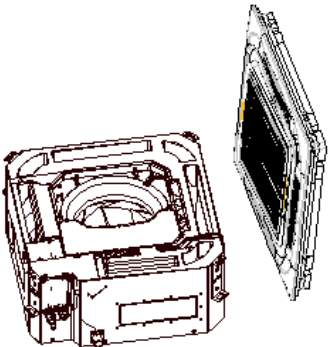
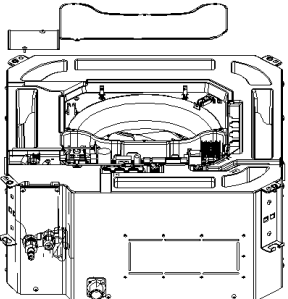
Motor and fan		
Step	Diagram	Operation Procedure
1. Remove the front panel.	 <p>Loosen the screws</p>	<ul style="list-style-type: none"> ●Turn off the power supply of indoor unit. ●Push the 4 corner plates in the directions shown by the arrows. ●Loosen the screws and remove the front panel.
		
2. Remove the cover of electric box and the clamp of power cord.		<ul style="list-style-type: none"> ●Remove the motor wire and water pump of the electric box.

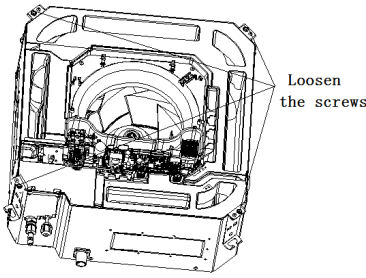
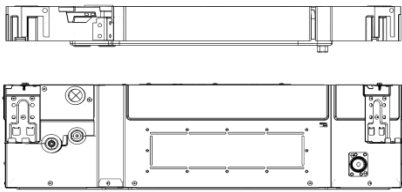
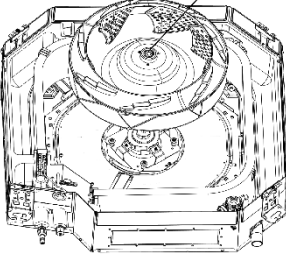
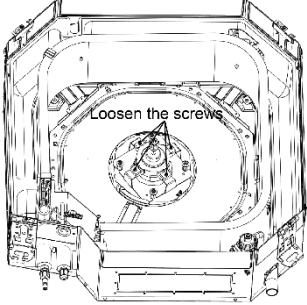
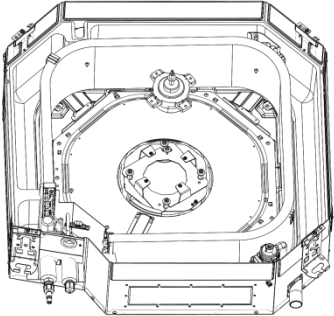
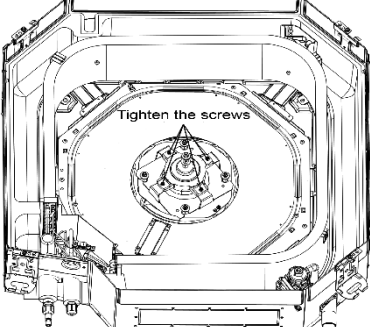
Motor and fan		
Step	Diagram	Operation Procedure
4. Remove the water tray.		<ul style="list-style-type: none"> ●Loosen the screws in the 4 corners and then remove the water tray.
		
5. Remove the fan.		<ul style="list-style-type: none"> ●Use a screwdriver to remove the clamping band of motor. Then remove the fan.
6. Remove motor.		<ul style="list-style-type: none"> ●Use a screwdriver to unscrew the 4 screws of motor. Then remove the motor.
		
7. Replace and install the motor.		<ul style="list-style-type: none"> ●Remove the motor from motor support and then replace with a new motor. ●Tighten the 4 screws of motor with a screwdriver.

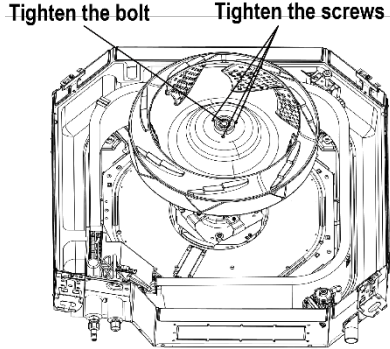
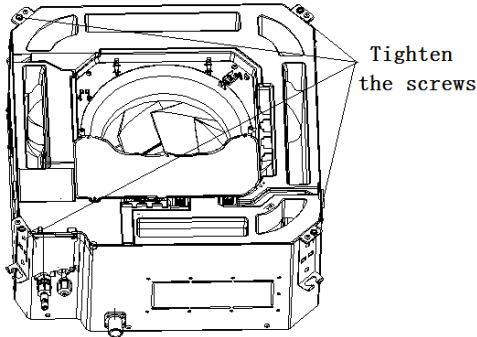
Motor and fan		
Step	Diagram	Operation Procedure
8. Install the fan.	 <p>Tighten the bolt Tighten the screws</p>	<ul style="list-style-type: none"> ●Direct the hole of fan to the motor shaft and then mount on the fan. ●Tighten the clamping band of motor with a wrench.
9. Install the water tray.	 <p>Tighten the screws</p>	<ul style="list-style-type: none"> ●Direct the 4 corners of water tray to the 4 corners of the unit and then press them. Use a screwdriver to tighten the screws in the 4 corners. ●Connect the power cord and water pump wire. ●Place back the cover of electric box and the clamp of power cord. Then tighten the screws with a screwdriver.

4.7 2-way Cassette Type

Note:

The following steps are specific for GMV-ND50TS/A-T units. For other units, the assembly and disassembly procedure is similar except the numbers of centrifugal fans and motors.

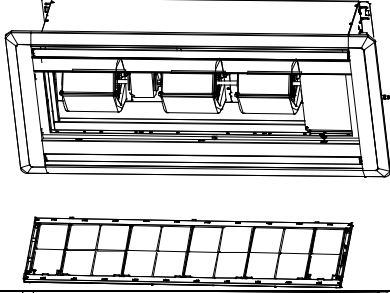
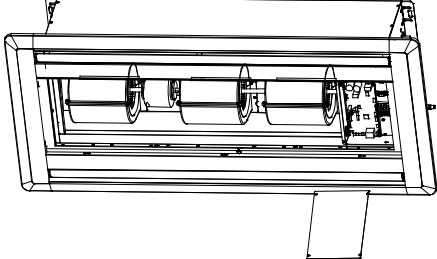
Removal of Fan Motor		
Precondition: The power supply has been disconnected.		
Step	Diagram	Operation Procedure
1. Remove the grille		<ul style="list-style-type: none"> ●Slip the fasteners on the panel, open the grille, remove it
2. Remove the line connecting to the motor.		<ul style="list-style-type: none"> ●Use a screwdriver to unscrew the electric box cover. ●Remove from the master board the line connecting to the motor and remove the tie.

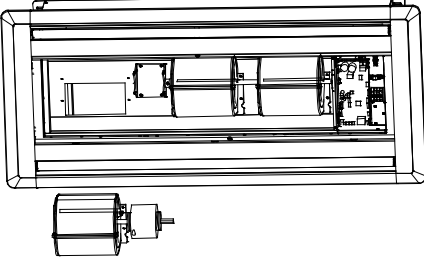
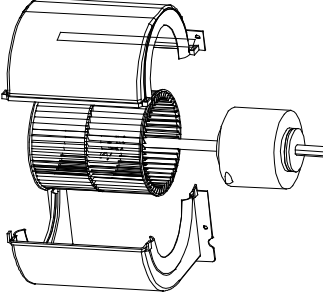
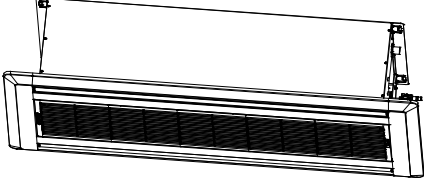
Removal of Fan Motor		
Precondition: The power supply has been disconnected.		
Step	Diagram	Operation Procedure
3. Remove the motor. Remove the motor from the support		<ul style="list-style-type: none"> ●Use a screwdriver to unscrew the motor, volute casing subassembly and joint slack. ●Loosen the fasteners of the motor, remove the motor from the support ●Remove the volute casing subassembly as well
4. Remove the centrifugal fan		<ul style="list-style-type: none"> ●Remove the volute casing ●Use a hexagon to unscrew the centrifugal fan, remove it from motor axle
5. Replace the motor with a new one.		<ul style="list-style-type: none"> ●Assemble units based on the reverse order of this procedure and power on the units for test.

4.8 1-way Cassette Type

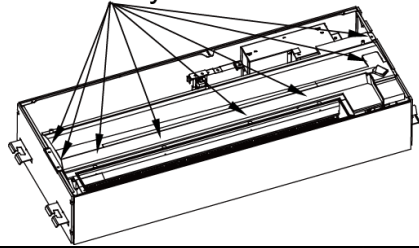
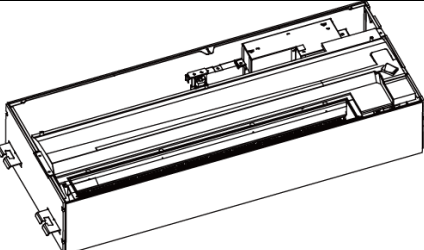
Motor and fan		
Step	Diagram	Operation Procedure
1. Unscrew the water tray.	<p>Unscrew the water tray</p> 	<ul style="list-style-type: none"> ●Use a screwdriver to unscrew the water tray.
2. Remove the water tray.		<ul style="list-style-type: none"> ●Remove the water tray.

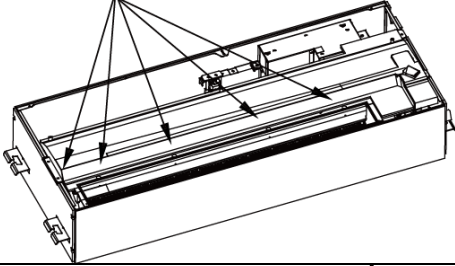
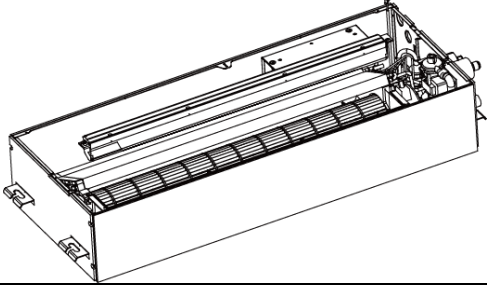
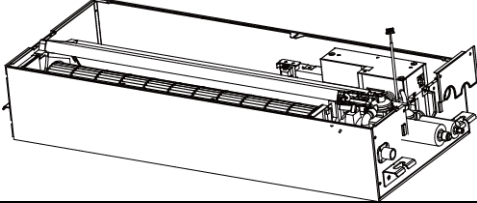
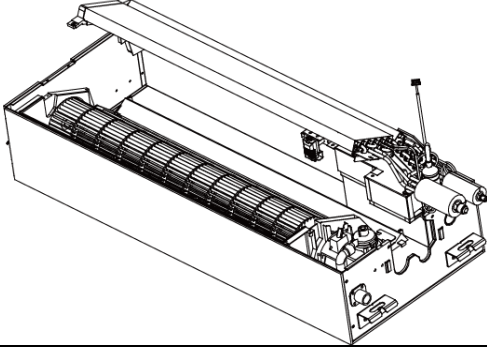
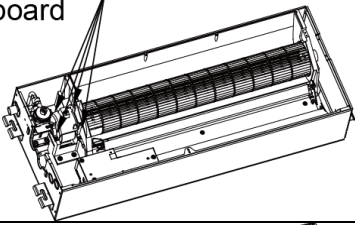
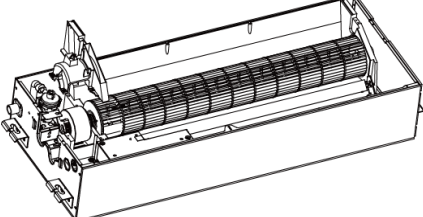
Motor and fan		
Step	Diagram	Operation Procedure
3. Unscrew the volute tongue.	<p>Unscrew the volute</p> 	<ul style="list-style-type: none"> ●Use a screwdriver to unscrew the volute tongue.
4. Remove the volute tongue.		<ul style="list-style-type: none"> ●Remove the volute tongue.
5. Unscrew the outlet board.		<ul style="list-style-type: none"> ●Use a screwdriver to unscrew the outlet board and then remove the board.
6. Remove the evaporator.		<ul style="list-style-type: none"> ●Remove the evaporator.
7. Unscrew the motor pressing board.	<p>Unscrew the motor pressing board</p> 	<ul style="list-style-type: none"> ●Use a screwdriver to unscrew the motor pressing board.
8. Remove the pressing board and replace the motor.		<ul style="list-style-type: none"> ●Remove the pressing board and replace the motor.

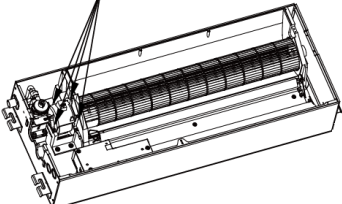
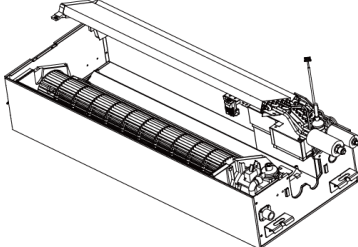
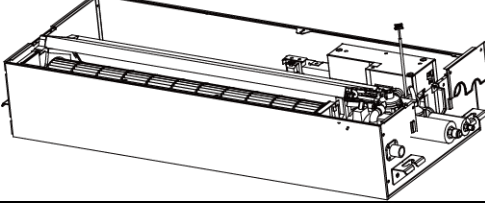
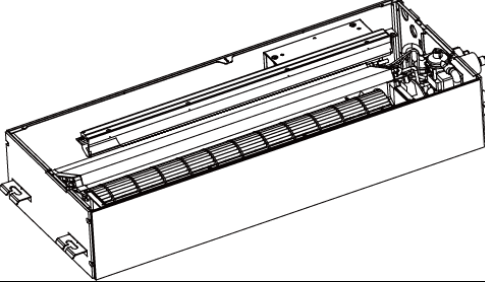
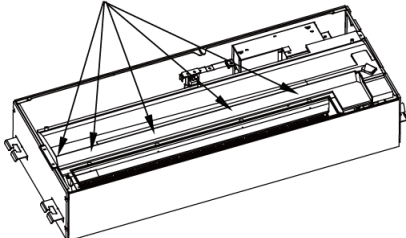
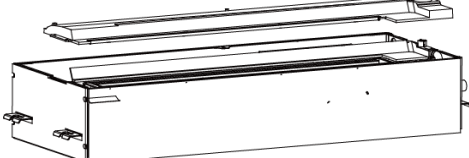
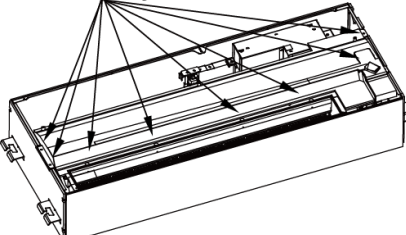
Motor and fan		
Step	Diagram	Operation Procedure
9. Screw the motor pressing board.	<p>Screw the motor pressing board</p> 	<ul style="list-style-type: none"> ●Use a screwdriver to screw the motor pressing board.
10. Install the evaporator.		<ul style="list-style-type: none"> ●Install the evaporator.
11. Screw the outlet board.		<ul style="list-style-type: none"> ●Use a screwdriver to screw the outlet board.
12. Put the volute tongue back to position.		<ul style="list-style-type: none"> ●Put the volute tongue back to position.
13. Screw the volute tongue.	<p>Screw the volute</p> 	<ul style="list-style-type: none"> ●Use a screwdriver to screw the volute tongue.
14. Install the water tray.		<ul style="list-style-type: none"> ●Install the water tray.
15. Screw the water tray.	<p>Screw the water tray</p> 	<ul style="list-style-type: none"> ●Use a screwdriver to screw the water tray.

4.9 Floor Ceiling Type

Note:

The following steps are specific for GMV-ND140ZD/A-T units. For other units, the assembly and disassembly procedure is similar except the numbers of centrifugal fans and motors.

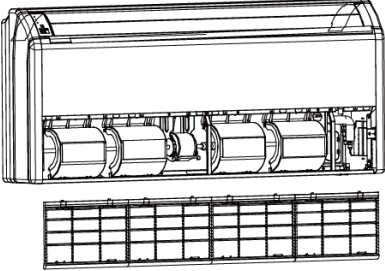
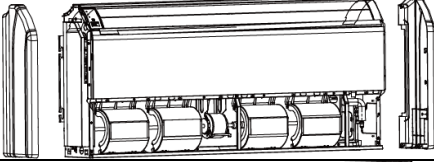
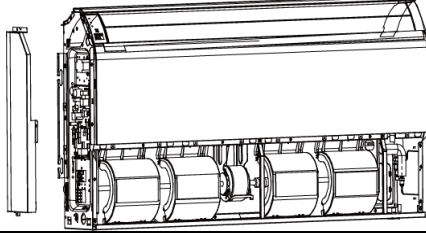
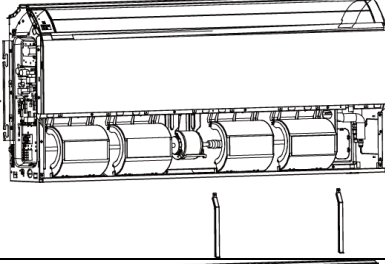
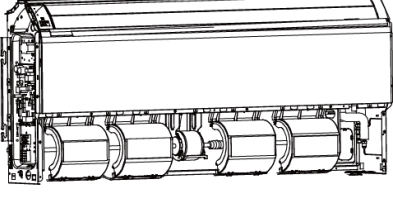
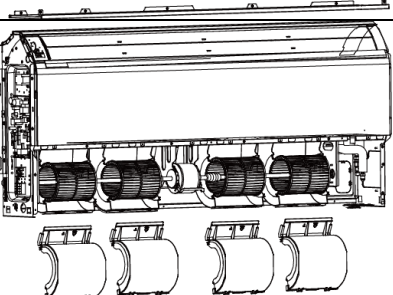
Motor and fan		
Precondition: The power supply has been disconnected.		
Step	Diagram	Operation Procedure
1. Remove the air return grille.		<ul style="list-style-type: none"> Loosen the fasteners of the air return grille and then remove the grille.
2. Remove the left and right cover plates.		<ul style="list-style-type: none"> Use a screwdriver to unscrew the left and right cover plates and then remove the cover plates.
3. Remove the electric box cover and the line connecting to the motor.		<ul style="list-style-type: none"> Use a screwdriver to unscrew the electric box cover. Remove from the master board the line connecting to the motor and remove the tie.
4. Remove the limit board.		<ul style="list-style-type: none"> Use a screwdriver to unscrew the limit board and then remove the board.
5. Remove the rear connecting board.		<ul style="list-style-type: none"> Use a screwdriver to unscrew the rear connecting board and then remove the board.
6. Remove the rear volute casing.		<ul style="list-style-type: none"> Loosen the fasteners that connect the rear volute casing with the front volute casing and remove the rear volute casing.

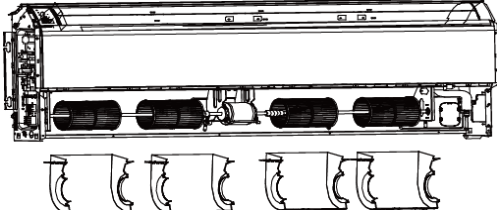
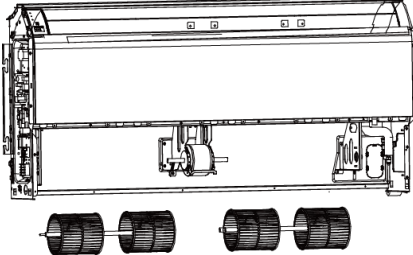
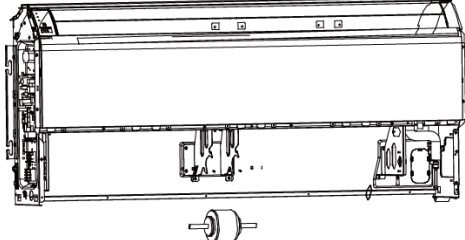
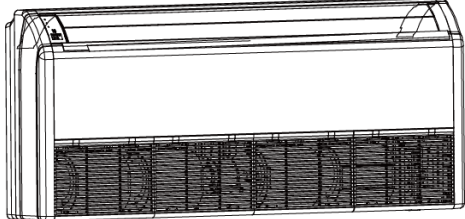
Motor and fan		
Precondition: The power supply has been disconnected.		
Step	Diagram	Operation Procedure
7. Remove the front volute casing.		<ul style="list-style-type: none"> ●Use a screwdriver to unscrew the front volute casing and then remove the volute casing.
8. Remove the centrifugal fan.		<ul style="list-style-type: none"> ●Loosen the fasteners that connect the coupler with the motor axle and remove the centrifugal fan.
9. Remove the motor.		<ul style="list-style-type: none"> ●Remove the motor from the support and remove the centrifugal fan from the motor axle. Then, remove the motor. ●For motors that are accompanied with supports, the supports need removing as well.
10. Install a new motor.		<ul style="list-style-type: none"> ●Assemble units based on the reverse order of this procedure and power on the units for test.

4.10 Fresh air Processing Unit

GMV-NX140P/A (X1.2)-K:

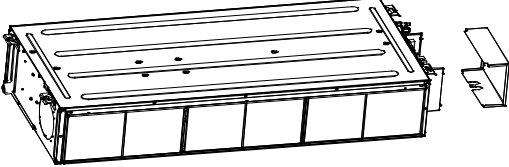
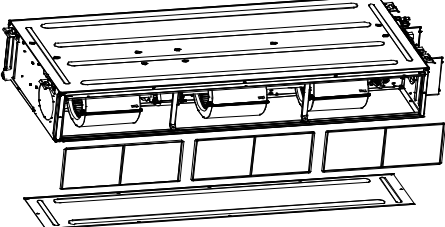
Motor and fan		
Precondition: The power supply has been disconnected.		
Step	Diagram	Operation Procedure
1. Remove the line connecting to the motor.		<ul style="list-style-type: none"> ●Use a screwdriver to unscrew the electric box cover. ●Remove from the master board the line connecting to the motor and remove the tie.
2. Remove the filter. And the air return cover plate.		<ul style="list-style-type: none"> ●Remove the filter from the air return frame. ●Use a screwdriver to unscrew the air return cover plate.

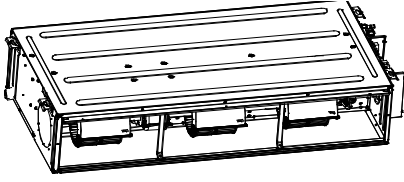
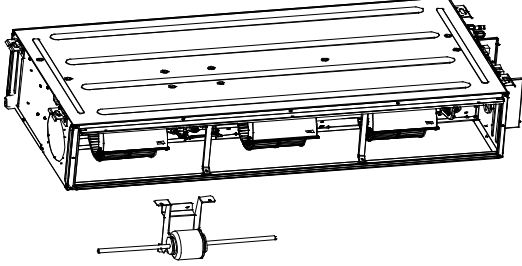
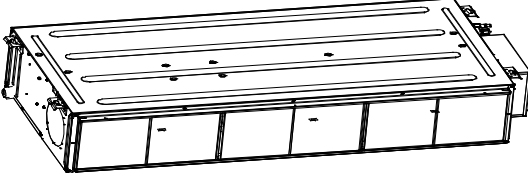
Motor and fan		
Precondition: The power supply has been disconnected.		
Step	Diagram	Operation Procedure
3. Remove the rear propeller housing and Remove the front propeller housing.		<ul style="list-style-type: none"> ●Loosen the fasteners that connect the rear propeller housing with the front propeller housing and remove the rear propeller housing. ●Use a screwdriver to unscrew the front propeller housing and then remove the propeller housing.
4. Remove the motor.		<ul style="list-style-type: none"> ●Remove the motor from the support and remove the louver from the motor axle. Then, remove the motor.
5. Install a new motor.		<ul style="list-style-type: none"> ●Assemble units based on the reverse order of this procedure and power on the units for test.

GMV-NX224P/A(X2.0)-M, GMV-NX280P/A(X2.5)-M, GMV-NX280P/A(X3.0)-M:

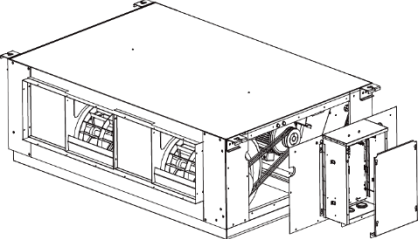
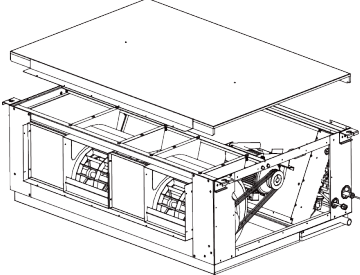
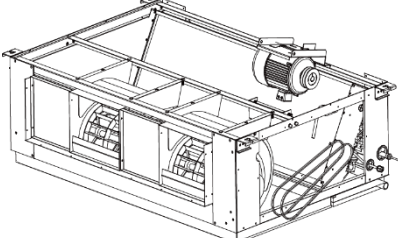
Motor and fan		
Precondition: The power supply has been disconnected.		
Step	Diagram	Operation Procedure
1.Remove the line connecting to the motor.		<ul style="list-style-type: none"> ●Use a screwdriver to unscrew the electric box cover. ●Remove from the master board the line connecting to the motor and remove the tie.
2. Remove the cover plate assembly		<ul style="list-style-type: none"> ●Use a screwdriver to unscrew the bolt to fixture the cover plate.
3. loosen the strap, Remove the motor cover plate		<ul style="list-style-type: none"> ●loosen the strap, Use a screwdriver to unscrew the bolt to fixture the cover plate.

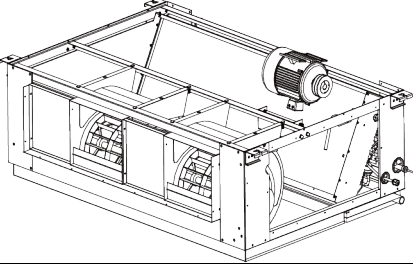
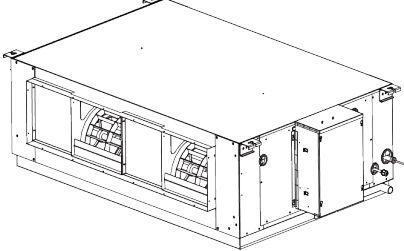
Motor and fan		
Precondition: The power supply has been disconnected.		
Step	Diagram	Operation Procedure
4. Remove the motor.		<ul style="list-style-type: none"> ●Remove the motor from the support and remove the louver from the motor axle. Then, remove the motor.
5. Install a new motor.		<ul style="list-style-type: none"> ●Assemble units based on the reverse order of this procedure and power on the units for test.

GMV-NX450P/A(X4.0)-M:

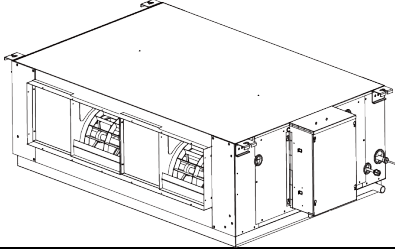
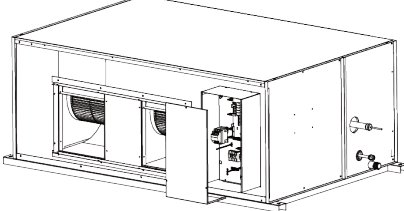
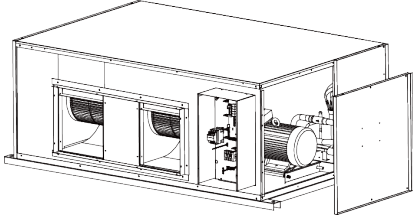
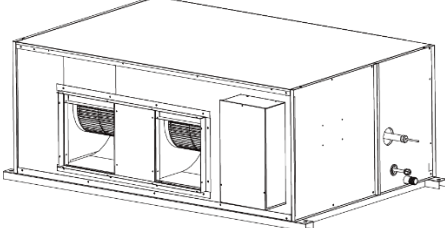
Motor and fan		
Precondition: The power supply has been disconnected.		
Step	Diagram	Operation Procedure
1. Remove the line connecting to the motor.		<ul style="list-style-type: none"> ●Use a screwdriver to unscrew the electric box cover. ●Remove from the master board the line connecting to the motor and remove the tie.
2. Remove the cover plate assembly		<ul style="list-style-type: none"> ●Use a screwdriver to unscrew the bolt to fixture the cover plate
3. Remove the motor.		<ul style="list-style-type: none"> ●Remove the motor from the support and remove the centrifugal fan from the motor axle. Then, remove the motor. ●For motors that are accompanied with supports, the supports need removing as well
4. Install a new motor.		<ul style="list-style-type: none"> ●Assemble units based on the reverse order of this procedure and power on the units for test.

GMV-NDX125P/A-T, GMV-NDX140P/A-T:

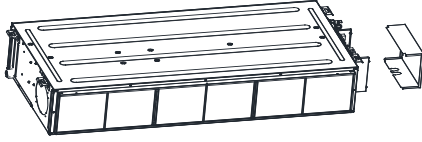
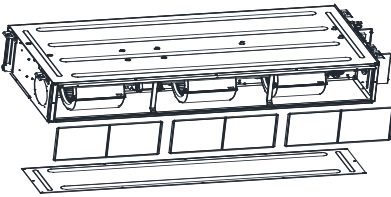
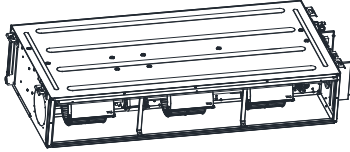
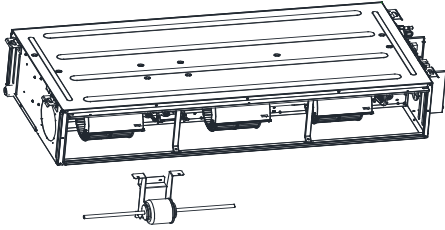
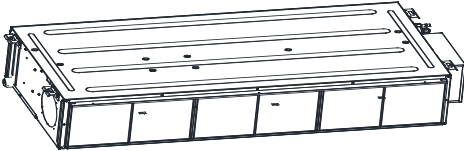
Motor and fan		
Precondition: The power supply has been disconnected.		
Step	Diagram	Operation Procedure
1. Remove the line connecting to the motor.		<ul style="list-style-type: none"> ●Use a screwdriver to unscrew the electric box cover. ●Remove from the master board the line connecting to the motor and remove the tie.
2. Remove the filter. And the air return cover plate.		<ul style="list-style-type: none"> ●Remove the filter from the air return frame. ●Use a screwdriver to unscrew the air return cover plate.
3. Remove the rear propeller housing and Remove the front propeller housing.		<ul style="list-style-type: none"> ●Loosen the fasteners that connect the rear propeller housing with the front propeller housing and remove the rear propeller housing. ●Use a screwdriver to unscrew the front propeller housing and then remove the propeller housing.
4. Remove the motor.		<ul style="list-style-type: none"> ●Remove the motor from the support and remove the louver from the motor axle. Then, remove the motor.
5. Install a new motor.		<ul style="list-style-type: none"> ●Assemble units based on the reverse order of this procedure and power on the units for test.

GMV-NDX224P/A-T, GMV-NDX250P/A-T, GMV-NDX280P/A-T:

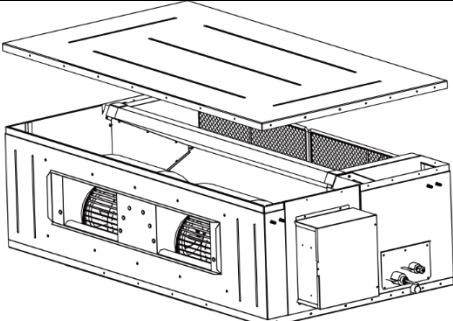
Motor and fan		
Precondition: The power supply has been disconnected.		
Step	Diagram	Operation Procedure
1. Remove the cover plate component.		<ul style="list-style-type: none"> ●Use a screwdriver to unscrew the cover plate component.

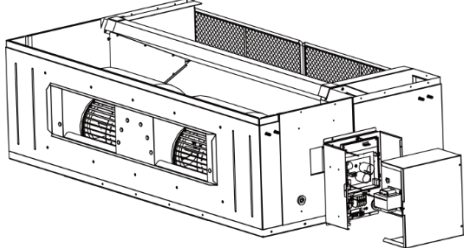
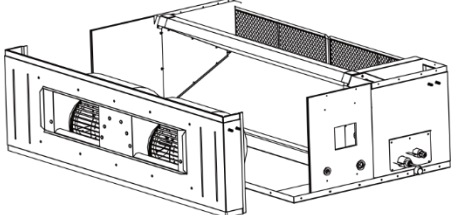
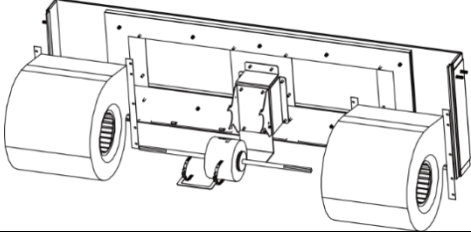
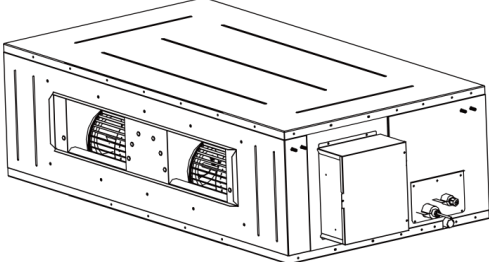
Motor and fan		
Precondition: The power supply has been disconnected.		
Step	Diagram	Operation Procedure
2. Remove the line connecting to the motor.		<ul style="list-style-type: none"> ●Use a screwdriver to unscrew the electric box cover. ●Remove from the master board the line connecting to the motor and remove the tie.
3. Disassemble the centrifugal fan.		<ul style="list-style-type: none"> ●Use a screwdriver to unscrew the centrifugal fan.
4. Remove the centrifugal fan.		<ul style="list-style-type: none"> ●Use a hexagon to unscrew the centrifugal fan and remove the centrifugal louver from the motor axle.
5. Install a new motor.		<ul style="list-style-type: none"> ●Assemble units based on the reverse order of this procedure and power on the units for test.

4.11 Slim Duct Type

Note:

The following steps are specific for GMV-ND22PL/B-T units. For other units, the assembly and disassembly procedure is similar except the numbers of louvers and motors.

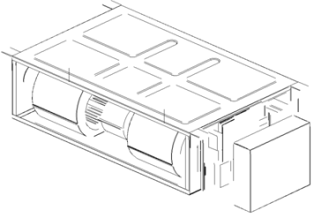
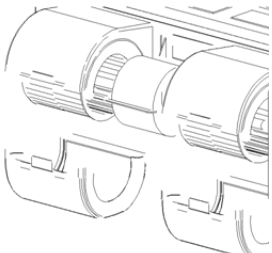
Motor and fan		
Precondition: The power supply has been disconnected.		
Step	Diagram	Operation Procedure
1. Remove the cover plate of the electric box.		<ul style="list-style-type: none"> ●Disconnect the power supply of the IDUs, use a screwdriver to unscrew the cover plate of the electric box, and then remove the line connecting to the motor.
2. Remove the rear volute casing.		<ul style="list-style-type: none"> ●Loosen the fasteners that connect the rear volute casing with the front volute casing and remove the rear volute casing.

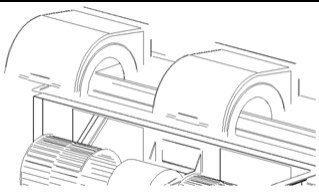
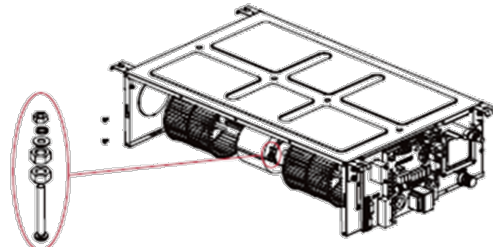
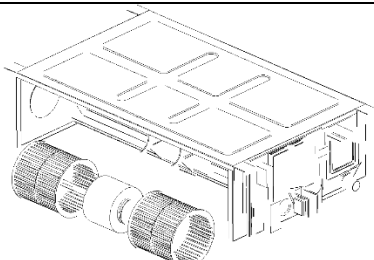
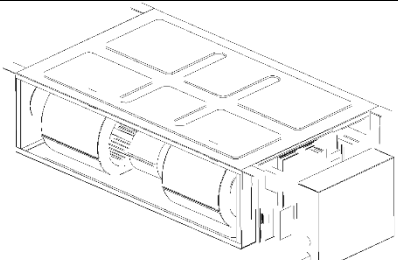
Motor and fan		
Precondition: The power supply has been disconnected.		
Step	Diagram	Operation Procedure
3. Remove the front volute casing.		<ul style="list-style-type: none"> ●Use a screwdriver to unscrew the front volute casing and then remove the volute casing.
4. Remove the louver and motor.		<ul style="list-style-type: none"> ●Use a screwdriver to unscrew the louver and loosen the fasteners of the motor.
5. Install a new motor.		<ul style="list-style-type: none"> ●Remove the motor from the support and remove the louver from the motor. Then, remove the motor. ●Install a new motor.
6. Install units in a reverse order of this procedure.		<ul style="list-style-type: none"> ●Assemble units based on the reverse order of this procedure and power on the units for test.

Note:

The following steps are specific for GMV-ND22PLS/C-T units. For other units, the assembly and disassembly procedure is similar except the numbers of louvers and motors.

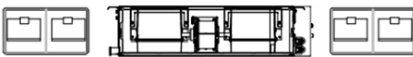
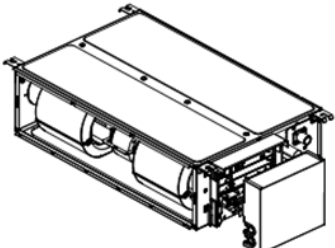
Motor and fan		
Precondition: The power supply has been disconnected.		
Step	Diagram	Operation Procedure
1. Remove the air return filter.		<ul style="list-style-type: none"> ●Draw the air return filter to both sides respectively at the return air inlet.
2. Remove the cover plate of the electric box.		<ul style="list-style-type: none"> ●Disconnect the power supply of the IDUs, use a screwdriver to unscrew the cover plate of the electric box, and then remove the line connecting to the motor.

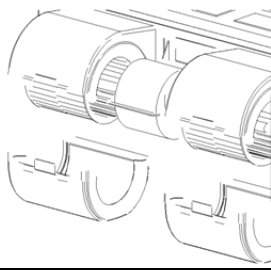
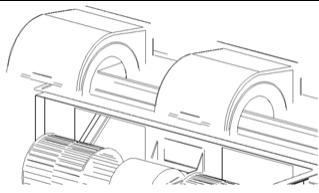
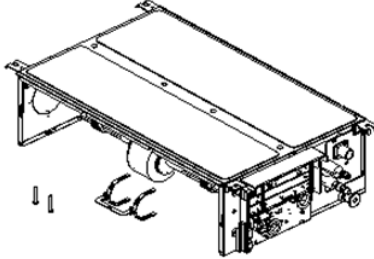
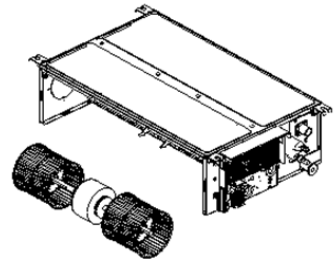
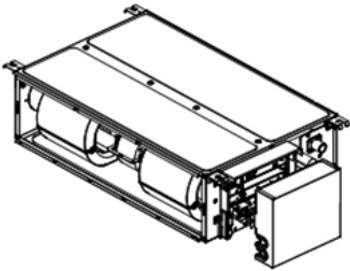
Motor and fan		
Precondition: The power supply has been disconnected.		
Step	Diagram	Operation Procedure
3. Remove the rear volute casing.		<ul style="list-style-type: none"> ●Loosen the fasteners that connect the rear volute casing with the front volute casing and remove the rear volute casing.
4. Remove the front volute casing.		<ul style="list-style-type: none"> ●Use a screwdriver to unscrew the front volute casing and then remove the volute casing.
5. Remove the louver and motor.		<ul style="list-style-type: none"> ●Use a screwdriver to unscrew the louver and loosen the fasteners of the motor.
6. Install a new motor.		<ul style="list-style-type: none"> ●Remove the motor from the support and remove the louver from the motor. Then, remove the motor. ●Install a new motor.
7. Install units in a reverse order of this procedure.		<ul style="list-style-type: none"> ●Assemble units based on the reverse order of this procedure and power on the units for test.

4.12 Console Type Indoor Unit

Note:

The following steps are specific for GMV-ND22C/A-T units. For other units, the assembly and disassembly procedure is similar except the numbers of louvers and motors.

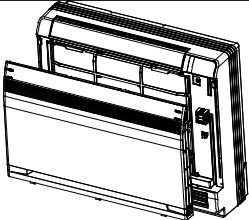
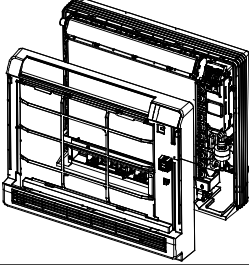
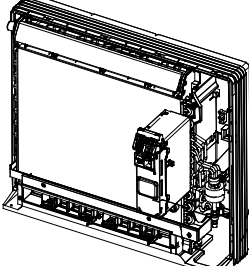
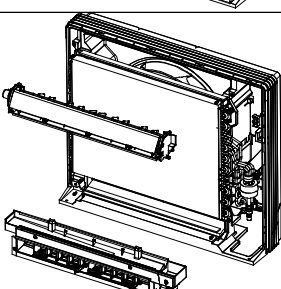
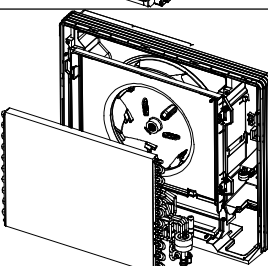
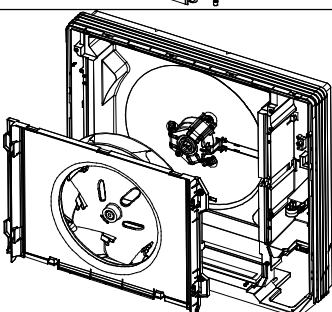
Removal of Fan Motor		
Remark: before removing, making sure power is disconnected.		
Step	Diagram	Operation Procedure
1. Open the panel		<ul style="list-style-type: none"> ● Press clasps at both sides to "OPEN" position.
2. Remove filter and front case		<ul style="list-style-type: none"> ● Remove 5 screws fixing the front case.
3. Remove electric box		<ul style="list-style-type: none"> ● Open electric box cover, loosen all connection wires and then remove screws.
4. Remove water tray and swing motor		<ul style="list-style-type: none"> ● Remove 2 screws fixing water tray and swing motor respectively.
5. Remove evaporator		<ul style="list-style-type: none"> ● Remove the fixer fixing the evaporator, press 2 clasps at left side and then remove the evaporator.
6. Remove reversion loop and centrifugal blade		<ul style="list-style-type: none"> ● Remove 4 screws fixing the reversion loop and then remove the reversion loop' remove nuts on blade and then remove the centrifugal blade.

4.13 Wall Mounted type Indoor Unit

Note:

The following steps are specific for GMV-N22G/A3A-K units. For other units, the assembly and disassembly procedure is similar except the numbers of louvers and motors.

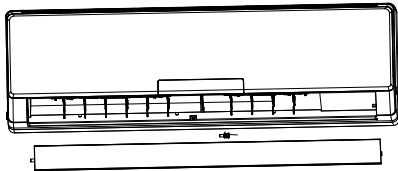
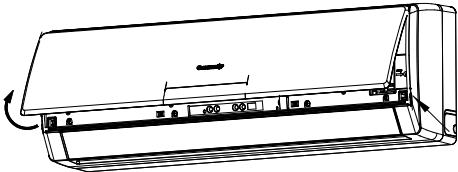
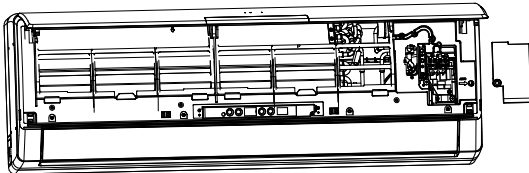
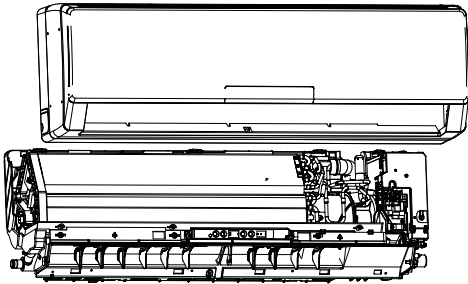
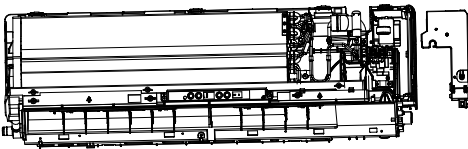
Removal of Fan Motor		
Remark: before removing, making sure power is disconnected.		
Step	Diagram	Operation Procedure
1. Remove the louver		<ul style="list-style-type: none"> ●Take off the axle bush of the louver. ●Remove the louver.
2. Open the front panel		<ul style="list-style-type: none"> ●Hold the indents on both sides of the panel and pull it out in the direction shown by the arrow.
3. Remove the electrical box cover 2		<ul style="list-style-type: none"> ●Unscrew the screws fixing the electrical box cover with a screwdriver. Take off the box cover 2. ●Detach the ambient temperature sensor from the conduit.
4. Remove the front panel assembly		<ul style="list-style-type: none"> ●Unscrew the screws fixing the front panel assembly. ●Remove the front panel assembly.
5. Remove the electrical box cover 1		<ul style="list-style-type: none"> ●Press on the buckle of the box cover 1 and then take off the cover.

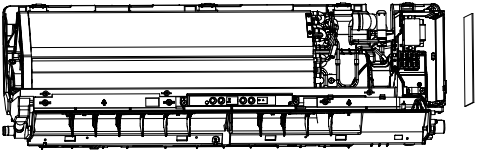
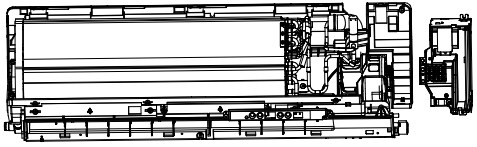
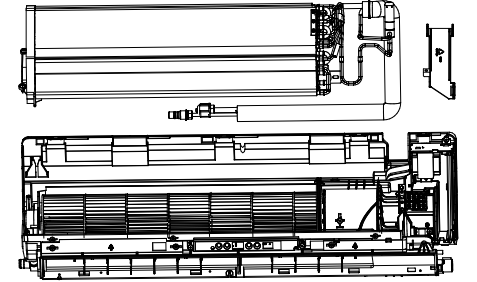
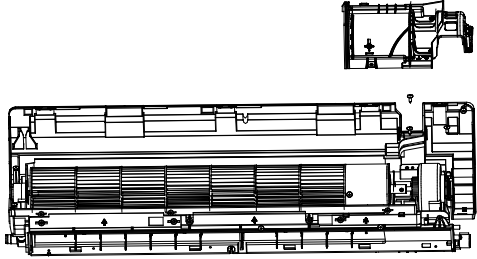
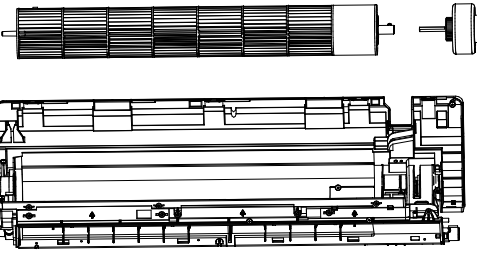
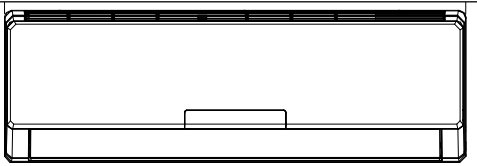
Removal of Fan Motor		
Remark: before removing, making sure power is disconnected.		
Step	Diagram	Operation Procedure
6. Remove the main board		<ul style="list-style-type: none"> ●Release the wiring terminals connected to the main board. ●Remove the main board.
7. Remove the electrical box		<ul style="list-style-type: none"> ●Unscrew the screws fixing the electrical box with a screwdriver. ●Remove the electrical box.
8. Remove the evaporator		<ul style="list-style-type: none"> ●Use a screwdriver to unscrew the screws fixing the press plate of connection pipe on the back of the unit and take off the press plate. ●Unscrew the screws of evaporator with a screwdriver and then remove the evaporator.
9. Remove motor's pressing plate		<ul style="list-style-type: none"> ●Unscrew the fixing screws of the pressing plate with a screwdriver and then remove it.
10. Remove the motor and fan		<ul style="list-style-type: none"> ●Take off the motor and fan directly. ●Use a screwdriver to unscrew the screws connecting the motor and the fan.
11. Install a new motor.		<ul style="list-style-type: none"> ●Assemble units based on the reverse order of this procedure and power on the units for test.

4.14 Super High Static Pressure Duct Type Indoor Unit

Note:

The following steps are specific for GMV-ND22PHS/B-T units. For other units, the assembly and disassembly procedure is similar except the specifications of centrifugal fans and motors.

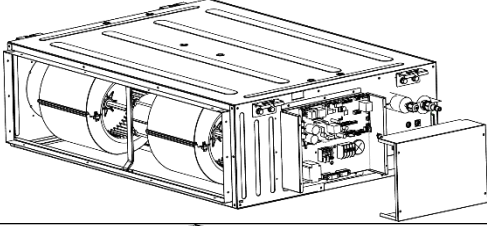
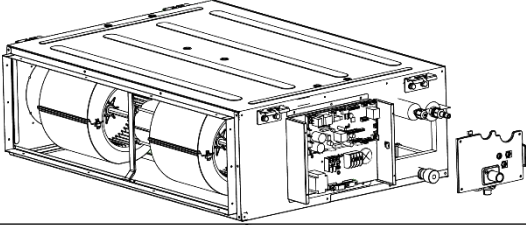
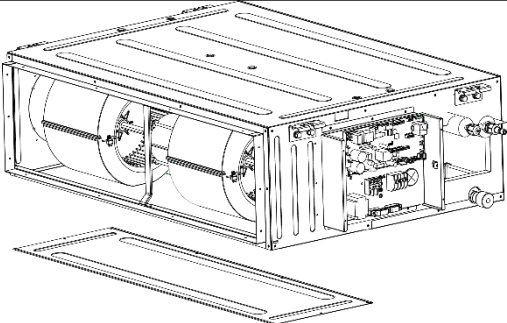
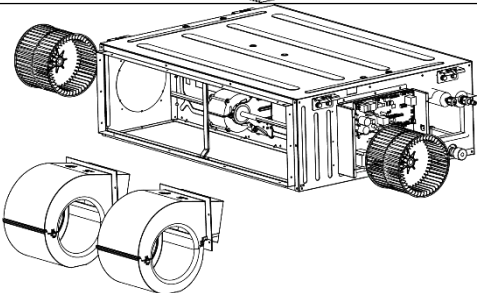
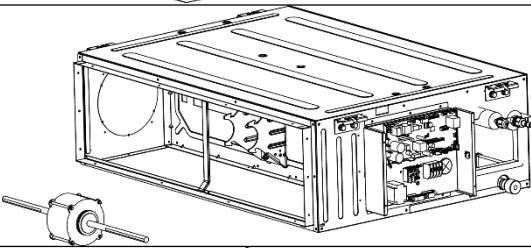
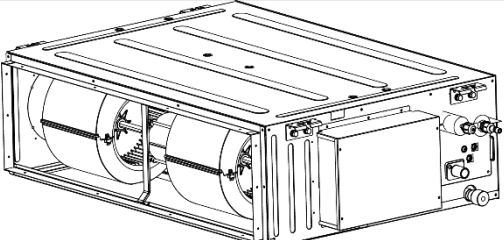
Motor and fan		
Precondition: The power supply has been disconnected.		
Step	Diagram	Operation Procedure
1. Remove the line connecting to the motor.		<ul style="list-style-type: none"> ●Use a screwdriver to unscrew the electric box cover. ●Remove from the master board the line connecting to the motor and remove the tie.
2. Disassemble the seal plate and cover plate.		<ul style="list-style-type: none"> ●Use a screwdriver to unscrew the seal plate and cover plate and then remove them.
3. Remove the grille		<ul style="list-style-type: none"> ●Use a screwdriver to unscrew the cover plate component.
4. Remove the centrifugal fan.		<ul style="list-style-type: none"> ●Use a screwdriver to unscrew the front volute casing and then remove the volute casing.
5. Remove the motor.		<p>Remove the motor from the support and remove the centrifugal fan from the motor axle. Then, remove the motor.</p> <ul style="list-style-type: none"> ●For motors that are accompanied with supports, the supports need removing as well.
6. Install a new motor.		<ul style="list-style-type: none"> ●Assemble units based on the reverse order of this procedure and power on the units for test.

Note: The following steps are specific for GMV-ND450PH/AR-X units. For other units, the assembly and disassembly procedure is similar except the specifications of centrifugal fans and motors.

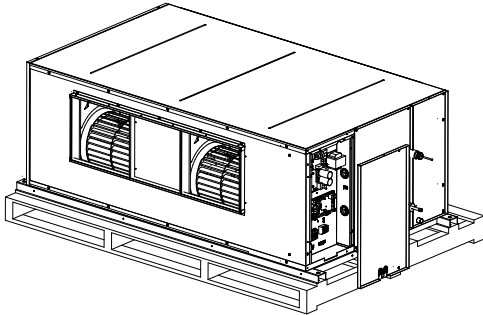
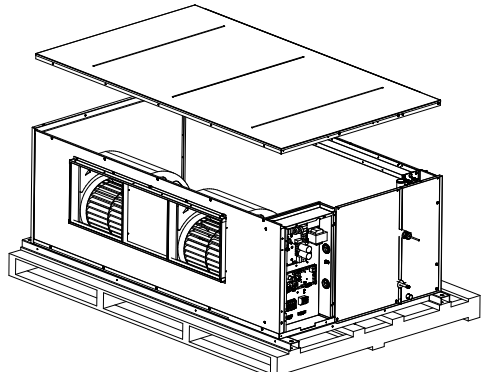
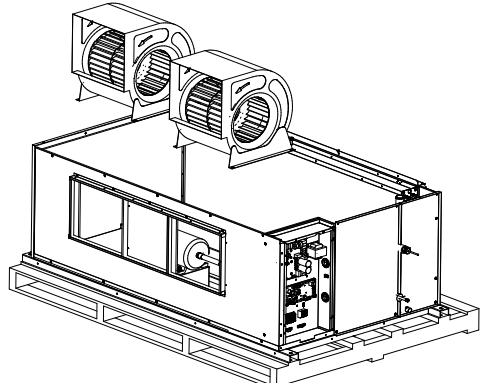
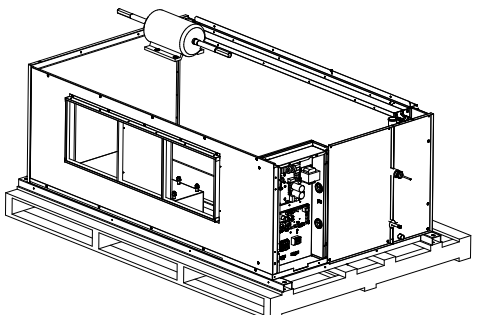
Motor and fan		
Precondition: The power supply has been disconnected.		
Step	Diagram	Operation Procedure
1. Remove the line connecting to the motor.		<ul style="list-style-type: none"> ●Use a screwdriver to unscrew the electric box cover. ●Remove from the master board the line connecting to the motor and remove the tie.
2. Disassemble the cover plate.		<ul style="list-style-type: none"> ●Use a screwdriver to unscrew the cover plate and then remove them.
3. Remove the centrifugal fan.		<ul style="list-style-type: none"> ●Use a screwdriver to unscrew the front volute casing and then remove the volute casing.
4. Remove the motor.		<p>Remove the motor from the support and remove the centrifugal fan from the motor axle. Then, remove the motor.</p> <ul style="list-style-type: none"> ●For motors that are accompanied with supports, the supports need removing as well.

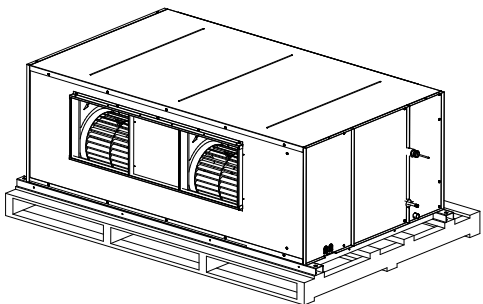
Motor and fan		
Precondition: The power supply has been disconnected.		
Step	Diagram	Operation Procedure
5. Install a new motor.		<ul style="list-style-type: none"> ●Assemble units based on the reverse order of this procedure and power on the units for test.

4.15 Concealed Floor Standing Type

Note:

The following steps are specific for GMV-ND56ZA/A-T units. For other units, the assembly and disassembly procedure is similar except the specifications of centrifugal fans and motors.

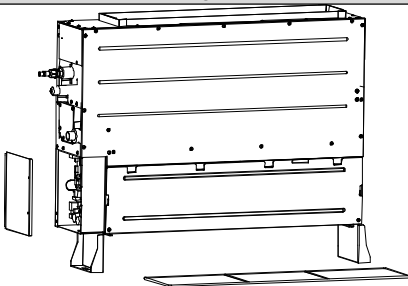
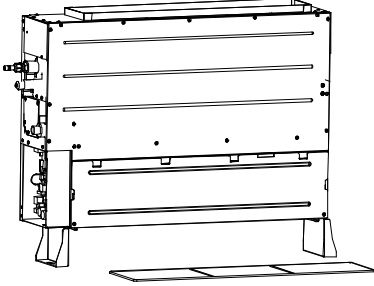
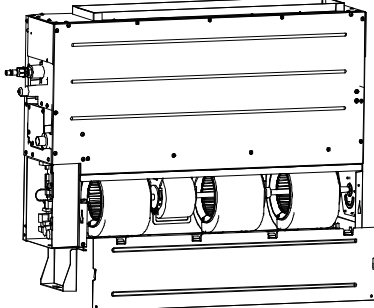
Motor and fan		
Precondition: The power supply has been disconnected.		
Step	Diagram	Operation Procedure
1. Remove the line connecting to the motor.		<ul style="list-style-type: none"> ●Use a screwdriver to unscrew the electric box cover. ●Remove from the master board the line connecting to the motor and remove the tie.
2. Remove the filter.		<ul style="list-style-type: none"> ●Remove the filter from the air return frame.
3. Remove the air return cover plate.		<ul style="list-style-type: none"> ●Use a screwdriver to unscrew the air return cover plate.

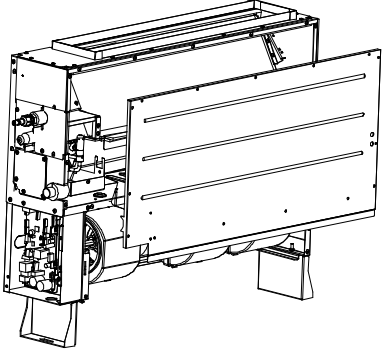
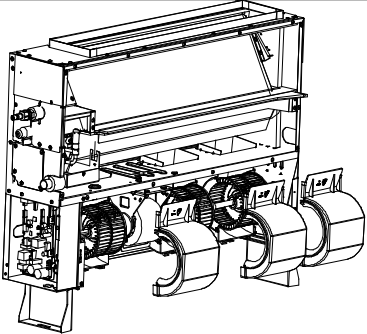
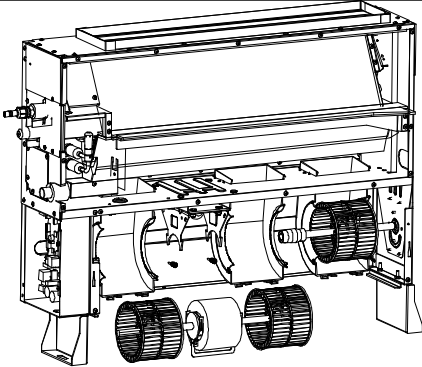
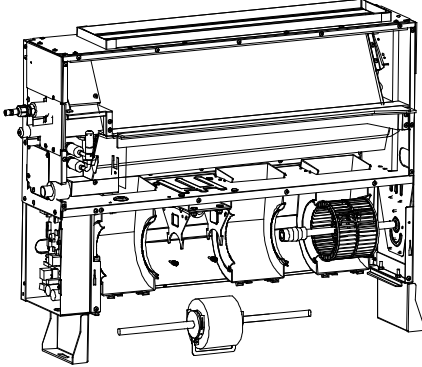
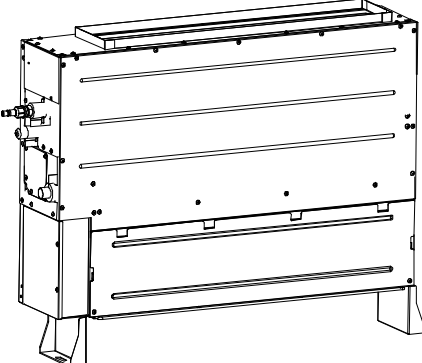
Motor and fan		
Precondition: The power supply has been disconnected.		
Step	Diagram	Operation Procedure
4. Remove the bottom cover plate.		<ul style="list-style-type: none"> ●Use a screwdriver to unscrew the air return cover plate.
5. Remove the rear volute casing.		<ul style="list-style-type: none"> ●Loosen the fasteners that connect the rear volute casing with the front volute casing and remove the rear volute casing.
6. Loosen the centrifugal fan and motor.		<ul style="list-style-type: none"> ●Use a hexagon to unscrew the centrifugal fan and loosen the fasteners of the motor.
7. Remove the motor.		<ul style="list-style-type: none"> ●Remove the motor from the support and remove the centrifugal fan from the motor axle. Then, remove the motor. ●For motors that are accompanied with supports, the supports need removing as well.
8. Install a new motor.		<ul style="list-style-type: none"> ●Assemble units based on the reverse order of this procedure and power on the units for test.

4.16 360° Air Discharge Cassette Type

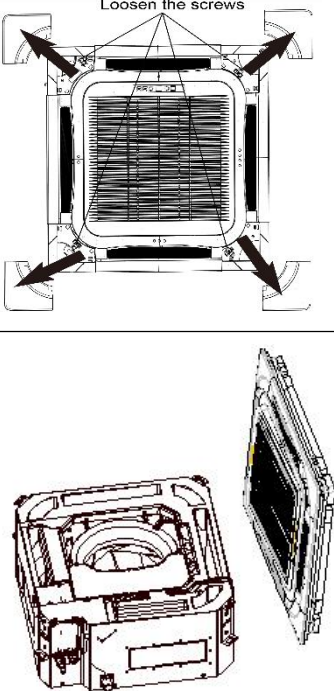
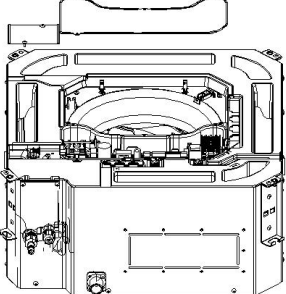
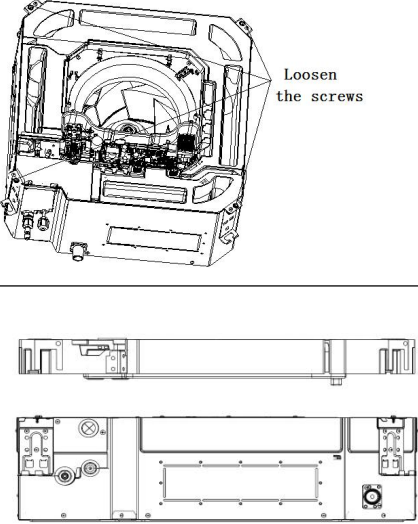
Motor and fan		
Step	Diagram	Operation Procedure
1. Remove the front panel.		<ul style="list-style-type: none"> ● Turn off the power supply of indoor unit. ● Push the 4 corner plates in the directions shown by the arrows. ● Loosen the screws and remove the front panel.
2. Remove the cover of electric box and the clamp of power cord.		<ul style="list-style-type: none"> ● Remove the motor wire and water pump of the electric box.
4. Remove the water tray.		<ul style="list-style-type: none"> ● Loosen the screws in the 4 corners and then remove the water tray.

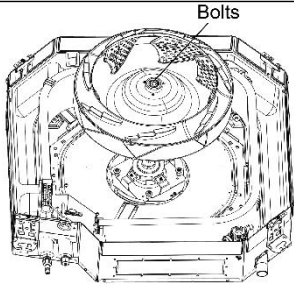
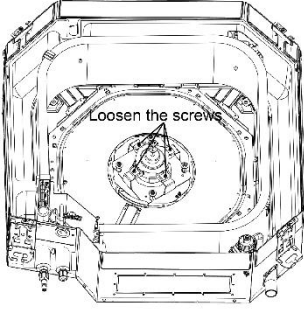
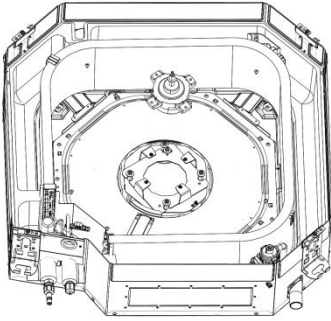
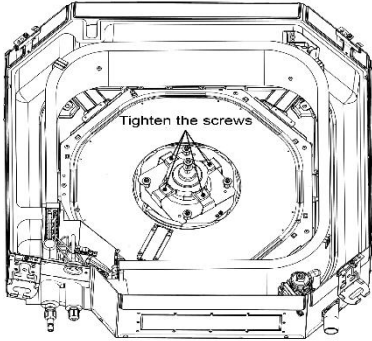
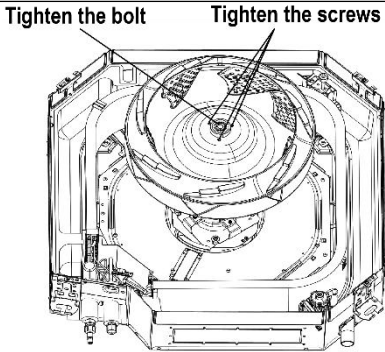
Motor and fan		
Step	Diagram	Operation Procedure
5. Remove the fan.		<ul style="list-style-type: none"> ●Use a screwdriver to remove the clamping band of motor. Then remove the fan.
6. Remove motor.		<ul style="list-style-type: none"> ●Use a screwdriver to unscrew the 4 screws of motor. Then remove the motor.
		
7. Replace and install the motor.		<ul style="list-style-type: none"> ●Remove the motor from motor support and then replace with a new motor. ●Tighten the 4 screws of motor with a screwdriver.
8. Install the fan.		<ul style="list-style-type: none"> ●Direct the hole of fan to the motor shaft and then mount on the fan. ●Tighten the clamping band of motor with a wrench.

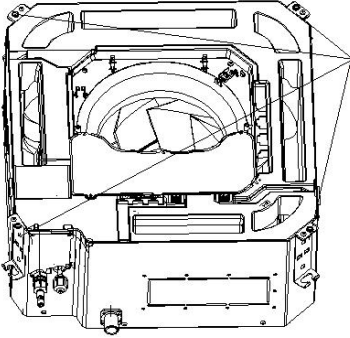
Motor and fan		
Step	Diagram	Operation Procedure
9. Install the water tray.	 <p>Tighten the screws</p>	<ul style="list-style-type: none"> ●Direct the 4 corners of water tray to the 4 corners of the unit and then press them. Use a screwdriver to tighten the screws in the 4 corners. ●Connect the power cord and water pump wire. ●Place back the cover of electric box and the clamp of power cord. Then tighten the screws with a screwdriver.

5 Exploded Views and Part List

5.1 Floor Standing Type

Exploded View of GMV-ND100L/A-T, GMV-ND140L/A-T:

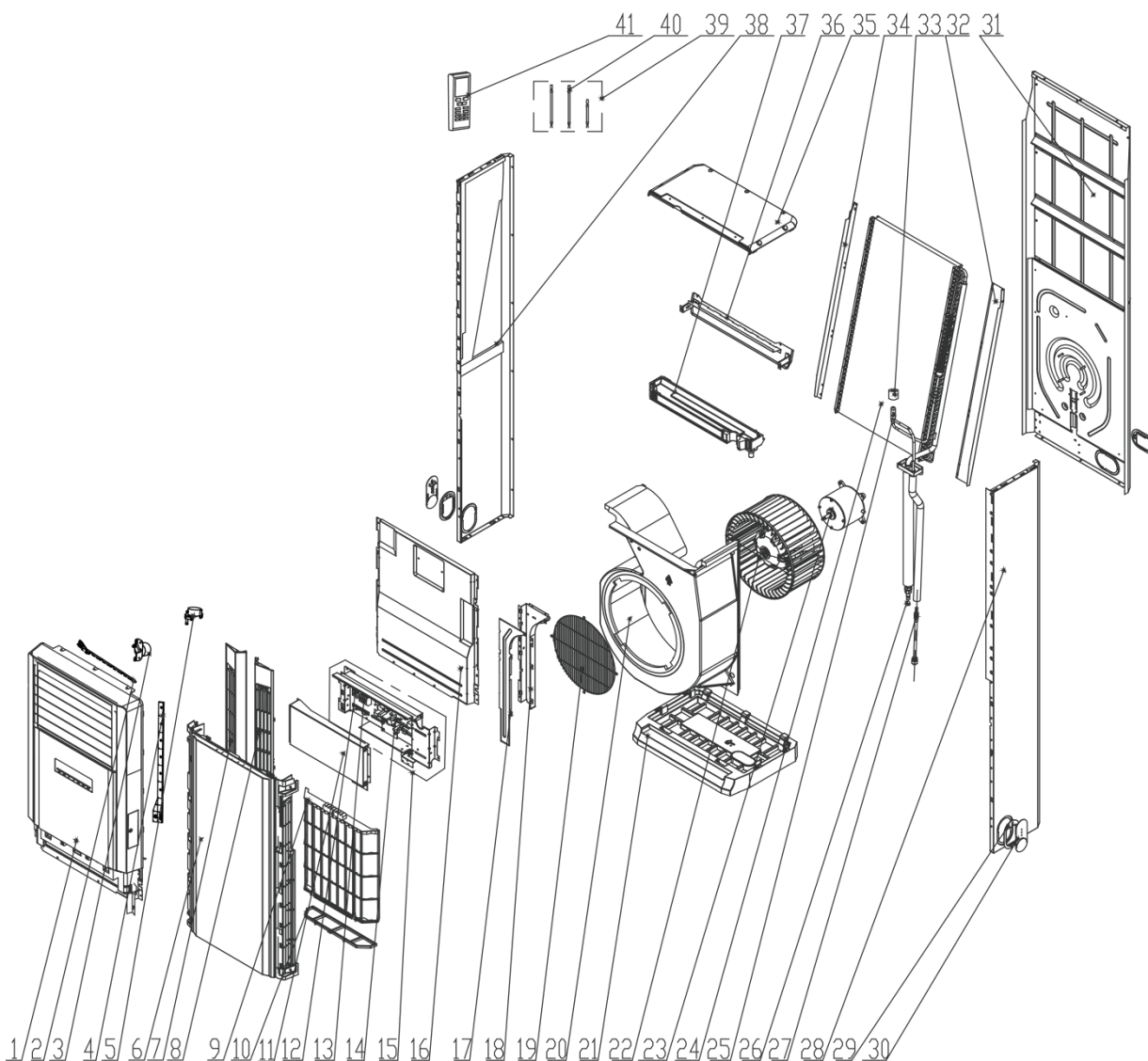

NO	Model	GMV-ND100L/A-T	GMV-ND140L/A-T	Qty
	Product Code	CM300N0060	CM300N0070	
	Part Name	Part Code	Part Code	
1	Air Outlet Panel Assy	20004505	20004505	1

NO	Model	GMV-ND100L/A-T	GMV-ND140L/A-T	Qty
	Product Code	CM300N0060	CM300N0070	
	Part Name	Part Code	Part Code	
2	Swing Lever	10584218	10584218	1
3	Stepping Motor	15214005	15214005	1
4	Guide blade Lever	10584089	10584089	1
5	Stepping Motor	1521400803	1521400803	1
6	Air Intake Panel Assy	20004536	20004536	1
7	Left Side board	0130451901	0130430401	1
8	Right Side Plate of Air Inlet	0130451801	0130430301	1
9	Filter Sub-Assy(Upper)	11124100	11124100	1
10	Filter(Lower)	11124012	11124012	2
11	Electric Box Cover Sub-Assy	01404388	01404388	1
12	Terminal Board	42010259	42010259	1
13	Terminal Board	4201800002601	4201800002601	1
14	Main Board	30226000004	30226000004	1
15	Electric Box Assy	02404122	02404122	1
16	Air Guard Assy	01354100012	01354100012	1
17	Cover of Pass Wire slot	01744109	01744109	1
18	Pass Wire slot	02164010	02164010	
19	Protective Covering	01474027	01474027	1
20	Propeller Housing	12104057	12104057	1
21	Chassis	22224020	22224020	1
22	Centrifugal Fan	10314401	10314401	1
23	Fan Motor	1501442502	1501442502	1
24	Evaporator Sub-Assy	01034024	01034054	1
25	Electronic Expansion Valve	07334468	07334468	1
26	Filter Sub-Assy	07210028	07210028	2
27	Strainer	07213050	07213050	
28	Right Side Plate Sub-Assy	0130451801	0130451801	1
29	Rear Cover	2224422101	2224422101	3
30	Baffle Plate	2611408801	2611408801	3
31	Rear Plate Sub-Assy	01304500	01304500	1
32	Right Air Guard	01364507	01364507	1
33	Electronic Expansion Valve Fitting	4304413219	4304413219	1
34	Left Air Guard	01364506	01364506	
35	Top Cover Sub-Assy	01364506	01364506	1
36	Breakwater Sub-Assy	01364154P	01364154P	1
37	Water Tray Sub-Assy	12314811	12314811	1
38	Left Side Plate Sub-Assy	0130451901	0130451901	
39	Sensor Sub-Assy	39008000115G	39008000115G	1
40	Temp Sensor	34030048	34030048	1
41	Remote Controller	30510589	30510589	1

Above data is subject to change without notice, pls reference the SP in global service website.

5.2 High Static Pressure Duct Type

Exploded View of GMV-ND56PHS/A-T, GMV-ND63PHS/A-T, GMV-ND71PHS/A-T,
GMV-ND80PHS/A-T:

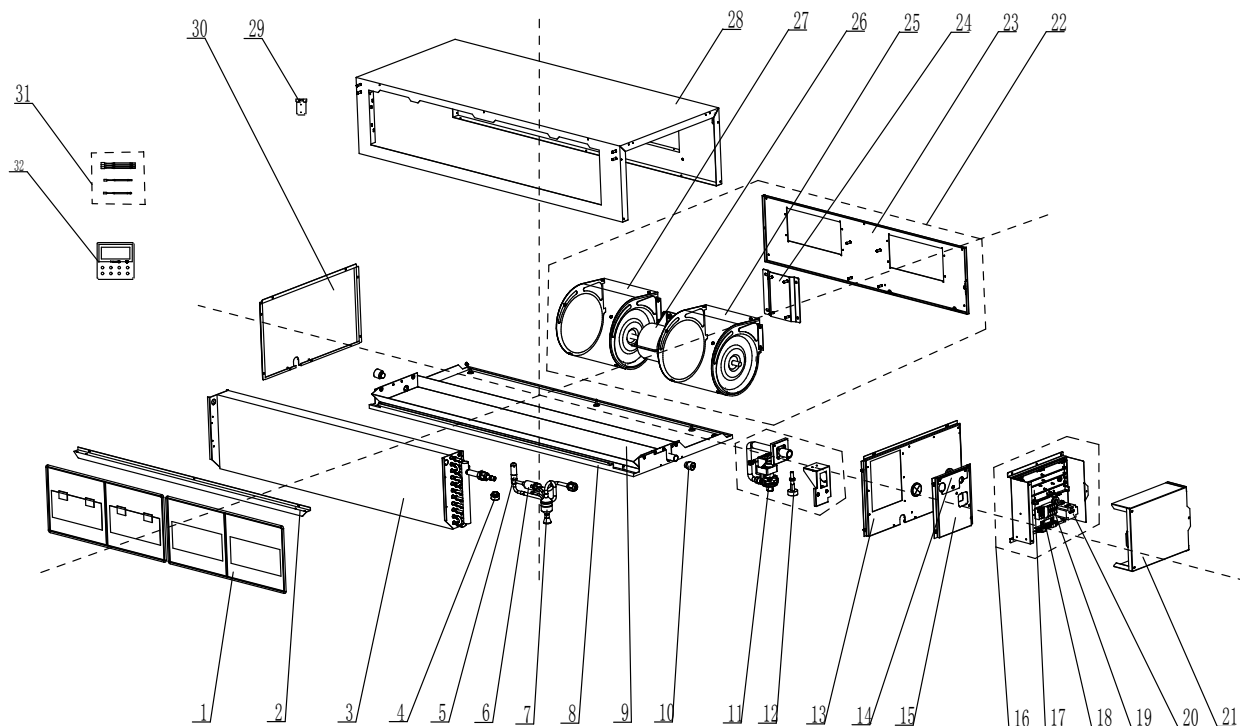

No.	Name of part	For the following unit	
		Unit	Product Code
		GMV-ND56PHS/A-T	CM800N3690
		GMV-ND63PHS/A-T	CM800N3700
		GMV-ND71PHS/A-T	CM800N3540
		GMV-ND80PHS/A-T	CM800N3710
		Part code	Quantity
1	Filter Sub-Assy	11125303	2
2	Guide groove of the filter screen	02285301	1
3	Evaporator Assy	01024100090	1
4	Electric Expand Valve Fitting	4304413215	1
5	Electronic Expansion Valve	07334466	1
6	Strainer	0741410000601	1
7	Filter	07415210	1
8	Lower Cover Plate Sub-Assy	01265304	1
9	Water Tray Assy	01285317	1
10	Choke Plug of Drain Pipe	76712455	2
11	Water Pump	4313822001	1
12	Water Level Switch	450127011	1
13	Right Side Plate	01314100063	1
14	Seal plate	01494100008	1
15	Cover Plate	01264100036	1
16	Electric Box Assy	01394100255	1

No.	Name of part	For the following unit	
		Unit	Product Code
		GMV-ND56PHS/A-T	CM800N3690
		GMV-ND63PHS/A-T	CM800N3700
		GMV-ND71PHS/A-T	CM800N3540
		GMV-ND80PHS/A-T	CM800N3710
		Part code	Quantity
17	Main Board	30226000027	1
18	Terminal Board	42011154	1
19	Terminal Board	4201800002601	1
20	Inductance	43128000014	1
21	Electric Box Cover	01424100078	1
22	Centrifugal fan assy	15405200029	1
23	Blower Mounting Plate Sub-Assy	01325200039	1
24	Supporter	01804100140	1
25	Blower	15012454	1
26	Brushless DC Motor	15705200006	1
27	Blower	15012458	1
28	Top Cover Board Assy	01265226	1
29	Hook	02112446	4
30	Left Side Plate Assy	01314155	1
31	Sensor Sub-assy	39004169G	1
32	Display Board	30296000040	1

Above data is subject to change without notice, pls reference the SP in global service website.

Exploded View of GMV-ND90PHS/A-T, GMV-ND100PHS/A-T, GMV-ND112PHS/A-T,
GMV-ND125PHS/A-T, GMV-ND140PHS/A-T:

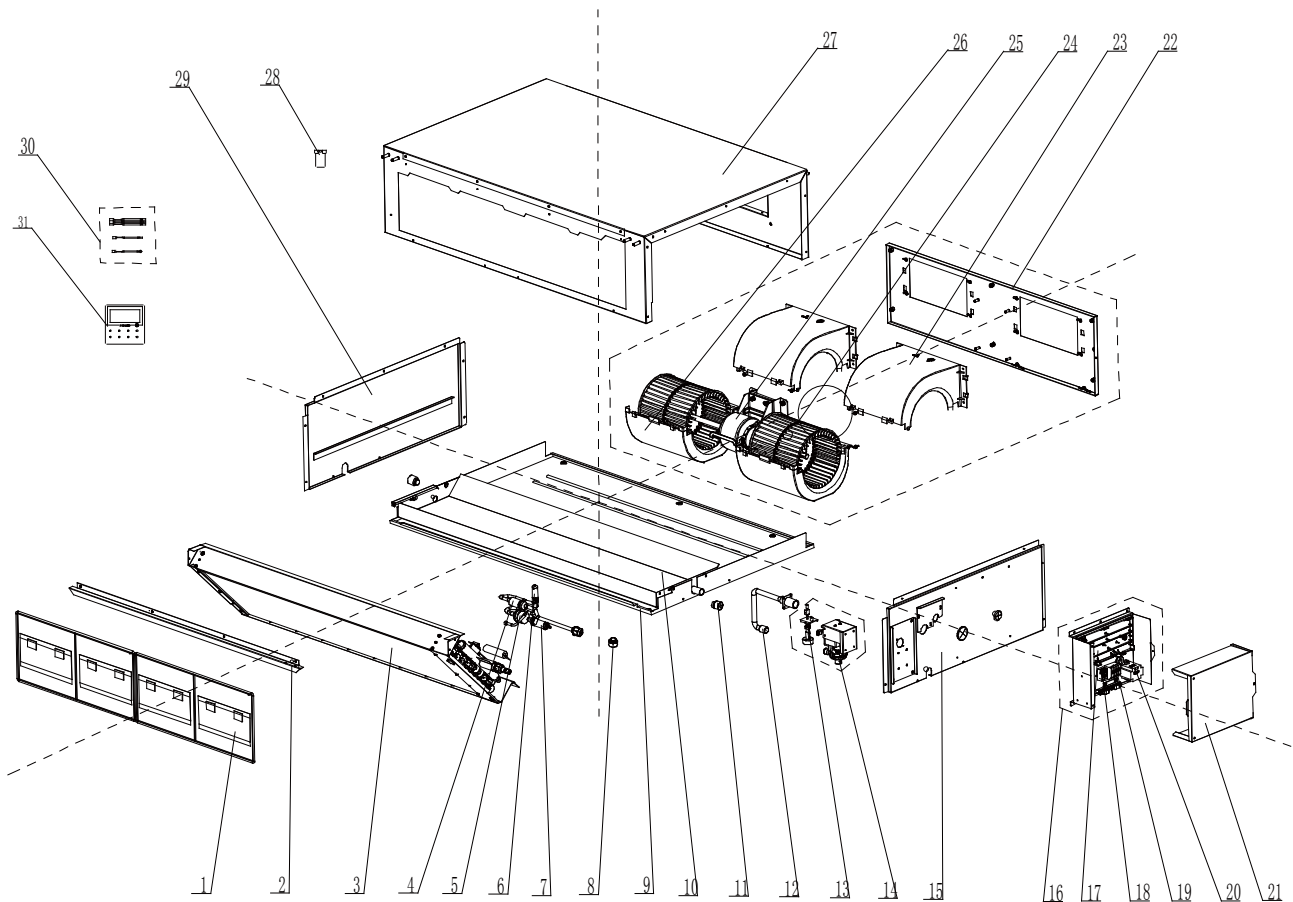

No.	Name of part	For the following unit	
		Unit	Product Code
		GMV-ND90PHS/A-T	CM800N3550
		GMV-ND100PHS/A-T	CM800N3650
		GMV-ND112PHS/A-T	CM800N3660
		GMV-ND125PHS/A-T	CM800N3670
		GMV-ND140PHS/A-T	CM800N3680
		Part code	Quantity
1	Filter Sub-Assy	111253031	2
2	Side Plate of Air intake	01375301	1
3	Evaporator Assy	01024100077	1
4	Strainer	0741410000601	2
5	Filter	0	0
6	Electronic Expansion Valve	07334468	1
7	Strainer	07220005	1
8	Electric Expand Valve Fitting	4304413215	1
9	Lower Cover Plate Sub-Assy	15265301	1
10	Water Tray Assy	01285323	1
11	Choke Plug of Drain Pipe	76712455	2
12	Pump Drainpipe	05235301	1

No.	Name of part	For the following unit	
		Unit	Product Code
		GMV-ND90PHS/A-T	CM800N3550
		GMV-ND100PHS/A-T	CM800N3650
		GMV-ND112PHS/A-T	CM800N3660
		GMV-ND125PHS/A-T	CM800N3670
		GMV-ND140PHS/A-T	CM800N3680
		Part code	Quantity
13	Water Level Switch	45018012	1
14	Water Pump	43138220	1
15	Right Side Plate Sub-Assy	01315200100	1
16	Electric Box Assy	01394100255	1
17	Main Board	30226000027	1
18	Terminal Board	42011154	1
19	Terminal Board	4201800002601	1
20	Inductance	43128000014	1
21	Electric Box Cover	01424100078	1
22	Blower Mounting Plate Sub-Assy	01325200044	1
23	Volute casing(Upper)	26904100051	2
24	Centrifugal Fan	10424100001	2
25	Brushless DC Motor	15709400006	1
26	Volute casing(Lower)	26904100052	2
27	Top Cover Board Assy	01264100039	1
28	Hook	02112466	4
29	Left Side Plate Assy	01315306	1
30	Sensor Sub-assy	39004169G	1
31	Display Board	30296000040	1

Above data is subject to change without notice, pls reference the SP in global service website.

Exploded View of GMV-ND160PHS/A-T:

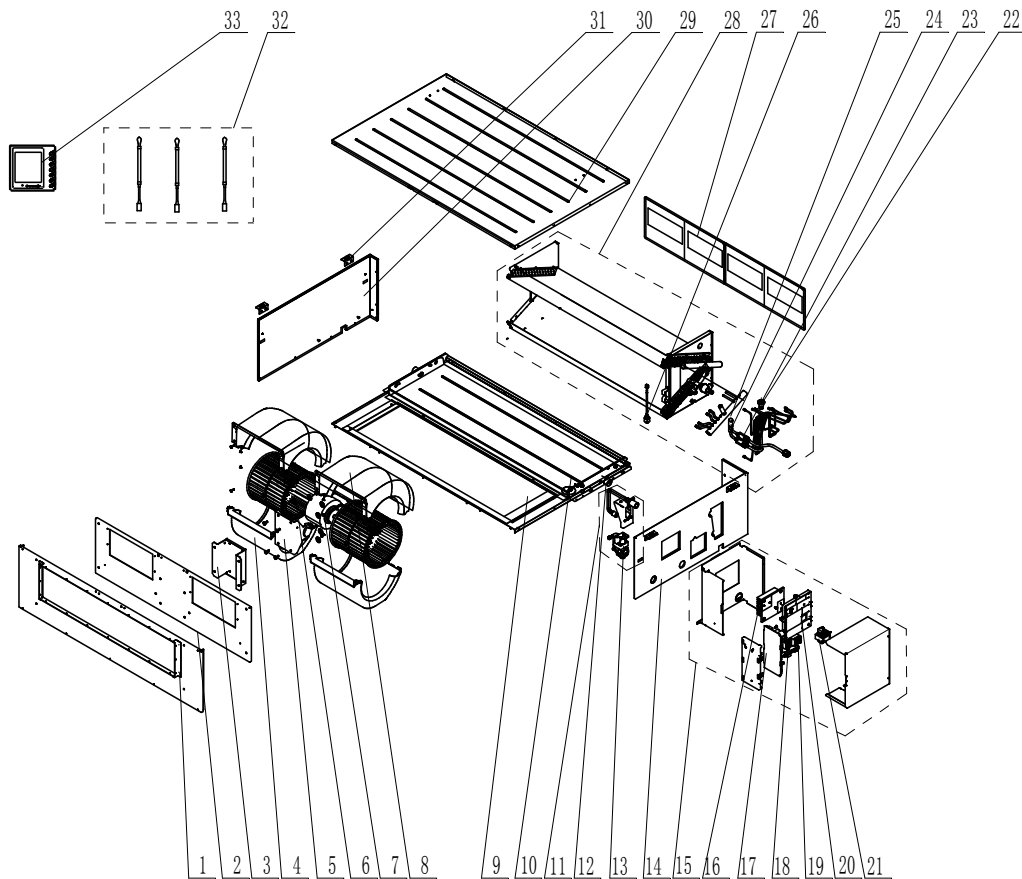

NO.	Model	GMV-ND160PHS/A-T	Qty.
	Product Code	CM810N0250	
	Part Name	Part Code	
1	Front Side Plate Sub-Assy	01315200091	1
2	Blower Mounting Plate Sub-Assy	01325200057	1
3	Support plate sub-assy (motor)	0189520001401	1
4	Propeller Housing(Lower)	26905200011	2
5	Motor Support	01805200228	1
6	Centrifugal Fan	10425200002	2
7	Brushless DC Motor	15709400008	1
8	Propeller Housing(Upper)	26905200010	2
9	Bottom Cover Plate Assy	01265200045	1
10	Water Tray Assy	01285200025	1
11	Water Pump Assy	15405200081	1
12	Choke Plug of Drain Pipe	76712455	2
13	Water Pump	4313822001	1
14	Right Side Plate Assy	01314100108	1
15	Electric Box Sub-Assy	01395200479	1
16	Radiator	49018000068	1
17	Main Board	30226000064	1
18	Terminal Board	42010259	1
19	Terminal Board	4201800002601	1
20	Main Board	30221000018	1
21	Reactor	43138000047	1

NO.	Model	GMV-ND160PHS/A-T	Qty.
	Product Code	CM810N0250	
	Part Name	Part Code	
22	Current Divider	07222706	1
23	Strainer	0741410000601	2
24	Electronic Expansion Valve	07334468	1
25	Electric Expand Valve Fitting	4304413215	1
26	Water Level Switch	4501270301	1
27	Filter Sub-Assy	111253036	2
28	Evaporator Assy	01024100157	1
29	Top Cover Board Assy	01265200081	1
30	Left Side Plate Sub-Assy	01315200064	1
31	Hook	02205209	4
32	Sensor Sub-assy	39008000103G	1
33	Display Board	30296000040	1

Above data is subject to change without notice, pls reference the SP in global service website.

GMV-ND224PH/A-T:

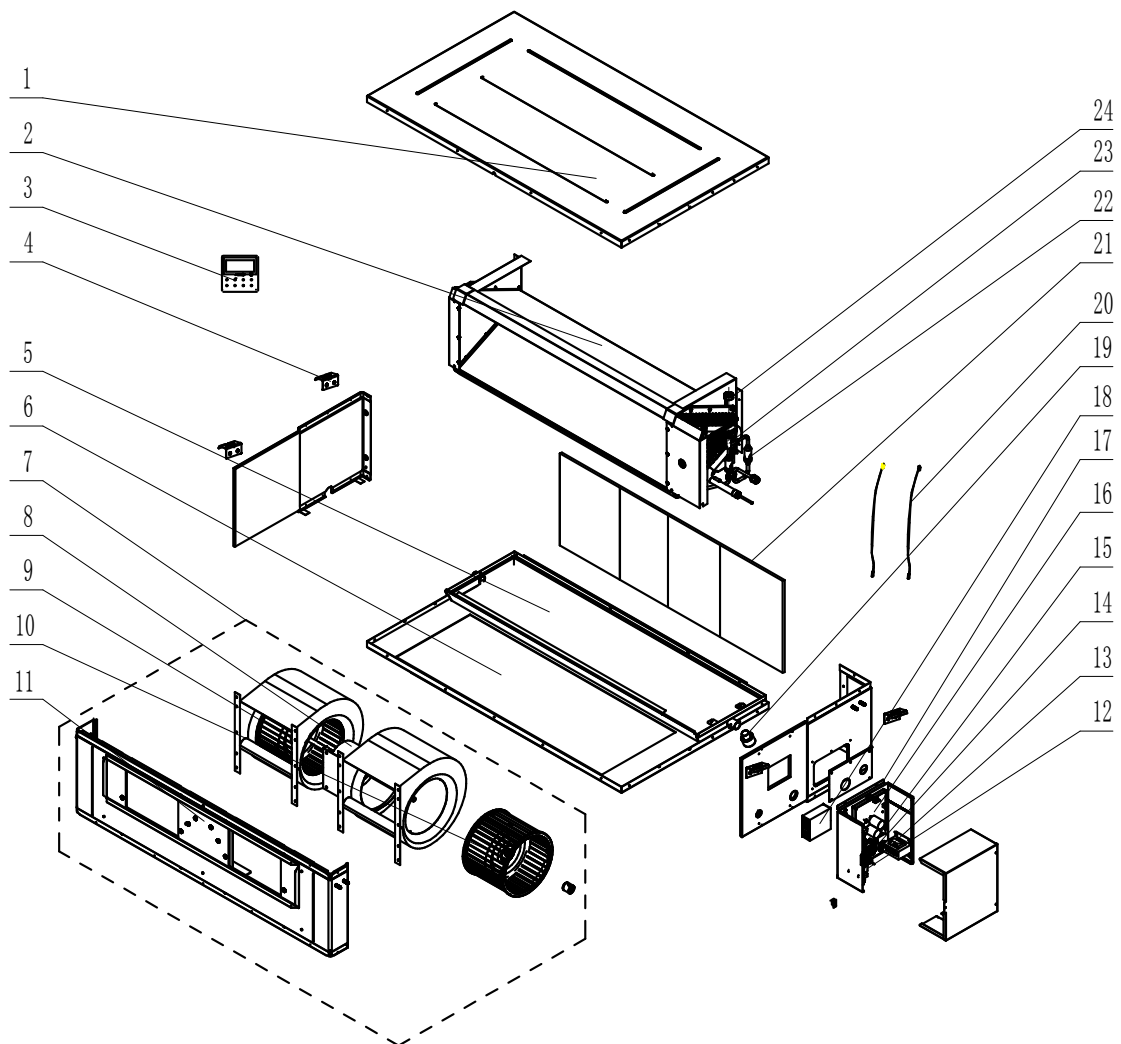

Exploded View of GMV-ND280PH/A-T:

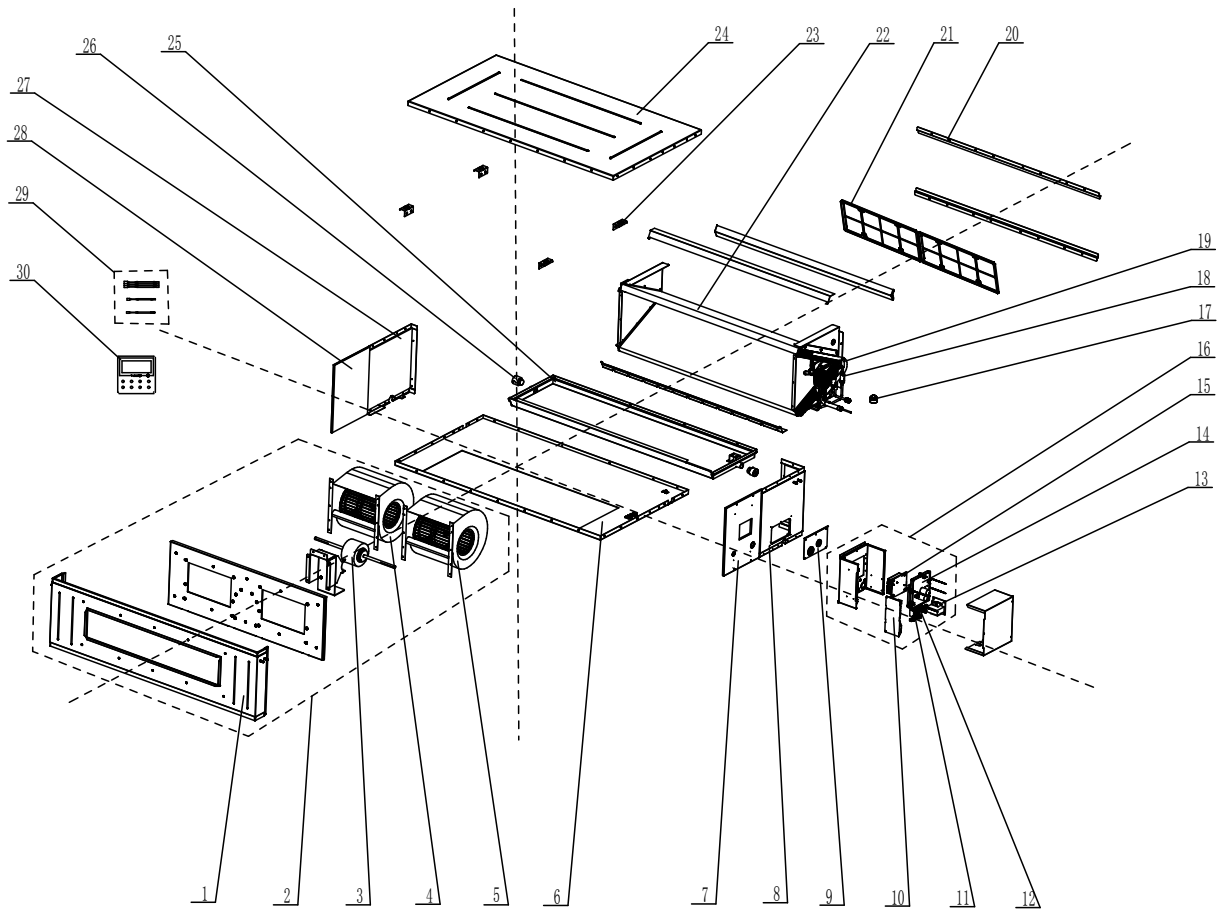

No.	Name of part	For the following unit		For the following unit	
		Unit	Product Code	Unit	Product Code
		GMV-ND224PH/A-T	CM800N3721	GMV-ND280PH/A-T	CM800N3731
		Part code	Quantity	Part code	Quantity
1	Front Side Plate Sub-Assy	01314627	1	01314315	1
2	Centrifugal fan assy	15404100051	1	15404100061	1
3	Brushless DC Motor	15704100009	1	15704100009	1
4	Motor	15705306	1	15704118	1
5	Motor	15705307	1	1570411801	1
6	Lower Cover Plate Sub-Assy	01265357	1	01264213	1
7	Right Side Plate Assy	01314321	1	01314312	1
8	Front Side Plate assy 2	01314627	1	01314315	1
9	Seal Of Connection Pipe sub-assy	01494709	1	01494709	1
10	Main Board	30226000064	1	30221000023	1
11	Terminal Board	4201800002601	1	4201800002601	1
12	Terminal Board	42010259	1	42010259	1
13	Reactor	43130189	1	43130189	1
14	Main Board	30221000018	1	30226000064	1
15	Radiator	49018000068	1	49018000068	1
16	Electric Box Assy	01394100450	1	01394100450	1
17	Electric Expand Valve Fitting	4304413205	1	4304413205	1

No.	Name of part	For the following unit		For the following unit	
		Unit	Product Code	Unit	Product Code
		GMV-ND224PH/A-T	CM800N3721	GMV-ND280PH/A-T	CM800N3731
		Part code	Quantity	Part code	Quantity
18	Strainer	0741410000601	1	0741410000601	1
19	Electronic Expansion Valve	07331139	1	07331139	1
20	filter guide groove	02284107	2	02284105	2
21	Filter Sub-Assy	11725211	2	11724102	2
22	Evaporator Assy	01024100119	1	01024100124	1
23	Hook	02112466	4	02112466	4
24	Top Cover Board Sub-assy	01265359	1	01264215	1
25	Water Tray Assy	01284620	1	01284306	1
26	Choke Plug of Water Pipe	76712454	2	76712454	2
27	Right Side Plate Sub-Assy	01314321	1	01314312	1
28	Right Side Plate Sub-Assy	01314100086'	1	01314100088	1
29	Sensor Sub-assy	39008000103G	1	39008000103G	1
30	Display Board	30296000040	1	30296000040	1

Above data is subject to change without notice, pls reference the SP in global service website.

5.3 Low Static Pressure Duct Type

Exploded View of GMV-ND22PLS/A-T, GMV-ND25PLS/A-T, GMV-ND28PLS/A-T,
GMV-ND32PLS/A-T, GMV-ND36PLS/A-T:

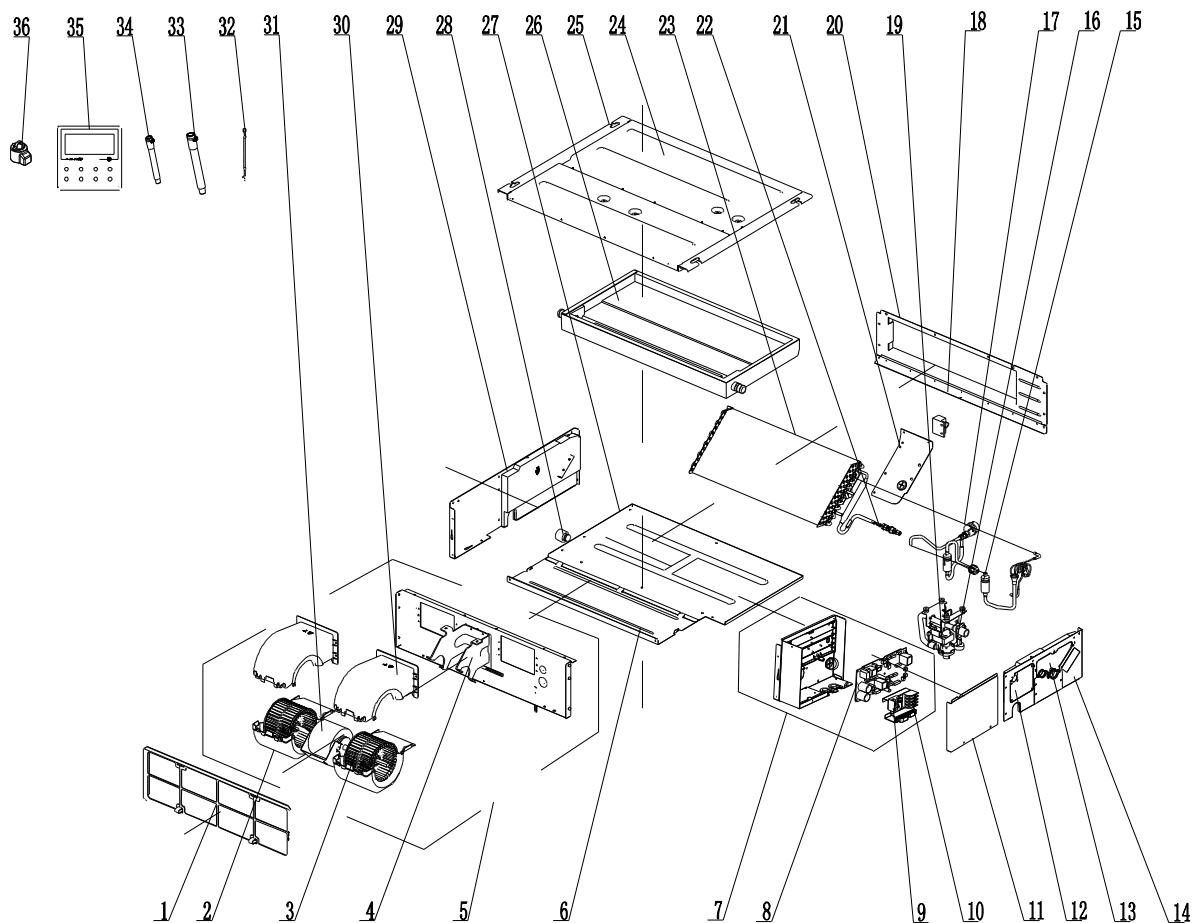

No.	Name of part	For the following unit		For the following unit	
		Unit	Product Code	Unit	Product Code
		GMV-ND22PLS/A-T	CM800N3370	GMV-ND32PLS/A-T	CM800N3390
		GMV-ND25PLS/A-T	CM800N3380	GMV-ND36PLS/A-T	CM800N3500
		GMV-ND28PLS/A-T	CM800N3490	/	/
		Part code	Quantity	Part code	Quantity
1	Filter Sub-Assy	11725209	1	11725209	1
2	Rear Volute Casing	26905206	2	26905206	2
3	Centrifugal Fan	10425200	2	10425200	2
4	Supporter	01804100140	1	01804100140	1
5	Blower Mounting Plate Sub-Assy	01324100038	1	01324100038	1
6	Cover Board (Fan Motor)	01265300	1	01265300	1
7	Electric Box Assy	01394100204	1	01394100204	1
8	Main Board	30226000029	1	30226000029	1
9	Terminal Board	42011106	1	42011106	1
10	Terminal Board	4201800002601	1	4201800002601	1
11	Electric Box Cover	01424100035	1	01424100035	1
12	Sealplate Sub-assy (drainage)	01495315	1	01495315	1
13	Sealplate Sub-assy (outlet)	01495316	1	01495316	1
14	Left Side Plate Assy	01315200087	1	01315200087	1
15	Filter	07213050	2	07213050	2
16	Water Level Switch	45020216	1	45020216	1
17	Electronic Expansion Valve	07334463	1	07334463	1
18	Cover of Air Outlet	01265298	1	01265298	1
19	Water Pump	43138000068	1	43138000068	1
20	Air Outlet Frame Assy	01374636	1	01374636	1
21	Sealplate Sub-Assy	01495317	1	01495317	1
22	Filter Sub-Assy	11128633	1	11128633	1
23	Evaporator Assy	01024100108	1	01024100109	1
24	Top Cover Board Assy	01265325	1	01265325	1
25	Supporter	01895225	2	01895225	2
26	Water Tray Assy	01285332	1	01285332	1
27	Bottom Cover Plate	01265299	1	01265299	1
28	Choke Plug of Drain Pipe	76815214	2	76815214	2
29	Right Side Plate Assy	01315335	1	01315335	1
30	Front Volute Casing	26905205	2	26905205	2
31	Fan Motor	15704100001	1	15704100001	1
32	Sensor Sub-Assy	39004168G	1	39004168G	1
33	Drain Hose Sub-Assy	05232050	1	05232050	1
34	Pump Drainpipe	200070000008	1	200070000008	1
35	Display Board	30296107	1	30296107	1
36	Electric Expand Valve Fitting	4304413215	1	4304413215	1

Above data is subject to change without notice, pls reference the SP in global service website.

Exploded View of GMV-ND40PLS/A-T, GMV-ND45PLS/A-T, GMV-ND50PLS/A-T:

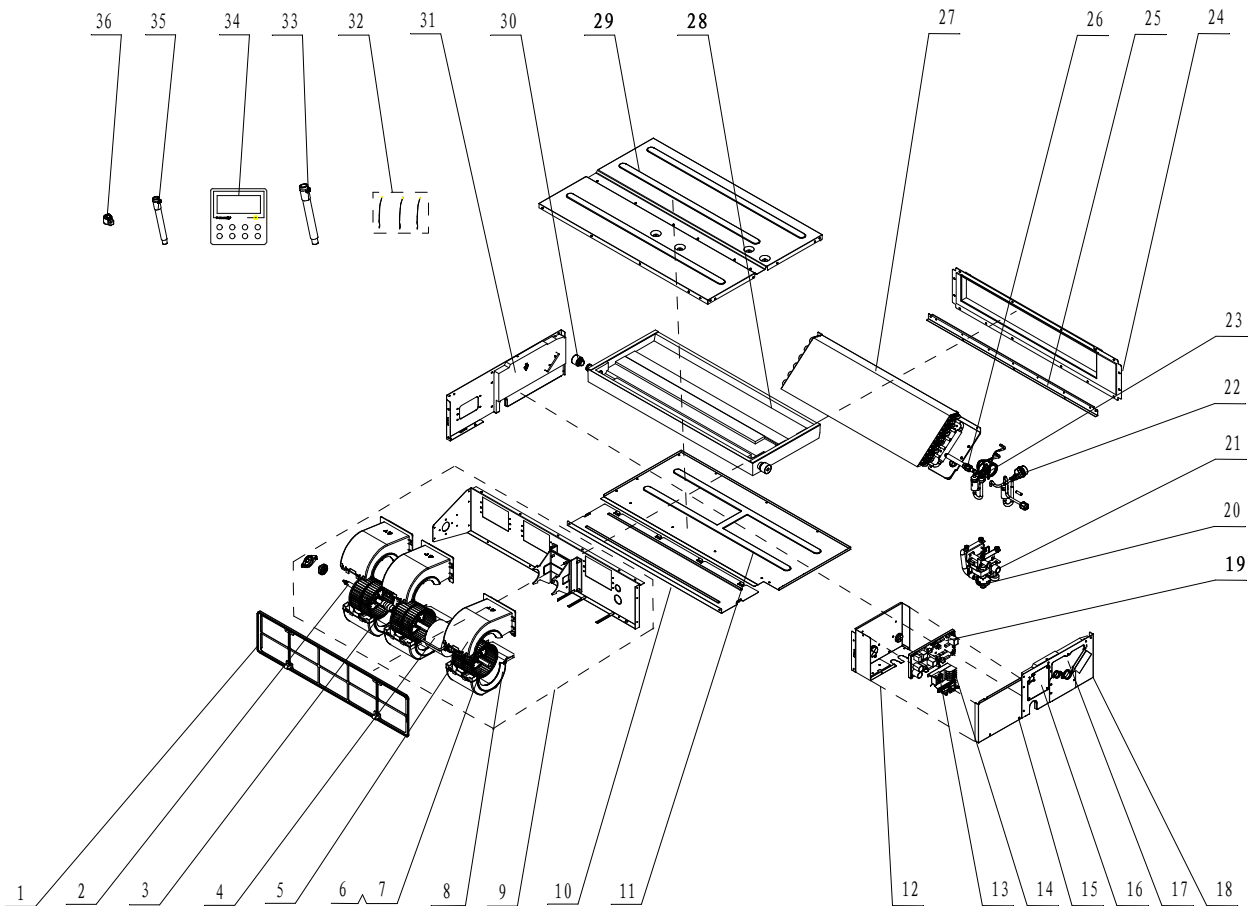

No.	Name of part	For the following unit	
		Unit	Product Code
		GMV-ND40PLS/A-T	CM800N3400
		GMV-ND45PLS/A-T	CM800N3410
		GMV-ND50PLS/A-T	CM800N3420
		Part code	Quantity
1	Filter Sub-Assy	11725210	1
2	Rotary Axis Sub-Assy	73018020	1
3	Joint Slack	73018731	1
4	Fan Motor	15704100001	1
5	Front Volute Casing	26905205	3
6	Centrifugal Fan	10425200	3
7	Fan Bearing	76512210	1
8	Rear Volute Casing	26905206	3
9	Centrifugal fan assy	15404100023	1
10	Cover board (Fan motor)	01265333	1
11	Bottom Cover Plate	01265332	1
12	Electric Box Assy	01394100204	1
13	Terminal Board	42011106	1
14	Terminal Board	4201800002601	1
15	Electric Box Cover	01424100035	1

No.	Name of part	For the following unit	
		Unit	Product Code
		GMV-ND40PLS/A-T	CM800N3400
		GMV-ND45PLS/A-T	CM800N3410
		GMV-ND50PLS/A-T	CM800N3420
	Part code	Quantity	
16	Sealplate sub-assy (drainage)	01495315	1
17	Sealplate sub-assy (outlet)	01495316	1
18	Left Side Plate Assy	01315200087	1
19	Main Board	30226000029	1
20	Water Pump	43138000068	1
21	Water Level Switch	45020216	1
22	Electronic Expansion Valve	07334466	1
23	Strainer	0741410000601	2
24	Air Outlet Frame Assy	01374637	1
25	Cover of Air Outlet	01265331	1
26	Filter Sub-Assy	11128633	1
27	Evaporator Assy	01024100110	1
28	Water Tray Assy	01285333	1
29	Top Cover Board Assy	01265328	1
30	Choke Plug of Drain Pipe	76815214	2
31	Right Side Plate Assy	01305263	1
32	Sensor Sub-assy	39004168G	1
33	Drain Hose Sub-Assy	05232050	1
34	Display Board	30296000040	1
35	Pump Drainpipe	200070000008	1
36	Electric Expand Valve Fitting	4304413215	1

Above data is subject to change without notice, pls reference the SP in global service website.

Exploded View of GMV-ND56PLS/A-T、GMV-ND63PLS/A-T:

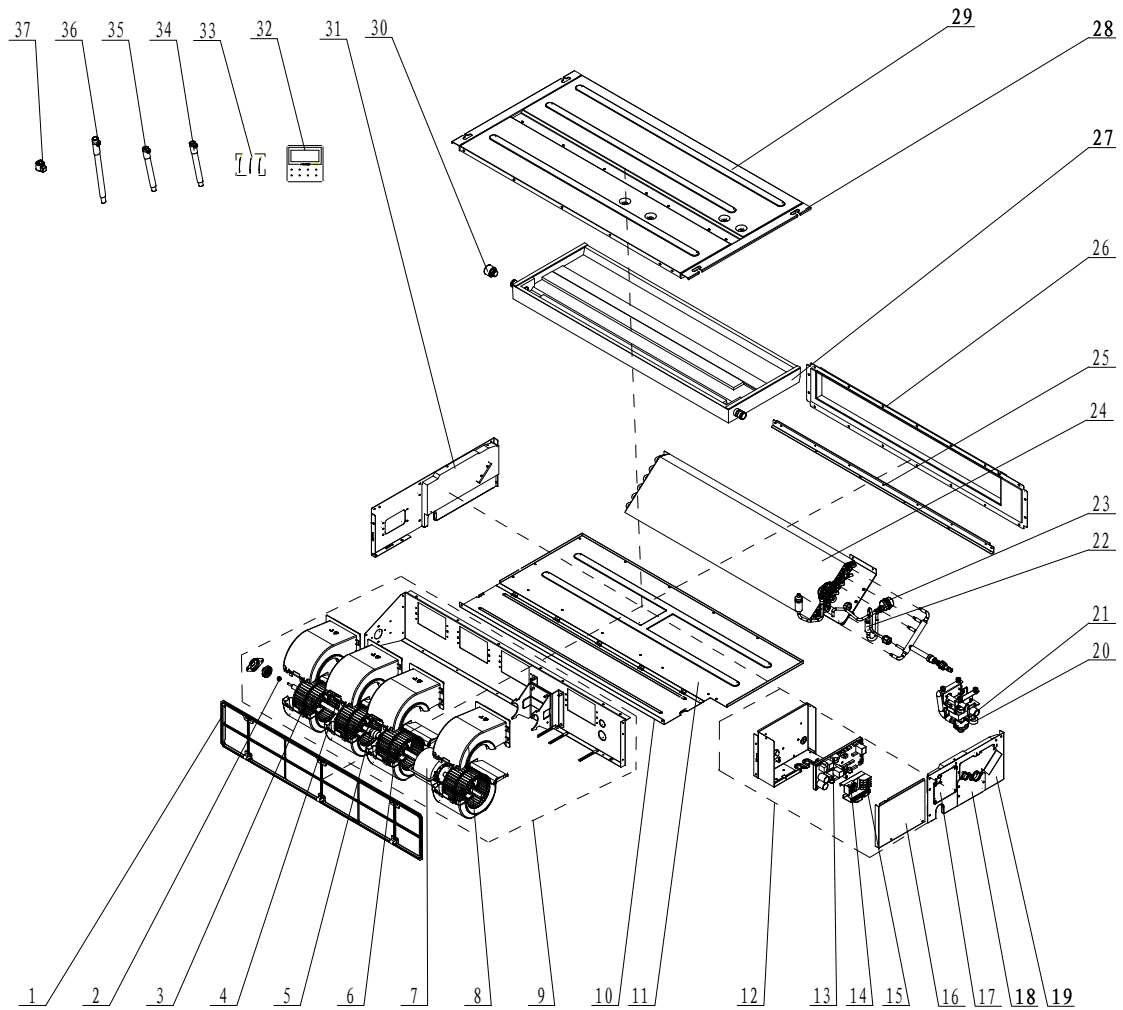

No.	Name of part	For the following unit		For the following unit	
		Unit	Product Code	Unit	Product Code
		GMV-ND56PLS/A-T	CM800N3510	GMV-ND63PLS/A-T	CM800N3430
		Part code	Quantity	Part code	Quantity
1	Filter Sub-Assy	11725208	1	11725208	1
2	Fan Bearing	76512210	1	76512210	1
3	Centrifugal Fan	10425200	3	10425200	3
4	Rotary Axis Sub-Assy	73018000029	1	73018000029	1
5	Joint Slack	73018731	1	73018731	1
6	Rear Volute Casing	26905206	3	26905206	3
7	Fan Motor	15704100001	1	15704100001	1
8	Front Volute Casing	26905205	3	26905205	3
9	Centrifugal fan assy	15404100024	1	15404100024	1
10	Cover board (Fan motor)	01265338	1	01265338	1
11	Bottom Cover Plate	01265337	1	01265337	1
12	Main Board	30226000029	1	30226000029	1
13	Terminal Board	42011106	1	42011106	1
14	Electric Box Assy	01394100204	1	01394100204	1
15	Terminal Board	4201800002601	1	4201800002601	1

No.	Name of part	For the following unit		For the following unit	
		Unit	Product Code	Unit	Product Code
		GMV-ND56PLS/A-T	CM800N3510	GMV-ND63PLS/A-T	CM800N3430
		Part code	Quantity	Part code	Quantity
16	Electric Box Cover	01424100035	1	01424100035	1
17	Sealplate sub-assy (drainage)	01495315	1	01495315	1
18	Sealplate sub-assy (outlet)	01495316	1	01495316	1
19	Left Side Plate Assy	01315200087	1	01315200087	1
20	Water Level Switch	45020216	1	45020216	1
21	Water Pump	43138000068	1	43138000068	1
22	Strainer	0741410000601	2	0741410000601	2
23	Electronic Expansion Valve	07334466	1	07334466	1
24	Evaporator Assy	01024100111	1	01024100111	1
25	Cover of Air Outlet	01265335	1	01265335	1
26	Air Outlet Frame Assy	01374635	1	01374635	1
27	Water Tray Assy	01285334	1	01285334	1
28	Supporter	01895225	2	01895225	2
29	Top Cover Board Assy	01265339	1	1265339	1
30	Choke Plug of Drain Pipe	76815214	2	76815214	2
31	Right Side Plate Assy	01305263	1	01305263	1
32	Display Board	30296000040	1	30296000040	1
33	Sensor Sub-assy	39004168G	1	9004168G	1
34	Drain Hose Sub-Assy	05232050	1	05232050	1
35	Pump Drainpipe	200070000008	1	200070000008	1
36	Corrugated Pipe	05015408	1	05015408	1
37	Electric Expand Valve Fitting	4304413215	1	4304413215	1

Above data is subject to change without notice, pls reference the SP in global service website.

Exploded View of GMV-ND71PLS/A-T, GMV-ND80PLS/A-T:

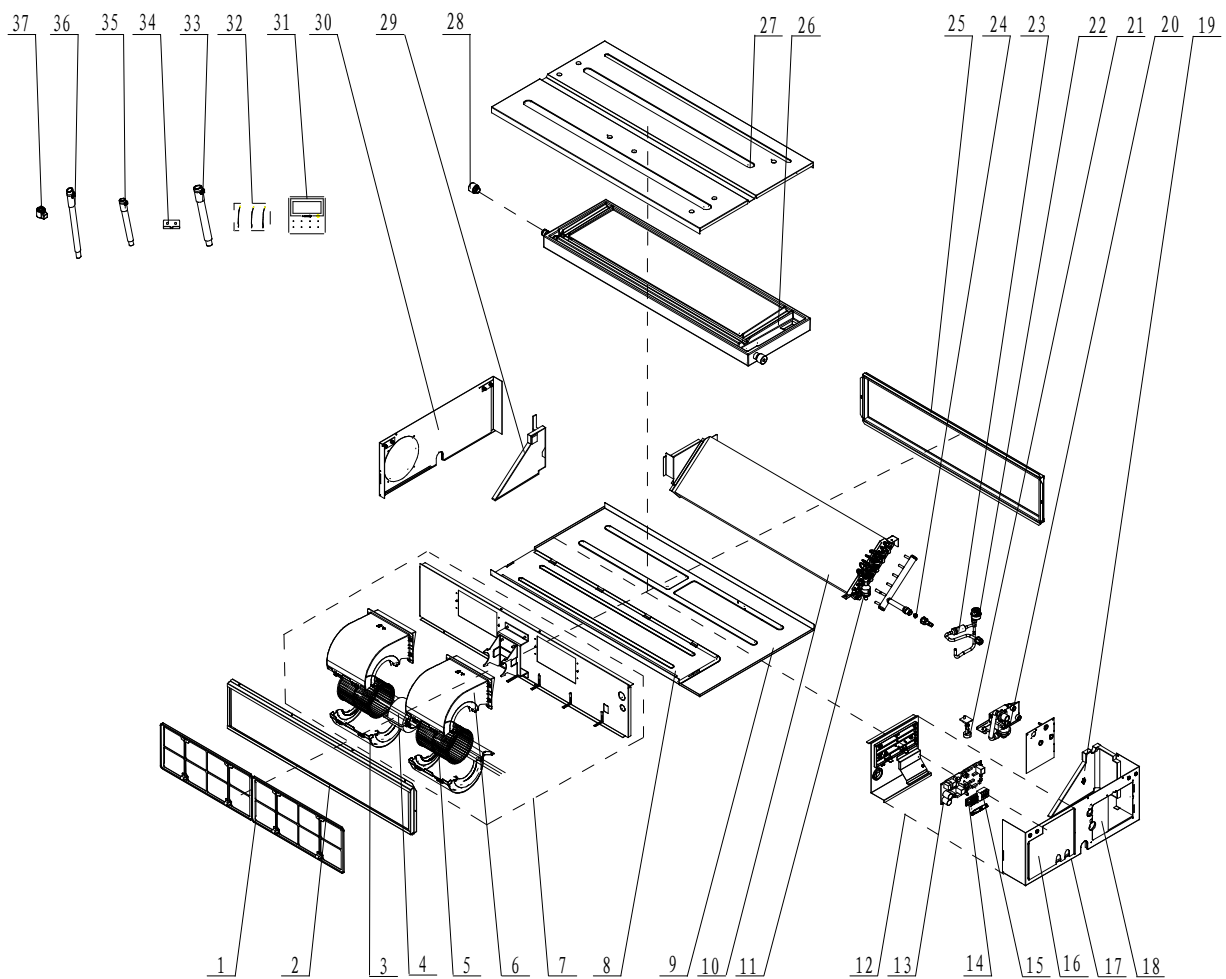

No.	Name of part	For the following unit	
		Unit	Product Code
		GMV-ND71PLS/A-T	CM800N3520
		GMV-ND80PLS/A-T	CM800N3440
		Part code	Quantity
1	Filter Sub-Assy	11725207	2
2	Air Intake Side Board Sub-assy	02225265	1
3	Rear volute casing	26905209	2
4	Fan Motor	15704100001	1
5	Centrifugal fan	1041410101	2
6	Front volute casing	26905208	2
7	Centrifugal fan assy	15404100014	1
8	Cover Of Air-In	01265346	1
9	Bottom Cover Plate	01265348	1
10	Evaporator Assy	01024100112	1
11	Filter	07415210	1
12	Electric Box Assy	01394100205	1
13	Main Board	30226000029	1
14	Terminal Board	4201800002601	1

No.	Name of part	For the following unit	
		Unit	Product Code
		GMV-ND71PLS/A-T	CM800N3520
		GMV-ND80PLS/A-T	CM800N3440
		Part code	Quantity
15	Terminal Board	42011106	1
16	Electric Box Cover	01425262	1
17	Left Side Plate Assy	01315299	1
18	Seal Of Connection Pipe sub-assy	01495238	1
19	Left Baffler Sub-Assy	12505217	1
20	Water Pump	4313822001	1
21	Water Level Switch	45020216	1
22	Electronic Expansion Valve	07334466	1
23	Strainer	0741410000601	1
24	Filter Sub-Assy	07210028	1
25	Air Outlet Side Board assy	02225264	1
26	Water Tray Assy	01285276	1
27	Top Cover Board Assy	01265350	1
28	Choke Plug of Drain Pipe	76815214	2
29	Right Baffler Sub-Assy	12505216	1
30	Right Side Plate Assy	1315298	1
31	Display Board	30296000040	1
32	Sensor Sub-assy	39004169G	1
33	Drain Hose Sub-Assy	05232050	1
34	Hook	02112466	4
35	Pump Drainpipe	04615487	1
36	Corrugated Pipe	05015408	1
37	Electric Expand Valve Fitting	4304413215	1

Above data is subject to change without notice, pls reference the SP in global service website.

Exploded View of GMV-ND90PLS/A-T, GMV-ND100PLS/A-T, GMV-ND112PLS/A-T, GMV-ND125PLS/A-T, GMV-ND140PLS/A-T:

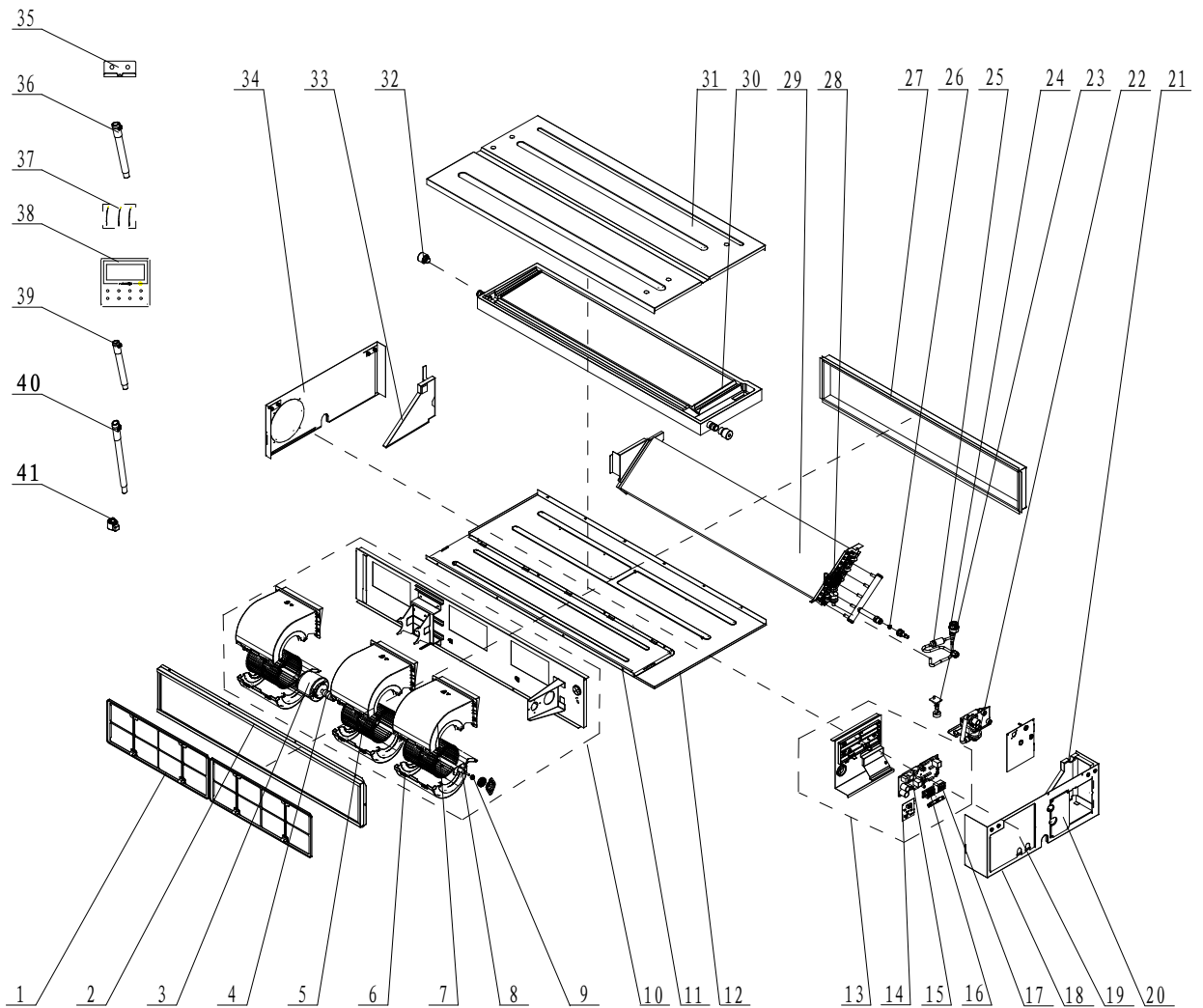

No.	Name of part	For the following unit		For the following unit	
		Unit	Product Code	Unit	Product Code
		GMV-ND90PLS/A-T	CM800N3450	GMV-ND125PLS/A-T	CM800N3480
		GMV-ND100PLS/A-T	CM800N3460	GMV-ND140PLS/A-T	CM800N3470
		GMV-ND112PLS/A-T	CM800N3530	-	-
		Part code	Quantity	Part code	Quantity
1	Filter Sub-Assy	11725206	2	11725206	2
2	Air intake side-board Sub-assy	02225271	1	02225271	1
3	Brushless DC Motor	15705200005	1	15705200005	1
4	Joint Slack	73018731	1	73018731	1
5	Centrifugal fan	1041410101	3	1041410101	3
6	Rear volute casing	26905209	3	26905209	3
7	Front volute casing	26905208	3	26905208	3
8	Rotary Axis Sub-Assy	73018000030	1	73018000030	1
9	Fan Bearing	76512210	1	76512210	1
10	Centrifugal fan assy	15404100015	1	15404100015	1
11	Cover Of Air-In	01265344	1	01265344	1

No.	Name of part	For the following unit		For the following unit	
		Unit	Product Code	Unit	Product Code
		GMV-ND90PLS/A-T	CM800N3450	GMV-ND125PLS/A-T	CM800N3480
		GMV-ND100PLS/A-T	CM800N3460	GMV-ND140PLS/A-T	CM800N3470
		GMV-ND112PLS/A-T	CM800N3530	-	-
		Part code	Quantity	Part code	Quantity
12	Bottom Cover Plate	01265343	1	01265343	1
13	Electric Box Assy	01394100242	1	01394100242	1
14	Filter Board	30226000051	2	30226000051	2
15	Main Board	30226000030	1	30226000030	1
16	Terminal Board	42011106	1	42011106	1
17	Terminal Board	4201800002601	1	4201800002601	1
18	Right Side Plate Assy	01314100055	1	01314100055	1
19	Electric Box Cover	01425262	1	01425262	1
20	Seal Of Connection Pipe sub-assy	01495238	1	01495238	1
21	Left Baffler Sub-Assy	12505217	1	12505217	1
22	Water Pump	4313822001	1	4313822001	1
23	Water Level Switch	5020216	1	45020216	1
24	Electronic Expansion Valve	07334468	1	07334468	1
25	Strainer	0741410000601	1	0741410000601	1
26	Filter Sub-Assy	07210028	1	07210028	1
27	Border Plate of Air outlet Sub-Assy	02225270	1	02225270	1
28	Filter	07415210	1	07415210	1
29	Evaporator Assy	01024100106	1	01024100107	1
30	Water Tray Assy	01285275	1	01285275	1
31	Top Cover Board Assy	0126534901	1	0126534901	1
32	Choke Plug of Drain Pipe	76815214	2	76815214	2
33	Right Baffler Sub-Assy	12505216	1	12505216	1
34	Left Side Plate Assy	01315299	1	01315299	1
35	Hook	02112466	4	02112466	4
36	Drain Hose Sub-Assy	05232050	1	05232050	1
37	Sensor Sub-assy	39004169G	1	39004169G	1
38	Display Board	30296000040	1	30296000040	1
39	Pump Drainpipe	04615487	1	04615487	1
40	Corrugated Pipe	05015408	1	05015408	1
41	Electric Expand Valve Fitting	4304413215	1	4304413215	1

Above data is subject to change without notice, pls reference the SP in global service website.

Exploded View of GMV-ND18PLS/C-T、GMV-ND22PLS/C-T、GMV-ND25PLS/C-T、
GMV-ND28PLS/C-T:

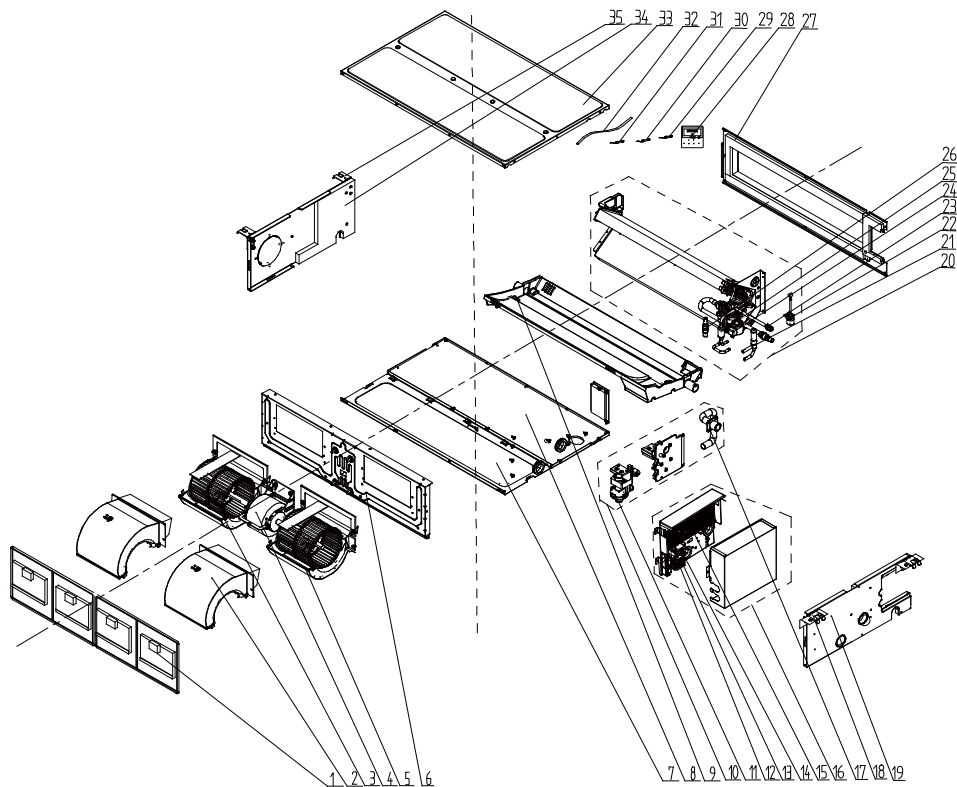

No.	Name of part	For the following unit		
		Unit	Product Code	
			GMV-ND18PLS/C-T	CM810N2030
			GMV-ND22PLS/C-T	CM810N1800
			GMV-ND25PLS/C-T	CM810N1810
	GMV-ND28PLS/C-T	CM810N1770		
1	Top Cover Board Assy	01265200066	1	
2	Blower Mounting Plate Sub-Assy	01325200034	1	
3	Brushless DC Motor	150104060010	1	
4	Centrifugal Fan	10425200003	2	
5	Propeller Housing(Upper)	26905200018	2	
6	Propeller Housing(Lower)	26905200019	2	
7	Right Side Plate Assy	01315200053	1	
8	Right Side Plate Sub-Assy	01315200052	1	
9	Left Side Plate Assy	000080000009	1	
10	Cable Cross Loop	76515202	2	
11	Evaporator Assy	01024100207	1	
12	Evaporator Assy	01025200185	1	
13	Temp Sensor Sleeving	05212423	1	
14	Electronic Expansion Valve	07334463	1	
15	Pipe Connector	06640003	1	
16	Sealing Cap(Pressure Warning)	26112192	1	
17	Strainer	07213050	1	
18	Temp Sensor Sleeving	05212423	1	
19	Strainer	0721200102	1	
20	Cable Cross Loop	76510021	1	
21	Electric Expand Valve Fitting	4304413253	1	
22	Liquid Level Switch	430024000005	1	
23	Sensor Insert	42020063	2	

No.	Name of part	For the following unit	
		Unit	Product Code
		GMV-ND18PLS/C-T	CM810N2030
		GMV-ND22PLS/C-T	CM810N1800
		GMV-ND25PLS/C-T	CM810N1810
		GMV-ND28PLS/C-T	CM810N1770
24	Temperature Sensor	3900005910	1
25	Temperature Sensor	390000595	1
26	Water Pump Assy	000104060009	1
27	Water Pump	812007060016	1
28	Drainage Pipe(Rubber)	760022000001	1
29	Water Tray Assy	01285200020	1
30	Rubber Plug	76815200002	2
31	Bottom Cover Plate Assy	01264100102	1
32	Air Outlet Frame Assy	01374100057	1
33	Cover Plate(Air return)	01265200057	1
34	Filter Sub-Assy	111001000082	2
35	Hook	02112446	2
36	Bolt	70210051	4
37	Hook 2	01344100034	2
38	Bolt	70210051	2
39	Electric Box Assy	100002063081	1
40	Main Board	300002060289	1
41	XY capacitor	33030013	2
42	Fuse	46010055	1
43	Main Board	300002060297	1
44	Terminal Board	42200006000401	1
45	Terminal Board	42011106	1
46	Cable Cross Loop	76515202	2
47	Jumper	4202021903	1
48	Pass Wire Ring Sub-assy	76614102	2
49	Temperature Sensor	390000456	1
50	Drain Hose Sub-Assy	05232050	1
51	Nut with Washer	70310014	4
52	Display Board	30296000040	1
53	Keyboard	300031000004	1
54	Temperature Sensor	3900800014701	1

Above data is subject to change without notice, pls reference the SP in global service website.

Exploded View of GMV-ND32PLS/C-T、GMV-ND36PLS/C-T:

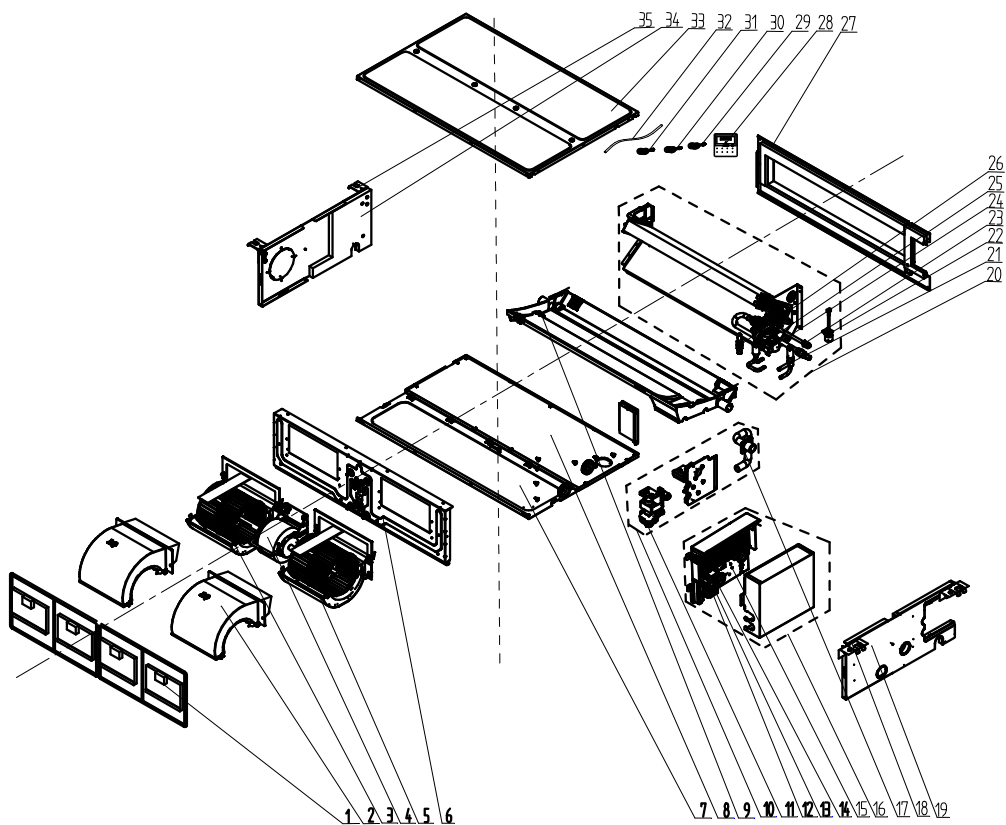

No.	Name of part	For the following unit	
		Unit	Product Code
		GMV-ND32PLS/C-T	CM810N1820
		GMV-ND36PLS/C-T	CM810N1760
1	Top Cover Board Assy	01265200066	1
2	Blower Mounting Plate Sub-Assy	01325200034	1
3	Brushless DC Motor	150104060010	1
4	Centrifugal Fan	10425200003	2
5	Propeller Housing(Upper)	26905200018	2
6	Propeller Housing(Lower)	26905200019	2
7	Right Side Plate Assy	01315200053	1
8	Right Side Plate Sub-Assy	01315200052	1
9	Left Side Plate Assy	000080000009	1
10	Cable Cross Loop	76515202	2
11	Evaporator Assy	011001000062	1
12	Evaporator Assy	01024100192	1
13	Temp Sensor Sleeveing	05212423	1
14	Electronic Expansion Valve	07334463	1
15	Pipe Connector	06640003	1
16	Sealing Cap(Pressure Warning)	26112192	1
17	Strainer	07213050	1
18	Strainer	0721200102	1
19	Temp Sensor Sleeveing	05212423	1
20	Cable Cross Loop	76510021	1
21	Electric Expand Valve Fitting	4304413253	1
22	Liquid Level Switch	430024000005	1
23	Sensor Insert	42020063	2
24	Temperature Sensor	3900005910	1

No.	Name of part	For the following unit	
		Unit	Product Code
		GMV-ND32PLS/C-T	CM810N1820
		GMV-ND36PLS/C-T	CM810N1760
25	Temperature Sensor	390000595	1
26	Water Pump Assy	000104060009	1
27	Water Pump	812007060016	1
28	Drainage Pipe(Rubber)	760022000001	1
29	Water Tray Assy	01285200020	1
30	Rubber Plug	76815200002	2
31	Bottom Cover Plate Assy	01264100102	1
32	Air Outlet Frame Assy	01374100057	1
33	Cover Plate(Air return)	01265200057	1
34	Filter Sub-Assy	111001000082	2
35	Hook	02112446	2
36	Bolt	70210051	4
37	Hook 2	01344100034	2
38	Bolt	70210051	2
39	Electric Box Assy	100002063081	1
40	Main Board	300002060289	1
41	XY capacitor	33030013	2
42	Fuse	46010055	1
43	Main Board	300002060297	1
44	Terminal Board	42200006000401	1
45	Terminal Board	42011106	1
46	Cable Cross Loop	76515202	2
47	Jumper	4202021905	1
48	Pass Wire Ring Sub-assy	76614102	2
49	Temperature Sensor	390000456	1
50	Pipe Connection Nut ("J" shape)	06320006	1
51	Drain Hose Sub-Assy	05232050	1
52	Nut with Washer	70310014	4
53	Display Board	30296000040	1
54	Keyboard	300031000004	1
55	Temperature Sensor	3900800014701	1

Above data is subject to change without notice, pls reference the SP in global service website.

Exploded View of GMV-ND40PLS/C-T、GMV-ND45PLS/C-T:

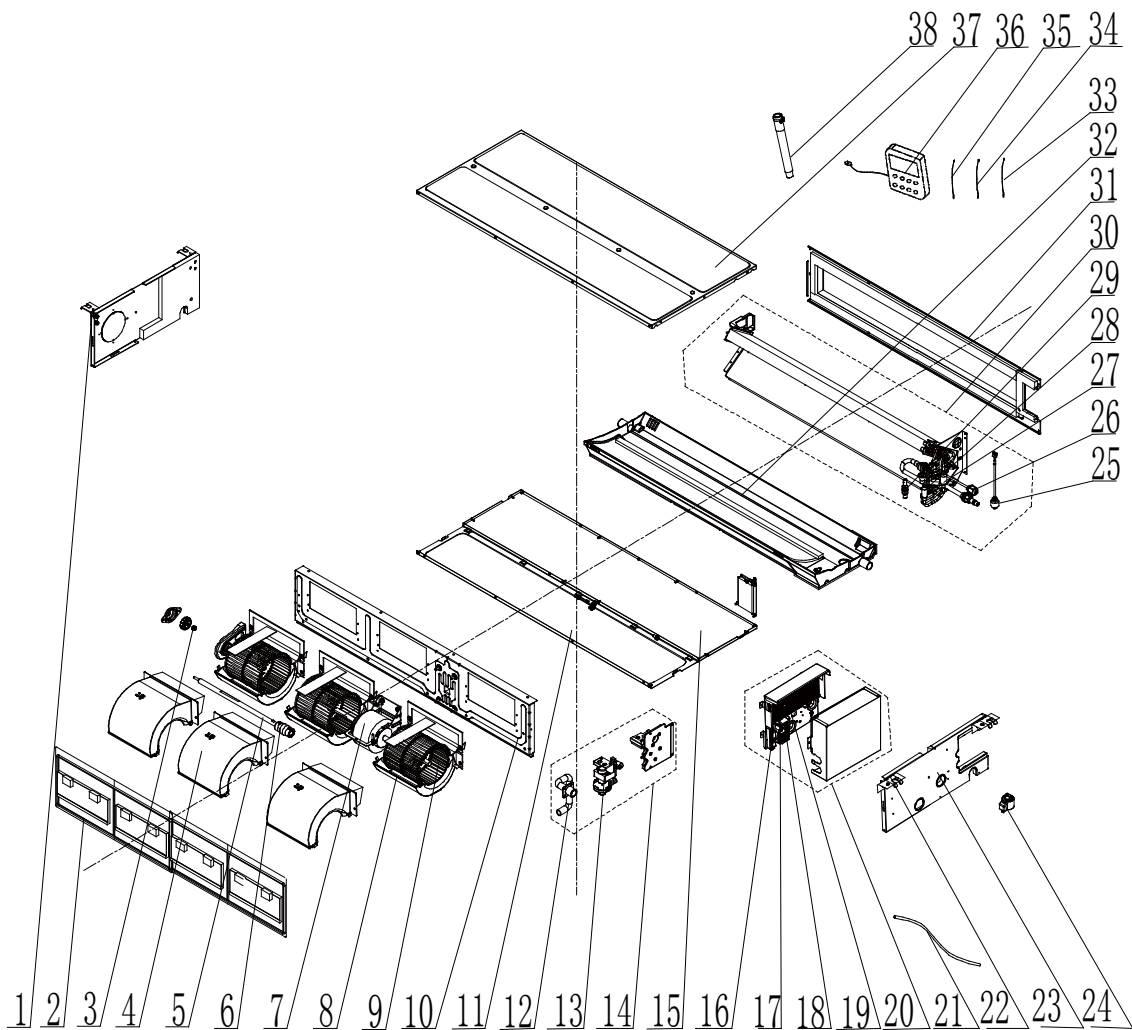

No.	Name of part	For the following unit	
		Unit	Product Code
		GMV-ND40PLS/C-T	CM810N1830
		GMV-ND45PLS/C-T	CM810N1740
1	Top Cover Board Assy	01265200068	1
2	Top Cover Board Sub-assy	01265200069	1
3	Blower Mounting Plate Sub-Assy	01325200035	1
4	Brushless DC Motor	150104060010	1
5	Centrifugal Fan	10425200003	3
6	Propeller Housing(Upper)	26905200018	3
7	Propeller Housing(Lower)	26905200019	3
8	Joint Slack	73018731	1
9	Rotary Axis Sub-Assy	73018761	1
10	Bearing Holder Sub-assy	26151139	1
11	Bearing Holder	26151138	1
12	Fan Bearing	76512210	1
13	Support Of Motor Bearing	02285200001	1
14	Support (shaft)	01805200175	1
15	Right Side Plate Assy	01315200053	1
16	Right Side Plate Sub-Assy	01315200052	1
17	Left Side Plate Assy	000080000009	1
18	Cable Cross Loop	76515202	2
19	Evaporator Assy	01024100209	1
20	Evaporator Assy	01024100193	1

No.	Name of part	For the following unit	
		Unit	Product Code
		GMV-ND40PLS/C-T	CM810N1830
		GMV-ND45PLS/C-T	CM810N1740
21	Temp Sensor Sleeving	05212423	1
22	Electronic Expansion Valve	07334466	1
23	Pipe Connector	06640003	1
24	Sealing Cap(Pressure Warning)	26112192	1
25	Strainer	07213050	1
26	Temp Sensor Sleeving	05212423	1
27	Strainer	0721200102	1
28	Cable Cross Loop	76510021	1
29	Airproof Sealant	76012015	1
30	Electric Expand Valve Fitting	4304413253	1
31	Liquid Level Switch	430024000005	1
32	Sensor Insert	42020063	2
33	Temperature Sensor	3900005910	1
34	Temperature Sensor	000104060009	1
35	Water Pump Assy	000104060009	1
36	Water Pump	812007060016	1
37	Drainage Pipe(Rubber)	760022000001	1
38	Water Tray Assy	01285200022	1
39	Rubber Plug	76815200002	2
40	Bottom Cover Plate Assy	01264100103	1
41	Bottom Cover Plate	01265200072	1
42	Air Outlet Frame Assy	01374100058	1
43	Air Outlet Frame Sub-assy	01374100055	1
44	Cover Plate Sub-Assy	011657000032	1
45	Cover Of Air-In	01265200073	1
46	Filter Sub-Assy	111253038	2
47	Hook	02112446	2
48	Bolt	70210051	4
49	Hook 2	01344100034	2
50	Bolt	70210051	2
51	Electric Box Assy	100002063081	1
52	Main Board	300002060289	1
53	XY capacitor	33030013	2
54	Fuse	46010055	1
55	Main Board	300002060297	1
56	Terminal Board	42200006000401	1
57	Terminal Board	42011106	1
58	Cable Cross Loop	76515202	2
59	Jumper	4202021907	1
60	Pass Wire Ring Sub-assy	76614102	2
61	Temperature Sensor	390000456	1
62	Pipe Connection Nut ("J" shape)	06320006	1
63	Drain Hose Sub-Assy	05232050	1
64	Nut with Washer	70310014	4
65	Display Board	30296000040	1
66	Keyboard	300031000004	1
67	Temperature Sensor	3900800014701	1

Above data is subject to change without notice, pls reference the SP in global service website.

Exploded View of GMV-ND50PLS/C-T、GMV-ND56PLS/C-T、GMV-ND63PLS/C-T:

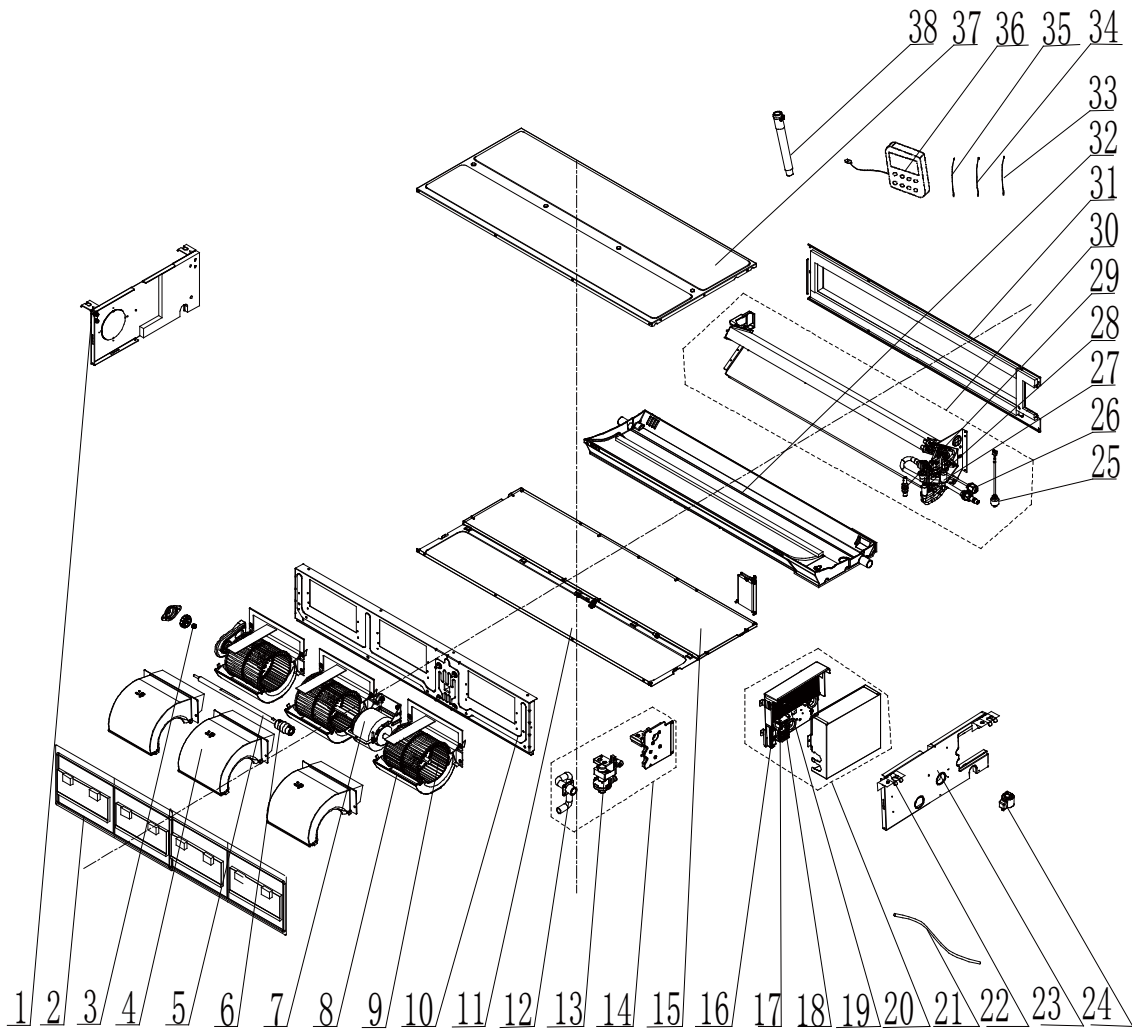

No.	Name of part	For the following unit	
		Unit	Product Code
		GMV-ND50PLS/C-T	CM810N1840
		GMV-ND56PLS/C-T	CM810N1850
		GMV-ND63PLS/C-T	CM810N1730
1	Top Cover Board Assy	01265200068	1
2	Top Cover Board Sub-assy	01265200069	1
3	Blower Mounting Plate Sub-Assy	01325200035	1
4	Brushless DC Motor	150104060009	1
5	Centrifugal Fan	10425200003	3
6	Propeller Housing(Upper)	26905200018	3
7	Propeller Housing(Lower)	26905200019	3
8	Joint Slack	73018731	1
9	Rotary Axis Sub-Assy	73018761	1
10	Bearing Holder Sub-assy	26151139	1
11	Bearing Holder	26151138	1
12	Fan Bearing	76512210	1
13	Support Of Motor Bearing	02285200001	1
14	Support (shaft)	01805200175	1
15	Right Side Plate Assy	01315200053	1
16	Right Side Plate Sub-Assy	01315200052	1
17	Left Side Plate Assy	000080000009	1
18	Cable Cross Loop	76515202	2

No.	Name of part	For the following unit	
		Unit	Product Code
		GMV-ND50PLS/C-T	CM810N1840
		GMV-ND56PLS/C-T	CM810N1850
		GMV-ND63PLS/C-T	CM810N1730
19	Evaporator Assy	011001000063	1
20	Evaporator Assy	01024100194	1
21	Temp Sensor Sleeving	05212423	1
22	Electronic Expansion Valve	07334466	1
23	Sealing Cap(Pressure Warning)	2611219201	1
24	Strainer	07213050	1
25	Strainer	0721200102	1
26	Capillary tube	81020167	1
27	Temp Sensor Sleeving	05212423	1
28	Cable Cross Loop	76510021	1
29	Airproof Sealant	76012015	1
30	Electric Expand Valve Fitting	4304413253	1
31	Liquid Level Switch	430024000005	1
32	Sensor Insert	42020063	2
33	Temperature Sensor	3900005910	1
34	Temperature Sensor	390000595	1
35	Water Pump Assy	000104060009	1
36	Water Pump	812007060016	1
37	Drainage Pipe(Rubber)	760022000001	1
38	Water Tray Assy	01285200022	1
39	Rubber Plug	76815200002	2
40	Bottom Cover Plate Assy	01264100103	1
41	Bottom Cover Plate	01265200072	1
42	Air Outlet Frame Assy	01374100058	1
43	Air Outlet Frame Sub-assy	01374100055	1
44	Cover Plate Sub-Assy	011657000032	1
45	Cover Of Air-In	01265200073	1
46	Filter Sub-Assy	111253038	2
47	Hook	02112446	2
48	Bolt	70210051	4
49	Hook 2	01344100034	2
50	Bolt	70210051	2
51	Electric Box Assy	100002063082	1
52	Main Board	300002060289	1
53	XY capacitor	33030013	2
54	Fuse	46010055	1
55	Main Board	300002060299	1
56	Cable Cross Loop	76515202	2
57	Terminal Board	42200006000401	1
58	Terminal Board	42011106	1
59	Pass Wire Ring Sub-assy	76614102	2
60	Temperature Sensor	390000456	1
61	Drain Hose Sub-Assy	05232050	1
62	Nut with Washer	70310014	4
63	Display Board	30296000040	1
64	Keyboard	300031000004	1
65	Temperature Sensor	3900800014701	1
66	Corrugated Pipe	05015408	1

Above data is subject to change without notice, pls reference the SP in global service website.

Exploded View of GMV-ND71PLS/C-T:

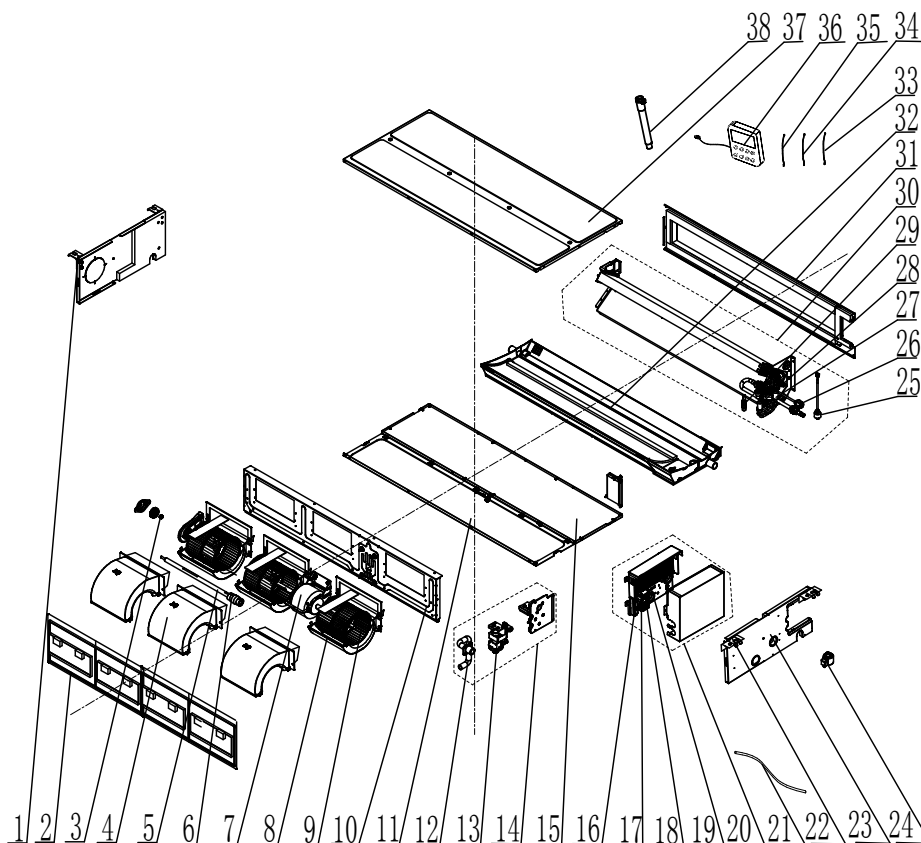

No.	Name of part	For the following unit	
		Unit	Product Code
		GMV-ND71PLS/C-T	CM810N1750
1	Top Cover Board Assy	0126520009201	1
2	Blower Mounting Plate Sub-Assy	01325200053	1
3	Brushless DC Motor	150104060011	1
4	Centrifugal Fan	10425200003	4
5	Propeller Housing(Upper)	26905200018	4
6	Propeller Housing(Lower)	26905200019	4
7	Joint Slack	73018731	2
8	Rotary Axis Sub-Assy	73018761	2
9	Bearing Holder Sub-assy	26151139	2
10	Bearing Holder	26151138	1
11	Fan Bearing	76512210	1
12	Support Of Motor Bearing	02285200001	2
13	Support (shaft)	01805200175	2
14	Right Side Plate Assy	01315200053	1
15	Right Side Plate Sub-Assy	01315200052	1
16	Left Side Plate Assy	000080000009	1
17	Cable Cross Loop	76515202	2
18	Evaporator Assy	01024100210	1
19	Evaporator Assy	01024100195	1
20	Temp Sensor Sleeving	05212423	1
21	Electronic Expansion Valve	07334466	1
22	Sealing Cap(Pressure Warning)	2611219201	1
23	Strainer	07213050	1
24	Strainer	0721200102	1
25	Capillary tube	81020167	1
26	Temp Sensor Sleeving	05212423	1

No.	Name of part	For the following unit	
		Unit	Product Code
		GMV-ND71PLS/C-T	CM810N1750
27	Cable Cross Loop	76510021	1
28	Electric Expand Valve Fitting	4304413253	1
29	Liquid Level Switch	430024000005	1
30	Sensor Insert	42020063	2
31	Temperature Sensor	3900005910	1
32	Temperature Sensor	390000595	1
33	Water Pump Assy	000104060009	1
34	Water Pump	812007060016	1
35	Drainage Pipe(Rubber)	760022000001	1
36	Water Tray Assy	01285200029	1
37	Rubber Plug	76815200002	2
38	Bottom Cover Plate Assy	01264100104	1
39	Air Outlet Frame Assy	01374100059	1
40	Cover Plate Sub-Assy	011657060049	1
41	Cover Of Air-In	01265200085	1
42	Filter Sub-Assy	111253039	2
43	Hook	02112446	2
44	Bolt	70210051	4
45	Hook 2	01344100034	2
46	Bolt	70210051	2
47	Electric Box Assy	100002063083	1
48	Main Board	300002060289	1
49	XY capacitor	33030013	2
50	Fuse	46010055	1
51	Main Board	300002060300	1
52	Terminal Board	42200006000401	1
53	Terminal Board	42011106	1
54	Cable Cross Loop	76515202	2
55	Jumper	4202021911	1
56	Temperature Sensor	390000456	1
57	Pass Wire Ring Sub-assy	76614102	2
58	Drain Hose Sub-Assy	05232050	1
59	Nut with Washer	70310014	4
60	Display Board	30296000040	1
61	Keyboard	300031000004	1
62	Temperature Sensor	3900800014701	1
63	Corrugated Pipe	05015408	1

Above data is subject to change without notice, pls reference the SP in global service website.

Exploded View of GMV-ND80PLS/C-T:

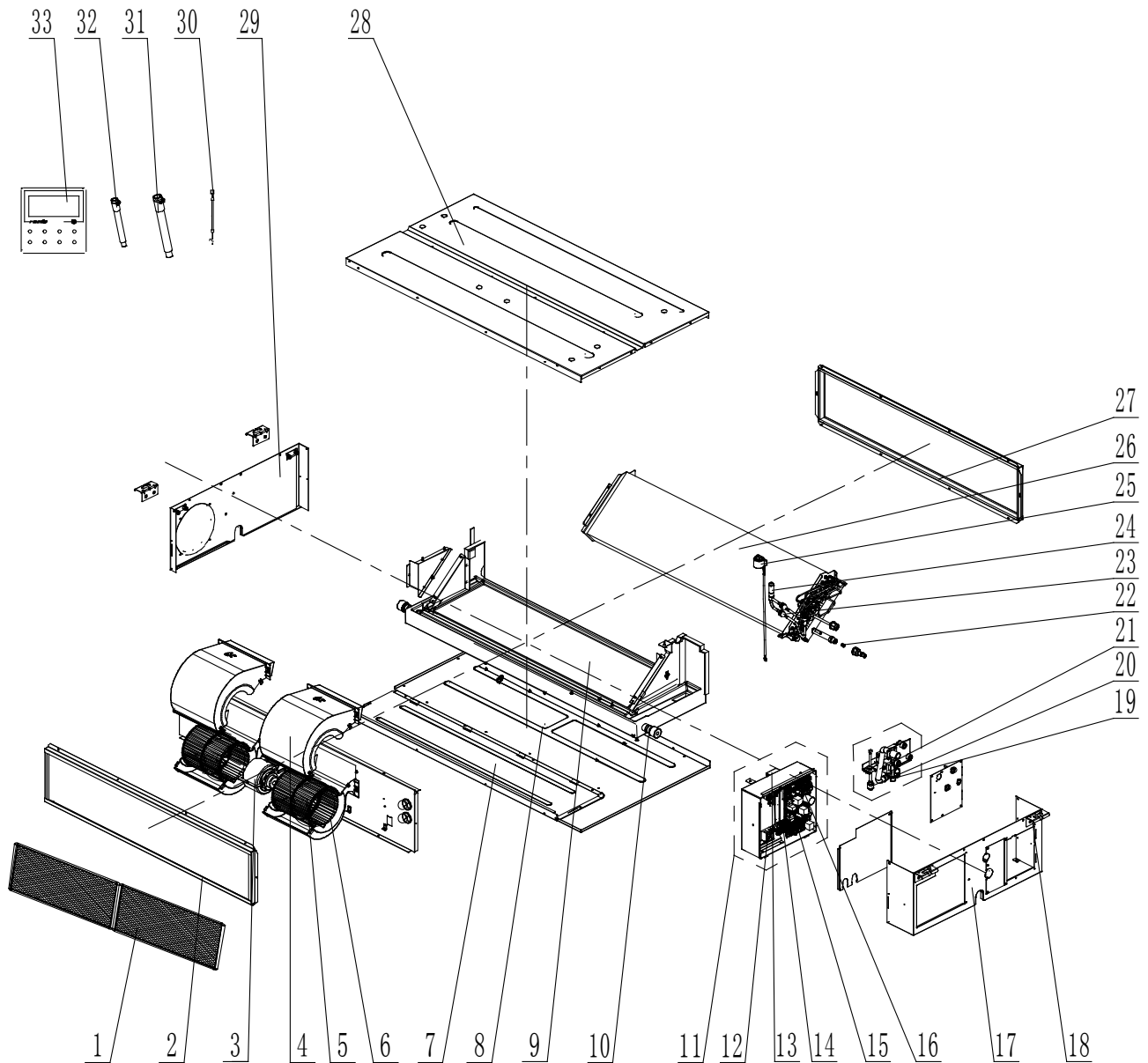

No.	Name of part	For the following unit	
		Unit	Product Code
		GMV-ND80PLS/C-T	CM810N1920
		Part code	Quantity
1	Filter Sub-Assy	'11725207	2
2	Air Intake Side Board Sub-Assy	'02225265	1
3	Brushless DC Motor	'150104060011	1
4	Volute Casing	'200230060003	2
5	Centrifugal Fan	'103003060003	2
6	Volute Casing	'200230060004	2
7	Cover Of Air-In	'01265346	1
8	Bottom Cover Plate	'01265348	1
9	Water Tray Assy	'01285276	1
10	Choke Plug of Drain Pipe	'76815214	
11	Electric Box Assy	'100002064927	1

No.	Name of part	For the following unit	
		Unit	Product Code
		GMV-ND80PLS/C-T	CM810N1920
		Part code	Quantity
12	Terminal Board	'42011106	1
13	Radiator	430034060043	
14	Terminal Board	'42200006000401	1
15	Main Board	300002060289	1
16	Main Board	300002060499	1
17	Right Side Plate Assy	'01315298	1
18	Hook	'02112466	4
19	Water Pump	'4313822001	1
20	Water Level Switch	'43002400000502	1
21	Pump Drainpipe	'04615487	1
22	Filter Sub-Assy	'07210028	
23	Strainer	'0721304401	1
24	Electronic Expansion Valve	'07334466	1
25	Electric Expand Valve Fitting	'4304413215	1
26	Evaporator Assy	'011001060429	1
27	Air Outlet Side Board Assy	'02225264	1
28	Top Cover Board Assy	'01265350	1
29	Left Side Plate Assy	'01315299	1
30	Sensor Sub-Assy	'39004169G	1
31	Drain Hose Sub-Assy	'05232050	1
32	Corrugated Pipe	'05015408	1
33	Display Board	'30296000040	1

Above data is subject to change without notice, pls reference the SP in global service website.

Exploded View of GMV-ND90PLS/C-T, GMV-ND100PLS/C-T, GMV-ND112PLS/C-T, GMV-ND125PLS/C-T, GMV-ND140PLS/C-T:

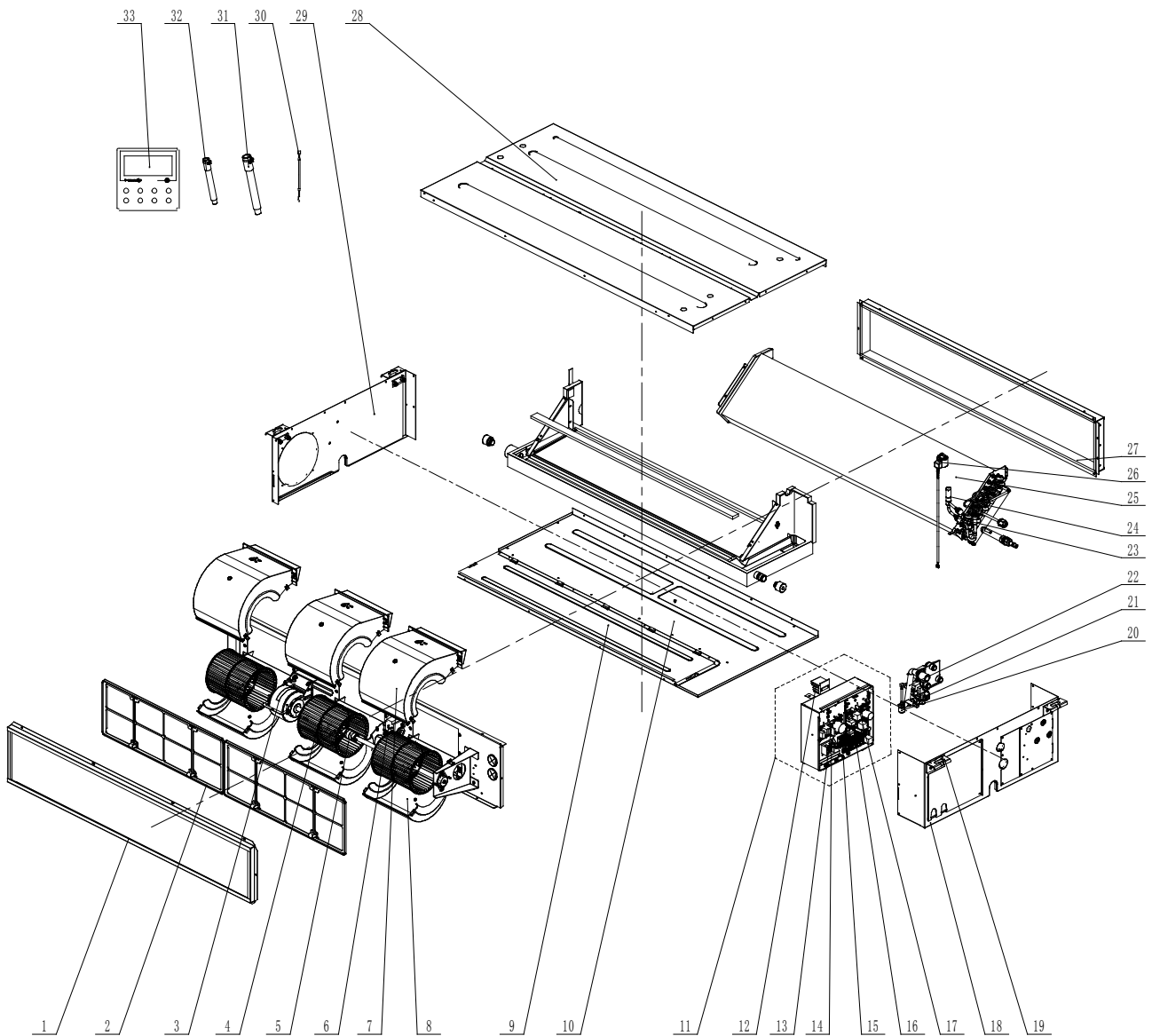

No.	Name of part	For the following unit		For the following unit	
		Unit	Product Code	Unit	Product Code
		GMV-ND90PLS/C-T	CM810N1960	GMV-ND125PLS/C-T	CM810N1940
		GMV-ND100PLS/C-T	CM810N1970	GMV-ND140PLS/C-T	CM810N1930
		GMV-ND112PLS/C-T	CM810N1950	-	-
		Part code	Quantity	Part code	Quantity
1	Filter Sub-Assy	11725206	2	11725206	2
2	Air Intake Side Board Sub-Assy	02225261	1	02225261	1
3	Brushless DC Motor	150104060015	1	150104060015	1
4	Centrifugal Fan	103003060003	3	103003060003	3
5	Joint Slack	73018731	1	73018731	1
6	Inductance	4312800001403	1	4312800001403	1
7	Volute Casing	200230060004	3	200230060004	3
8	Volute Casing	200230060003	3	200230060003	3
9	Cover Of Air-In	01265344	1	01265344	1

No.	Name of part	For the following unit		For the following unit	
		Unit	Product Code	Unit	Product Code
		GMV-ND90PLS/C-T	CM810N1960	GMV-ND125PLS/C-T	CM810N1940
		GMV-ND100PLS/C-T	CM810N1970	GMV-ND140PLS/C-T	CM810N1930
		GMV-ND112PLS/C-T	CM810N1950	-	-
		Part code	Quantity	Part code	Quantity
10	Bottom Cover Plate	01265343	1	01265343	1
11	Electric Box Assy	100002064928	1	100002064928	1
12	Radiator	430034060043	1	430034060043	1
13	Filter Board	300020060016	1	300020060016	1
14	Terminal Board	42011106	1	42011106	1
15	Terminal Board	42200006000401	1	42200006000401	1
16	Main Board	300002060459	1	300002060459	1
17	Main Board	300002060399	1	300002060399	1
18	Right Side Plate Assy	0131410005501	1	0131410005501	1
19	Hook	02112466	4	02112466	4
20	Water Pump	4313822001	1	4313822001	1
21	Water Level Switch	43002400000502	1	43002400000502	1
22	Pump Drainpipe	04615487	1	04615487	1
23	Strainer	0721304401	2	0721304401	2
24	Electronic Expansion Valve	07334468	1	07334468	1
25	Evaporator Assy	011001060474	1	011001060443	1
26	Electric Expand Valve Fitting	4304413215	1	4304413215	1
27	Air Outlet Side Board Assy	02225270	1	02225270	1
28	Top Cover Board Assy	0126534901	1	0126534901	1
29	Left Side Plate Assy	01315299	1	01315299	1
30	Sensor Sub-Assy	39004169G	1	39004169G	1
31	Drain Hose Sub-Assy	05232050	1	05232050	1
32	Corrugated Pipe	05015408	1	05015408	1
33	Display Board	30296000040	1	30296000040	1

Above data is subject to change without notice, pls reference the SP in global service website.

5.4 4-way Cassette Type

Exploded View of GMV-ND28T/A-T, GMV-ND36T/A-T, GMV-ND45T/A-T, GMV-ND50T/A-T, GMV-ND56T/A-T, GMV-ND63T/A-T, GMV-ND71T/A-T, GMV-ND80T/A-T:

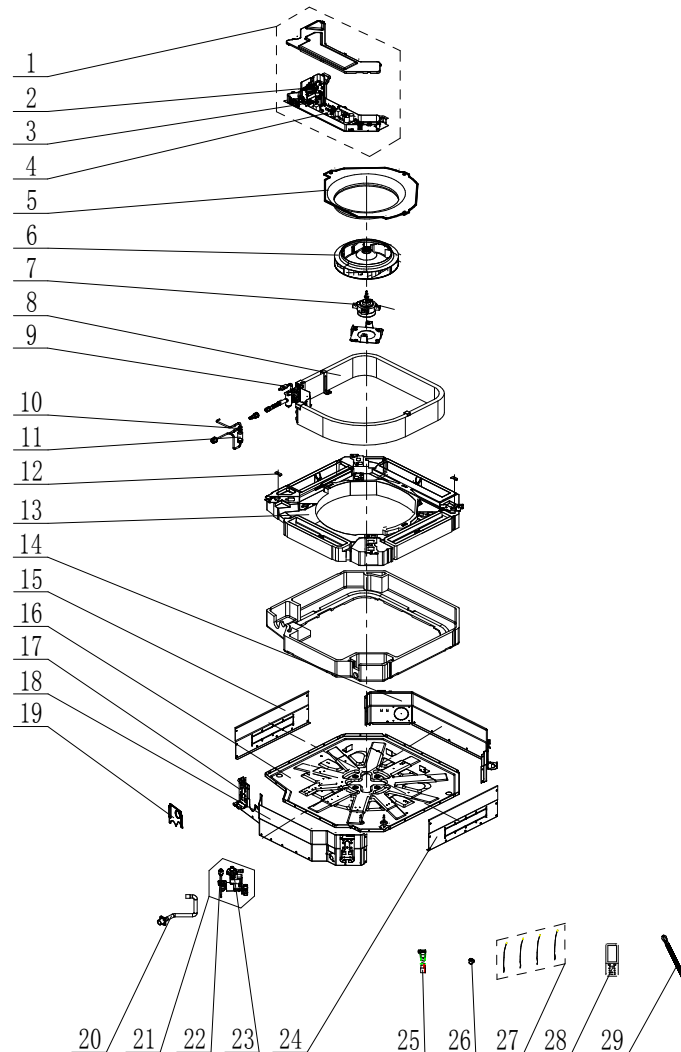

No.	Name of part	For the following unit	
		Unit	Product Code
		GMV-ND28T/A-T	CM500N0380
		Part code	Quantity
1	Electric Box Assy	01394100209	1
2	Terminal Board	4220000001501	1
3	Terminal Board	4201800002601	4
4	Main Board	30226000029	1
5	Diversion Circle	10372701	1
6	Centrifugal Fan	10312721	1
7	Brushless DC Motor	1570410000703	1
8	Evaporator Assy	01024100118	1
9	Strainer	07415200002	1
10	Electronic Expansion Valve	07334463	0
11	Strainer	07414100006	1

No.	Name of part	For the following unit	
		Unit	Product Code
		GMV-ND28T/A-T	CM500N0380
		Part code	Quantity
12	Hook	02112721	1
13	Water Tray Assy	01289400013	1
14	Rear Side Plate	01302732	1
15	Left Side Plate	01302733	1
16	Base Plate Assy	01222701	1
17	Body Installing Plate	01332701	1
18	Front Side Plate	01302731	1
19	Tube Exit Plate Assy	01382717	1
20	Pump Drainpipe	05232721	1
21	Water Pump Assy	15409405	1
22	Water Level Switch	45020216	1
23	Water Pump	43138000068	1
24	Right Side Plate	01302734	1
25	Drain Hose Sub-Assy	007008000001	1
26	Electric Expand Valve Fitting	4304413215	1
27	Sensor Sub-assy	39008000013G	1
28	Remote Controller	30510589	1
29	Corrugated Pipe	0502513401	1

Above data is subject to change without notice, pls refer the SP in global service website.

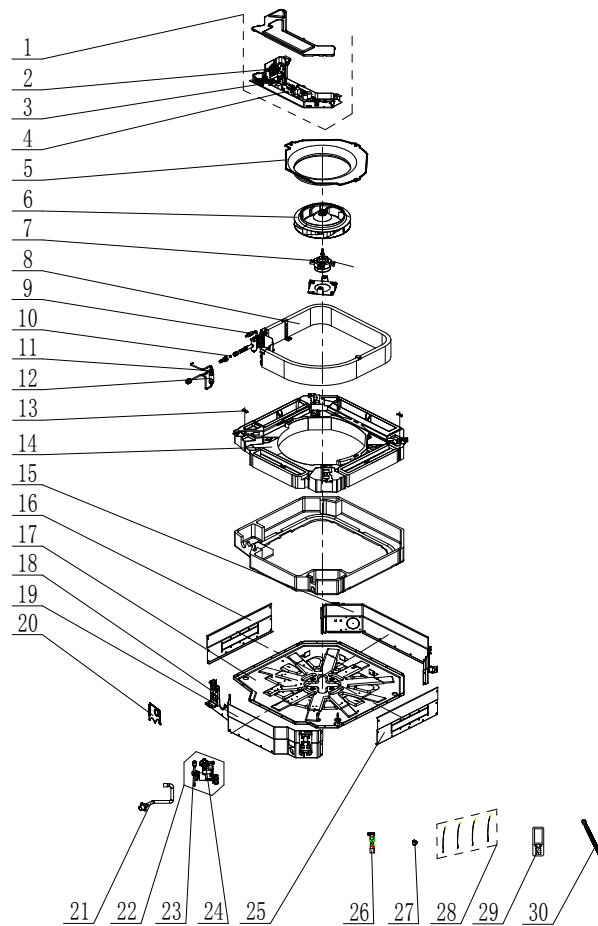

No.	Name of part	For the following unit	
		Unit	Product Code
		GMV-ND36T/A-T	CM500N0390
		Part code	Quantity
1	Electric Box Assy	01394100209	1
2	Terminal Board	4220000001501	1
3	Terminal Board	4201800002601	4
4	Main Board	30226000029	1
5	Diversion Circle	10372701	1
6	Centrifugal Fan	10312721	1
7	Brushless DC Motor	1570410000703	1
8	Evaporator Assy	01024100113	1
9	Strainer	07415200002	1
10	Filter Sub-Assy	11128633	1
11	Electronic Expansion Valve	07334463	1
12	Strainer	07414100006	1
13	Hook	02112721	1
14	Water Tray Assy	01289400013	1
15	Rear Side Plate	01302732	1
16	Left Side Plate	01302733	1
17	Base Plate Assy	01222701	1

No.	Name of part	For the following unit	
		Unit	Product Code
		GMV-ND36T/A-T	CM500N0390
		Part code	Quantity
18	Body Installing Plate	01332701	1
19	Front Side Plate	01302731	1
20	Tube Exit Plate Assy	01382717	1
21	Pump Drainpipe	05232721	1
22	Water Pump Assy	15409405	1
23	Water Level Switch	45020216	1
24	Water Pump	43138000068	1
25	Right Side Plate	01302734	1
26	Drain Hose Sub-Assy	007008000001	1
27	Electric Expand Valve Fitting	4304413215	1
28	Sensor Sub-assy	39008000013G	1
29	Remote Controller	30510589	-
30	Corrugated Pipe	0502513401	-

Above data is subject to change without notice, pls refer the SP in global service website.

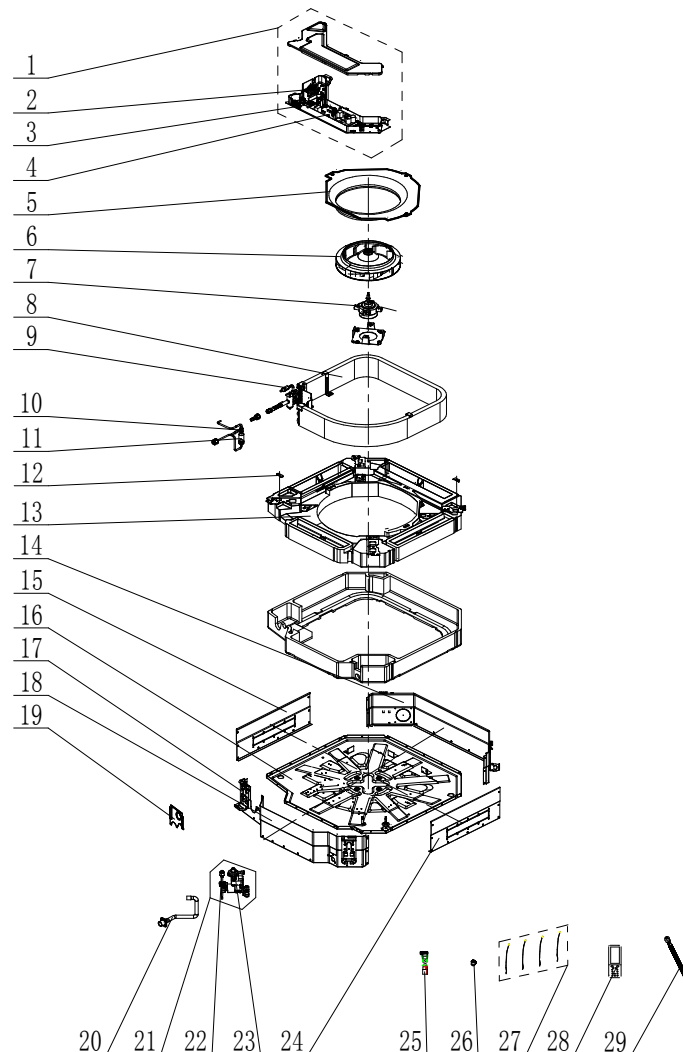

No.	Name of part	For the following unit		For the following unit	
		Unit	Product Code	Unit	Product Code
		GMV-ND45T/A-T	CM500N0400	GMV-ND56T/A-T	CM500N0420
		GMV-ND50T/A-T	CM500N0410	GMV-ND63T/A-T	CM500N0430
		-	-	GMV-ND71T/A-T	CM500N0440
		-	-	GMV-ND80T/A-T	CM500N0450
		Part code	Quantity	Part code	Quantity
1	Electric Box Assy	01394100209	1	01394100209	1
2	Terminal Board	4220000001501	1	4220000001501	1
3	Terminal Board	4201800002601	1	4201800002601	4
4	Main Board	30226000029	1	30226000029	1
5	Diversion Circle	10372701	1	10372701	1
6	Centrifugal Fan	10312721	1	10312705	1
7	Brushless DC Motor	1570410000703	1	1570940000401	1
8	Evaporator Assy	01024100114	1	01024100115	1
9	Strainer	07414100006	1	0741410000601	1
10	Electronic Expansion Valve	07334463	1	07334466	1
11	Strainer	07415200002	1	0741410000601	1
12	Hook	02112721	2	02112721	2
13	Water Tray Assy	01289400013	1	01289400013	1
14	Rear Side Plate	01302732	1	01302703	1
15	Left Side Plate	01302733	1	01302705	1
16	Base Plate Assy	01222701	1	01222701	1
17	Body Installing Plate	01332701	1	01332701	1
18	Front Side Plate	01302731	1	01302701	1
19	Tube Exit Plate Assy	01382717	1	01382715	1
20	Pump Drainpipe	05232721	1	05230026	1
21	Water Pump Assy	15409405	1	01332751	1
22	Water Level Switch	45020216	1	45020216	1
23	Water Pump	43138000068	1	43138000068	1
24	Right Side Plate	01302734	1	01302707	1
25	Drain Hose Sub-Assy	007008000001	1	05339400001	1
26	Electric Expand Valve Fitting	4304413215	1	4304413215	1
27	Sensor Sub-assy	39008000013G	1	39008000013G	1
28	Remote Controller	30510589	1	30510589	1
29	Corrugated Pipe	0502513401	1	0502513401	1

Above data is subject to change without notice, pls reference the SP in global service website.

Exploded View of GMV-ND90T/A-T, GMV-ND100T/A-T, GMV-ND112T/A-T, GMV-ND125T/A-T, GMV-ND140T/A-T:

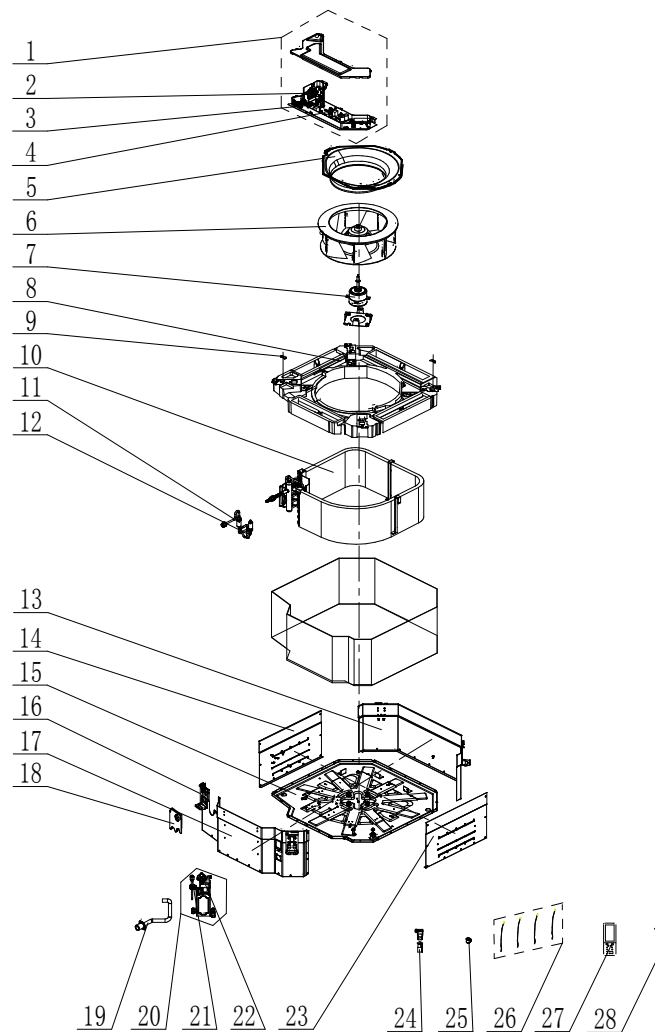

No.	Name of part	For the following unit	
		Unit	Product Code
		GMV-ND90T/A-T	CM500N0460
		GMV-ND100T/A-T	CM500N0470
		GMV-ND112T/A-T	CM500N0480
		GMV-ND125T/A-T	CM500N0480
		GMV-ND140T/A-T	CM800N0550
		Part code	Quantity
1	Electric Box Assy	01394100209	1
2	Terminal Board	42200000001501	1
3	Terminal Board	4201800002601	1
4	Main Board	30226000029	1
5	Diversion Circle	10372722	1
6	Centrifugal Fan	10310101	1
7	Brushless DC Motor	1570940000301	1
8	Water Tray Assy	'01289400013	1
9	Hook	02112721	2

No.	Name of part	For the following unit	
		Unit	Product Code
		GMV-ND90T/A-T	CM500N0460
		GMV-ND100T/A-T	CM500N0470
		GMV-ND112T/A-T	CM500N0480
		GMV-ND125T/A-T	CM500N0480
		GMV-ND140T/A-T	CM800N0550
		Part code	Quantity
10	Evaporator Assy	01024100116	1
11	Strainer	0741410000601	2
12	Electronic Expansion Valve	07334468	1
13	Rear Side Plate	'01302723	1
14	Left Side Plate	01302725	1
15	Base Plate Assy	01222701	1
16	Body Installing Plate	01332701	1
17	Front Side Plate	01302721	1
18	Tube Exit Plate Assy	01382715	1
19	Pump Drainpipe	05230026	1
20	Water Pump Assy	15404100047	1
21	Water Level Switch	45020216	1
22	Water Pump	43138000068	1
23	Right Side Plate	01302727	1
24	Drain Hose Sub-Assy	05339400001	1
25	Electric Expand Valve Fitting	4304413215	1
26	Sensor Sub-Assy	39008000013G	1
27	Remote Controller	30510589	1
28	Corrugated Pipe	0502513401	1

Above data is subject to change without notice, pls reference the SP in global service website.

Exploded View of GMV-ND160T/A-T:

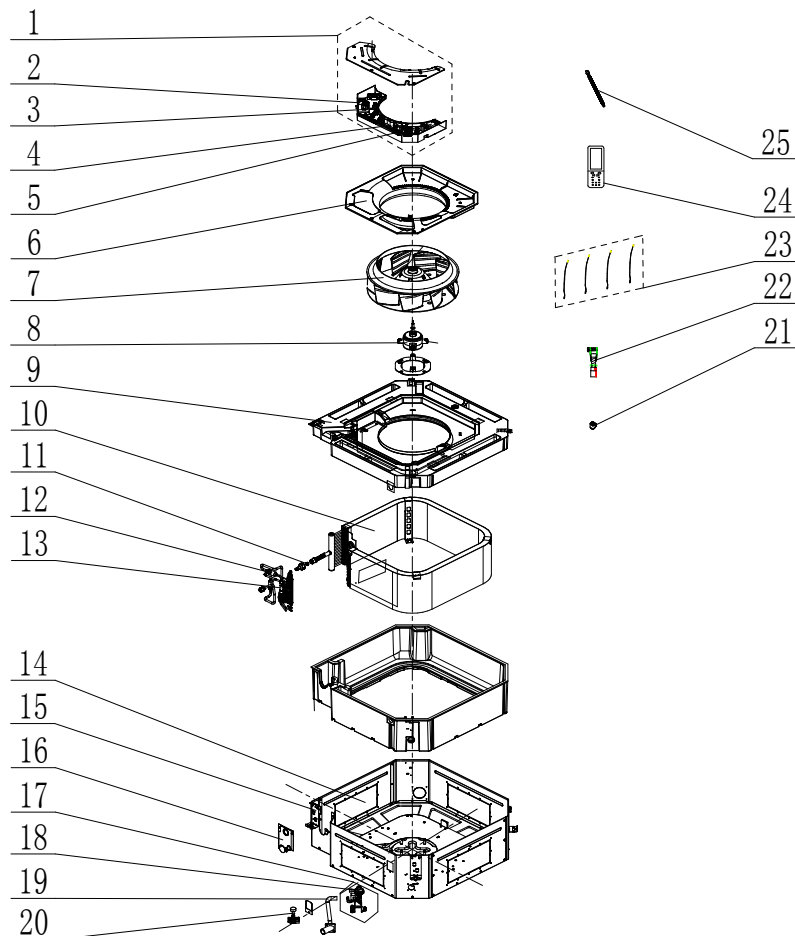

Note:

Details of this model are not issued yet. This list is made according to domestic sales details and cannot be used to place order for accessories. It will be updated once the following details are issued.

No.	Name of part	For the following unit	
		Unit	Product Code
		GMV-ND160T/A-T	CM500N0660
		Part code	Quantity
1	Electric Box Assy	01394100298	1
2	Terminal Board	4201800002601	1
3	Terminal Board	42200000001501	1
4	Main Board	30226000027	1
5	Inductance	43128000014	1
6	Diversion Circle	10479401	1
7	Centrifugal Fan	10429401	1
8	Brushless DC Motor	15709400002	1
9	Water Tray Assy	01289400002	1
10	Evaporator Assy	01024100103	1
11	Filter Sub-Assy	07210029	1
12	Strainer	0741410000601	2
13	Electronic Expansion Valve	07334468	1

No.	Name of part	For the following unit	
		Unit	Product Code
		GMV-ND160T/A-T	CM500N0660
		Part code	Quantity
14	Shell Assy	01519400001	1
15	Body Installing Plate	01329420	1
16	Tube Exit Plate Assy	000067000002	1
17	Water Pump Assy	15404100052	1
18	Water Pump	4313822001	1
19	Drainage Hose(Water Pump)	05339401	1
20	Liquid Level Switch	4501801203	1
21	Electric Expand Valve Fitting	4304413219	1
22	Drain Hose Sub-Assy	05339400001	1
23	Sensor Sub-Assy	39008000012G	1
24	Remote Controller	30510589	1
25	Corrugated Pipe	0502511203	1

Above data is subject to change without notice, pls refer the SP in global service website.

5.5 Compact 4-way Cassette Type

Exploded View of GMV-ND22T/B-T, GMV-ND28T/B-T, GMV-ND36T/B-T, GMV-ND45T/B-T, GMV-ND50T/B-T, GMV-ND56T/B-T:

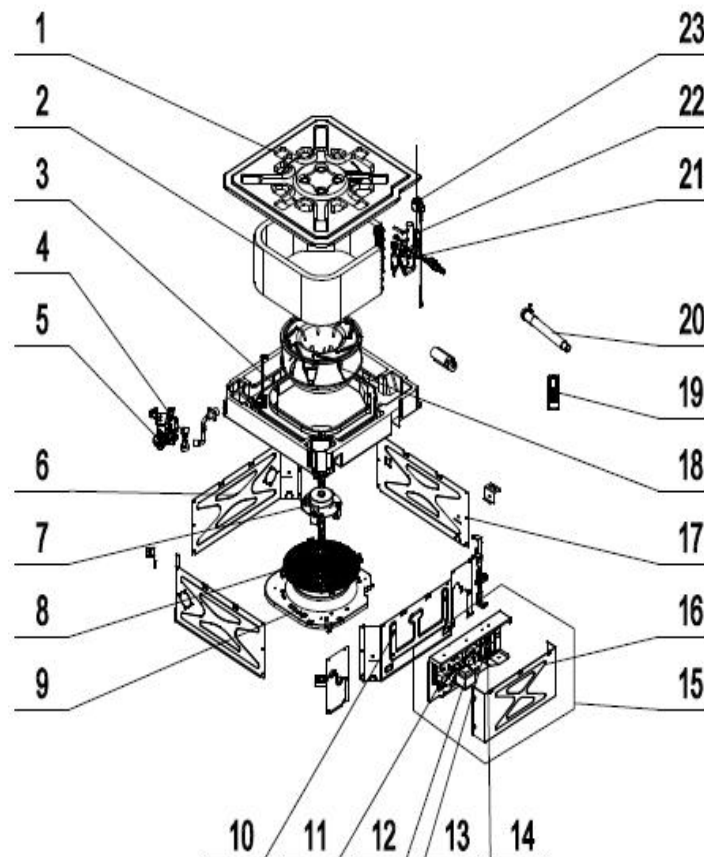

NO	Name of part	For the following unit	
		Unit	Product Code
		GMV-ND22T/B-T	CM500N0610
		GMV-ND28T/B-T	CM500N0620
		GMV-ND36T/B-T	CM500N0630
		GMV-ND45T/B-T	CM500N0640
		GMV-ND50T/B-T	CM500N0600
		GMV-ND56T/B-T	CM500N0650
		Part Code	Quantity
1	Base Plate Assy	02229400007	1
2	Evaporator Assy	01024100137	1
3	Water Tray Assy	01289400004	1
4	Liquid Level Switch	450102013	1
5	Water Pump	43138000024	1
6	Right Side Plate Sub-Assy	01319400013	2
7	Brushless DC Motor	15709400004	1
8	Rear Grill	26909400007	1
9	Diversion Circle	10479400001	1
10	Front Side Plate Sub-Assy	01319400014	1
11	Main Board	30226000029	1
12	Transformer	43118000015	1
13	Terminal Board	42011106	1
14	Terminal Board	4201800002601	1
15	Electric Box Assy	01394100456	1
16	Electric Box Cover	01429400003	1
17	Left Side Plate Sub-Assy	01319400012	1
18	Centrifugal Fan	10429400001	1
19	Remote Controller	30510589	1
20	Drain Hose Sub-Assy	05232050	1
21	Strainer	0741410000601	2
22	Electronic Expansion Valve	07334463	1
23	Electric Expand Valve Fitting	4304413215	1

Above data is subject to change without notice, pls reference the SP in global service website.

5.6 360° Air Discharge Compact Cassette Type

Exploded View of GMV-ND15T/E-T, GMV-ND18T/E-T, GMV-ND22T/E-T, GMV-ND28T/E-T, GMV-ND36T/E-T, GMV-ND45T/E-T, GMV-ND50T/E-T, GMV-ND56T/E-T

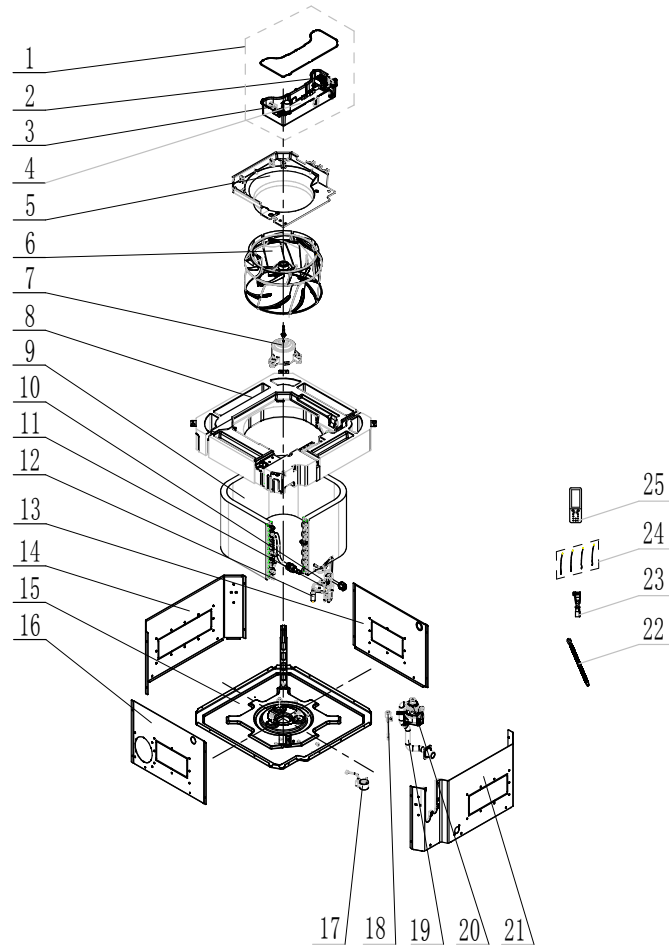

NO	Model	GMV-ND15T/E-T GMV-ND18T/E-T GMV-ND22T/E-T GMV-ND28T/E-T GMV-ND36T/E-T GMV-ND45T/E-T GMV-ND50T/E-T GMV-ND56T/E-T	Qty
	Product Code	CM500N1690 CM500N1700 CM500N1350 CM500N1340 CM500N1330 CM500N1310 CM500N1320 CM500N1300	
	Part Name	Part Code	
1	Electric Box Assy	100002062898	1
2	Terminal Board	42200006000401	1
3	Terminal Board	42011106	1
4	Main Board	300002000782	1
5	Flow Guide Loop	200150060003	1
6	Centrifugal Fan	103003060008	1

NO	Model	GMV-ND15T/E-T GMV-ND18T/E-T GMV-ND22T/E-T GMV-ND28T/E-T GMV-ND36T/E-T GMV-ND45T/E-T GMV-ND50T/E-T GMV-ND56T/E-T	Qty
	Product Code	CM500N1690 CM500N1700 CM500N1350 CM500N1340 CM500N1330 CM500N1310 CM500N1320 CM500N1300	
	Part Name	Part Code	
7	Brushless DC Motor	150104060012	1
8	Water Tray Assy	000069060065	1
9	Evaporator Assy	011001060373	1
10	Strainer	07216221	1
11	Strainer	07213032	1
12	Electronic Expansion Valve	072009000006	1
13	Side Plate	01201006017701	1
14	Side Plate	012010060175	1
15	Seat Board Sub-Assy	017080060023	1
16	Side Plate	012010060177	1
17	Electric expand valve fitting	43040001	1
18	Liquid Level Switch	430024000005	1
19	Drain Pipe	200070060005	1
20	Water Pump PSB-0.024/1.2-A	4313800005802	1
21	Side Plate	012010060176	1
22	Corrugated Pipe	05015408	1
23	Drain Hose Sub-Assy	007008000001	1
24	Sensor Sub-assy	39008000115G	1
25	Remote Controller	30510589	1

Above data is subject to change without notice, pls reference the SP in global service website.

5.7 2-way Cassette Type

Exploded View of GMV-ND28TS/A-T, GMV-ND36TS/A-T, GMV-ND45TS/A-T, GMV-ND50TS/A-T, GMV-ND56TS/A-T, GMV-ND63TS/A-T, GMV-ND71TS/A-T:

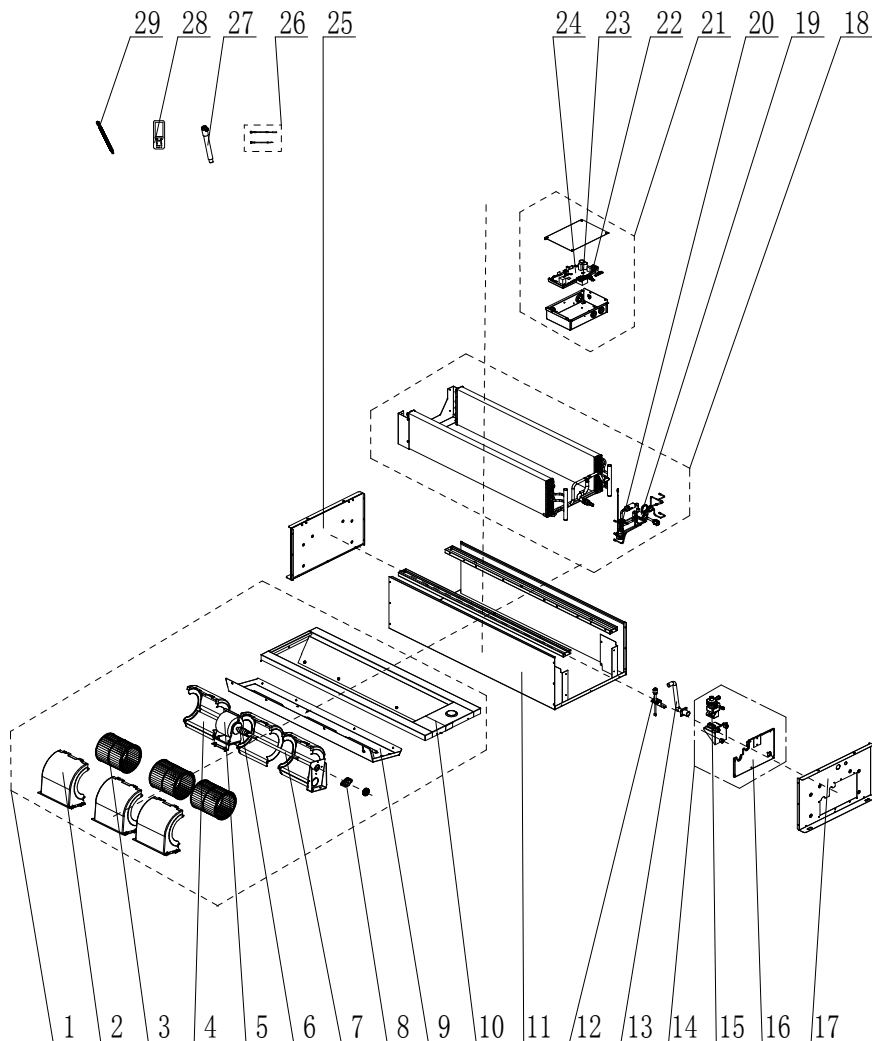

NO	Model	GMV-ND28TS/A-T, GMV-ND36TS/A-T, GMV-ND45TS/A-T, GMV-ND50TS/A-T	GMV-ND56TS/A-T GMV-ND63TS/A-T GMV-ND71TS/A-T	Quantity
	Product Code	CM500N0680 CM500N0690 CM500N0700 CM500N0710	CM500N0720 CM500N0730 CM500N0740	
	Part Name	Part Code	Part Code	
1	Centrifugal Fan Assy	15404100048	15404100048	1
2	Front Volute Casing	22202030	22202030	3
3	Centrifugal Fan	10319051	10319051	3
4	Rear Volute Casing	22202029	22202029	3
7	Fan Motor	15704100003	15704100003	1
8	Joint Slack	73018731	73018731	1
9	Rotary Axis Sub-Assy	73018000075	73018000075	1
10	Support Of Motor Bearing	02285200001	02285200001	1
11	Bearing Holder	26151138	26151138	1
12	Water Tray Sub-Assy	01284100137P	01284100137P	1
13	Water Tray Sub-Assy2	01284100134P	01284100134P	1

NO	Model	GMV-ND28TS/A-T, GMV-ND36TS/A-T, GMV-ND45TS/A-T, GMV-ND50TS/A-T	GMV-ND56TS/A-T GMV-ND63TS/A-T GMV-ND71TS/A-T	Quantity
	Product Code	CM500N0680 CM500N0690 CM500N0700 CM500N0710	CM500N0720 CM500N0730 CM500N0740	
	Part Name	Part Code	Part Code	
14	Base Plate	02224100024	02224100024	1
15	Liquid Level Switch	43002400000501	43002400000501	1
16	Pump Drainpipe	04615487	04615487	1
17	Tube Exit Plate Assy	01344100056	01344100056	1
18	Water Pump	43138220	43138220	1
	Tube-Exit Plate	01344100031	01344100031	1
19	Right Side Plate Sub-Assy	017038000049	017038000049	1
20	Evaporator Assy	01024100094	01024100093	1
21	Strainer	0741410000601	0741410000601	2
22	Electronic Expansion Valve	07334494	07334493	1
23	Terminal Board	42011106	42011106	1
24	Terminal Board	42200006000401	42200006000401	1
25	Main Board	30226000029	30226000029	1
26	Left Side Plate Sub-Assy	01314100104	01314100104	1
27	Sensor Sub-Assy	39008000013G	39008000013G	1
28	Drain Hose Sub-Assy	007008000001	007008000001	1
29	Remote Controller		30510589	1

Above data is subject to change without notice, pls reference the SP in global service website.

5.8 1-way Cassette Type

Exploded View of GMV-ND22TD/A-T, GMV-ND28TD/A-T, GMV-ND36TD/A-T, GMV-ND45TD/A-T, GMV-ND50TD/A-T, GMV-ND56TD/A-T:

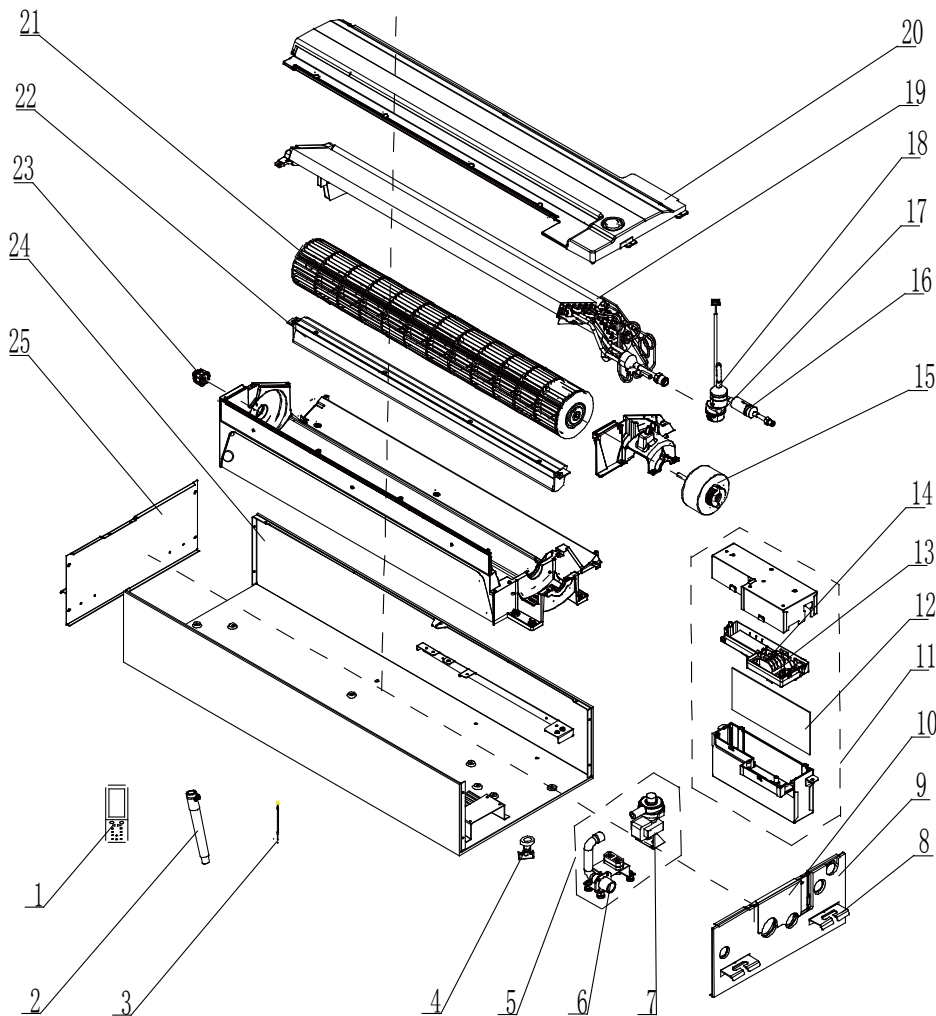

No.	Name of part	For the following unit		For the following unit	
		Unit	Product Code	Unit	Product Code
		GMV-ND28TD/A-T	CM502N0100	GMV-ND36TD/A-T	CM502N0110
		Part code	Quantity	Part code	Quantity
1	Remote Controller	3051012902	1	3051012902	1
2	Drain Hose Sub-Assy	05232050	1	05232050	1
3	Temperature Sensor	39008000079G	1	39008000079G	1
4	Water Level Switch	4501270301	1	4501270301	1
5	Water Pump Assy	15404100005	1	15404100005	1
6	Pump Drainpipe	26905288	1	26905288	1
7	Water Pump	43138220	1	43138220	1
8	Hook	02112466	4	02112466	4
9	Right Side Plate Sub-Assy	01314100023	1	01314100023	1
10	Tube Exit Plate Assy	01344100020	1	01344100020	1
11	Electric Box Assy	01394100396	1	01394100396	1
12	Main Board	30226000029	1	30226000029	1
13	Terminal Board	4201026603	1	4201026603	1

No.	Name of part	For the following unit		For the following unit	
		Unit	Product Code	Unit	Product Code
		GMV-ND28TD/A-T	CM502N0100	GMV-ND36TD/A-T	CM502N0110
		Part code	Quantity	Part code	Quantity
14	Terminal Board	4201800002601	1	4201800002601	1
15	Brushless DC Motor	1501214301	1	1501214301	1
16	Strainer	0741410000601	1	0741410000601	1
17	Electronic Expansion Valve	07334492	1	07334492	1
18	Filter	07415210	1	07415210	1
19	Evaporator Assy	0102410009501	1	0102410009501	1
20	Water Tray Sub-Assy	01284100011	1	01284100011	1
21	Cross Flow Fan	10454100001	1	10454100001	1
22	Helicoid Tongue sub-assy	02224100007	1	02224100007	1
23	O-Gasket of Cross Fan Bearing	76512203	1	76512203	1
24	Chassis Assy	01194100007	1	01194100007	1
25	Left Side Plate Sub-Assy	01314100022	1	01314100022	1

Above data is subject to change without notice, pls reference the SP in global service website.

No.	Name of part	For the following unit		For the following unit	
		Unit	Product Code	Unit	Product Code
		GMV-ND45TD/A-T	CM502N0120	GMV-ND50TD/A-T	CM502N0130
		Part code	Quantity	Part code	Quantity
1	Remote Controller	3051012902	1	3051012902	1
2	Drain Hose Sub-Assy	05232050	1	05232050	1
3	Temperature Sensor	39008000079G	1	39008000079G	1
4	Water Level Switch	4501270301	1	4501270301	1
5	Water Pump Assy	15404100005	1	15404100005	1
6	Pump Drainpipe	26905288	1	26905288	1
7	Water Pump	43138220	1	43138220	1
8	Hook	02112466	4	02112466	4
9	Right Side Plate Sub-Assy	01314100023	1	01314100023	1
10	Tube Exit Plate Assy	01344100020	1	01344100020	1
11	Electric Box Assy	01394100396	1	01394100396	1
12	Main Board	30226000029	1	30226000029	1
13	Terminal Board	4201026603	1	4201026603	1
14	Terminal Board	4201800002601	1	4201800002601	1
15	Brushless DC Motor	1501214301	1	1501214301	1
16	Strainer	0741410000601	1	0741410000601	1
17	Electronic Expansion Valve	07334494	1	07334494	1
18	Filter	07415210	1	07415210	1
19	Evaporator Assy	01024100014	1	01024100014	1
20	Water Tray Sub-Assy	01284100011	1	01284100011	1
21	Cross Flow Fan	10454100001	1	10454100001	1

No.	Name of part	For the following unit		For the following unit	
		Unit	Product Code	Unit	Product Code
		GMV-ND45TD/A-T	CM502N0120	GMV-ND50TD/A-T	CM502N0130
		Part code	Quantity	Part code	Quantity
22	Helicoid Tongue sub-assy	02224100007	1	02224100007	1
23	O-Gasket of Cross Fan Bearing	76512203	1	76512203	1
24	Chassis Assy	01194100007	1	01194100007	1
25	Left Side Plate Sub-Assy	01314100022	1	01314100022	1

Above data is subject to change without notice, pls reference the SP in global service website.

No.	Name of part	For the following unit	
		Unit	Product Code
		GMV-ND56TD/A-T	CM502N0171
		Part code	Quantity
1	Remote Controller	3051012902	1
2	Drain Hose Sub-Assy	05232050	1
3	Temperature Sensor	39008000079G	1
4	Water Level Switch	4501270301	1
5	Water Pump Assy	15404100005	1
6	Pump Drainpipe	26905288	1
7	Water Pump	43138220	1
8	Hook	02112466	4
9	Right Side Plate Sub-Assy	01314100023	1
10	Tube Exit Plate Assy	01344100020	1
11	Electric Box Assy	01394100396	1
12	Main Board	30226000029	1
13	Terminal Board	4201026603	1
14	Terminal Board	4201800002601	1
15	Brushless DC Motor	1501214301	1
16	Strainer	0741410000601	1
17	Electronic Expansion Valve	07334494	1
18	Filter	07415210	1
19	Evaporator Assy	01024100014	1
20	Water Tray Sub-Assy	01284100011	1
21	Cross Flow Fan	10454100001	1
22	Helicoid Tongue sub-assy	02224100007	1
23	O-Gasket of Cross Fan Bearing	76512203	1
24	Chassis Assy	01194100007	1
25	Left Side Plate Sub-Assy	01314100022	1

Above data is subject to change without notice, pls reference the SP in global service website.

5.9 Floor Ceiling Type

Exploded View of GMV-ND28ZD/A-T, GMV-ND36ZD/A-T, GMV-ND50ZD/A-T, GMV-ND56ZD/A-T :

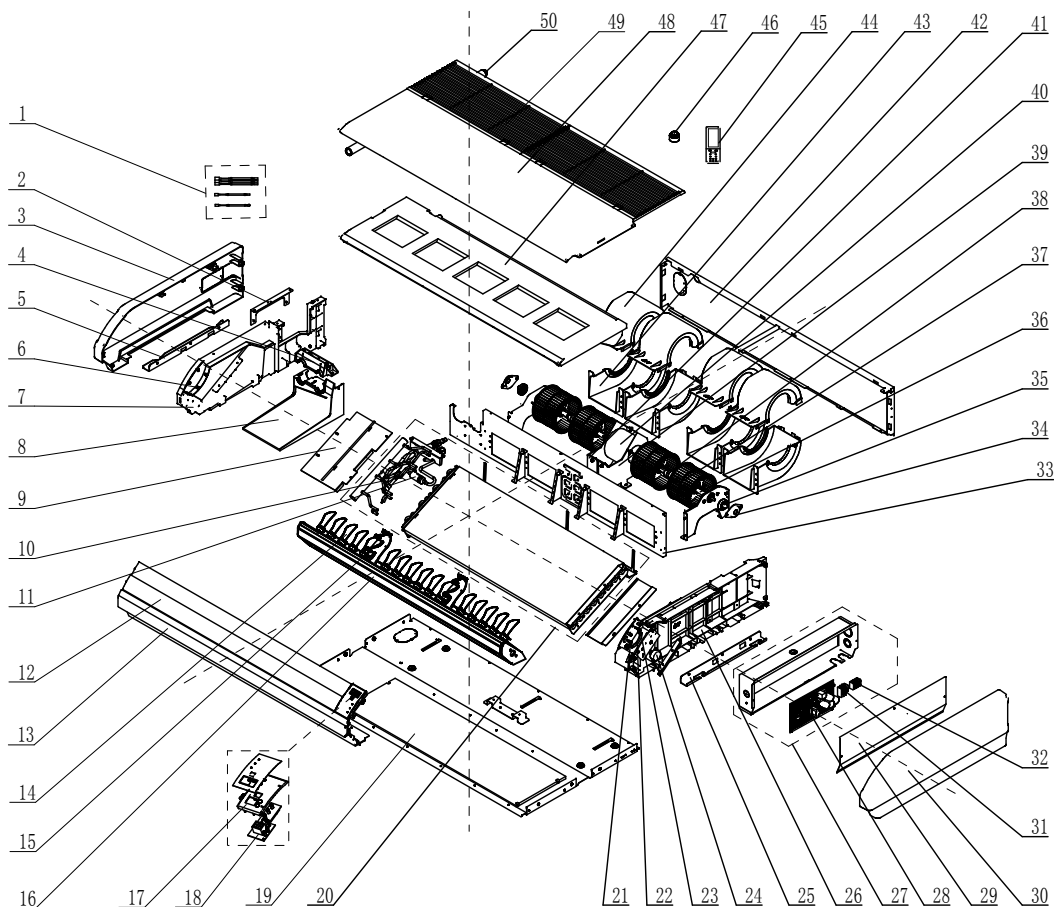

No.	Name of part	For the following unit	
		Unit	Product Code
		GMV-ND28ZD/A-T	CM600N0350
		GMV-ND36ZD/A-T	CM600N0360
		GMV-ND50ZD/A-T	CM600N0320
		GMV-ND56ZD/A-T	CM600N0400
		Part code	Quantity
1	Sensor Sub-assy	39008000101G	1
2	Connection Board	2229406	1
3	Right Cover Plate	26909444	1
4	Plate Board of Water Releasing Flume	26909442	1
5	Installation Supporting Frame	1809402	1
6	Axile Bush	10542704	2
7	Right Side Plate Sub-Assy	1319429	1
8	Water Releasing Flume	02284106P	1
9	Connection Board	1344115	1
10	Electronic Expansion Valve	7334463	1
11	Strainer	741410000601	2
12	Guide Louver	10619403	2
13	Front Connection Board	01349414P	1
14	Air Louver	10619404	16
15	Rotating Shaft	26909430	4

No.	Name of part	For the following unit	
		Unit	Product Code
		GMV-ND28ZD/A-T	CM600N0350
		GMV-ND36ZD/A-T	CM600N0360
		GMV-ND50ZD/A-T	CM600N0320
		GMV-ND56ZD/A-T	CM600N0400
		Part code	Quantity
16	Guide Louver Supporter Sub-assy	0180941601	1
17	Fixed Mount	26909426R	1
18	Display Board	30294000009	1
19	Rear Side Plate Assy	01319400008	1
20	Evaporator Assy	01024100126(28)	1
		01024100096(36, 50)	
21	Rotating Shaft	26909413	1
22	Connecting Rod	26909411	1
23	Rotating Shaft	26909412	1
24	Stepping Motor	1521240206	1
25	Installation Supporting Frame	01809401	1
26	Left Side Plate Sub-Assy	01319428	1
27	Electric Box Assy	01394100343	1
28	Main Board	30226000029	1
29	Electric Box Cover	01429420	1
30	Left Cover Plate	26909443	1
31	Terminal Board	42011106	1
32	Terminal Board	4201800002601	1
33	Mid-clapboard sub-assy	01249400004	1
34	Support Of Motor Bearing	01792408	2
35	O-Gasket of Bearing	76512404	2
36	Rotary Axis Sub-Assy	73018000037	2
37	Centrifugal Fan	10425200	4
38	Joint Slack	73018731(36, 50)	2
39	Supporter	01809400024	1
40	Fan Motor	15704100001	1
41	Supporter	01809400023	1
42	Rear Connection board	01349422	1
43	Front Volute Casing	26905205	4
44	Rear Volute Casing	26905206	4
45	Remote Controller	30510589	1
46	Electric expand valve fitting	4304413203	1
47	Water Tray Assy	01289404	1
48	Top Cover Board Sub-assy	01269409	1
49	Front Grill sub-assy	01579403	2
50	Drainage Pipe Sub-assy	05235434	1

Above data is subject to change without notice, pls reference the SP in global service website.

Exploded View of GMV-ND63ZD/A-T, GMV-ND71ZD/A-T, GMV-ND90ZD/A-T:

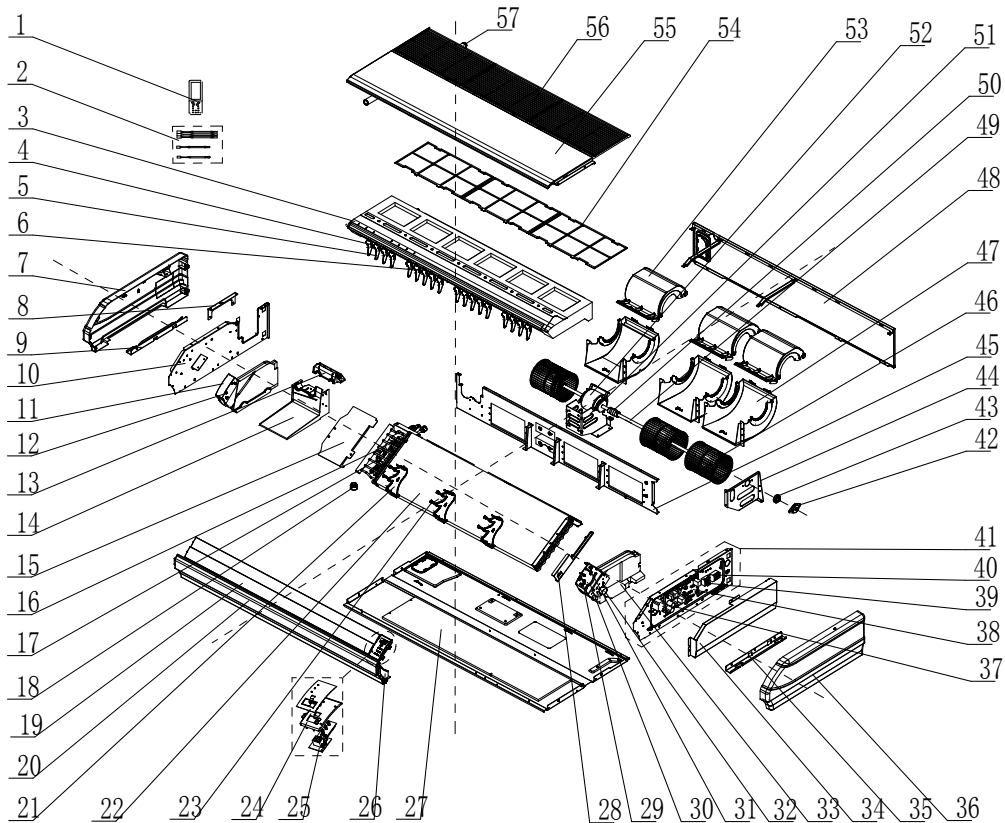

No.	Name of part	For the following unit	
		Unit	Product Code
		GMV-ND63ZD/A-T	CM600N0410
		GMV-ND71ZD/A-T	CM600N0370
		GMV-ND90ZD/A-T	CM600N0330
		Part code	Quantity
1	Remote Controller	30510589	1
2	Sensor Sub-assy	39008000100G	1
3	Water Tray Assy	01289405	1
4	Swing Lever	10582008	2
5	Air Louver	26909418	18
6	Swing Lever	10582009	2
7	Right Cover Plate	26909422	1
8	Connection Board	02229406	1
9	Installation Supporting Frame	01809402	1
10	Right Side Plate Sub-Assy	01319408	1
11	Right Foam Assy	12509425	1
12	Axile Bush	10542704	2
13	Plate Board of Water Releasing Flume	26909442	1
14	Water Releasing Flume	26909441	1
15	connected board (evaporator)	01344108	1
16	Strainer	0741410000601	2
17	Electronic Expansion Valve	07334466	1

No.	Name of part	For the following unit	
		Unit	Product Code
		GMV-ND63ZD/A-T	CM600N0410
		GMV-ND71ZD/A-T	CM600N0370
		GMV-ND90ZD/A-T	CM600N0330
		Part code	Quantity
18	Electric expand valve fitting	4304413203	1
19	Guide Louver	26909432	2
20	Front Connection Board	01349408P	1
21	Supporter	26909409	3
22	Evaporator Assy	01024100104	1
23	Rotating Shaft	26909430	6
24	Fixed Mount	26909426R	1
25	Display Board	30294000009	1
26	Front Connection Board Foam Assy	12509424	1
27	Rear Side Plate Assy	01319400005	1
28	Water Releasing Flume	02289402P	1
29	Rotating Shaft	26909413	1
30	Connecting Rod	6909411	1
31	Rotating Shaft	26909412	1
32	Stepping Motor	1521240206	1
33	Left Foam Assy	12509408	1
34	Electric Box Cover	01429410P	1
35	Installation Supporting Frame	01809401	1
36	Left Cover Plate	26909416	1
37	Inductance	43128000014	1
38	Main Board	30226000027	1
39	Terminal Board	42011106	1
40	Terminal Board	4201800002601	1
41	Electric Box Assy	01394100344	1
42	Support Of Motor Bearing	01792408	1
43	O-Gasket of Bearing	76512404	1
44	Bracket 1	01809404	1
45	Clapboard Sub-Assy	01249400002	1
46	Centrifugal fan	1041410101	3
47	Front volute casing	26905208	3
48	Rear Connection board	01349418	1
49	Rotary Axis Sub-Assy	73018052	1
50	Joint Slack	73018731	1
51	Motor Support Sub-Assy	01809400029	1
52	Brushless DC Motor	15705200005	1
53	Rear volute casing	26909419	3

No.	Name of part	For the following unit	
		Unit	Product Code
		GMV-ND63ZD/A-T	CM600N0410
		GMV-ND71ZD/A-T	CM600N0370
		GMV-ND90ZD/A-T	CM600N0330
Part code	Quantity		
54	Filter	11126002	1
55	Top Cover Board Sub-assy	01269405	1
56	Front Grill sub-assy	01579402	3
57	Drainage Pipe Sub-assy	05235434	1

Above data is subject to change without notice, pls reference the SP in global service website.

Exploded View of GMV-ND112ZD/A-T, GMV-ND125ZD/A-T, GMV-ND140ZD/A-T:

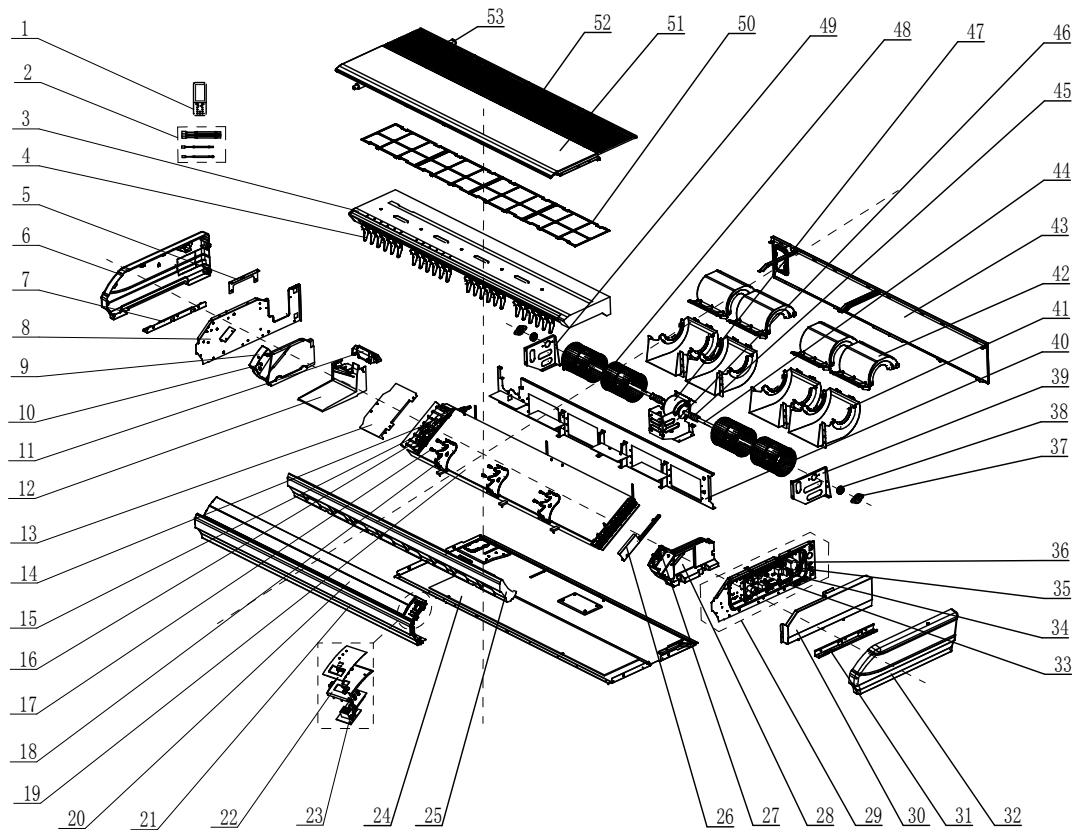

No.	Name of part	For the following unit	
		Unit	Product Code
		GMV-ND112ZD/A-T	CM600N0380
		GMV-ND125ZD/A-T	CM600N0390
		GMV-ND140ZD/A-T	CM600N0340
		GMV-ND160ZD/A-T	CM600N0500
		Part code	Quantity
1	Remote Controller	30510589	1
2	Sensor Sub-assy	39008000100G	1
3	Water Tray Assy	01289401	1
4	Air Louver	26909418	24
5	Connection Board	02229406	1
6	Right Cover Plate	26909422	1
7	Installation Supporting Frame	01809402	1
8	Right Side Plate Sub-Assy	01319408	1
9	Right Foam Assy	12509425	1
10	Axile Bush	10542704	2
11	Plate Board of Water Releasing Flume	26909442	1
12	Water Releasing Flume	26909441	1
13	connected board (evaporator)	01344108	1
14	Strainer	0741410000601	2
15	Electronic Expansion Valve	07334468	1
16	Electric expand valve fitting	4304413203	1
17	Rotating Shaft	26909430	6
18	Supporter	26909409	3
19	Evaporator Assy	01024100105	1
20	Guide Louver	10619405	2
21	Front Connection Board	01349404P	1
22	Fixed Mount	26909426R	1
23	Display Board	30294000009	1
24	Rear Side Plate Sub-Assy	01319442	1
25	Front Connection Board Foam Assy	12509434	1
26	Water Releasing Flume	02289402P	1
27	Stepping Motor	1521240206	2
28	Left Foam Assy	12509437	1
29	Electric Box Assy	01394100344	1
30	Electric Box Cover	01429410P	1
31	Installation Supporting Frame	01809421	1
32	Left Cover Plate	26909416	1
33	Main Board	30226000027	1
34	Terminal Board	42011106	1
35	Terminal Board	4201800002601	1

No.	Name of part	For the following unit	
		Unit	Product Code
		GMV-ND112ZD/A-T	CM600N0380
		GMV-ND125ZD/A-T	CM600N0390
		GMV-ND140ZD/A-T	CM600N0340
		GMV-ND160ZD/A-T	CM600N0500
		Part code	Quantity
36	Inductance	43128000014	1
37	Support Of Motor Bearing	01792408	2
38	O-Gasket of Bearing	76512404	2
39	Bracket 1	01809404	1
40	Clapboard Sub-Assy	01249400006	1
41	Front volute casing	26905208	4
42	Rear volute casing	26909419	4
43	Rear Connection board	01349419	1
44	Rotary Axis Sub-Assy	73018052	2
45	Joint Slack	73018731	2
46	Motor Support Sub-Assy	0180940002901	1
47	Brushless DC Motor	157094000005	1
48	Centrifugal fan	1041410101	4
49	Supporter	01809403	1
50	Filter	11126002	1
51	Top Cover Board Sub-assy	01269400002	1
52	Front Grill sub-assy	01579401	4
53	Drainage Pipe Sub-assy	05235434	1

Above data is subject to change without notice, pls reference the SP in global service website.

5.10 Fresh air Processing Unit

Exploded View of GMV-NX140P/A(X1.2)-K:

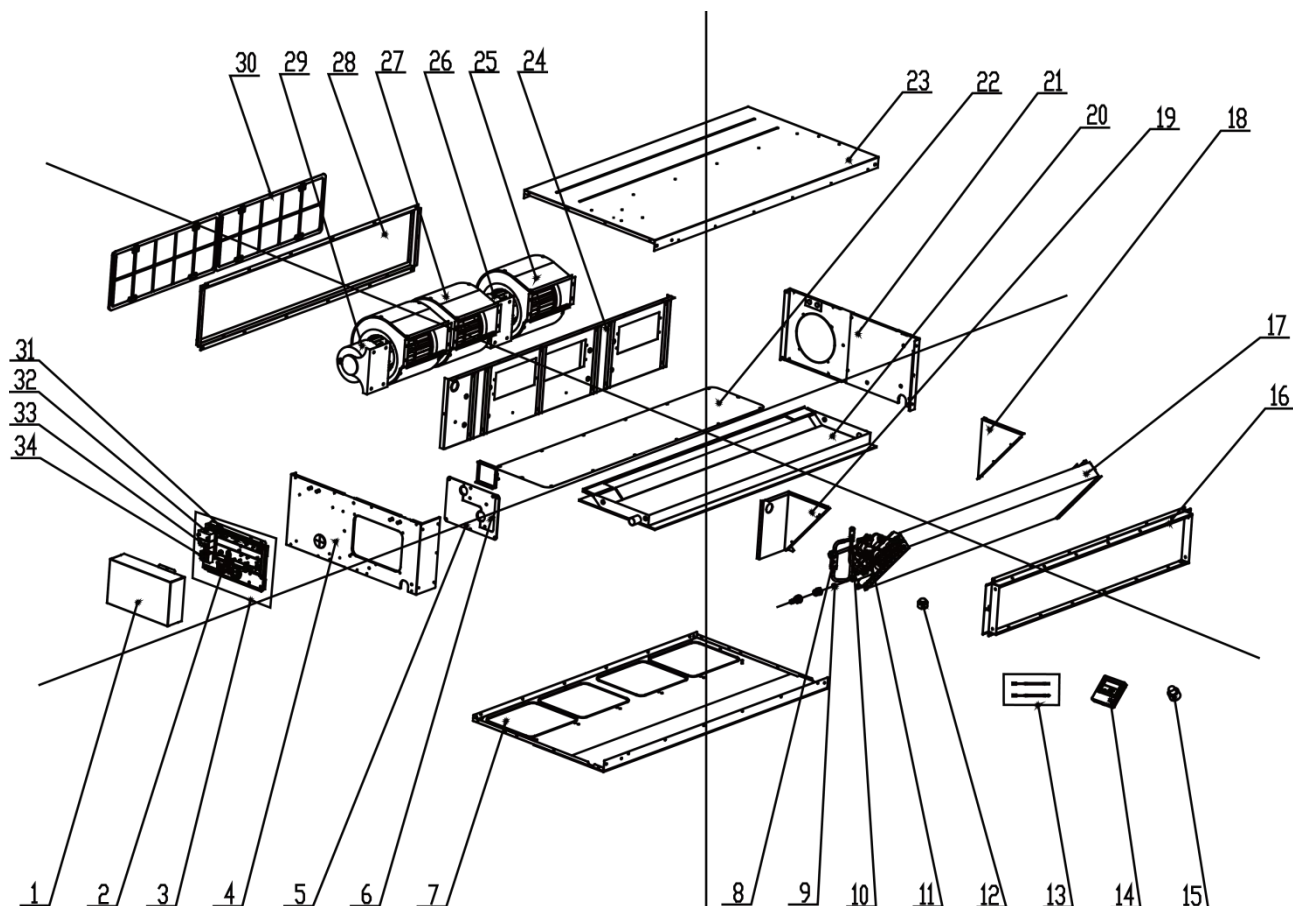

NO.	Model	GMV-NX140P/A(X1.2)-K	Quantity
	Product Code	CM800N3610	
	Part Name	Part Code	
1	Electric Box Cover	01424100071	1
2	Terminal Board	42011106	1
3	Electric Box Assy	01394100199	1
4	Left Side Plate Assy	01314100058	1
5	Seal Of Left Side Plate Sub-Assy	01495212	1
6	Seal Of Connection Pipe	01495213	1
7	Bottom Cover Plate Assy	0125860301	1
8	Strainer	0741410000601	1
9	Filter Sub-Assy	07210028	1
10	Electronic Expansion Valve	07334412	1
11	Filter	07415210	1
12	Electric Expand Valve Fitting	4304413219	1
13	Sensor sub-assy	39004167G	1
14	Display Board	30296106	1
15	Choke Plug of Water Pipe	76712454	1
16	Border Plate of Air Outlet Sub-Assy	01374100036	1
17	Evaporator Assy	01024100061	1
18	Evaporator	01805221	1
19	Left Evaporator Support	01804100006	1
20	Water Tray Assy	01285229	1
21	Right Side Plate Assy	01308679	1

NO.	Model	GMV-NX140P/A(X1.2)-K	Quantity
	Product Code	CM800N3610	
	Part Name	Part Code	
22	Cover Of Air-In	01258602	1
23	Top Cover Board Assy	01264625	1
24	Fan Motor Mounting Plate Sub-Assy	01325293	1
25	Blower	15018603	2
26	Fan Motor	1570520901	1
27	Blower	15018604	1
28	Air intake side-board Sub-assy	01375221	1
29	Fan Motor	1570521001	1
30	Filter Sub-Assy	11725205	2
31	Main Board	30226000052	1
32	Capacitor CBB61	33010056	1
33	Capacitor CBB61	33010064	1
34	Terminal Board	4201800002601	1

Above data is subject to change without notice, pls reference the SP in global service website.

Exploded View of GMV-NX224P/A(X2.0)-M:

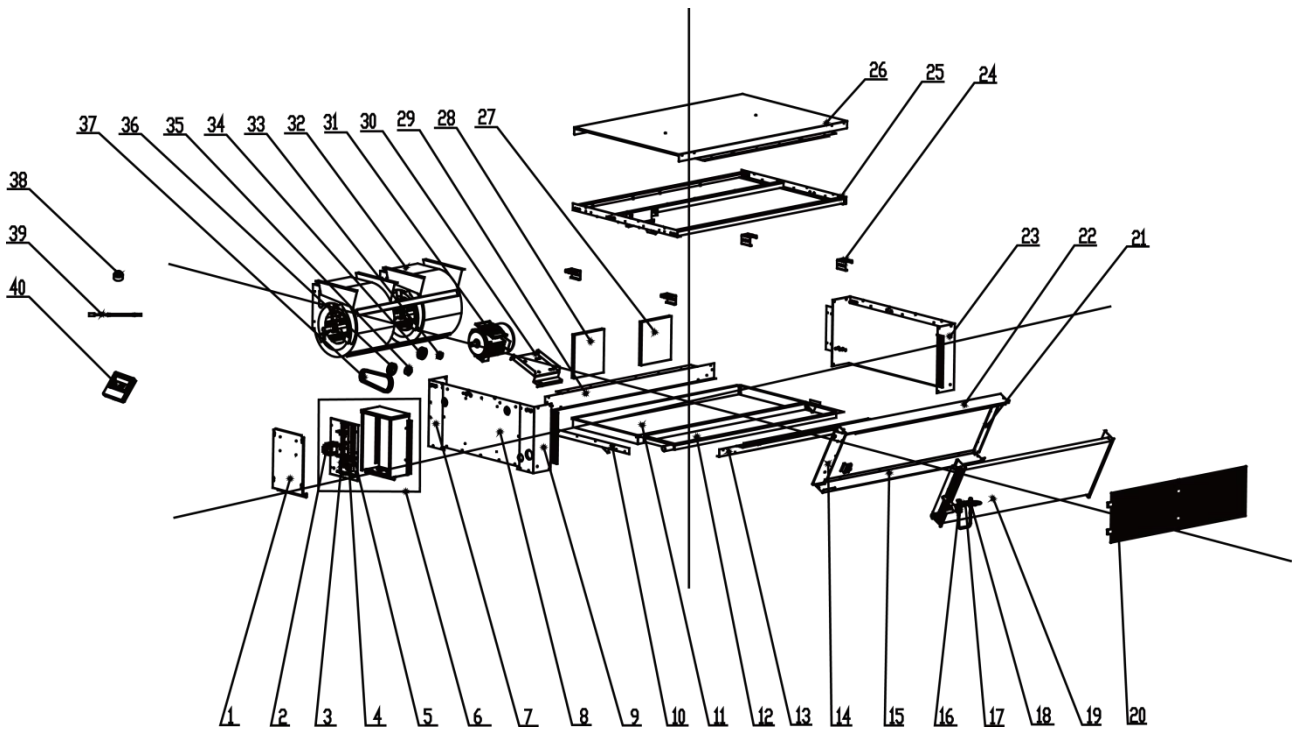

NO.	Model	GMV-NX224P/A(X2.0)-M	Quantity
	Product Code	CM800N3620	
	Part Name	Part Code	
1	Electric Box Cover	01419141	1
2	AC Contactor	44010232	1
3	Terminal Board	420100071	1
4	Terminal Board	4201800002601	1
5	Main Board	30226000052	1
6	Electric Box Assy	01394100202	1
7	Right Side Plate Sub-Assy	01309105	1
8	Access panel sub-assy	01544126	1
9	Right Side Plate Sub-Assy	01314209	1
10	Side beam assy	01874178	1

NO.	Model	GMV-NX224P/A(X2.0)-M	Quantity
	Product Code	CM800N3620	
	Part Name	Part Code	
11	Chassis Sub-assy	01194136	1
12	Water Collecting Tray Assy	01284142	1
13	Front Frame sub- assy	01874184	1
14	Air Guard	01354112	1
15	Base plate (evaporator)	01079114	1
16	Filter	07415210	1
17	Strainer	0741410000601	1
18	Electronic Expansion Valve	07334390	1
19	Evaporator Assy	1024100064	1
20	Filter Sub-Assy	11129070	2
21	Air Guard	01354111	1
22	Cover Plate Sub-Assy of Evaporator	01094109	1
23	Left Side Plate Assy	01314208	1
24	Hook	02205302	4
25	Suspending Rack	01729165	1
26	Top Cover Assy	01259106	1
27	Place with a draught of Connection board	01389079	1
28	Place with a draught of Connection board	01389077	1
29	Rear beam sub-assy	01779108	1
30	Motor Retaining Plate Sub-Assy	01845309	1
31	Fan Motor	15018304	1
32	Motor	15009059	1
33	Taper Sleeve	10548211	1
34	Belt Wheel	10548157	1
35	Taper Sleeve	10548218	1
36	Belt Wheel	10548150	1
37	Belt	76318317	2
38	Electric Expand Valve Fitting	4304413219	1
39	Sensor sub-assy	39004165G	1
40	Display Board	30296106	1

Above data is subject to change without notice, pls reference the SP in global service website.

Exploded View of GMV-NX280P/A(X2.5)-M, GMV-NX280P/A(X3.0)-M:

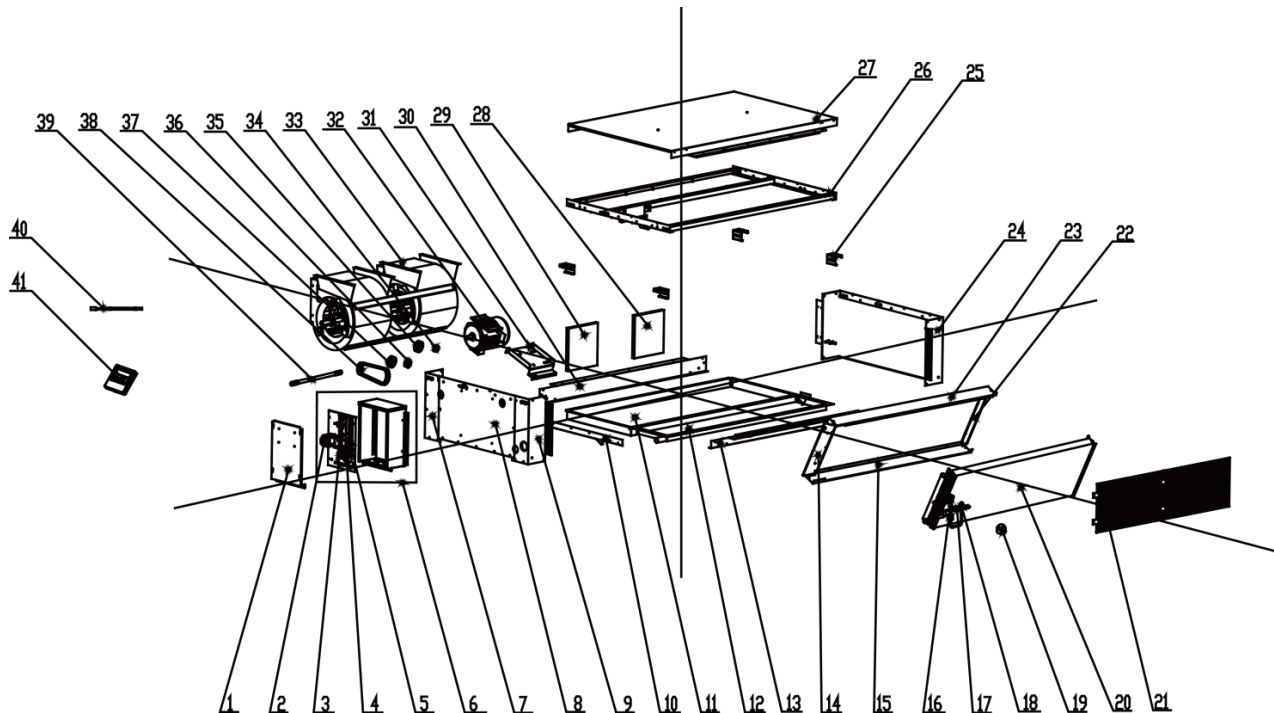

NO.	Model	GMV-NX280P/A(X2.5)-M	GMV-NX280P/A(X3.0)-M	Quantity
	Product Code	CM800N3630	CM800N3630	
	Part Name	Part Code	Part Code	
1	Electric Box Cover	014191411	014191411	1
2	AC Contactor	44010232	44010232	1
3	Terminal Board	420100071	420100071	1
4	Terminal Board	4201800002601	4201800002601	1
5	Main Board	30226000052	30226000052	1
6	Electric Box Assy	01394100202	01394100202	1
7	Right Side Plate Sub-Assy	01309105	01309105	1
8	Access panel sub-assy	01544126	01544126	1
9	Right Side Plate Sub-Assy	01314209	01314209	1
10	Side beam assy	01874178	01874178	1
11	Chassis Sub-assy	01194136	01194136	1
12	Water Collecting Tray Assy	01284142	01284142	1
13	Front Frame sub- assy	01874184	01874184	1
14	Air Guard	01354112	01354112	1
15	Base plate (evaporator)	01079114	01079114	1
16	Filter	07415210	07415210	1
17	Strainer	0741410000601	0741410000601	1
18	Electronic Expansion Valve	07334390	07334390	1
19	Electric Expand Valve Fitting	4304413219	4304413219	1
20	Evaporator Assy	1024100092	1024100092	1
21	Filter Sub-Assy	11129070	11129070	2
22	Air Guard	01354111	01354111	1
23	Cover Plate Sub-Assy of Evaporator	01094109	01094109	1
24	Left Side Plate Assy	01314208	01314208	1
25	Hook	02205302	02205302	4
26	suspending rack	01729165	01729165	1
27	Top Cover Assy	01259106	01259106	1

NO.	Model	GMV-NX280P/A(X2.5)-M	GMV-NX280P/A(X3.0)-M	Quantity
	Product Code	CM800N3630	CM800N3630	
	Part Name	Part Code	Part Code	
28	place with a draught of Connection board	01389079	01389079	1
29	place with a draught of Connection board	01389077	01389077	1
30	Rear beam sub-assy	01779108	01779108	1
31	Motor Retaining Plate Sub-Assy	01845309	01845309	1
32	Fan Motor	15018304	15018304	1
33	Motor	15009059	15009059	1
34	Taper Sleeve	10548211	10548211	1
35	Belt Wheel	10548156	10548157	1
36	Taper Sleeve	10548218	10548218	1
37	Belt Wheel	10548149	10548150	1
38	Belt	76318340	76318317	2
39	Rotating Shaft	10549057	10549057	1
40	Sensor sub-assy	39004165G	39004165G	1
41	Display Board	30296106	30296106	1

Above data is subject to change without notice, pls reference the SP in global service website.

Exploded View of GMV-NX450P/A(X4.0)-M:

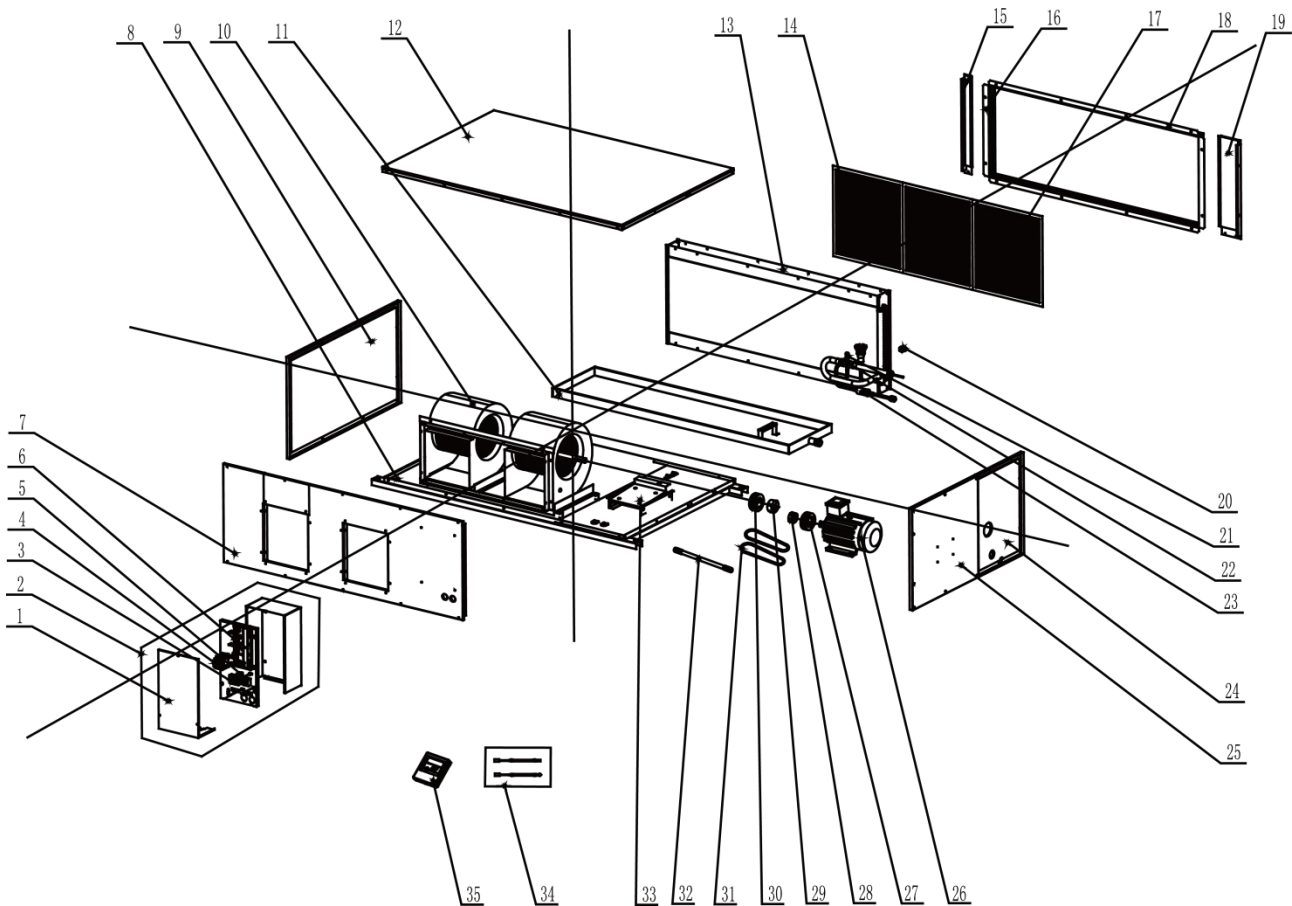

NO.	Model	GMV-NX450P/A(X4.0)-M	Quantity
	Product Code	CM800N3740	
	Part Name	Part Code	
1	Electric Box Cover	01425304P	1
2	Electric Box Assy	01394100243	1

NO.	Model	GMV-NX450P/A(X4.0)-M	Quantity
	Product Code	CM800N3740	
	Part Name	Part Code	
3	Terminal Board	42011043	1
4	AC Contactor	44010232	1
5	Terminal Board	4201800002601	1
6	Main Board	30226000052	1
7	Air Outlet Panel sub-assy	01545213	1
8	Base Frame Assy	01285225	1
9	Side panel sub-assy	01545212	1
10	Motor	15705214	1
11	Water Collecting Tray Assy	01284169	1
12	Top Cover Sub-Assy	01265209	1
13	Evaporator Assy	01024100062	1
14	Filter Sub-Assy	11129079	1
15	Retaining Plate Sub-Assy	01845207	1
16	Longitudinal Beam of return air frame	01875208P	2
17	Filter Sub-Assy	11129078	2
18	Return Air Frame Sub-Assy	01375208P	2
19	Retaining Plate Sub-Assy	01845205	1
20	Electric Expand Valve Fitting	4304413219	1
21	Electronic Expansion Valve	07334390	1
22	Filter	07218603	1
23	Gas Tube Filter	072190511	1
24	Side panel sub-assy	01545208	1
25	Side panel sub-assy	01545210	1
26	Fan Motor	1501861102	1
27	Belt Wheel	10548149	1
28	Taper Sleeve	10548213	1
29	Taper Sleeve	10548218	1
30	Belt Wheel	10548156	1
31	Belt	76318309	2
32	Rotating Shaft	10549057	1
33	Retaining Plate	01845319	1
34	Temperature Sensor	39008042G	1
35	Display Board	30296106	1

Above data is subject to change without notice, pls reference the SP in global service website.

Exploded View of GMV-NDX125P/A-T, GMV-NDX140P/A-T:

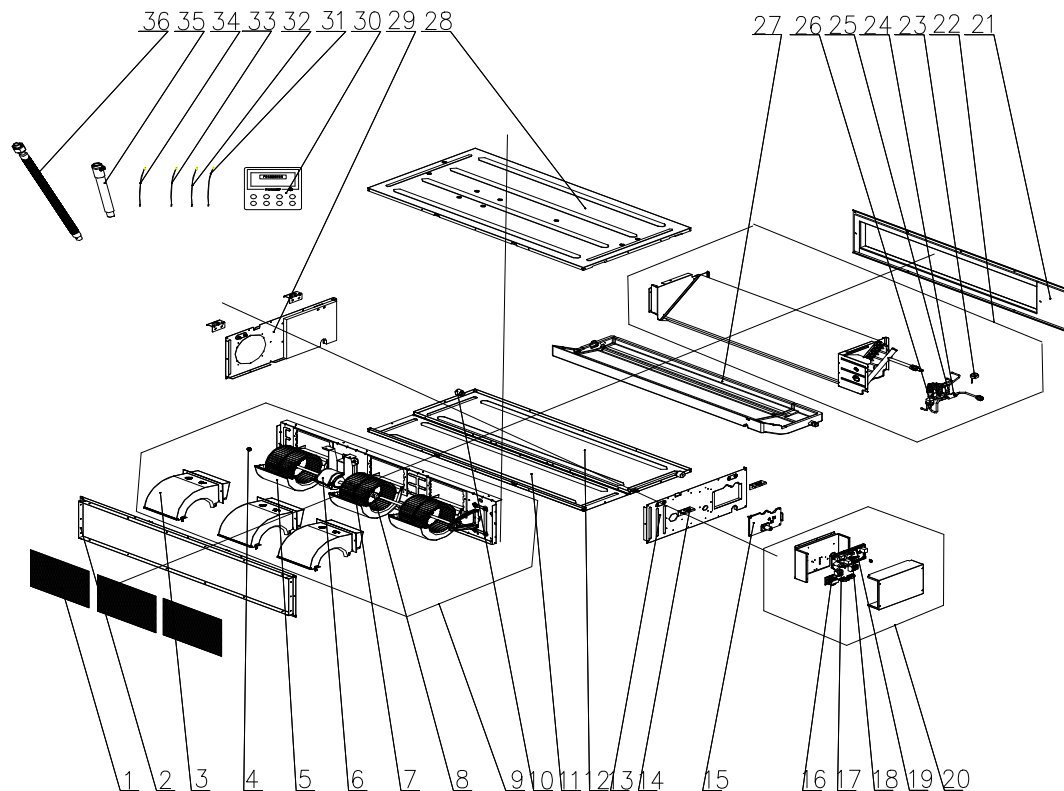

NO.	Model	GMV-NDX125P/A-T	GMV-NDX140P/A-T	Quantity
	Product Code	CM810N1220	CM810N1020	
	Part Name	Part Code	Part Code	
1	Filter Sub-Assy	111001000052	111001000052	3
2	Return Air Frame Sub-Assy	017026000003	017026000003	1
3	Propeller Housing(Upper)	26905200078	26905200078	3
4	Fan Bearing	76512210	76512210	1
5	Propeller Housing(Lower)	26905200079	26905200079	3
6	Brushless DC Motor	1570940000601	1570940000601	1
7	Centrifugal Fan	10455200003	10455200003	3
8	Joint Slack	73018731	73018731	1
9	Centrifugal Fan Assy	000052000028	000052000028	1
10	Choke plug of Drain pipe	76815214	76815214	2
11	Cover plate (Air Return)	01265200123	01265200123	1
12	Bottom Cover Plate	01265200125	01265200125	1
13	Left Side Plate Assy	01315200147	01315200147	1
14	Hook	02112466	02112466	4
15	Seal Plate	01495200043	01495200043	1
16	Reactor	43138000047	43138000047	1
17	Terminal Board	4201115404	4201115404	1
18	Terminal Board	4201800002601	4201800002601	1
19	Main Board	300002000686	300002000686	2
20	Electric Box Assy	100002003006	100002003006	1
21	Air Outlet Frame Assy	01375200023	01375200023	1
22	Evaporator Assy	011001000471	011001000471	1
23	Electric Expand Valve Fitting	4304413215	4304413215	1
24	Strainer	0741410000601	0741410000601	1
25	Electronic Expansion Valve	07334468	07334468	1

NO.	Model	GMV-NDX125P/A-T	GMV-NDX140P/A-T	Quantity
	Product Code	CM810N1220	CM810N1020	
	Part Name	Part Code	Part Code	
26	Strainer	7415210	7415210	1
27	Foam Sub-Assy(Water Tray)	12505200021	12505200021	1
28	Top Cover Board Assy	01264100105	01264100105	1
29	Right Side Plate Assy	01315200148	01315200148	1
30	Display Board	30296000040	30296000040	1
31	Temperature Sensor	3900005910	3900005910	1
32	Temperature Sensor	390000592	390000592	1
33	Temperature Sensor	390000454	390000454	1
34	Temperature Sensor	390002072	390002072	1
35	Drain Hose Sub-Assy	05232050	05232050	1
36	Corrugated Pipe	05015408	05015408	1

Above data is subject to change without notice, pls reference the SP in global service website.

Exploded View of GMV-NDX224P/A-T, GMV-NDX250P/A-T, GMV-NDX280P/A-T:

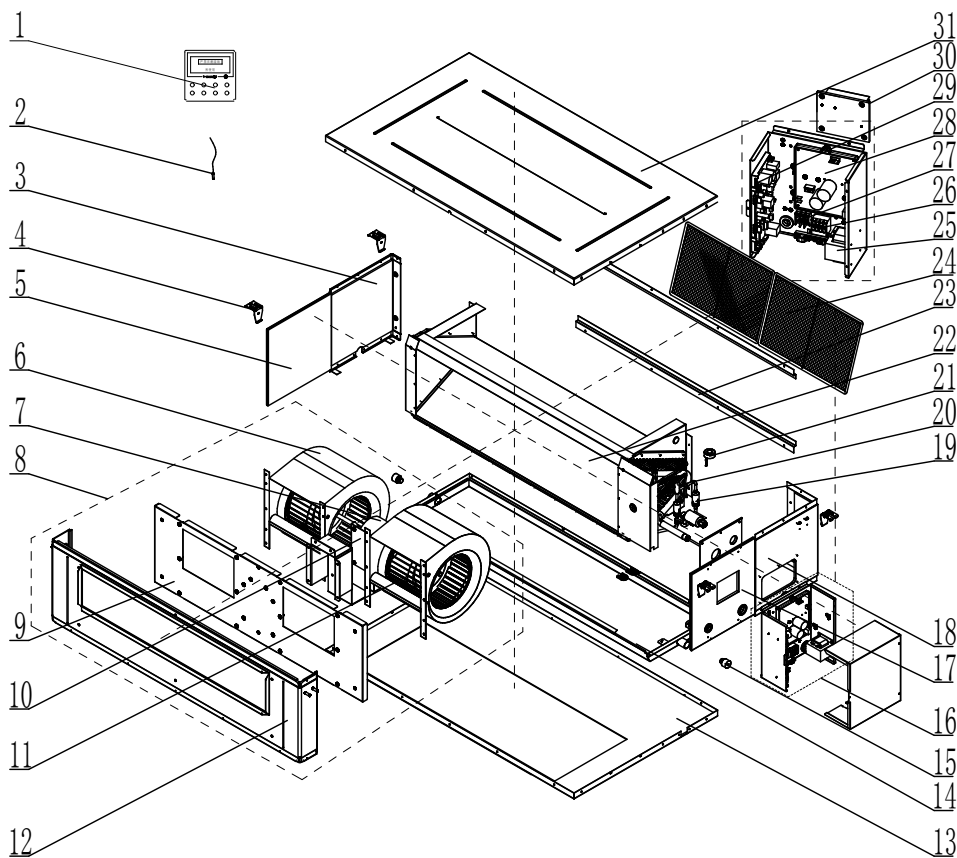

NO.	Model	GMV-NDX224P/A-T	GMV-NDX250P/A-T	GMV-NDX280P/A-T	Quantity
	Product Code	CM810N0260	CM810N1230	CM810N0270	
	Part Name	Part Code	Part Code	Part Code	
1	Display Board	30296000040	30296000040	30296000040	1
2	Sensor Sub-Assy	39004165G	39004165G	39004165G	1
3	Left Side Plate Assy 2	01315367	01315367	01315367	1
4	Hook	02112466	02112466	02112466	4
5	Left Side Plate Sub-Assy 1	01315376	01315376	01315376	1
6	Centrifugal Fan (Left)	1570530601	1570530601	1570530601	1
7	Brushless DC Motor	15704100009	15704100009	15704100009	1

NO.	Model	GMV-NDX224P/A-T	GMV-NDX250P/A-T	GMV-NDX280P/A-T	Quantity
	Product Code	CM810N0260	CM810N1230	CM810N0270	
	Part Name	Part Code	Part Code	Part Code	
8	Centrifugal Fan Assy	15404100075	15404100075	15404100075	1
9	Blower Mounting Plate Sub-Assy	01324100064	01324100064	01324100064	1
10	Motor Support	01805200228	01805200228	01805200228	1
11	Blower(Right)	15705307	15705307	15705307	1
12	Front Side Plate Assy	01314627	01314627	01314627	1
13	Bottom Cover Plate Assy	01265357	01265357	01265357	1
14	Water Tray Assy	01284620	01284620	01284620	1
15	Choke Plug of Water Pipe	76712454	76712454	76712454	2
16	Electric Box Assy	01394100573	01394100573	01394100573	1
17	Right Side Plate Sub-Assy 1	01314100086	01314100086	01314100086	1
18	Right Side Plate Assy	01314321	01314321	01314321	1
19	Strainer	0741410000601	0741410000601	0741410000601	2
20	Electronic Expansion Valve	07331139	07331139	07331139	1
21	Electric Expand Valve Fitting	4304413205	4304413205	4304413205	1
22	Evaporator Assy	01024100120	01024100120	01024100120	1
23	Filter Guide Groove	02284107	02284107	02284107	2
24	Filter Sub-Assy	11725211	11725211	11725211	2
25	Reactor	43130189	43130189	43130189	1
26	Terminal Board	4201800002601	4201800002601	4201800002601	1
27	Terminal Board	42010259	42010259	42010259	1
28	Main Board	30221000023	30221000023	30221000023	1
29	Main Board	30226000090	30226000090	30226000090	1
30	Radiator	49018000068	49018000068	49018000068	1
31	Top Cover Board Assy	01265359	01265359	01265359	1

Above data is subject to change without notice, pls reference the SP in global service website.

5.11 Slim Duct Type

Exploded View of GMV-ND22PL/B-T, GMV-ND25PL/B-T, GMV-ND28PL/B-T, GMV-ND32PL/B-T
GMV-ND36PL/B-T:

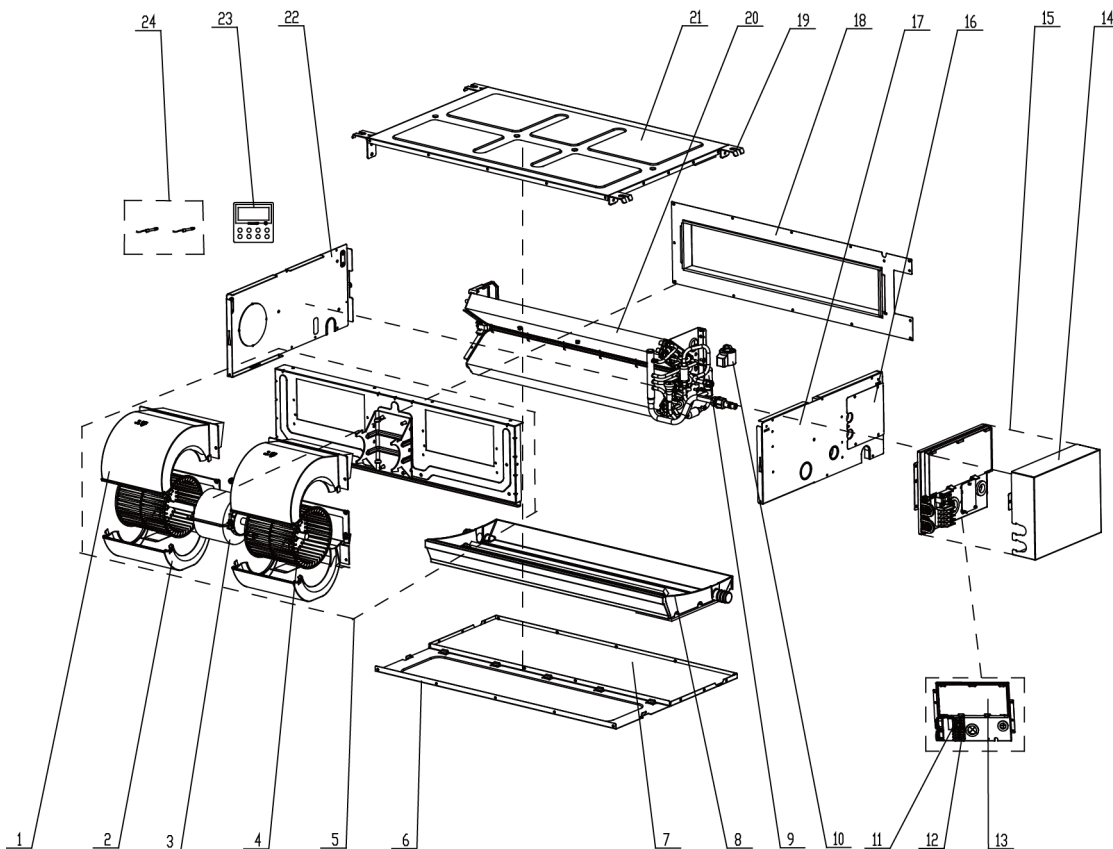

No.	Name of part	For the following unit	
		Unit	Product Code
		GMV-ND22PL/B-T	CM800N3560
		GMV-ND25PL/B-T	CM810N0010
		GMV-ND28PL/B-T	CM810N0020
		GMV-ND32PL/B-T	CM800N3570
		GMV-ND36PL/B-T	CM810N0030
		Part code	Quantity
1	Propeller Housing(Upper)	26905200018	2
2	Propeller Housing(Lower)	26905200019	2
3	Fan Motor	15704100001	1
4	Centrifugal Fan	10425200003	2
5	Centrifugal fan assy	15404100031	1
6	Cover Plate	01265200057	1
7	Bottom Cover Plate Assy	01265200065	1
8	Water Tray Assy	01285200020	1
9	Electronic Expansion Valve	07334463	1
10	Electric Expand Valve Fitting	4304413215	1
11	Terminal Board	42011106	1
12	Terminal Board	4201800002601	1
13	Main Board	30226000029	1
14	Electric Box Cover	01425200023	1
15	Electric Box Assy	01394100160	1
16	Closing Plate Sub-Assy	01494100010	1

No.	Name of part	For the following unit	
		Unit	Product Code
		GMV-ND22PL/B-T	CM800N3560
		GMV-ND25PL/B-T	CM810N0010
		GMV-ND28PL/B-T	CM810N0020
		GMV-ND32PL/B-T	CM800N3570
		GMV-ND36PL/B-T	CM810N0030
		Part code	Quantity
17	Left Side Plate Assy	01314100076	1
18	Air Outlet Frame Assy	01374100057	1
19	Hook	02112446	2
20	Hook	01344100034	2
21	Evaporator Assy	01024100039	1
22	Top Cover Board Assy	01265200066	1
23	Right Side Plate Assy	01315200053	1
24	Display Board	01315200053	1
25	Sensor Sub-assy	39004168G	1

Above data is subject to change without notice, pls reference the SP in global service website.

Exploded View of GMV-ND40PL/B-T, GMV-ND45PL/B-T, GMV-ND50PL/B-T, GMV-ND56PL/B-T, GMV-ND63PL/B-T:

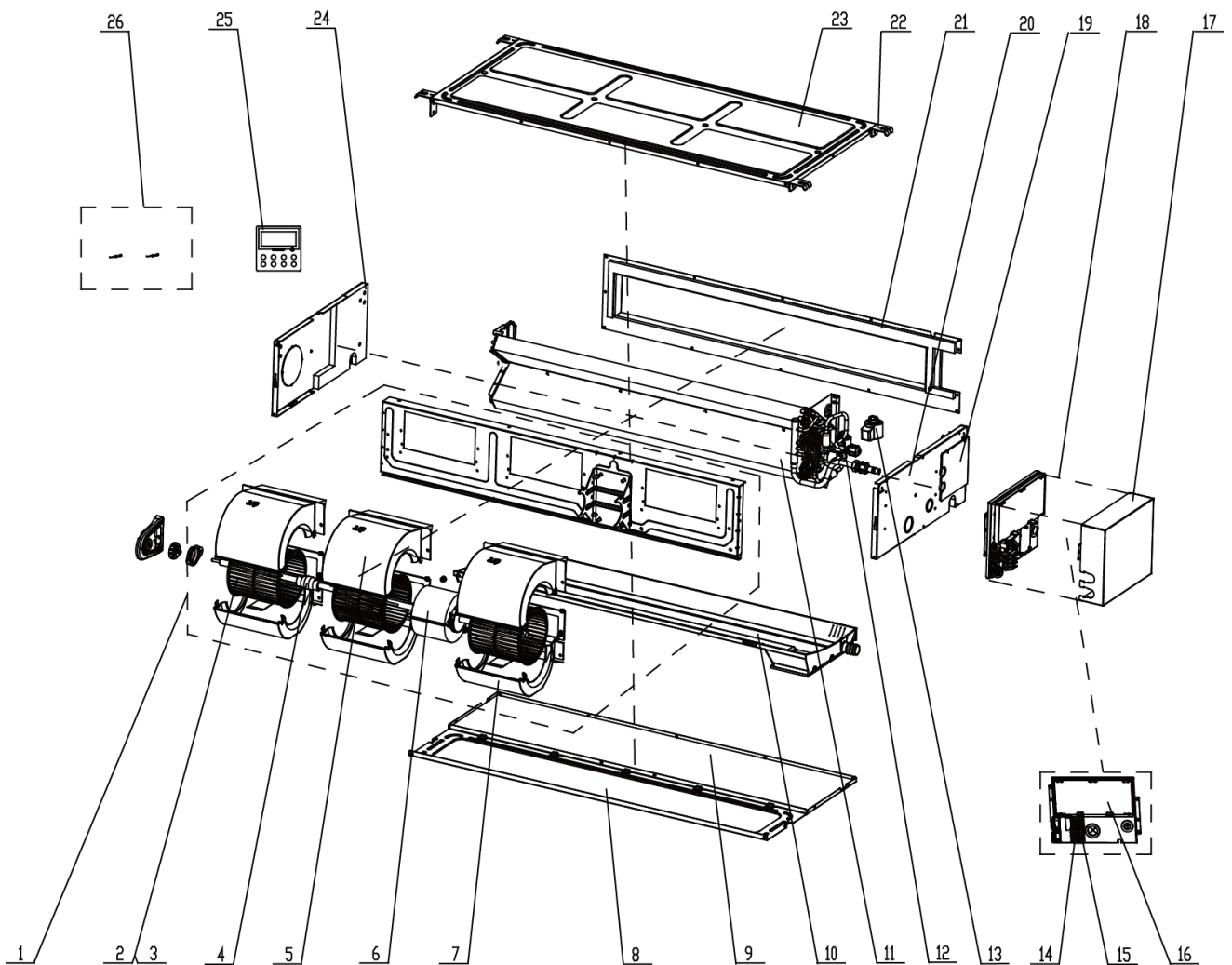

No.	Name of part	For the following unit	
		Unit	Product Code
		GMV-ND40PL/B-T	CM800N3580
		GMV-ND45PL/B-T	CM810N0040
		GMV-ND50PL/B-T	CM810N0050
		GMV-ND56PL/B-T	CM800N3590
		GMV-ND63PL/B-T	CM810N0060
		Part code	Quantity
1	Centrifugal fan assy	15404100032	1
2	Centrifugal Fan	10425200003	3
3	Fan Bearing	76512210	1
4	Joint Slack	73018731	1
5	Propeller Housing(Upper)	26905200018	3
6	Fan Motor	15704100001	1
7	Propeller Housing(Lower)	26905200019	3
8	Cover Of Air-in	01265200073	1
9	Bottom Cover Plate Assy	01265200071	1
10	Water Tray Assy	01285200022	1
11	Evaporator Assy	01024100042	1
12	Electronic Expansion Valve	07334466	1
13	Terminal Board	42011106	1
14	Terminal Board	4201800002601	1
15	Main Board	30226000029	1
16	Magnetic Ring	49010104	1
17	Electric Box Cover	01425200023	1
18	Electric Box Assy	01394100241	1
19	Closing Plate Sub-Assy	01494100010	1
20	Left Side Plate Assy	01314100076	1
21	Air Outlet Frame Assy	01374100058	1
22	Hook	02112446	2
23	Hook	01344100034	2
24	Top Cover Board Assy	01265200068	1
25	Right Side Plate Assy	01315200053	1
26	Display Board	30296000040	1
27	Sensor Sub-assy	39004168G	1

Above data is subject to change without notice, pls reference the SP in global service website.

Exploded View of GMV-ND72PL/B-T:

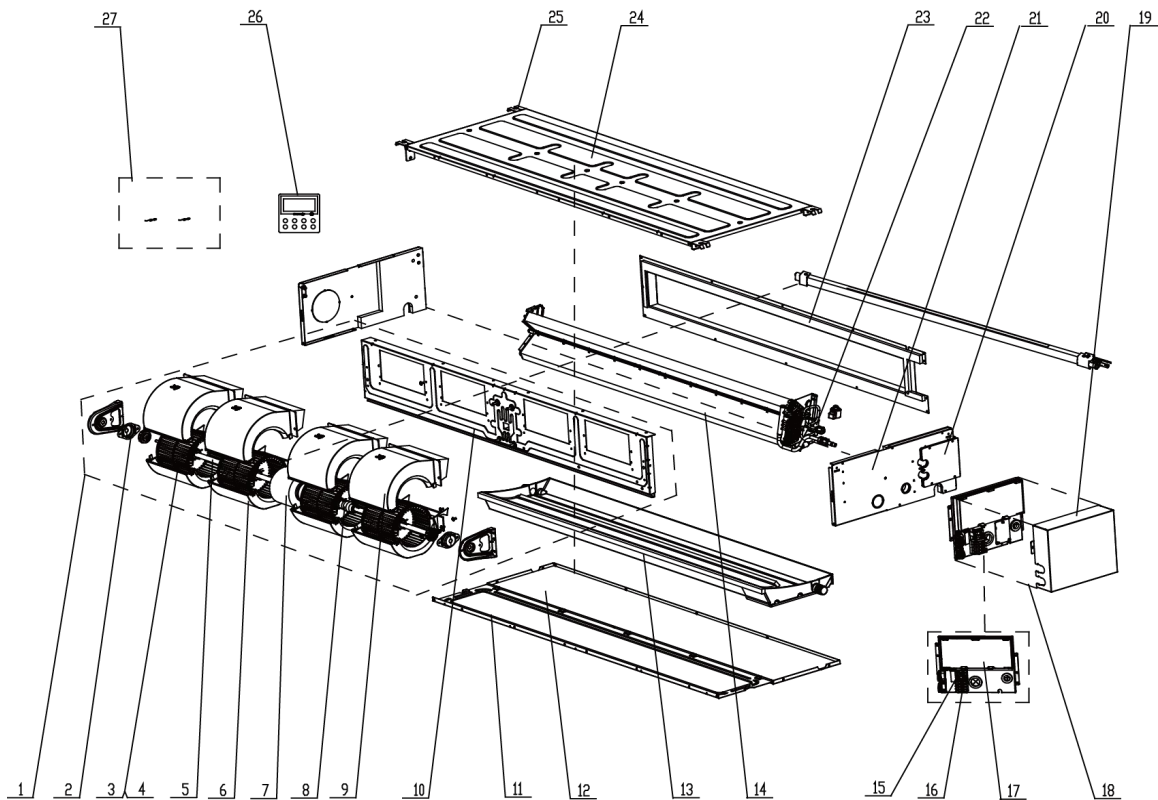

No.	Name of part	For the following unit	
		Unit	Product Code
		GMV-ND72PL/B-T	CM800N3600
		Part code	Quantity
1	Centrifugal fan assy	15404100032	1
2	Bearing Holder Sub-assy	26151139	2
3	Centrifugal Fan	10425200003	4
4	Fan Bearing	76512210	1
5	Rotary Axis Sub-Assy	73018761	2
6	Propeller Housing(Lower)	26905200019	4
7	DC brushless motor	15704100001	1
8	Joint Slack	73018731	2
9	Propeller Housing(Upper)	26905200018	4
10	Blower Mounting Plate Sub-Assy	01325200053	1
11	Cover Of Air-in	01265200085	1
12	Bottom Cover Plate Assy	01265200093	1
13	Water Tray Assy	01285200029	1
14	Evaporator Assy	01024100076	1
15	Terminal Board	42011106	1
16	Terminal Board	4201800002601	1
17	Main Board	30226000029	1
18	Electric Box Assy	01394100241	1
19	Electric Box Cover	01425200023	1
20	Closing Plate Sub-Assy	01494100010	1
21	Right Side Plate Assy	01315200053	1
22	Electronic Expansion Valve	07334466	1
23	Air Outlet Frame Assy	01374100059	1
24	Top Cover Board Assy	0126520009201	1

No.	Name of part	For the following unit	
		Unit	Product Code
		GMV-ND72PL/B-T	CM800N3600
		Part code	Quantity
25	Hook	02112446	2
26	Hook	01344100034	2
27	Display Board	30296000040	1
28	Sensor Sub-assy	39004168G	1

Above data is subject to change without notice, pls reference the SP in global service website.

Exploded View of GMV-ND22PLS/B1-T, GMV-ND25PLS/B1-T, GMV-ND28PLS/B1-T, GMV-ND32PLS/B1-T, GMV-ND36PLS/B1-T:

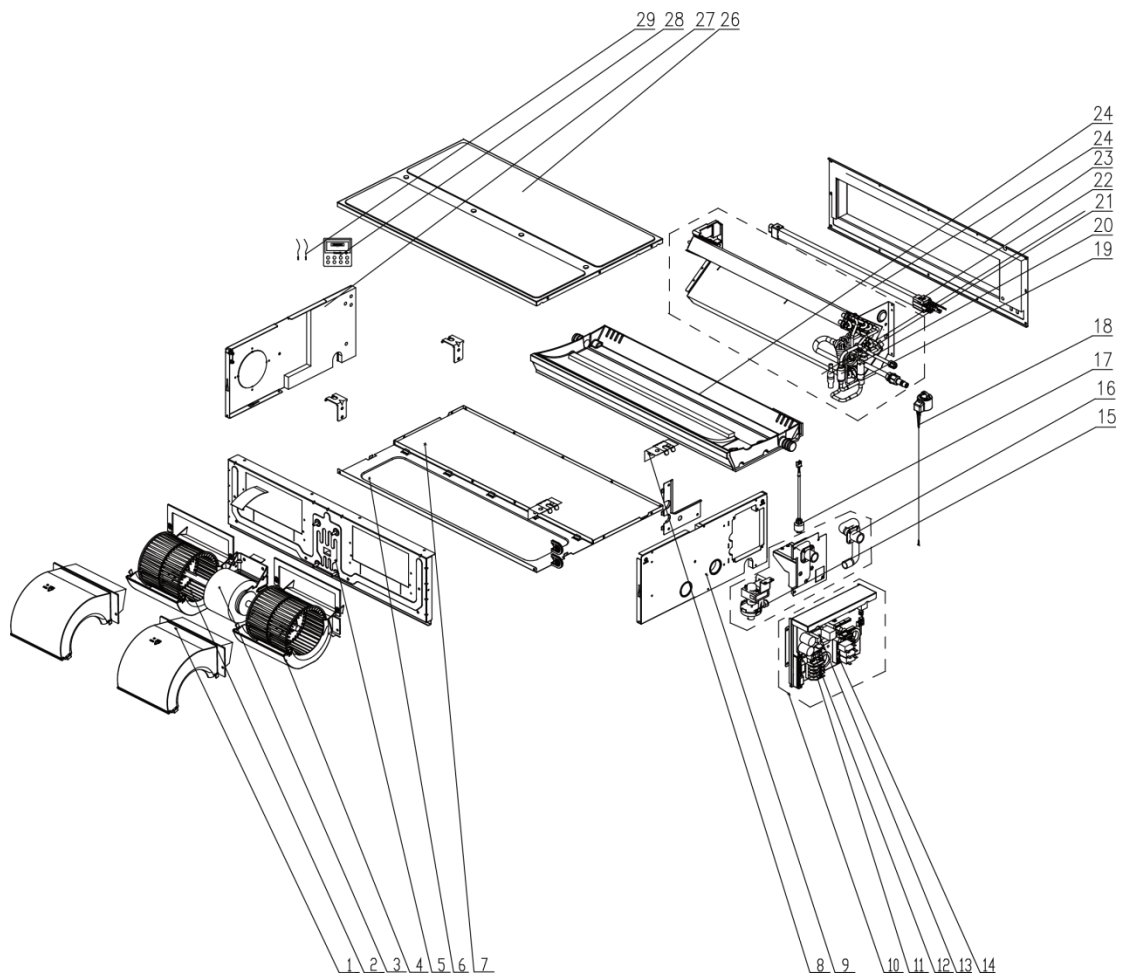

No.	Name of part	For the following unit	
		Unit	Product Code
		GMV-ND22SPL/B1-T	CM810N1580
		GMV-ND25SPL/B1-T	CM810N1570
		GMV-ND28SPL/B1-T	CM810N1340
		GMV-ND32SPL/B1-T	CM810N1560
		GMV-ND36SPL/B1-T	CM810N1330
Part code	Quantity		
1	Propeller Housing(Upper)	26905200018	2
2	Centrifugal Fan	10425200003	2
3	Brushless DC Motor	15704100001	1
4	Propeller Housing(Lower)	26905200019	2
5	Blower Mounting Plate Sub-Assy	01325200034	1

No.	Name of part	For the following unit	
		Unit	Product Code
		GMV-ND22SPL/B1-T	CM810N1580
		GMV-ND25SPL/B1-T	CM810N1570
		GMV-ND28SPL/B1-T	CM810N1340
		GMV-ND32SPL/B1-T	CM810N1560
		GMV-ND36SPL/B1-T	CM810N1330
		Part code	Quantity
6	Cover Plate(Air return)	01265200057	1
7	Bottom Cover Plate Assy	01264100102	1
8	Hook	02112446	2
9	Left Side Plate Assy	01314100136	1
10	Electric Box Assy	01394100602	1
11	Terminal Board	4201800002601	1
12	Terminal Board	42011106	1
13	Main Board	30226000029	1
14	Main Board 2	30227000010	1
15	Water Pump	4313822001	1
16	Pump Drainpipe	26904100172	1
17	Water Level Switch	4501270301	1
18	Electric Expand Valve Fitting	4304413215	1
19	Electronic Expansion Valve	07334463	1
20	Strainer	07213050	1
21	Strainer	0721200102	1
23	Air Outlet Frame Assy	01374100090	1
24	Evaporator Assy	01024100202	1
25	Water Tray Assy	01285200020	1
26	Top Cover Board Assy	01265200066	1
27	Right Side Plate Assy	01315200053	1
28	Sensor Sub-assy	39004168G	1
29	Display Board	30296000026	1

Above data is subject to change without notice, pls reference the SP in global service website.

Exploded View of GMV-ND40PLS/B1-T, GMV-ND45PLS/B1-T, GMV-ND50PLS/B1-T,
GMV-ND56PLS/B1-T, GMV-ND63PLS/B1-T:

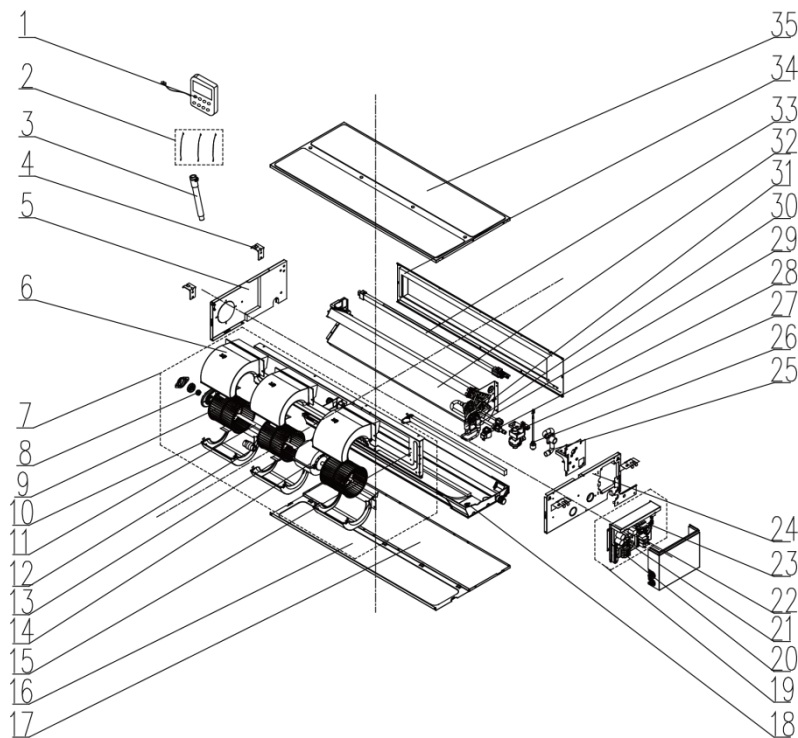

No.	Name of part	For the following unit	
		Unit	Product Code
		GMV-ND40SPL/B1-T	CM810N1550
		GMV-ND45SPL/B1-T	CM810N1350
		GMV-ND50SPL/B1-T	CM810N1540
		GMV-ND56SPL/B1-T	CM810N1530
		GMV-ND63SPL/B1-T	CM810N1360
1	Display Board	300001000054	1
2	Sensor Sub-Assy	390002000005	1
4	Hook	2112446	2
5	Right Side Plate Assy	1315200053	1
6	Propeller Housing(Upper)	26905200018	3
7	Centrifugal Fan Assy	15404100032	1
8	Fan Bearing	76512210	1
9	Centrifugal Fan	10425200003	3
10	Propeller Housing(Lower)	26905200019	3
11	Rotary Axis Sub-Assy	73018761	1
12	Joint Slack	73018731	1
13	Motor Support	1805200144	1
14	Brushless DC Motor	1570410000102	1
15	Blower Mounting Plate Sub-Assy	1325200035	1
16	Cover Of Air-In	1265200073	1
17	Bottom Cover Plate Assy	1264100103	1
18	Water Tray Assy	1285200022	1
19	Electric Box Assy	1394100615	1
20	Terminal Board	42011106	1
21	Terminal Board	4201800002601	1
23	Main Board	30226000029	1
24	Left Side Plate Assy	1314100136	1

No.	Name of part	For the following unit	
		Unit	Product Code
		GMV-ND40SPL/B1-T	CM810N1550
		GMV-ND45SPL/B1-T	CM810N1350
		GMV-ND50SPL/B1-T	CM810N1540
		GMV-ND56SPL/B1-T	CM810N1530
		GMV-ND63SPL/B1-T	CM810N1360
25	Drain Hose Sub-Assy	5232050	1
26	Water Level Switch	4501270303	1
27	Water Pump	4313822002	1
28	Electric Expand Valve Fitting	4304413253	1
29	Electronic Expansion Valve	7334466	1
30	Strainer	721200102	1
31	Strainer	7213050	1
32	Evaporator Assy	1024100211	1
34	Air Outlet Frame Assy	1374100091	1
35	Top Cover Board Assy	1265200068	1

Above data is subject to change without notice, pls reference the SP in global service website.

Exploded View of GMV-ND71PLS/B1-T:

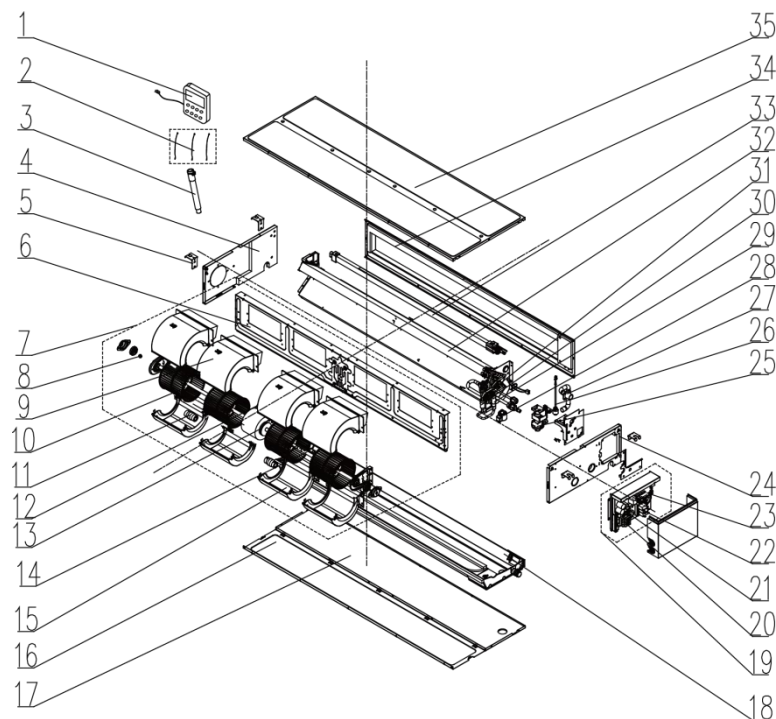

No.	Name of part	For the following unit	
		Unit	Product Code
		GMV-ND40SPL/B1-T	CM810N1550
1	Display Board	30296000026	1
2	Sensor Sub-Assy	39004168G	1
3	Corrugated Pipe	05010051	1
4	Right Side Plate Assy	01315200053	1
5	Hook	02112446	2
6	Blower Mounting Plate Sub-Assy	01325200053	1
7	Centrifugal fan assy	15404100038	1
8	Fan Bearing	76512210	1
9	Propeller Housing(Upper)	26905200018	4

No.	Name of part	For the following unit	
		Unit	Product Code
		GMV-ND40SPL/B1-T	CM810N1550
10	Centrifugal Fan	10425200003	4
11	Joint Slack	73018731	2
12	Motor Support	01805200144	1
13	Brushless DC Motor	15704100001	1
14	Rotary Axis Sub-Assy	73018761	2
15	Propeller Housing(Lower)	26905200019	4
16	Cover Of Air-In	01265200085	1
17	Bottom Cover Plate Assy	01264100104	1
18	Water Tray Assy	01285200029	1
19	Electric Box Assy	01394100602	1
20	Terminal Board	4201800002601	1
21	Terminal Board	42011106	1
22	Main Board 2	30227000010	1
23	Main Board	30226000029	1
24	Left Side Plate Assy	01314100136	1
25	Water Pump	4313822001	1
26	Water Level Switch	4501270301	1
27	Drain Hose Sub-Assy	05232050	1
28	Electric Expand Valve Fitting	4304413215	1
29	Electronic Expansion Valve	07334466	1
30	Strainer	07213050	1
31	Strainer	0721200102	1
32	Evaporator Assy	01024100197	1
34	Air Outlet Frame Assy	01374100092	1
35	Top Cover Board Assy	01265200092	1

Above data is subject to change without notice, pls reference the SP in global service website.

5.12 Console Type Indoor Unit

Exploded View of GMV-ND22C/A-T, GMV-ND28C/A-T, GMV-ND36C/A-T, GMV-ND45C/A-T, GMV-ND50C/A-T:

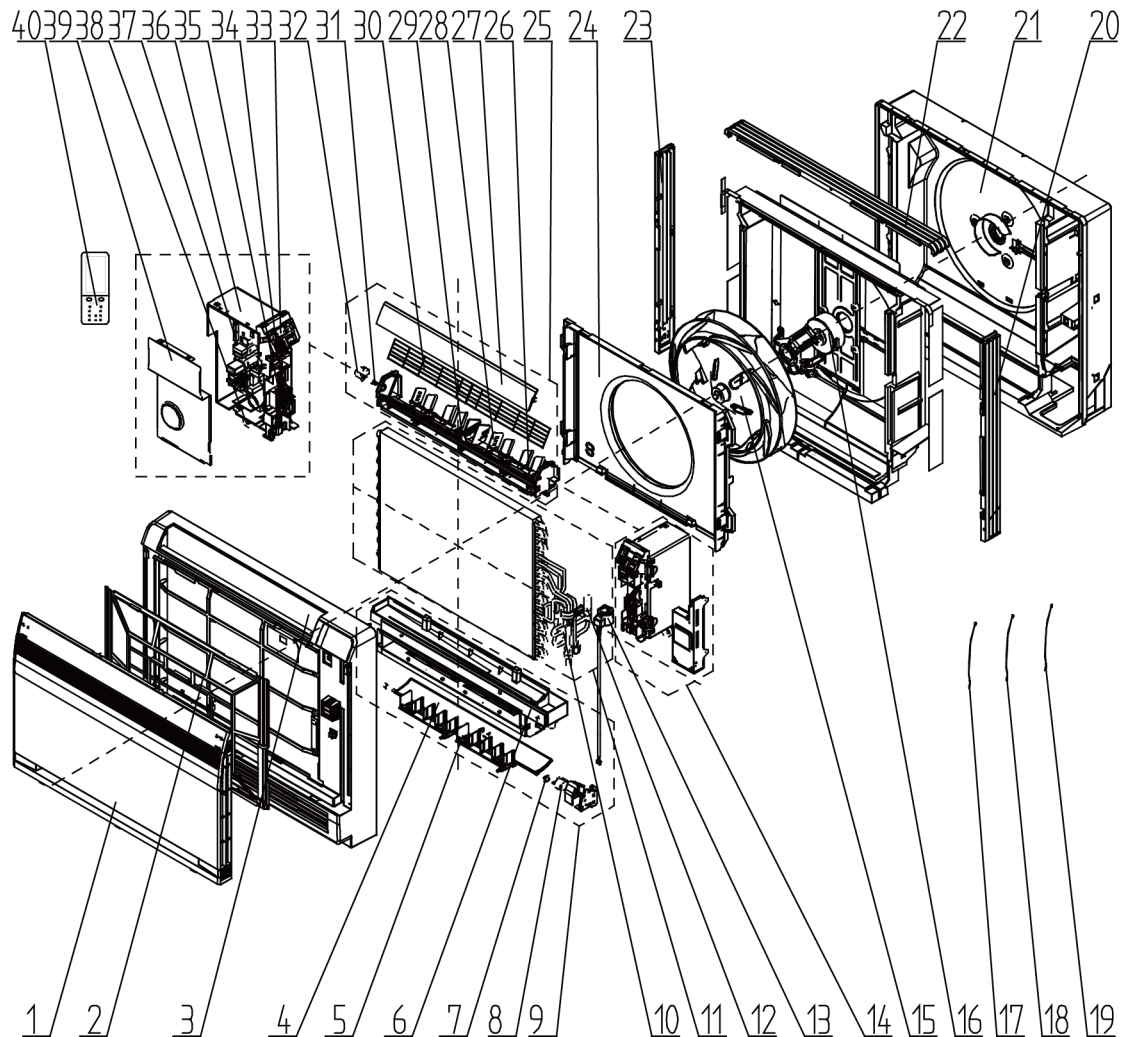

No.	Name of part	For the following unit	
		Unit	Product Code
		GMV-ND22C/A-T	CM400N0140
		GMV-ND28C/A-T	CM400N0070
		GMV-ND36C/A-T	CM400N0080
		GMV-ND45C/A-T	CM400N0150
		GMV-ND50C/A-T	CM400N0090
		Part code	Quantity
1	Front Panel Assy	20012756	1
2	Filter Sub-Assy	11122139	1
3	Front Case Assy	20012601	1
4	Air Louver(lower)	10512146	1
5	Air Louver(lower)	10512144	2
6	Water Tray	20182140	1
7	Axis(lower step motor)	10542034	1
8	Stepping Motor	1521210101	1
9	Water Tray Assy	20182141	1
10	Strainer	7213029	1

No.	Name of part	For the following unit	
		Unit	Product Code
		GMV-ND22C/A-T	CM400N0140
		GMV-ND28C/A-T	CM400N0070
		GMV-ND36C/A-T	CM400N0080
		GMV-ND45C/A-T	CM400N0150
		GMV-ND50C/A-T	CM400N0090
		Part code	Quantity
11	Evaporator Assy	1024100143	1
12	Electronic Expansion Valve	7334282	1
13	Electric Expand Valve Fitting	4304000102	1
14	Electric Box Assy	1394100489	1
15	Centrifugal Fan	1394100489	1
16	Brushless DC Motor	15704100012	1
17	Temperature Sensor	3900005910	1
18	Temperature Sensor	390000597	1
19	Temperature Sensor	3900019824	1
20	Let Side Plate	20052011	1
21	Rear Case	22202461	1
22	Top Side Plate	20052013	1
23	Right Side Plate	20052012	1
24	Diversion Circle	10371212	1
25	Louver Motor Sub-assy	21100001	1
26	Swing Lever	10582096	2
27	Guide Louver (upper)	10512145	1
28	Air Louver(upper)	10512143	2
29	Shaft of Guide Louver	10542020	2
30	Rear Grill	1472024	1
31	Crank	73012005	1
32	Stepping Motor	1521210101	1
33	Display Board	30568131	1
34	Pinboard	30278000001	1
35	Terminal Board	42010268	1
36	Electric Board	20112116	1
37	Main Board	30226000080	1
38	Magnetic Ring	49010104	1
39	Shield Cover of Electric Box Sub-assy	01592169	1
40	Remote Controller	30510589	1

Above data is subject to change without notice, pls reference the SP in global service website.

5.13 Wall Mounted type Indoor Unit

Exploded View of GMV-N22G/A3A-K, GMV-N28G/A3A-K:

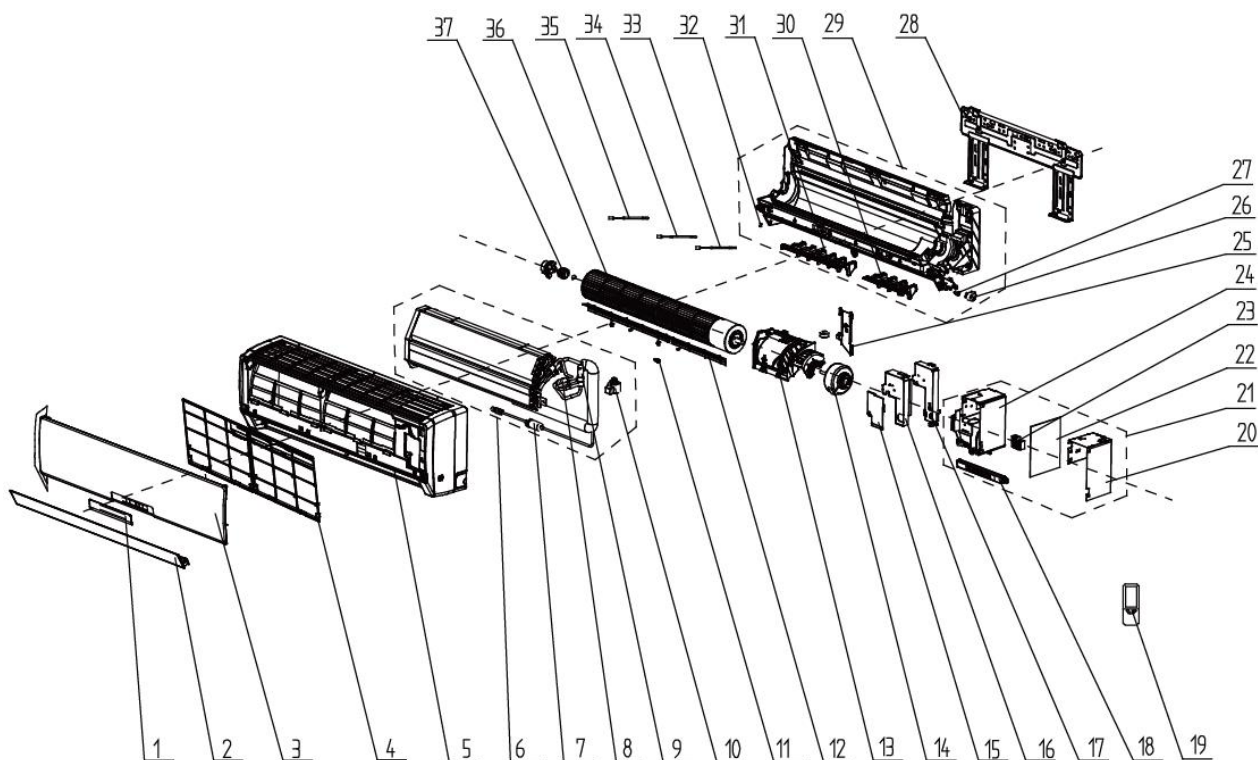

No.	Name of part	For the following unit	
		Unit	Product Code
		GMV-N22G/A3A-K	CM100N1350
		GMV-N28G/A3A-K	CM100N1340
		Part code	Quantity
1	Receiver Window	22432230	1
2	Guide Louver	10512157	1
3	Front Panel B1	20012122S	1
4	Filter Sub-Assy	1112220403	1
5	Front Case Sub-assy	2001213931	1
6	Evaporator Assy	1024100097	2
7	Strainer	07414100006	4
8	Strainer	07213050	4
9	Electronic Expansion Valve	07334463	4
10	Electric Expand Valve Fitting	4304413217	2
11	Axile Bush	10542036	1
12	Rear Grill	01472013	1
13	Motor Press Plate	26904100117	1
14	Fan Motor	1501208905	1
15	Electric Box Cover2	2012207504	1
16	Shield Cover of Electric Box Sub-assy	01592073	1
17	Electric Box Cover1	2224213502	1
18	Display Board	30565007	2
19	Remote Controller	30510589	1
20	Lower Shield Sub-assy of Electric Box	01592072	2
21	Electric Box Assy	01394100451	1
22	Main Board	30226000061	2

No.	Name of part	For the following unit	
		Unit	Product Code
		GMV-N22G/A3A-K	CM100N1350
		GMV-N28G/A3A-K	CM100N1340
		Part code	Quantity
23	Terminal Board	42010268	2
24	Electric Box	2011216702	2
25	Connecting pipe clamp	26112164	1
26	Stepping Motor	1521212901	2
27	Crank	10582070	2
28	Wall Mounting Frame	01252021	1
29	Rear Case Sub-Assy	2220294712	2
30	Air Louver 1	10512164	2
31	Air Louver 2	10512165	2
32	Left Axile Bush	10512037	2
33	Temperature Sensor	390000454	1
34	Temperature Sensor	39000076G	1
35	Temperature Sensor	390002072G	1
36	Cross Flow Fan	10454101	1
37	O-Gasket of Cross Fan Bearing	76512203	3

Above data is subject to change without notice, pls reference the SP in global service website.

GMV-N36G/A3A-K, GMV-N45G/A3A-K, GMV-N50G/A3A-K:

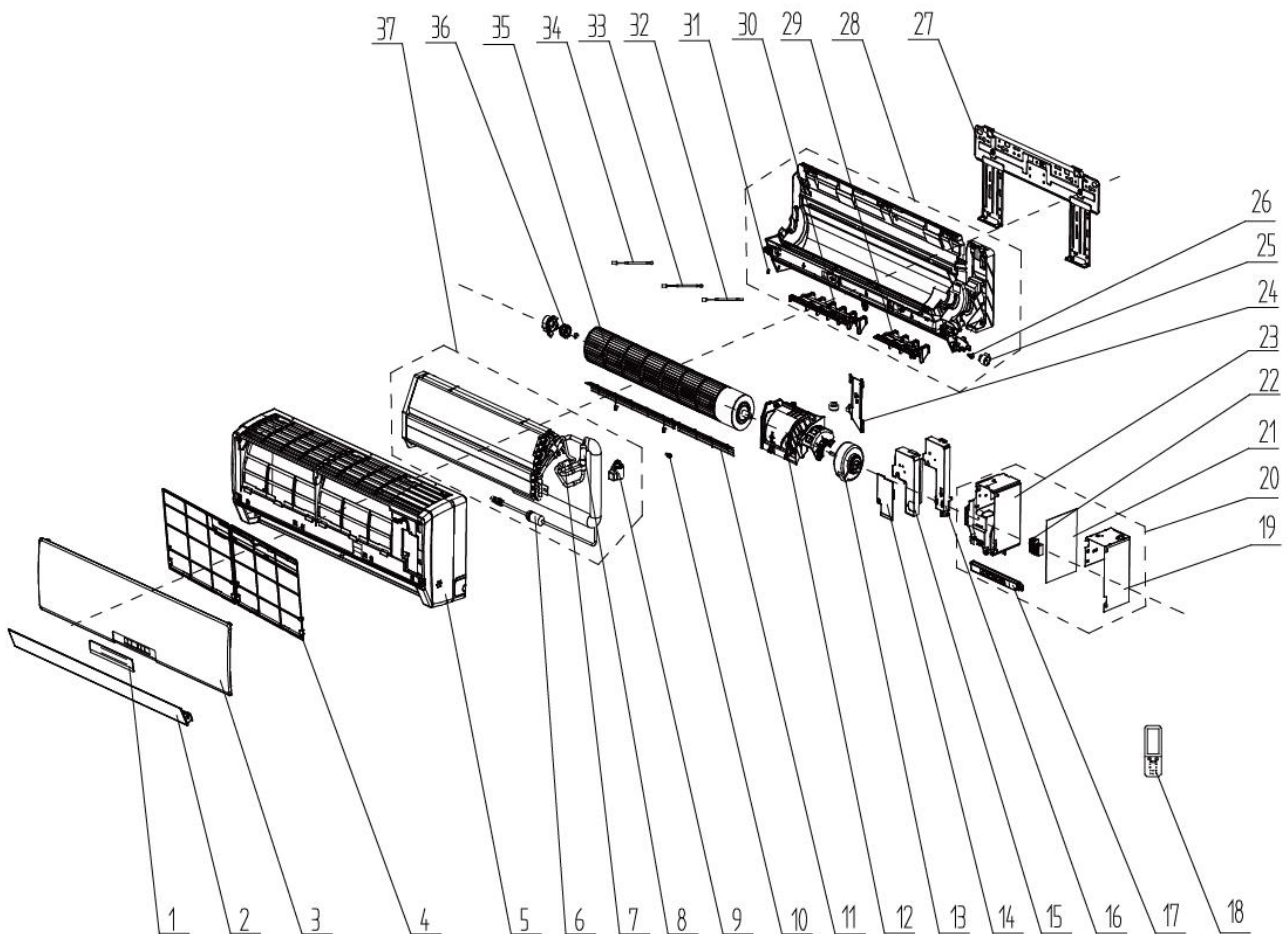

No.	Name of part	For the following unit	
		Unit	Product Code
		GMV-N36G/A3A-K	CM100N1360
		GMV-N45G/A3A-K	CM100N1370
		GMV-N50G/A3A-K	CM100N1330
		Part code	Quantity
1	Receiver Window	22432173	1
2	Guide Louver	10512115	1
3	Front Panel Assy	20012260	1
4	Filter Sub-Assy	1112000000	2
5	Front Case Sub-assy	20022172	1
6	Strainer	07414100006	1
7	Strainer	7213050	1
8	Electronic Expansion Valve	7334466	1
9	Electric Expand Valve Fitting	4304000000	1
10	Axile Bush	10542036	1
11	Mesh Enclosure(Air Outlet)	1472015	1
12	Motor Press Plate	26904264	1
13	Fan Motor	1501000000	1
14	Electric Box Cover	2011000000	1
15	Shield Cover of Electric Box	1592092	1
16	Electric Box Cover1	2012000000	1
17	Display Board	30565038	1
18	Remote Controller	30510589	1
19	Lower Shield of Electric Box	1592091	1
20	Electric Box Assy	1394000000	1
21	Main Board	30230000000	1
22	Terminal Board	42010268	1
23	Electric Box	2011000000	1
24	Connecting pipe clamp	26112164	1
25	SteppingMotor	15012086	1
26	Crank	10582070	1
27	Wall Mounting Frame	1252218	1
28	Rear Case Sub-Assy	2220000000	1
29	Air Louver 1	10512708	1
30	Air Louver 2	10512709	1
31	Left Axile Bush	10512037	1
32	Temperature Sensor	39000076G	1
33	Temperature Sensor	390000454	1
34	Temperature Sensor	390002072G	1
35	Cross Flow Fan	10454102	1
36	O-Gasket of Cross Fan Bearing	76512203	1
37	Evaporator Assy	01024100101	1

Above data is subject to change without notice, pls reference the SP in global service website.

GMV-N56G/A3A-K, GMV-N63G/A3A-K, GMV-N71G/A3A-K:

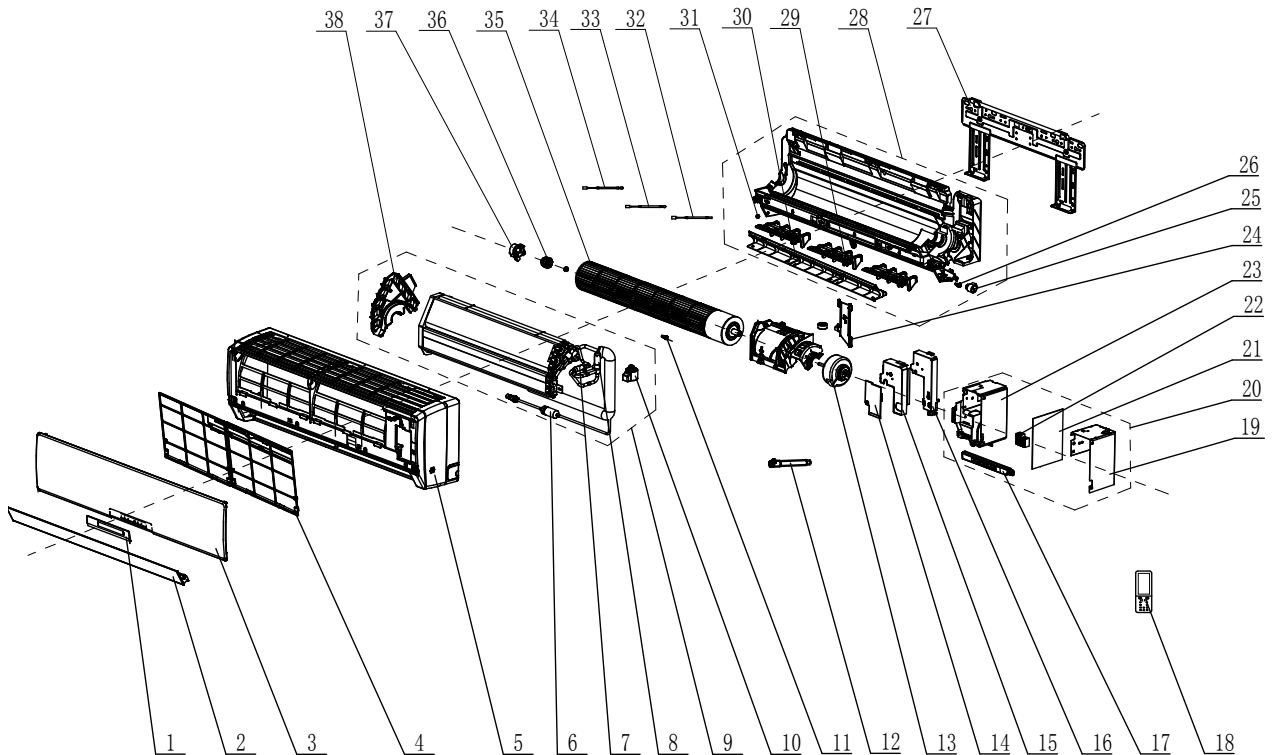

No.	Name of part	For the following unit	
		Unit	Product Code
		GMV-N56G/A3A-K	CM100N1380
		GMV-N63G/A3A-K	CM100N1390
		GMV-N71G/A3A-K	CM100N1320
		Part code	Quantity
1	Receiver Window	22432230	1
2	Guide Louver	10512157	1
3	Front Panel B1	20012122S	1
4	Filter Sub-Assy	1112220403	1
5	Front Case Sub-assy	2001213931	1
6	Evaporator Assy	1024100097	2
7	Strainer	07414100006	4
8	Strainer	07213050	4
9	Electronic Expansion Valve	07334463	4
10	Electric Expand Valve Fitting	4304413217	2
11	Axile Bush	10542036	1
12	Rear Grill	01472013	1
13	Motor Press Plate	26904100117	1
14	Fan Motor	1501208905	1
15	Electric Box Cover2	2012207504	1
16	Shield Cover of Electric Box Sub-assy	01592073	1
17	Electric Box Cover1	2224213502	1
18	Display Board	30565007	2
19	Remote Controller	30510589	1
20	Lower Shield Sub-assy of Electric Box	01592072	2
21	Electric Box Assy	01394100451	1
22	Main Board	30226000061	2
23	Terminal Board	42010268	2

No.	Name of part	For the following unit	
		Unit	Product Code
		GMV-N56G/A3A-K	CM100N1380
		GMV-N63G/A3A-K	CM100N1390
		GMV-N71G/A3A-K	CM100N1320
	Part code	Quantity	
24	Electric Box	2011216702	2
25	Connecting pipe clamp	26112164	1
26	Stepping Motor	1521212901	2
27	Crank	10582070	2
28	Wall Mounting Frame	01252021	1
29	Rear Case Sub-Assy	2220294712	2
30	Air Louver 1	10512164	2
31	Air Louver 2	10512165	2
32	Left Axile Bush	10512037	2
33	Temperature Sensor	390000454	1
34	Temperature Sensor	39000076G	1
35	Temperature Sensor	390002072G	1
36	Cross Flow Fan	10454101	1
37	O-Gasket of Cross Fan Bearing	76512203	3

Above data is subject to change without notice, pls reference the SP in global service website.

Exploded View of GMV-ND22G/A3A-T、GMV-ND28G/A3A-T:

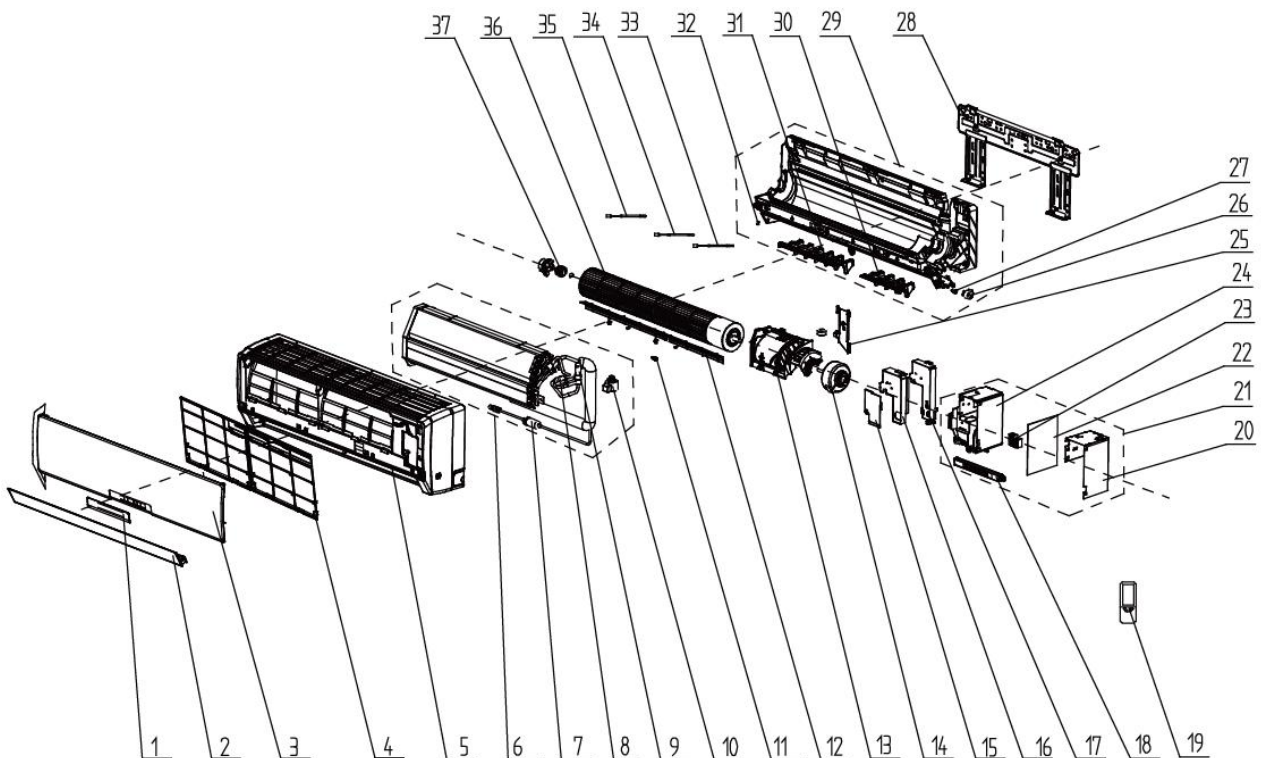

No.	Name of part	For the following unit	
		Unit	Product Code
		GMV-ND22G/A3A-T	CM100N2560
		GMV-ND28G/A3A-T	CM100N2600
	Part code	Quantity	

1	Receiver Window	22432230	1
2	Guide Louver	10512157	1
3	Front Panel A3	20012123C	1
4	Filter Sub-Assy	1112220403	1
5	Front Case Sub-assy	2001213931	1
6	Evaporator Assy	01024100097	.2
7	Strainer	07414100006	..4
8	Strainer	07213050	..4
9	Electronic Expansion Valve	07334463	..4
10	Electric Expand Valve Fitting	4304413217	.2
11	Axile Bush	10542036	1
12	Rear Grill	01472013	1
13	Motor Press Plate	26904100117	1
14	Fan Motor	1501306804	1
15	Electric Box Cover2	2012207504	1
16	Shield Cover of Electric Box Sub-assy	01592073	1
17	Electric Box Cover1	2224213502	1
18	Display Board	30565007	.2
19	Remote Controller	30510589	1
20	Lower Shield Sub-assy of Electric Box	01592072	.2
21	Electric Box Assy	01394100451	1
22	Main Board	300002000702	.2
23	Terminal Board	42010268	.2
24	Electric Box	2011216702	.2
25	Connecting pipe clamp	26112164	1
26	Stepping Motor	1521212901	.2
27	Crank	10582070	.2
28	Wall Mounting Frame	01252021	1
29	Rear Case Sub-Assy	2220294712	.2
30	Air Louver 1	10512164	.2
31	Air Louver 2	10512165	.2
32	Left Axile Bush	10512037	.2
33	Temperature Sensor	390000454	1
34	Temperature Sensor	39000076G	1
35	Temperature Sensor	390002072G	1
36	Cross Flow Fan	10454101	1
37	O-Gasket of Cross Fan Bearing	76512203	..3

Above data is subject to change without notice, pls reference the SP in global service website.

Exploded View of GMV-ND36G/A3A-T、GMV-ND45G/A3A-T、GMV-ND50G/A3A-T:

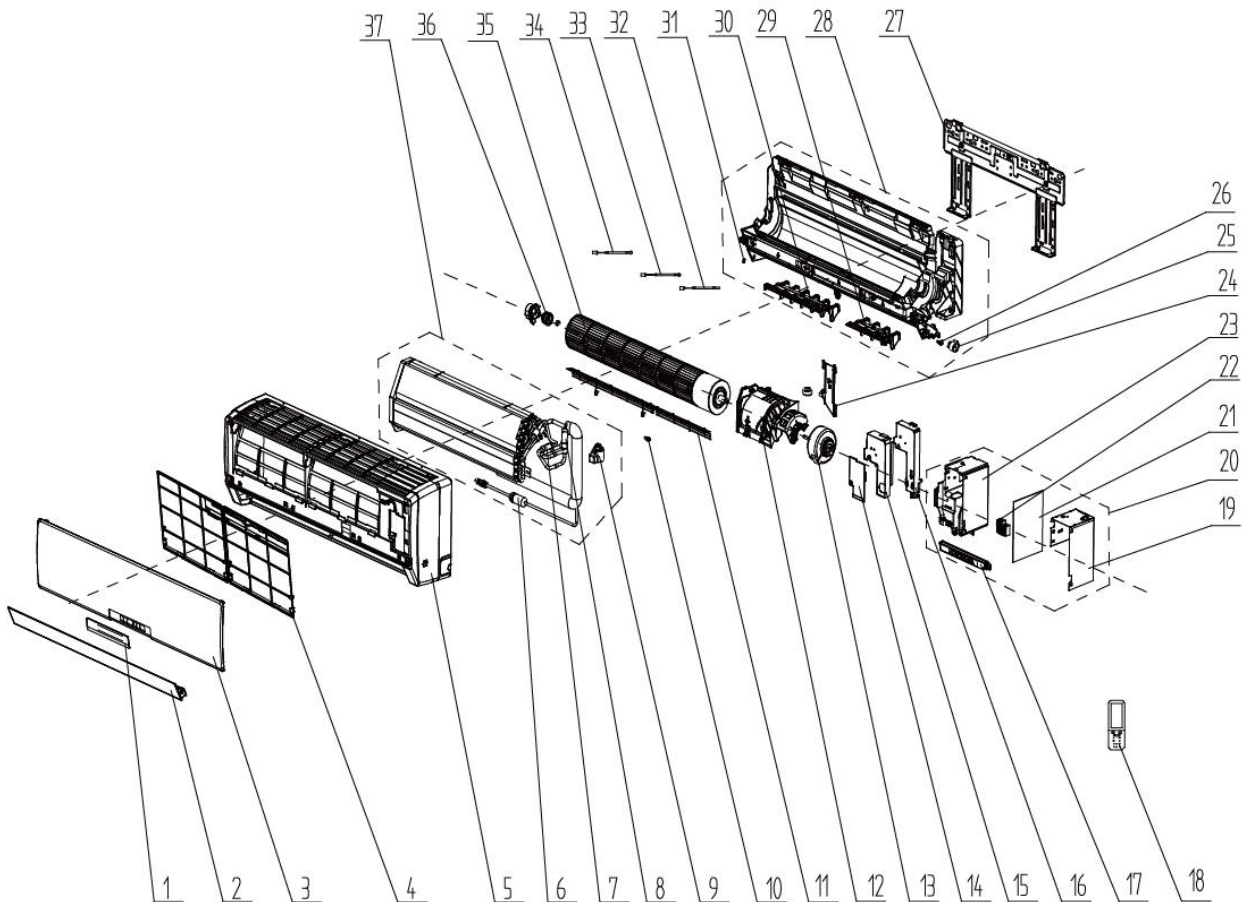

No.	Name of part	For the following unit	
		Unit	Product Code
		GMV-ND36G/A3A-T	CM100N2590
		GMV-ND45G/A3A-T	CM100N2580
		GMV-ND50G/A3A-T	CM100N2610
		Part code	Quantity
1	Receiver Window	22432173	1
2	Guide Louver	10512115	1
3	Front Panel Assy	20022146	1
4	Filter Sub-Assy	1112000000	2
5	Front Case Sub-assy	20022172	1
6	Strainer	07414100006	1
7	Strainer	7213050	1
8	Electronic Expansion Valve	7334466	1
9	Electric Expand Valve Fitting	4304000000	1
10	Axile Bush	10542036	1
11	Mesh Enclosure(Air Outlet)	1472015	1
12	Motor Press Plate	26904264	1
13	Fan Motor	1501246601	1
14	Electric Box Cover	2011000000	1
15	Shield Cover of Electric Box	1592092	1

No.	Name of part	For the following unit	
		Unit	Product Code
		GMV-ND36G/A3A-T	CM100N2590
		GMV-ND45G/A3A-T	CM100N2580
		GMV-ND50G/A3A-T	CM100N2610
	Part code	Quantity	
16	Electric Box Cover1	2012000000	1
17	Display Board	30565038	1
18	Remote Controller	30510589	1
19	Lower Shield of Electric Box	1592091	1
20	Electric Box Assy	1394000000	1
21	Main Board	300002000703	1
22	Terminal Board	42010268	1
23	Electric Box	2011000000	1
24	Connecting pipe clamp	26112164	1
25	Stepping Motor	15012086	1
26	Crank	10582070	1
27	Wall Mounting Frame	1252218	1
28	Rear Case Sub-Assy	2220000000	1
29	Air Louver 1	10512708	1
30	Air Louver 2	10512709	1
31	Left Axile Bush	10512037	1
32	Temperature Sensor	39000076G	1
33	Temperature Sensor	390000454	1
34	Temperature Sensor	390002072G	1
35	Cross Flow Fan	10454102	1
36	O-Gasket of Cross Fan Bearing	76512203	1
37	Evaporator Assy	01024100101	1

Above data is subject to change without notice, pls reference the SP in global service website.

Exploded View of GMV-ND56G/A3A-T、GMV-ND63G/A3A-T、GMV-ND71G/A3A-T:

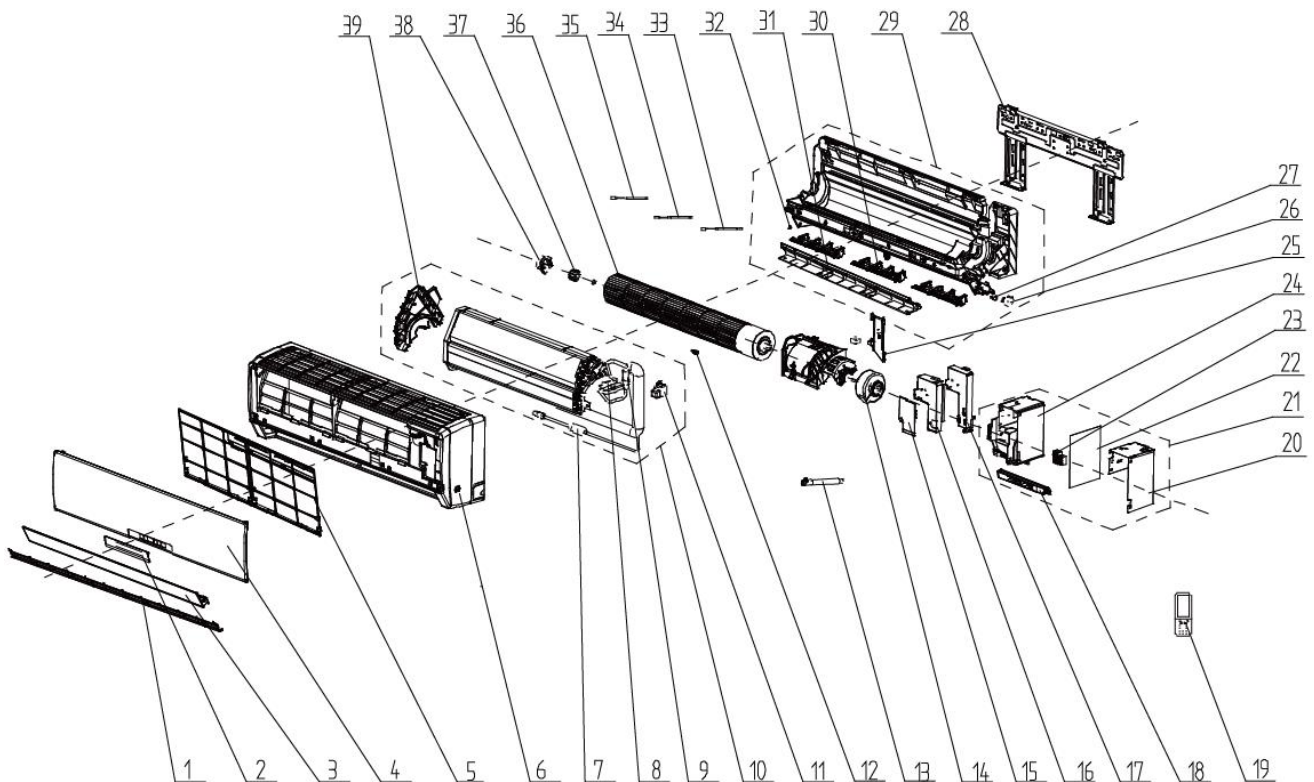

No.	Name of part	For the following unit	
		Unit	Product Code
		GMV-ND56G/A3A-T	CM100N2570
		GMV-ND63G/A3A-T	CM100N2550
		GMV-ND71G/A3A-T	CM100N2540
		Part code	Quantity
1	Receiver Window	22432230	1
2	Guide Louver	10512157	1
3	Front Panel A3	20012295	1
4	Filter Sub-Assy	1112220403	1
5	Front Case Sub-assy	2001213931	1
6	Evaporator Assy	01024100097	.2
7	Strainer	07414100006	..4
8	Strainer	07213050	..4
9	Electronic Expansion Valve	07334463	..4
10	Electric Expand Valve Fitting	4304413217	.2
11	Axile Bush	10542036	1
12	Rear Grill	01472013	1
13	Motor Press Plate	26904100117	1
14	Fan Motor	1501208905	1
15	Electric Box Cover2	2012207504	1
16	Shield Cover of Electric Box Sub-assy	01592073	1
17	Electric Box Cover1	2224213502	1
18	Display Board	30565007	.2
19	Remote Controller	30510589	1

20	Lower Shield Sub-assy of Electric Box	01592072	.2
21	Electric Box Assy	01394100451	1
22	Main Board	300002000703	.2
23	Terminal Board	42010268	.2
24	Electric Box	2011216702	.2
25	Connecting pipe clamp	26112164	1
26	Stepping Motor	1521212901	.2
27	Crank	10582070	.2
28	Wall Mounting Frame	01252021	1
29	Rear Case Sub-Assy	2220294712	.2
30	Air Louver 1	10512164	.2
31	Air Louver 2	10512165	.2
32	Left Axile Bush	10512037	.2
33	Temperature Sensor	390000454	1
34	Temperature Sensor	39000076G	1
35	Temperature Sensor	390002072G	1
36	Cross Flow Fan	10454101	1
37	O-Gasket of Cross Fan Bearing	76512203	.3

Above data is subject to change without notice, pls reference the SP in global service website.

Exploded View of GMV-ND80G/A3A-T 、 GMV-ND90G/A3A-T 、 GMV-ND100G/A3A-T 、
GMV-ND80G/B4B-T、GMV-ND90G/B4B-T、GMV-ND100G/B4B-T:

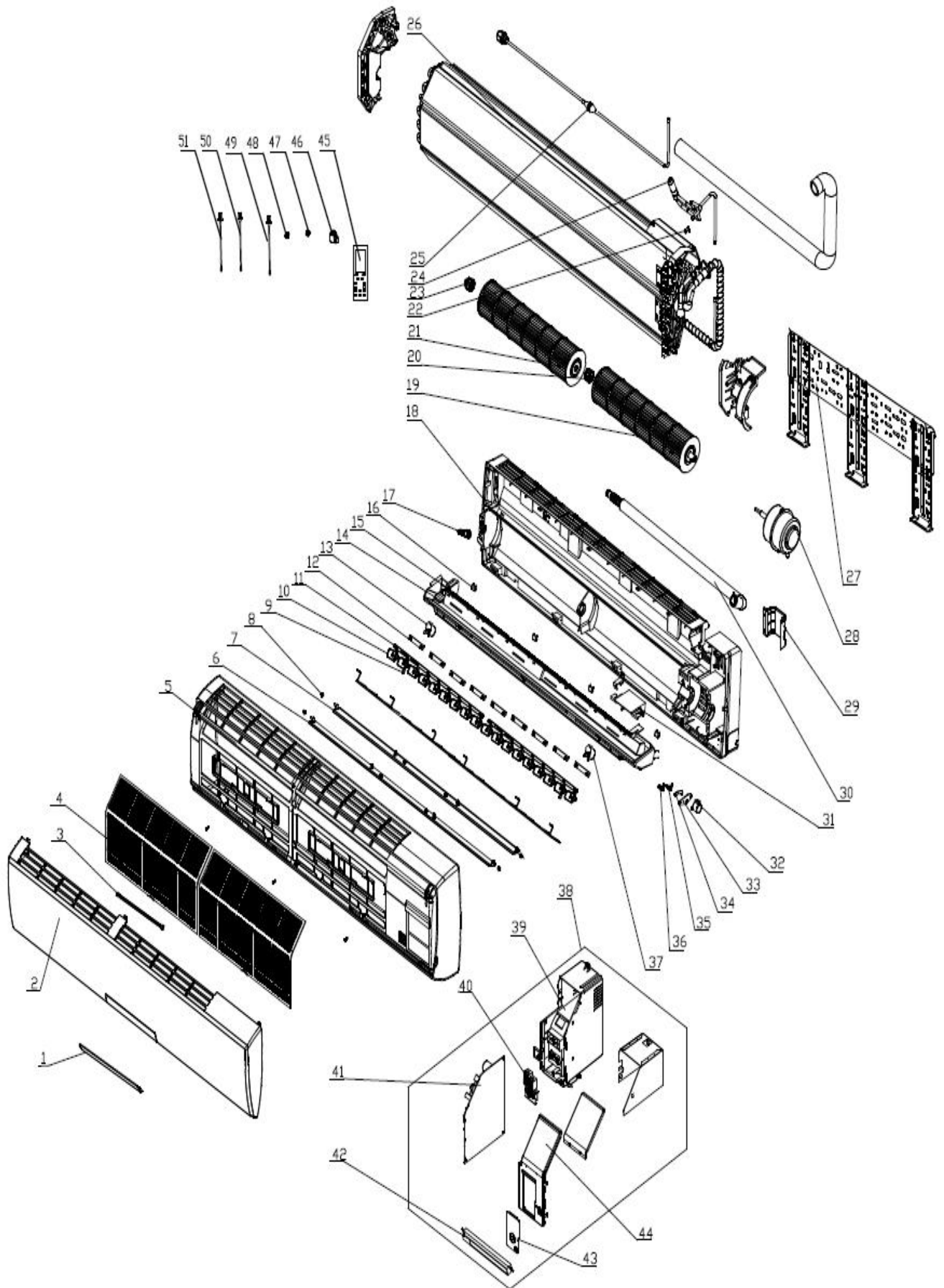

No.	Name of part	For the following unit	
		Unit	Product Code
		GMV-ND80G/A3A-T	CM100N2620
		GMV-ND90G/A3A-T	CM100N2630
		GMV-ND100G/A3A-T	CM100N2640
		Part code	Quantity
1	Receiver Window	22432164	1
2	Front Panel	20012490S	1
3	Stand Bar	24212120	1
4	Filter Sub-Assy	11122106	2
5	Front Case Sub-assy	209007000027	1
6	Upper Guide Louver	10512166	1
7	Lower Guide Louver	10512167	1
8	Axile Bush	10542704	6
9	Air Louver 2	10512169	2
10	Air Louver 1	10512168	16
11	Connecting Rod	10582086	2
12	Louver Clamp	26112127	9
13	Stepping Motor	1521210701	1
14	Water Tray	20182138	1
15	Air Guider System in Water Tray Assy	10102040	1
16	Screw Cover	242520053	4
17	Rubber Plug (Water Tray)	76712012	1
18	Rear Case Sub-Assy	22202703	1
19	Cross Flow Fan 1	10352039	1
20	Bearing Holder Sub-assy	26152028	1
21	Cross Flow Fan 2	10352040	1
22	Filter Sub-Assy	11120012	1
23	O-Gasket sub-assy of Bearing	76512051	1
24	Strainer A	0721002201	1
25	Electronic Expansion Valve	07334468	1
26	Evaporator Assy	011001000608	1
27	Wall Mounting Frame	01252398	1
28	Fan Motor	1501213401	1
29	Pipe Clamp	26112071	1
30	Drainage Hose	0523001404	1
31	Cover Plate	20122124	1
32	Stepping Motor	1501207902	1
33	Press Plate(Crank)	26112070	1
34	Crank-guide	10582041	1
35	Upper Crank	10562004	1
36	Lower crank	10562005	1
37	Stepping Motor	15012122	1
38	Electric Box Assy	100002003763	1
39	Electric Box	201022502	1
40	Terminal Board	42010268	1
41	Main Board	300002000701	1
42	Display Board	30565087	1
43	Electric Box Cover	201022523	1
44	Electric Box Cover	2011204404S	1

No.	Name of part	For the following unit	
		Unit	Product Code
		GMV-ND80G/A3A-T	CM100N2620
		GMV-ND90G/A3A-T	CM100N2630
		GMV-ND100G/A3A-T	CM100N2640
		Part code	Quantity
45	Remote Controller	30510589	1
46	Electric Expand Valve Fitting	4304413217	1
47	Fan Bearing	7651221001	1
48	Fan Bearing	76512210	1
49	Temperature Sensor	390002072	1
50	Temperature Sensor	39000076G	1
51	Temperature Sensor	390000454	1

Above data is subject to change without notice, pls refer the SP in global service website.

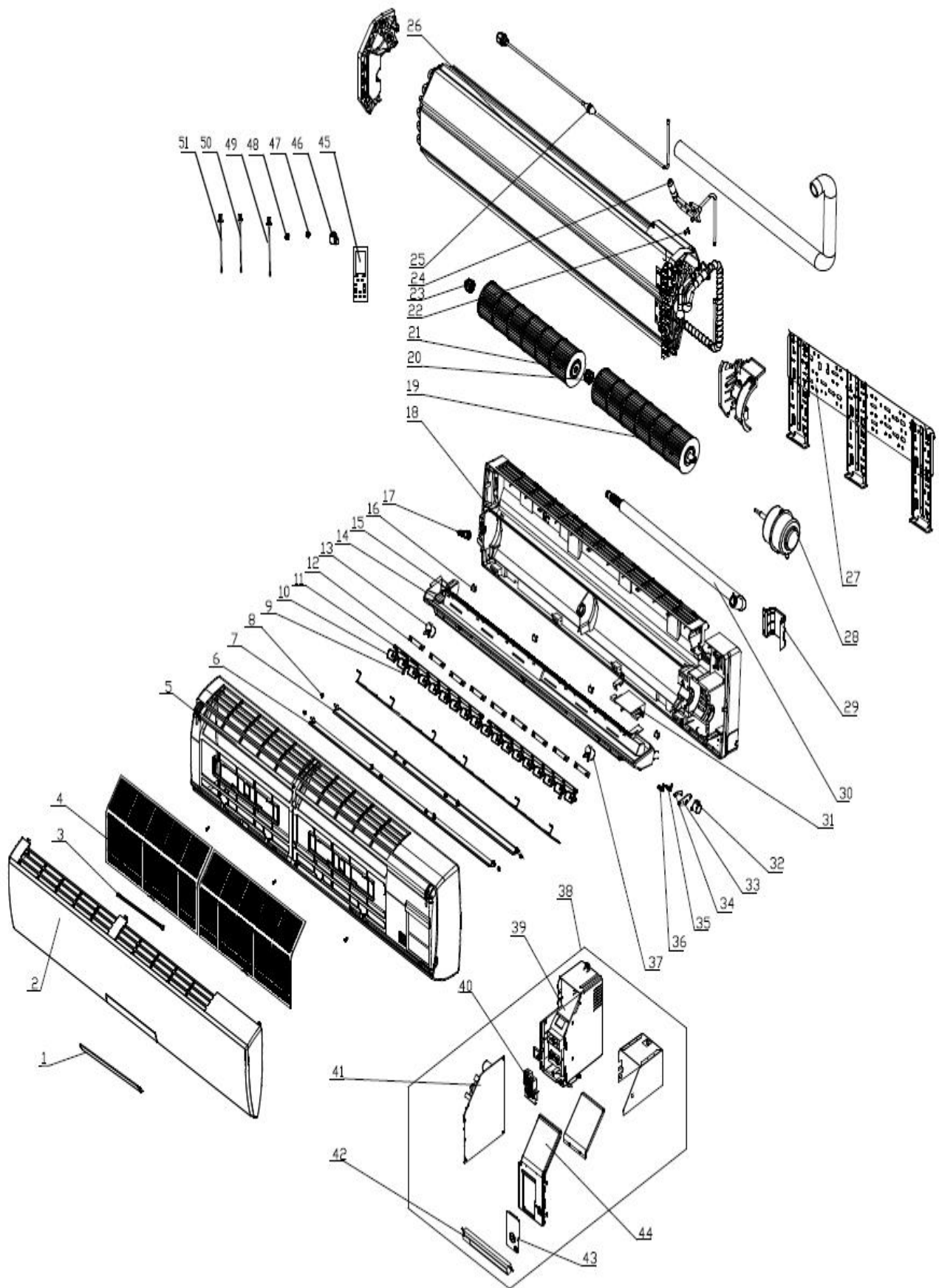

No.	Name of part	For the following unit	
		Unit	Product Code
		GMV-ND80G/B4B-T	CM100N2930
		GMV-ND90G/B4B -T	CM100N2940
		GMV-ND100G/B4B -T	CM100N2840
	Part code	Quantity	
1	Receiver Window	22432164	0
2	Front Panel	20022158C	1
3	Stand Bar	2421212001	1
4	Filter Sub-Assy	1112210601	2
5	Front Case Sub-assy	209007060019	1
6	Upper Guide Louver	10512166	1
7	Lower Guide Louver	10512167	1
8	Axile Bush	10542704	6
9	Air Louver 2	10512169	2
10	Air Louver 1	10512168	16
11	Connecting Rod	10582086	2
12	Louver Clamp	26112127	9
13	Stepping Motor	1521210701	1
14	Water Tray	20182138	1
15	Air Guider System in Water Tray Assy	10102040	1
16	Screw Cover	242520053	4
17	Rubber Plug (Water Tray)	76712012	1
18	Rear Case Sub-Assy	22202703	1
19	Cross Flow Fan 1	10352039	1
20	Bearing Holder Sub-assy	26152028	1
21	Cross Flow Fan 2	10352040	1
22	Filter Sub-Assy	11120012	1
23	O-Gasket sub-assy of Bearing	76512051	1
24	Strainer A	0721002201	1
25	Electronic Expansion Valve	07334468	1
26	Evaporator Assy	011001000608	1
27	Wall Mounting Frame	01252398	1
28	Fan Motor	1501213401	1
29	Pipe Clamp	26112071	1
30	Drainage Hose	0523001404	1
31	Cover Plate	2012212402	1
32	Stepping Motor	1501207902	1
33	Press Plate(Crank)	26112070	1
34	Crank-guide	10582041	1
35	Upper Crank	10562004	1
36	Lower crank	10562005	1
37	Stepping Motor	15012122	1
38	Electric Box Assy	100002063782	1
39	Electric Box	201022502	1
45	Remote Controller	30510589	1
46	Electric Expand Valve Fitting	4304413217	1
47	Fan Bearing	7651221001	1
48	Fan Bearing	76512210	1
49	Temperature Sensor	390002072	1

No.	Name of part	For the following unit	
		Unit	Product Code
		GMV-ND80G/B4B-T	CM100N2930
		GMV-ND90G/B4B -T	CM100N2940
		GMV-ND100G/B4B -T	CM100N2840
Part code	Quantity		
50	Temperature Sensor	39000076G	1
51	Temperature Sensor	390000454	1

Above data is subject to change without notice, pls reference the SP in global service website.

Exploded View of GMV-ND22G/B6B-T, GMV-ND28G/B6B-T, GMV-ND36G/B6B-T:

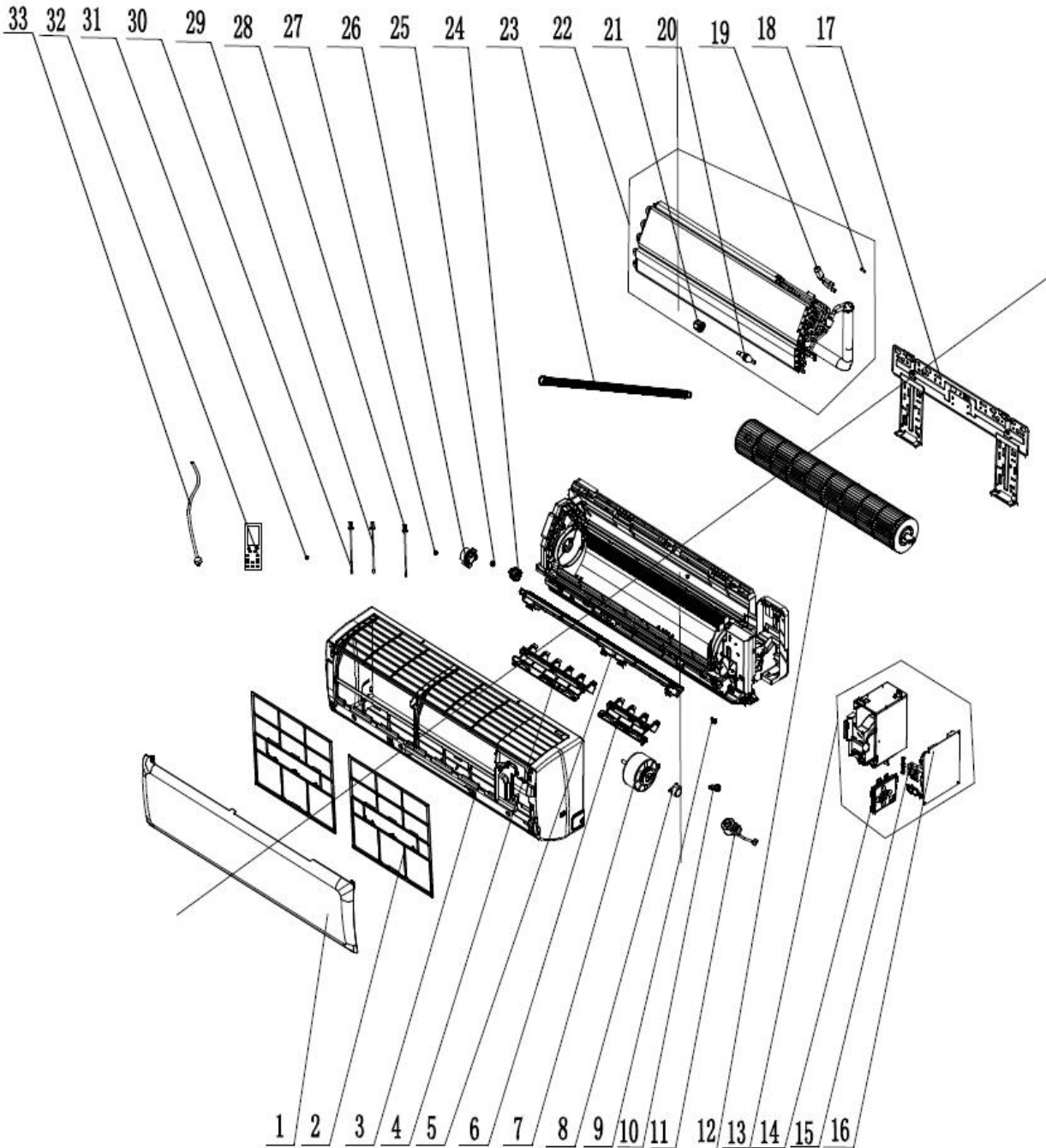

No.	Name of part	For the following unit	
		Unit	Product Code
		GMV-ND22G/B6B-T	CM100N3240
		GMV-ND28G/B6B-T	CM100N3270
		GMV-ND36G/B6B-T	CM100N3210
		Part code	Quantity
1	Front Panel	20000300049T	1
2	Filter Sub-Assy	11122468	2
3	Front CaseAssy	00000200045	1
4	Air Louver1	10512723	1
5	Helicoid Tongue	26112436	1
6	Air Louver2	10512724	1
7	Fan Motor	1501246601	1
8	Stepping Motor	1521210710	1
9	Crank	73012005	1
10	Rubber Plug(WaterTray)	76712012	1
11	Electric Expand ValveFitting	4304413216	1
12	Cross Flow Fan	10352056	1
13	Electric Box Assy	100002061039	1
14	Display Board	30565281	1
15	Terminal Board	4201026805	1
16	Main Board	300002061506	1
17	Wall Mounting Frame	01252484	1
18	Filter Sub-Assy	11120011	1
19	Electronic Expansion Valve	07334463	1
20	Strainer A	0721002201	1
21	Sealing Cap(PressureWarning)	2611219201	1
22	Evaporator Assy	011001060163	1
23	Drainage Hose	05230014	1
24	O-Gasket of Cross FanBearing	76512203	1
25	Fan Bearing	7651221001	1
26	Ring of Bearing	26152022	1
27	Left Axile Bush	10512037	1
28	Temperature Sensor	390000454	1
29	Temperature Sensor	39000076G	1
30	Temperature Sensor	390002072	1
31	Axile Bush	10542036	1
32	Remote Controller	30510589	1
33	Power Cord	4002046417	1

Above data is subject to change without notice, pls reference the SP in global service website.

Exploded View of GMV-ND15G/B4B-T 、 GMV-ND18G/B4B-T 、 GMV-ND22G/B4B-T 、 GMV-ND28G/B4B-T、 GMV-ND36G/B4B-T:

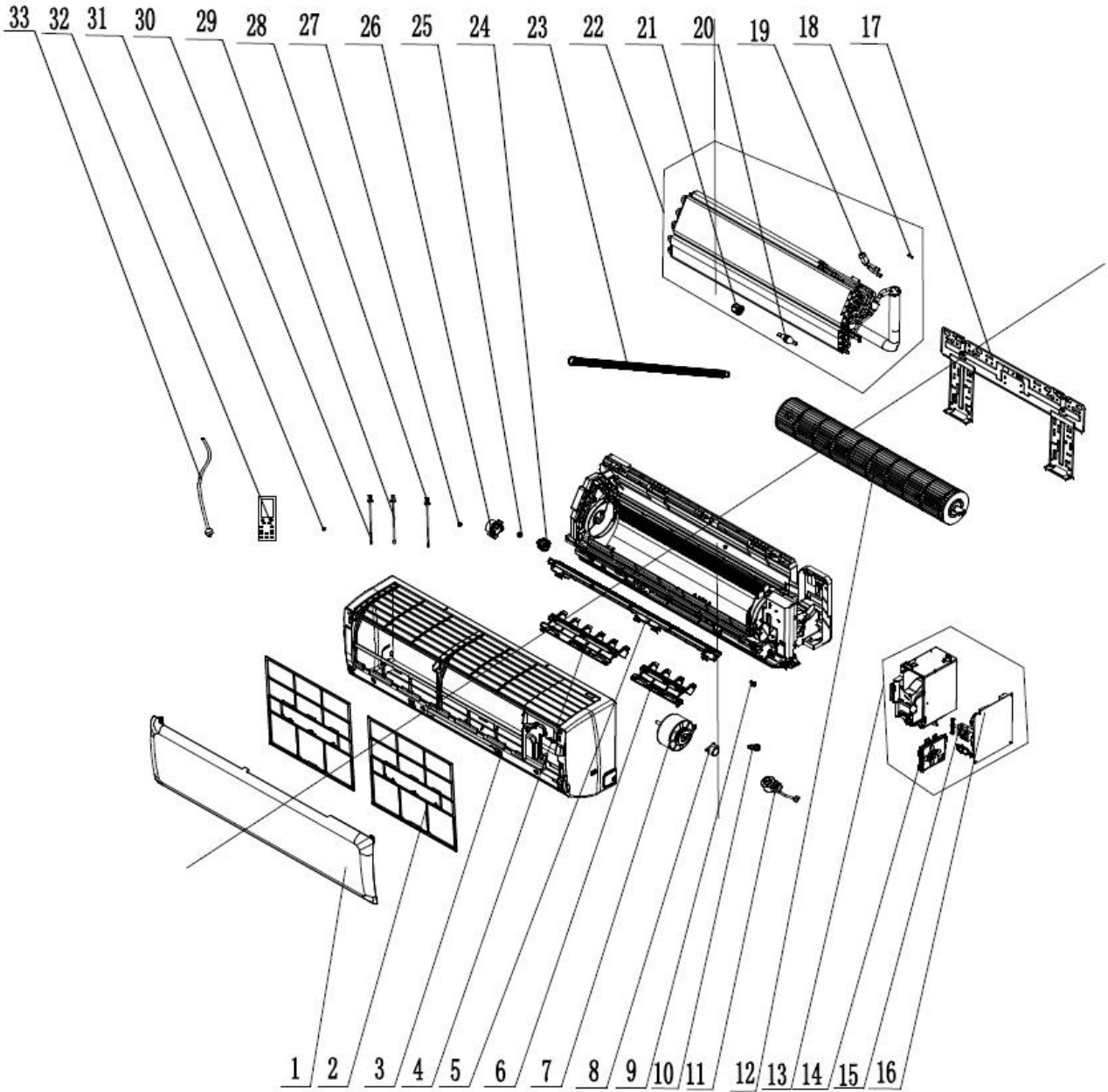

No.	Name of part	For the following unit	
		Unit	Product Code
		GMV-ND15G/B4B-T	CM100N3280
		GMV-ND18G/B4B-T	CM100N3290
		GMV-ND22G/B4B-T	CM100N2770
		GMV-ND28G/B4B-T	CM100N2780
		GMV-ND36G/B4B-T	CM100N2760
	Part code	Quantity	
1	Front Panel	20000300027T	1
2	Filter Sub-Assy	11122468	2
3	Front CaseAssy	00000200045	1
4	Air Louver1	10512723	1
5	Helicoid Tongue	26112436	1
6	Air Louver2	10512724	1
7	Fan Motor	1501246601	1
8	Stepping Motor	1521210710	1
9	Crank	73012005	1
10	Rubber Plug(WaterTray)	76712012	1
11	Electric Expand ValveFitting	4304413216	1
12	Cross Flow Fan	10352056	1
13	Electric Box Assy	100002061039	1
14	Display Board	30565260	1
15	Terminal Board	4201026805	1
16	Main Board	300002060244	1
17	Wall Mounting Frame	01252484	1
18	Filter Sub-Assy	11120011	1
19	Electronic Expansion Valve	07334463	1
20	Strainer A	0721002201	1
21	Sealing Cap(PressureWarning)	2611219201	1
22	Evaporator Assy	011001060163	1
23	Drainage Hose	05230014	1
24	O-Gasket of Cross FanBearing	76512203	1
25	Fan Bearing	7651221001	1
26	Ring of Bearing	26152022	1
27	Left Axile Bush	10512037	1
28	Temperature Sensor	390000454	1
29	Temperature Sensor	39000076G	1
30	Temperature Sensor	390002072	1
31	Axile Bush	10542036	1
32	Remote Controller	30510589	1
33	Power Cord	4002046417	1

Above data is subject to change without notice, pls reference the SP in global service website.

Exploded View of GMV-ND22G/C4B-T、GMV-ND28G/C4B-T、GMV-ND36G/C4B-T:

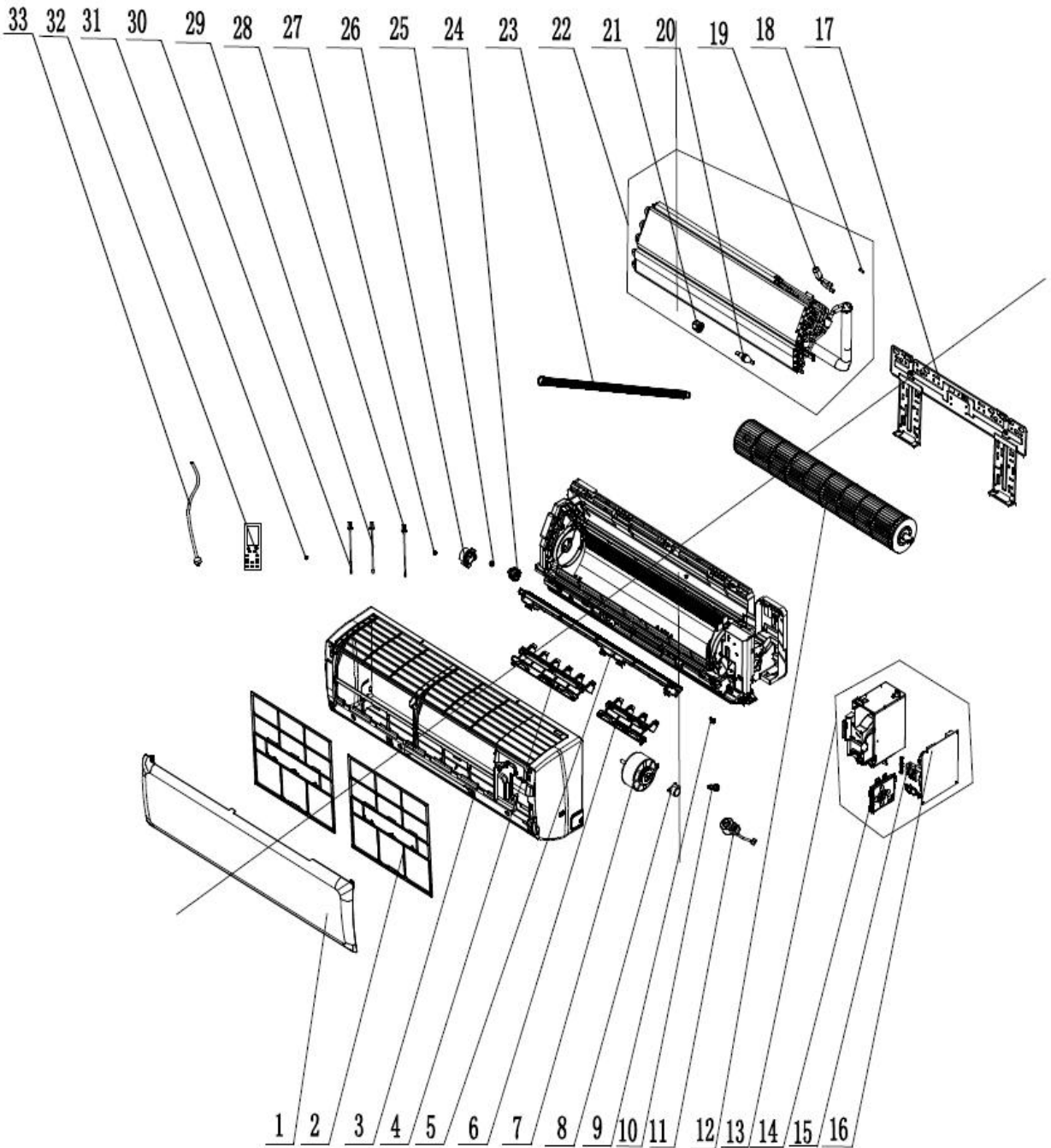

No.	Name of part	For the following unit	
		Unit	Product Code
		GMV-ND22G/C4B-T	CM100N3140
		GMV-ND28G/C4B-T	CM100N3130
		GMV-ND36G/C4B-T	CM100N3150
		Part code	Quantity
1	Front Panel	20000300098S	1
2	Filter Sub-Assy	11122468	2
3	Front CaseAssy	00000200045	1
4	Air Louver1	10512723	1
5	Helicoid Tongue	26112436	1
6	Air Louver2	10512724	1
7	Fan Motor	1501246601	1
8	Stepping Motor	1521210710	1
9	Crank	73012005	1
10	Rubber Plug(WaterTray)	76712012	1
11	Electric Expand ValveFitting	4304413216	1
12	Cross Flow Fan	10352056	1
13	Electric Box Assy	100002061039	1
14	Display Board	30565260	1
15	Terminal Board	4201026805	1
16	Main Board	300002060244	1
17	Wall Mounting Frame	01252484	1
18	Filter Sub-Assy	11120011	1
19	Electronic Expansion Valve	07334463	1
20	Strainer A	0721002201	1
21	Sealing Cap(PressureWarning)	2611219201	1
22	Evaporator Assy	011001060163	1
23	Drainage Hose	05230014	1
24	O-Gasket of Cross FanBearing	76512203	1
25	Fan Bearing	7651221001	1
26	Ring of Bearing	26152022	1
27	Left Axile Bush	10512037	1
28	Temperature Sensor	390000454	1
29	Temperature Sensor	39000076G	1
30	Temperature Sensor	390002072	1
31	Axile Bush	10542036	1
32	Remote Controller	30510589	1
33	Power Cord	4002046417	1

Above data is subject to change without notice, pls reference the SP in global service website.

Exploded View of GMV-ND22G/C2B-T、GMV-ND28G/C2B-T、GMV-ND36G/C2B-T:

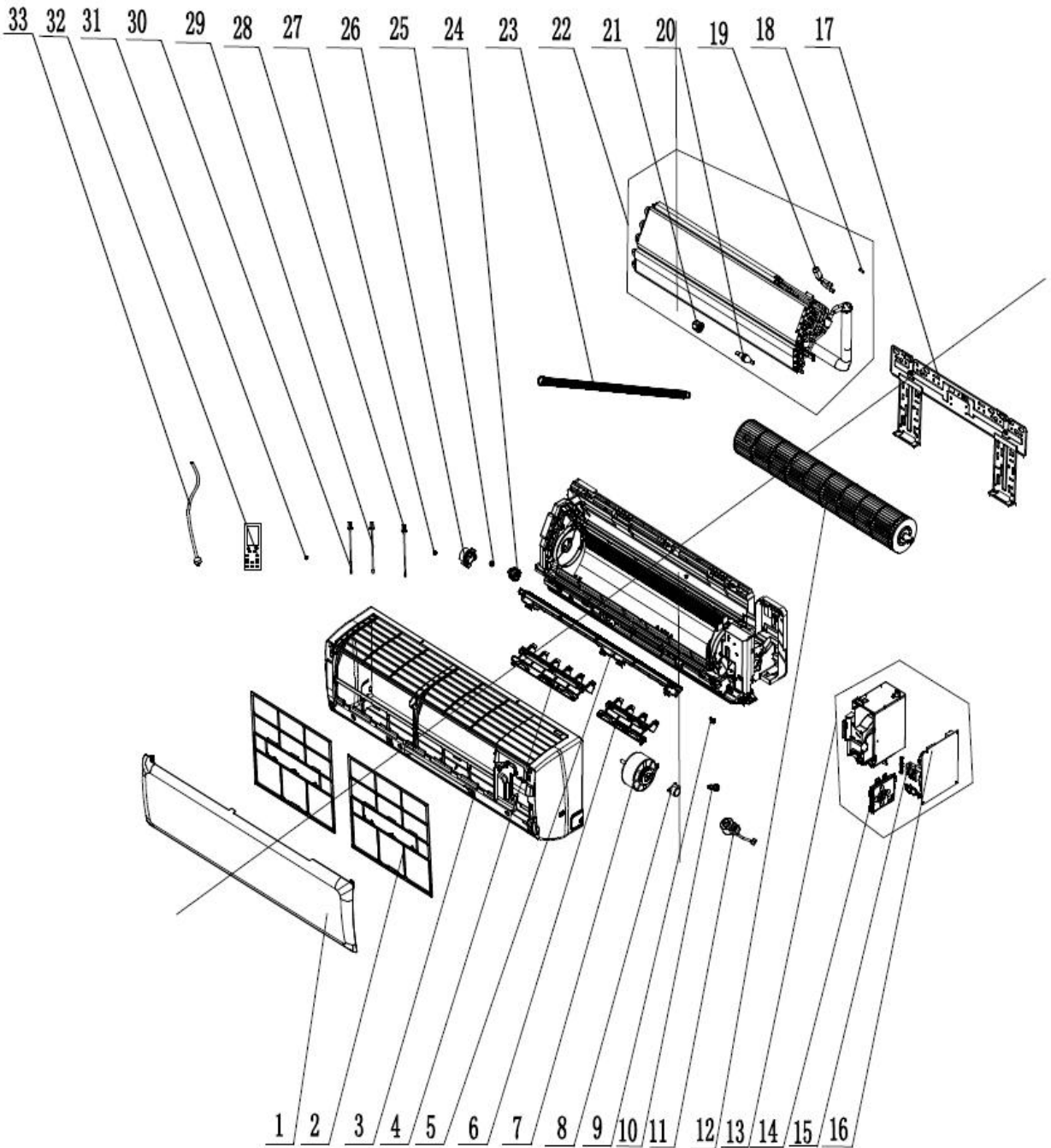

No.	Name of part	For the following unit	
		Unit	Product Code
		GMV-ND22G/C2B-T	CM100N3040
		GMV-ND28G/C2B-T	CM100N3080
		GMV-ND36G/C2B-T	CM100N3050
		Part code	Quantity
1	Front Panel	20000300069S	1
2	Filter Sub-Assy	11122468	2
3	Front CaseAssy	00000200045	1
4	Air Louver1	10512723	1
5	Helicoid Tongue	26112436	1
6	Air Louver2	10512724	1
7	Fan Motor	1501246601	1
8	Stepping Motor	1521210710	1
9	Crank	73012005	1
10	Rubber Plug(WaterTray)	76712012	1
11	Electric Expand ValveFitting	4304413216	1
12	Cross Flow Fan	10352056	1
13	Electric Box Assy	100002061039	1
14	Display Board	30565281	1
15	Terminal Board	4201026805	1
16	Main Board	300002060244	1
17	Wall Mounting Frame	01252484	1
18	Filter Sub-Assy	11120011	1
19	Electronic Expansion Valve	07334463	1
20	Strainer A	0721002201	1
21	Sealing Cap(PressureWarning)	2611219201	1
22	Evaporator Assy	011001060163	1
23	Drainage Hose	05230014	1
24	O-Gasket of Cross FanBearing	76512203	1
25	Fan Bearing	7651221001	1
26	Ring of Bearing	26152022	1
27	Left Axile Bush	10512037	1
28	Temperature Sensor	390000454	1
29	Temperature Sensor	39000076G	1
30	Temperature Sensor	390002072	1
31	Axile Bush	10542036	1
32	Remote Controller	30510589	1
33	Power Cord	4002046417	1

Above data is subject to change without notice,pls reference the SP in global service website.

Exploded View of GMV-ND22G/D2B-T、GMV-ND28G/D2B-T、GMV-ND36G/D2B-T:

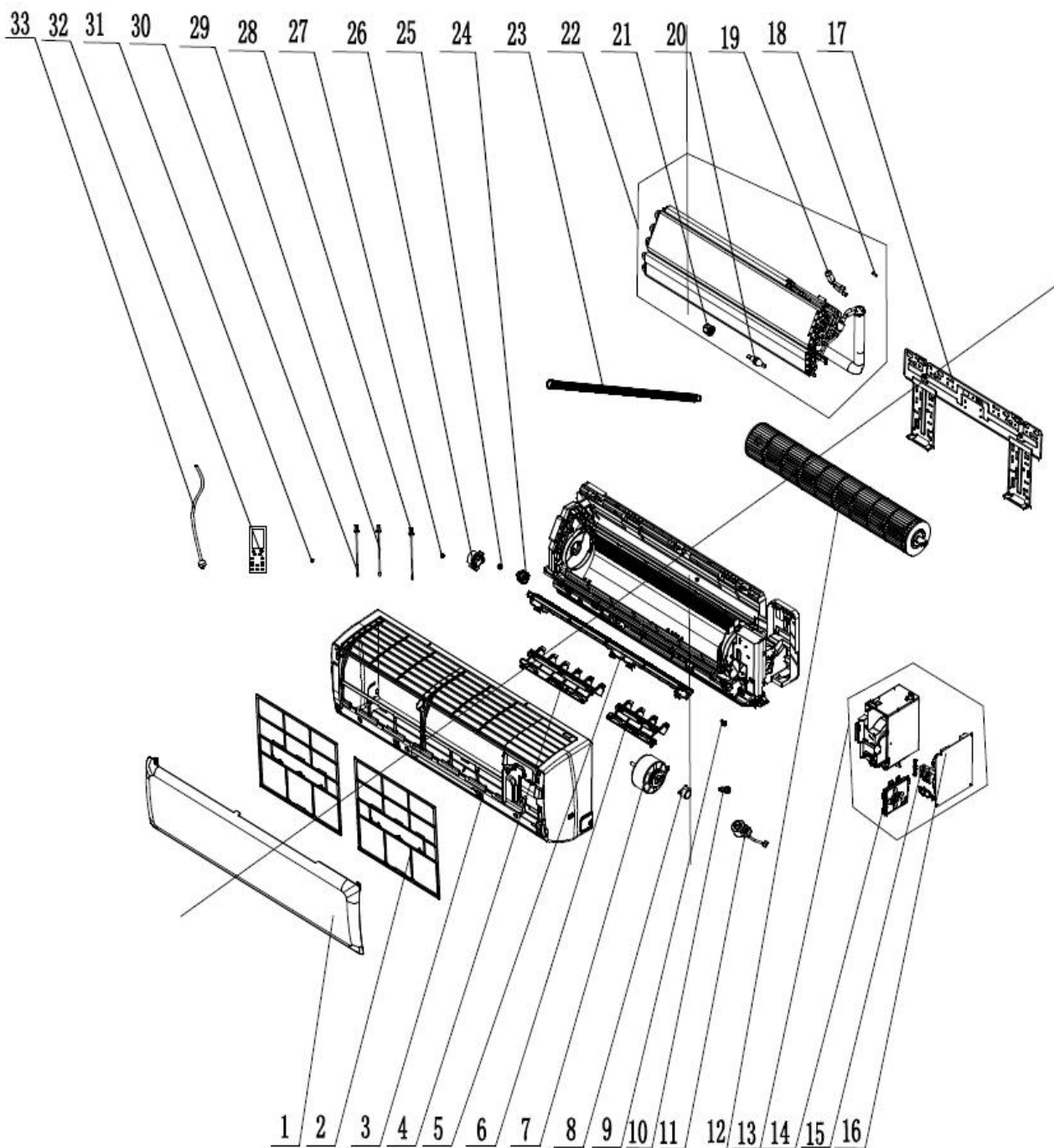

No.	Name of part	For the following unit	
		Unit	Product Code
		GMV-ND22G/D2B-T	CM100N2850
		GMV-ND28G/D2B-T	CM100N2860
		GMV-ND36G/D2B-T	CM100N2870
	Part code	Quantity	
1	Front Panel	00000300003303	1
2	Filter Sub-Assy	11122468	2
3	Front CaseAssy	00000200000703	1
4	Air Louver1	10512723	1
5	Helicoid Tongue	26112436	1
6	Air Louver2	10512724	1
7	Fan Motor	1501246601	1
8	Stepping Motor	1521210710	1
9	Crank	73012005	1
10	Rubber Plug(WaterTray)	76712012	1
11	Electric Expand ValveFitting	4304413216	1
12	Cross Flow Fan	10352056	1
13	Electric Box Assy	100002061039	1
14	Display Board	30565260	1
15	Terminal Board	4201026805	1
16	Main Board	300002060244	1
17	Wall Mounting Frame	01252484	1
18	Filter Sub-Assy	11120011	1
19	Electronic Expansion Valve	07334463	1
20	Strainer A	0721002201	1
21	Sealing Cap(PressureWarning)	2611219201	1
22	Evaporator Assy	011001060163	1
23	Drainage Hose	05230014	1
24	O-Gasket of Cross FanBearing	76512203	1
25	Fan Bearing	7651221001	1
26	Ring of Bearing	26152022	1
27	Left Axile Bush	10512037	1
28	Temperature Sensor	390000454	1
29	Temperature Sensor	39000076G	1
30	Temperature Sensor	390002072	1
31	Axile Bush	10542036	1
32	Remote Controller	30510589	1
33	Power Cord	4002046417	1

Above data is subject to change without notice,pls reference the SP in global service website.

Exploded View of GMV-ND45G/B6B-T、GMV-ND50G/B6B-T:

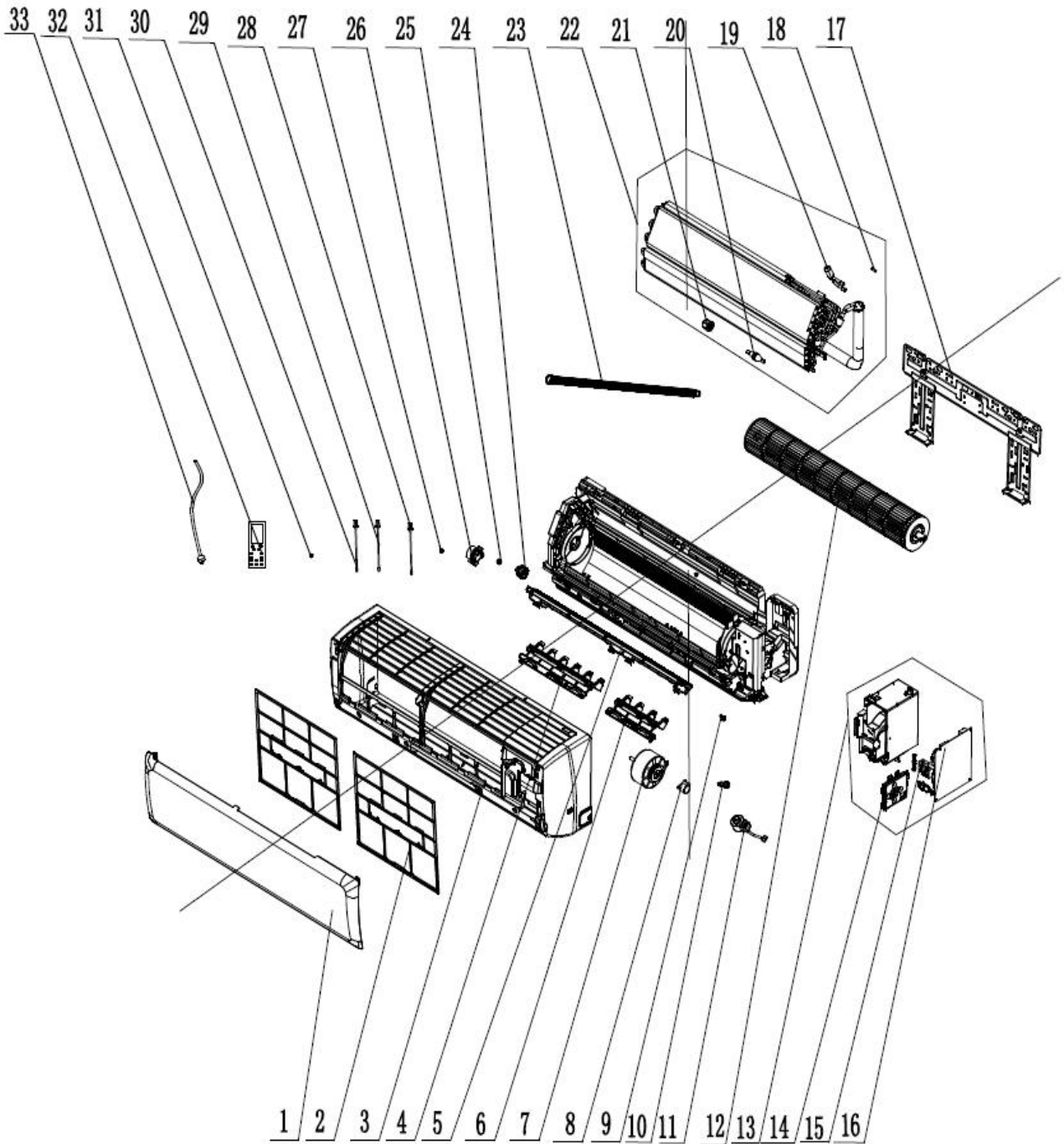

No.	Name of part	For the following unit	
		Unit	Product Code
		GMV-ND45G/B6B-T	CM100N3250
		GMV-ND50G/B6B-T	CM100N3200
		Part code	Quantity
1	Front Panel	20000300040T	1
2	Filter Sub-Assy	1112208906	2
3	Front CaseAssy	00000200042	1
4	Air Louver1	10512732	1
5	Helicoid Tongue	26112512	1
6	Air Louver2	10512724	0
7	Fan Motor	15012136	1
8	Stepping Motor	1521240212	1
9	Crank	73012005	1
10	Rubber Plug(WaterTray)	76712012	1
11	Electric Expand ValveFitting	4304413216	1
12	Cross Flow Fan	10352060	1
13	Electric Box Assy	100002061356	1
14	Display Board	30565281	1
15	Terminal Board	4201026805	1
16	Main Board	300002061506	1
17	Wall Mounting Frame	01362026	1
18	Filter Sub-Assy	030209060001	1
19	Electronic Expansion Valve	07334466	1
20	Strainer A	0721002201	1
21	Sealing Cap(PressureWarning)	2611219202	1
22	Evaporator Assy	011001060216	1
23	Drainage Hose	05230014	1
24	O-Gasket of Cross FanBearing	76512203	1
25	Fan Bearing	7651221001	1
26	Ring of Bearing	26152025	1
27	Left Axile Bush	10512037	1
28	Temperature Sensor	390000454	1
29	Temperature Sensor	39000076G	1
30	Temperature Sensor	390002072	1
31	Axile Bush	10542036	1
32	Remote Controller	30510589	1
33	Power Cord	4002046417	1

Above data is subject to change without notice,pls reference the SP in global service website.

Exploded View of GMV-ND45G/B4B-T、GMV-ND50G/B4B-T:

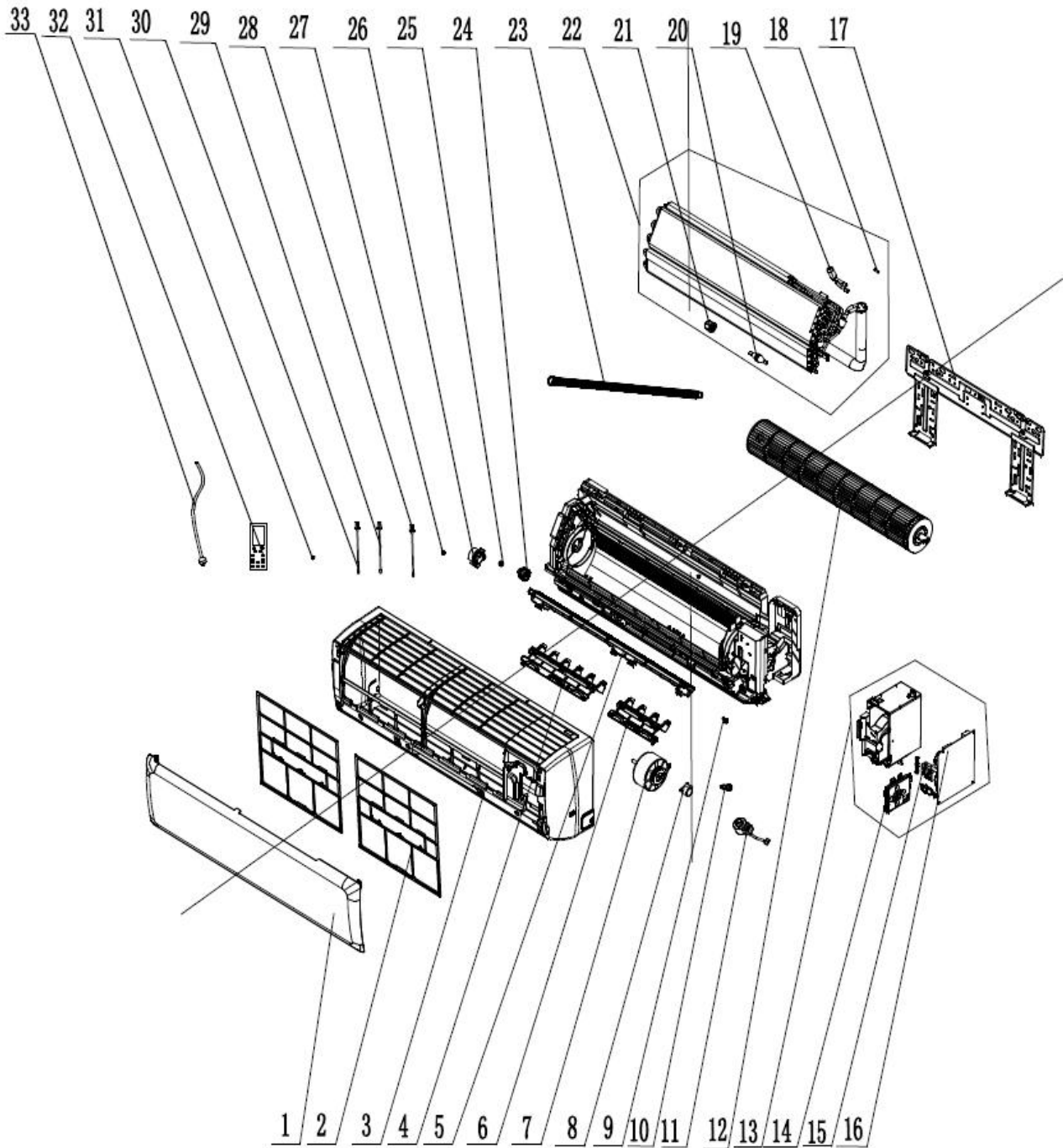

No.	Name of part	For the following unit	
		Unit	Product Code
		GMV-ND45G/B4B-T	CM100N2790
		GMV-ND50G/B4B-T	CM100N2800
		Part code	Quantity
1	Front Panel	20000300028T	1
2	Filter Sub-Assy	1112208906	2
3	Front CaseAssy	00000200042	1
4	Air Louver1	10512732	1
5	Helicoid Tongue	26112512	1
6	Air Louver2	10512724	0
7	Fan Motor	15012136	1
8	Stepping Motor	1521240212	1
9	Crank	73012005	1
10	Rubber Plug(WaterTray)	76712012	1
11	Electric Expand ValveFitting	4304413216	1
12	Cross Flow Fan	10352060	1
13	Electric Box Assy	100002061356	1
14	Display Board	30565260	1
15	Terminal Board	4201026805	1
16	Main Board	300002060244	1
17	Wall Mounting Frame	01362026	1
18	Filter Sub-Assy	030209060001	1
19	Electronic Expansion Valve	07334466	1
20	Strainer A	0721002201	1
21	Sealing Cap(PressureWarning)	2611219202	1
22	Evaporator Assy	011001060216	1
23	Drainage Hose	05230014	1
24	O-Gasket of Cross FanBearing	76512203	1
25	Fan Bearing	7651221001	1
26	Ring of Bearing	26152025	1
27	Left Axile Bush	10512037	1
28	Temperature Sensor	390000454	1
29	Temperature Sensor	39000076G	1
30	Temperature Sensor	390002072	1
31	Axile Bush	10542036	1
32	Remote Controller	30510589	1
33	Power Cord	4002046417	1

Above data is subject to change without notice,pls reference the SP in global service website.

Exploded View of GMV-ND45G/C4B-T、GMV-ND50G/C4B-T:

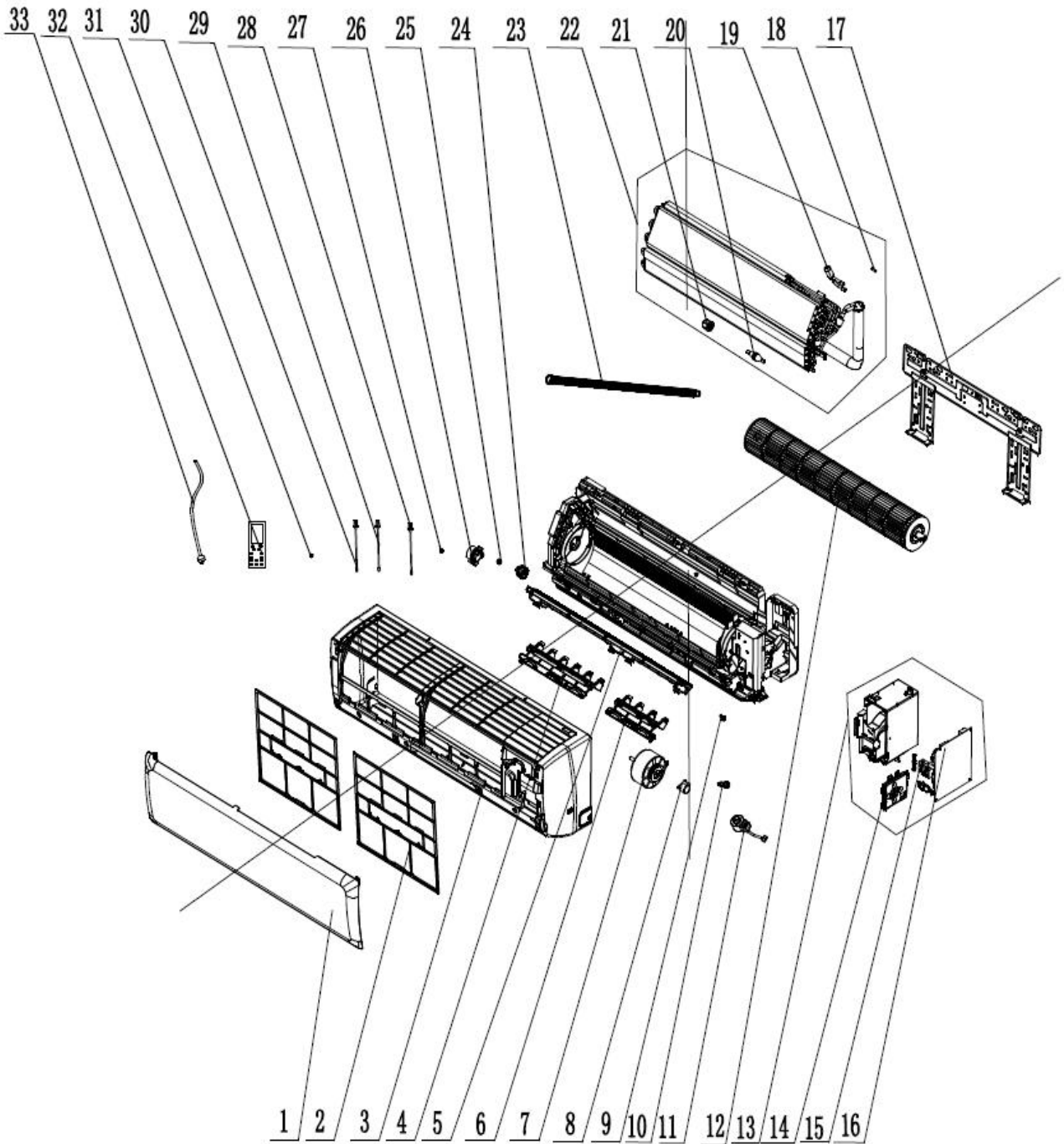

No.	Name of part	For the following unit	
		Unit	Product Code
		GMV-ND45G/C4B-T	CM100N3120
		GMV-ND50G/C4B-T	CM100N3160
		Part code	Quantity
1	Front Panel	20000300106S	1
2	Filter Sub-Assy	1112208906	2
3	Front CaseAssy	00000200042	1
4	Air Louver1	10512732	1
5	Helicoid Tongue	26112512	1
6	Air Louver2	10512724	0
7	Fan Motor	15012136	1
8	Stepping Motor	1521240212	1
9	Crank	73012005	1
10	Rubber Plug(WaterTray)	76712012	1
11	Electric Expand ValveFitting	4304413216	1
12	Cross Flow Fan	10352060	1
13	Electric Box Assy	100002061356	1
14	Display Board	30565260	1
15	Terminal Board	4201026805	1
16	Main Board	300002060244	1
17	Wall Mounting Frame	01362026	1
18	Filter Sub-Assy	030209060001	1
19	Electronic Expansion Valve	07334466	1
20	Strainer A	0721002201	1
21	Sealing Cap(PressureWarning)	2611219202	1
22	Evaporator Assy	011001060216	1
23	Drainage Hose	05230014	1
24	O-Gasket of Cross FanBearing	76512203	1
25	Fan Bearing	7651221001	1
26	Ring of Bearing	26152025	1
27	Left Axile Bush	10512037	1
28	Temperature Sensor	390000454	1
29	Temperature Sensor	39000076G	1
30	Temperature Sensor	390002072	1
31	Axile Bush	10542036	1
32	Remote Controller	30510589	1
33	Power Cord	4002046417	1

Above data is subject to change without notice,pls reference the SP in global service website.

Exploded View of GMV-ND45G/C2B-T、GMV-ND50G/C2B-T:

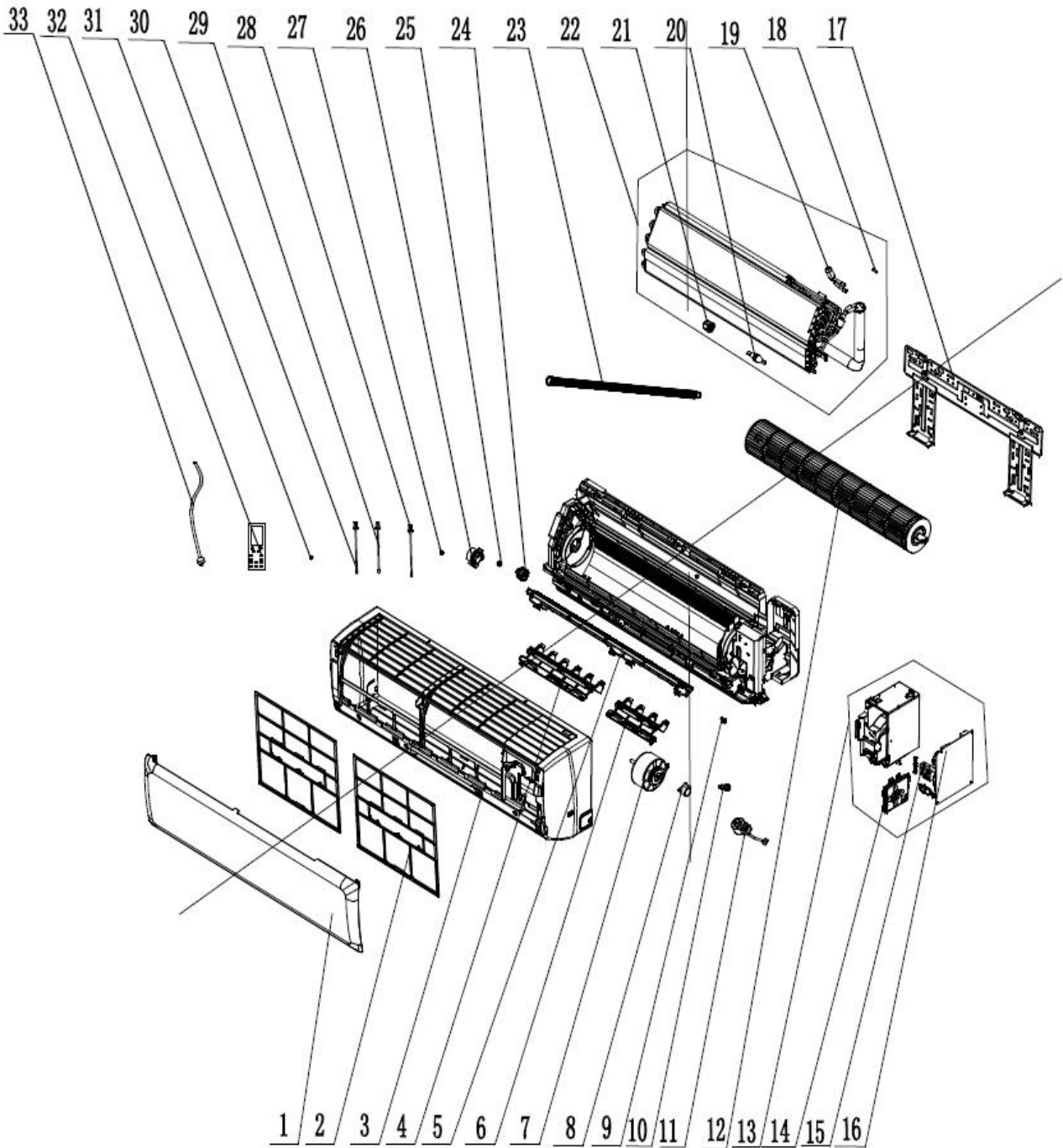

No.	Name of part	For the following unit	
		Unit	Product Code
		GMV-ND45G/C2B-T	CM100N3060
		GMV-ND50G/C2B-T	CM100N3070
		Part code	Quantity
1	Front Panel	20000300070S	1
2	Filter Sub-Assy	1112208906	2
3	Front CaseAssy	00000200042	1
4	Air Louver1	10512732	1
5	Helicoid Tongue	26112512	1
6	Air Louver2	10512724	0
7	Fan Motor	15012136	1
8	Stepping Motor	1521240212	1
9	Crank	73012005	1
10	Rubber Plug(WaterTray)	76712012	1
11	Electric Expand ValveFitting	4304413216	1
12	Cross Flow Fan	10352060	1
13	Electric Box Assy	100002061356	1
14	Display Board	30565281	1
15	Terminal Board	4201026805	1
16	Main Board	300002060244	1
17	Wall Mounting Frame	01362026	1
18	Filter Sub-Assy	030209060001	1
19	Electronic Expansion Valve	07334466	1
20	Strainer A	0721002201	1
21	Sealing Cap(PressureWarning)	2611219202	1
22	Evaporator Assy	011001060216	1
23	Drainage Hose	05230014	1
24	O-Gasket of Cross FanBearing	76512203	1
25	Fan Bearing	7651221001	1
26	Ring of Bearing	26152025	1
27	Left Axile Bush	10512037	1
28	Temperature Sensor	390000454	1
29	Temperature Sensor	39000076G	1
30	Temperature Sensor	390002072	1
31	Axile Bush	10542036	1
32	Remote Controller	30510589	1
33	Power Cord	4002046417	1

Above data is subject to change without notice,pls reference the SP in global service website.

Exploded View of GMV-ND45G/D2B-T、GMV-ND50G/D2B-T:

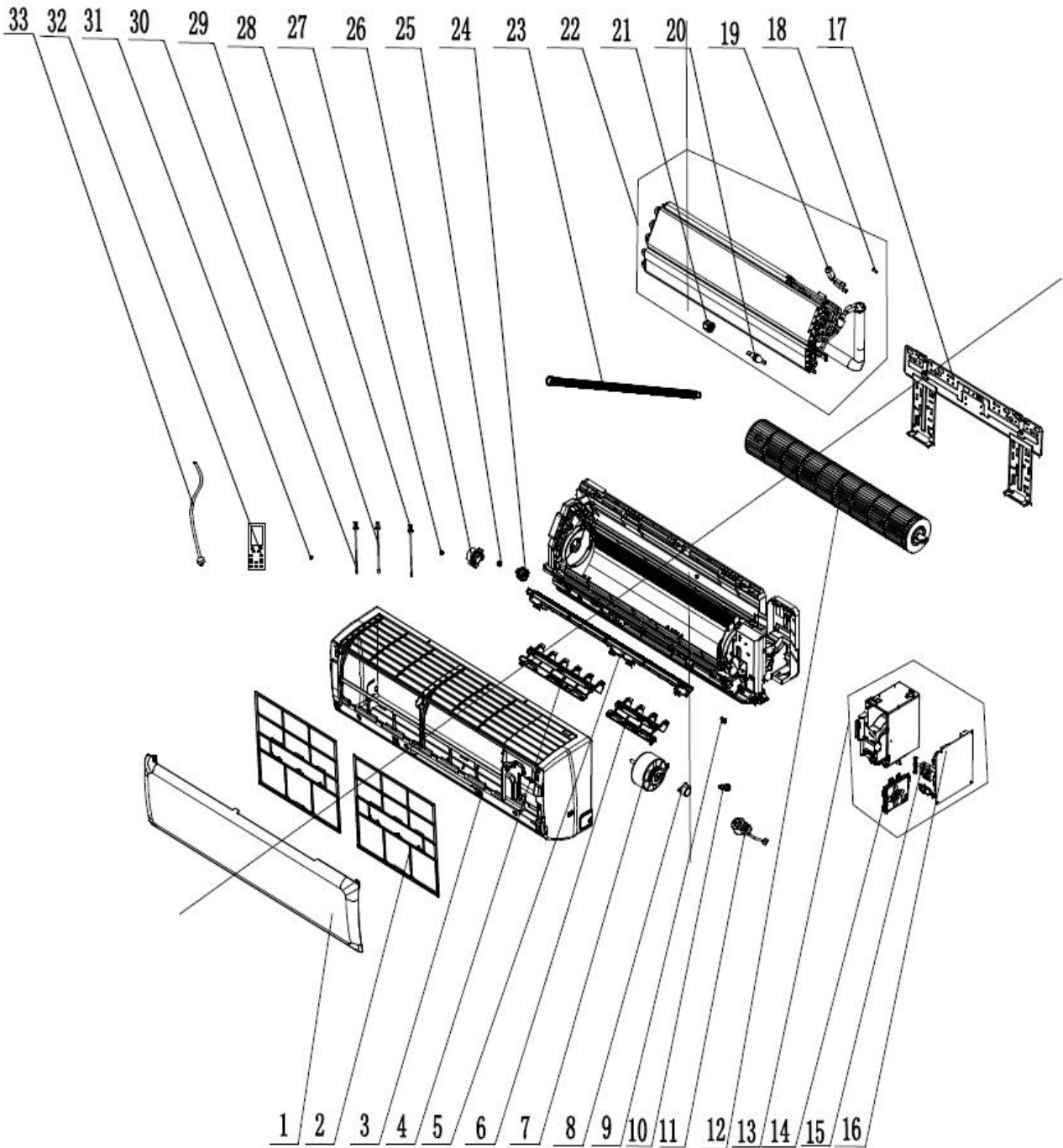

No.	Name of part	For the following unit	
		Unit	Product Code
		GMV-ND45G/D2B-T	CM100N2880
		GMV-ND50G/D2B-T	CM100N2890
		Part code	Quantity
1	Front Panel	00000300003104	1
2	Filter Sub-Assy	1112208906	2
3	Front CaseAssy	0000020004203	1
4	Air Louver1	10512732	3
5	Helicoid Tongue	26112512	1
6	Air Louver2	10512724	0
7	Fan Motor	15012136	1
8	Stepping Motor	1521240212	1
9	Crank	73012005	1
10	Rubber Plug(WaterTray)	76712012	1
11	Electric Expand ValveFitting	4304413216	1
12	Cross Flow Fan	10352060	1
13	Electric Box Assy	100002061356	1
14	Display Board	30565260	1
15	Terminal Board	4201026805	1
16	Main Board	300002060244	1
17	Wall Mounting Frame	01362026	1
18	Filter Sub-Assy	030209060001	1
19	Electronic Expansion Valve	07334466	1
20	Strainer A	0721002201	1
21	Sealing Cap(PressureWarning)	2611219202	1
22	Evaporator Assy	011001060216	1
23	Drainage Hose	05230014	1
24	O-Gasket of Cross FanBearing	76512203	1
25	Fan Bearing	7651221001	1
26	Ring of Bearing	26152025	1
27	Left Axile Bush	10512037	1
28	Temperature Sensor	390000454	1
29	Temperature Sensor	39000076G	1
30	Temperature Sensor	390002072	1
31	Axile Bush	10542036	1
32	Remote Controller	30510589	1
33	Power Cord	4002046417	1

Above data is subject to change without notice,pls reference the SP in global service website.

Exploded View of GMV-ND56G/B6B-T、GMV-ND63G/B6B-T、GMV-ND71G/B6B-T:

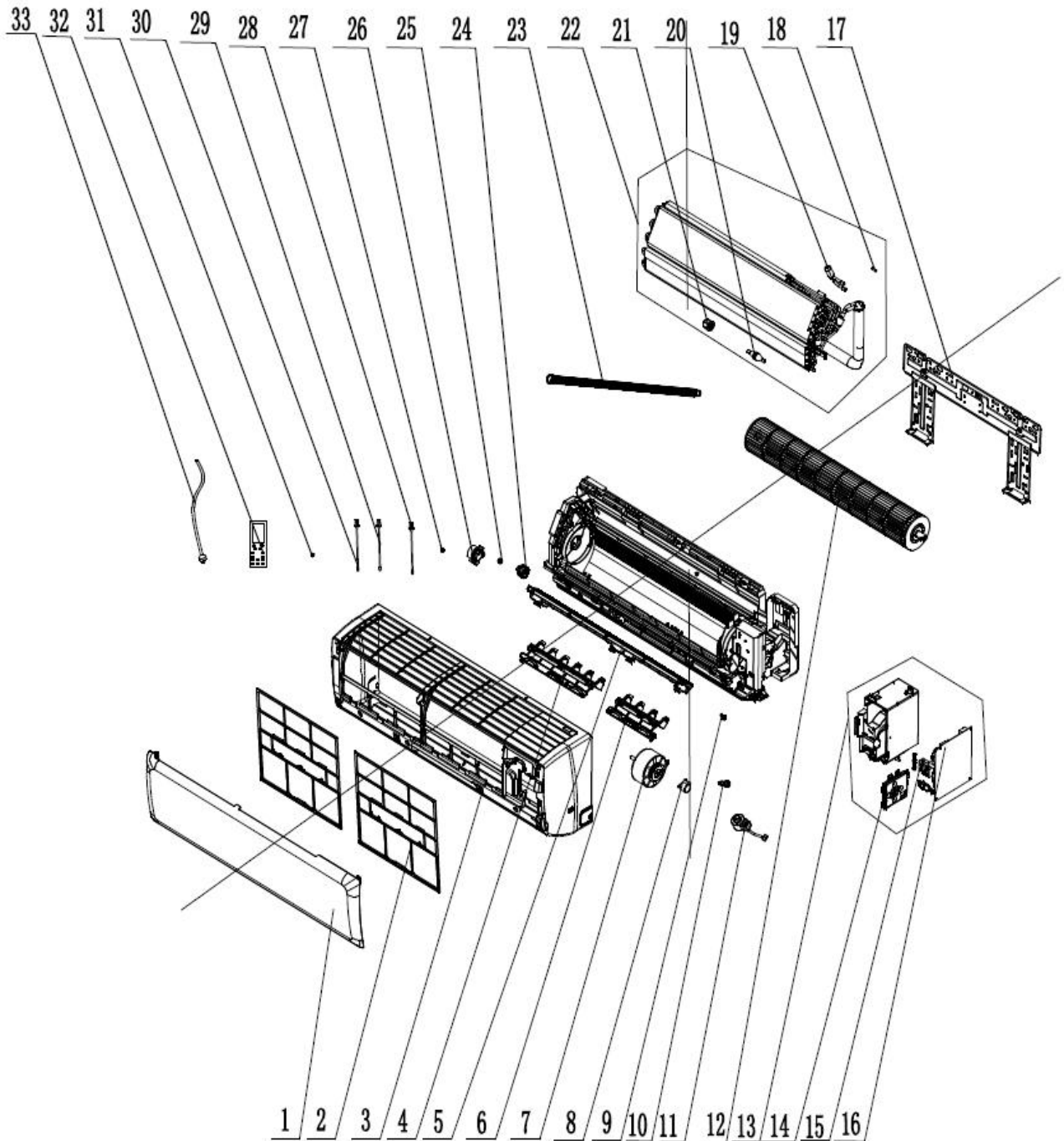

No.	Name of part	For the following unit	
		Unit	Product Code
		GMV-ND56G/B6B-T	CM100N3240
		GMV-ND63G/B6B-T	CM100N3230
		GMV-ND71G/B6B-T	CM100N3220
		Part code	Quantity
1	Front Panel	20000300048T	1
2	Filter Sub-Assy	1101200703	2
3	Front CaseAssy	00000200043	1
4	Air Louver 1	10512737	3
5	Helicoid Tongue	26112513	1
6	Air Louver 2	10512724	0
7	Fan Motor	15012136	1
8	Stepping Motor	1521240212	1
9	Crank	73012005	1
10	Rubber Plug(WaterTray)	76712012	1
11	Electric Expand ValveFitting	4304413216	1
12	Cross Flow Fan	10352057	1
13	Electric Box Assy	100002061356	1
14	Display Board	30565281	1
15	Terminal Board	4201026805	1
16	Main Board	300002061506	1
17	Wall Mounting Frame	01252229	1
18	Filter Sub-Assy	030209060001	1
19	Electronic Expansion Valve	07334466	1
20	Strainer A	0721002201	1
21	Sealing Cap(PressureWarning)	2611219202	1
22	Evaporator Assy	011001060225	1
23	Drainage Hose	05230014	1
24	O-Gasket of Cross FanBearing	76512203	1
25	Fan Bearing	7651221001	1
26	Ring of Bearing	26152025	1
27	Left Axile Bush	10512037	1
28	Temperature Sensor	390000454	1
29	Temperature Sensor	39000076G	1
30	Temperature Sensor	390002072	1
31	Axile Bush	10542036	1
32	Remote Controller	30510589	1
33	Power Cord	4002046417	1

Above data is subject to change without notice,pls reference the SP in global service website.

Exploded View of GMV-ND56G/B4B-T、GMV-ND63G/B4B-T、GMV-ND71G/B4B-T:

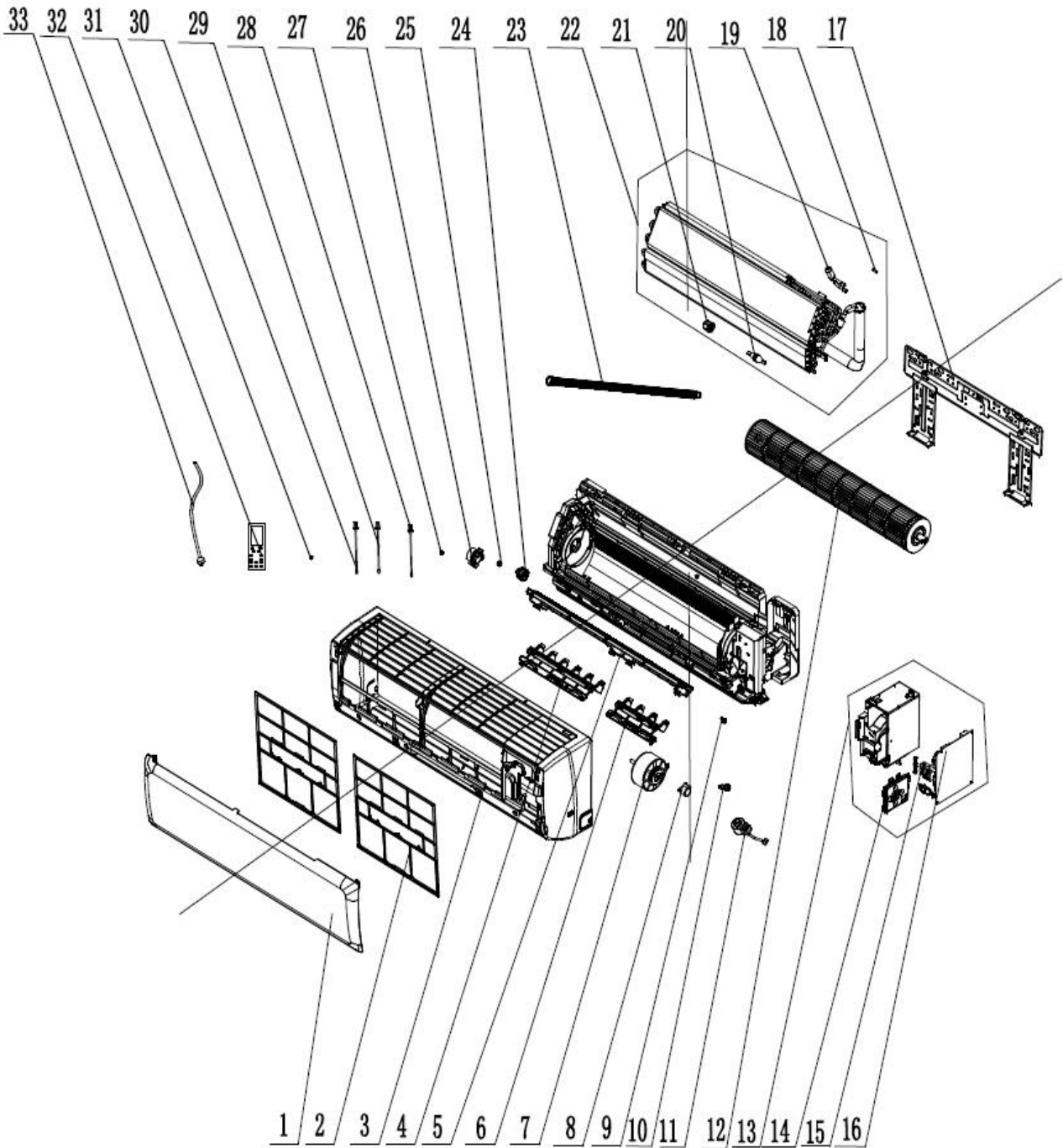

No.	Name of part	For the following unit	
		Unit	Product Code
		GMV-ND56G/B4B-T	CM100N2810
		GMV-ND63G/B4B-T	CM100N2820
		GMV-ND71G/B4B-T	CM100N2830
	Part code	Quantity	
1	Front Panel	20000300029T	1
2	Filter Sub-Assy	1101200703	2
3	Front CaseAssy	00000200043	1
4	Air Louver 1	10512737	3
5	Helicoid Tongue	26112513	1
6	Air Louver 2	10512724	0
7	Fan Motor	15012136	1
8	Stepping Motor	1521240212	1
9	Crank	73012005	1
10	Rubber Plug(WaterTray)	76712012	1
11	Electric Expand ValveFitting	4304413216	1
12	Cross Flow Fan	10352057	1
13	Electric Box Assy	100002061356	1
14	Display Board	30565260	1
15	Terminal Board	4201026805	1
16	Main Board	300002060244	1
17	Wall Mounting Frame	01252229	1
18	Filter Sub-Assy	030209060001	1
19	Electronic Expansion Valve	07334466	1
20	Strainer A	0721002201	1
21	Sealing Cap(PressureWarning)	2611219202	1
22	Evaporator Assy	011001060225	1
23	Drainage Hose	05230014	1
24	O-Gasket of Cross FanBearing	76512203	1
25	Fan Bearing	7651221001	1
26	Ring of Bearing	26152025	1
27	Left Axile Bush	10512037	1
28	Temperature Sensor	390000454	1
29	Temperature Sensor	39000076G	1
30	Temperature Sensor	390002072	1
31	Axile Bush	10542036	1
32	Remote Controller	30510589	1
33	Power Cord	4002046417	1

Above data is subject to change without notice,pls reference the SP in global service website.

Exploded View of GMV-ND56G/C4B-T、GMV-ND63G/C4B-T、GMV-ND71G/C4B-T:

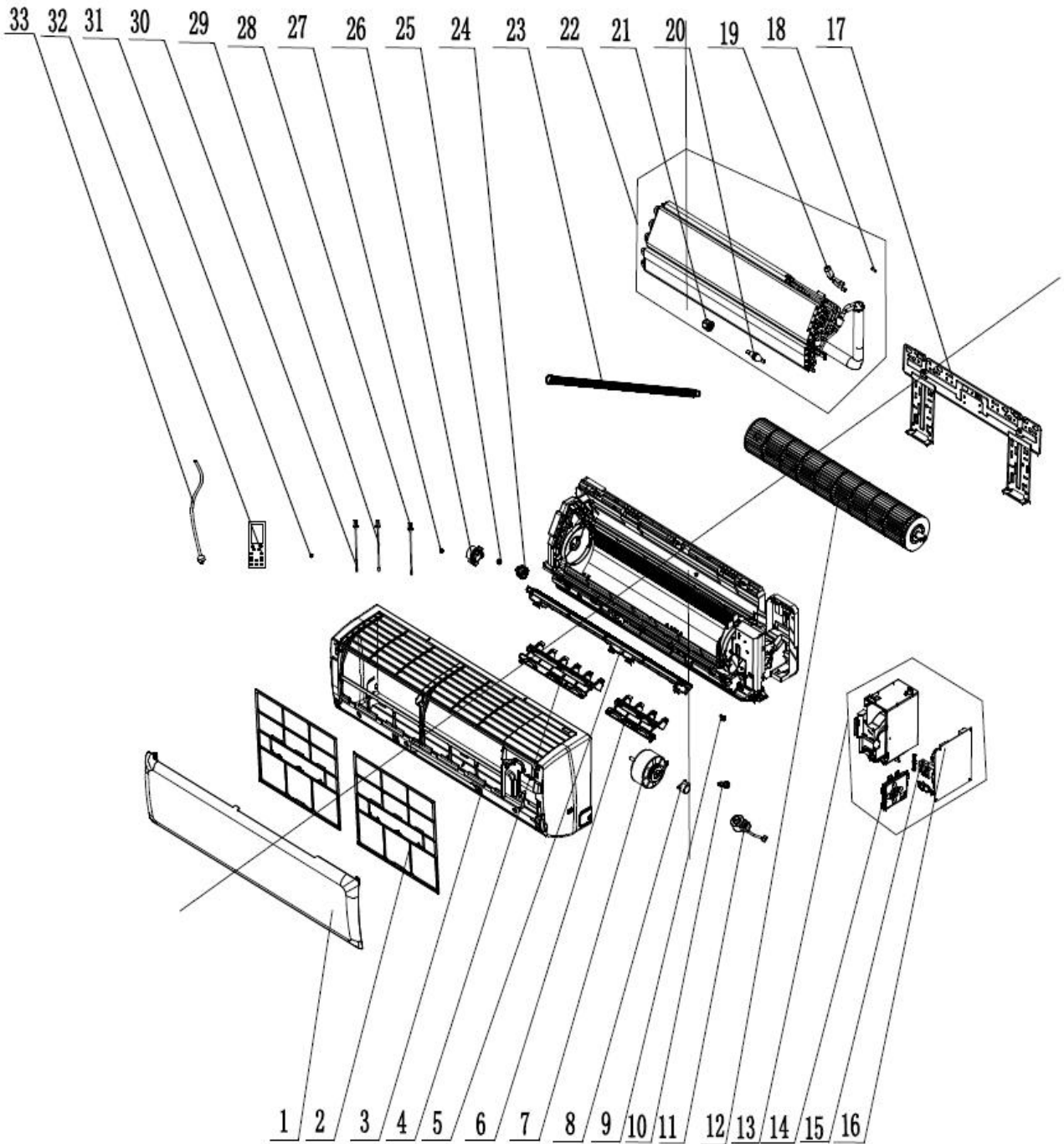

No.	Name of part	For the following unit	
		Unit	Product Code
		GMV-ND56G/C4B-T	CM100N3170
		GMV-ND63G/C4B-T	CM100N3180
		GMV-ND71G/C4B-T	CM100N3190
		Part code	Quantity
1	Front Panel	20000300099S	1
2	Filter Sub-Assy	1101200703	2
3	Front CaseAssy	00000200043	1
4	Air Louver 1	10512737	3
5	Helicoid Tongue	26112513	1
6	Air Louver 2	10512724	0
7	Fan Motor	15012136	1
8	Stepping Motor	1521240212	1
9	Crank	73012005	1
10	Rubber Plug(WaterTray)	76712012	1
11	Electric Expand ValveFitting	4304413216	1
12	Cross Flow Fan	10352057	1
13	Electric Box Assy	100002061356	1
14	Display Board	30565260	1
15	Terminal Board	4201026805	1
16	Main Board	300002060244	1
17	Wall Mounting Frame	01252229	1
18	Filter Sub-Assy	030209060001	1
19	Electronic Expansion Valve	07334466	1
20	Strainer A	0721002201	1
21	Sealing Cap(PressureWarning)	2611219202	1
22	Evaporator Assy	011001060225	1
23	Drainage Hose	05230014	1
24	O-Gasket of Cross FanBearing	76512203	1
25	Fan Bearing	7651221001	1
26	Ring of Bearing	26152025	1
27	Left Axile Bush	10512037	1
28	Temperature Sensor	390000454	1
29	Temperature Sensor	39000076G	1
30	Temperature Sensor	390002072	1
31	Axile Bush	10542036	1
32	Remote Controller	30510589	1
33	Power Cord	4002046417	1

Above data is subject to change without notice,pls reference the SP in global service website.

Exploded View of GMV-ND56G/C2B-T、GMV-ND63G/C2B-T、GMV-ND71G/C2B-T:

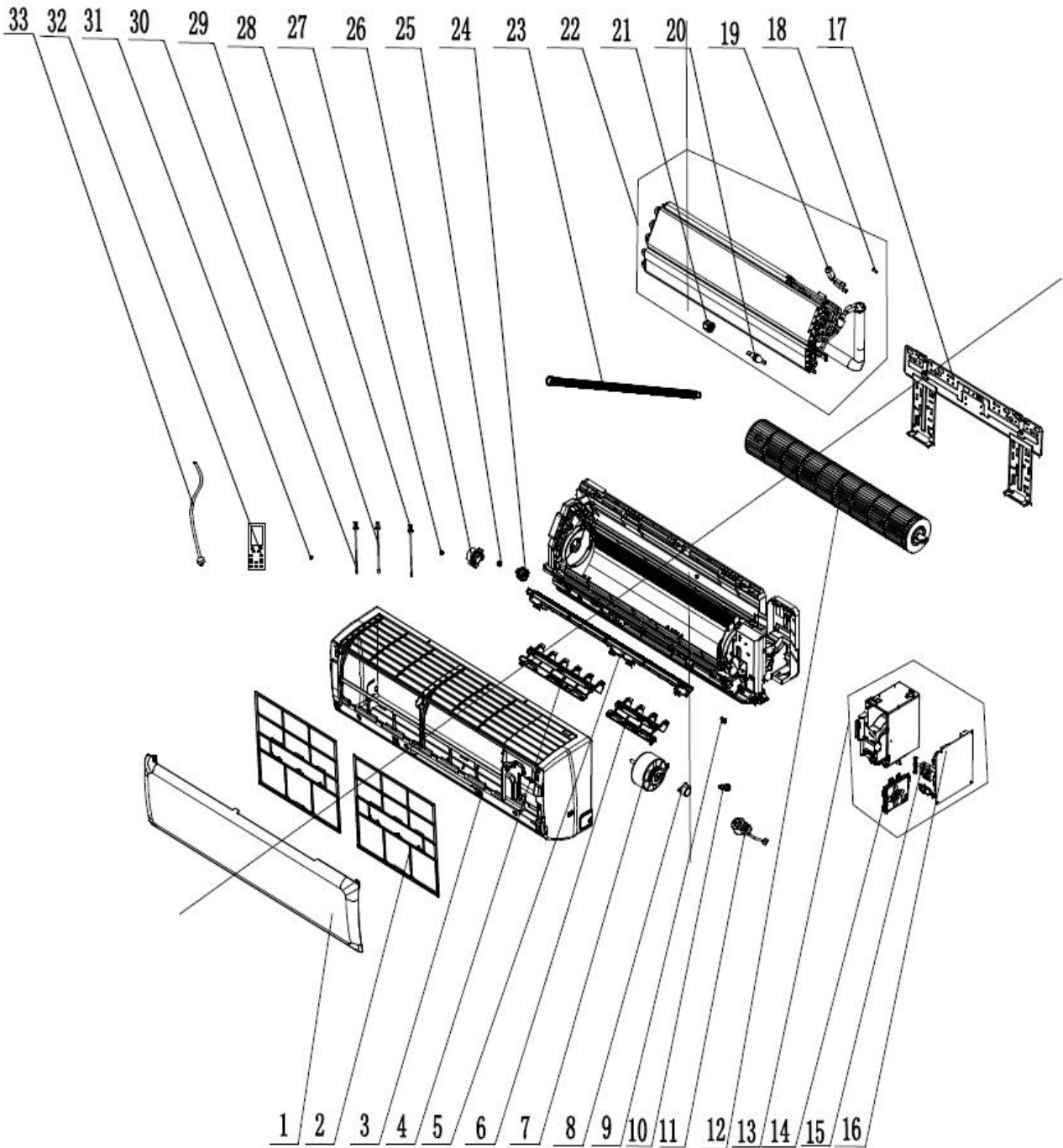

No.	Name of part	For the following unit	
		Unit	Product Code
		GMV-ND56G/C2B-T	CM100N3110
		GMV-ND63G/C2B-T	CM100N3100
		GMV-ND71G/C2B-T	CM100N3090
		Part code	Quantity
1	Front Panel	20000300071S	1
2	Filter Sub-Assy	1101200703	2
3	Front CaseAssy	00000200043	1
4	Air Louver 1	10512737	3
5	Helicoid Tongue	26112513	1
6	Air Louver 2	10512724	0
7	Fan Motor	15012136	1
8	Stepping Motor	1521240212	1
9	Crank	73012005	1
10	Rubber Plug(WaterTray)	76712012	1
11	Electric Expand ValveFitting	4304413216	1
12	Cross Flow Fan	10352057	1
13	Electric Box Assy	100002061356	1
14	Display Board	30565281	1
15	Terminal Board	4201026805	1
16	Main Board	300002060244	1
17	Wall Mounting Frame	01252229	1
18	Filter Sub-Assy	030209060001	1
19	Electronic Expansion Valve	07334466	1
20	Strainer A	0721002201	1
21	Sealing Cap(PressureWarning)	2611219202	1
22	Evaporator Assy	011001060225	1
23	Drainage Hose	05230014	1
24	O-Gasket of Cross FanBearing	76512203	1
25	Fan Bearing	7651221001	1
26	Ring of Bearing	26152025	1
27	Left Axile Bush	10512037	1
28	Temperature Sensor	390000454	1
29	Temperature Sensor	39000076G	1
30	Temperature Sensor	390002072	1
31	Axile Bush	10542036	1
32	Remote Controller	30510589	1
33	Power Cord	4002046417	1

Above data is subject to change without notice,pls reference the SP in global service website.

Exploded View of GMV-ND56G/D2B-T、GMV-ND63G/D2B-T、GMV-ND71G/D2B-T:

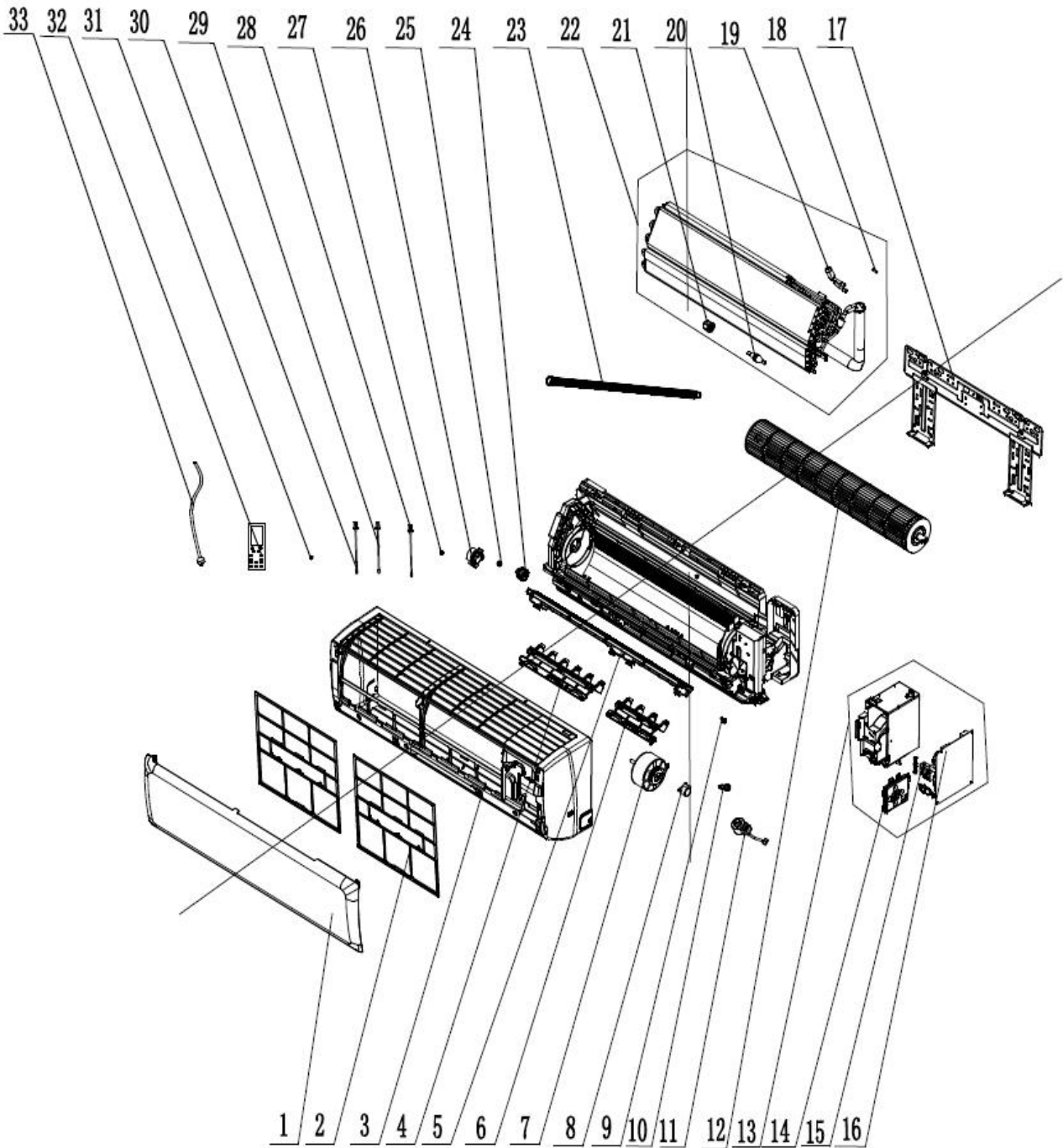

No.	Name of part	For the following unit	
		Unit	Product Code
		GMV-ND56G/D2B-T	CM100N2900
		GMV-ND63G/D2B-T	CM100N2910
		GMV-ND71G/D2B-T	CM100N2920
	Part code	Quantity	
1	Front Panel	0000030023501	1
2	Filter Sub-Assy	1101200703	2
3	Front CaseAssy	0000020017301	1
4	Air Louver 1	10512737	3
5	Helicoid Tongue	26112513	1
6	Air Louver 2	10512724	0
7	Fan Motor	15012136	1
8	Stepping Motor	1521240212	1
9	Crank	73012005	1
10	Rubber Plug(WaterTray)	76712012	1
11	Electric Expand ValveFitting	4304413216	1
12	Cross Flow Fan	10352057	1
13	Electric Box Assy	100002061356	1
14	Display Board	30565260	1
15	Terminal Board	4201026805	1
16	Main Board	300002060244	1
17	Wall Mounting Frame	01252229	1
18	Filter Sub-Assy	030209060001	1
19	Electronic Expansion Valve	07334466	1
20	Strainer A	0721002201	1
21	Sealing Cap(PressureWarning)	2611219202	1
22	Evaporator Assy	011001060225	1
23	Drainage Hose	05230014	1
24	O-Gasket of Cross FanBearing	76512203	1
25	Fan Bearing	7651221001	1
26	Ring of Bearing	26152025	1
27	Left Axile Bush	10512037	1
28	Temperature Sensor	390000454	1
29	Temperature Sensor	39000076G	1
30	Temperature Sensor	390002072	1
31	Axile Bush	10542036	1
32	Remote Controller	30510589	1
33	Power Cord	4002046417	1

Above data is subject to change without notice,pls reference the SP in global service website.

5.14 Super High Static Pressure Duct Type Indoor Unit

Exploded View of GMV-ND22PHS/B-T, GMV-ND25PHS/B-T, GMV-ND28PHS/B-T,
GMV-ND32PHS/B-T, GMV-ND36PHS/B-T:

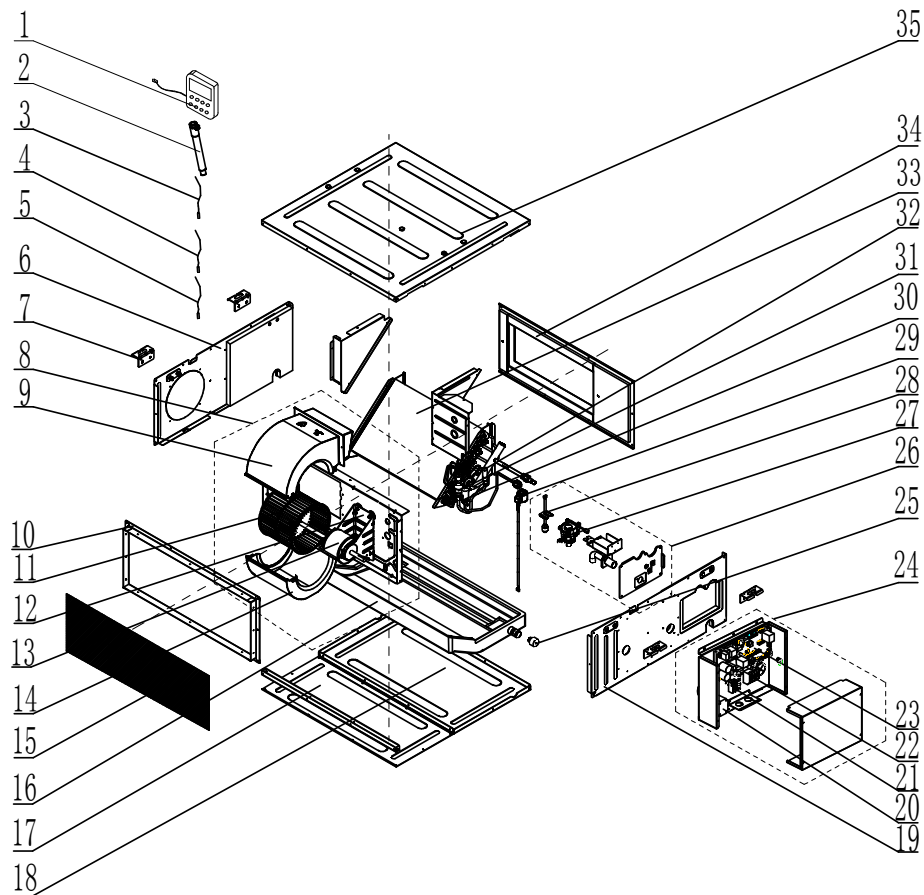

No.	Name of part	For the following unit	
		Unit	Product Code
		GMV-ND22PHS/B-T	CM810N0300
		GMV-ND25PHS/B-T	CM810N0310
		GMV-ND28PHS/B-T	CM810N0320
		GMV-ND32PHS/B-T	CM810N0330
		GMV-ND36PHS/B-T	CM810N0340
		Part code	Quantity
1	Display Board	30296000040	1
2	Drain Hose Sub-Assy	05232050	1
3	Temperature Sensor	390000454	1
4	Temperature Sensor	390000592	1
5	Temperature Sensor	3900005910	1
6	Right Side Plate Assy	01315200148	1
7	Hook	02112466	4
8	Centrifugal Fan Assy	15404100074	1
9	Propeller Housing(Upper)	26905200078	1
10	Return Air Frame Sub-Assy	017026000004	1
11	Centrifugal Fan	10455200003	1
12	Supporter(Fan motor)	0180520027201	1
13	Brushless DC Motor	1570520000501	1
14	Propeller Housing(Lower)	26905200079	1
15	Filter Sub-Assy	111001000055	1

No.	Name of part	For the following unit	
		Unit	Product Code
		GMV-ND22PHS/B-T	CM810N0300
		GMV-ND25PHS/B-T	CM810N0310
		GMV-ND28PHS/B-T	CM810N0320
		GMV-ND32PHS/B-T	CM810N0330
		GMV-ND36PHS/B-T	CM810N0340
		Part code	Quantity
16	Foam Sub-assy	12505200038	1
17	Cover Of Air-In	01265200182	1
18	Bottom Cover Plate	01265200181	1
19	Left Side Plate Assy	01315200147	1
20	Inductance	43128000014	1
21	Terminal Board	4201115402	1
22	Terminal Board	4201800002601	1
23	Main Board	30226000089	1
24	Electric Box Assy	100002000985	1
25	Choke Plug Of Drain Pipe	76815214	2
26	Seal Plate Assy	01495200079	1
27	Water Pump	43138000058	1
28	Water Level Switch	45020216	1
29	Electric Expand Valve Fitting	4304413215	1
30	Strainer	07415210	1
31	Strainer	0741410000601	1
32	Electronic Expansion Valve	07334466	1
33	Evaporator Assy	011001000296 01024100171	1
34	Air Outlet Frame Assy	01374100070	1
35	Top Cover Board Assy	01264100081	1

Above data is subject to change without notice, pls refer the SP in global service website.

Exploded View of GMV-ND40PHS/B-T, GMV-ND45PHS/B-T, GMV-ND50PHS/B-T:

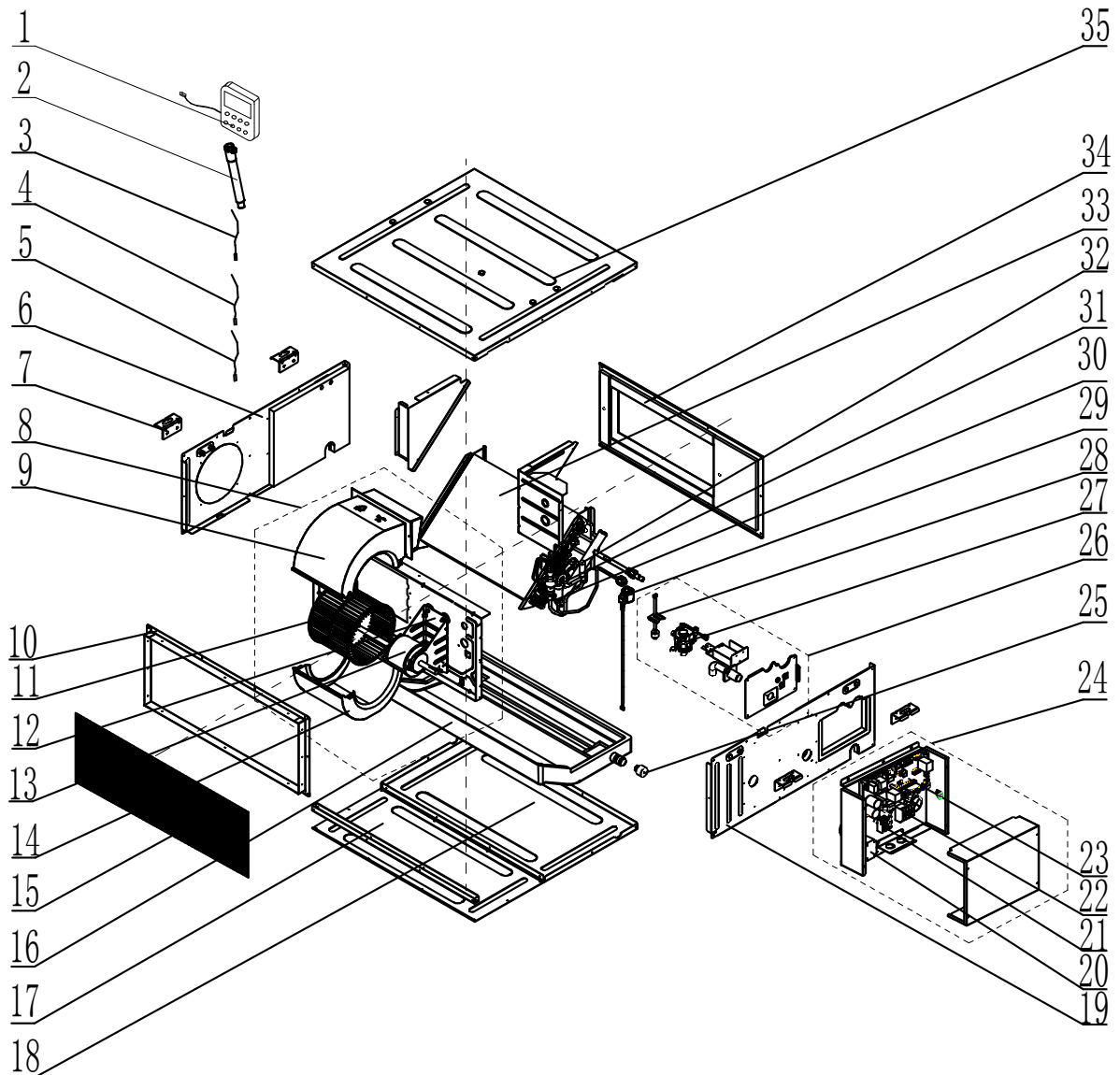

No.	Name of part	For the following unit		
		Unit	Product Code	
			GMV-ND40PHS/B-T	CM810N0350
			GMV-ND45PHS/B-T	CM810N0360
			GMV-ND50PHS/B-T	CM810N0370
	Part code	Quantity		
1	Display Board	30296000040	1	
2	Drain Hose Sub-Assy	05232050	1	
3	Temperature Sensor	390000454	1	
4	Temperature Sensor	390000592	1	
5	Temperature Sensor	3900005910	1	
6	Right Side Plate Assy	01315200148	1	
7	Hook	02112466	4	
8	Centrifugal Fan Assy	15404100074	1	
9	Propeller Housing(Upper)	26905200078	1	
10	Return Air Frame Sub-Assy	017026000004	1	
11	Centrifugal Fan	10455200003	1	
12	Supporter(Fan motor)	0180520027201	1	
13	Brushless DC Motor	1570520000501	1	

No.	Name of part	For the following unit		
		Unit	Product Code	
		GMV-ND40PHS/B-T	CM810N0350	
		GMV-ND45PHS/B-T	CM810N0360	
		GMV-ND50PHS/B-T	CM810N0370	
Part code	Quantity			
14	Propeller Housing(Lower)	26905200079	1	
15	Filter Sub-Assy	111001000055	1	
16	Foam Sub-assy	12505200038	1	
17	Cover Of Air-In	01265200182	1	
18	Bottom Cover Plate	01265200181	1	
19	Left Side Plate Assy	01315200147	1	
20	Inductance	43128000014	1	
21	Terminal Board	4201115402	1	
22	Terminal Board	4201800002601	1	
23	Main Board	30226000089	1	
24	Electric Box Assy	100002000985	1	
25	Choke Plug Of Drain Pipe	76815214	2	
26	Seal Plate Assy	01495200079	1	
27	Water Pump	43138000058	1	
28	Water Level Switch	45020216	1	
29	Electric Expand Valve Fitting	4304413215	1	
30	Strainer	07415210	1	
31	Strainer	0741410000601	1	
32	Electronic Expansion Valve	07334466	1	
33	Evaporator Assy	011001000296 01024100171	1	
34	Air Outlet Frame Assy	01374100070	1	
35	Top Cover Board Assy	01264100081	1	

Above data is subject to change without notice, pls refer the SP in global service website.

Exploded View of GMV-ND56PHS/B-T, GMV-ND63PHS/B-T, GMV-ND71PHS/B-T,
GMV-ND80PHS/B-T:

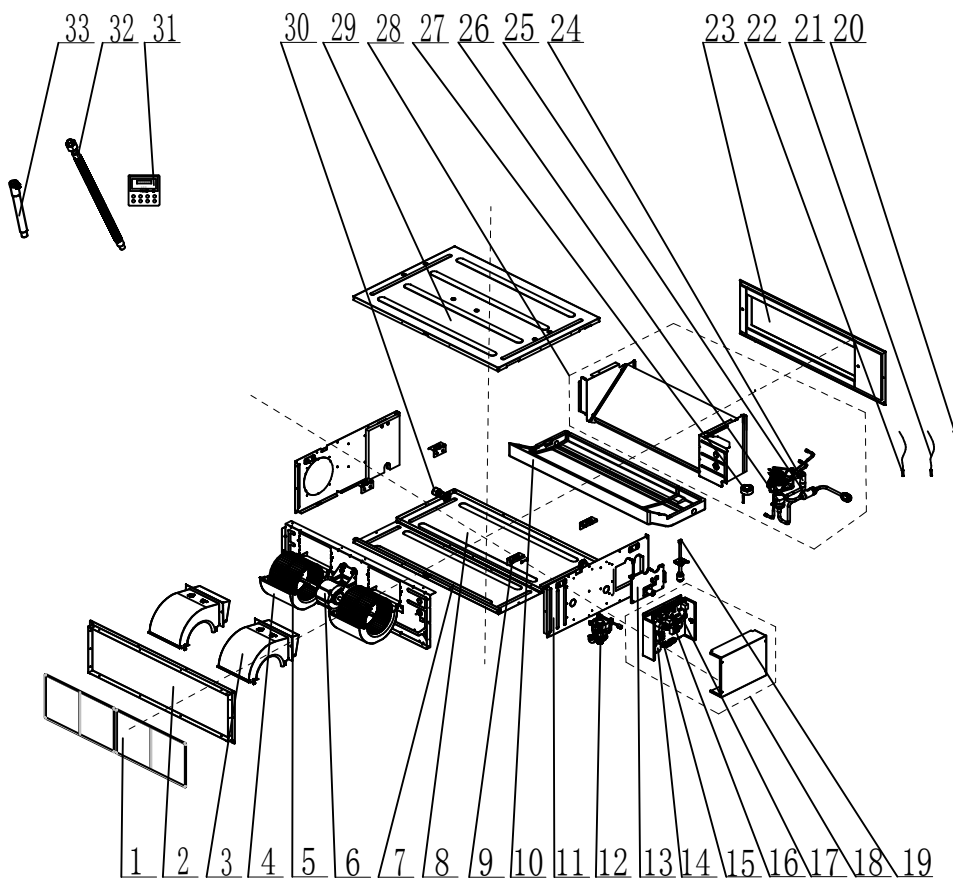

No.	Name of part	For the following unit	
		Unit	Product Code
		GMV-ND56PHS/B-T	CM810N0380
		GMV-ND63PHS/B-T	CM810N0390
		GMV-ND71PHS/B-T	CM810N0400
		GMV-ND80PHS/B-T	CM810N0410
		Part code	Quantity
1	Centrifugal Fan Assy	017026000002	1
2	Filter Sub-Assy	111001000045	2
3	Propeller Housing(Upper)	26905200078	2
4	Centrifugal Fan	10455200003	2
5	Brushless DC Motor	15705200016	1
6	Propeller Housing(Lower)	26905200079	2
7	Blower Mounting Plate Sub-Assy	01325200079	1
8	Cover Of Air-In	01265200132	1
9	Hook	02112466	4
10	Bottom Cover Plate	01265200131	1
11	Seal plate Assy	01495200079	1
12	Water Level Switch	45020216	1
13	Water Pump	43138000058	1
14	Left Side Plate Assy	01315200147	1
15	Electric Box Assy	100002000985	1
16	Inductance	43128000014	1
17	Terminal Board	4201115402	1
18	Main Board	30226000089	1

No.	Name of part	For the following unit	
		Unit	Product Code
		GMV-ND56PHS/B-T	CM810N0380
		GMV-ND63PHS/B-T	CM810N0390
		GMV-ND71PHS/B-T	CM810N0400
		GMV-ND80PHS/B-T	CM810N0410
		Part code	Quantity
19	Terminal Board	4201800002601	1
20	Air Outlet Frame Assy	01375200026	1
21	Evaporator Assy	01024100173 0102410017301	1
22	Sealing Cap(Pressure Warning)	2611219201	1
23	Electric Expand Valve Fitting	4304413215	1
24	Electronic Expansion Valve	07334466	1
25	Strainer	0741410000601	1
26	Strainer	07415210	1
27	Choke Plug of Drain Pipe	76815214	2
28	Foam Sub-assy	12505200025	1
29	Top Cover Board Assy	01265200130	1
30	Temperature Sensor	3900005910	1
31	Temperature Sensor	390000592	1
32	Temperature Sensor	390000454	1
33	Display Board	30296000040	1
34	Corrugated Pipe	05015408	1
35	Drain Hose Sub-Assy	05232050	1

Above data is subject to change without notice, pls refer the SP in global service website.

Exploded View of GMV-ND90PHS/B-T, GMV-ND100PHS/B-T, GMV-ND112PHS/B-T, GMV-ND125PHS/B-T:

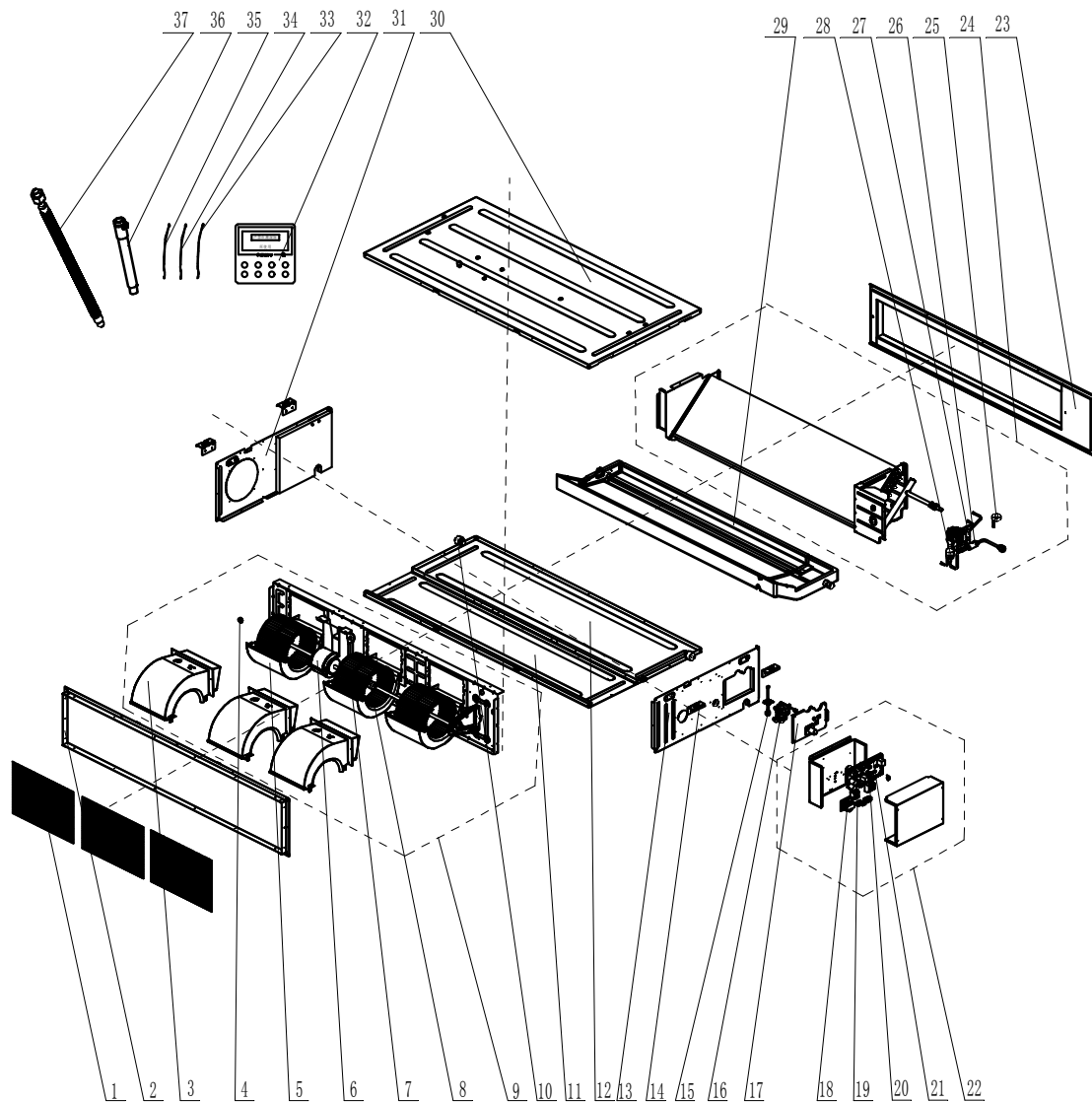

No.	Name of part	For the following unit	
		Unit	Product Code
		GMV-ND90PHS/B-T	CM810N0420
		GMV-ND100PHS/B-T	CM810N0430
		GMV-ND112PHS/B-T	CM810N0440
		GMV-ND125PHS/B-T	CM810N0450
		Part code	Quantity
1	Filter Sub-Assy	111001000052	3
2	Return Air Frame Sub-Assy	017026000003	1
3	Propeller Housing(Upper)	26905200078	3
4	Fan Bearing	76512210	1
5	Propeller Housing(Lower)	26905200079	3
6	Brushless DC Motor	1570940000601	1
7	Centrifugal Fan	10455200003	3
8	Joint Slack	73018731	1
9	Centrifugal Fan Assy	000052000028	1
10	Choke Plug Of Drain Pipe	76815214	2
11	Cover Plate(Air Return)	01265200123	1
12	Bottom Cover Plate	01265200125	1

No.	Name of part	For the following unit	
		Unit	Product Code
		GMV-ND90PHS/B-T	CM810N0420
		GMV-ND100PHS/B-T	CM810N0430
		GMV-ND112PHS/B-T	CM810N0440
		GMV-ND125PHS/B-T	CM810N0450
		Part code	Quantity
13	Left Side Plate Assy	01315200147	1
14	Hook	02112466	4
15	Water Level Switch	45020216	1
16	Water Pump	43138000058	1
17	Seal Plate	01495200078	1
18	Reactor	43138000047	1
19	Terminal board	4201115402	1
20	Terminal Board	4201800002601	1
21	Main Board	300002000009	1
22	Electric Box Assy	100002000984	1
23	Air Outlet Frame Assy	01375200023	1
24	Evaporator Assy	011001000070	1
25	Electric Expand Valve Fitting	4304413215	1
26	Strainer	0741410000601	1
27	Electronic Expansion Valve	07334468	1
28	Strainer	07415210	1
29	Foam Sub-Assy	12505200021	1
30	Top Cover Board Assy	01264100105	1
31	Right Side Plate Assy	01315200148	1
32	Display Board	30296000040	1
33	Temperature Sensor	3900005910	1
34	Temperature Sensor	390000592	1
35	Temperature Sensor	390000454	1
36	Drain Hose Sub-Assy	05232050	1
37	Corrugated Pipe	05015408	1

Above data is subject to change without notice, pls refer the SP in global service website.

Exploded View of GMV-ND140PHS/B-T, GMV-ND160PHS/B-T

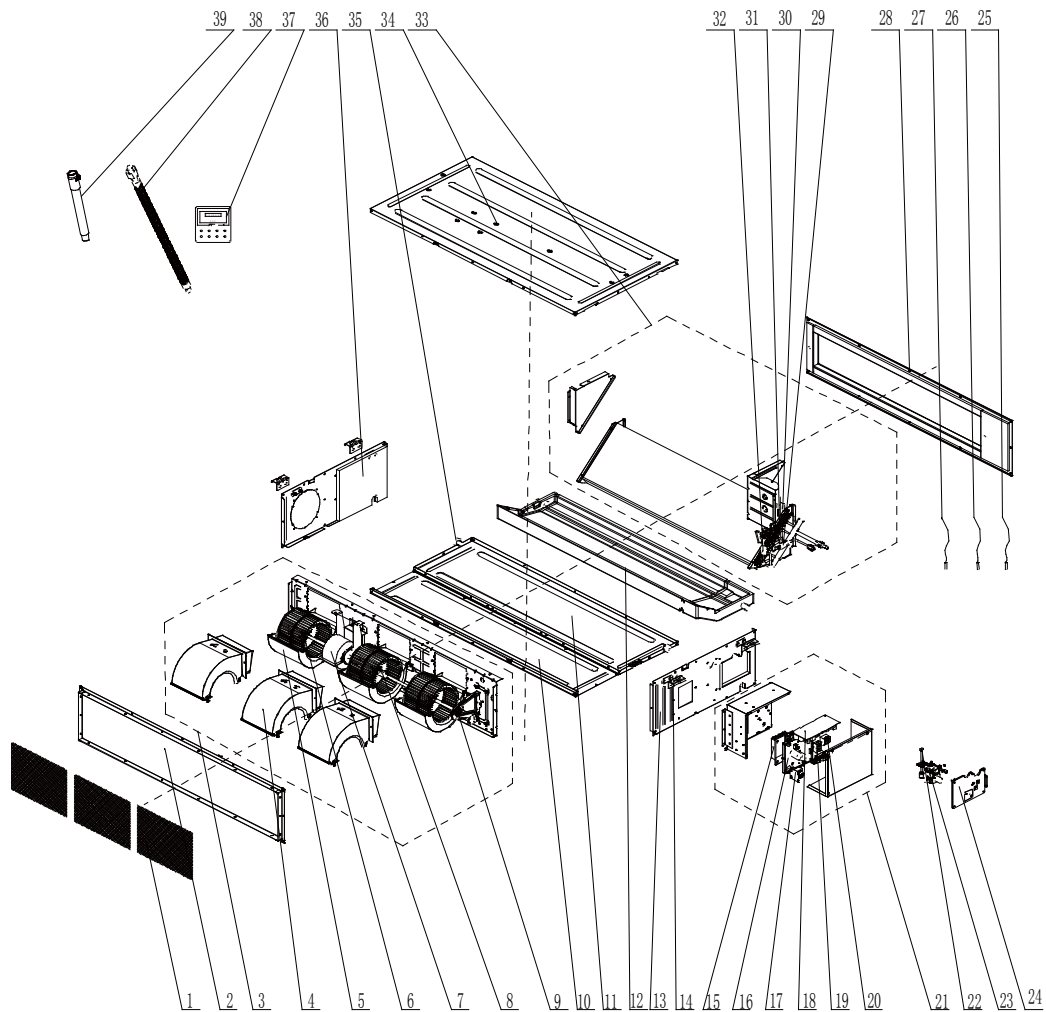

No.	Name of part	For the following unit	
		Unit	Product Code
		GMV-ND140PHS/B-T	CM810N0460
		GMV-ND160PHS/B-T	CM810N0840
		Part code	Quantity
1	Filter Sub-Assy	111001000052	3
2	Return Air Frame Sub-Assy	017026000003	1
3	Centrifugal Fan Assy	000052000029	1
4	Propeller Housing(Upper)	269052000078	3
5	Propeller Housing(Lower)	269052000079	3
6	Centrifugal Fan	104552000003	3
7	Brushless DC Motor	1570940000801	1
8	Joint Slack	73018731	1
9	Fan Bearing	7651221001	1
10	Cover Plate(Air return)	01265200123	1
11	Bottom Cover Plate	01265200125	1
12	Foam Sub-Assy(Water Tray)	125052000021	1
13	Left Side Plate Assy	01314100118	1
14	Hook	02112466	4
15	Radiator	49018000068	1
16	Main Board	30221000033	1
17	Reactor	43138000047	1
18	Main Board	30226000092	1

No.	Name of part	For the following unit	
		Unit	Product Code
		GMV-ND140PHS/B-T	CM810N0460
		GMV-ND160PHS/B-T	CM810N0840
		Part code	Quantity
19	Terminal board	42000100000101	1
20	Terminal Board	4201800002601	1
21	Electric Box Assy	100002001967	1
22	Water Level Switch	45020216	1
23	Water Pump	43138000058	1
24	Seal Plate	01495200078	1
25	Temperature Sensor	3900005910	1
26	Temperature Sensor	390000592	1
27	Temperature Sensor	390000454	1
28	Air Outlet Frame Assy	01375200023	1
29	Strainer	0741410000601	1
30	Electric Expand Valve Fitting	4304413215	1
31	Electronic Expansion Valve	07334468	1
32	Strainer	07415210	1
33	Evaporator Assy	011001000070 011001000238	1
34	Top Cover Board Assy	01264100105	1
35	Choke Plug Of Drain Pipe	76815214	2
36	Right Side Plate Assy	01315200148	1
37	Display Board	30296000040	1
38	Corrugated Pipe	05015408	1
39	Drain Hose Sub-Assy	05232050	1

Above data is subject to change without notice, pls reference the SP in global service website.

Exploded View of GMV-ND180PHS/B-T

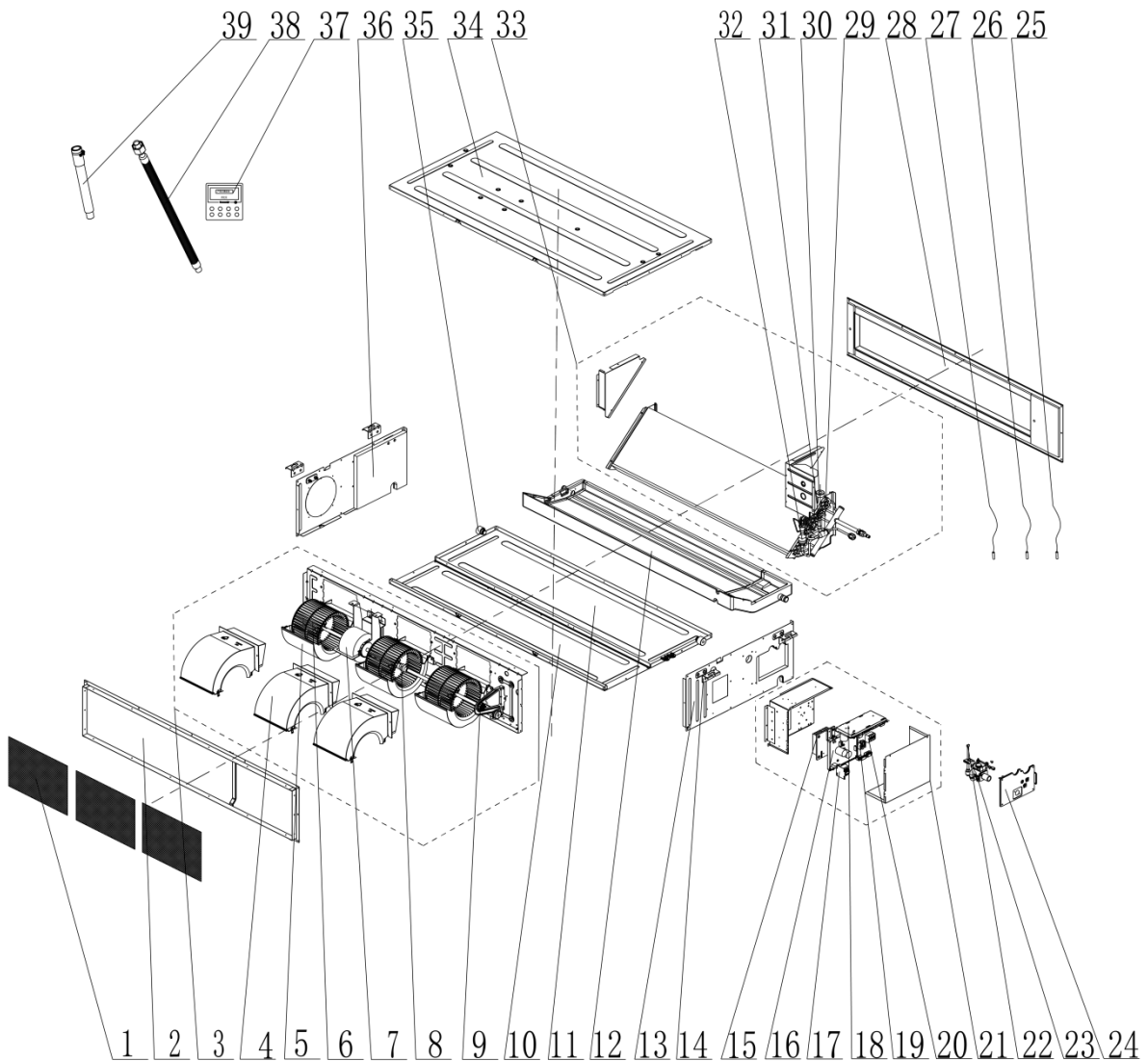

No.	Name of part	For the following unit	
		Unit	Product Code
		GMV-ND180PHS/B-T	CM810N2240
		Part code	Quantity
1	Filter Sub-Assy	111001000052	3
2	Return Air Frame Sub-Assy	017026000003	1
3	Centrifugal fan assy	000052000029	1
4	Propeller Housing(Upper)	269052000078	3
5	Propeller Housing(Lower)	269052000079	3
6	Centrifugal Fan	104552000003	3
7	Brushless DC Motor	1570940000801	1
8	Joint Slack	73018731	1
9	Fan Bearing	7651221001	1
10	Cover Plate(Air return)	01265200123	1
11	Bottom Cover Plate	01265200125	1
12	Foam Sub-assy	125052000021	1
13	Left Side Plate Assy	01314100118	1
14	Hook	02112466	4
15	Radiator	49018000068	1
16	Main Board	30221000033	1

No.	Name of part	For the following unit	
		Unit	Product Code
		GMV-ND180PHS/B-T	CM810N2240
		Part code	Quantity
17	Reactor	43138000047	1
18	Main Board	300002061641	1
19	Terminal Board	42000100000101	1
20	Terminal Board	42200006000401	1
21	Electric Box Assy	100002070712	1
22	Water Level Switch	4502021603	1
23	Water Pump	43138000058	1
24	Seal plate	01495200078	1
25	Temperature Sensor	3900005910	1
26	Temperature Sensor	390000592	1
27	Temperature Sensor	390000454	1
28	Air Outlet Frame Assy	01375200023	1
29	Strainer	0741410000601	1
30	Electric Expand Valve Fitting	4304413253	1
31	Electronic Expansion Valve	07334468	1
32	Strainer	07415210	1
33	Evaporator Assy	011001000237	1
34	Top Cover Board Assy	01264100105	1
35	Choke Plug of Drain Pipe	76815214	2
36	Right Side Plate Assy	01315200148	1
37	Display Board	30296000040	1
38	Corrugated Pipe	035030000005	1
39	Drain Hose Sub-Assy	05232050	1

Above data is subject to change without notice, pls reference the SP in global service website.

Exploded View of GMV-ND400PH/AR-X and GMV-ND450PH/AR-X:

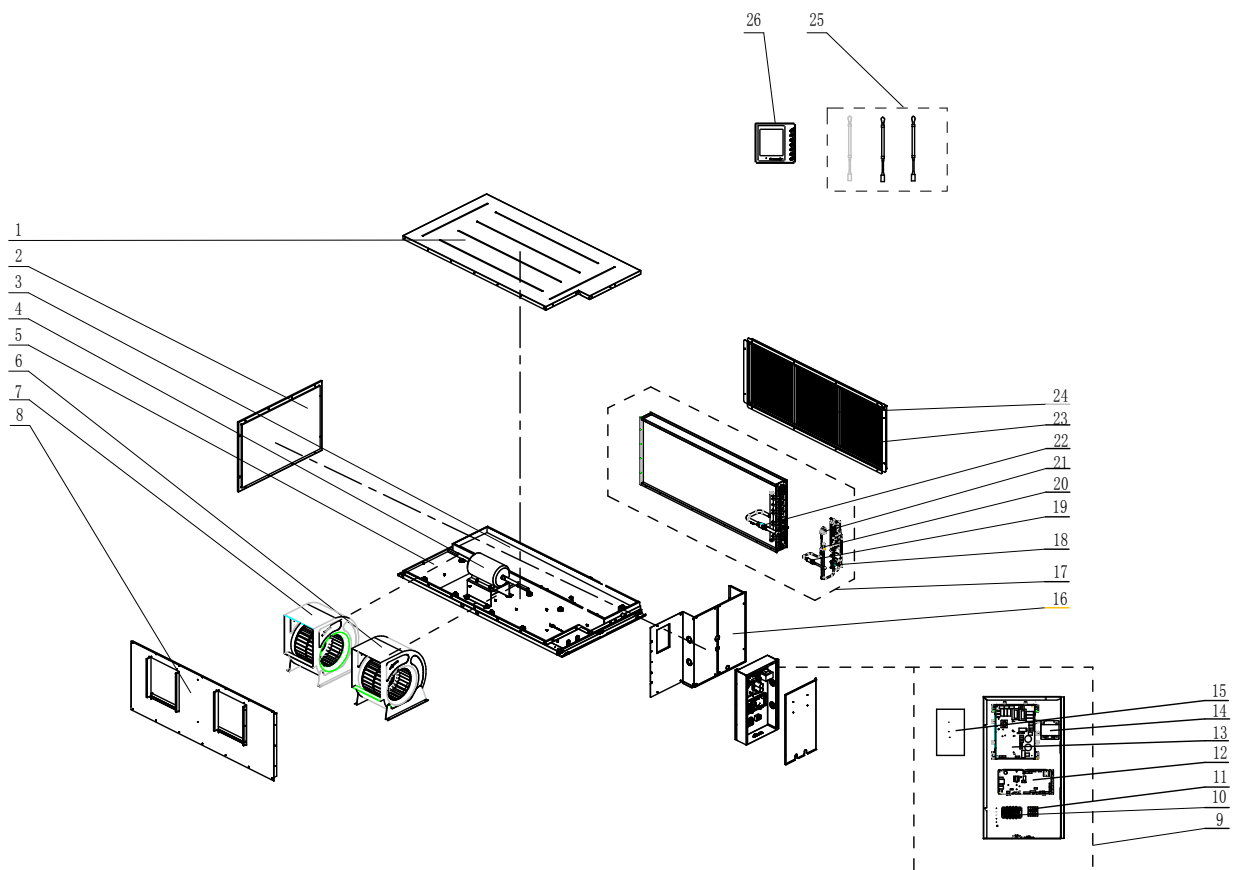

No.	Name of part	For the following unit	
		Unit	Product Code
		GMV-ND400PH/AR-X	CM810N1510
		GMV-ND450PH/AR-X	CM810N1520
		Part code	Quantity
1	Top Cover Board Sub-assy	017011000039	1
2	Left Side Plate Assy	000080000020	1
3	Water Collecting Tray Assy	00707000000201	1
4	Brushless DC Motor	150104000015	1
5	Hange Frame Assy	000249000001	1
6	Motor for Centrifugal Fan	103004000048	1
7	Motor for Centrifugal Fan	10300400004801	1
8	Air Outlet Panel Sub-assy	000040000029	1
9	Electric Box Assy	100002004015	1
10	Terminal Board	42000100000401	1
11	Terminal Board	4201800002601	1
12	Main Board	30226000092	1
13	Main Board	300002000380	1
14	Reactor	43130189	1
15	Radiator	49018000013	1
16	Right Side Plate Assy	000081000031	1
17	Evaporator Assy	011001000626	1
18	Strainer	07415210	1
19	Bidirection Strainer	07220016	1

No.	Name of part	For the following unit	
		Unit	Product Code
		GMV-ND400PH/AR-X	CM810N1510
		GMV-ND450PH/AR-X	CM810N1520
		Part code	Quantity
20	Electronic Expansion Valve	43044100190	1
21	Electric Expand Valve Fitting	4304413252	1
22	Filter	07219056	1
23	Filter Sub-assy 1	11129078	2
24	Filter Sub-assy 2	11129079	1
25	Sens or Sub-assy	39008000103G	1
26	Display Board	30296000040	1

Above data is subject to change without notice,pls reference the SP in global service website.

Exploded View of GMV-N560PH/AR-M:

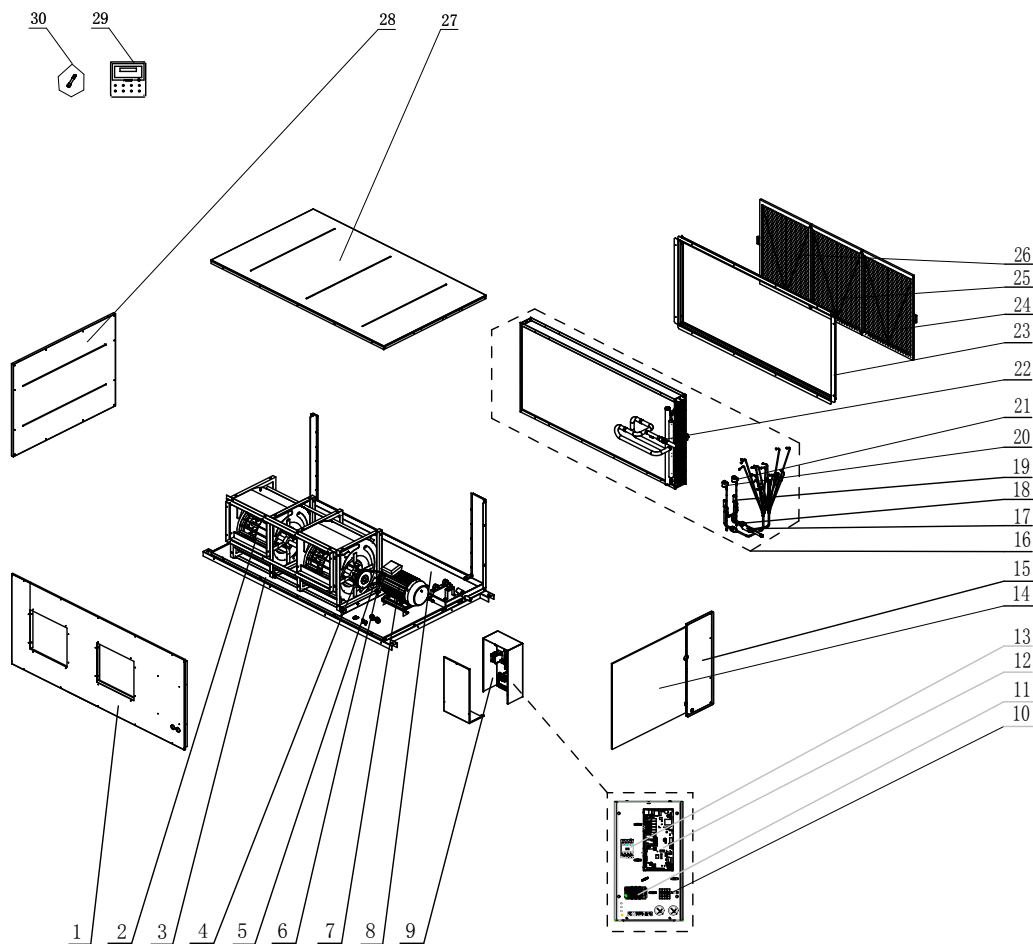

No.	Name of part	For the following unit	
		Unit	Product Code
		GMV-N560PH/AR-M	CM810N1610
		Part code	Quantity
1	Air Outlet Panel Assy	01545317	1
2	Blower	15019241	1
3	Base Frame Assy	000043060052	1
4	Belt Wheel	10548156	1
5	Belt	76318356	2

No.	Name of part	For the following unit	
		Unit	Product Code
		GMV-N560PH/AR-M	CM810N1610
		Part code	Quantity
6	Belt Wheel	10548150	1
7	Fan Motor	150101000061	1
8	Water Collecting Tray Assy	007070060001	1
9	Electric Box Assy	100002060437	1
10	Terminal Board	4201800002601	1
11	Terminal Board	42010052	1
12	Main Board	30226232	1
13	A C Contactor	44010287	1
14	Front Panel Sub-assy	209004060007	1
15	Front Panel Sub-assy	209004060006	1
16	Evaporator Assy	011001060073	1
17	Gas Tube Filter	072190511	1
18	Strainer	07415210	2
19	Electronic Expansion Valve	43044100173	1
20	Electric Expand Valve Fitting	4304413219	1
21	Electric Expand Valve Fitting	4304413220	1
22	Filter	07219056	1
23	Return Air Frame Assy	01375208P	2
24	Filter Sub-assy 1	11129080	1
25	Filter Sub-assy 2	11129081	1
26	Filter Sub-assy 3	11129082	1
27	Top Cover Sub-assy	01265321	1
28	Side Panel Sub-assy 1	01545311	1
29	Display Board	30296000040	1
30	Sensor Sub-assy	390002060003	1

Above data is subject to change without notice,pls reference the SP in global service website.

5.15 AHU-KIT Type

Exploded View of GMV-N36U/A-T, GMV-N71U/A-T, GMV-N140U/A-T, GMV-N280U/A-T,:

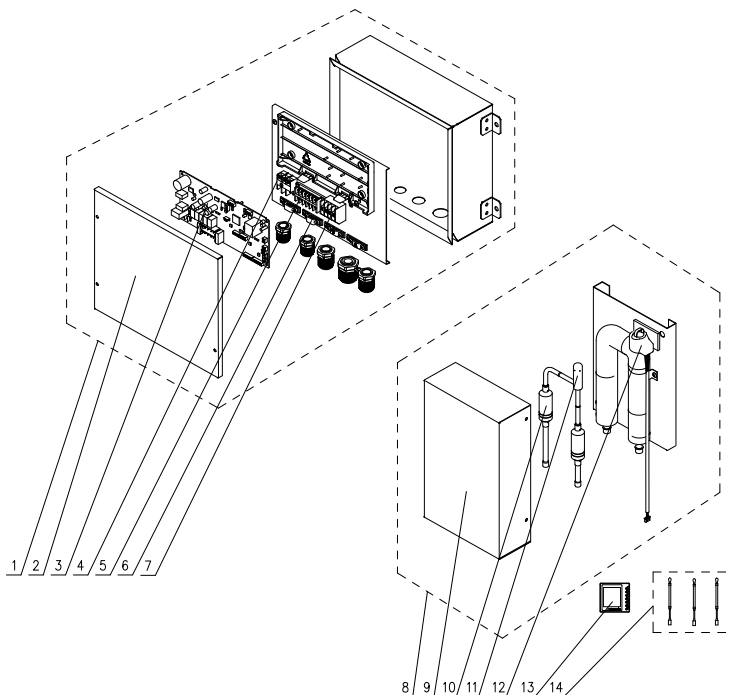

GMV-N36U/A-T:

NO.	Model	GMV-N36U/A-T	Qty.
	Product Code	CN750N0040	
	Part Name	Part Code	
1	Electric Box Assy	10002001936	1
2	Electric Box Cover	01424100135P	1
3	Main Board	30226000081	1
4	Terminal Board	42010259	1
5	Terminal Board	42011117	1
6	Wire Clamp	71010003	2
7	Terminal Board	420180002601	1
8	Electronic Expansion Valve assy	030174000026	1
9	Cover Plate	01264100061P	1
10	Bidirection Strainer	07220016	2
11	Electronic Expansion Valve	07334463	1
12	Electric Expand Valve Fitting	4304413239	1
13	Display Board	30296000040	1
14	Sensor Sub-assy	39008000130G	1

GMV-N71U/A-T:

NO.	Model	GMV-N71U/A-T	Qty.
	Product Code	CN750N0050	
	Part Name	Part Code	
1	Electric Box Assy	10002001936	1
2	Electric Box Cover	01424100135P	1
3	Main Board	30226000081	1
4	Terminal Board	42010259	1
5	Terminal Board	42011117	1

NO.	Model	GMV-N71U/A-T	Qty.
	Product Code	CN750N0050	
	Part Name	Part Code	
6	Wire Clamp	71010003	2
7	Terminal Board	4201800002601	1
8	Electronic Expansion Valve assy	030174000027	1
9	Cover Plate	01264100061P	1
10	Bidirection Strainer	07220016	2
11	Electronic Expansion Valve	07334466	1
12	Electric Expand Valve Fitting	4304413239	1
13	Display Board	0296000040	1
14	Sensor Sub-assy	39008000130G	1

GMV-N140U/A-T:

NO.	Model	GMV-N140U/A-T	Qty.
	Product Code	CN750N0030	
	Part Name	Part Code	
1	Electric Box Assy	100002001936	1
2	Electric Box Cover	01424100135P	1
3	Main Board	30226000081	1
4	Terminal Board	42010259	1
5	Terminal Board	42011117	1
6	Wire Clamp	71010003	2
7	Terminal Board	4201800002601	1
8	Electronic Expansion Valve assy	43044100226	1
9	Cover Plate	01264100061P	1
10	Bidirection Strainer	07220016	2
11	Electronic Expansion Valve	07334412	1
12	Electric Expand Valve Fitting	4304413239	1
13	Display Board	30296000040	1
14	Sensor Sub-assy	39008000130G	1

GMV-N280U/A-T:

NO.	Model	GMV-N280U/A-T	Qty.
	Product Code	CN750N0020	
	Part Name	Part Code	
1	Electric Box Assy	100002001936	1
2	Electric Box Cover	01424100135P	1
3	Main Board	30226000081	1
4	Terminal Board	42010259	1
5	Terminal Board	42011117	1
6	Wire Clamp	71010003	2
7	Terminal Board	4201800002601	1
8	Electronic Expansion Valve assy	43044100215	1
9	Cover Plate	01264100061P	1
10	Bidirection Strainer	07220016	2
11	Electronic Expansion Valve	07331139	1
12	Electric Expand Valve Fitting	4304413239	1
13	Display Board	30296000040	1
14	Sensor Sub-assy	39008000130G	1

Above data is subject to change without notice, pls refer the SP in global service website.

Exploded View of GMV-N36U/B-T, GMV-N71U/B-T, GMV-N140U/B-T, GMV-N280U/B-T:

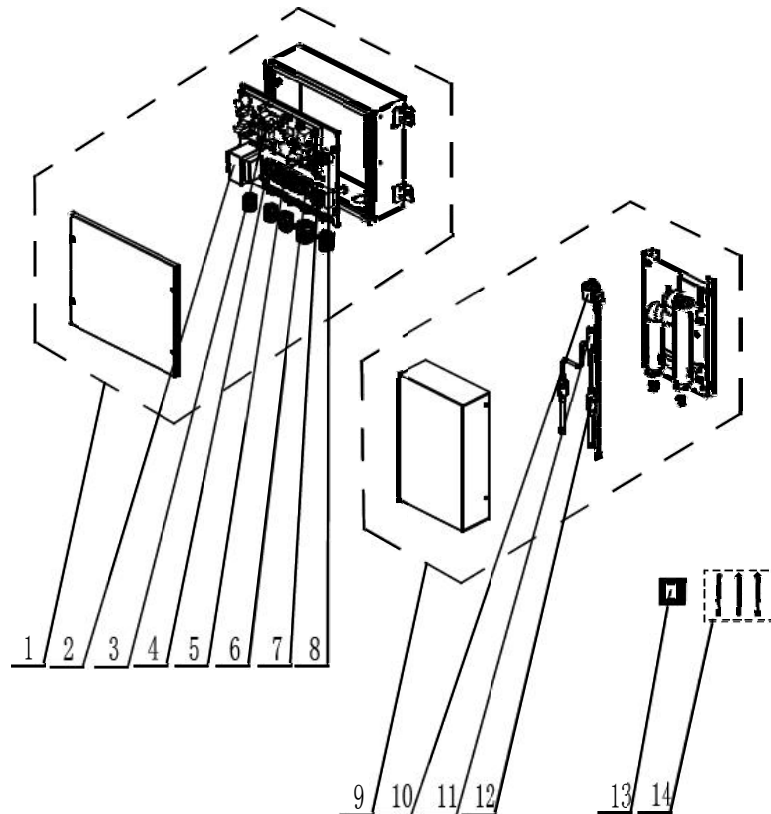

GMV-N36U/B-T:

NO.	Model	GMV-N36U/B-T	Qty.
	Product Code	CN750N0110	
	Part Name	Part Code	
1	Electric Box Assy	100002060732	1
2	Transformer	43110286	1
3	Main Board	30226000081	1
4	Terminal Board	42000100000101	1
5	Terminal Board	422000000025	1
6	Terminal Board	420001000001	1
7	Terminal Board	4201800002601	1
8	Terminal Board	42011147	1
9	Electronic Expansion Valve Assy	030174060015	1
10	Electric Expand Valve Fitting	4304000112	1
11	Electronic Expansion Valve	072009000006	1
12	Strainer	07415200002	2
13	Display Board	30296000040	1
14	Sensor Sub-assy	390002060021	1

GMV-N71U/B-T:

NO.	Model	GMV-N71U/B-T	Qty.
	Product Code	CN750N0150	
	Part Name	Part Code	
1	Electric Box Assy	100002060732	1
2	Transformer	43110286	1
3	Main Board	30226000081	1
4	Terminal Board	42000100000101	1
5	Terminal Board	422000000025	1

NO.	Model	GMV-N71U/B-T	Qty.
	Product Code	CN750N0150	
	Part Name	Part Code	
6	Terminal Board	420001000001	1
7	Terminal Board	4201800002601	1
8	Terminal Board	42011147	1
9	Electronic Expansion Valve assy	030174060014	1
10	Electric Expand Valve Fitting	4304413239	1
11	Electronic Expansion Valve	072009000001	1
12	Strainer	0741520000201	2
13	Display Board	30296000040	1
14	Sensor Sub-assy	390002060021	1

GMV-N140U/B-T:

NO.	Model	GMV-N140U/B-T	Qty.
	Product Code	CN750N0140	
	Part Name	Part Code	
1	Electric Box Assy	100002060732	1
2	Transformer	43110286	1
3	Main Board	30226000081	1
4	Terminal Board	42000100000101	1
5	Terminal Board	422000000025	1
6	Terminal Board	420001000001	1
7	Terminal Board	4201800002601	1
8	Terminal Board	42011147	1
9	Electronic Expansion Valve assy	030174060012	1
10	Electric Expand Valve Fitting	4304413239	1
11	Electronic Expansion Valve	43044100172	1
12	Strainer	0741520000201	2
13	Display Board	30296000040	1
14	Sensor Sub-assy	390002060021	1

GMV-N280U/B-T:

NO.	Model	GMV-N280U/B-T	Qty.
	Product Code	CN750N0120	
	Part Name	Part Code	
1	Electric Box Assy	100002060732	1
2	Transformer	43110286	1
3	Main Board	30226000081	1
4	Terminal Board	42000100000101	1
5	Terminal Board	422000000025	1
6	Terminal Board	420001000001	1
7	Terminal Board	4201800002601	1
8	Terminal Board	42011147	1
9	Electronic Expansion Valve assy	030174060013	1
10	Electric Expand Valve Fitting	4304413239	1
11	Electronic Expansion Valve	43044100190	1
12	Strainer	0741520000201	2
13	Display Board	30296000040	1
14	Sensor Sub-assy	390002060021	1

Above data is subject to change without notice, pls refer the SP in global service website.

Exploded View of GMV-N560U/B-T:

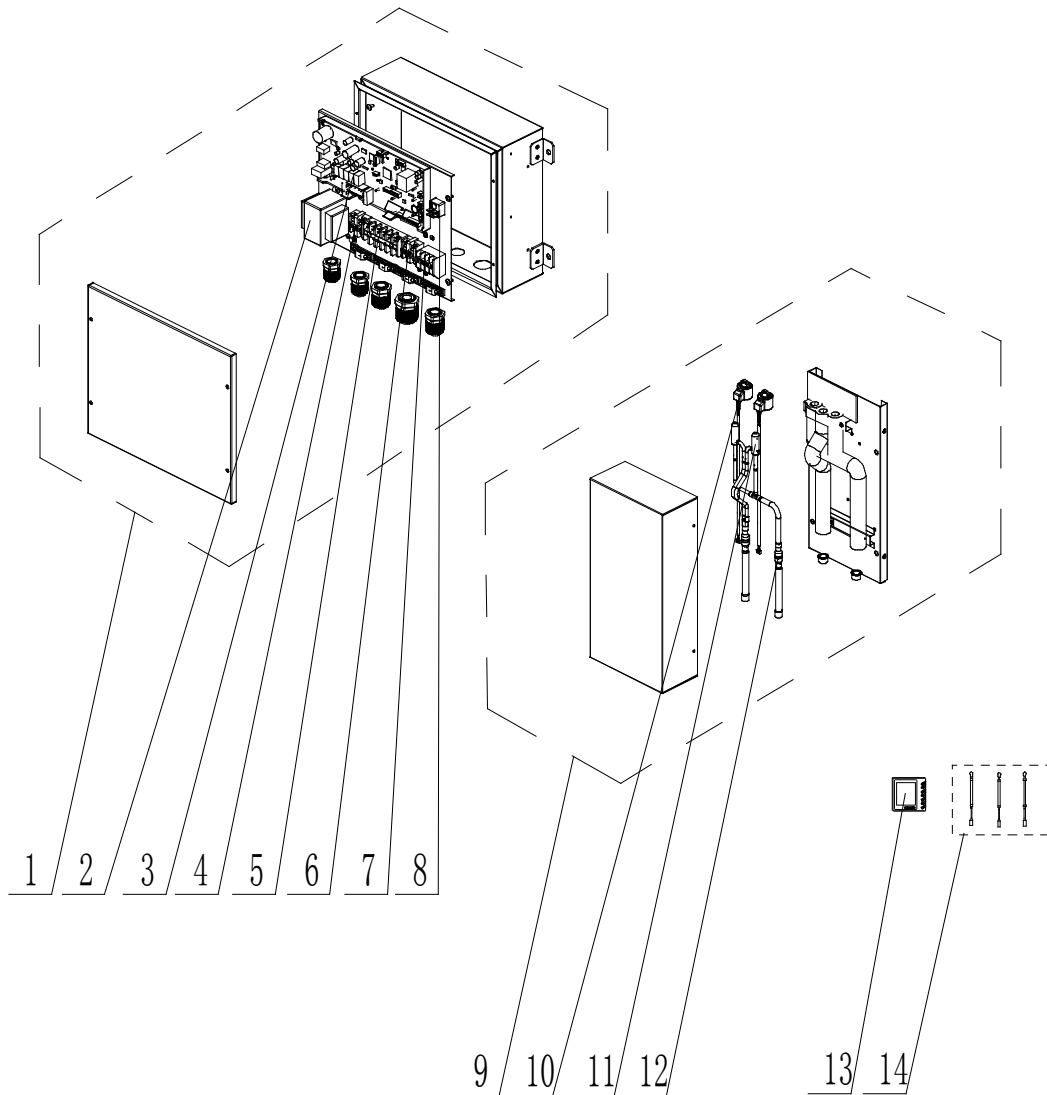

NO.	Model	GMV-N560U/B-T	Qty.
	Product Code	CN750N0130	
	Part Name	Part Code	
1	Electric Box Assy	10002060732	1
2	Transformer	43110286	1
3	Main Board	30226000081	1
4	Terminal Board	42000100000101	1
5	Terminal Board	422000000025	1
6	Terminal Board	420001000001	1
7	Terminal Board	4201800002601	1
8	Terminal Board	42011147	1
9	Electronic Expansion Valve assy	030174060011	1
10	Electric Expand Valve Fitting	4304413239	2
11	Electronic Expansion Valve	43044100190	2
12	Strainer	0721212101	2
13	Display Board	30296000040	1
14	Sensor Sub-assy	390002060021	1

Above data is subject to change without notice, pls refer the SP in global service website.

Exploded View of GMV-N36U/C-T:

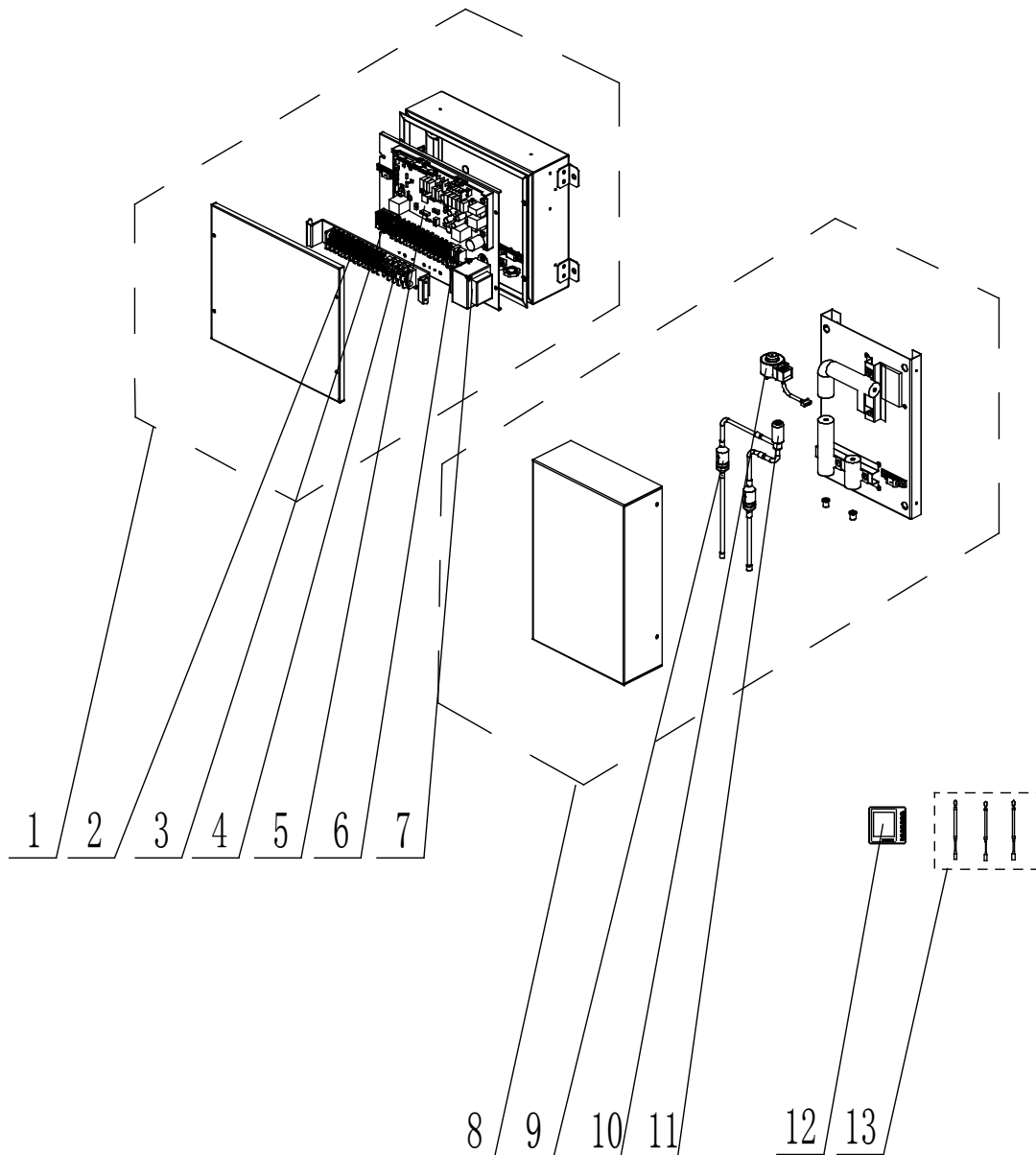

NO.	Model	GMV-N36U/C-T	Qty.
	Product Code	CN750N0190	
	Part Name	Part Code	
1	Electric Box Assy	'100002066409	1
2	Terminal Board	'422000000009	2
3	Terminal Board	'42200006000401	1
4	Terminal Board	'42200006000901	1
5	Main Board	'300002060941	1
6	Terminal Board	'42000100000101	1
7	Transformer	'450002060013	1
8	Electronic Expansion Valve Assy	'030174060015	1
9	Electric Expand Valve Fitting	'4304413239	2
10	Electronic Expansion Valve	'4304000112	1
11	Strainer	'072009000006	1
12	Display Board	'30296000040	1
13	Sensor Sub-Assy	'390002060021	1

Above data is subject to change without notice, pls refer the SP in global service website.

Exploded View of GMV-N71U/C-T, GMV-N140U/C-T, GMV-N280U/C-T:

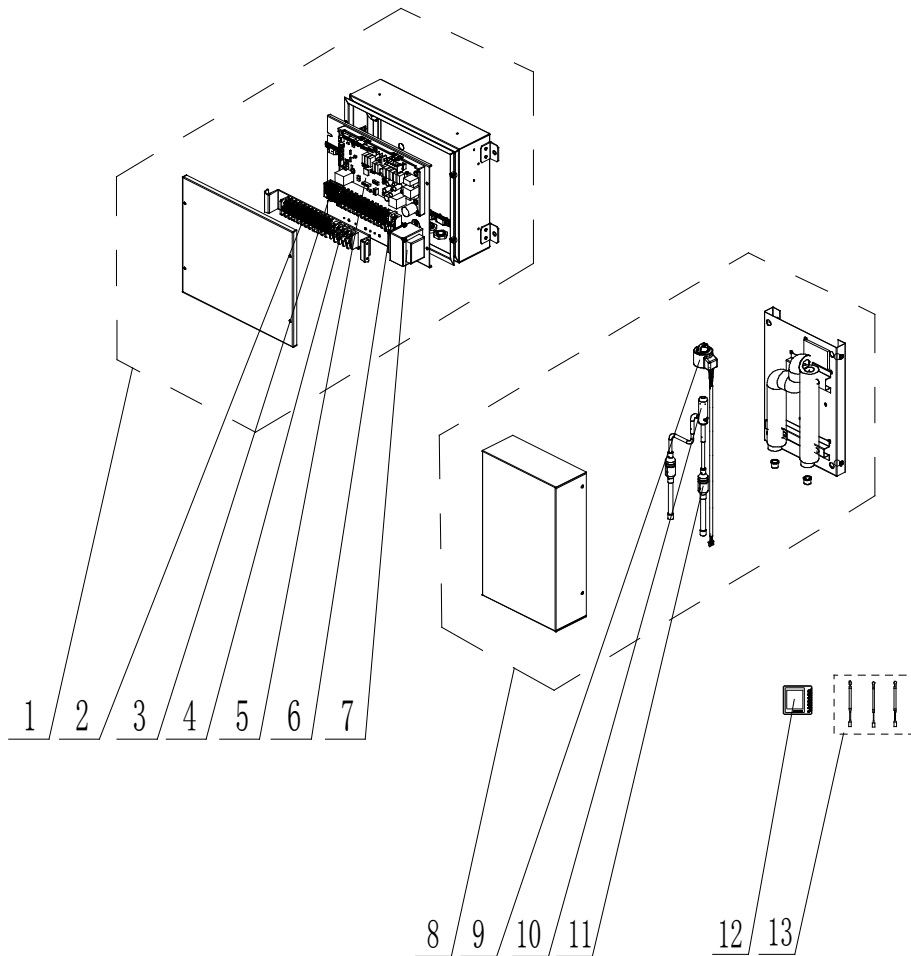

No.	Name of part	For the following unit	
		Unit	Product Code
		GMV-N71U/C-T	CN750N0200
		GMV-N140U/C-T	CN750N0180
		GMV-N280U/C-T	CN750N0170
		Part code	Quantity
1	Electric Box Assy	10002066409	1
2	Terminal Board	'422000000009	2
3	Terminal Board	'42200006000401	1
4	Terminal Board	'42200006000901	1
5	Main Board	'30002060941	1
6	Terminal Board	'42000100000101	1
7	Transformer	'450002060013	1
8	Electronic Expansion Valve Assy	'030174060015	1
9	Electric Expand Valve Fitting	'0741520000201	2
10	Electronic Expansion Valve	'4304413239	1
11	Strainer	'43044100190	1
12	Display Board	'30296000040	1
13	Sensor Sub-Assy	'390002060021	1

Above data is subject to change without notice, pls refer the SP in global service website.

Exploded View of GMV-N560U/C-T

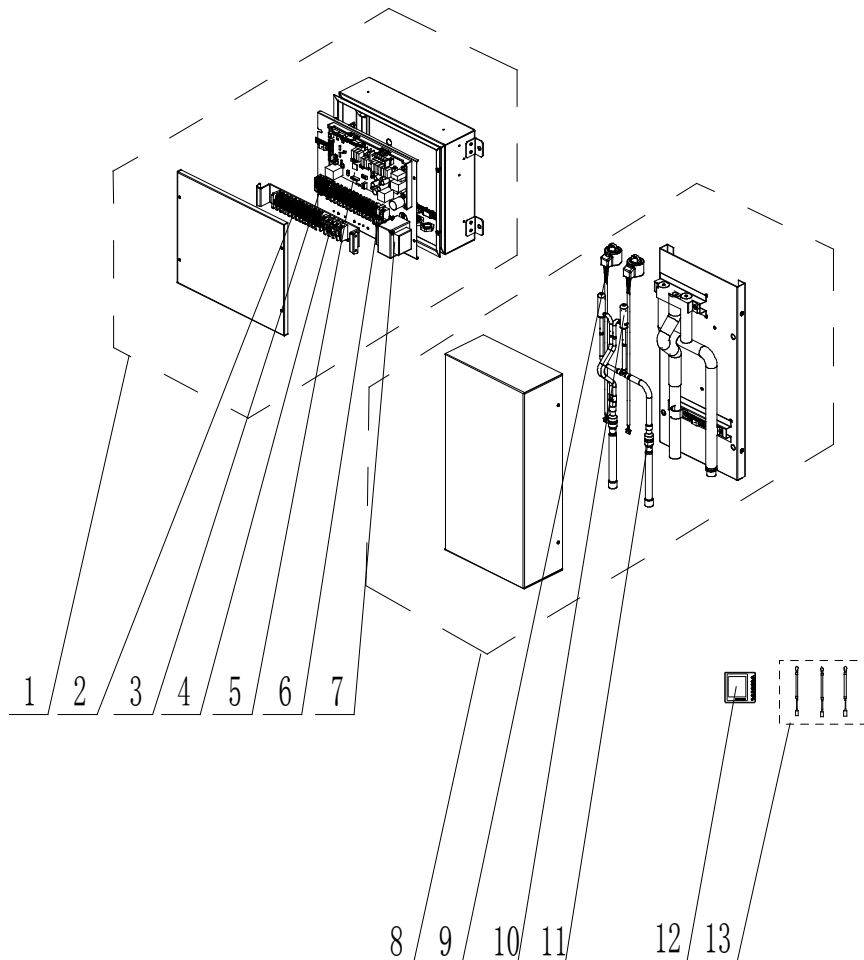

NO.	Model	GMV-N560U/C-T	Qty.
	Product Code	CN750N0160	
	Part Name	Part Code	
1	Electric Box Assy	100002066409	1
2	Terminal Board	422000000009	1
3	Terminal Board	42200006000401	1
4	Terminal Board	42200006000901	1
5	Main Board	300002060941	1
6	Terminal Board	300002060941	1
7	Transformer	450002060013	1
8	Electronic Expansion Valve assy	030174060011	1
9	Electric Expand Valve Fitting	4304413239	2
10	Electronic Expansion Valve	43044100190	2
11	Strainer	0721212101	2
12	Display Board	30296000040	1
13	Sensor Sub-assy	390002060021	1

Above data is subject to change without notice, pls refer the SP in global service website.

5.16 Concealed Floor Standing Type

Exploded View of GMV-ND22ZA/A-T, GMV-ND28ZA/A-T, GMV-ND36ZA/A-T:

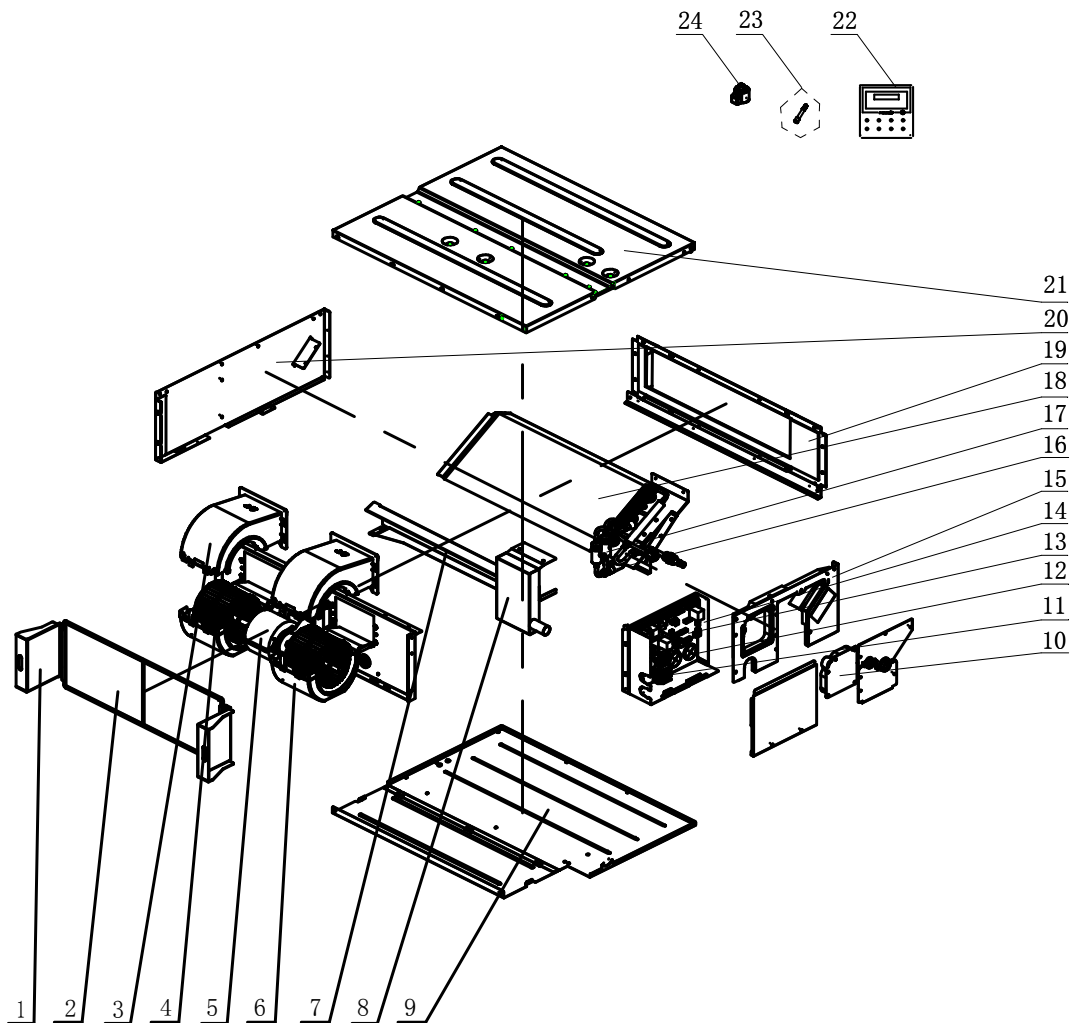

No.	Name of part	For the following unit	
		Unit	Product Code
		GMV-ND22ZA/A-T	CM810N1490
		GMV-ND28ZA/A-T	CM810N1480
		GMV-ND36ZA/A-T	CM810N1460
		Part code	Quantity
1	Supporter	012060002587	2
2	Filter Sub-Assy	111001000102	1
3	Front Volute Casing	26905205	2
4	Centrifugal Fan	10425200	2
5	Brushless DC Motor	15704100001	1
6	Rear Volute Casing	26905206	2
7	Water Tray Assy	000069060002	1
8	Water Tray Assy	000069000112	1
9	Bottom Cover Plate Assy	000133000016	1
10	Sealplate sub-assy (drainage)	01495318	1
11	Terminal Board	4201800002601	1

No.	Name of part	For the following unit	
		Unit	Product Code
		GMV-ND22ZA/A-T	CM810N1490
		GMV-ND28ZA/A-T	CM810N1480
		GMV-ND36ZA/A-T	CM810N1460
		Part code	Quantity
12	Terminal Board	42000100000101	1
13	Main Board	30226000029	1
14	Electric Box Assy	100002004224	1
15	Left Side Plate Assy	01315200087	1
16	Electronic Expansion Valve	07334463	1
17	Strainer	0741410000601	2
18	Evaporate Assy	011001000641	1
19	Air Outlet Frame Assy	000141000028	1
20	Right Side Plate Assy	000081000034	1
21	Top Cover Board Assy	000132000029	1
22	Display Board	30296000040	1
23	Sensor Sub-assy	39004168G	1
24	Electric Expand Valve Fitting	4304413215	1

Above data is subject to change without notice, pls reference the SP in global service website.

Exploded View of GMV-ND45ZA/A-T:

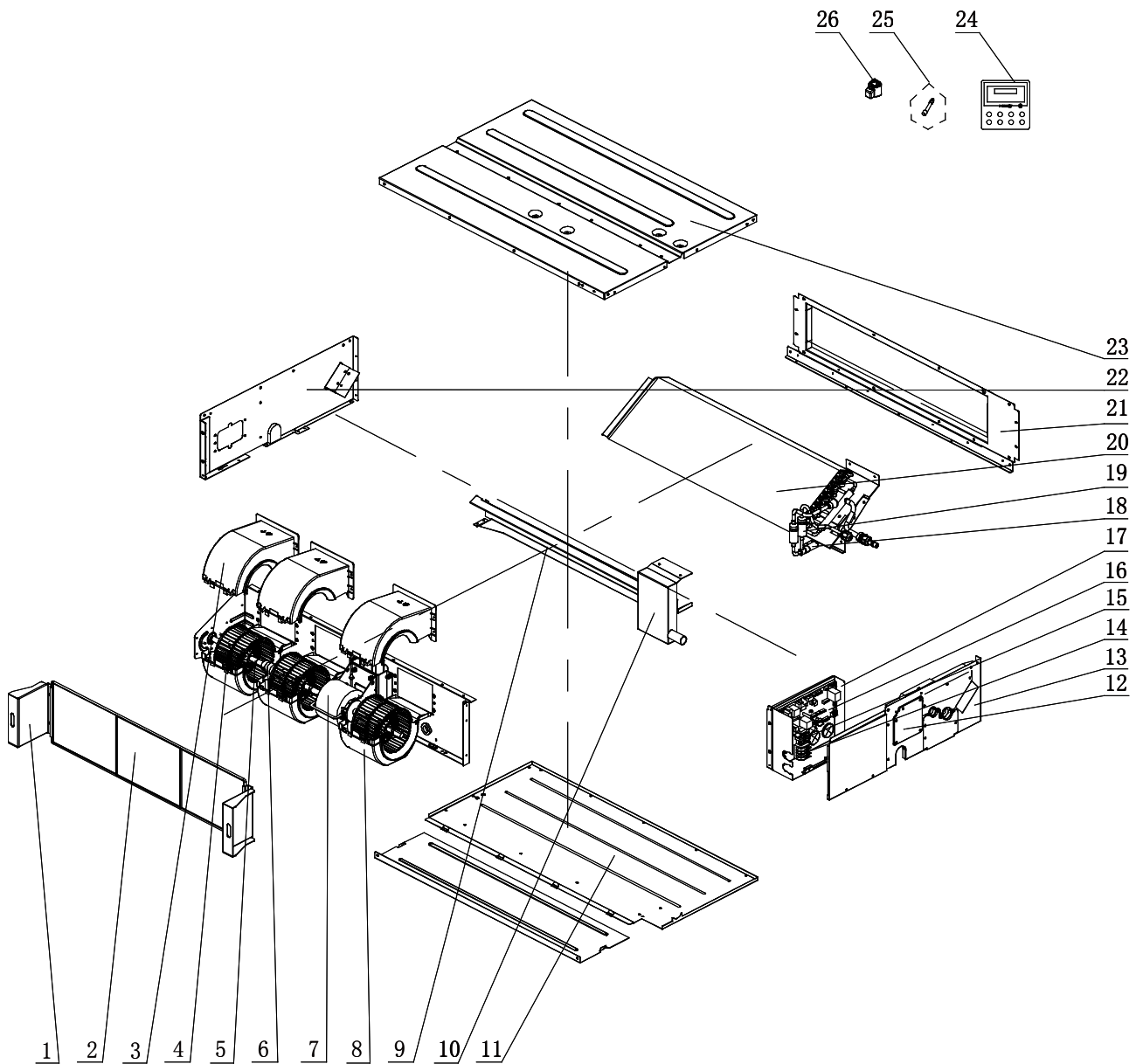

No.	Name of part	For the following unit	
		Unit	Product Code
		GMV-ND45ZA/A-T	CM810N1470
		Part code	Quantity
1	Supporter	012060002587	2
2	Filter Sub-Assy	111001000101	1
3	Front Volute Casing	26905205	3
4	Centrifugal Fan	10425200	3
5	Rotray Axis Sub-Assy	73018020	1
6	Joint Slack	73018731	1
7	Brushless DC Motor	15704100001	1
8	Rear Volute Casing	26905206	3
9	Water Tray Assy	000069060001	1
10	Water Tray Assy	000069000112	1
11	Bottom Cover Plate Assy	000133000015	1
12	Sealplate sub-assy (drainage)	01495318	1
13	Left Side Plate Assy	01315200087	1

No.	Name of part	For the following unit	
		Unit	Product Code
		GMV-ND45ZA/A-T	CM810N1470
		Part code	Quantity
14	Terminal Board	4201800002601	1
15	Terminal Board	42000100000101	1
16	Main Board	30226000029	1
17	Electric Box Assy	100002004224	1
18	Electronic Expansion Valve	07334466	1
19	Strainer	0741410000601	2
20	Evaporate Assy	011001060025	1
21	Air Outlet Frame Assy	000141000026	1
22	Right Side Plate Assy	000081000032	1
23	Top Cover Board Assy	000132000026	1
24	Display Board	30296000040	1
25	Sensor Sub-assy	39004168G	1
26	Electric Expand Valve Fitting	4304413215	1

Above data is subject to change without notice, pls reference the SP in global service website.

Exploded View of GMV-ND56ZA/A-T:

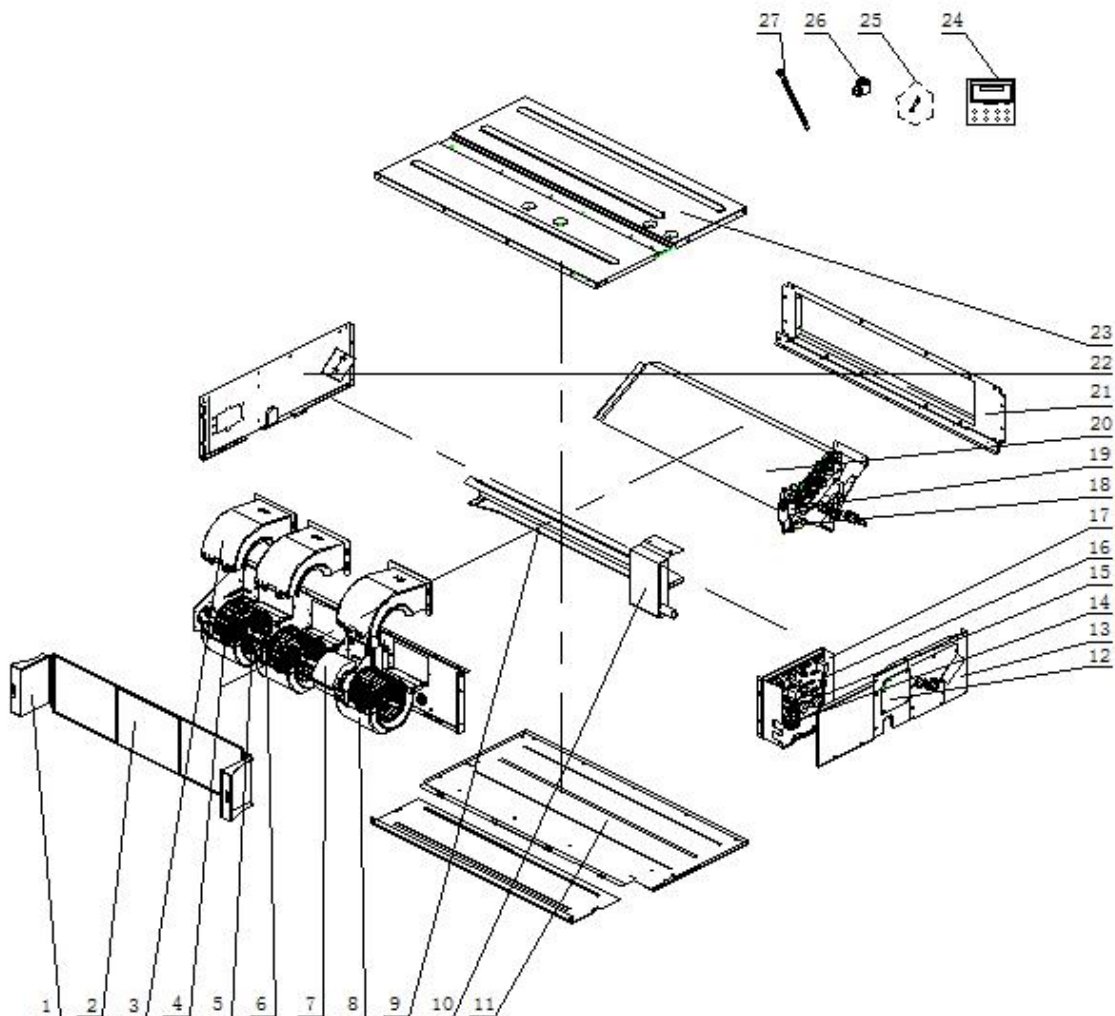

No.	Name of part	For the following unit	
		Unit	Product Code
		GMV-ND56ZA/A-T	CM810N1451
		GMV-ND63ZA/A-T	CM810N1440
		GMV-ND71ZA/A-T	CM810N1430
		Part code	Quantity
1	Supporter	012060002587	2
2	Filter Sub-Assy	111001000101	1
3	Front Volute Casing	26905205	3
4	Centrifugal Fan	10425200	3
5	Rotray Axis Sub-Assy	73018020	1
6	Joint Slack	73018731	1
7	Brushless DC Motor	15704100001	1
8	Rear Volute Casing	26905206	3
9	Water Tray Assy	000069060001	1
10	Water Tray Assy	000069000112	1
11	Bottom Cover Plate Assy	000133000015	1
12	Sealplate sub-assy (drainage)	01495318	1
13	Left Side Plate Assy	01315200087	1
14	Terminal Board	4201800002601	1
15	Terminal Board	42000100000101	1
16	Main Board	30226000029	1
17	Electric Box Assy	100002004224	1
18	Electronic Expansion Valve	07334466	1
19	Strainer	0741410000601	2
20	Evaporate Assy	011001060025	1
21	Air Outlet Frame Assy	000141000026	1
22	Right Side Plate Assy	000081000032	1
23	Top Cover Board Assy	000132000026	1
24	Display Board	30296000040	1
25	Sensor Sub-assy	39004168G	1
26	Electric Expand Valve Fitting	4304413215	1
27	Corrugated Pipe	05015408	1

Above data is subject to change without notice, pls reference the SP in global service website.

5.17 360°Air Discharge Cassette Type

Exploded View of

GMV-ND22T/C-T,GMV-ND28T/C-T

:

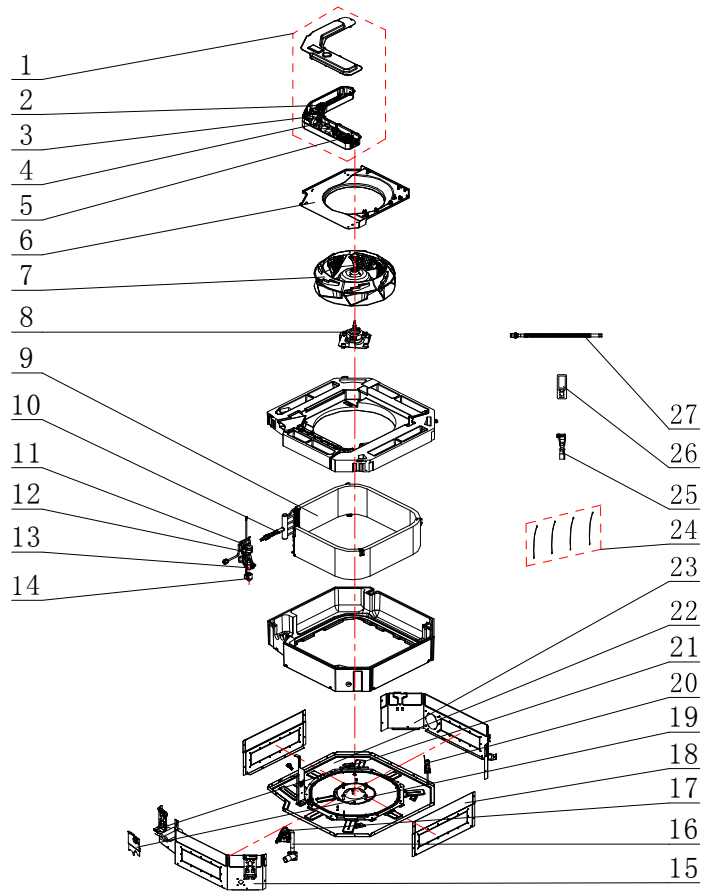

No.	Name of part	For the following unit	
		Unit	Product Code
		GMV-ND22T/C-T	CM500N1680
		GMV-ND28T/C-T	CM500N1660
		Part code	Quantity
1	Electric Box Assy	100002066372	1
2	Diversion Circle	26909400067	1
3	Centrifugal Fan	10429400004	1
4	Brushless DC Motor	1570410000702	1
5	Evaporator Assy	11001000430	1
6	Strainer	7415210	1
7	Electronic Expansion Valve	7334463	1
8	Strainer	7213050	1
9	Electric Expand Valve Fitting	4304413252	1
10	Liquid Level Switch	4502021601	1
11	Body Installing Plate	1332701	4
12	Seat Board Sub-Assy	2229400011	1
13	Remote Controller	30510570	1
14	Sensor Sub-Assy	390002000032	1
15	Corrugated Pipe	040001000002	1
16	Drain Hose	05232044	1
17	Drainage Pipe Sub-Assy	26909400055	1
18	Water Pump	43138000058	1
19	Corrugated Pipe	40001000002	1
20	Main Board	300002060274	1
21	Filter Board	30221000021	1
22	Terminal Board	42011106	1
23	Terminal Board	42200006000401	1

GMV-ND36T/C-T:

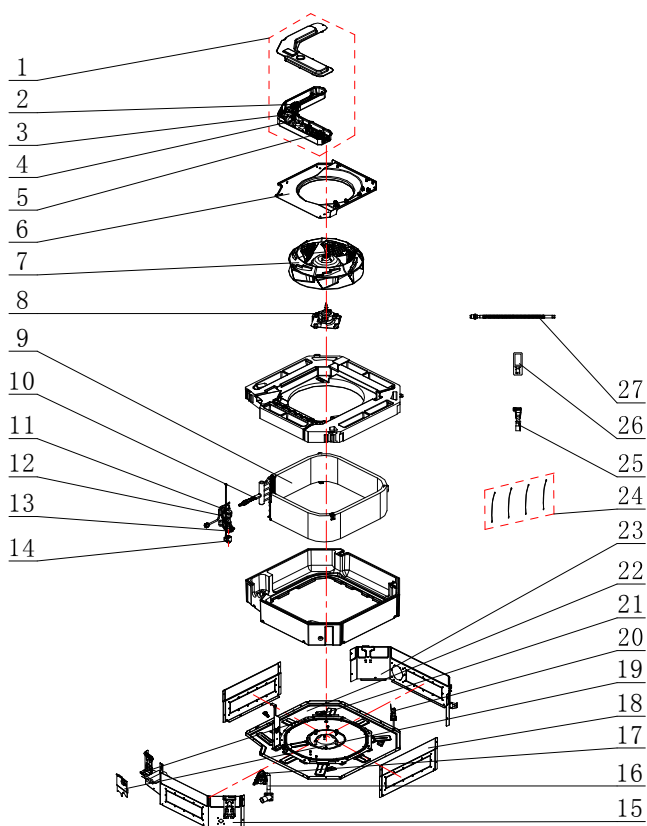

No.	Name of part	For the following unit	
		Unit	Product Code
		GMV-ND36T/C-T	CM500N1670
		Part code	Quantity
1	Electric Box Assy	10002066372	1
2	Diversion Circle	26909400067	1
3	Centrifugal Fan	10429400004	1
4	Brushless DC Motor	1570410000702	1
5	Evaporator Assy	11001000404	1
6	Strainer	07415210	1
7	Electronic Expansion Valve	07334463	1
8	Strainer	07213050	1
9	Electric Expand Valve Fitting	4304413252	1
10	Liquid Level Switch	4502021601	1
11	Body Installing Plate	01332701	4
12	Seat Board Sub-Assy	02229400011	1
13	Remote Controller	30510570	1
14	Sensor Sub-Assy	390002000032	1
15	Corrugated Pipe	035030000008	1
16	Drain Hose	05232044	1
17	Drainage Pipe Sub-Assy	26909400055	1
18	Water Pump	43138000058	1
19	Corrugated Pipe	035030000008	1
20	Main Board	300002060274	1
21	Filter Board	30221000021	1
22	Terminal Board	42011106	1
23	Terminal Board	42200006000401	1

GMV-ND45T/C-T:

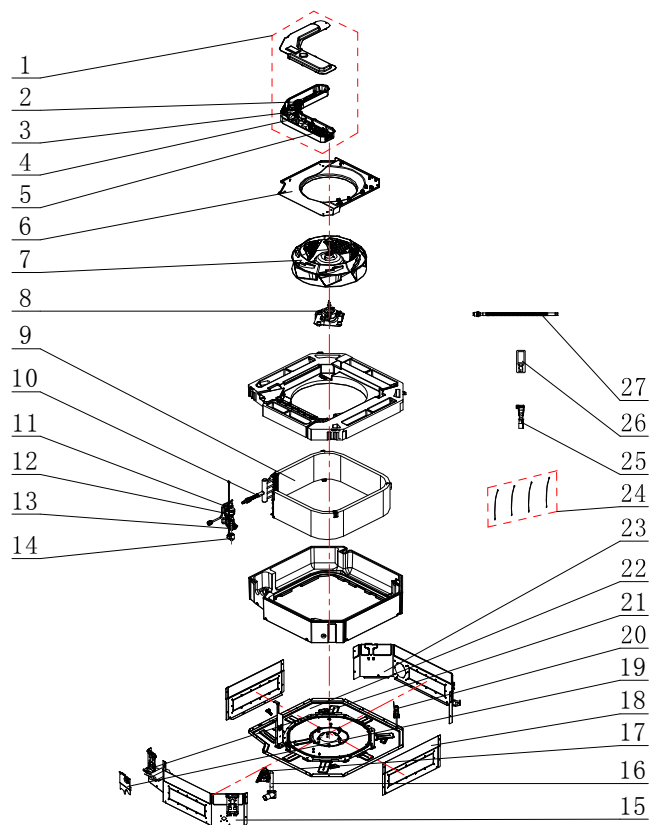

No.	Name of part	For the following unit	
		Unit	Product Code
		GMV-ND45T/C-T	CM500N1650
		Part code	Quantity
1	Electric Box Assy	100002066372	1
2	Diversion Circle	26909400067	1
3	Centrifugal Fan	10429400004	1
4	Brushless DC Motor	1570410000702	1
5	Evaporator Assy	11001000404	1
6	Strainer	07415210	1
7	Electronic Expansion Valve	07334463	1
8	Strainer	07213050	1
9	Electric Expand Valve Fitting	4304413252	1
10	Liquid Level Switch	4502021601	1
11	Body Installing Plate	01332701	4
12	Seat Board Sub-Assy	02229400011	1
13	Remote Controller	30510570	1
14	Sensor Sub-Assy	390002000032	1
15	Corrugated Pipe	035030000008	1
16	Drain Hose	05232044	1
17	Drainage Pipe Sub-Assy	26909400055	1
18	Water Pump	43138000058	1
19	Corrugated Pipe	035030000008	1
20	Main Board	300002060274	1
21	Filter Board	30221000021	1
22	Terminal Board	42011106	1
23	Terminal Board	42200006000401	1

GMV-ND50T/C-T:

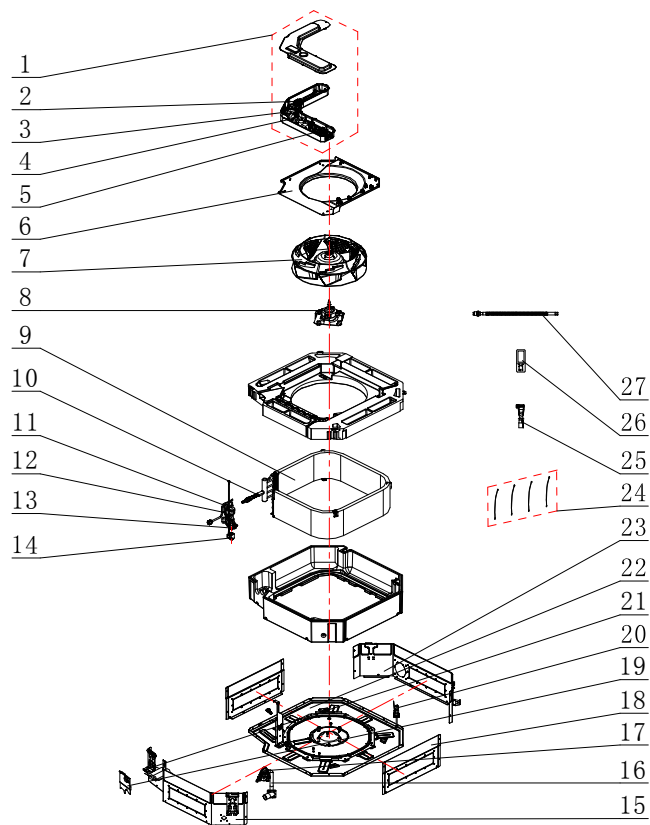

No.	Name of part	For the following unit	
		Unit	Product Code
		GMV-ND50T/C-T	CM500N1640
		Part code	Quantity
1	Electric Box Assy	10002066372	1
2	Diversion Circle	26909400067	1
3	Centrifugal Fan	10429400004	1
4	Brushless DC Motor	1570410000702	1
5	Evaporator Assy	011001000239	1
6	Strainer	07415210	1
7	Electronic Expansion Valve	07334463	1
8	Strainer	07213050	1
9	Electric Expand Valve Fitting	4304413252	1
10	Liquid Level Switch	4502021601	1
11	Body Installing Plate	01332701	4
12	Seat Board Sub-Assy	02229400011	1
13	Remote Controller	30510589	1
14	Sensor Sub-Assy	390002000032	1
15	Corrugated Pipe	035030000008	1
16	Drain Hose	05232044	1
17	Drainage Pipe Sub-Assy	26909400055	1
18	Water Pump	43138000058	1
19	Corrugated Pipe	035030000008	1
20	Main Board	300002060274	1
21	Filter Board	30221000021	1
22	Terminal Board	42011106	1
23	Terminal Board	42200006000401	1

GMV-ND56T/C-T,GMV-ND63T/C-T,GMV-ND71T/C-T

:

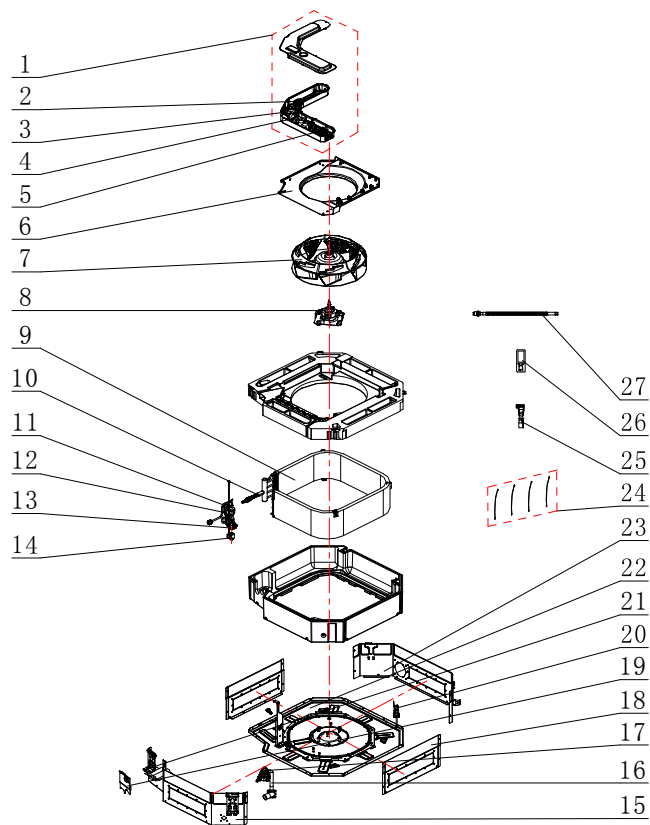

No.	Name of part	For the following unit	
		Unit	Product Code
		GMV-ND56T/C-T	CM500N1630
		GMV-ND63T/C-T	CM500N1440
		GMV-ND71T/C-T	CM500N1370
		Part code	Quantity
1	Electric Box Assy	100002066372	1
2	Diversion Circle	26909400067	1
3	Centrifugal Fan	10429400004	1
4	Brushless DC Motor	1570410000702	1
5	Evaporator Assy	011001000410	1
6	Strainer	07415210	1
7	Electronic Expansion Valve	07334463	1
8	Strainer	07213050	1
9	Electric Expand Valve Fitting	4304413252	1
10	Liquid Level Switch	4502021601	1
11	Body Installing Plate	01332701	4
12	Seat Board Sub-Assy	02229400011	1
13	Remote Controller	30510589	1
14	Sensor Sub-Assy	390002000032	1
15	Corrugated Pipe	035030000007	1
16	Drain Hose	05232044	1
17	Drainage Pipe Sub-Assy	26909400055	1
18	Water Pump	43138000058	1
19	Corrugated Pipe	035030000007	1
20	Main Board	300002060274	1
21	Filter Board	30221000021	1
22	Terminal Board	42011106	1
23	Terminal Board	42200006000401	1

GMV-ND80T/C-T,GMV-ND90T/C-,GMV-ND100T/C-T:

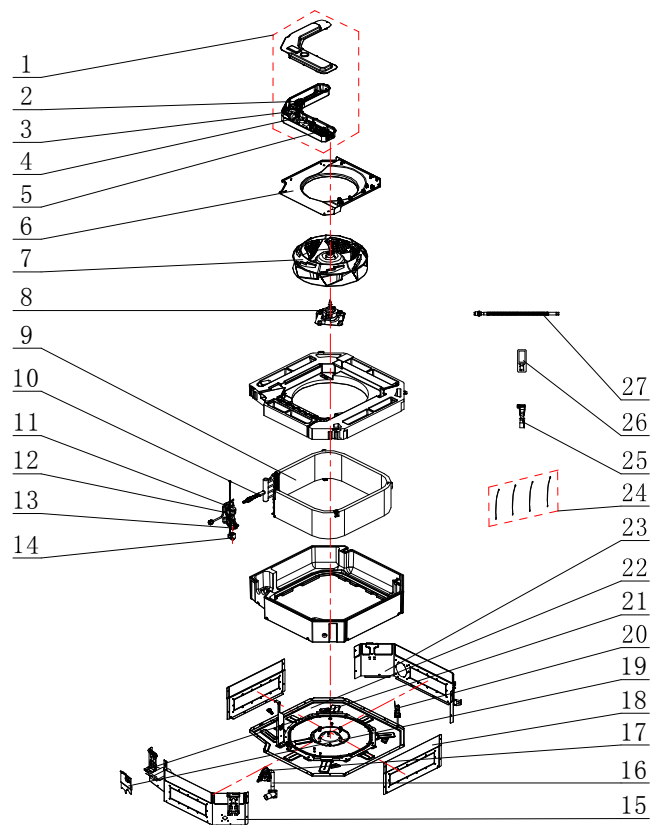

No.	Name of part	For the following unit	
		Unit	Product Code
		GMV-ND80T/C-T	CM500N1430
		GMV-ND90T/C-T	CM500N1420
		GMV-ND100T/C-T	CM500N1380
		Part code	Quantity
1	Electric Box Assy	100002066372	1
2	Diversion Circle	26909400067	1
3	Centrifugal Fan	10429400004	1
4	Brushless DC Motor	1570410000702	1
5	Evaporator Assy	011001000236	1
6	Strainer	07415210	1
7	Electronic Expansion Valve	07334466	1
8	Strainer	07213050	1
9	Electric Expand Valve Fitting	4304413252	1
10	Liquid Level Switch	4502021601	1
11	Body Installing Plate	01332701	4
12	Seat Board Sub-Assy	02229400011	1
13	Remote Controller	30510589	1
14	Sensor Sub-Assy	390002000032	1
15	Corrugated Pipe	035030000007	1
16	Drain Hose	05232044	1
17	Drainage Pipe Sub-Assy	26909400055	1
18	Water Pump	43138000058	1
19	Corrugated Pipe	035030000007	1
20	Main Board	300002060274	1
21	Filter Board	30221000021	1
22	Terminal Board	42011106	1
23	Terminal Board	42200006000401	1

GMV-ND112T/C-T,GMV-ND125T/C-T,GMV-ND140T/C-T:

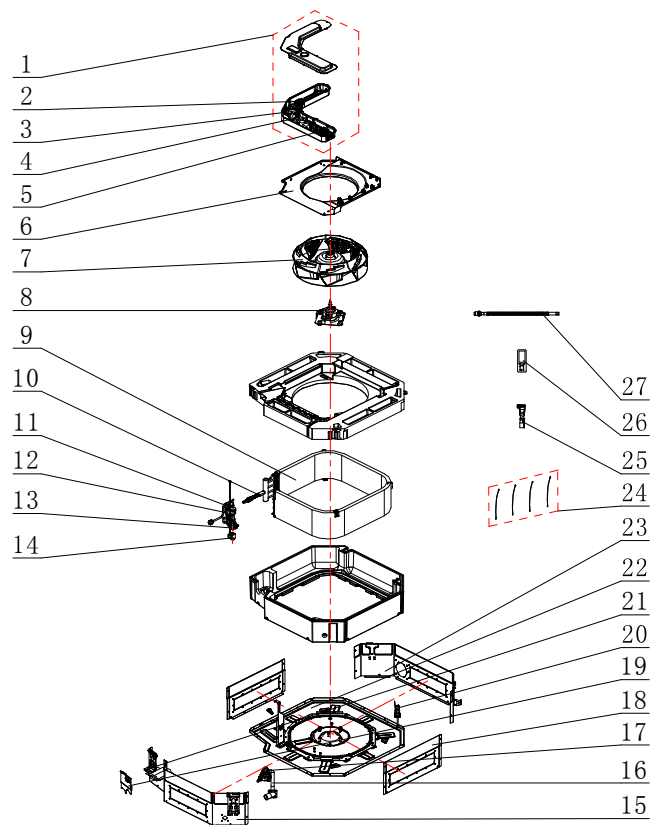

No.	Name of part	For the following unit	
		Unit	Product Code
		GMV-ND112T/C-T	CM500N1400
		GMV-ND125T/C-T	CM500N1410
		GMV-ND140T/C-T	CM500N1360
		Part code	Quantity
1	Electric Box Assy	100002066372	1
2	Diversion Circle	10479400002	1
3	Centrifugal Fan	10429400003	1
4	Brushless DC Motor	15709400009	1
5	Evaporator Assy	011001000405	1
6	Strainer	07415210	1
7	Electronic Expansion Valve	07334468	1
8	Strainer	07213050	1
9	Electric Expand Valve Fitting	4304413252	1
10	Liquid Level Switch	4502021601	1
11	Body Installing Plate	01332701	4
12	Seat Board Sub-Assy	02229400011	1
13	Remote Controller	30510589	1
14	Sensor Sub-Assy	390002000032	1
15	Corrugated Pipe	035030000007	1
16	Drain Hose	05232044	1
17	Drainage Pipe Sub-Assy	26909400055	1
18	Water Pump	43138000058	1
19	Corrugated Pipe	035030000007	1
20	Main Board	300002060274	1
21	Filter Board	30221000021	1
22	Terminal Board	42011106	1
23	Terminal Board	42200006000401	1

Above data is subject to change without notice, pls reference the SP in global service website.

5.18 Heat Storage Module

Exploded View of XRZ180L/A-T

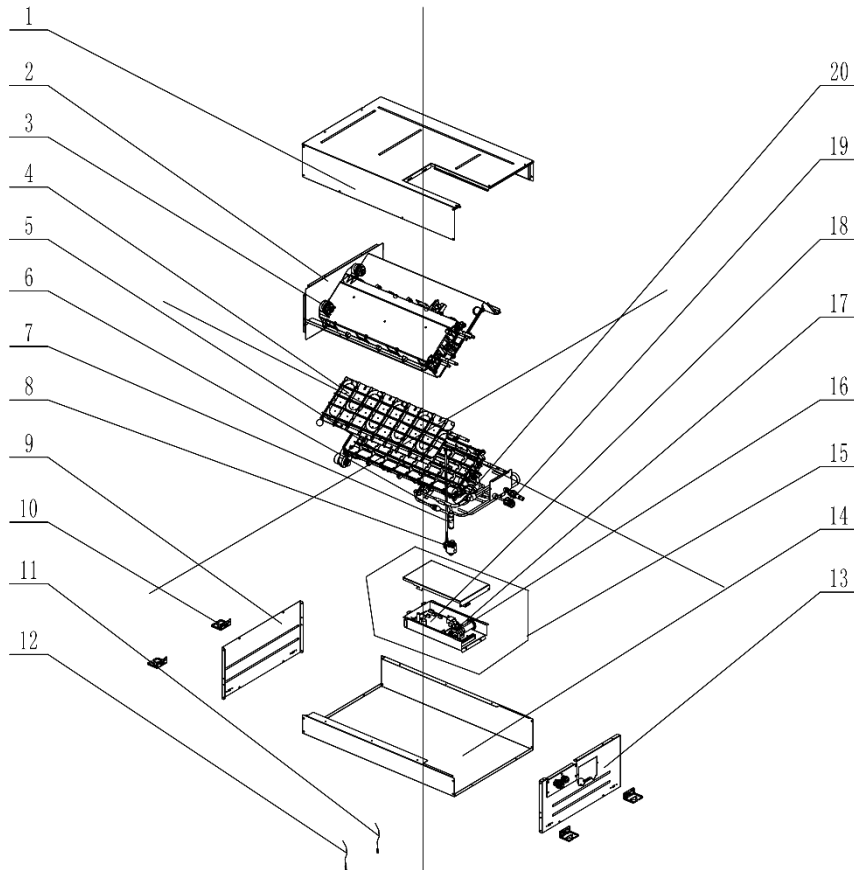

No.	Name of part	For the following unit	
		Unit	Product Code
		XRZ180L/A-T	CM810N2250
		Part code	Quantity
1	Top Cover	012148060003	1
2	Base Frame	012252060002	1
3	Compressor Gasket	76713066	1
4	Heat Accumulator Sub-assy	32005002	1
5	Heat Accumulator Sub-assy	32005003	1
6	Strainer	0721304401	1
7	Electronic Expansion Valve	07334466	1
8	Electric Expand Valve Fitting	4304413252	1
9	Right Side Plate	012056060003	1
10	Hook	0220410001201	1
11	Temperature Sensor	390001060013	1
12	Temperature Sensor	390001060011	1
13	Left Side Plate	012055060004	1
14	Bottom Cover Plate	012147060005	1
15	Electric Box Assy	100002071026	1
16	Terminal Board	42011106	1
17	Terminal Board	420001000019	1
18	Main Board	300002000795	1
19	Sealing Cap(Pressure Warning)	26112192	1
20	Strainer A	0721002201	1

Above data is subject to change without notice, pls reference the SP in global service website.



GREE ELECTRIC APPLIANCES, INC. OF ZHUHAI 519070

Add: West Jinji Rd, Qianshan Zhuhai, Guangdong, China

Tel: (+86-756)8522218

Fax: (+86-756)8669426

E-mail: global@cn.gree.com www.gree.com

JF00302966