



Owner's Manual

Original Instructions

Commercial Air Conditioners

Multi Variable Air Conditioners

Cassette Type Indoor Unit

Models:

GMV-ND28T/A-T	GMV-ND36T/A-T
GMV-ND45T/A-T	GMV-ND50T/A-T
GMV-ND56T/A-T	GMV-ND63T/A-T
GMV-ND71T/A-T	GMV-ND80T/A-T
GMV-ND90T/A-T	GMV-ND100T/A-T
GMV-ND112T/A-T	GMV-ND125T/A-T
GMV-ND140T/A-T	GMV-ND160T/A-T

Thank you for choosing commercial air conditioners. Please read this Owner's Manual carefully before operation and retain it for future reference.

If you have lost the Owner's Manual, please contact the local agent or visit www.gree.com or send an email to global@cn.gree.com for the electronic version.

GREE ELECTRIC APPLIANCES, INC. OF ZHUHAI



To Users

Thank you for selecting Gree product. Please read this instruction manual carefully before installing and using the product, so as to master and correctly use the product. In order to guide you to correctly install and use our product and achieve expected operating effect, we hereby instruct as below:

- (1) This appliance can be used by children aged from 8 years and above and persons with reduced physical, sensory or mental capabilities or lack of experience and knowledge if they have been given supervision or instruction concerning use of the appliance in a safe way and understand the hazards involved. Children shall not play with the appliance. Cleaning and user maintenance shall not be made by children without supervision.
- (2) In order to ensure reliability of product, the product may consume some power under stand-by status for maintaining normal communication of system and preheating refrigerant and lubricant. If the product is not to be used for long, cut off the power supply; please energize and preheat the unit in advance before reusing it.
- (3) Please properly select the model according to actual using environment; otherwise it may impact the using convenience.
- (4) This product can't be installed at corrosive, inflammable or explosive environment or the place with special requirements, such as kitchen. Otherwise, it will affect the normal operation or shorten the service life of the unit, or even cause fire hazard or serious injury. As for above special places, please adopt special air conditioner with anti-corrosive or anti-explosion function.
- (5) If the product needs to be installed, moved or maintained, please contact our designated dealer or local service center for professional support. Users should not disassemble or maintain the unit by themselves, otherwise it may cause relative damage, and our company will bear no responsibilities.
- (6) All the illustrations and information in the instruction manual are only for reference. In order to make the product better, we will continuously conduct improvement and innovation. If there is adjustment in the product, please subject to actual product.

Exception Clauses

Manufacturer will bear no responsibilities when personal injury or property loss is caused by the following reasons:

- (1) Damage the product due to improper use or misuse of the product.
- (2) Alter, change, maintain or use the product with other equipment without abiding by the instruction manual of manufacturer.
- (3) After verification, the defect of product is directly caused by corrosive gas.
- (4) After verification, defects are due to improper operation during transportation of product.
- (5) Operate, repair, maintain the unit without abiding by instruction manual or related regulations.
- (6) After verification, the problem or dispute is caused by the quality specification or performance of parts and components that produced by other manufacturers.
- (7) The damage is caused by natural calamities, bad using environment or force majeure.

Contents

1 Safety Notices (Please be sure to abide)	1
2 Product Introduction	4
2.1 Names of Key Components.....	4
2.2 Rated Working Condition.....	4
3 Preparations for Installation	4
3.1 Standard Fittings.....	4
3.2 Installation Position Selection.....	5
3.3 Requirements of Communication Wire Selection	6
3.4 Wiring Requirement.....	7
4 Installation Instructions	8
4.1 Indoor Unit Installation	8
4.2 Refrigerant Pipe Connection	11
4.3 Drainage Pipe Installation and Drainage System Testing.....	12
4.4 Panel Installation	15
4.5 Wired Controller Installation	16
5 Wiring Work	17
5.1 Connection of Wire and Patch Board Terminal.....	17
5.2 Power Cord Connection	18
5.3 Connection of Communication Wire between Indoor Unit and Outdoor Unit (or indoor unit)	18
5.4 Connection of Communication Wire for Wired Controller.....	19
5.5 Instructions on Connecting Wired Controller and Indoor Units Network	19
6 Routine Maintenance	21
6.1 Cleaning of Filter	21
6.2 Maintenance Before The Seasonal Use	21
6.3 Maintenance After The Seasonal Use	21
7 Table of Error Codes for Indoor Unit	22
8 Troubleshooting	22

1 Safety Notices (Please be sure to abide)



WARNING: If not abide strictly, it may cause severe damage to the unit or the people.



NOTE: If not abide strictly, it may cause slight or medium damage to the unit or the people.



This sign indicates that the operation must be prohibited. Improper operation may cause severe damage or death to people.



This sign indicates that the items must be observed. Improper operation may cause damage to people or property.



WARNING!

This product can't be installed at corrosive, inflammable or explosive environment or the place with special requirements, such as kitchen. Otherwise, it will affect the normal operation or shorten the service life of the unit, or even cause fire hazard or serious injury. As for above special places, please adopt special air conditioner with anti-corrosive or anti-explosion function.











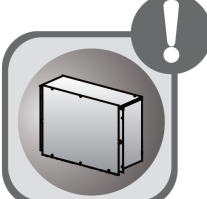
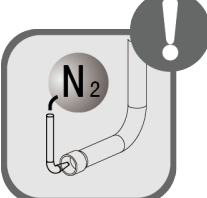

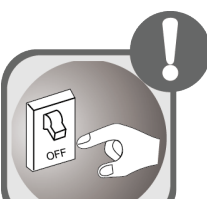

This Multi VRF System shall only be connected to an appliance suitable for the same refrigerant.

All units in Manual Cover is a partial unit, complying with partial unit of IEC 60335-2-40:2018, and must only be connected to other units that have been confirmed as complying to corresponding partial unit requirements of this international standard.

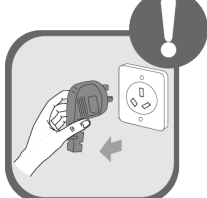

The electrical interface shall comply with electrical security requirement, voltage shall be 220-240V~50Hz or 208-230V~60Hz, current shall be referred to the table of "Dimension of power cord and capacity of air switch" in Section 3.4, and safety class of construction is I.

	<p>Please install the unit according to instructions in this manual. Read this manual carefully before starting up or checking the machine.</p>		<p>Installation should be performed by dealer or qualified technicians. Do not install the product by yourself. Improper installation may result in water leakage, electric shock or fire hazard.</p>
	<p>Make sure the local power supply is in accordance with units before installation, and check the power supply carefully.</p>		<p>This air conditioner must be properly grounded through the receptacle to avoid electric shock. The grounding wire shouldn't be connected with gas pipe, water pipe, lightning arrester or telephone line.</p>
	<p>Please use specialized accessories or parts to carry out installation, or water leakage, electric shock, fire hazard may resulted.</p>		<p>R410A refrigerant can produce poisonous gas once it meets fire, so please ventilate the room immediately if refrigerant leaks out during installation.</p>

Multi Variable Air Conditioners Cassette Type Indoor Unit

 <p>Specialized</p>	<p>Diameter of power cord must be large enough. Damaged power cord and connecting wire must be replaced by specialized electric cable.</p>		<p>After the power cord is connected, please install the cover of electric box to avoid danger.</p>
 <p>N₂</p>	<p>Nitrogen must be charged according to technical requirements.</p>		<p>Short circuit is forbidden. Do not cancel the pressure switch in case the unit may be damaged.</p>
	<p>For units with wired controller, do not connect power supply until the wired controller is well installed. Otherwise, the wired controller cannot be used.</p>		<p>When the installation is finished, please check and make sure the drain pipe, pipeline and electric wire are all well connected in order to avoid water leakage, refrigerant leakage, electric shock or fire hazard.</p>
	<p>Do not extend fingers or objects into air outlet or air return grille.</p>		<p>If you use gas heater or petroleum heater in the same room, please open the door or window to maintain good air circulation in case the room may lack of oxygen.</p>
	<p>Never start or stop the air conditioner by inserting or removing the power cord.</p>	 <p>< 5Min</p>	<p>Do not turn off the air conditioner until it runs for at least 5 minutes. Otherwise, oil-return of the compressor will be affected.</p>
	<p>Children are not allowed to operate the air conditioner.</p>		<p>Do not operate the air conditioner with wet hands.</p>
	<p>Please turn the unit off and unplug your air conditioner before cleaning. Otherwise, it may cause electric shock or personal injury.</p>		<p>Do not spray water on the air conditioner or it will cause malfunction or electric shock.</p>
	<p>Do not expose the air conditioner directly to water or place it in a damp or corrosive environment.</p>	 <p>24H</p>	<p>Connect power supply 8 hours before operation. Do not disconnect power if you want to stop the unit in a short period of time, e.g. in one night (This is for protecting the compressor).</p>

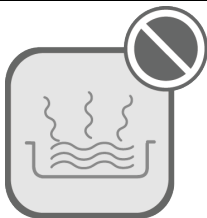
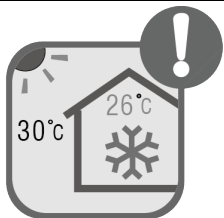
Multi Variable Air Conditioners Cassette Type Indoor Unit

	<p>Volatile liquid like thinner or gasoline will damage the appearance of air conditioner. Please use soft dry cloth or wet cloth with mild detergent to clean the outer case of air conditioner.</p>		<p>During Cooling mode, indoor temperature should not be set too low. Keep the difference between indoor temp and outdoor temp within 5°C.</p>
	<p>If abnormal condition occurs (e.g. unpleasant smell), please turn off the unit at once and disconnect power supply. Then contact GREE service center. If the air conditioner continues to operate despite of abnormal condition, the unit may be damaged and it may cause electric shock or fire hazard).</p>		<p>Do not repair the air conditioner by yourself. Improper repair will cause electric shock or fire hazard. Please contact GREE service center and have it repaired by professional technicians.</p>

Any personal injury or property loss caused by improper installation, improper debug, unnecessary repair or not following the instructions of this manual should not be the responsibility of Gree Electric Appliances, Inc. of Zhuhai.

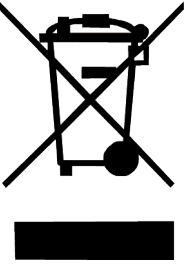
	<p>Correct Disposal of this product</p> <p>This marking indicates that this product should not be disposed with other household wastes throughout the EU. To prevent possible harm to the environment or human health from uncontrolled waste disposal, recycle it responsibly to promote the sustainable reuse of material resources. To return your used device, please use the return and collection systems or contact the retailer where the product was purchased. They can take this product for environmental safe recycling.</p>
--	---

2 Product Introduction

2.1 Names of Key Components

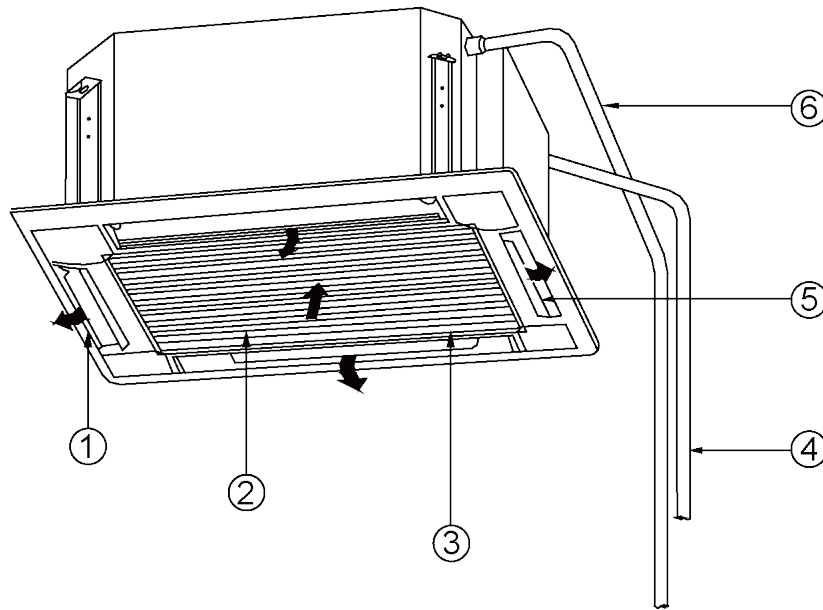

Fig.2.1

No.	①	②	③	④	⑤	⑥
Name	Air Outlet	Filter	Air Inlet Grille	Fittings	Louver	Drainage Pipe

2.2 Rated Working Condition



	Indoor Side Condition		Outdoor Side Condition	
	Dry Bulb Temp (°C)	Wet Bulb Temp (°C)	Dry Bulb Temp (°C)	Wet Bulb Temp (°C)
Rated Cooling	27	19	35	24
Rated Heating	20	15	7	6

3 Preparations for Installation





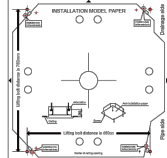

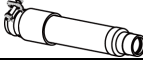

! NOTE! This picture is for reference only, please refers to the actual product, the unit of dimension is mm.

3.1 Standard Fittings

Use the following provided accessories according to the requirement.

No.	Name	Appearance	Q'ty	Usage
1	wireless controller		1 set	To control the indoor unit.
2	paper pattern for installation		1	Locate the drill hole on ceiling.
3	Tapping screw with washer		4	Fix paper pattern.
4	Washer fixing plate		4	Prevent the washer from falling off.

Multi Variable Air Conditioners Cassette Type Indoor Unit

No.	Name	Appearance	Q'ty	Usage
5	Drain Hose Assembly		1	To connect with the hard PVC drain pipe.
6	Special Nut		2	GMV-ND28~50T/A-T.
			1	GMV-ND56~160T/A-T.
7	Corrugated pipe		1	GMV-ND56~160T/A-T.
8	M10 Washer		10	To be used together with the hanger bolt for installing the unit.
9	Insulation		1	To insulate the gas pipe.
10	Insulation		1	To insulate the liquid pipe.
11	Sponge		4	To insulate the drain pipe.
12	Fastener		4	To fasten the sponge.

3.2 Installation Position Selection

- (1) The appliance shall not be installed in the laundry.
- (2) The location should be able to withstand the weight of unit.
- (3) The water can be drained conveniently from drainage pipe.
- (4) There should be no obstruction near air inlet and air outlet.
- (5) Follow the installation distance required in the fig below to ensure sufficient space for maintenance.
- (6) The installation location should be far from heat sources, flammable or explosive gas, or smog spread in the air.
- (7) The indoor unit, outdoor unit, power cord and connection electricity wire should be at least 1m from television and radio in order to prevent interference and noise (Even though 1m distance is ensure, there may be noise if the electric wave is too strong).

Unit:mm

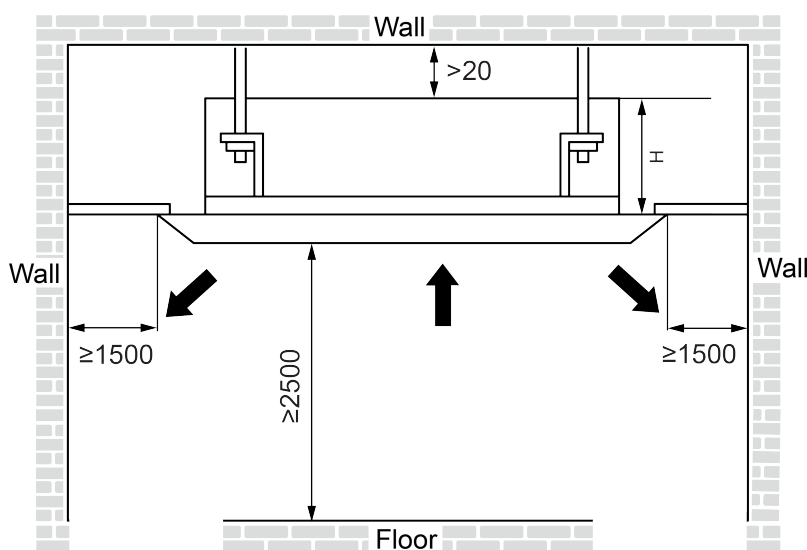

Fig.3.2

Model	H
GMV-ND28~50T/A-T	220
GMV-ND56~80T/A-T	270
GMV-ND90~140T/A-T	350
GMV-ND160T/A-T	310

! NOTES!

- ① The unit shall be installed in accordance with national standards or local regulations.
- ② Only qualified personnel can carry out installation work, please contact with local dealer before installation.
- ③ Make sure all the installation work completed before energizing.
- ④ The appliances are not accessible to general public.

3.3 Requirements of Communication Wire Selection

! NOTE! If air conditioner used under strong electronic-magnetic interference circumstance, STP (shielded twisted pair) communication cable must be adopted.

3.3.1 Selection of Communication Wire Between Indoor Unit and Wired Controller

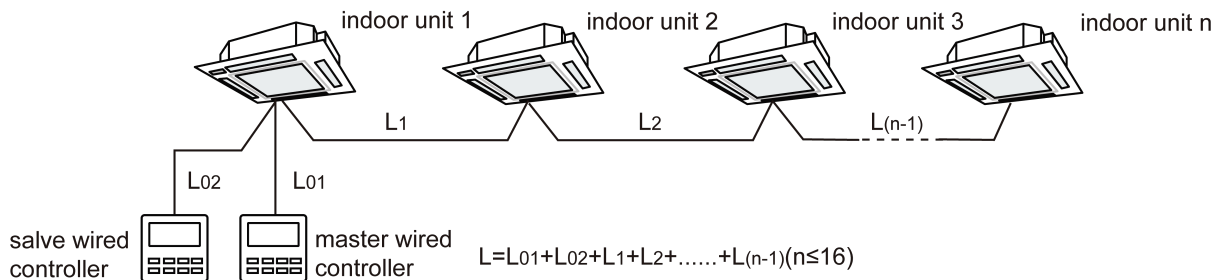

Fig.3.3.1

Wire type	Total length of communication wire between indoor unit and wired controller (m)	Wire diameter (mm ²)	Wire standard	Remark
Light/normal PVC hose	L≤250	2×0.75 ~2×1.25	IEC 60227-5	1. Total length of communication line can't exceed 250m. 2. The cord shall be Circular cord (the cores shall be twisted together). 3. If unit is installed in places with intense magnetic field or strong interference, it is necessary to use shielded wire.

Multi Variable Air Conditioners Cassette Type Indoor Unit

3.3.2 Selection of Communication Wire Between Indoor Unit and Indoor Unit (or outdoor unit)

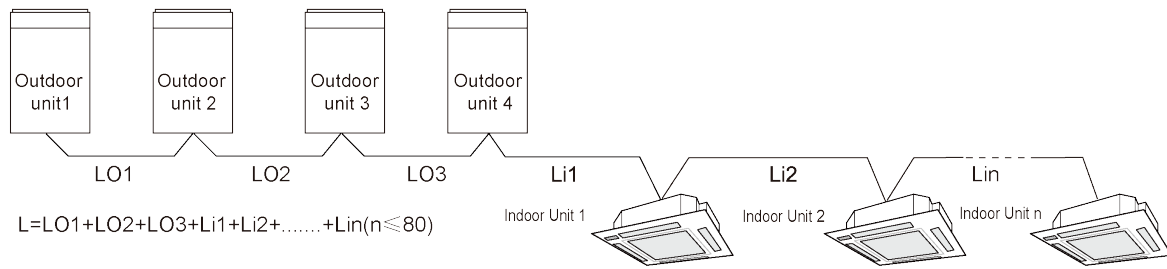

Fig.3.3.2

Wire type	Total length of communication wire between indoor unit and indoor unit(outdoor unit) (m)	Wire diameter (mm ²)	Wire standard	Remark
Light/normal PVC hose	$L \leq 1000$	$\geq 2 \times 0.75$	IEC 60227-5	1. If the wire diameter is enlarged to $2 \times 1 \text{mm}^2$, the total communication length line can reach 1500m. 2. The cord shall be Circular cord (the cores shall be twisted together). 3. If unit is installed in places with intense magnetic field or strong interference, it is necessary to use shielded wire.

3.4 Wiring Requirement

Dimension of power cord and capacity of air switch.

Model	Power Cord Size	Air Switch Capacity (A)	Minimum Sectional Area of Ground Wire (mm ²)	Minimum Sectional Area of Power Cord (mm ²)
GMV-ND28T/A-T	220-240V-1ph-50Hz 208-230V-1ph-60Hz	6	1.0	1.0
GMV-ND36T/A-T		6	1.0	1.0
GMV-ND45T/A-T		6	1.0	1.0
GMV-ND50T/A-T		6	1.0	1.0
GMV-ND56T/A-T		6	1.0	1.0
GMV-ND63T/A-T		6	1.0	1.0
GMV-ND71T/A-T		6	1.0	1.0
GMV-ND80T/A-T		6	1.0	1.0
GMV-ND90T/A-T		6	1.0	1.0
GMV-ND100T/A-T		6	1.0	1.0
GMV-ND112T/A-T		6	1.0	1.0
GMV-ND125T/A-T		6	1.0	1.0
GMV-ND140T/A-T		6	1.0	1.0
GMV-ND160T/A-T		6	1.0	1.0

! NOTES!

- ① An all-pole disconnection switch having a contact separation of at least 3mm in all poles should be connected in fixed wiring.
- ② The circuit breaker and power cord specification in above sheet is based on max power (max current) of the unit.
- ③ The power cord specification in above sheet is based on ambient temperature of 40°C.

- ④ If the supply cord is damaged, it must be replaced by the manufacturer or its service agent or a similarly qualified person in order to avoid a hazard.
- ⑤ The circuit breaker specification in above sheet is based on ambient temperature of 40°C. If the working condition is different, please adjust it according to the specification sheet of circuit breaker.

4 Installation Instructions

4.1 Indoor Unit Installation

4.1.1 Ceiling Opening Dimension and Suspension Bolt Position.

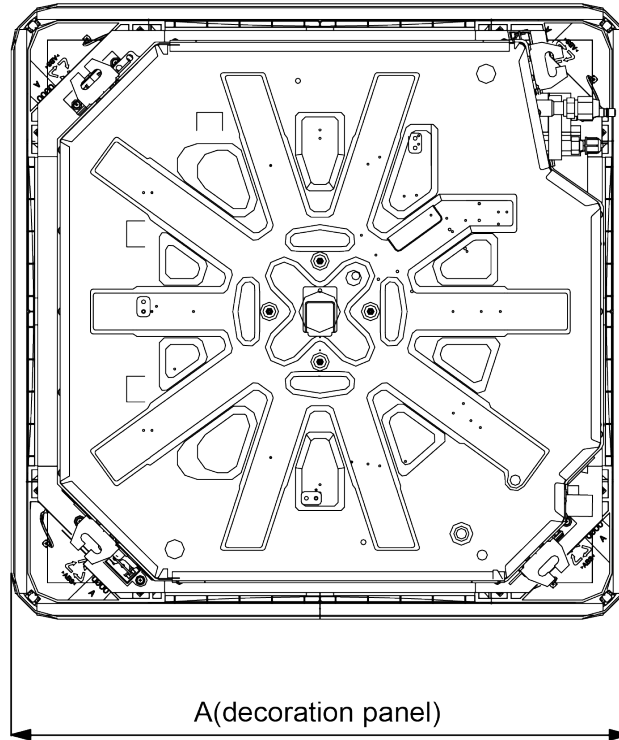
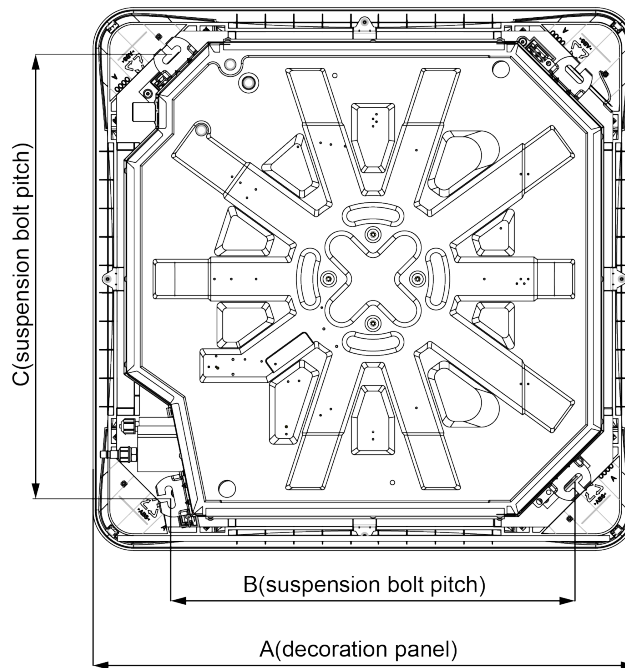

Fig.4.1.1

Unit: mm

Model	A
GMV-ND28~140T/A-T	950



Unit: mm

Model	A	B	C
GMV-ND160T/A-T	1040	790	840

4.1.2 Suspend The Indoor Unit

(1) Drill bolt holes and install bolts.

1) Stick the reference cardboard on the installation position. Drill 4 holes according to the hole site on the cardboard as shown in Fig.4.1.3. diameter of drilling hole is according to the diameter of expansion bolt and the depth is 60-70mm, as shown in Fig.4.1.4.

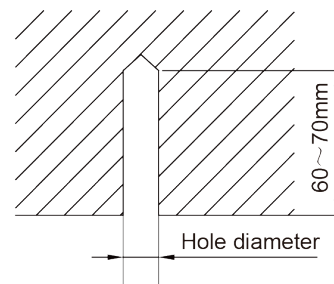
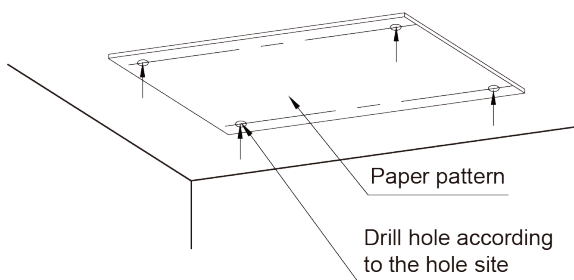

2) Insert the M10 expansion bolt into the hole and then knock the nail into the bolt, as shown in Fig.4.1.5.

NOTE! The length of bolt depends on the installation height of the unit, bolts are field supplied.

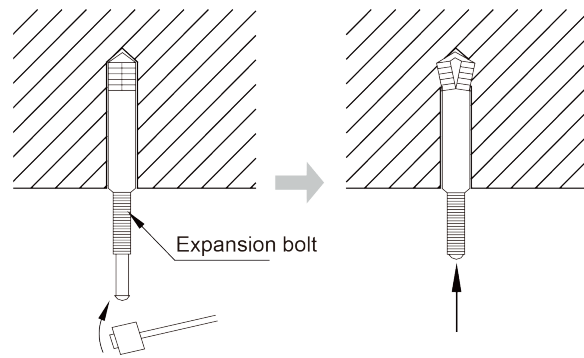

Fig.4.1.5

(2) Install the indoor unit temporarily.

Assemble suspension bolt on the expansion bolt, attach the hanger bracket to the suspension bolt. Be sure to fix it securely by using a nut and washer from upper and lower sides of the hanger bracket. The washer fixing plate will prevent the washer from falling.

(3) The usage of paper pattern.

Refer to paper pattern of installation for ceiling opening dimension. The center of ceiling opening is indicated on the paper pattern. Fix the paper pattern to the unit with 4 screws and fix the corners of the waterspout at the drainage pipe by screws.

(4) Adjust the unit to the right position.

(5) Check the level of the unit.

The indoor unit is equipped with build-in water pump and float switch, verify the levelness of 4 directions by level gauge or vinyl tube (filled with water) respectively.

(6) Remove the washer locating plate and then tighten the nut on it.

(7) Remove the paper pattern.

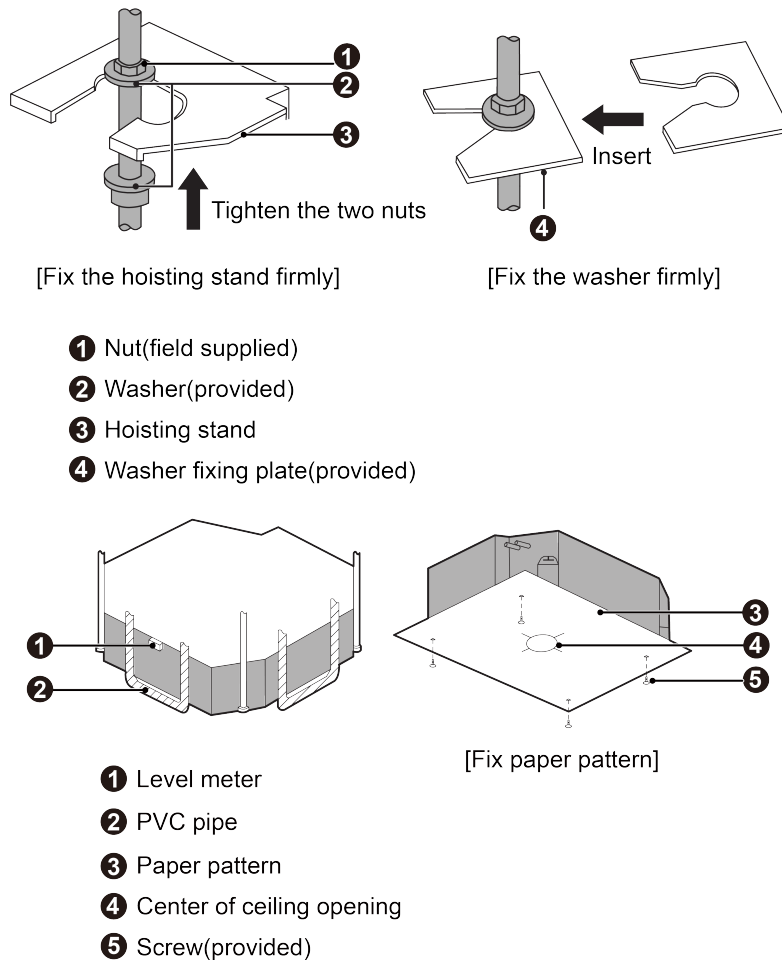

Fig.4.1.6

4.2 Refrigerant Pipe Connection

- (1) Aim the flaring port of copper pipe at the center of screwed joint and then tighten the flaring nut with hand as shown in Fig.4.2.
- (2) Tighten the flaring nut with torque wrench.

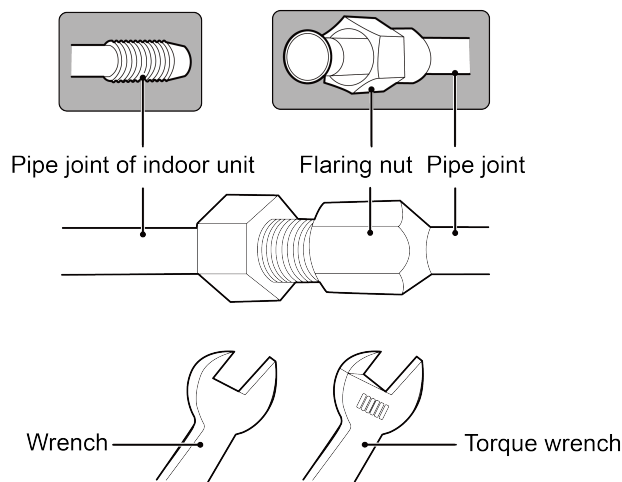

Fig.4.2

Torque for tightening nut	
Pipe diameter (mm)	Torque (N·m)
Φ6.35	15~30
Φ9.52	35~40
Φ12.7	45~50
Φ15.9	60~65
Φ19.05	70~75

(3) Use pipe bend when bending the pipe and the bending angle should not be too small.

(4) Wrap the connection pipe and joint with sponge and then tie them firmly with tape.

4.3 Drainage Pipe Installation and Drainage System Testing

4.3.1 Notice for Installation of Drain Pipe

(1) It is not allowed to connect the condensate drain pipe into waste pipe or other pipelines which are likely to produce corrosive or peculiar smell to prevent the smell from entering indoors or corrupt the unit.

(2) It is not allowed to connect the condensate drain pipe into rain pipe to prevent rain water from pouring in and cause property loss or personal injury.

(3) Condensate drain pipe should be connected into special drain system for air conditioner.

(4) The drainage pipe should be short and the gradient downwards should be at least 1%~2% in order to drain condensation water smoothly.

(5) The diameter of drainage hose should be bigger or equal to the diameter of drainage pipe joint.

(6) Install drainage pipe according to the following fig and arrange insulation to the drainage pipe. Improper installation may lead to water leakage and damp the furniture and other things in the room.

(7) You can buy normal hard PVC pipe used as the drainage pipe. During connection, insert the end of PVC pipe into the drainage hole and then tighten it with drainage hole and wire binder. Can't connect the drainage hole and drainage hole with glue.

(8) When the drainage pipelines are used for several units, the position of pipeline should be about 100mm lower than the drainage port of each unit. In this case, thicker pipes should be applied.

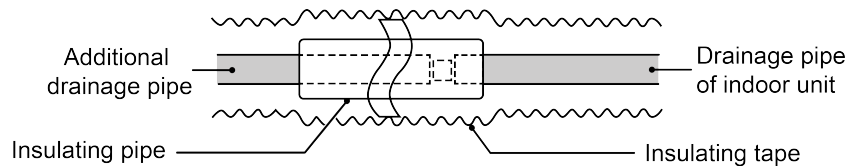

Fig.4.3.1

4.3.2 Drainage Pipe Installation

(1) Drainage pipe should have the same diameter or larger diameter than the connecting pipes (PVC pipe, outside diameter 25mm, thickness≥1.5mm).

(2) Keep drainage pipe short and sloping downwards at a gradient of at least 1% for preventing forming air bubbles.

(3) If the gradient of drainage pipe could not meet the installation requirements, raising pipe should be applied.

(4) Insert the drainage hose into drain socket, tighten the metal clamp securely.

(5) Warp the sealing pad over drain hose and metal clamp for heat insulation.

Multi Variable Air Conditioners Cassette Type Indoor Unit

- (6) Make sure to perform insulation work for all drainage piping in order to prevent any possible water drop due to dew condensation.
- (7) Apply the suitable diameter for converging drainage pipe according to the operating capacity of the unit.

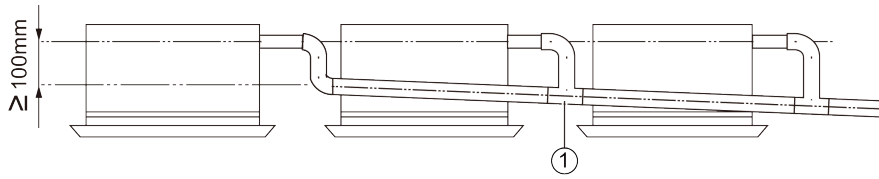
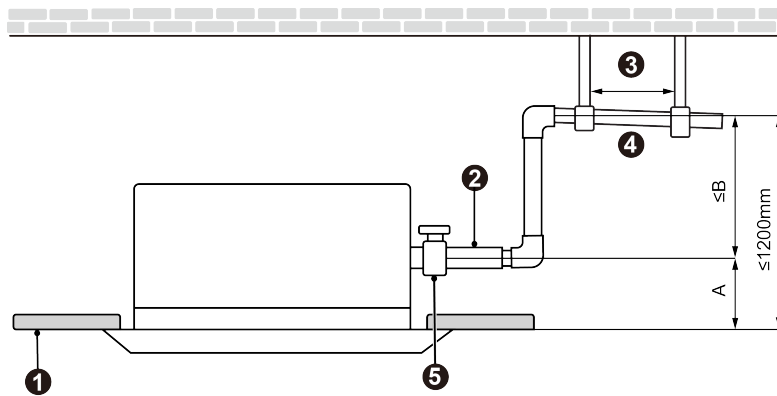

Fig.4.3.2

- ① Drainage pipes assembled by T-shaped joints.

- (8) The installation height of raising pipe for drainage should be lower than B. The gradient from raising pipe towards drainage direction should be at least 1%~2%. If the raising pipe is vertical with the unit, the raising height should be less than C, as shown in Fig.4.3.3.



- ① Ceiling
- ② The drainage pipe provided in the annex is not allowed to bend
- ③ Hanger bracket 1000-1500mm
- ④ Drainage pipe
- ⑤ Metal clamp

Fig.4.3.3

Unit:mm

Model	A	B	C
GMV-ND28~50T/A-T	170	1030	980
GMV-ND56~160T/A-T	220	980	930

- (9) Drain pipes should have a downward slope of at least 1%~2%, in order to prevent pipes from sagging, install hanger bracket at intervals of 1000~1500mm.

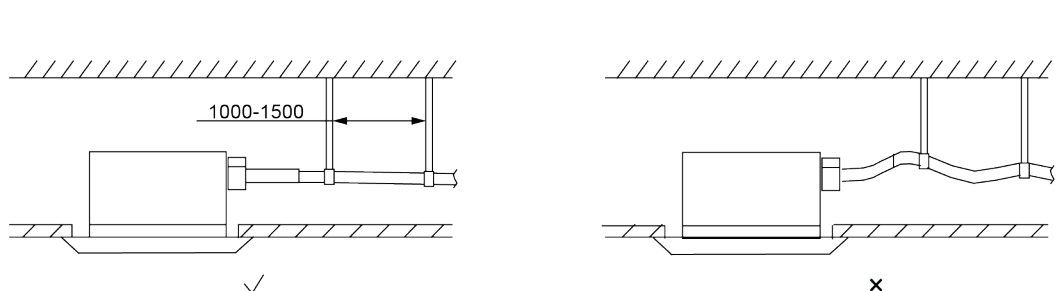

Unit:mm

Fig.4.3.4

- (10) During the installation, distance from soft drain pipe to the gasket is C when the bolt is tightened. It is not allowed to apply PVC or other related glue in the joints of two ends of drain pipe.

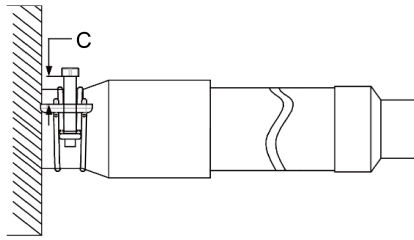

Fig.4.3.5

Unit:mm

Model	C
GMV-ND28~50T/A-T	10±3
GMV-ND56~160T/A-T	15±3

4.3.3 Test of Drainage System

- (1) Please test drainage system after electric work is finished.

Inject approximately 1L purified water to drain pan from air vent, ensure that not to splash the water over the electrical components (e.g. water pump etc.).

- 1) In case of commissioning finished, please energize the IDUs and switch to cooling or dry mode, meanwhile, the water pump operates, you can check the draining through the transparent part of drain socket.
- 2) If communication wire is not connected, communication malfunction "C0" will occur after 60s of energizing. In this case, the water pump operates automatically. Check if the water pump drains normally through drainage port. The water pump will stop automatically after running for 10min.

- (2) During the test, please carefully check the drainage joint, make sure no any leakage occur.

- (3) It's strongly recommend to do the drain test before ceiling decoration.

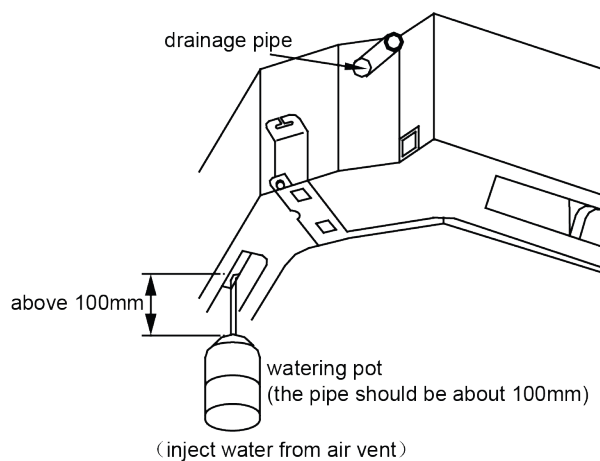

Fig.4.3.6

4.4 Panel Installation

4.4.1 Notices for Installation

(1) Improper decorative panel installation could cause the following problems.

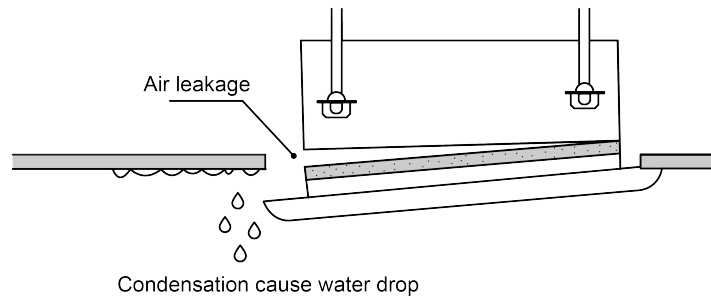

Fig.4.4.1

(2) Ensure that its clearance-free between decoration panel and ceiling board after installation, if not, please adjust the body position.

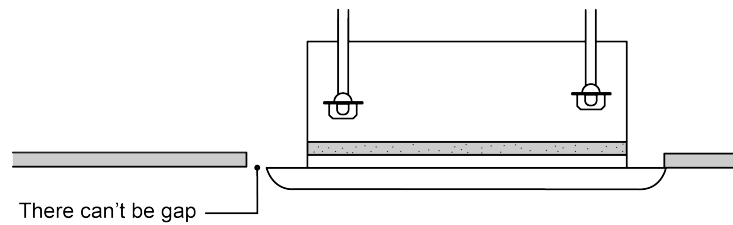

Fig.4.4.2

(3) Connect the decoration panel terminals (Female) to body terminals (Male) as shown in Fig.4.4.3.

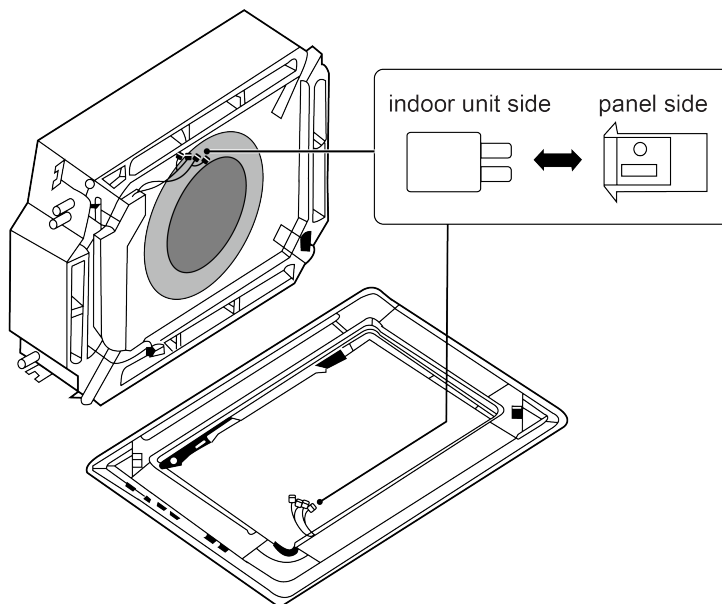

Fig.4.4.3

4.4.2 Panel Installation

- (1) Detach the panel's Corner Cap, there is a mark "piping side" on one of the 4 corners, adjust the panel direction so as to keep the mark and fittings on the same corner.
- (2) Temporarily hang the panel to body (there is four hangers on each corner of the panel, hang the hangers to corresponding hooks on the body), as shown in Fig.4.4.4.
- (3) Detach the air inlet grille from panel, make a wiring connection of signal receiver. Notices that the connection wire not stuck in the middle of body and panel, or may cause air leakage and lead to condensation water drop.
- (4) Tighten 4 screws at each corner of panel respectively, fix the panel on the body firmly.
- (5) After tightening screws, reinstall the air inlet grille.

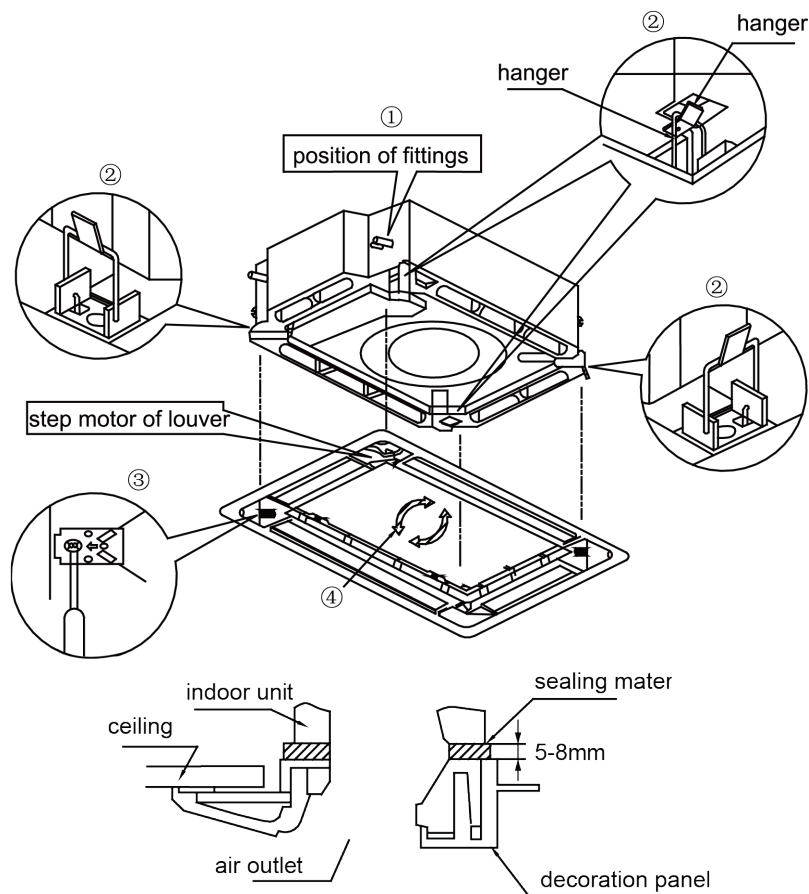

Fig.4.4.4

4.5 Wired Controller Installation

Wired controller is optional accessory. If wired controller is needed, please contact your local dealer and install the wired controller according to the instruction manual.

! NOTE! Do perform the commissioning operation before first use, automatic addressing or other settings, please refer to the manual of ODU.

5 Wiring Work



WARNING!

Before obtaining access to terminals, all supply circuits must be disconnected.

- ① Units must be earthed securely, or it may cause electric shock.
- ② Please carefully read the wiring diagram before carry out the wiring work, incorrect wiring could cause malfunction or even damage the unit.
- ③ The unit should be powered by independent circuit and specific socket.
- ④ The wiring should be in accordance with related regulations in order to ensure the units reliable running.
- ⑤ Install circuit breaker for branch circuit according to related regulations and electrical standards.
- ⑥ Keep cable away from refrigerant piping, compressor and fan motor.
- ⑦ The communication wires should be separated from power cord and connection wire between indoor unit and outdoor unit.
- ⑧ Adjust the static pressure via wired controller according to site circumstance.

5.1 Connection of Wire and Patch Board Terminal

(1) The connection of wire (as shown in Fig.5.1.1).

- 1) Strip about 25mm insulation of the wire end by stripping and cutting tool.
- 2) Remove the wiring screws on the terminal board.
- 3) Shape the tail of wire into ring by needle nose plier, and keep the gauge of ring in accordance with screw.
- 4) Use the screwdriver for tightening the terminal.

(2) The connection of stranded wire (as shown in Fig.5.1.2).

- 1) Strip about 10mm insulation of the end of stranded wire by stripping and cutting tool.
- 2) Loosen the wiring screws on terminal board.
- 3) Insert the wire into the ring tongue terminal and tighten by crimping tool.
- 4) Use the screwdriver for tightening the terminal.

Unit:mm

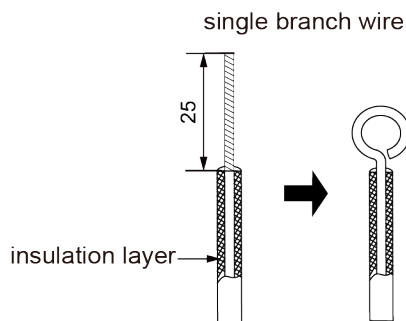

Fig.5.1.1

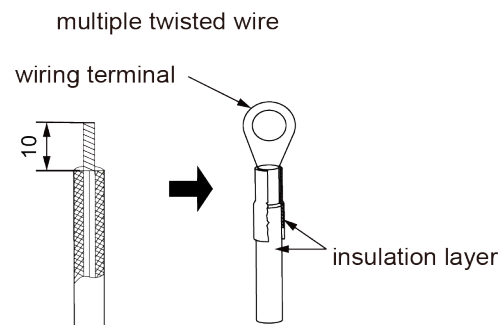

Fig.5.1.2

5.2 Power Cord Connection

! NOTES!

- ① Every unit should be equipped with a circuit breaker for short-circuit and overload protection.
- ② During operation, all indoor units connected to the same outdoor unit system must be kept energized status. Otherwise, the unit can't operate normally.

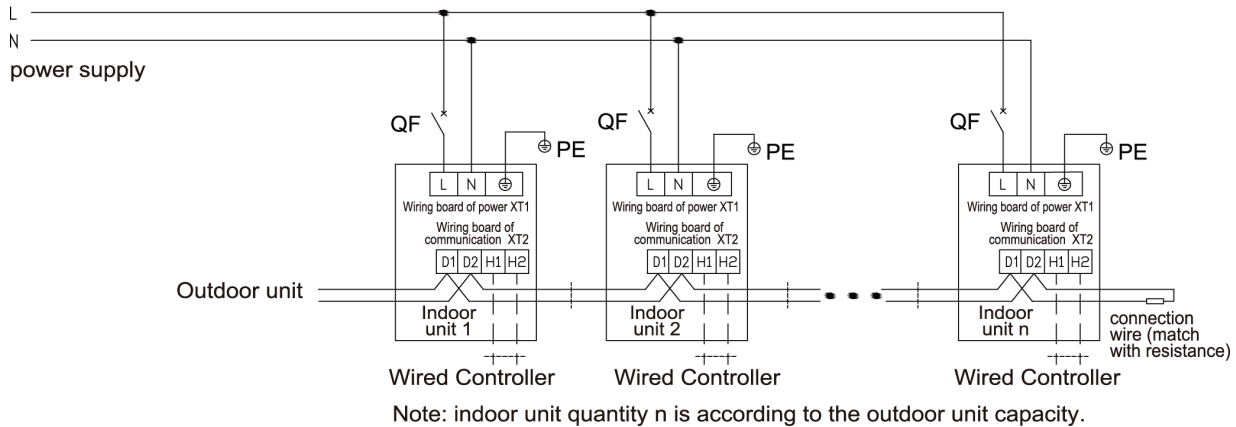

Fig.5.2

For units with single-phase power supply.

- (1) Detach the electric box lid.
- (2) Let the power cord pass through the wiring through-holes.
- (3) Connect the power cord to terminal "L, N".
- (4) Fix the power cord with wiring clamp.

5.3 Connection of Communication Wire between Indoor Unit and Outdoor Unit (or indoor unit)

- (1) Detach the electric box lid.
- (2) Let the Communication cable pass through the wiring through-holes.
- (3) Connect the communication wire to terminal D1 and D2 of indoor 4-bit wiring board, as shown in Fig.5.3.1.

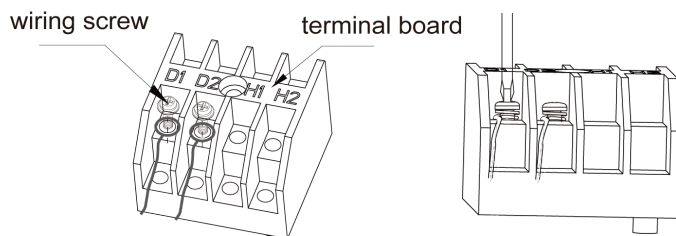

Fig.5.3.1

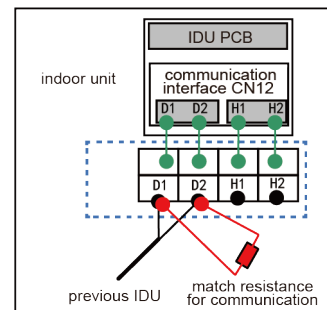

Fig.5.3.2

- (4) Fix the communication cable with clamp of electric box.
- (5) For more reliable communication, make sure connect the terminal resistor to the most downstream IDU of the communication bus (terminal D1 and D2), as shown in Fig 5.3.2, terminal resistor is provided with each ODU.

5.4 Connection of Communication Wire for Wired Controller

- (1) Detach the electric box lid.
- (2) Let the communication wire pass through the wiring through-holes.
- (3) Connect the communication wire to terminal H1 and H2 of indoor 4-bit wiring board.
- (4) Fix the communication wire with clamp.
- (5) Wiring instructions of signal receiver and wired controller.

1) Wired controller is shown as Fig.5.4.1, wireless controller is shown as Fig.5.4.2, signal receiver is provided with panel as standard accessory.

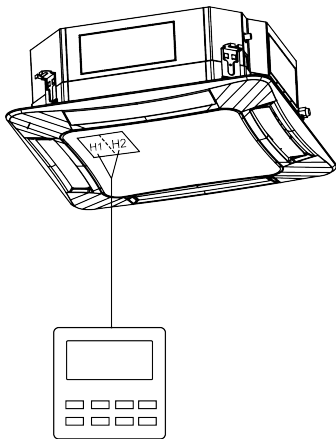

Fig.5.4.1

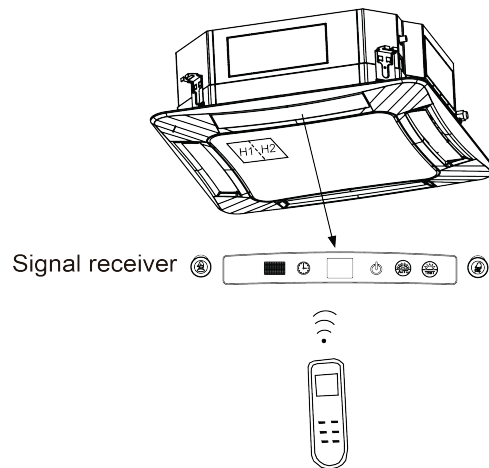

Fig.5.4.2

2) Both IDU and wired controller are equipped with signal receiver, and available for wireless control respectively.

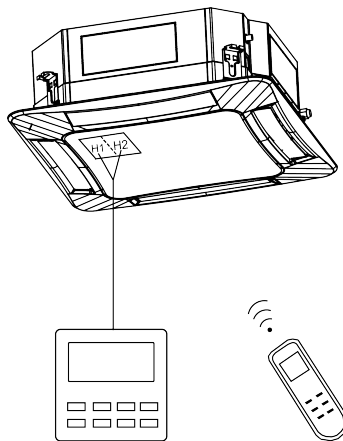

Fig.5.4.3

5.5 Instructions on Connecting Wired Controller and Indoor Units Network

- (1) Communication wire of indoor unit and outdoor unit (or indoor unit) is connected to D1, D2.
- (2) Wired controller is connected to H1, H2.
- (3) One indoor unit can connect two wired controllers that must be set as master one and slave one.
- (4) One wired controller can control 16 indoor units in maximum at the same time (as shown in Fig.5.5).

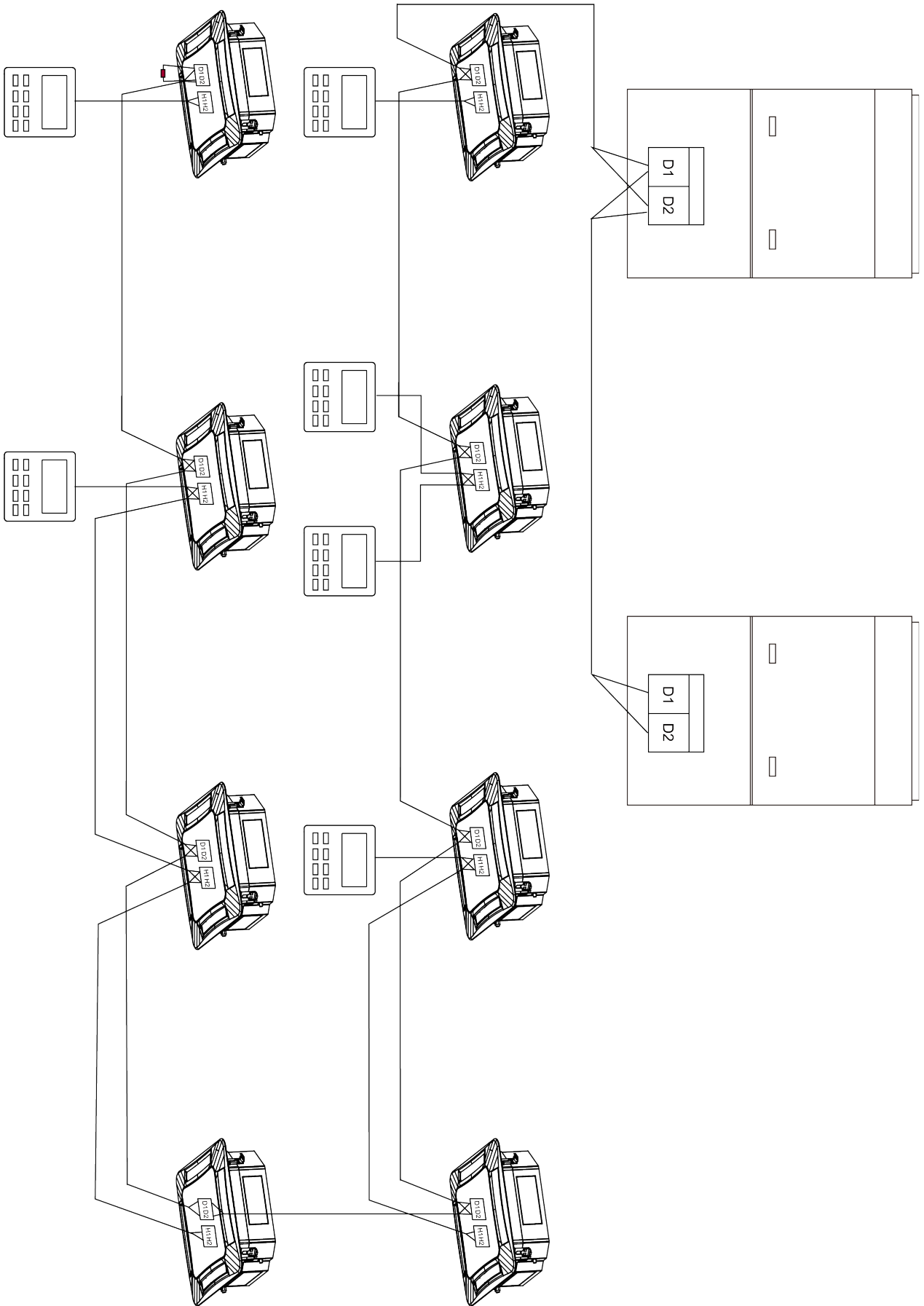

Fig.5.5

NOTES!

- ① The type of indoor units must be the same if they are controlled by the same wired controller.
- ② When the indoor unit is controlled by two wired controllers, the addresses of the two wired controllers should be different through address setting. Address 1 is for main controller; Address 2 is for slave controller. Detailed setting please refer to the instruction manual of wired controller.

6 Routine Maintenance

WARNING!

- ① Do not turn off the unit and cut off the main power supply when cleaning the air conditioner to avoid electric shock or injury.
- ② Stand at solid table when cleaning the unit.
- ③ Do not clean the unit with hot water whose temperature is higher than 45°C to prevent fade or deformation.
- ④ Do not dry the filters by fire, or it may catch fire or become deformed.
- ⑤ Clean the filter with a wet cloth dipped in neutral detergent.
- ⑥ Please contact after-sales service staff if there is abnormal situation.

6.1 Cleaning of Filter

- (1) Remove the filters from inlet of IDU. Use a vacuum cleaner to remove dust. If the filters are dirty, wash them with warm water and mild detergent, and dry the filters in the shade.
- (2) If the unit used in the environment with much dust, please clean it regularly (usually once every two weeks).

6.2 Maintenance Before The Seasonal Use

- (1) Check if the air inlet and air outlet of indoor and outdoor unit are blocked.
- (2) Check if securely grounded.
- (3) Check if all the power cord and communication cable are securely connected.
- (4) Check if any error code displayed after energized.

6.3 Maintenance After The Seasonal Use

- (1) Set the unit in fan mode for half a day in a sunny day to dry the inner part of unit.
- (2) When the unit won't be used for a long time, please cut off power supply for energy saving. the characters on the wired controller screen will disappear after cutting off the power supply.

7 Table of Error Codes for Indoor Unit

Error Code	Content	Error Code	Content	Error Code	Content
L0	Indoor Unit Error	LA	Indoor Units Incompatibility Error	d9	Jumper Cap Error
L1	Indoor Fan Protection	LH	Low Air Quality Warning	dA	Indoor Unit Network Address Error
L2	E-heater Protection	LC	ODU-IDU Incompatibility Error	dH	Wired Controller PCB Error
L3	Water Full Protection	d1	Indoor Unit PCB Error	dC	Capacity DIP Switch Setting Error
L4	Wired Controller Power Supply Error	d3	Ambient Temperature Sensor Error	dL	Outlet Air Temperature Sensor Error
L5	Freeze protection	d4	Inlet Pipe Temperature Sensor Error	dE	Indoor Unit CO ₂ Sensor Error
L7	No Master Indoor Unit Error	d6	Outlet Pipe Temperature Sensor Error	dy	Water Temperature Sensor Error
L8	Power Insufficiency Protection	d7	Humidity Sensor Error	C0	Communication Error
L9	Quantity Of Group Control Indoor Units Setting Error	d8	Water Temperature Error	AJ	Filter Cleaning Reminder
db	Special Code: Field Debugging Code				

8 Troubleshooting

The air conditioner is not expected to be serviced by users. Incorrect repair may cause electric shock or fire, so please contact an authorized service center for professional service. The following checks prior to contact may save your time and money.

Phenomenon	Troubleshooting
The unit can't start.	<ul style="list-style-type: none"> ① Power supply is not connected. ② Circuit breaker tripping caused by leakage of electricity. ③ Input voltage is too low. ④ Defect of main PC-board.
The unit stops after running for a while.	<ul style="list-style-type: none"> ① The inlet or outlet of ODU or IDU is blocked by obstacle.
Poor cooling effect.	<ul style="list-style-type: none"> ① The filter is dirty. ② Too heavy heat load of room (e.g. too many people). ③ Door or windows is open. ④ Inlet and outlet of IDU are blocked. ⑤ Setting temperature is too high. ⑥ Refrigerant is insufficient (e.g. refrigerant leakage).
Poor heating effect.	<ul style="list-style-type: none"> ① The filter is dirty. ② Door or window is open. ③ Setting temperature is too low. ④ Refrigerant is insufficient (e.g. refrigerant leakage).
Indoor fan doesn't start up during heating.	<ul style="list-style-type: none"> ① At starting, the IDU fan could not operate till the heat exchange become hot, for preventing delivering the cool air. ② At defrosting, the IDU fan stopped due to system switch to cooling mode. For preventing delivering the cool air, and resume operating after defrosting.

! **NOTE!** If air conditioner still fails to work normally after checking and handling as described above, please stop using it immediately and contact local service center for assistance.

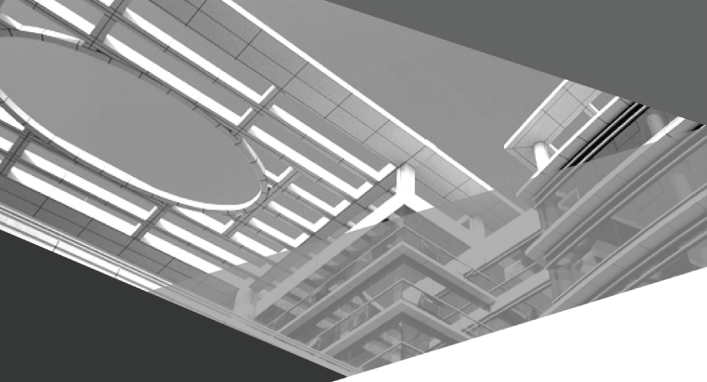

GREE ELECTRIC APPLIANCES, INC. OF ZHUHAI

Add: West Jinji Rd, Qianshan, Zhuhai, Guangdong, China, 519070

Tel: (+86-756) 8522218

Fax: (+86-756) 8669426

E-mail: global@cn.gree.com www.gree.com



66174100035