

9.3.4 U8 Malfunction

Possible causes:

1. The controller diagnoses incorrectly due to instant energization after de-energized while the capacitor discharges slowly;
2. Malfunction of the zero-cross detection circuit of the mainboard.

See the flow chart below:

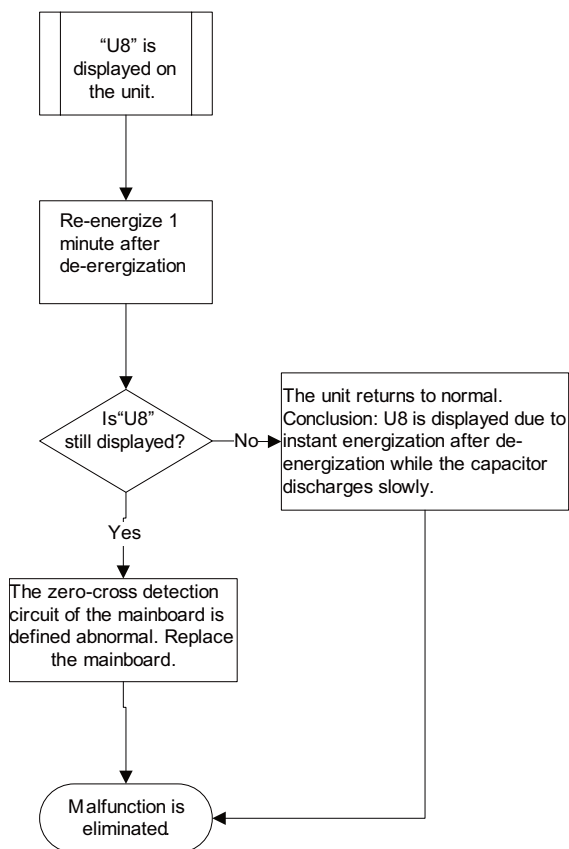

Appendix 1: Resistance Table for Indoor and Outdoor Ambient Temperature Sensors (15K)							
Temp.(°C)	Resistance(kΩ)	Temp.(°C)	Resistance (kΩ)	Temp.(°C)	Resistance(kΩ)	Temp(°C)	Resistance(kΩ)
-19	138.1	20	18.75	59	3.848	98	1.071
-18	128.6	21	17.93	60	3.711	99	1.039
-17	121.6	22	17.14	61	3.579	100	1.009
-16	115	23	16.39	62	3.454	101	0.98
-15	108.7	24	15.68	63	3.333	102	0.952
-14	102.9	25	15	64	3.217	103	0.925
-13	97.4	26	14.36	65	3.105	104	0.898
-12	92.22	27	13.74	66	2.998	105	0.873
-11	87.35	28	13.16	67	2.896	106	0.848
-10	82.75	29	12.6	68	2.797	107	0.825
-9	78.43	30	12.07	69	2.702	108	0.802
-8	74.35	31	11.57	70	2.611	109	0.779
-7	70.5	32	11.09	71	2.523	110	0.758
-6	66.88	33	10.63	72	2.439	111	0.737
-5	63.46	34	10.2	73	2.358	112	0.717
-4	60.23	35	9.779	74	2.28	113	0.697
-3	57.18	36	9.382	75	2.206	114	0.678
-2	54.31	37	9.003	76	2.133	115	0.66
-1	51.59	38	8.642	77	2.064	116	0.642
0	49.02	39	8.297	78	1.997	117	0.625
1	46.6	40	7.967	79	1.933	118	0.608
2	44.31	41	7.653	80	1.871	119	0.592
3	42.14	42	7.352	81	1.811	120	0.577
4	40.09	43	7.065	82	1.754	121	0.561
5	38.15	44	6.791	83	1.699	122	0.547
6	36.32	45	6.529	84	1.645	123	0.532
7	34.58	46	6.278	85	1.594	124	0.519
8	32.94	47	6.038	86	1.544	125	0.505
9	31.38	48	5.809	87	1.497	126	0.492
10	29.9	49	5.589	88	1.451	127	0.48
11	28.51	50	5.379	89	1.408	128	0.467
12	27.18	51	5.197	90	1.363	129	0.456
13	25.92	52	4.986	91	1.322	130	0.444
14	24.73	53	4.802	92	1.282	131	0.433
15	23.6	54	4.625	93	1.244	132	0.422
16	22.53	55	4.456	94	1.207	133	0.412
17	21.51	56	4.294	95	1.171	134	0.401
18	20.54	57	4.139	96	1.136	135	0.391
19	19.63	58	3.99	97	1.103	136	0.382

Appendix 2: Resistance Table for Indoor and Outdoor Tube Temperature Sensor (20K)

Temp.(°C)	Resistance (kΩ)	Temp. (°C)	Resistance (kΩ)	Temp. (°C)	Resistance (kΩ)	Temp. (°C)	Resistance (kΩ)
-19	181.4	20	25.01	59	5.13	98	1.427
-18	171.4	21	23.9	60	4.948	99	1.386
-17	162.1	22	22.85	61	4.773	100	1.346
-16	153.3	23	21.85	62	4.605	101	1.307
-15	145	24	20.9	63	4.443	102	1.269
-14	137.2	25	20	64	4.289	103	1.233
-13	129.9	26	19.14	65	4.14	104	1.198
-12	123	27	18.13	66	3.998	105	1.164
-11	116.5	28	17.55	67	3.861	106	1.131
-10	110.3	29	16.8	68	3.729	107	1.099
-9	104.6	30	16.1	69	3.603	108	1.069
-8	99.13	31	15.43	70	3.481	109	1.039
-7	94	32	14.79	71	3.364	110	1.01
-6	89.17	33	14.18	72	3.252	111	0.983
-5	84.61	34	13.59	73	3.144	112	0.956
-4	80.31	35	13.04	74	3.04	113	0.93
-3	76.24	36	12.51	75	2.94	114	0.904
-2	72.41	37	12	76	2.844	115	0.88
-1	68.79	38	11.52	77	2.752	116	0.856
0	65.37	39	11.06	78	2.663	117	0.833
1	62.13	40	10.62	79	2.577	118	0.811
2	59.08	41	10.2	80	2.495	119	0.77
3	56.19	42	9.803	81	2.415	120	0.769
4	53.46	43	9.42	82	2.339	121	0.746
5	50.87	44	9.054	83	2.265	122	0.729
6	48.42	45	8.705	84	2.194	123	0.71
7	46.11	46	8.37	85	2.125	124	0.692
8	43.92	47	8.051	86	2.059	125	0.674
9	41.84	48	7.745	87	1.996	126	0.658
10	39.87	49	7.453	88	1.934	127	0.64
11	38.01	50	7.173	89	1.875	128	0.623
12	36.24	51	6.905	90	1.818	129	0.607
13	34.57	52	6.648	91	1.736	130	0.592
14	32.98	53	6.403	92	1.71	131	0.577
15	31.47	54	6.167	93	1.658	132	0.563
16	30.04	55	5.942	94	1.609	133	0.549
17	28.68	56	5.726	95	1.561	134	0.535
18	27.39	57	5.519	96	1.515	135	0.521
19	26.17	58	5.32	97	1.47	136	0.509

Appendix 3: Resistance Table for Outdoor Discharge Temperature Sensor (50K)							
Temp. (°C)	Resistance (kΩ)	Temp. (°C)	Resistance (kΩ)	Temp. (°C)	Resistance (kΩ)	Temp. (°C)	Resistance (kΩ)
-29	853.5	10	98	49	18.34	88	4.754
-28	799.8	11	93.42	50	17.65	89	4.609
-27	750	12	89.07	51	16.99	90	4.469
-26	703.8	13	84.95	52	16.36	91	4.334
-25	660.8	14	81.05	53	15.75	92	4.204
-24	620.8	15	77.35	54	15.17	93	4.079
-23	580.6	16	73.83	55	14.62	94	3.958
-22	548.9	17	70.5	56	14.09	95	3.841
-21	516.6	18	67.34	57	13.58	96	3.728
-20	486.5	19	64.33	58	13.09	97	3.619
-19	458.3	20	61.48	59	12.62	98	3.514
-18	432	21	58.77	60	12.17	99	3.413
-17	407.4	22	56.19	61	11.74	100	3.315
-16	384.5	23	53.74	62	11.32	101	3.22
-15	362.9	24	51.41	63	10.93	102	3.129
-14	342.8	25	49.19	64	10.54	103	3.04
-13	323.9	26	47.08	65	10.18	104	2.955
-12	306.2	27	45.07	66	9.827	105	2.872
-11	289.6	28	43.16	67	9.489	106	2.792
-10	274	29	41.34	68	9.165	107	2.715
-9	259.3	30	39.61	69	8.854	108	2.64
-8	245.6	31	37.96	70	8.555	109	2.568
-7	232.6	32	36.38	71	8.268	110	2.498
-6	220.5	33	34.88	72	7.991	111	2.431
-5	209	34	33.45	73	7.726	112	2.365
-4	198.3	35	32.09	74	7.47	113	2.302
-3	199.1	36	30.79	75	7.224	114	2.241
-2	178.5	37	29.54	76	6.998	115	2.182
-1	169.5	38	28.36	77	6.761	116	2.124
0	161	39	27.23	78	6.542	117	2.069
1	153	40	26.15	79	6.331	118	2.015
2	145.4	41	25.11	80	6.129	119	1.963
3	138.3	42	24.13	81	5.933	120	1.912
4	131.5	43	23.19	82	5.746	121	1.863
5	125.1	44	22.29	83	5.565	122	1.816
6	119.1	45	21.43	84	5.39	123	1.77
7	113.4	46	20.6	85	5.222	124	1.725
8	108	47	19.81	86	5.06	125	1.682
9	102.8	48	19.06	87	4.904	126	1.64

Note: The information above is for reference only.

10. Removal Procedure

10.1 Removal Procedure of Indoor Unit

⚠ Warning Be sure to wait for a minimum of 10 minutes after turning off all power supplies before disassembly.

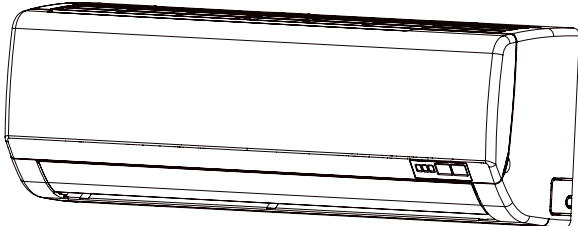
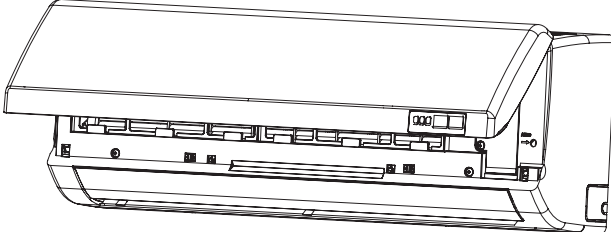
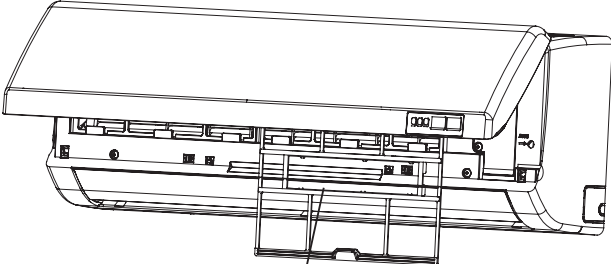
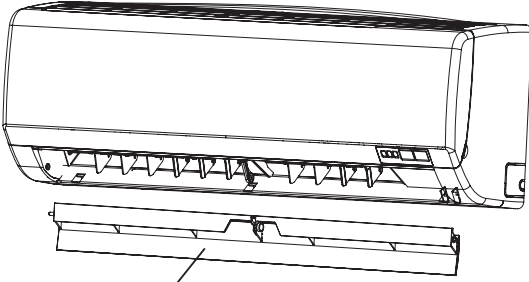
Steps	Procedure
1. Before disassembly	
2. Removal of filter and horizontal louver	<p data-bbox="151 1070 491 1099">1 Open the front panel .</p>  <p data-bbox="151 1397 751 1451">2 Push the filter inward and then draw it upward to remove it.</p>  <p data-bbox="1086 1576 1142 1606">Filter</p> <p data-bbox="151 1671 751 1749">3 Remove axial sleeve of horizontal louver and bend the louver slightly. Then remove the louver.</p>  <p data-bbox="895 1962 1070 1991">Horizontal louver</p>

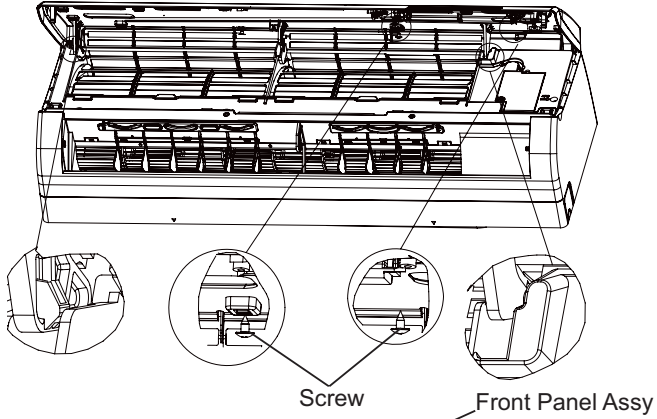
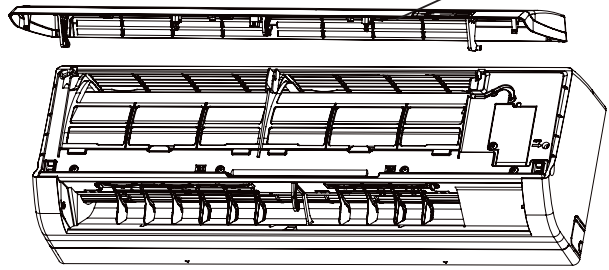
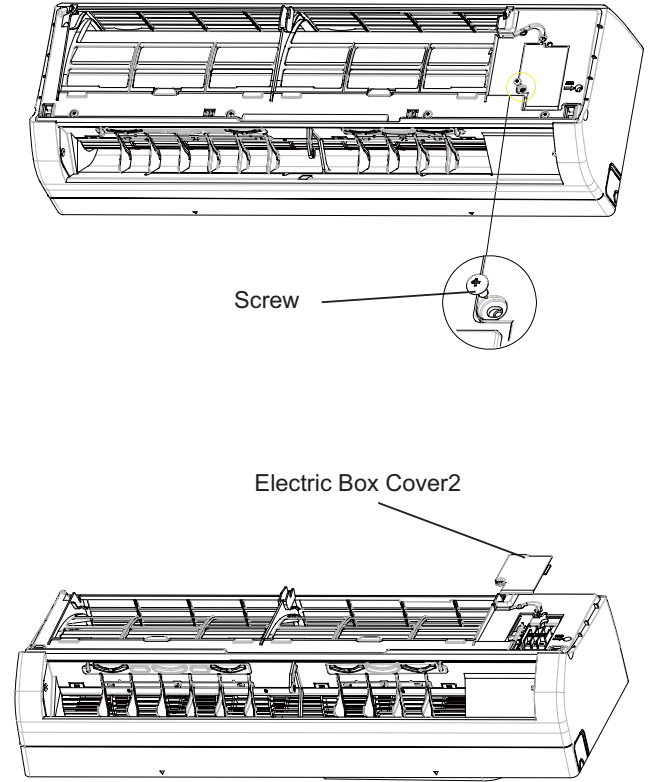
Steps	Procedure	
3. Removal of indicator and front panel		
1	Remove connection screw of indicator and then remove the indicator.	 <p>Screw</p> <p>Front Panel Assy</p>
2	Remove rotating shaft of front panel and then remove the front panel.	
4. Removal of electric box cover 2		
	Remove connection screws between electric box cover 2 and front case. Then remove the electric box cover 2.	 <p>Screw</p> <p>Electric Box Cover2</p>

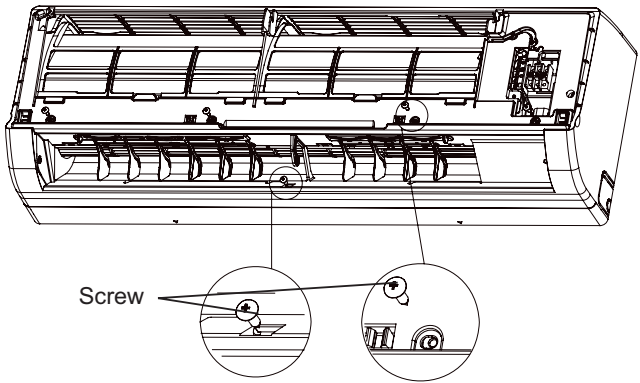
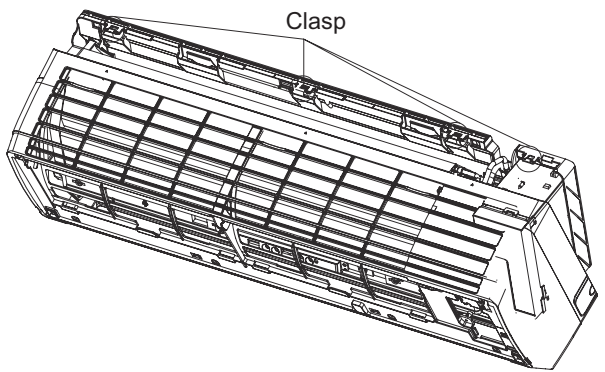
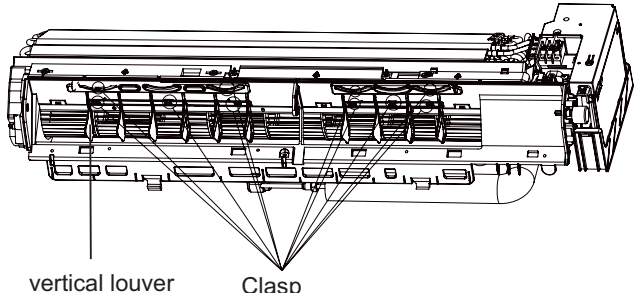
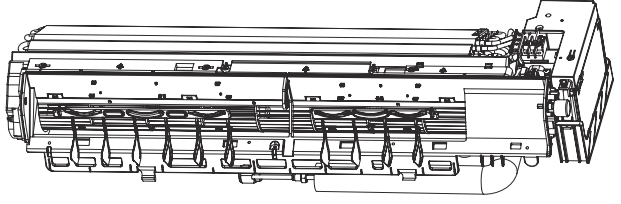
Steps	Procedure
5. Removal of front case	
1	<p>Remove connection screws between front case and rear case.</p> 
2	<p>Release clasp connecting front case and rear case and then remove the front case.</p> 
6. Removal of vertical louver	
1	<p>Remove 10 clasps of vertical louver and rear case assy.</p> 
2	<p>Remove vertical louver.</p> 

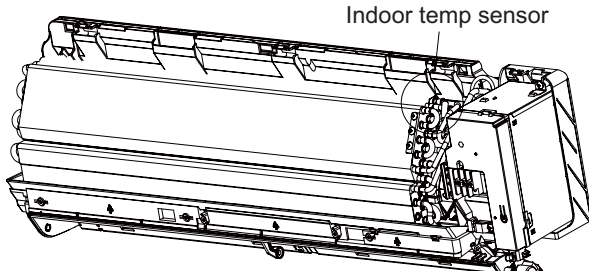
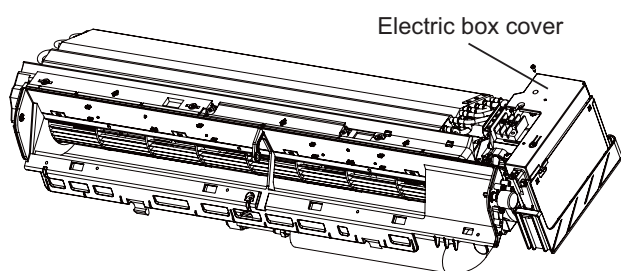
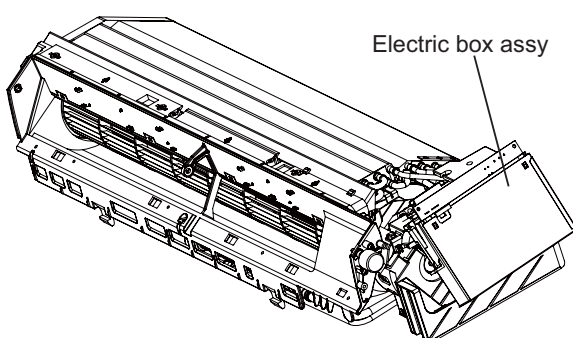
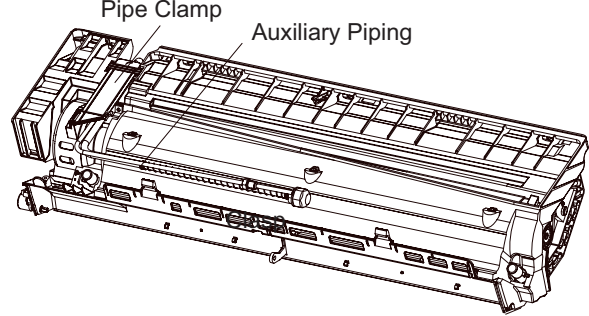
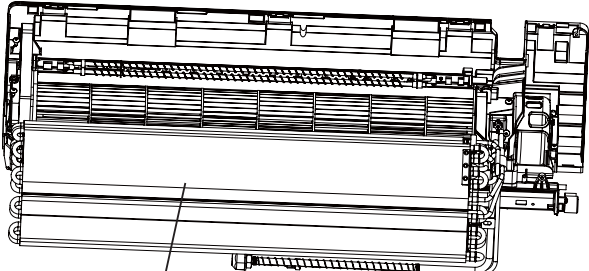
Steps	Procedure
7. Removal of electric box assy	
1	<p>Unplug indoor temp sensor.</p>  <p style="text-align: right;">Indoor temp sensor</p>
2	<p>Remove connection screws of electric box assy and rear case. Release clasps and remove connection screws of earthing wire and evaporator assy. Then remove electric box assy.</p>  <p style="text-align: right;">Electric box cover</p>  <p style="text-align: right;">Electric box assy</p>
8. Removal of evaporator	
1	<p>Turn over the rear case assy and remove connecting pipe clamp. Release clasps between connecting pipe clamp and rear case assy. Then remove connecting pipe clamp.</p>  <p style="text-align: right;">Pipe Clamp Auxiliary Piping</p>
2	<p>Remove connection screws of evaporator assy and motor clamp. Release clasps connecting evaporator assy to rear case. Then remove evaporator assy.</p>  <p style="text-align: right;">Evaporator assy</p>

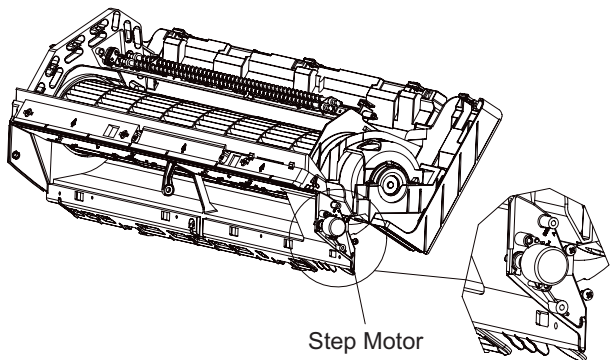
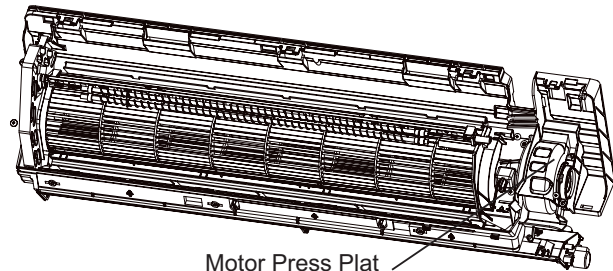
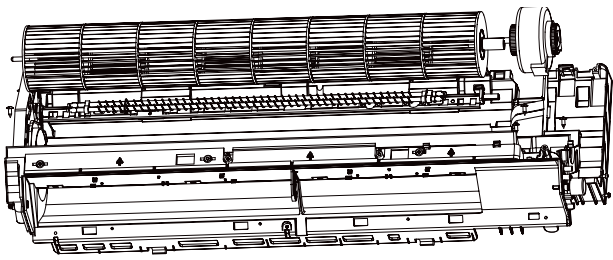
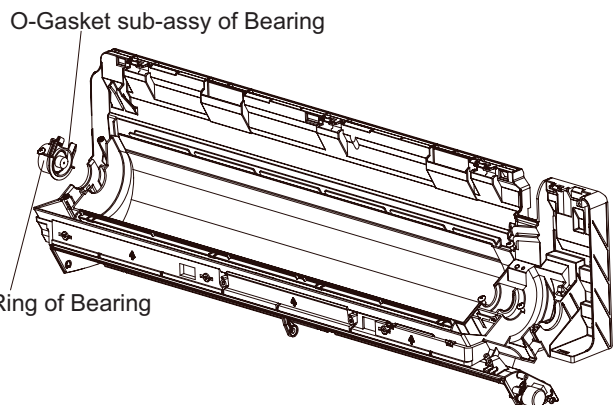
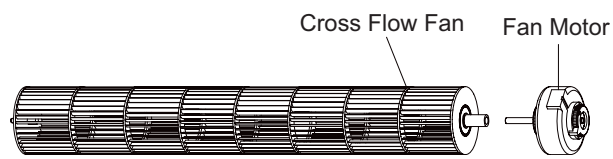
Steps	Procedure
9. Removal of cross flow fan and motor	
1	<p>Remove screws of step motor and then remove the motor.</p>  <p>Step Motor</p>
2	<p>Remove 4 connection screws of motor clamp and rear case. Then remove motor clamp.</p>  <p>Motor Press Plat</p>
3	<p>Remove cross flow fan and motor.</p> 
4	<p>Removal of ring of bearing sub-assy.</p>  <p>O-Gasket sub-assy of Bearing</p> <p>Ring of Bearing</p>
5	<p>Removal of connection screws connecting cross flow fan to motor shaft. Then remove the motor.</p>  <p>Cross Flow Fan</p> <p>Fan Motor</p>

10.2 Removal Procedure of Outdoor Unit

⚠ Warning Be sure to wait for a minimum of 10 minutes after turning off all power supplies before disassembly.

07K

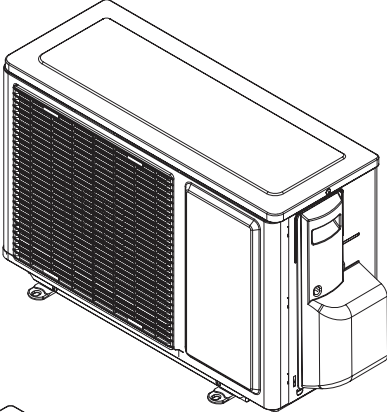
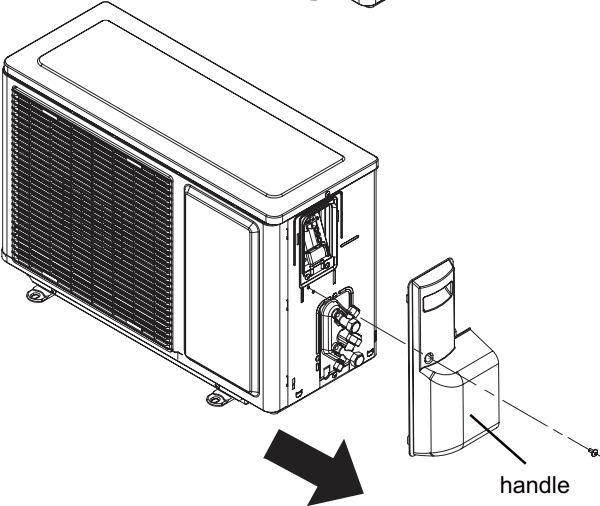
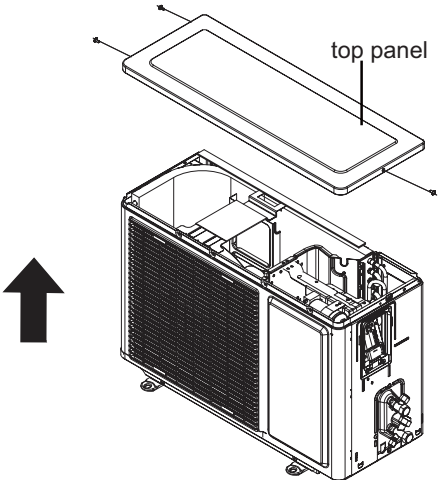
Step	Procedure	
1. Remove big handle		
a	Before disassembly.	
b	Remove the screw fixing the big handle. Remove the big handle.	
2. Remove top panel		
	Remove the 3 screws connecting the top panel with the front panel and the right side panel. Remove the top cover.	

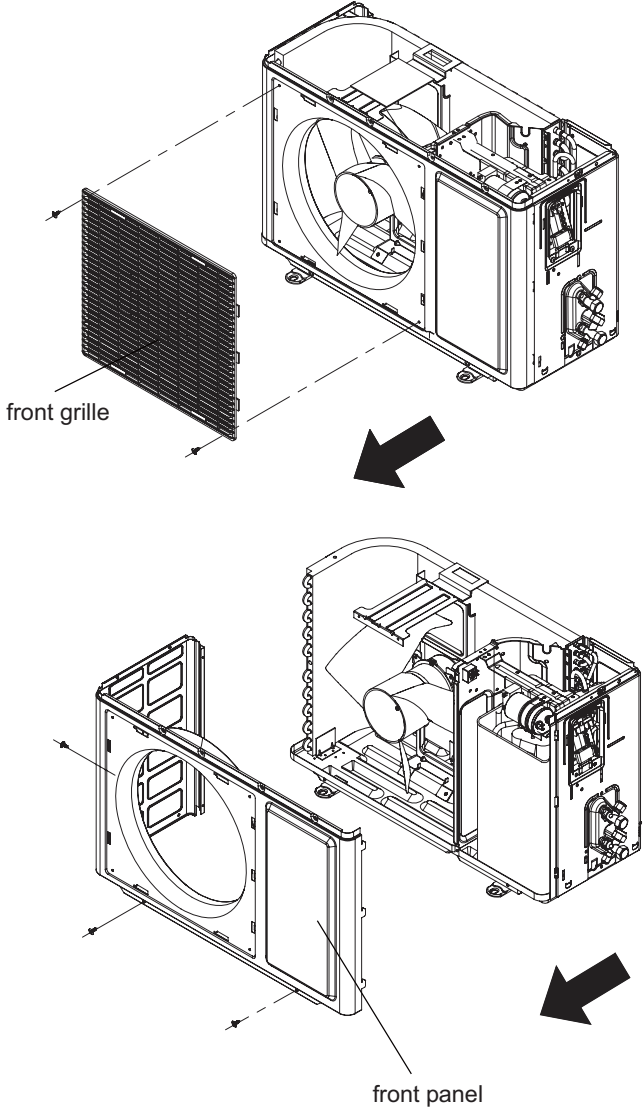
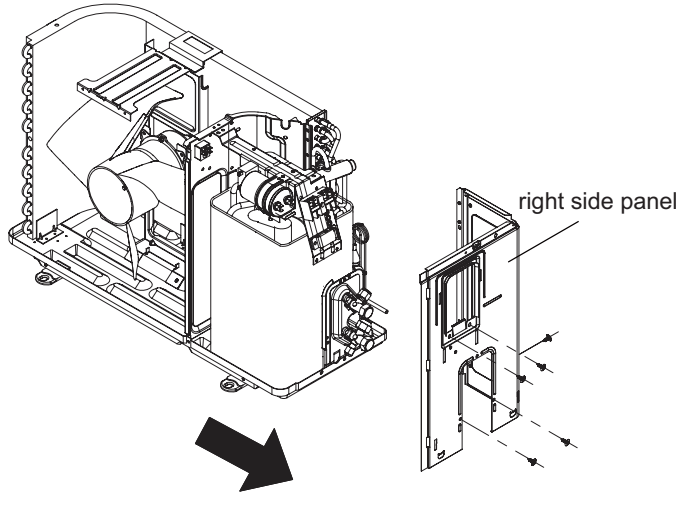
Step	Procedure
<p data-bbox="103 257 561 291">3. Remove front grille and front panel</p> <p data-bbox="119 459 742 526">a Remove the 2 screws connecting the front grille with front panel. Remove front grille.</p> <p data-bbox="119 1086 742 1176">b Remove the 5 screws connecting the front panel with the chassis and the motor support. Remove the front panel.</p>	 <p data-bbox="782 705 893 739">front grille</p> <p data-bbox="1149 1388 1268 1422">front panel</p>
<p data-bbox="103 1456 438 1489">4. Remove right side panel</p>	<p data-bbox="239 1624 750 1713">Remove the 6 screws connecting the right side panel with the chassis, the valve support and the electric box. Remove the right side panel.</p>  <p data-bbox="1332 1646 1492 1680">right side panel</p>

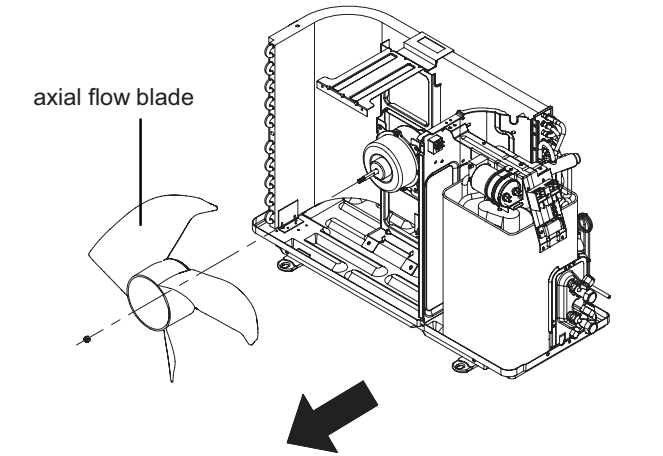
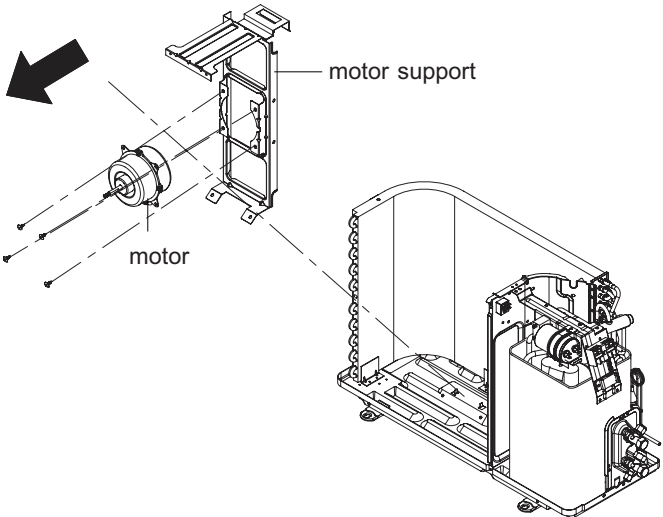
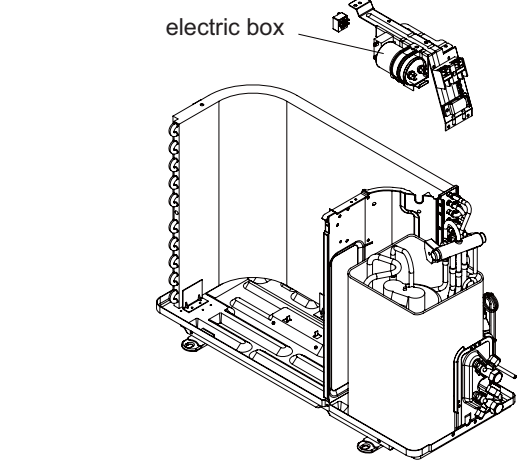
Step	Procedure	
5. Remove axial flow blade and motor		
a	Remove the nut on the blade. Remove the axial flow blade.	
b	Remove the tapping screws fixing the motor; disconnect the leading wire insert of the motor. Remove the motor. Remove the tapping screws fixing the motor support. Lift the motor support to remove it.	
6. Remove electric box		
	Remove screws fixing the electric box subassembly. Loosen the wire bundle; unplug the wiring terminals and lift the electric box to remove it.	

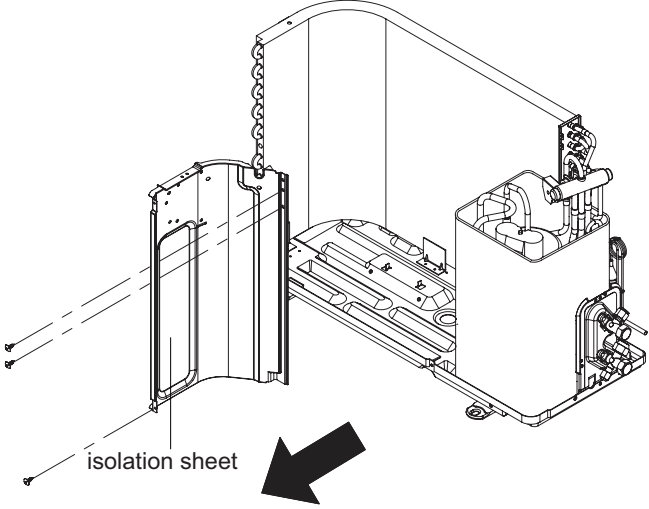
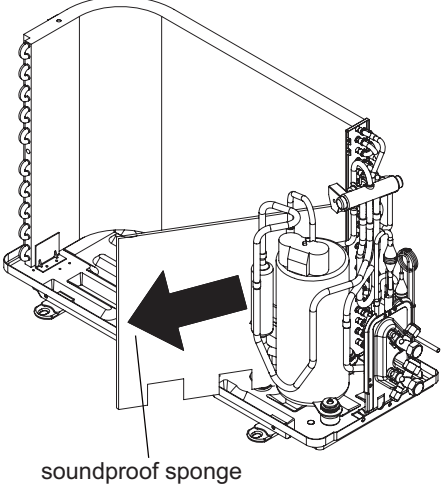
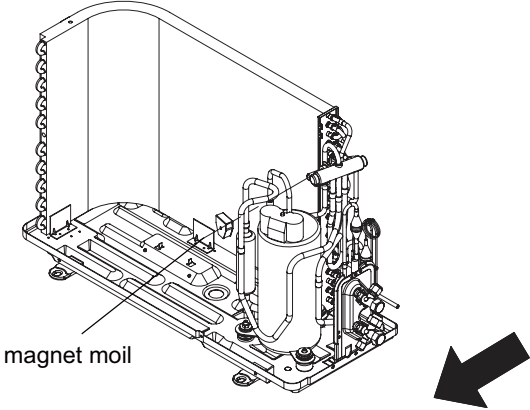
Step	Procedure
<p data-bbox="102 253 427 282">7. Remove isolation sheet</p> <p data-bbox="244 465 738 524">Remove the 3 screws fixing the isolation sheet. Remove the isolation sheet.</p>	 <p>The diagram shows a side view of the compressor unit with the isolation sheet being removed. A label 'isolation sheet' points to the sheet, and a large black arrow indicates the direction of removal.</p>
<p data-bbox="102 866 491 896">8. Remove soundproof sponge</p> <p data-bbox="244 1070 724 1128">Remove the soundproof sponge wrapping the compressor.</p>	 <p>The diagram shows the compressor unit with the soundproof sponge being removed. A label 'soundproof sponge' points to the sponge, and a large black arrow indicates the direction of removal.</p>
<p data-bbox="102 1420 395 1449">9. Remove magnet moil</p> <p data-bbox="244 1635 686 1693">Remove the screw fixing the magnet moil. Remove the coil.</p>	 <p>The diagram shows the compressor unit with the magnet moil being removed. A label 'magnet moil' points to the component, and a large black arrow indicates the direction of removal.</p>

Step	Procedure
10. Remove compressor	
a	<p>Remove the 2 screws fixing the gas valve. Unsolder the welding joint connecting the gas valve and the air-return pipe. Remove the gas valve. (NOTE: when unsoldering, wrap the gas valve with a wet cloth completely to avoid damage to the valve caused by high temperature.)</p> <p>Remove the 2 screws fixing the liquid valve. Unsolder the welding joint connecting the liquid valve and the Y-type pipe. Remove the liquid valve. (NOTE: Discharge the refrigerant completely before unsoldering.)</p>
b	<p>Unsolder welding joint connecting the capillary, the valve and the outlet pipe of condenser to remove the capillary. Do not block the capillary with welding slag during unsoldering. Unsolder the pipes connected to the compressor. Unsolder the welding joint connecting the 4-way valve to remove it.</p>
c	<p>Remove the 3 foot nuts on the compressor. Remove the compressor.</p>

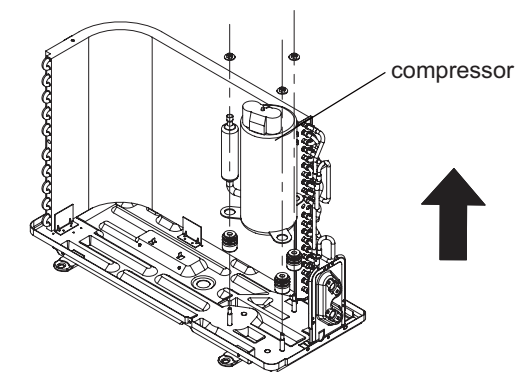
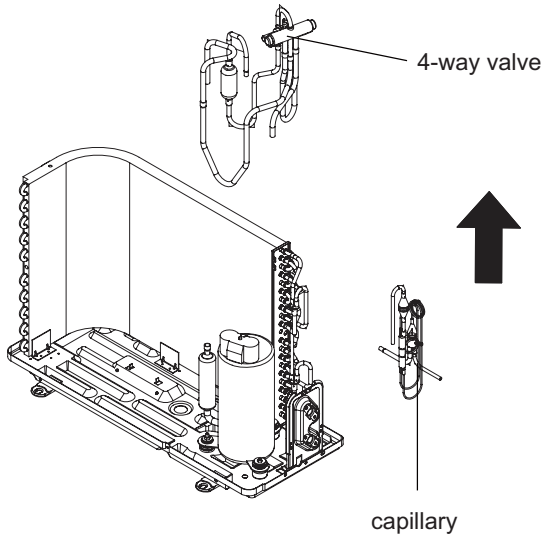
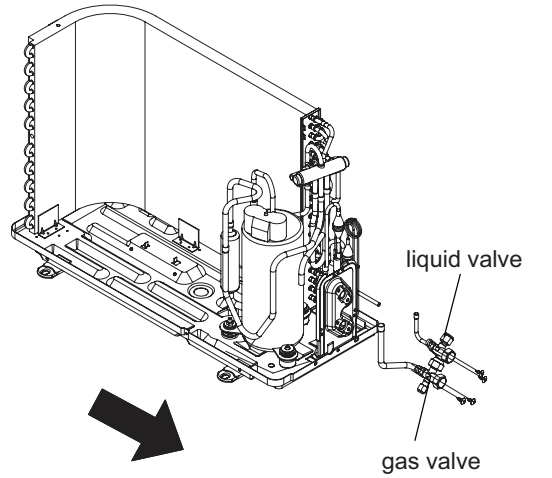

⚠ Warning Be sure to wait for a minimum of 10 minutes after turning off all power supplies before disassembly.

09/12K

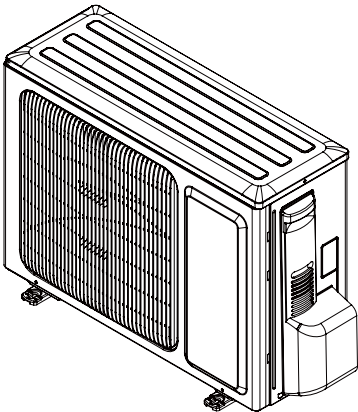
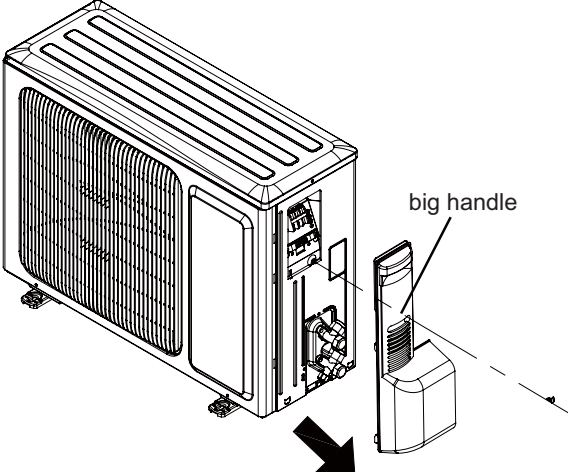
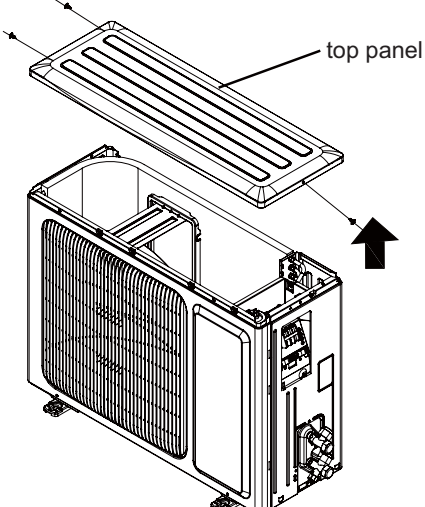
Steps	Procedure	
1. Before disassembly		
2. Remove big handle	Remove the connection screw fixing the big handle and then remove the handle.	
3. Remove top panel	Remove connection screws connecting the top panel with the front panel and the right side plate, and then remove the top panel.	

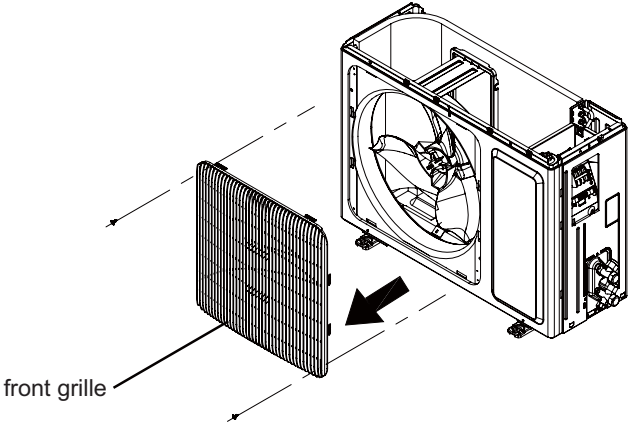
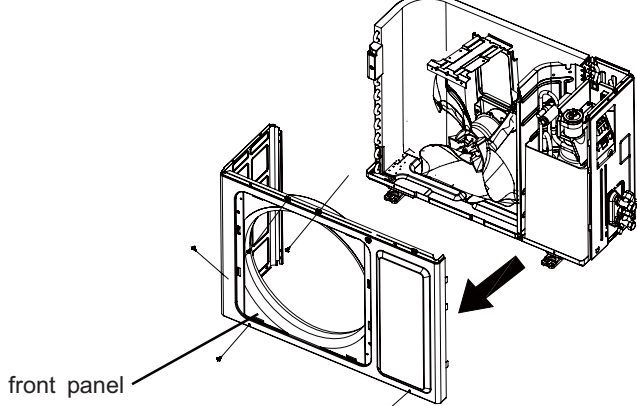
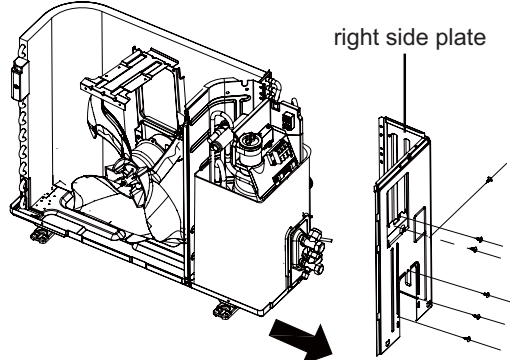
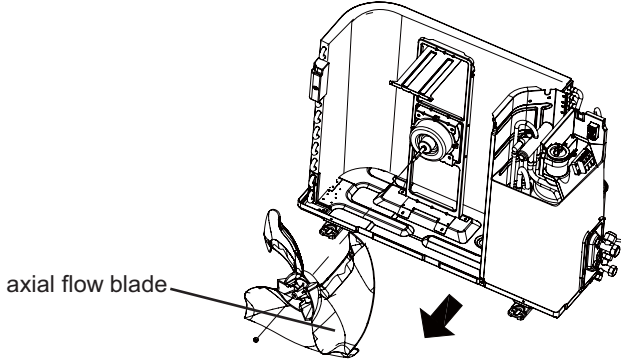
Steps	Procedure
<p>4. Remove front grille</p>	<p>Remove connection screws between the front grille and the front panel. Then remove the front grille.</p>  <p>front grille</p>
<p>5. Remove front panel</p>	<p>Remove connection screws connecting the front panel with the chassis and the motor support, and then remove the front panel.</p>  <p>front panel</p>
<p>6. Remove right side plate</p>	<p>Remove connection screws connecting the right side plate with the chassis, the valve support and the electric box. Then remove the right side plate.</p>  <p>right side plate</p>
<p>7. Remove axial flow blade</p>	<p>Remove the nut on the blade and then remove the axial flow blade.</p>  <p>axial flow blade</p>

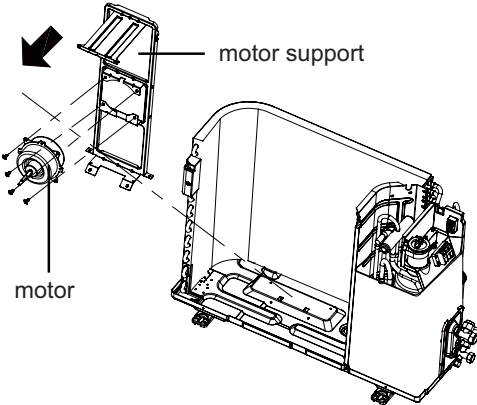
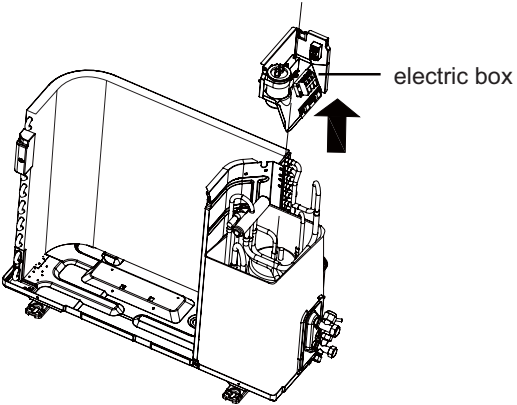
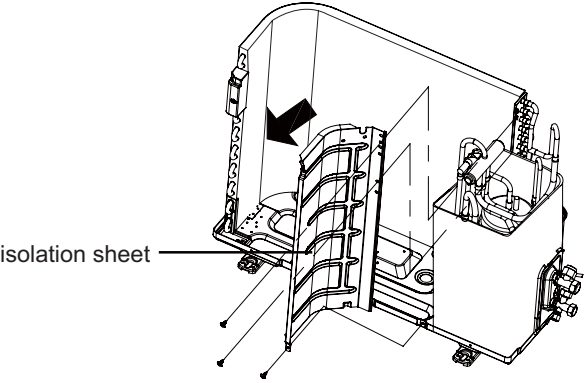
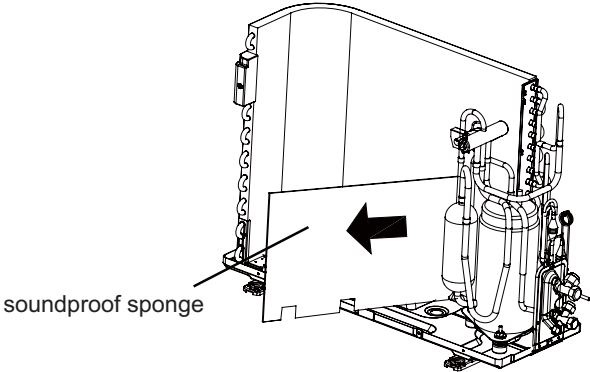
Steps	Procedure
<p>8. Remove motor and motor support</p>	<p>Remove the 4 tapping screws fixing the motor and disconnect the leading wire insert of the motor. Then remove the motor.</p> <p>Remove the 2 tapping screws fixing the motor support and lift the motor support to remove it.</p> 
<p>9. Remove electric box</p>	<p>Remove screws fixing the electric box subassembly; loosen the wire bundle and unplug the wiring terminals. Then lift the electric box to remove it.</p> 
<p>10. Remove isolation sheet</p>	<p>Remove the 3 screws fixing the isolation sheet and then remove the isolation sheet.</p> 
<p>11. Remove soundproof sponge</p>	<p>Remove the soundproof sponge wrapping the compressor.</p> 

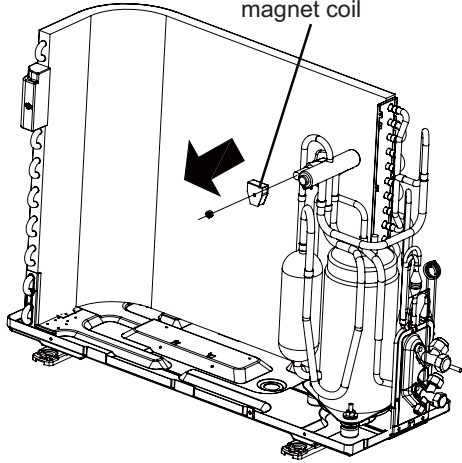
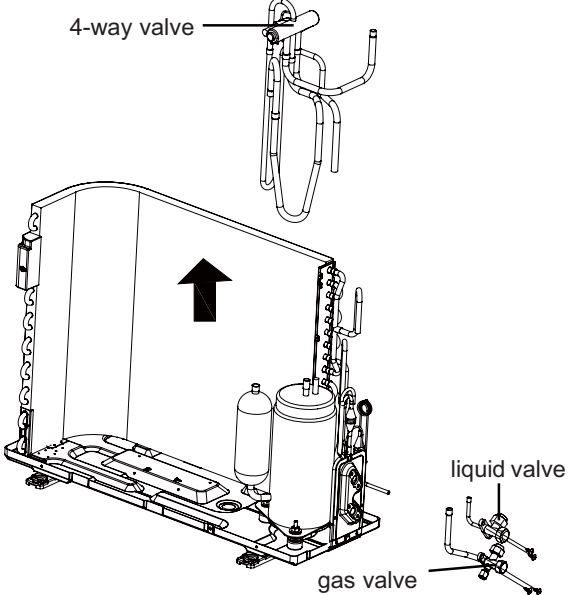
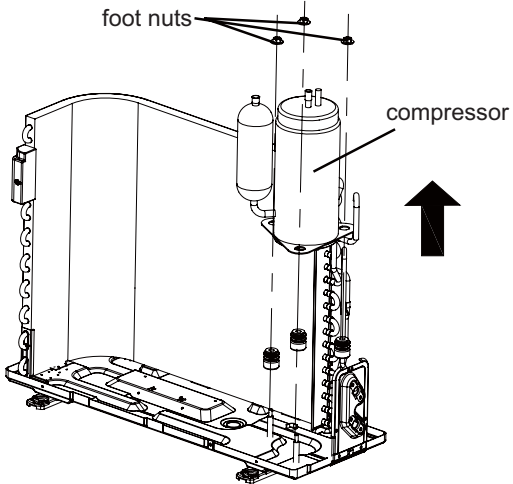
Steps	Procedure
<p>12. Remove magnet coil</p>	<p>Remove the screw fixing the magnet coil and then remove the coil.</p> 
<p>13. Remove valves and 4-way valve subassembly</p>	<p>Unsolder welding joint connecting the capillary, the valve and the outlet pipe of condenser to remove the capillary. Do not block the capillary with welding slag during unsoldering. Remove the 2 screws fixing the gas valve and unsolder the welding point between the gas valve and the air-return pipe to remove the gas valve. (NOTE: Discharge the refrigerant completely before unsoldering; when unsoldering, wrap the gas valve with a wet cloth completely to avoid damage to the valve caused by high temperature). Remove the 2 screws fixing the liquid valve and unsolder the welding joint connecting the liquid valve to the Y-type pipe to remove the liquid valve. Unsolder the welding joint connecting the 4-way valve, the compressor and the condenser to remove the 4-way valve.</p> 
<p>14. Remove compressor</p>	<p>Remove the foot nuts on the compressor and then remove the compressor.</p> 

JF00301359

GREE ELECTRIC APPLIANCES, INC. OF ZHUHAI

Add: West Jinji Rd, Qianshan, Zhuhai, Guangdong, China, 519070
Tel: (+86-756) 8522218 Fax: (+86-756) 8669426
E-mail: gree@gree.com.cn www.gree.com

For continuous improvement in the products, Gree reserves the right to modify the product specification and appearance in this manual without notice and without incurring any obligations.