



Owner's Manual

Original Instructions

Dehumidifier

Thank you for choosing our product.

Please read this Owner's Manual carefully before operation and retain it for future reference.

If you have lost the Owner's Manual, please contact the local agent or visit www.gree.com or send an email to global@gree.com.cn for the electronic version.

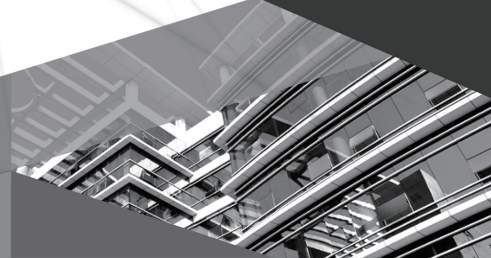

GDN16BE-K5EBA1A
GDN20BE-K5EBA1A

Content

Operation Notices

- The Refrigerant.....1
- Safety Precautions.....2
- Operation Area.....3
- Parts Name.....4

Operation Instructions

- Operation Method.....5
- Drainage Method7

Maintenance

- Clean and Maintenance.....9

Malfunction

- Troubleshooting.....11
- Malfunction Codes13
- Electric schematic diagram14
- Specialist's Manual15

Note:

Graphics in this manual are only for reference. Please refer to actual products for specific details.

This appliance is not intended for use by persons (including children) with reduced physical, sensory or mental capabilities, or lack of experience and knowledge, unless they have been given supervision or instruction concerning use of the appliance by a person responsible for their safety. Children should be supervised to ensure that they do not play with the appliance.



This marking indicates that this product should not be disposed with other household wastes throughout the EU. To prevent possible harm to the environment or human health from uncontrolled waste disposal, recycle it responsibly to promote the sustainable reuse of material resources. To return your used device, please use the return and collection systems or contact the retailer where the product was purchased. They can take this product for environmental safe recycling.

Explanation of Symbols



DANGER

Indicates a hazardous situation that, if not avoided, will result in death or serious injury.



WARNING

Indicates a hazardous situation that, if not avoided, could result in death or serious injury.



CAUTION

Indicates a hazardous situation that, if not avoided, may result in minor or moderate injury.

NOTICE

Indicates important but not hazard-related information, used to indicate risk of property damage.



Indicates a hazard that would be assigned a signal word **WARNING** or **CAUTION**.

Exception Clauses

Manufacturer will bear no responsibilities when personal injury or property loss is caused by the following reasons.

1. Damage the product due to improper use or misuse of the product;
2. Alter, change, maintain or use the product with other equipment without abiding by the instruction manual of manufacturer;
3. After verification, the defect of product is directly caused by corrosive gas;
4. After verification, defects are due to improper operation during transportation of product;
5. Operate, repair, maintain the unit without abiding by instruction manual or related regulations;
6. After verification, the problem or dispute is caused by the quality specification or performance of parts and components that produced by other manufacturers;
7. The damage is caused by natural calamities, bad using environment or force majeure.

If it needs to install, move or maintain the appliance, please contact dealer or local service center to conduct it at first. The appliance must be installed, moved or maintained by appointed unit. Otherwise, it may cause serious damage or personal injury or death.

When refrigerant leaks or requires discharge during installation, maintenance, or disassembly, it should be handled by certified professionals or otherwise in compliance with local laws and regulations.



Appliance filled with flammable gas R290.



Before install and use the appliance, read the owner's manual first.



Before install the appliance, read the installation manual first.



Before repair the appliance, read the service manual first.

The Refrigerant

- To realize the function of the unit, a special refrigerant circulates in the system. The used refrigerant is the fluoride R290, which is specially cleaned. The refrigerant is flammable and inodorous. Furthermore, it can lead to explosion under certain conditions.
- Compared to common refrigerants, R290 is a nonpolluting refrigerant with no harm to the ozone layer. The influence upon the greenhouse effect is also lower. R290 has got very good thermodynamic features which lead to a really high energy efficiency. The units therefore need a less filling.
- Please refer to the nameplate for the charging quantity of R290.

WARNING :

- Appliance filled with flammable gas R290.
- Appliance shall be installed, operated and stored in a room with a floor area larger than 4 m².
- The appliance shall be stored in a room without continuously operating ignition sources . (for example: open flames, an operating gas appliance or an operating electric heater.)
- The appliance shall be stored in a well-ventilated area where the room size corresponds to the room area as specified for operation.
- The appliance shall be stored so as to prevent mechanical damage from occurring.
- Keep any required ventilation openings clear of obstruction.
- Do not pierce or burn.
- Be aware that refrigerants may not contain an odour.
- Do not use means to accelerate the defrosting process or to clean, other than those recommended by the manufacturer.
- Servicing shall be performed only as recommended by the manufacturer.
- Should repair be necessary, contact your nearest authorized Service Centre. Any repairs carried out by unqualified personnel may be dangerous.
- Compliance with national gas regulations shall be observed.
- Read specialist's manual.

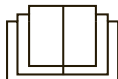

Safety Precautions

- This appliance can be used by children aged from 8 years and above and persons with reduced physical, sensory or mental capabilities or lack of experience and knowledge if they have been given supervision or instruction concerning use of the appliance in a safe way and understand the hazards involved.
- Children shall not play with the appliance.
- Cleaning and user maintenance shall not be made by children without supervision.
- Before operation, please check the power cord if it complies with the requirement indicated on the nameplate.
- Before cleaning, please turn it off and unplug the dehumidifier.
- Make sure the power cord is not pressed by any hard object.
- Do not remove the power plug or move unit by pulling the power cord.
- Do not use any heating application near the dehumidifier.
- Do not remove the power plug in wet hands.
- Please use grounded power cord and make sure it's well connected and not damaged.
- Children and disabled people are not allowed to use the dehumidifier without supervision.
- Keep children from playing or climbing on the dehumidifier.
- Do not place the dehumidifier under dripping objects.
- Memory function is included in this dehumidifier. When nobody is taking care of the unit, please turn it off and remove the power plug or disconnect power.
- Do not repair or disassemble the unit by yourself.
- If the supply cord is damaged, it must be replaced by the manufacturer, its service agent or similarly qualified persons in order to avoid a hazard.
- If abnormal condition occurs (e.g. burned smell), please disconnect power at once and then contact local dealer.
- Dehumidifier can not be disposed of everywhere. If you want to get rid of this dehumidifier, please check with local handling disposal or information service center about what to do.
- Do not use an extension cord.
- The appliance shall be installed in accordance with national wiring regulations.
- Prohibit operating the unit in the bathroom or laundry room.

Operation Area

- This dehumidifier is intended for indoor residential applications only. It should not be used for commercial or industrial applications.
- Place the dehumidifier on a smooth and level floor.
- A dehumidifier operating indoors will have no effect in drying an adjacent enclosed area, such as a closet.
- Place the dehumidifier in an area where the temperature will not be below 5°C or above 32°C.
- Allow at least 30 cm of air space on all sides of the unit.
- Close all doors, windows and other outside openings of the room to improve the working effect.
- Please keep the air inlet/outlet clean and not blocked.
- Do not use a dehumidifier in a bathroom.
- Avoid direct sunlight.

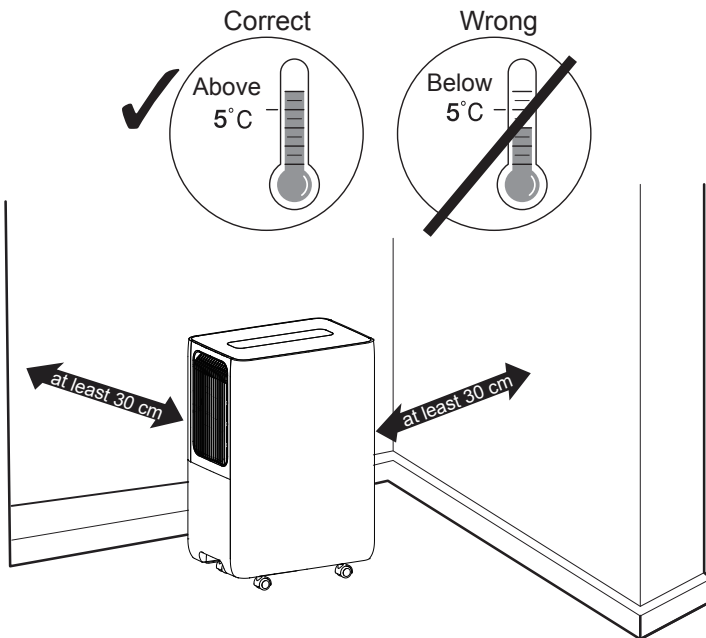

Note:

The dehumidifier has rollers to aid placement. Do not attempt to roll the dehumidifier on carpet or over objects. Otherwise, water may spill out from the bucket or the dehumidifier may get stuck by the objects.

Parts Name

Front Side

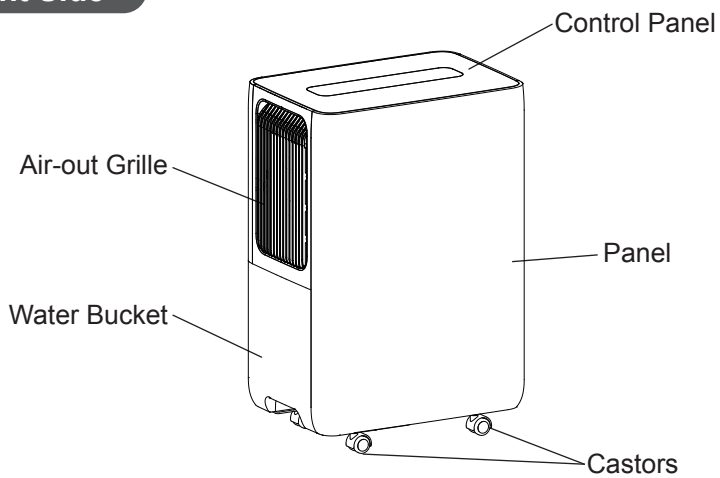

Back Side

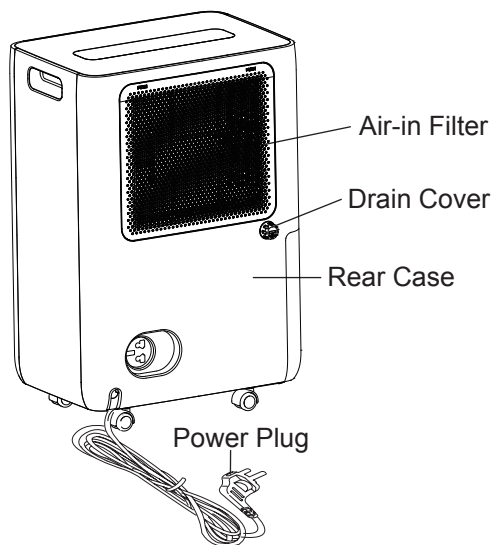

Operation Method

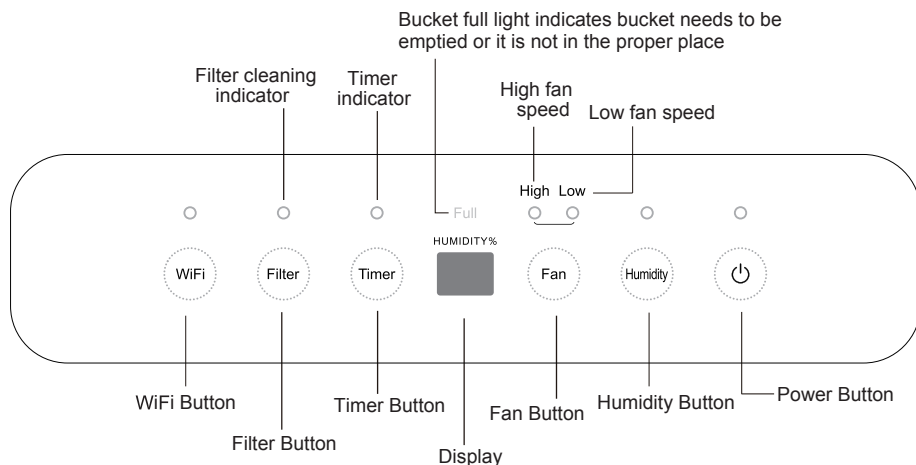

Notes:

- Water bucket must be correctly installed for the dehumidifier to operate.
- Do not remove the bucket while unit is in operation.
- If you want to use drain hose to drain water away, please install the hose according to section "Drainage method".
- Each time pressing the effective button on the control panel will give out a "beep" sound.

Basic Functions of the Buttons

- 1 Power Button 

Press this button to turn on/off dehumidifier.

- 2 Humidity Button 

As for setting the humidity, after each pressing of humidity button, the set humidity will increase 5% in the range of 30%-80% circularly; Hold the humidity button can adjust the humidity quickly.

3 Fan Button

Fan

Press this button can freely switch from high fan speed to low fan speed. When you need fast dehumidification, select high fan speed; when you need the unit to work quietly, select low fan speed.

4 Timer Button

Timer

Press this button can make the unit work on designated time. The timer function takes hour as unit, and 0-24h can be circularly set. Duration of timer can be transitorily displayed on the panel.

5 Filter Button

Filter

Press this button to turn off Filter Cleaning Indicator. (When dehumidifier has been operating for 250 hours, Filter Cleaning Indicator will be lit up to remind user of filter cleaning.)

6 WiFi Button

WiFi

Whether the unit is turned on or turned off, press WiFi button can turn on or turn off WiFi function;

Whether the unit or WiFi is turned on or turned off, hold WiFi button for 5s can reset WiFi. At the same time, WiFi function will be turned on.

7 Display

The humidity display window is defaulted to display current environment humidity. If press humidity button to adjust the humidity, it will display the set humidity. 5s later, it will turn back to display the ambient humidity.

Other Instructions

1. Alarm Warning

If bucket is full or not locked into place for over 3min, buzzer will beep for 10s to remind you to empty bucket or put it back into the correct place.

2. Auto Stop

When bucket is full, removed or not placed correctly or the humidity is 5% lower than the set humidity, unit will automatically stop.

3. Memory Function

If power is lost, all of the control settings are remembered. So when power is restored, the unit will start back up in the settings it was in when power was lost.

4. Bucket full light

This indicates that bucket is full or removed or not placed correctly.

5. Clean the Filter On indicator light

When dehumidifier has been operating for 250 hours, Filter Cleaning Indicator will be lit up to remind user of filter cleaning.

Drainage Method

Option 1 Emptying Manually

Notes:

- Do not remove the bucket when unit is in operation or has just stopped. Otherwise it may cause some water to drip on the floor.
 - Do not use the hose if using water bucket to collect water. When the hose is connected, water will be drained out through it instead of into the bucket.
1. Hold the handles on bottom side of the water bucket and pull it out following the arrow direction. (Attention: Pull out the bucket carefully in case the water may spill out from the bucket and onto the floor.)

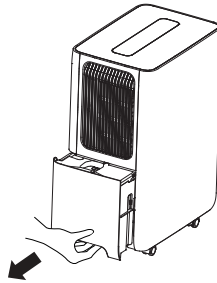

2. Empty the bucket by grasping the handle on the bottom of bucket with one hand and grasping the bottom of bucket with the other hand.

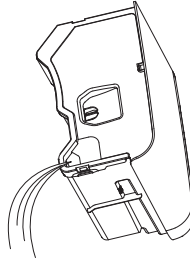

3. Replace bucket in the dehumidifier according to the arrow direction.

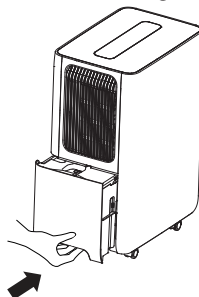

Option 2 Gravity Drain Hose

1. Hose is not provided, so user shall prepare it in advance.
[Size: The hose should have an inner diameter of 14mm]
2. Unscrew the drain cover, and pull out the rubber plug from the unit as instructed.
3. Take out the adaptor and connect it firmly to the continuous drainage port.
4. Thread the drain hose onto the adaptor and make sure it's securely locked.

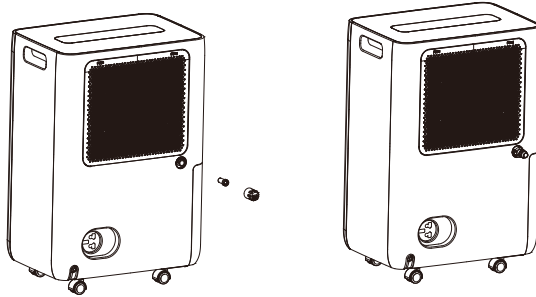

5. Replace the bucket. Make sure the drain hose goes through the bucket's drain hole and is placed downward. Lead the hose to the floor drain and then cover the hole with a lid. Note that drain hose should not be pressed, otherwise water can not be drained out.

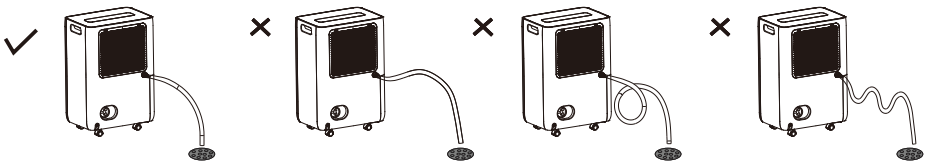

Note: When you want to take off the drain hose, prepare a receptacle to collect water from the nozzle.

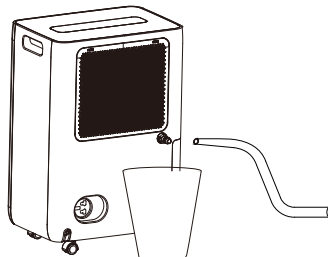

Clean and Maintenance

Warning:

- Before cleaning, turn off the dehumidifier and disconnect power. Otherwise it may lead to electric shock.
- Do not wash the dehumidifier with water, or it may lead to electric shock.
- Do not use volatile liquid(such as thinner or gasoline) to clean dehumidifier. Otherwise it will damage unit's appearance.

1. Grille and Case

To clean the case:

When there is dust on the case, use soft towel to dust it off; When the case is very dirty(greasy), use mild detergent to clean it.

To clean the grille:Use a dust catcher or brush.

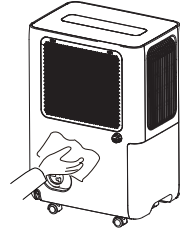

2. Filter

The filter should be checked and cleaned at least every 250 hours of operation or more often if necessary.

To remove: Press the "PUSH" above the filter with two hands simultaneously, then the filter can be removed.

To clean: Clean the filter in warm, soapy water. Rinse it and let the filter dry before replacing it.

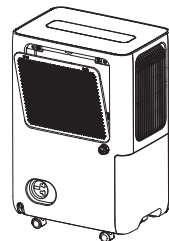
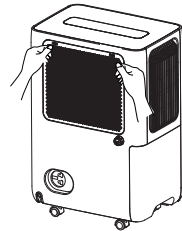

Warning:

- Do not operate the dehumidifier without a filter. Otherwise the evaporator will catch dust and affect unit's performance.
- Do not dry the filter with fire or electric hair dryer. Otherwise the filter may be unshaped or caught on fire.
- Don't use dust catcher or brush to clean the filter. Otherwise the filter may be destroyed

Check Before Use-season

- Check whether air outlet is blocked.
- Check whether power plug and power socket are in good condition.
- Check whether air filter is clean.
- Check whether drain hose is damaged.

Care After Use-season

- Disconnect power.
- Clean air filter and case.
- Clean dust and obstacle of the dehumidifier.
- Empty the water bucket.

Long-time Storage

If you won't use the dehumidifier for a long time, we suggest that you follow the steps below in order to maintain the unit in good condition.

- Make sure the bucket is clear of water and drain hose is removed.
- Clean the unit and wrap it well to prevent the gathering of dust.

Troubleshooting

- Not all the following problems are malfunctions.

Problem	Possible Causes
Dehumidifier is not operating. Controls can not be set.	<ul style="list-style-type: none"> ● Unit is operating in an area where temperature is higher than 32°C or lower than 5°C. ● Bucket is full.
Noise suddenly rises during operation.	<ul style="list-style-type: none"> ● Noise will rise if compressor has just started. ● Power supply problem. ● Unit is placed on uneven floor.
Humidity does not drop.	<ul style="list-style-type: none"> ● Area to be dehumidified is too large. The capacity of your dehumidifier may not be adequate. ● Doors are open. ● There might be some device producing vapor in the room.
Little or no effect in dehumidifying	<ul style="list-style-type: none"> ● Room temperature is too low. ● Humidity level may be improperly set. ● If unit is operating in a room where temperature is from 5 to 15 °C, it will start to defrost automatically. Compressor will stop for a brief period of time(fan will operate in high fan speed). When unit finishes defrosting, it will be back to normal operation.
When first operated, the air emitted has musty-odor.	<ul style="list-style-type: none"> ● Due to temperature rising of heat exchanger, the air may have some strange smell at the beginning.
Unit has noise.	<ul style="list-style-type: none"> ● There might be some noise if unit is operating on wooden floor.
Swooshing sound is heard.	<ul style="list-style-type: none"> ● Normal. This is the sound of the flow of refrigerant.

- Problem of Water Leakage.

Problem	Possible Causes	Solution
When using drain hose, there is water in the bucket.	<ul style="list-style-type: none"> ● Examine the drainage joint. 	<ul style="list-style-type: none"> ● Connect the drainage joint well.
	<ul style="list-style-type: none"> ● Drain hose is not correctly installed. 	<ul style="list-style-type: none"> ● Clear the obstacle from the drain hose. ● Remove the drain hose and replace it. Be sure that the hose is correctly installed.

● Dehumidifier does not start.

Problem	Possible Causes	Solution
Power indicator is not lit when power is connected.	<ul style="list-style-type: none"> ● Power is not supplied for the dehumidifier or the power plug is not well inserted. 	<ul style="list-style-type: none"> ● Check if power is lost. If yes, wait for the power to restore. ● If not, check whether the power circuit or power socket has been damaged. ● Check whether power plug is loosen. ● Check whether power cord is damaged.
	<ul style="list-style-type: none"> ● Fuse is blown. 	<ul style="list-style-type: none"> ● Replace the main board.
Bucket full indicator is lit up.	<ul style="list-style-type: none"> ● Bucket is not properly placed. ● Water is full in the bucket. ● Bucket has been removed. 	<ul style="list-style-type: none"> ● Empty the bucket and replace it.
Unit can function normally but it can not start up.	<ul style="list-style-type: none"> ● Humidity is set too high. 	<ul style="list-style-type: none"> ● If you want the air drier, press humidity button to lower the figure for unit to dehumidify continuously.

● Dehumidifier does not dry air as intended.

Bad dehumidifying performance	<ul style="list-style-type: none"> ● Check whether there is any obstacle around the unit. 	<ul style="list-style-type: none"> ● Make sure there is no curtain, shutter or furniture that blocks the dehumidifier.
	<ul style="list-style-type: none"> ● Air filter is dusty and blocked. 	<ul style="list-style-type: none"> ● Clean the filter.
	<ul style="list-style-type: none"> ● Doors and windows are left open. 	<ul style="list-style-type: none"> ● Make sure all doors and windows and other opening to the outside have been closed.
	<ul style="list-style-type: none"> ● Room temperature is too low. 	<ul style="list-style-type: none"> ● Warm temperature is good for dehumidification. Low temperature will reduce unit's working effect. This unit should be working in a place where temperature is above 5°C.

Malfunction Codes

● Unit's Malfunction Codes

No.	Malfunction Name	Display Code	Unit's Condition	Possible Causes
		Display Window		
1	Ambient Temperature Sensor Malfunction	F1	Compressor and fan motor stop.	● Ambient temperature sensor is loosen or is poorly connected with the terminal of display board.
				● Some element of display board may have been put upside down and cause short circuit.
				● Ambient temperature sensor is damaged.
				● Display board is damaged.
2	Tube Temperature Sensor Malfunction	F2	Compressor and fan motor stop. This button is invalid.	● Temperature sensor on the evaporator is loosen or is poorly connected with the terminal of display board.
				● Some element of display board may have been put upside down and cause short circuit.
				● Temperature sensor on the evaporator is damaged.
				● Display board is damaged.
3	Humidity Sensor Malfunction	L1		<ul style="list-style-type: none"> ● Humidity sensor is short-circuited. ● Humidity sensor is damaged. ● Display board is damaged.

No.	Malfunction Name	Display Code	Unit's Condition	Possible Causes
		Display Window		
4	Freon-lacking protection	F0	Compressor stops operation. 30s later, the fan will also stop operation.	<ul style="list-style-type: none"> Refrigerant is leaking. System is blocked.
5	High-temperature overload protection	H3		<ul style="list-style-type: none"> Ambient operation condition is bad. The evaporator and condenser are blocked with filth. The system is abnormal.

Electric schematic diagram

The Electric schematic diagram are subject to change without notice. Please refer to which one on the unit.

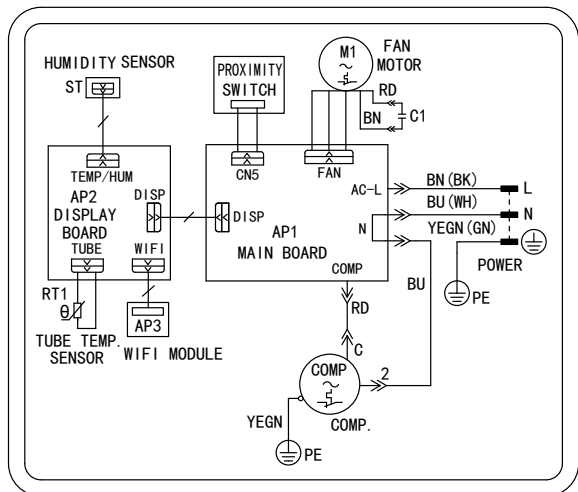

Aptitude requirement for maintenance man(repairs should be done only be specialists).

a. All the work men who are engaging in the refrigeration system should bear the valid certification awarded by the authoritative organization and the qualification for dealing with the refrigeration system recognized by this industry.

b. It can only be repaired by the method suggested by the equipment's manufacturer. If it needs other technician to maintain and repair the appliance, they should be supervised by the person who bears the qualification for using the flammable refrigerant.

Safety preparation work before installation

The safety must be inspected before maintaining the appliances with the flammable refrigerant for reducing the flammable hazard to the lowest.

Work shall be undertaken under a controlled procedure so as to minimise the risk of a flammable gas or vapour being present while the work is being performed.

Detection of flammable refrigerants

Under no circumstances shall potential sources of ignition be used in the searching for or detection of refrigerant leaks. A halide torch (or any other detector using a naked flame) shall not be used.

Environment checking

- All maintenance staff and others working in the local area shall be instructed on the nature of work being carried out. Work in confined spaces shall be avoided. The area around the workspace shall be sectioned off. Ensure that the conditions within the area have been made safe by control of flammable material.
- The area shall be checked with an appropriate refrigerant detector prior to and during work, to ensure the technician is aware of potentially toxic or flammable atmospheres. Ensure that the leak detection equipment being used is suitable for use with all applicable refrigerants, i.e. non-sparking, adequately sealed or intrinsically safe.
- No person carrying out work in relation to a refrigeration system which involves exposing any pipe work shall use any sources of ignition in such a manner that it may lead to the risk of fire or explosion. All possible ignition sources, including cigarette smoking, should be kept sufficiently far away from the site of installation, repairing, removing and disposal, during which refrigerant can possibly be released to the surrounding space. Prior to work taking place, the area around the equipment is to be surveyed to make sure that there are no flammable hazards or ignition risks. "No Smoking" signs shall be displayed.
- If any hot work is to be conducted on the refrigeration equipment or any associated parts, appropriate fire extinguishing equipment shall be available to hand. Have a dry powder or CO₂ fire extinguisher adjacent to the charging area.
- Ensure that the area is in the open or that it is adequately ventilated before breaking into the system or conducting any hot work. A degree of ventilation shall continue during the period that the work is carried out. The ventilation should safely disperse any released refrigerant and preferably expel it externally into the atmosphere.

Specialist's Manual

Refrigeration equipment Checking

Where electrical components are being changed, they shall be fit for the purpose and to the correct specification. At all times the manufacturer's maintenance and service guidelines shall be followed. If in doubt, consult the manufacturer's technical department for assistance.

The following checks shall be applied to installations using flammable refrigerants:

- The actual refrigerant charge is in accordance with the room size within which the refrigerant containing parts are installed;
- The ventilation machinery and outlets are operating adequately and are not obstructed;
- If an indirect refrigerating circuit is being used, the secondary circuit shall be checked for the presence of refrigerant;
- Marking to the equipment continues to be visible and legible. Markings and signs that are illegible shall be corrected;
- Refrigeration pipe or components are installed in a position where they are unlikely to be exposed to any substance which may corrode refrigerant containing components, unless the components are constructed of materials which are inherently resistant to being corroded or are suitably protected against being so corroded.

Electrical devices checking

Repair and maintenance to electrical components shall include initial safety checks and component inspection procedures. If a fault exists that could compromise safety, then no electrical supply shall be connected to the circuit until it is satisfactorily dealt with. If the fault cannot be corrected immediately but it is necessary to continue operation, an adequate temporary solution shall be used. This shall be reported to the owner of the equipment so all parties are advised.

Initial safety checks shall include:

- That capacitors are discharged: this shall be done in a safe manner to avoid possibility of sparking;
- That no live electrical components and wiring are exposed while charging, recovering or purging the system;
- That there is continuity of earth bonding.

Repairs to sealed components

During repairs to sealed components, all electrical supplies shall be disconnected from the equipment being worked upon prior to any removal of sealed covers, etc. If it is absolutely necessary to have an electrical supply to equipment during servicing, then a permanently operating form of leak detection shall be located at the most critical point to warn of a potentially hazardous situation.

Particular attention shall be paid to the following to ensure that by working on electrical components, the casing is not altered in such a way that the level of protection is affected. This shall include damage to cables, excessive number of connections, terminals not made to original specification, damage to seals, incorrect fitting of glands, etc.

Specialist's Manual

- Ensure that the apparatus is mounted securely.
- Ensure that seals or sealing materials have not degraded to the point that they no longer serve the purpose of preventing the ingress of flammable atmospheres. Replacement parts shall be in accordance with the manufacturer's specifications.

NOTE : The use of silicon sealant can inhibit the effectiveness of some types of leak detection equipment. Intrinsically safe components do not have to be isolated prior to working on them.

Cabling

Check that cabling will not be subject to wear, corrosion, excessive pressure, vibration, sharp edges or any other adverse environmental effects. The check shall also take into account the effects of aging or continual vibration from sources such as compressors or fans.

Leak detection methods

The following leak detection methods are deemed acceptable for all refrigerant systems.

Electronic leak detectors may be used to detect refrigerant leaks but, in the case of flammable refrigerants, the sensitivity may not be adequate, or may need re-calibration. (Detection equipment shall be calibrated in a refrigerant-free area.) Ensure that the detector is not a potential source of ignition and is suitable for the refrigerant used. Leak detection equipment shall be set at a percentage of the LFL of the refrigerant and shall be calibrated to the refrigerant employed, and the appropriate percentage of gas (25 % maximum) is confirmed.

Leak detection fluids are suitable for use with most refrigerants but the use of detergents containing chlorine shall be avoided as the chlorine may react with the refrigerant and corrode the copper pipe-work.

If a leak is suspected, all naked flames shall be removed/extinguished.

If a leakage of refrigerant is found which requires brazing, all of the refrigerant shall be recovered from the system, or isolated (by means of shut off valves) in a part of the system remote from the leak. For appliances containing flammable refrigerants, oxygen free nitrogen (OFN) shall then be purged through the system both before and during the brazing process

Removal and evacuation

When breaking into the refrigerant circuit to make repairs – or for any other purpose – conventional procedures shall be used. However, for flammable refrigerants it is important that best practice is followed since flammability is a consideration. The following procedure shall be adhered to:

- remove refrigerant;
- purge the circuit with inert gas;
- evacuate;
- purge again with inert gas;
- open the circuit by cutting or brazing.

Specialist's Manual

The refrigerant charge shall be recovered into the correct recovery cylinders. For appliances containing flammable refrigerants, the system shall be “flushed” with OFN to render the unit safe. This process may need to be repeated several times. Compressed air or oxygen shall not be used for purging refrigerant systems.

For appliances containing flammable refrigerants, flushing shall be achieved by breaking the vacuum in the system with OFN and continuing to fill until the working pressure is achieved, then venting to atmosphere, and finally pulling down to a vacuum. This process shall be repeated until no refrigerant is within the system.

When the final OFN charge is used, the system shall be vented down to atmospheric pressure to enable work to take place. This operation is absolutely vital if brazing operations on the pipe-work are to take place.

Ensure that the outlet for the vacuum pump is not close to any ignition sources and that ventilation is available.

Charging procedures

In addition to conventional charging procedures, the following requirements shall be followed.

- Ensure that contamination of different refrigerants does not occur when using charging equipment. Hoses or lines shall be as short as possible to minimise the amount of refrigerant contained in them.
- Cylinders shall be kept upright.
- Ensure that the refrigeration system is earthed prior to charging the system with refrigerant.
- Label the system when charging is complete (if not already).
- Extreme care shall be taken not to overfill the refrigeration system.

Prior to recharging the system, it shall be pressure-tested with the appropriate purging gas. The system shall be leak-tested on completion of charging but prior to commissioning. A follow up leak test shall be carried out prior to leaving the site.

Decommissioning

Before carrying out this procedure, it is essential that the technician is completely familiar with the equipment and all its detail. It is recommended good practice that all refrigerants are recovered safely. Prior to the task being carried out, an oil and refrigerant sample shall be taken in case analysis is required prior to re-use of reclaimed refrigerant. It is essential that electrical power is available before the task is commenced.

- a) Become familiar with the equipment and its operation.
- b) Isolate system electrically.
- c) Before attempting the procedure, ensure that:
 - mechanical handling equipment is available, if required, for handling refrigerant cylinders;
 - all personal protective equipment is available and being used correctly;
 - the recovery process is supervised at all times by a competent person;
 - recovery equipment and cylinders conform to the appropriate standards.
- d) Pump down refrigerant system, if possible.
- e) If a vacuum is not possible, make a manifold so that refrigerant can be removed from various parts of the system.

Specialist's Manual

- f) Make sure that cylinder is situated on the scales before recovery takes place.
- g) Start the recovery machine and operate in accordance with manufacturer's instructions.
- h) Do not overfill cylinders. (No more than 80 % volume liquid charge).
 - i) Do not exceed the maximum working pressure of the cylinder, even temporarily.
 - j) When the cylinders have been filled correctly and the process completed, make sure that the cylinders and the equipment are removed from site promptly and all isolation valves on the equipment are closed off.
- k) Recovered refrigerant shall not be charged into another refrigeration system unless it has been cleaned and checked.

Labelling

Equipment shall be labelled stating that it has been de-commissioned and emptied of refrigerant. The label shall be dated and signed. For appliances containing flammable refrigerants, ensure that there are labels on the equipment stating the equipment contains flammable refrigerant.

Recovery

When removing refrigerant from a system, either for servicing or decommissioning, it is recommended good practice that all refrigerants are removed safely.

When transferring refrigerant into cylinders, ensure that only appropriate refrigerant recovery cylinders are employed. Ensure that the correct number of cylinders for holding the total system charge are available. All cylinders to be used are designated for the recovered refrigerant and labelled for that refrigerant (i.e. special cylinders for the recovery of refrigerant). Cylinders shall be complete with pressure-relief valve and associated shut-off valves in good working order. Empty recovery cylinders are evacuated and, if possible, cooled before recovery occurs.

The recovery equipment shall be in good working order with a set of instructions concerning the equipment that is at hand and shall be suitable for the recovery of all appropriate refrigerants including, when applicable, flammable refrigerants. In addition, a set of calibrated weighing scales shall be available and in good working order. Hoses shall be complete with leak-free disconnect couplings and in good condition. Before using the recovery machine, check that it is in satisfactory working order, has been properly maintained and that any associated electrical components are sealed to prevent ignition in the event of a refrigerant release. Consult manufacturer if in doubt.

The recovered refrigerant shall be returned to the refrigerant supplier in the correct recovery cylinder, and the relevant waste transfer note arranged. Do not mix refrigerants in recovery units and especially not in cylinders.

If compressors or compressor oils are to be removed, ensure that they have been evacuated to an acceptable level to make certain that flammable refrigerant does not remain within the lubricant. The evacuation process shall be carried out prior to returning the compressor to the suppliers. Only electric heating to the compressor body shall be employed to accelerate this process. When oil is drained from a system, it shall be carried out safely.

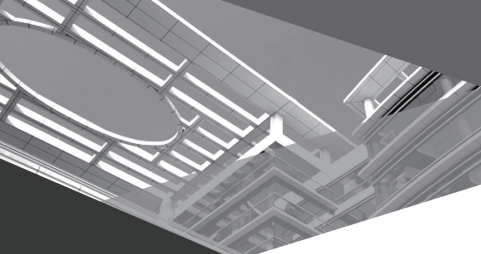

GREE ELECTRIC APPLIANCES, INC. OF ZHUHAI

Add: West Jinji Rd, Qianshan, Zhuhai, Guangdong, China, 519070

Tel: (+86-756) 8522218

Fax: (+86-756) 8669426

E-mail: gree@gree.com.cn

Web: www.gree.com



600005062185