

 **GREE**
[CENTRAL AIR CONDITIONERS]

R410A



**FREE MATCH II MULTI VRF
SERVICE MANUAL**

**T1/R410A/50Hz
(GC201106 -I)**

GREE ELECTRIC APPLIANCES INC.OF ZHUHAI

CONTENTS



PRODUCT	2
1 MODELS LIST	2
1.1 Outdoor Unit	2
1.2 Indoor Unit.....	2
2 NOMENCLATURE	4
2.1 Nomenclature of Outdoor Unit	4
2.2 Nomenclature of indoor unit	4
3 FUNCTION	5
4 PRODUCT DATA	6
4.1 Product data of outdoor.....	6
4.2 Product data of indoor	7
4.3 Working Temperature Range.....	12
5 PIPING DIAGRAM	13
CONTROL	15
1 OPERATION FLOWCHART	15
1.1 Cooling/Dehumidifying Operation	16
1.2 Heating Operation.....	17
2 MAIN LOGIC	18
2.1 Control Function of Outdoor Unit.....	18
2.2 Protection Function	19
2.3 other function.....	20
2.4 Control Function of Indoor Unit.....	20
3 REMOTE CONTROLLER	23
3.1 Wired Remote Controller	23
3.2 Wireless Remote Controller.....	28
INSTALLATION	33
1 PRECAUTIONS FOR INSTALLATION	33
1.1 Precautions for Installation	33
1.2 Key Points of Installation	34
2 FLOW CHART OF INSTALLATION.....	35
3 OUTDOOR UNIT INSTALLATION.....	36
3.1 Before Installation	36
3.2 Installation Site	36
3.3 Caution for Installation.....	36
3.4 Dimension Data	36
3.5 Installation Clearance Data.....	37
4 INDOOR UNIT INSTALLATION	38
4.1 Installation of Duct Type.....	38

4.2 Installation of Cassette Type.....	41
4.3 Installation of Floor Ceiling Type	47
5 REFRIGERATION PIPING WORK	50
5.1 Connection between Indoor and Outdoor Units.....	50
5.2 Refrigerant Charging and Trial Running	52
6 ELECTRIC WIRING WORK.....	55
6.1 Wiring Principle	55
6.2 Electric Wiring Design	55
6.3 Specification of Power Supply Wire and Air Switch	57
MAINTENANCE	59
1 TROUBLE TABLE.....	59
1.1 Please check the following items before contact the maintenance serviceman.....	59
1.2 The conditions listed below are not classified into errors	59
1.3 Error description	60
2 FLOW CHART OF TROUBLESHOOTING	64
3 WIRING DIADRAM.....	69
3.1 Outdoor unit	69
3.2 Indoor unit	70
4 DISASSEMBLY AND ASSEMBLY PROCEDURE OF MAIN PARTS	72
4.1 Outdoor Unit.....	72
4.2 Indoor Unit.....	74
5 EXPLODED VIEWS AND PART LIST	81
5.1 Outdoor Unit	81
5.2 Indoor Unit.....	85

PRODUCT

PRODUCT 1 MODELS LIST

1.1 Outdoor Unit



Units Series	Model	Product Code	Capacity		Ref.	Power Supply	Appearance
			Cooling (kW)	Heating (kW)			
Free Match Outdoor Unit	GWHD(36)NK3AO	CN860W0011	9.789	11	R410A	220~ 240V -1Ph-50Hz	
	GWHD(42)NK3AO	CN860W0020	11.6	13			

1.2 Indoor Unit

1.2.1 Duct type

Units Series	Model	Product Code	Capacity		Ref.	Power Supply	Appearance
			Cooling (kW)	Heating (kW)			
Free Match Duct Type Indoor Unit	GFH(09)EA-K3DNA1A/I	CN210N0010	2.5	2.80	R410A	220~ 240V -1Ph-50Hz	
	GFH(12)EA-K3DNA1A/I	CN210N0020	3.5	3.85			
	GFH(18)EA-K3DNA1A/I	CN210N0030	5.0	5.50			
	GFH(21)EA-K3DNA1A/I	CN210N0040	6.0	6.60			
	GFH(24)EA-K3DNA1A/I	CN210N0050	7.1	8.00			

1.2.2 Cassette type

Units Series	Model	Product Code	Capacity		Ref.	Power Supply	Appearance
			Cooling (kW)	Heating (kW)			
Free Match Cassette Type Indoor Unit	GKH(12)BA-K3DNA1A/I	CN510N0010	3.5	3.85	R410A	220~ 240V -1Ph-50Hz	
	GKH(18)BA-K3DNA1A/I	CN510N0020	5.0	5.50			
	GKH(24)BA-K3DNA1A/I	CN510N0030	7.1	8.00			
	GKH(12)BA-K3DNA2A/I	CN510N0040	3.5	4.0	R410A	220~ 240V -1Ph-50Hz	
	GKH(18)BA-K3DNA2A/I	CN510N0050	4.5	5.0			

1.2.3 Floor ceiling type

Units Series	Model	Product Code	Capacity		Ref.	Power Supply	Appearance
			Cooling (kW)	Heating (kW)			
Free Match Floor/Ceiling Type Indoor Unit	GTH(09)BA-K3DNA1A/I	CN610N0010	2.5	2.80	R410A	220~240V -1Ph-50Hz	
	GTH(12)BA-K3DNA1A/I	CN610N0020	3.5	3.85			
	GTH(18)BA-K3DNA1A/I	CN610N0030	5.0	5.50			
	GTH(24)BA-K3DNA1A/I	CN610N0040	7.1	8.00			

2 NOMENCLATURE

2.1 Nomenclature of Outdoor Unit

GW	□	□	(□)	□	□	□	□	O
1	2	3	4	5	6	7	8	9

NO.	Description	Options
1	GW	Free-Match Code
2	Cooling Function	C: Cooling Only H: Heat pump
3	Compressor Frequency	D:DC inverter rotor type
4	Cooling Capacity	36 represents 36000Btu/h 1kW=3.412KBtu
5	Climate Type	T1
6	Power Supply	M:380-415V-3Ph-50Hz; K:220-240V-1Ph-50Hz
7	Refrigerant	R410A
8	Design No.	A :First generation
9	O	Outdoor Unit Code O:Outdoor I:Indoor

2.2 Nomenclature of indoor unit

G	□	□	(□)	□	-	□	□	□	□	□	□	/	I
1	2	3	4	5		6	7	8	9	10	11		12

NO.	Description	Options
1	G	GREE
2	Product Type	F:Duct type K:Cassette type T:Floor ceiling type
3	Cooling Function	C: Cooling Only H: Heat pump
4	Cooling Capacity	12 represents 12000Btu/h 1kW=3.412KBtu
5	Series	Alphabets: Series code + Shell code
6	Power Supply	M:380-415V-3Ph-50Hz; K:220-240V-1Ph-50Hz
7	Refrigerant	R410A
8	Compressor Frequency	D:DC inverter rotor type
9	Climate Type	T1
10	Panel Code	1 Alphabet +1 Numeral
11	Design No.	A :First generation
12	I	Indoor Unit Code O:Outdoor I:Indoor

3 FUNCTION

Function		Duct type	Cassette type	Floor ceiling type
For Comfortable Air Conditioning	Fan operation Mode	•	•	•
	Auto Swing Controller	-	•	•
	Timer Selector	•	•	•
	Auto Mode Operation	•	•	•
	Cool Mode Operation	•	•	•
	Heat Mode Operation	•	•	•
	Dry Mode Operation	•	•	•
	Fan Mode Operation	•	•	•
	Sleep mode setting	•	•	•
	Drain Pump	•	•	-
For Flexible Control	Wired Controller	•	•	•
	Wireless Remote Controller	•	•	•

•:Have Functions

- :No Functions

4 PRODUCT DATA

4.1 Product data of outdoor

Model	Heat pump		GWHD(36)NK3AO	GWHD(42)NK3AO
	Product Code		CN860W0011	CN860W0020
Capacity	Cooling	kW	9.789	11.6
	Heating	kW	11	13
Capacity adjustment range		%	23% ~ 150%	19%~ 150%
EER		kW/kW	3.23	3.23
COP		kW/kW	3.65	3.67
Power supply		V-Ph-Hz	220~240-1-50	220~240-1-50
Refrigerant	Type		R410A	R410A
	Charge volume	kg	3.6	4.8
Compressor	Brand		MITSUBISHI	MITSUBISHI
	Type		DC inverter rotor type	DC inverter rotor type
	Quantity		1	1
Moisture protection			IP×4	IP×4
Wiring connection	Area*quantity	mm ²	6*3	6*3
Connecting pipe	Connection method		Flare Connection	Flare Connection
Sound pressure level		dB(A)	54	54
Outline dimension	W×D×H	mm	950×412×840	1015×440×1103
Package dimension	W×D×H	mm	1100×450×905	1155×490×1220
Net weight		kg	73	102
Gross weight		kg	78	112
Maximum drive IDU NO.		unit	4	5
Max. equivalent connection pipe length		m	70	80
Loading quantity		20'GP	52	22
		40' GP	108	48
		40' HQ	108	48

Notes:

- The rated cooling capacity data is measured under the following work condition: Indoor Temperature is 27°C DB, 19 °C WB. Outdoor Temperature is 35 °C DB. The rated heating capacity data is measured under the following work condition: Indoor Temperature is 20°C DB. Outdoor Temperature is 7°C DB, 6°C WB.
- The data will change with the change of products. Refer to those parameters listed on nameplate.
- Noise was tested in semi-silenced room, so the actual noise value will be a little higher for change of ambient.

4.2 Product data of indoor

4.2.1 Duct Type

Model	Heat pump		GFH(09)EA-K3DNA1A/I	GFH(12)EA-K3DNA1A/I	GFH(18)EA-K3DNA1A/I
	Product Code		CN210N0010	CN210N0020	CN210N0030
Capacity	Cooling	kW	2.5	3.5	5.0
	Heating	kW	2.80	3.85	5.50
Power supply		V-Ph-Hz	220 ~ 240-1- 50	220 ~ 240-1- 50	220 ~ 240-1- 50
Motor power input		kW	0.075	0.065	0.08
Air flow volume		m ³ /h	450	550	700
		CFM	265	324	412
Sound pressure level(H/L)		dB(A)	37/31	39/32	40/33
Fan motor	Output	kW	0.041	0.036	0.044
	Running current	A	0.406	0.348	0.428
Connecting pipe	Gas	inch	3/8"(Φ9.52mm)	3/8"(Φ9.52mm)	1/2"(Φ12.7mm)
	Liquid	inch	1/4"(Φ6.35mm)	1/4"(Φ6.35mm)	1/4"(Φ6.35mm)
	Connection method		Flare Connection	Flare Connection	Flare Connection
Drain pipe	External dia.	mm	Φ20	Φ20	Φ20
	Thickness	mm	1.5	1.5	1.5
Outline dimension	W×D×H	mm	700×615×200	700×615×200	900×615×200
Package dimension	W×D×H	mm	893×743×305	893×743×305	1123×743×305
Net Weight		kg	22	23	27
Gross weight		kg	27	29	36
Loading quantity		20'GP	108	108	90
		40' GP	234	234	180
		40' HQ	234	234	180

Notes:

- The rated cooling capacity data is measured under the following work condition: Indoor Temperature is 27°C DB, 19 °C WB. Outdoor Temperature is 35 °C DB. The rated heating capacity data is measured under the following work condition: Indoor Temperature is 20°C DB. Outdoor Temperature is 7°C DB, 6°C WB.
- The data will change with the change of products. Refer to those parameters listed on nameplate.
- Noise was tested in semi-silenced room, so the actual noise value will be a little higher for change of ambient.

Model	Heat pump		GFH(21)EA-K3DNA1A/I	GFH(24)EA-K3DNA1A/I
	Product Code		CN210N0040	CN210N0050
Capacity	Cooling	kW	6.0	7.1
	Heating	kW	6.60	8.00
Power supply		V-Ph-Hz	220~240-1-50	220~240-1-50
Motor power input		kW	0.11	0.11
Air flow volume		m ³ /h	1000	1000
		CFM	589	589
Sound pressure level(H/L)		dB(A)	42/34	42/34
Fan motor	Output	kW	0.061	0.061
	Running current	A	0.588	0.588
Connecting pipe	Gas	inch	5/8"(Φ15.9mm)	5/8"(Φ15.9mm)
	Liquid	inch	3/8"(Φ9.52mm)	3/8"(Φ9.52mm)
	Connection method		Flare Connection	Flare Connection
Drain pipe	External dia.	mm	Φ20	Φ20
	Thickness	mm	1.5	1.5
Outline dimension	W×D×H	mm	1100×615×200	1100×615×200
Package dimension	W×D×H	mm	1323×743×305	1323×743×305
Net Weight		kg	31	31
Gross weight		kg	41	41
Loading quantity		20'GP	72	72
		40' GP	162	162
		40' HQ	162	162

Notes:

- The rated cooling capacity data is measured under the following work condition: Indoor Temperature is 27°C DB, 19 °C WB. Outdoor Temperature is 35 °C DB. The rated heating capacity data is measured under the following work condition: Indoor Temperature is 20°C DB. Outdoor Temperature is 7°C DB, 6°C WB.
- The data will change with the change of products. Refer to those parameters listed on nameplate.
- Noise was tested in semi-silenced room, so the actual noise value will be a little higher for change of ambient.

4.2.2 Cassette type

Model	Heat pump		GKH(12)BA-K3DNA1A/I	GKH(18)BA-K3DNA1A/I	GKH(24)BA-K3DNA1A/I
	Product Code		CN510N0010	CN510N0020	CN510N0030
Capacity	Cooling	kW	3.5	5	7.1
	Heating	kW	3.85	5.50	8.00
Power supply		V-Ph-Hz	220~240-1-50	220~240-1-50	220~240-1-50
Motor power input		kW	0.07	0.07	0.1
Air flow volume		m ³ /h	680	680	1180
		CFM	400	400	694
Sound pressure level(H/L)		dB(A)	37/33	37/33	39/35
Fan motor	Output	kW	0.0385	0.0385	0.055
	Running current	A	0.374	0.374	0.535
Connecting pipe	Gas	inch	3/8"(Φ9.52mm)	1/2"(Φ12.7mm)	5/8"(Φ15.9mm)
	Liquid	inch	1/4"(Φ6.35mm)	1/4"(Φ6.35mm)	3/8"(Φ9.52mm)
	Connection method		Flare Connection	Flare Connection	Flare Connection
Drain pipe	External dia.	mm	Φ31	Φ31	Φ31
	Thickness	mm	3	3	3
Outline Dimension	Body(W×D×H)	mm	840×840×190	840×840×190	840×840×240
	Panel(W×D×H)	mm	950×950×60	950×950×60	950×950×60
Package Dimension	Body(W×D×H)	mm	963×963×273	963×963×273	963×963×325
	Panel(W×D×H)	mm	1043×1028×130	1043×1028×130	1043×1028×130
Net Weight	Body	kg	25	25	30
	Panel	kg	6.5	6.5	6.5
Gross Weight	Body	kg	33	33	38
	Panel	kg	10	10	10
Loading quantity		20'GP	72	48	40
		40' GP	128	128	108
		40' HQ	144	144	128

Notes:

a. The rated cooling capacity data is measured under the following work condition: Indoor Temperature is 27°C DB, 19 °C WB. Outdoor Temperature is 35 °C DB. The rated heating capacity data is measured under the following work condition: Indoor Temperature is 20°C DB. Outdoor Temperature is 7°C DB, 6°C WB.

b. The data will change with the change of products. Refer to those parameters listed on nameplate.

c. Noise was tested in semi-silenced room, so the actual noise value will be a little higher for change of ambient.

Model	Heat pump		GKH(12)BA-K3DNA2A/I	GKH(18)BA-K3DNA2A/I
	Product Code		CN510N0040	CN510N0050
Capacity	Cooling	kW	3.5	4.5
	Heating	kW	4.0	5.0
Power supply		V-Ph-Hz	220~240-1-50	220~240-1-50
Motor power input		kW	0.05	0.05
Air flow volume		m ³ /h	600	600
		CFM	353	353
Sound pressure level(H/L)		dB(A)	46	46
Fan motor	Output	kW	0.011	0.011
	Running current	A	0.25	0.25
Connecting pipe	Gas	inch	3/8"(Φ9.52mm)	1/2"(Φ12.7mm)
	Liquid	inch	1/4"(Φ6.35mm)	1/4"(Φ6.35mm)
	Connection method		Flare Connection	Flare Connection
Drain pipe	External dia.	mm	Φ31	Φ31
	Thickness	mm	3	3
Outline Dimension	Body(W×D×H)	mm	570×570×230	570×570×230
	Panel(W×D×H)	mm	650×650×50	650×650×50
Package Dimension	Body(W×D×H)	mm	851×731×325	851×731×325
	Panel(W×D×H)	mm	733×673×117	733×673×117
Net Weight	Body	kg	18	18
	Panel	kg	6.5	6.5
Gross Weight	Body	kg	23	23
	Panel	kg	10	10
Loading quantity		20'GP	102	102
		40' GP	209	209
		40' HQ	246	246

Notes:

- The rated cooling capacity data is measured under the following work condition: Indoor Temperature is 27°C DB, 19 °C WB. Outdoor Temperature is 35 °C DB. The rated heating capacity data is measured under the following work condition: Indoor Temperature is 20°C DB. Outdoor Temperature is 7°C DB, 6°C WB.
- The data will change with the change of products. Refer to those parameters listed on nameplate.
- Noise was tested in semi-silenced room, so the actual noise value will be a little higher for change of ambient.

4.2.3 Floor ceiling type

Model	Heat pump		GTH(09)BA-K3DNA1A/I	GTH(12)BA-K3DNA1A/I
	Product Code		CN610N0010	CN610N0020
Capacity	Cooling	kW	2.5	3.5
	Heating	kW	2.8	3.85
Power supply		V-Ph-Hz	220~240-1-50	220~240-1-50
Motor power input		kW	0.055	0.055
Air flow volume		m ³ /h	650	650
		CFM	383	383
Sound pressure level(H/L)		dB(A)	40/36	40/36
Fan motor	Output	kW	0.3	0.3
	Running current	A	0.297	0.297
Connecting pipe	Gas	inch	3/8"(Φ9.52mm)	3/8"(Φ9.52mm)
	Liquid	inch	1/4"(Φ6.35mm)	1/4"(Φ6.35mm)
	Connection method		Flare Connection	Flare Connection
Drain pipe	External dia.	mm	Φ17	Φ17
	Thickness	mm	1.75	1.75
Outline dimension	W×D×H	mm	1220×700×225	1220×700×225
Package dimension	W×D×H	mm	1343×823×315	1343×823×315
Net Weight		kg	40	40
Gross weight		kg	50	50
Loading quantity		20'GP	48	48
		40' GP	96	96
		40' HQ	96	96

Notes:

- The rated cooling capacity data is measured under the following work condition: Indoor Temperature is 27°C DB, 19 °C WB. Outdoor Temperature is 35 °C DB. The rated heating capacity data is measured under the following work condition: Indoor Temperature is 20°C DB. Outdoor Temperature is 7°C DB, 6°C WB.
- The data will change with the change of products. Refer to those parameters listed on nameplate.
- Noise was tested in semi-silenced room, so the actual noise value will be a little higher for change of ambient.

Model	Heat pump		GTH(18)BA-K3DNA1A/I	GTH(24)BA-K3DNA1A/I
	Product Code		CN610N0030	CN610N0040
Capacity	Cooling	kW	5	7.1
	Heating	kW	5.5	8.0
Power supply		V-Ph-Hz	220~240-1-50	220~240-1-50
Motor power input		kW	0.11	0.11
Air flow volume		m ³ /h	950	1250
		CFM	559	736
Sound pressure level(H/L)		dB(A)	45/40	48/40
Fan motor	Output	kW	0.061	0.061
	Running current	A	0.588	0.588
Connecting pipe	Gas	inch	1/2"(Φ12.7mm)	5/8"(Φ15.9mm)
	Liquid	inch	1/4"(Φ6.35mm)	3/8"(Φ9.52mm)
	Connection method		Flare Connection	Flare Connection
Drain pipe	External dia.	mm	Φ17	Φ17
	Thickness	mm	1.75	1.75
Outline dimension	W×D×H	mm	122×700×225	1220×700×225
Package dimension	W×D×H	mm	1343×823×315	1343×823×315
Net Weight		kg	40	45
Gross weight		kg	50	54
Loading quantity		20'GP	48	48
		40' GP	96	96
		40' HQ	96	96

Notes:

- The rated cooling capacity data is measured under the following work condition: Indoor Temperature is 27°C DB, 19 °C WB. Outdoor Temperature is 35 °C DB. The rated heating capacity data is measured under the following work condition: Indoor Temperature is 20°C DB. Outdoor Temperature is 7°C DB, 6°C WB.
- The data will change with the change of products. Refer to those parameters listed on nameplate.
- Noise was tested in semi-silenced room, so the actual noise value will be a little higher for change of ambient.

4.3 Working Temperature Range

	Indoor side state		Outdoor side state	
	Dry bulb temp. °C	Wet bulb temp. °C	Dry bulb temp. °C	Wet bulb temp. °C
Rated Cooling	27	19	35	24
Max. cooling	32	23	48	26
Min. cooling	21	15	18	—
Rated Heating	20	15	7	6
Max. heating	27	—	24	18
Min. heating	20	15	— 15	— 16

Notes:

- The heating/cooling capacity and noise listed below are all measured before the shipment.
- All parameters listed below are measured under the standard working conditions. If there is any change, the parameters marked on the nameplate always prevail.
- The heating capacity of the indoor unit just involves that of the heat pump but apart from that of the auxiliary electric heater.

5 PIPING DIAGRAM

Schematic Diagram of Free Match Series Inverter Heat Pump Multi VRF System

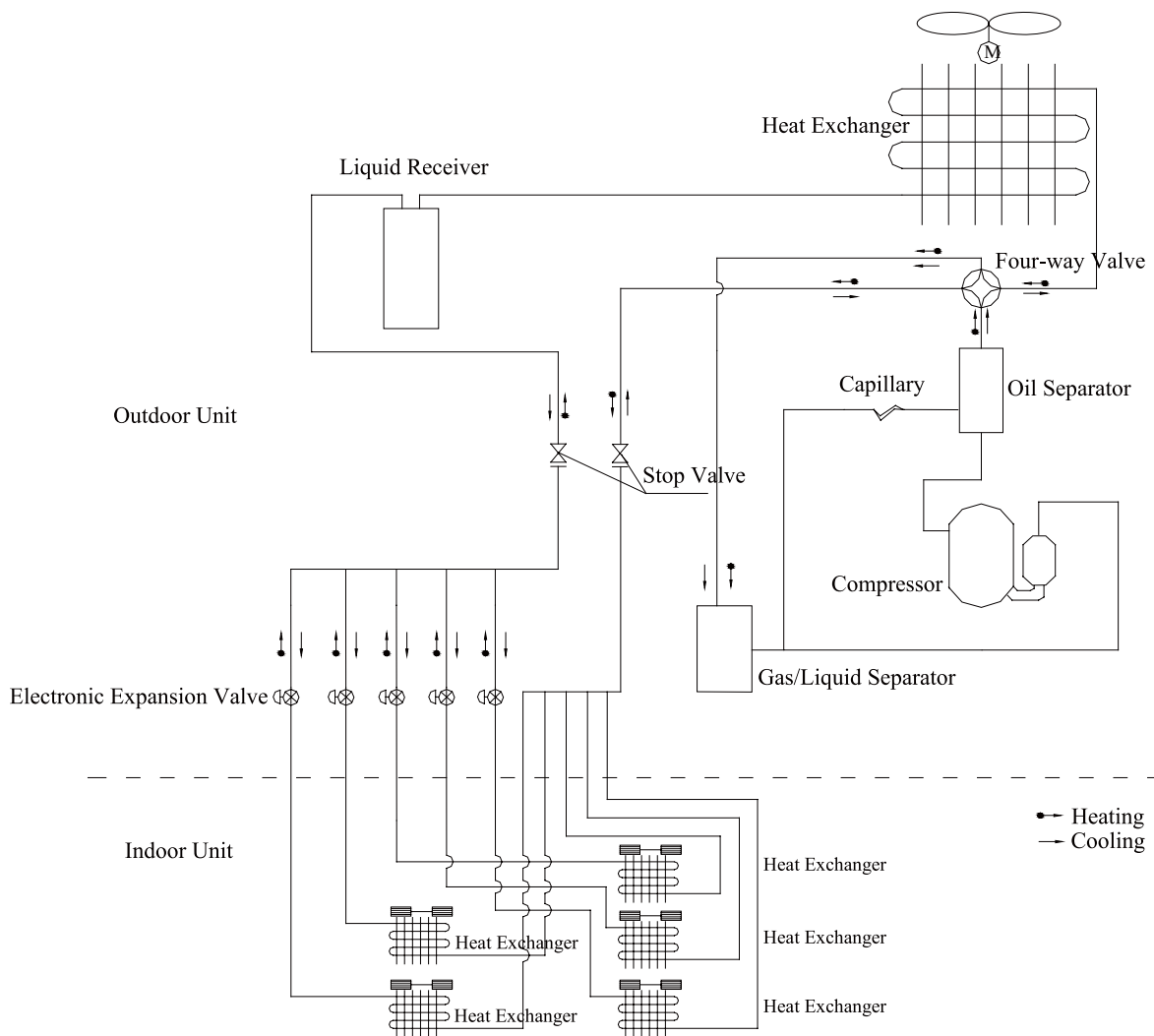

Schematic Diagram of Free Match Series Inverter Heat Pump Multi VRF System

The outdoor and indoor units start to work once the power is switched on. During the cooling operation, the low temperature, low pressure refrigerant gas from the heat exchanger of each indoor unit gets together and then is taken into the compressor to be compressed into high temperature, high pressure gas, which will soon go to the heat exchanger of the outdoor unit to exchange heat with the outdoor air and then is turned into refrigerant liquid. After passing through the throttling device, the temperature and pressure of the refrigerant liquid will further decrease and then go to the main valve. After that, it will be divided and go to the heat exchanger of each indoor unit to exchange heat with the air which needs to be conditioned. Consequently, the refrigerant liquid become low temperature, low pressure refrigerant gas again. Such a refrigeration cycle goes round and round to achieve the desired refrigeration purpose. During the heating operation, the four-way valve is involved to make the refrigeration cycle run reversely. The refrigerant radiates heat in the heat exchanger of the indoor unit (so do the electric heating devices) and absorb heat in the heat exchanger of the outdoor unit for a heat pump heating cycle so as to achieve the desired heating purpose.



CONTROL

CONTROL 1 OPERATION FLOWCHART

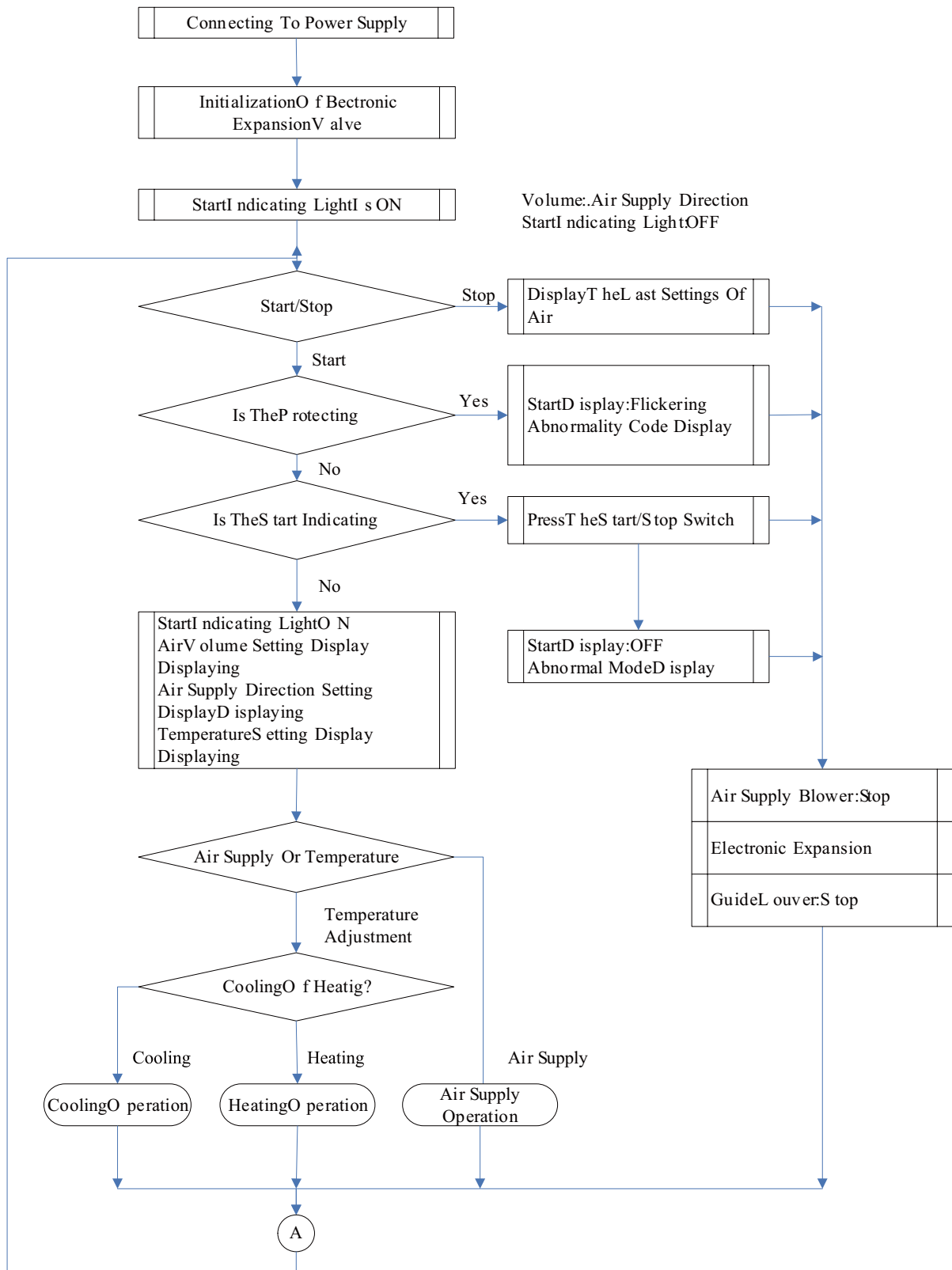

1.1 Cooling/Dehumidifying Operation

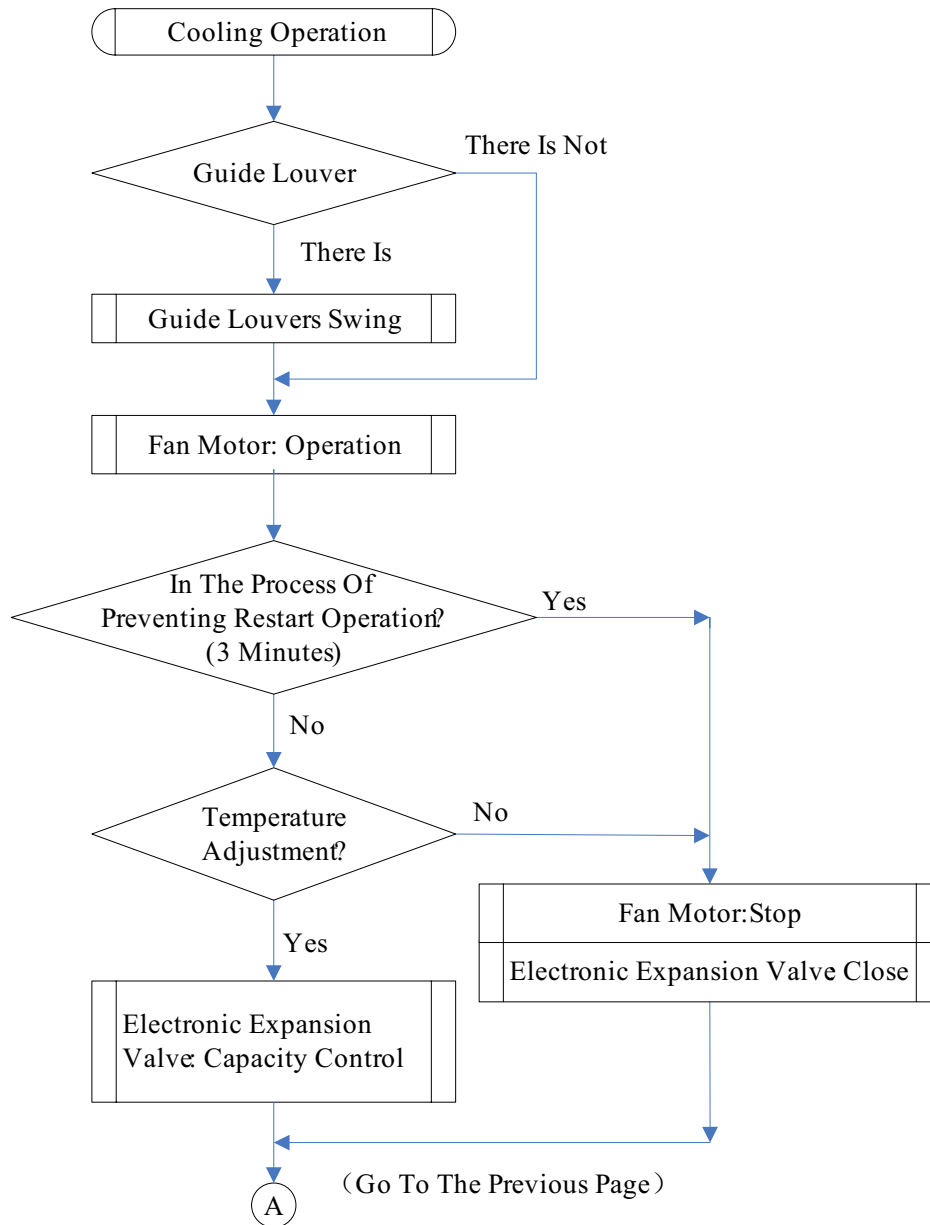

1.2 Heating Operation

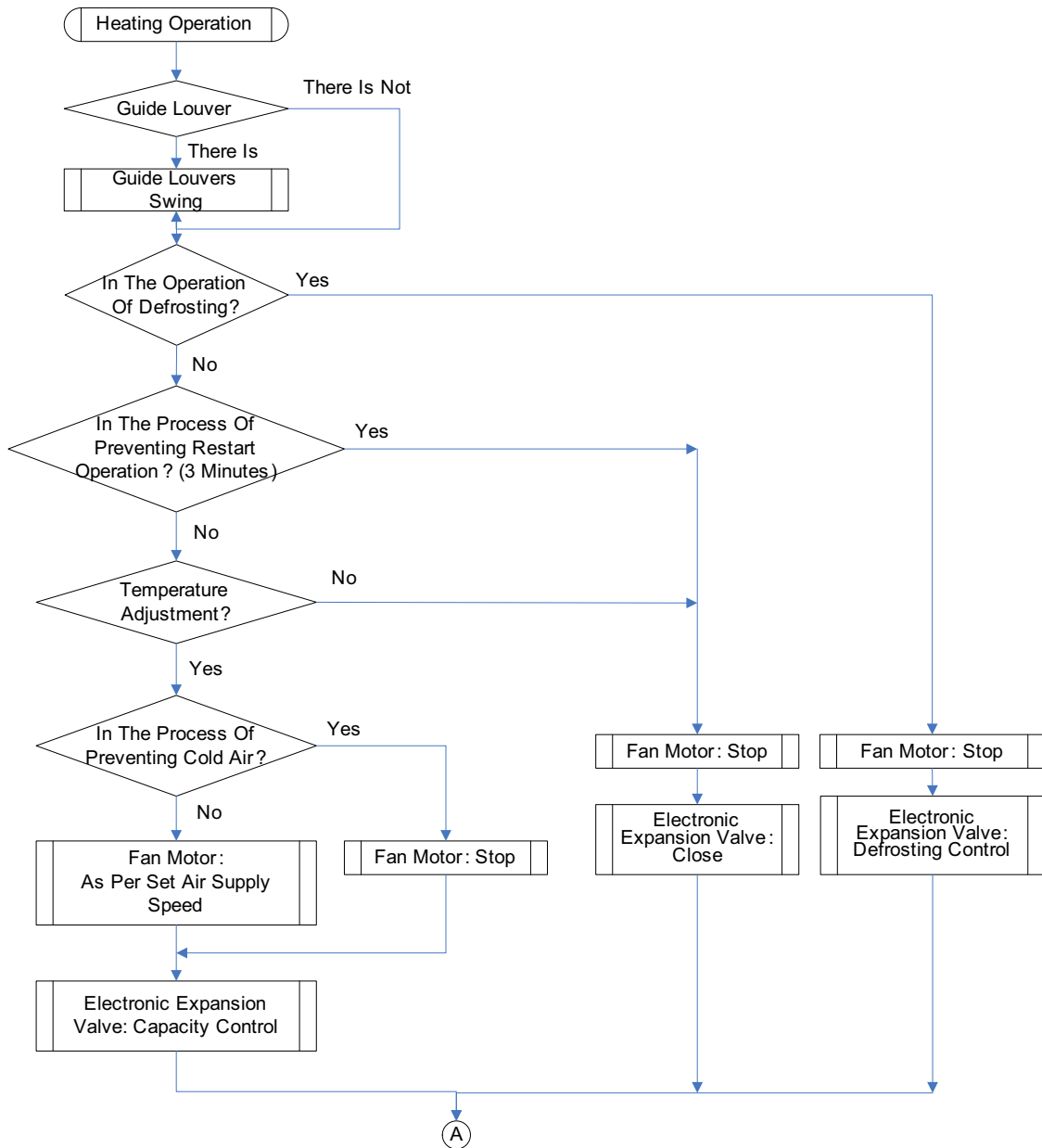

2 MAIN LOGIC

2.1 Control Function of Outdoor Unit

2.1.1 Cooling Mode

- a. Cooling conditions and process:

If the compressor is in stop status and start the unit for cooling operation, when one of the indoor units reaches the cooling operation condition, the unit start cooling operation; in this case, the electronic expansion valve, the outdoor fan and the compressor start operation.

- b. Stop in cooling operation

- a) Compressor stops

The compressor stops gradually, the outdoor fan stops after 1min.

b) Some of the indoor units reach the stop condition (the compressor does not stop) The compressor operates according to the required frequency. For the indoor unit with no requirement, the corresponding electronic expansion valve is closed to 0P.

- c. Cooling mode transfers to heating mode

When the unit transfers to heating mode, the 4-way valve is energized after the compressor runs for 40s. The other disposals are the same as stopping in cooling mode.

- d. 4-way valve:

In this mode, the 4-way valve is closed.

- e. Outdoor fan control in cooling mode

The outdoor fan starts before 5s of the starting of compressor. The outdoor fan will run in high speed for 40s after starting and then it will run in set speed.

The fan shall run at every speed for at least 80s. (when indoor units quantity changes, the control part will adjust the outdoor fan according to the indoor units quantity and outdoor temperature.); When the compressor stops, the outdoor fan runs at present speed and stops after 1min.

2.1.2 Dry Mode

- a. The dry conditions and process are the same as those in cooling mode;

- b. The status of 4-way valve: closed;

- c. The temperature setting range: 16 ~ 30°C ;

- d. Protection function: the same as those in cooling mode;

e. In dry mode, the maximum value A of the capacity requirement percentage of single unit is 90% of that in cooling mode. The open condition of the electronic expansion valve, outdoor fan and compressor is the same as those in cooling mode.

2.1.3 Heating Mode

a. Heating conditions and process: When one of the indoor units reaches the heating operation condition, the unit starts heating operation.

- b. Stop in heating operation:

- a) When all the indoor units reach the stop condition, the compressor stops and the outdoor fan stops after 1min;

b) Some of the indoor units reach the stop condition The compressor reduces the frequency immediately and operates according to the required frequency;

- c) Heating mode transfers to cooling mode(dry mode), fan mode

The compressor stops;

The outdoor fan stops after 1min;

The status of 4-way valve: energized;

- c. Outdoor fan control in heating mode

The outdoor fan starts before 5s of the starting of compressor and then it will run in high speed for 40s; The fan shall run at every speed for at least 80s; When the compressor stops, the outdoor fan stops after 1min.

- d. Defrosting function

When the defrosting condition is met, the frequency of the compressor starts to decrease and wait for defrosting; the electronic expansion valve of all indoor units open in big angle; the outdoor fan stops after the stop of the 4-way valve, meanwhile, the 4-way valve reverses the direction; after the 4-way valve reverses the direction, the frequency of the compressor starts to rise; then begin to calculate the time of defrosting, the frequency of the compressor rises to reach the defrosting frequency.

- e. Oil-returned control in heating mode

- a) Oil-returned condition

The whole unit is operating in low frequency for a long time

- b) Oil-returned process in heating mode
The indoor unit displays “H1”
- c) Oil-returned finished condition in heating mode
The duration reaches 5min

2.1.4 Fan Mode

The compressor, the outdoor fan and the 4-way valve are closed; temperature setting range is 16 ~ 30°C .

2.2 Protection Function

2.2.1 Mode Conflict Protection of indoor unit

When the setting mode is different of different indoor unit, the unit runs in below status:

- a. The mode of the first operating indoor unit is the basic mode, then compare the mode of the other indoor units to see if there is a conflict. Cooling mode (dry mode) is in conflict with heating mode.
- b. Fan mode is in conflict with heating mode and the heating mode is the basic mode. No matter which indoor unit operates first, the unit will run in heating mode.

2.2.2 Overload Protection Function

When the tube temperature is a little low, the compressor raises the operation frequency; when the tube temperature is a little high, the compressor frequency is restricted or lows down the operation frequency; when the tube temperature is too high, the compressor protection stops running. If the discharge temperature protection continuously appears for 6 times, the compressor can't resume running. The compressor can resume running after cutting off the power and then putting through the power. (if the running time of the compressor is longer than 7min, the protection times record will be cleared)

2.2.3 Discharge Protection Function

When the discharge temperature is a little low, the compressor raises the operation frequency; when the discharge temperature is a little high, the compressor frequency is restricted or lows down the operation frequency; when the discharge temperature is too high, the compressor protection stops running. If the discharge temperature protection continuously appears for 6 times, the compressor can't resume running. The compressor can resume running after cutting off the power and then putting through the power. (if the running time of the compressor is longer than 7min, the protection times record will be cleared)

2.2.4 Communication malfunction

Detection of the quantity of installed indoor units: After 3min of energizing, if the outdoor unit does not receive the communication data of certain indoor unit, the outdoor unit will judge that indoor unit is not installed and will treat it as it is not installed. If the outdoor unit receives the communication data of that indoor unit later, the outdoor unit will treat that unit as it is installed.

2.2.5 Compressor high-pressure protection

- a. When the high-pressure switch is detected cut off for 3s continuously, the compressor will enter high-pressure protection as it stops when reaching set temperature. Meanwhile, the outdoor unit will send the signal of “high-pressure protection” to the indoor units;
- b. After the appearance of high-pressure protection, the compressor can resume running only after cutting off the power and then putting through the power.

2.2.6 Compressor low-pressure protection

a. Low Pressure Protection for Shutdown

After the compressor stops for five minutes, if it is detected that the low pressure protection switch is opened, then a low pressure protection signal will be send out.

If it is detected continuously for three seconds that the low pressure protection switch is opened after the compressor stops for less than five minutes, then a low pressure protection signal will be send out. However, if the low pressure protection occurs twice in one hour, then it becomes unrecoverable and has to be recovered by powering the outdoor unit again.

b. Low Pressure Protection during the Operation

- a) When it is detected continuously for three seconds that the low pressure protection switch is opened, then the

whole unit should be shut off and a low pressure protection signal should be sent to the indoor unit.

b) On condition that a low pressure protection error occurs and the whole unit has stopped for more than three minutes and it is detected continuously for six seconds that the low pressure protection switch is closed, then this error can be eliminated. However, if the low pressure protection occurs twice in one hour, then it has to eliminate the error by powering the outdoor unit again.

2.2.7 Compressor overload protection

If the compressor overload switch is detected having movement, the indoor unit will display the corresponding malfunction as it stops when the indoor temperature reaching set temperature. When the compressor stops for more than 3min and the compressor overload switch is reset, the unit will resume operation status automatically. If the protection appears for more than 6 times (if the running time of the compressor is longer than 30min, the protection times record will be cleared), the unit can not resume operation status automatically, but can resume running only after cutting off the power and then putting through the power.

2.3 other function

Refrigerant Recovery

The refrigerant can be recovered from either the indoor unit or the outdoor unit.

When the unit is powered on and runs under the COOL mode, it is available within five minute to go the refrigerant recovery mode by pressing three times the "LIGHT" button on the wireless controller in three seconds with "Fo" displayed.

How to quit the refrigerant recovery:

When the refrigerant recovery has started, it will quit when there is a signal from the wireless controller or it has run for ten minutes.

2.4 Control Function of Indoor Unit

2.4.1 Running Mode

1.COOL 2.DRY 3.HEAT 4.AUTO 5.FAN

2.4.2 Basic Functions of the System

a. COOL Mode

Under this mode, the fan and swing function goes as the set conditions, and the set temperature range is 16°C ~30°C .

b. DRY Mode

Under this mode, the fan will run at the low speed and the swing function is performed under the set conditions. The set temperature range is 16~30°C .

c. FAN Mode

Under this mode, only the fan of the indoor unit runs. And if the auto speed is set, the fan will run under the same condition as the COOL mode.

d. HEAT Mode

a) Under this mode, the set temperature rang is 16°C ~30°C .

b) The defrosting symbol "H1" will be displayed when the defrosting signal is received from the outdoor unit.

e. AUTO Mode

a) When the ambient temperature is higher than 25°C , the unit will run as the COOL mode.

b) For the cooling and heating unit, if the ambient temperature is or lower than 22°C , the unit will run as the HEAT mode.

c) When the indoor ambient temperature is higher than 22°C but lower than 26°C , the unit which starts to work under the AUTO or DRY mode will shift to the FAN mode, while the unit which starts to work under other mode will keep the current running mode.

2.4.3 Other Control

a. Beeper Control

When the controller is powered on or it receives a valid either press button signal or remote control signal, the beeper will utter a warning tone.

b. Auto Speed Control

Under the HEAT mode:

If the ambient temperature is equal or higher than the set temperature, the fan will run at the low speed;

If the ambient temperature minus 3 °C is equal or lower than the set temperature, the fan will run at the medium

speed;

If the ambient temperature minus 3°C is lower than the set temperature minus 3°C, the fan will run at the high speed.

Under the COOL mode:

If the ambient temperature is equal to or lower than the set temperature, the fan will run at the low speed;

If the ambient temperature is between the set temperature and the set temperature minus 3°C, the fan will run at the medium speed;

If the ambient temperature is higher than the set temperature plus 3°C, the fan will run at the high speed.

Under the FAN mode:

The fan will run at the medium speed constantly.

Once the fan starts, its speed can not be changed until it has run for at least 30 seconds at the currently set speed.

Duct Type Unit, Cassette Type Unit, Floor Ceiling Unit

a) Under the HEAT Mode: (Ambient temperature herein is the temperature without temperature compensation)

When the ambient temperature is or lower than the set temperature, the indoor unit runs at the high speed.

When the ambient temperature is higher than the set temperature but lower than the set temperature plus 2°C, the indoor unit fan runs at the medium speed.

When the ambient temperature is or lower than the set temperature plus 2°C, the fan runs at the low speed.

b) Under the COOL and FAN Modes

When the ambient temperature is or higher than the set temperature plus 3°C, the indoor unit runs at high speed.

When the ambient temperature is higher than the set temperature plus 1°C but lower than the set temperature plus 3°C, the indoor unit fan runs at the medium speed.

When the ambient temperature is or lower than the set temperature plus 1°C, the fan runs at the low speed.

c) Once the fan starts at a certain speed, it will keep running at this speed for no less than 30 seconds prior to any changeover stated above.

c. AUTO Press Button

The whole unit will run under the AUTO mode by pressing this button when the unit is off. In this condition, the fan of the indoor unit will run at the auto speed with the swing function activated. When the unit is on, it will be turned off by pressing this button. This button is unavailable to the floor/ceiling unit.

d. Sleep

Under this mode, the proper sleep curve will be adopted in accordance with different set temperatures.

Under the COOL mode or the DRY mode, the temperature will go up by 1°C after one hour and by another 1°C after another hour, after that, the temperature will be kept on.

Under the HEAT mode, the temperature will go down by 1°C after one hour and by another 1°C after another hour, after that, the temperature will be kept on.

e. Timer

a) Timer On

When the unit is powered on but in the idle condition, it is available to set when to start the unit. Then, when the unit starts, it will run as the previously set mod. The set range of the timer is 0.5 ~ 24 hours with an interval of 0.5 hour.

b) Timer Off

When the unit is on, it is available to set when to stop the unit. The set range of timer is 0.5 ~ 24 hours with an interval of 0.5 hour.

f. Memory

a) Memorizing Objects: modes (AUTO, COO, DRY, FAN, HEAT), swing, set temperature, set fan speed, etc.

b) When the indoor unit works without the wired controller, it will resume the working condition as the power failure occurs after it is powered on again. When the indoor unit is with the wired controller, it is available to set the memory function by pressing the corresponding buttons of the wired controller.

c) When the indoor unit works without the wired controller, if the timer is not set for the last remote control instruction, the system will memorize this last instruction and works following it; if the timer is set, it will be canceled as the power failure occurs and will have to be reset.

d) When the indoor unit works with the wired controller, it will work as the message sent by the wired controller after it is powered on again.

g. Selection of the Indoor Temperature Sensor

a) For the duct type indoor unit: Under the COOL, HEAT, DRY, or FAN mode, the return air temperature sensor is adopted; while under the HEAT mode, it is the receiver temperature sensor.



For the cassette type, floor/ceiling type indoor unit: Under all modes, the return air temperature sensor is adopted.

b) When the duct type, cassette type, or the floor/ceiling type indoor unit works with the wired controller, the ambient temperature sensor can be set in the following four ways:

① 01: The indoor temperature sensor is set for the return air.

② 02: The indoor temperature sensor is set for the wired controller.

③ 03: The indoor temperature sensor is set for the wired controller under the HEAT mode, and for the return air under any other mode.

④ 04: The indoor temperature sensor is set for the return air under the HEAT mode, and for the wired controller under any other mode.

c) Setting of the Ambient Temperature Sensor of the Wired Controller XK19.

When the unit is off, it is available to go to the debugging status by pressing the “Function” and “Timer” buttons for five seconds, and the corresponding code will be displayed on the temperature area of the wired controller. There are four kinds of codes which can be adjusted through the “▼”/“▲” button.

The third one is the default code. The setting of the ambient temperature sensor of the wired controller should be memorized.

The “Enter/Cancel” button shall be pressed to confirm and leave the setting. If there is no response to the last button press within 20 seconds, then the system will quit the setting and go to the normal “Off” status but with the setting still saved.

h. Switchover of the Defrosting Mode

On condition that the unit is off, if “H1” is not displayed on the wireless controller, then the unit will go to the setting status of the “Defrosting Mode 1” as it is turned on through the wired controller. Then, once the indoor unit receives this signal, it will soon send it to the outdoor unit. In contrast, if “H1” is displayed, the unit will go the setting status of the “Defrosting Mode 2”, and the indoor unit also will send this signal to the outdoor unit as soon as it receives it.

On condition that the unit is off, it is available to switch over the “Defrosting Mode 1” and “Defrosting Mode 2” by pressing the “MODE” and “BLOW” buttons simultaneously.

i. Turbo

As soon as the controller receives the “Turbo” instruction, the fan of the indoor unit will run at the high speed.

j. Blow

Blow Function: It is a function to automatically blow off the moist inside the exchanger of the indoor unit to prevent mould growing after the unit is shut off.

a) On condition that this function is activated, when the “On/Off” press button is operated, the fan of the indoor unit will still run for ten minutes (with the symbol “BLOW” displayed). At this time, the fan will stop as this function is deactivated.

b) This function is unavailable under the AUTO, FAN, and HEAT modes.

3 REMOTE CONTROLLER

3.1 Wired Remote Controller

3.1.1 Wired Controller XK19

It is optional for the cassette type, wall-mounted, and floor ceiling indoor units.
Outside View of the Wired Controller



Outside View of the Wired Controller

LCD of the Wired Controller

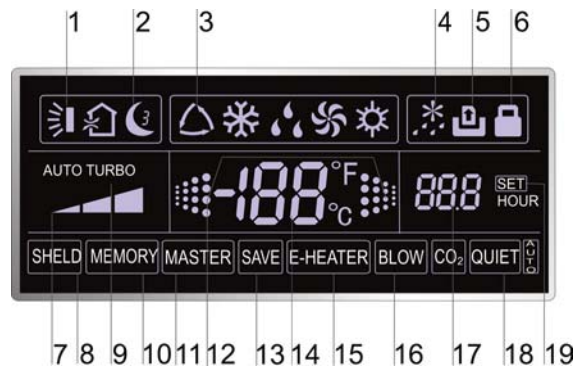

LCD of the Wired Controller

No.	Symbols	Description
1		Swing function.
2		Sleep function
3		Running modes of the indoor unit (Cooling, Dry, Fan, Heating and Auto).
4		Defrosting function for the outdoor unit.
5		Gate-control function.(this function is yet unavailable for this unit)
6		Lock function.
7		High, middle, low or auto fan speed of the indoor unit.
8	SHIELD	Shield functions (buttons, temperature, On/Off, Mode or Save is shielded or Save is shielded by the remote monitor)
9	TURBO	Turbo function.
10	MEMORY	Memory function (The indoor unit resumes the original setting state after power failure and then power recovery).
11	MASTER	Master wired controller (this function is yet unavailable for this unit).
12		It blinks under on state of the unit without operation of any button.
13	SAVE	Energy-saving function. (this function is yet unavailable for this unit)
14		Ambient/preset temperature value.
15	E-HEATER	Electric auxiliary heating function. (this function is yet unavailable for this unit)
16	BLOW	Blow function.
17		Timing value.
18	QUITE	Quiet function (two types: quiet and auto quiet). (this function is yet unavailable for this unit)
19	SET	It will be displayed under the debugging mode.

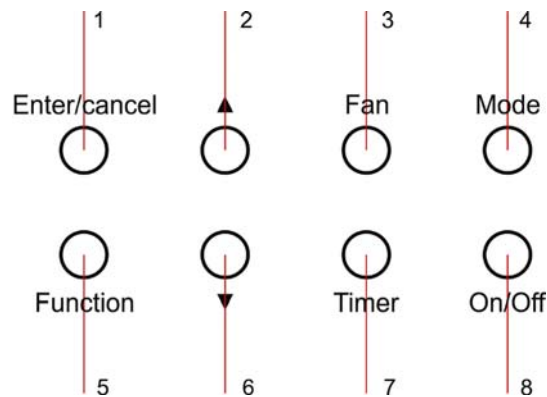

3.1.2 Buttons

Buttons on the Wired Controller



Buttons on the Wired Controller

Function of the Buttons

No.	Name	Function
1	Enter/cancel	① Function selection and cancellation. ② Press it for 5s to examine the outdoor ambient temperature.
2	▲	① Running temperature setting of the indoor unit, range:16 ~ 30°C . ② Timer setting, range:0.5-24 hr.
6	▼	
3	Fan	Setting of the high/middle/low/auto fan speed.
4	Mode	Setting of the Cooling/Heating/Fan/Dry mode of the indoor unit.
5	Function	Switchover among the functions of Swing/Sleep/Turbo/Save/E-heater/Blow /Quiet etc.
7	Timer	Timer setting.
8	On/Off	Turn on/off the indoor unit.
4+2	▲+Mode	Press them for 5s under off state of the unit to enter/cancel the Memory function (If memory is set, indoor unit after power failure and then power recovery will resume the original setting state.If not, the indoor unit is defaulted to be off after power recovery. Memory off is default before delivery.).
3 +6	Fan+▼	By pressing them at the same time under off state of the unit,  will be displayed on the wired controller for the cooling only unit, while  will be displayed on the wired controller for the cooling and heating unit.
2 +6	▲+▼	Upon startup of the unit without malfunction or under off state of the unit,press them at the same time for 5s to enter the lock state, in which case, any other buttons won't respond the press. Repress them for 5s to quit this state.

3.1.3 Operation Instructions

◆ On/Off

Press On/Off to turn on the unit and turn it off by another press.

◆ Mode Setting

Under the “On” state of the unit, press Mode to switch the operation modes as the following sequence: Cooling-Dry-Fan-Heating.

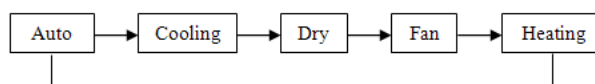

◆ Temperature Setting

Press ▲ or ▼ to increase/decrease the preset temperature. If press either of them continuously, the temperature will be increased or decreased by 1°C every 0.5s.

In the Cooling, Dry or Heating mode, the temperature setting range is 16°C ~ 30°C .

In the Fan mode, the setting temperature is fixed at 26°C .

In the Auto mode, the setting temperature is unadjustable.

◆ Fan Setting

Under the “On”/“Off” state of the unit, press Fan and then fan speed of the indoor unit will change circularly.

◆ Timer Setting

Under the “On”/“Off” state of the unit, press Timer to set timer off/on.

Timer on setting: press Timer, and then LCD will display “xx.x hour”, with “hour” blinking. In this case, press ▲ or ▼ to adjust the timing value. Then press Enter/cancel to confirm the setting.

Timer off setting: press Timer, if LCD won't display xx.x hour, and then it means the timer setting is canceled.

Timer range: 0.5-24hr. Every press of ▲ or ▼ will make the set time increased or decreased by 0.5hr. If either of them is pressed continuously, the set time will increase/ decrease by 0.5hr every 0.5s.

◆ Swing Setting

Swing On: Press Function under on state of the unit to activate the swing function. In this case,  will blink. After that, press Enter/cancel to make a confirmation.

Swing Off: When the Swing function is on, press Function to enter the Swing setting interface, with  blinking. After that, press Enter/cancel to cancel this function.

Note:

k. Sleep, Save, Turbo, Blow or Quiet setting is the same as the Swing setting.

l. After the setting has been done, it has to press the key “Enter/cancel” to back to the setting status or quit automatically five seconds later.

◆ Sleep Setting

Sleep on: Press Function under on state of the unit till the unit enters the Sleep setting interface. After that, press Enter/cancel to confirm the setting.

Sleep off: When the Sleep function is activated, press Function to enter the Sleep setting interface. After that, press Enter/cancel to can this function.

Sleep off is default after power failure and then power recovery, and the sleep functions is unavailable under the fan mode.

Sleep mode

In the Cooling or Dry mode, the temperature will increase by 1°C after the unit runs under Sleep 1 for 1hr and 1°C after another 1hr. After that, the unit will run at this temperature.

In the Heating mode, the temperature will decrease by 1°C after the unit runs under Sleep 1 for 1hr and 1°C after another 1hr. After that, the unit will run at this temperature.

Notes:

a. During the above setting, if Function is pressed down or there is not any operation within 5s, sleep curve setting will be canceled.

b. 26°C is the default Sleep curve temperature before delivery. The wired controller will automatically memorize the Sleep curve after the setting.

◆ Turbo Setting

Turbo function: The unit at the high fan speed can realize quick cooling or heating so that the room temperature can quickly approach the setting value.

In the Cooling or Heating mode, press Function till the unit enters the Turbo setting interface and then press Enter/Cancel to confirm the setting.

When the Turbo function is activated, press Function to enter the Turbo setting interface and then press Enter/Cancel to cancel this function.

Notes:

a. When the Turbo function is activated, if the difference between the room temperature and set temperature is at or below 2°C (detected in successive 1 min.), the Turbo function will be automatically deactivated.

b. Turbo function is unavailable in the Dry and Fan mode. And the Turbo function is off after power failure and then power recovery. If Quiet function is on, Turbo function will be canceled subsequently.

◆ E-heater Setting

E-heater (auxiliary electric heating function): In the Heating mode, E-heater is allowed to be turned on for improvement of efficiency.

Once the wired controller or the remote controller enters the Heating mode, this function will be turned on automatically.

Press Function in the Heating mode to enter the E-heater setting interface and then press Enter/cancel to cancel this function.

Press Function to enter the E-heater setting interface, if the E-heater function is not activated, and then press Enter/Cancel to turn it on.

◆ Blow Setting

Blow function: After the unit is turned off, the water in evaporator of indoor unit will be automatically evaporated to avoid mildew.

In the Cooling or Dry mode, press Function till the unit enters the Blow setting interface and then press Enter/Cancel to active this function.

When the Blow function is activated, press Function to the Blow setting interface and then press Enter/Cancel to cancel this function.

Notes:

a. When the Blow function is activated, if turning off the unit by pressing On/Off or by the remote controller, the indoor fan will run at the low fan speed for 10 min, with "BLOW" displayed on the LCD. While, if the Blow function is deactivated, the indoor fan will be turned off directly.

b. Blow function is unavailable in the Fan or Heating mode.

◆ Other Functions

1) Lock

Upon startup of the unit without malfunction or under the "Off" state of the unit, press ▲ and ▼ at the same time for 5s till the wired controller enters the Lock function. In this case, LCD displays . After that, repress these two buttons at the same time for 5s to quit this function.

Under the Lock state, any other button press won't get any response.

2) Memory

Memory switchover: Under the "Off" state of the unit, press Mode and ▲ at the same time for 5s to switch memory

states between memory on and memory off. When this function is activated, Memory will be displayed. If this function is not set, the unit will be under the “Off” state after power failure and then power recovery.

Memory recovery: If this function has been set for the wired controller, the wired controller after power failure will resume its original running state upon power recovery. Memory contents: On/Off, Mode, set temperature, set fan speed, Save function and Lock function.

3) Enquiry of the Outdoor Ambient Temperature

Under the “On” or “Off” state of the unit, press Enter/Cancel for 5s, and the outdoor ambient temperature will be displayed after a sound of click. This enquiry state will quit by pressing Function or On/Off or during the temperature adjustment. If there is not any operation for 10s, it will also quit automatically.

3.1.4 Errors

If there is an error occurring during the operation of the system, the error code will be displayed on the LCD. If multi errors occur at the same time, their codes will be displayed circularly.

Note: In event of any error, please turn off the unit and contact the professionally skilled personnel.

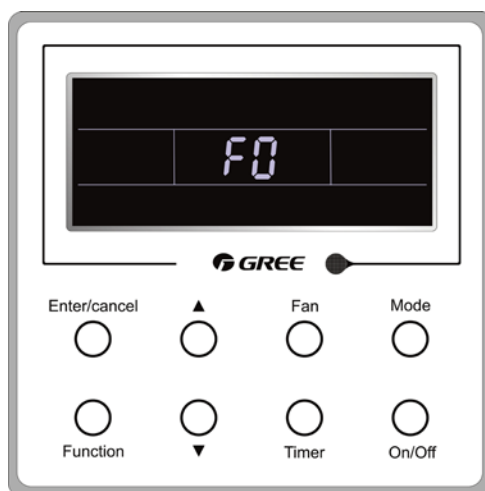

Error	Error Code
High pressure protection	E1
Low pressure protection	E3
Discharge protection	E4
Over-current protection	P5
Communication error	E6
Indoor water overflow protection	E9
Mode conflict	E7
Anti-freezing protection	E2
Defrosting or oil returning for heating	H1
Indoor ambient temperature sensor open/short circuit	F1
Evaporator temperature sensor open/short circuit	F2
Indoor unit (liquid valve) refrigerant pipe inlet temperature sensor error	b5
Indoor unit (gas valve) refrigerant pipe outlet temperature sensor error	b7
Condenser coil inlet temperature sensor open/short circuit	A5
Condenser coil midway temperature sensor error	F4
Condenser coil outlet temperature sensor open/short circuit	A7
Discharge air temperature sensor error	F5
Outdoor ambient temperature sensor error	F3
Module temperature sensor error	oE
Outdoor unit overall error	oE

3.2 Wireless Remote Controller

Wireless Remote Controller YT1F(XFAN)

Notes:

- Be sure that there are no obstructions between the receiver and the remote controller;
- Do not drop or throw the remote controller;
- Do not let any liquid into the remote controller and expose the remote controller to direct sunlight or any place where is very hot.
- This is a general use remote controller. If press some button which is not available for the corresponding function, the unit will keep the original running status.

3.2.1 Function of Press Buttons:



◆ ON/OFF (⏻)

Press this button to turn on/off the unit. After that, the sleep function will be canceled but the preset time is still remained.

◆ MODE

Auto, Cool, Dry Fan, Heat modes can be selected circularly by pressing this button. Auto mode is the default after power on. Under Auto mode, the temperature will not be displayed. Under Heat mode, the initial value is 28°C (82 °F); Under other modes, the initial value is 25°C (77 °F).



- Auto
- Cool
- Dry
- Fan
- Heat (Only for the cooling and heating unit)

◆ SLEEP

Sleep On and Sleep Off can be selected by pressing this button. After powered on, the default is Sleep Off. After the unit is turned off, the Sleep function is canceled. When the sleep function is set already, the symbol will be displayed. And at this time, the time of timer can be adjusted. Under Fan and Auto modes, this unction is not available.

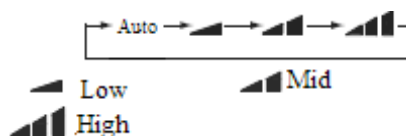

◆ FAN

Auto, Low, Middle, or High fan speed can circularly selected by pressing this button. After powered on, the default is Auto speed. Under Dehumidifying mode, only Low fan speed is available.



◆ CLOCK

The clock can be set up by pressing this button, with the symbol displayed and blinking. In such a case, pressing + or - within 5 seconds can adjust the value. If the button is pressed down for more than 2 seconds, the value on ten's

place will increase by 1 in every 0.5 seconds. After that, repressing this button and then symbol  stops blinking, which indicates the setting is made successfully. After powered on, the default value is 12:00 with  displayed. Once the symbol  is displayed, the current time is the Clock value; otherwise it is the Timer value.

◆ LIGHT

Light On and Light Off can be set by pressing this button when the unit is at On or Off status. After powered on, the default is Light On.

◆ TURBO

In Cool or Heat mode, pressing this button can activate or deactivate this function. When this function is on, its symbol will be displayed. Any change of either mode or fan speed will make this function canceled automatically.

◆ BLOW

BLOW On and BLOW Off can be set by pressing this button. In Cool and Dehumidifying modes, press this button to activate this function and then “BLOW” will be displayed. After that, it can be canceled by repressing this button. After powered on, the default is Blow Off. If the ON/OFF button is operated or the unit is switched to the Cool or Dehumidifying mode, it will keep its original status. When the unit is turned off, Only Blow Off is available. Under Auto, Fan or Heat mode, this function is unavailable.

◆ —

The preset temperature can be decreased by pressing this button. If the button is pressed down for more than 2 seconds, the temperature will be decreased quickly until it is released, with °C (°F) displayed at the time. Under Auto mode, the temperature adjustment is unavailable.

◆ +

The preset temperature can be increased by pressing this button. If the button is pressed down for more than 2 seconds, the temperature will be increased quickly until it is released, with °C (°F) displayed all the time. Under Auto mode, the temperature adjustment is unavailable. The setting range is 16-30 °C or 61-86 °F





◆ TEMP

It can be decided by pressing this button which temperature will be displayed, indoor set temperature, or indoor ambient temperature. When the indoor unit is powered on, the indoor set temperature will be displayed, while if the status is changed to , the indoor ambient temperature will be displayed. However, the indoor set temperature will be displayed again when the controller receives other remote controls signals. Without setting this function, the default is the indoor set temperature.

◆ SWING UP/DOWN ()

The swing angle which circularly changes as below can be selected by pressing this button:



This kind of remoter controller is universal. And the three swing statuses of , ,  are the same as that of .

If the swing function is deactivated when the air guide louver is swing up and down, it will stop at the current position.

 indicates that the air guide louver swings up and down among all five positions.

◆ AIR ()

AIR ON or Air OFF can be selected by pressing this button.

◆ TIMER ON

“ON” will be displayed and blink for 5 seconds by pressing this button, and soon adjust the time by pressing + or — within 5 seconds. Each press will make the time increased or decreased by 1 minute. If the button is pressed down for more than 2 seconds, the time will be changed quickly in such a way: firstly the value on the one’s place is changed and then is the value on the ten’s place. Once Timer ON has been set already, it can be canceled by repressing it. Before the setting, please adjust the CLOCK to the current actual time.

◆ TIMER OFF

TIME OFF can be activated by pressing this button, with “OFF” blinking. The method of setting is the same as that for TIMER ON.

◆ HEALTH ()

This function can be activated or deactivated by pressing this button. After the unit is turned on, the default is HEALTH ON.

◆ I FEEL

This function can be activated by pressing this button and canceled by another press. When this function is on, the I FEEL information will be sent out in 200ms after each operation on the controller and the remote controller will send the temperature information to the main controller every 10 minutes.

3.2.2 Guide for General Operation

- 1) After powered on, press ON/OFF and then the unit will start to run. (Note: when powered off, the guide louver of the main unit will close automatically).
- 2) Press MODE to select the desired running mode.
- 3) Press + or - to set the desired temperature (it is unnecessary to set the temperature under the AUTO mode.)
- 4) Press FAN to set the fan speed, AUTO, LOW, MID, or HIGH.
- 5) Press  to select the swing angle.

3.2.3 Guide for Optional Operation

◆ About BLOW

This function indicates that moisture in the evaporator of the indoor unit will be dried after the unit is stopped to avoid mould.

- a. BLOW ON: When press the ON/OFF button to turn off the unit, the indoor fan will continue running for about another 10 minutes at the low speed. In this case, the indoor fan can be stopped directly by pressing the button BLOW.
- b. BLOW OFF: When press the ON/OFF button to turn off the unit, the whole unit will be stopped completely.

◆ About AFTERHEAT BLOW

Under the Heat mode or Auto Heat mode, if the unit is turned off, the compressor and outdoor fan will stop running immediately and the upper and lower guide board will rotate to the horizontal position, while the indoor fan will still run at the low fan speed. Then, 10 seconds later, the unit will stop completely.

◆ About AUTO RUN

When AUTO RUN is selected, the setting temperature will not be displayed on the LCD and the unit will choose the suitable running mode automatically in accordance with the room temperature.

◆ About TURBO

If this function is activated, the unit will run at super-high fan speed to cool or heat quickly so that the ambient temperature will approaches the preset temperature as soon as possible.



INSTALLATION

INSTALLATION

1 PRECAUTIONS FOR INSTALLATION

1.1 Precautions for Installation

Before installation, please ensure if the installing site, power ratings, possible operating range (pipe distance, height difference between indoor and outdoor unit, power voltage) and installing space are correct and suitable. The outdoor unit is general to all models according to its power.

◆ To ensure correct installation, please make sure to read the Safety Considerations thoroughly before starting the installation works.

◆ The considerations stated below are classified into **⚠WARNING** and **⚠CAUTION**. Those that might cause death or severe injury in case of wrong installation are identified in **⚠WARNING**. However, those that are stated in **⚠CAUTION** may also cause severe accidents sometimes. Therefore, both of them relate to important safety considerations and must be strictly followed..

◆ After completing the installation and test run and confirming that all are normal, please introduce to the client on how to use and repair the machine according to the Operating Instructions. Besides, please deliver the considerations herein to the clients together with the Operating Instructions, and ask them to keep properly.

⚠WARNING!

◆ The installation shall be performed by the vendor or professional dealer from which you buy the machine. If you install by yourself, any improper installation might cause water leakage, electric shock or fire accident.

◆ The installation shall be done correctly according to installation instructions. Improper installation may cause water leakage, electric shock or fire.

◆ To install a large air-conditioning system in a small room, please make sure to take measures to prevent that the refrigerant will not exceed the limit concentration in case of leakage. For the measures to prevent the refrigerant from exceeding the limit concentration, please consult your dealer. If no proper measures, it might cause human suffocation in case of refrigerant leakage.

◆ Please install at a position that is strong enough to support the weight of machine. If the installing position is of low strength, the machine may drop down and thus cause human injury.

◆ Please carry out installation in accordance with the rules for preventing the typhoon or earthquake. The machine may tip over if the installation does not comply with the requirements.

◆ The electrical cabling shall be carried out by qualified electricians in accordance with the Safety Code for Electrical Equipment, relevant local rules and the installation instructions. Make sure to use the special-purpose circuit. If the power circuit capacity is low or the construction is improper, it might cause electric shock or fire accidents.

◆ Please use suitable cables and connect them securely. Please fix the terminal joints securely. The terminal connection shall not be affected due to any external force applied onto the cable. Improper connection and fixing may cause heating and fire accidents.

◆ Keep the cables in correct shape and prevent them from protruding upward. Please protect them securely with repair board. Improper installation may cause heating and fire accidents.

◆ When erecting or relocating the air conditioner, do not let any air enter into cooling circulation system except the specified refrigerant. If any air is mixed, abnormal high pressure will occur in the cooling circulation system, thus causing crack or human injury accidents.

◆ During installation, please always use the attached parts or designated parts. Failure to use the designated parts may cause water leakage, electric shock, fire or refrigerant leakage.

⚠CAUTION:

◆ Please earth securely. Do not connect the earth wires to gas pipe, water pipe, lightning rod or telephone line. Improper earthing might cause electric shock.

◆ Leakage circuit breaker must be installed at some place. No installation of leakage circuit breaker might cause electric shock.

◆ Do not install at a place where inflammable gas might leak. Gas leakage and despot around the machine might cause fire accidents.

◆ To ensure correct drainage of water, the drainage pipe shall be installed according to the installation instructions. Also the heat insulation shall be provided to avoid condensing. Improper installation of the pipe might result in water leakage and lead to possible wetting of the articles in the room.

1.2 Key Points of Installation

Installation Procedures			Description and Acceptance Criteria
Material Selection and Equipment Inspection			<p>The materials specified on the engineering drawing shall be purchased as specified (e.g. copper tube, thermal insulation tube, PVC pipe, power cables, air switch, etc).</p> <p>The materials not specified on the engineering drawing shall be purchased according to the actual quantity of works (e.g. hanger frame, cable duct, etc).</p> <p>Check if the outdoor unit, indoor unit, communication wires and accessories are complete.</p>
Installation of indoor unit	Communication wire	Connection	<p>The power cables shall be separated from communication wires at a least distance of 10cm. To avoid breaking the communication wires, please do not use strong force.</p> <p>For multiple units, please mark them properly.</p> <p>Switch on indoor and outdoor unit, and ensure there is no display of “Communication Wire Error E6”.</p>
		Address dial code	<p>Each indoor unit under the same system has a unique address dial code.</p> <p>The wired controller and its corresponding indoor unit have the same address dial code.</p>
	Remote Control		<p>Select the remote control mode.</p> <p>The centralized controller and communication module shall be installed free from the source of interference.</p>
	Power cord		<p>The power cable must meet the specifications.</p> <p>The indoor units under the same system must be arranged under unified power supply.</p>
	Drainage Pipe	Installation	<p>The PVC pipes must meet the specifications.</p> <p>A specific gradient must be provided along the water flow direction.</p> <p>Carry out water detection after installation.</p> <p>Carry out thermal insulation to the drainage pipe only after the water detection is accepted.</p>
		Thermal insulation	<p>The thermal insulation tube must meet the specifications.</p> <p>Seal between the thermal insulation pipes to avoid air entry.</p>
	Installation of Air Duct (when with high static pressure duct-type unit)		<p>Design the length of air duct according to static pressure;</p> <p>The air inlet shall be optimally designed to avoid too small size</p>
Installation of connection pipes	Welding		<p>The copper tube must meet the specifications.</p> <p>Ensure it is dry and clean inside the tube.</p> <p>Make sure to charge nitrogen as required for protection when welding the tubes.</p> <p>Please keep to the welding process and ensure the system free of leakage.</p> <p>Add a dual-way filter on liquid pipe side</p> <p>For multiple systems, please mark them properly.</p> <p>Carry out leakage detection under pressure after welding.</p>
	Purge and make leakage detection under pressure		<p>Purge the system clean.</p> <p>Keep the pressure for 24 hours</p> <p>Except for the influence by temperature, it is deemed acceptable if pressure drop is within 0.02MPa. (With the temperature change by 1℃, the pressure will change by approx. 0.01MPa)</p>
	Thermal insulation		<p>The thermal insulation tube must meet the specifications.</p> <p>Seal between the thermal insulation pipes to avoid air entry.</p>
Installation of outdoor unit			<p>Select the installing position correctly.</p> <p>Build the foundation according to the anchor bolt position and the dimension of outdoor unit</p> <p>Build the damping device properly.</p> <p>Avoid sharp knock when handling the outdoor unit. The inclination angle shall not be higher than 15°.</p>
Connection of indoor unit and outdoor unit			<p>Tighten the nuts.</p> <p>Provide proper protection to the outdoor connection pipe, communication wires and power supply.</p>
Leakage detection under pressure			<p>Keep the pressure for 24 hours. Except for the influence by temperature, it is deemed acceptable if pressure drop is within 0.02MPa. (With the temperature change by 1℃, the pressure will change by approx. 0.01MPa).</p>
Vacuuming			<p>Establish vacuum simultaneously in the gas pipe and liquid pipe;</p> <p>The vacuuming time shall be long enough.</p> <p>Put still for 1 hour after vacuuming. It is deemed acceptable if the pressure will not rise.</p>
Add refrigerant			<p>Add refrigerant according to the volume as specified on the engineering drawing.</p>
Open the valve of outdoor unit			
Commissioning of complete unit			

Remarks:

- Described above are general working procedures. The procedures might vary with the site conditions.
- For detailed installation rules, please see the description in each chapter.

2 FLOW CHART OF INSTALLATION

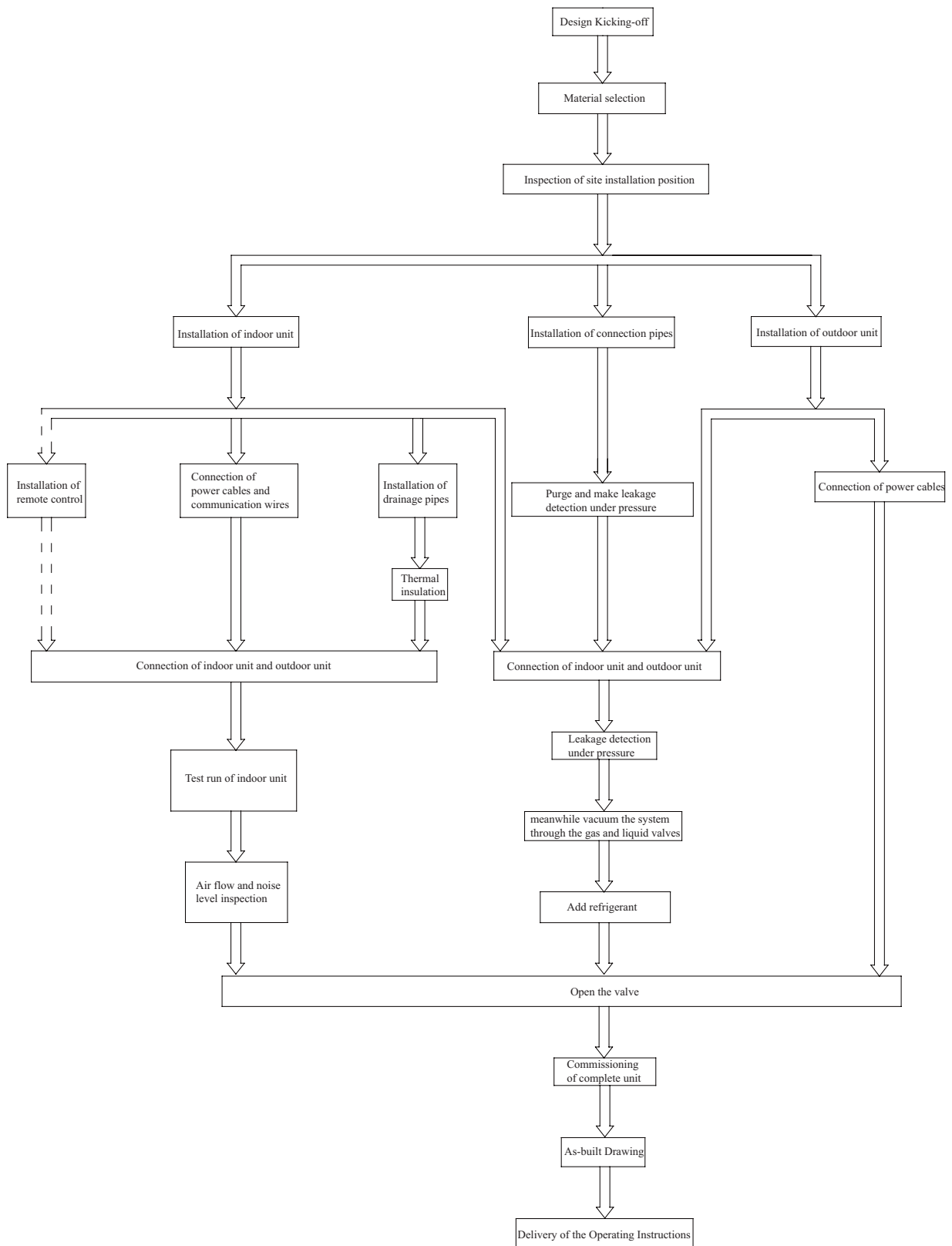

3 OUTDOOR UNIT INSTALLATION

3.1 Before Installation

- ◆ Check if there is any damage to the unit when receive and unpack the unit, and check if the compressor runs reversely, if the grease oil and refrigerant leak, and if all parts are completely prepared. If there is any damage on the surface or the inner side, please inform the shipping company or the equipment manufacturer in the written form promptly.
- ◆ Check if the model, specs and quantity of the unit are consistent with the contact after receive the unit.

3.2 Installation Site

- ◆ The unit may be installed on balcony, roof, special platform or any other position easy to install and able to support the weight.
- ◆ Select the place with good ventilation, where the exhaust is smooth and will not be circulated. Meanwhile, the exhaust from the unit shall not affect the neighbors.
- ◆ The air discharged from the unit will not flow back, and there shall be adequate service space around the machine.
- ◆ Around the unit there shall be no strong heat source or exhaust port of other equipment, nor any strong hot steam or inflammable gas.
- ◆ When several units are to be installed, adequate suction space shall be ensured to avoid short-circuit circulation.
- ◆ Install at a place that will not be affected by rainstorm in winter.
- ◆ Install at a place where there is no obstruction close to the air inlet or outlet.
- ◆ Around the machine body, drainage channel shall be provided for discharge of cold or warm water.
- ◆ The indoor connection pipe is easy to connect outdoors.
- ◆ The indoor and outdoor units shall be installed to minimize the length and bends of refrigerant pipe.
- ◆ Install close to power socket for easy connection of the cables.
- ◆ Open space required around the unit.
- ◆ Fasten the machine onto the supporting legs and base with M12 screw combination.

3.3 Caution for Installation

The following rules should be followed when the installation location is being considered so as to let the unit run well enough.

- ◆ The discharged air from the outdoor unit won't return back and enough space should be left for maintenance around the unit.
- ◆ The installation location should be in good condition so that the unit is able to take in and discharge enough air. Besides, make sure there is no obstacle at the air inlet/outlet of the unit. If there is, remove it.
- ◆ The unit must be installed where it is secure enough to support the weight of the unit and capable of reducing to some extent noise and vibration to make sure they do not bother your neighbors.
- ◆ The designated lifting hole must be used for lifting the unit and protect the unit carefully during lifting to prevent damaging the metal sheet which would result in rusting in future.
- ◆ The unit should be installed where there is as little as direct sunlight.
- ◆ The unit must be installed where the rain water and defrosting water can be drained.
- ◆ The unit must be installed where the unit won't be covered by the snow and won't be affected by rubbish and oil fog.
- ◆ Rubber or spring shock absorbers should be used during the installation of the outdoor unit to meet the noise and vibration requirements.
- ◆ The installation dimensions should meet the requirement covered in this manual and the outdoor unit must be fixed securely.
- ◆ The installation should be carried out by the professionally skilled personnel.

3.4 Dimension Data

The following figure is applicable to the Outdoor units of: GWHD(36)NK3AO

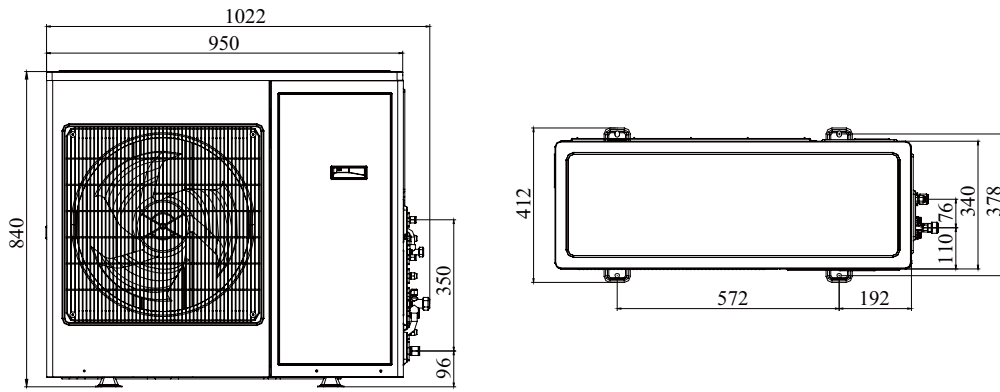

The following figure is applicable to the Outdoor units of: GWHD(42)NK3AO

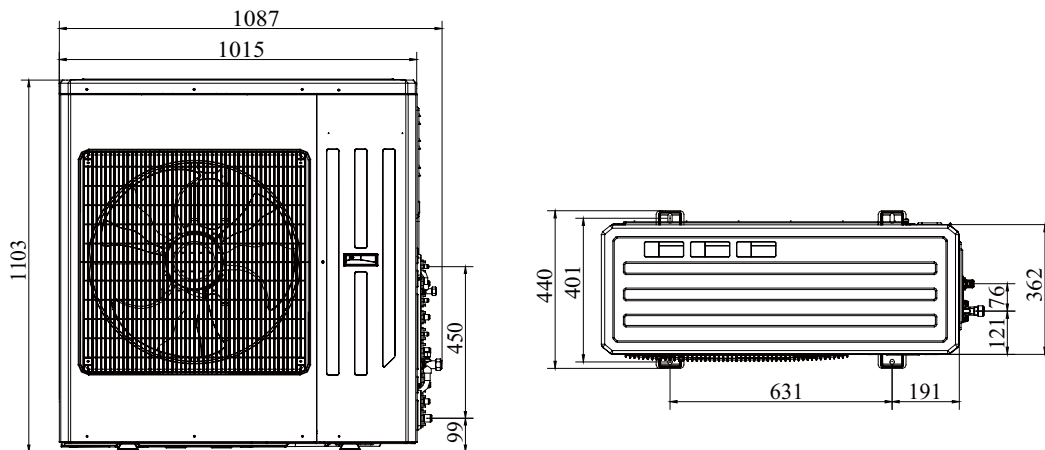

3.5 Installation Clearance Data

Installation Space Requirements of the Outdoor Unit: GWHD(36)NK3AO、GWHD(42)NK3AO

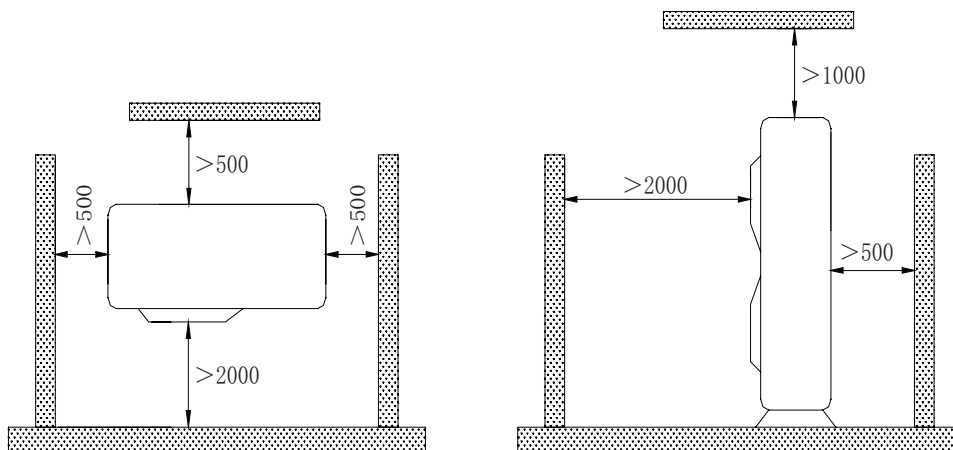

4 INDOOR UNIT INSTALLATION

4.1 Installation of Duct Type

4.1.1 Before Installation

Check if there is any damage to the indoor unit, and the wireless controller and other part and components are prepared completely.

4.1.2 Installation Site

- The selection of the installation place of the air conditioner unit

The installation must accord with the national and local safe criterion.
Since the quality of installation would affect the operation directly, user should contact the seller and have the conditioner installed and tested by the professional install personnel according to the install instruction instead of install by himself/herself.
Only connect the power after all the installation works are finished.

- The selection of the installation place of the indoor unit
- ◆ Prevent direct sun burn.
- ◆ Make sure that the top steeve, ceiling, and the structure of the construction etc. is strong enough to bear the weight of the unit.
- ◆ The drainage pipe is easy to drain.
- ◆ The air flow is not blocked at the outlet and intake vents.
- ◆ The connecting pipe indoor and outdoor can by lead to outside conveniently.
- ◆ The unit cannot be installed in the place where stored the flammability, easy exploded thing or the place where would have leakage of flammability and exploded gas.
- ◆ The unit cannot be installed in the place where has the corrupt gas and serious dust, saline fog, lampblack and huge humidity.

Note:

The air conditioner unit installed in the following place may have malfunction, if the malfunction cannot prevent, please contact the Nominated Repair Center Of Gree Electric Appliances, Inc. Of Zhuhai.

- a. The place with greasy all around;
- b. The seashore place with salinity and alkali;
- c. The place with vulcanized gas(such as vulcanized hot spring);
- d. The place with high frequency equipment (such as wireless equipment, electric welding machine and medical treatment equipment);
- e. The place with special environment.

4.1.3 Caution for Installation

- ◆ Ensure the hanger is strong enough to withstand the weight of the unit.
- ◆ The drainage of the drain pipe is easy.
- ◆ No obstacle is in the inlet/outlet and the air circulation is in good condition.
- ◆ Ensure the installation space is left for the access to maintenance.
- ◆ It should be far away from where there is heat source, leakage of inflammable, explosive substances, or smog.
- ◆ It is the ceiling type unit (concealed in the ceiling).
- ◆ The power cords and connection lines of the indoor and outdoor units must be at least 1m away from the TV set or radio to avoid the image interference and noise (even if 1m is kept, the noise may be produced due to the strong electric wave).

4.1.4 Dimension Data

Note: the unit in the followings figures is mm, unless otherwise specified.

Applicable to GFH(09)EA-K3DNA1A/I,GFH(12)EA-K3DNA1A/I,GFH(18)EA-K3DNA1A/I, GFH(21)EA-K3DNA1A/I, GFH(24)EA-K3DNA1A/I:

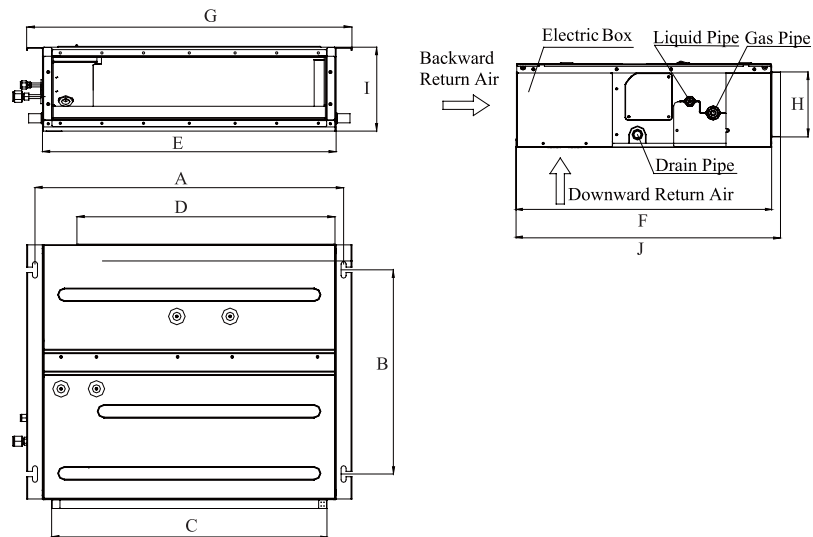
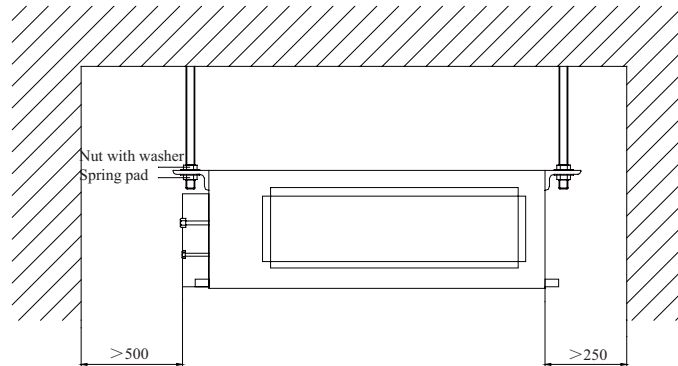

Table Outline Dimensions:

Item	A	B	C	D	E	F	G	H	I	J
Model										
GFH(09)EA-K3DNA1A/I	742	491	662	620	700	615	782	156	200	635
GFH(12)EA-K3DNA1A/I										
GFH(18)EA-K3DNA1A/I	942	491	862	820	900	615	982	156	200	635
GFH(21)EA-K3DNA1A/I	1142	491	1062	1020	1100	615	1182	156	200	635
GFH(24)EA-K3DNA1A/I										

4.1.5 Installation Clearance Data



a. Installation of the Indoor Unit

Insert the M10 expansion bolt into the hole, and then knock the nail into the bolt. Refer to the Outline Dimension Drawings of the Indoor Unit for the distance between holes and see Fig.3 for the installation of the expansion bolt.

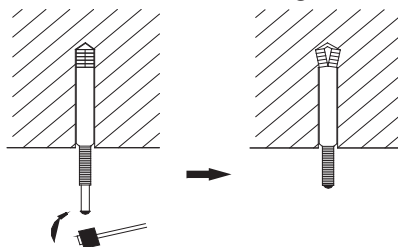

Install the hanger on the indoor unit:

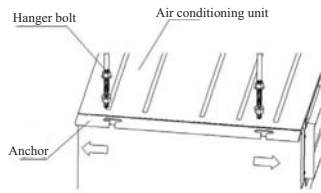

Install the indoor unit on the ceiling:

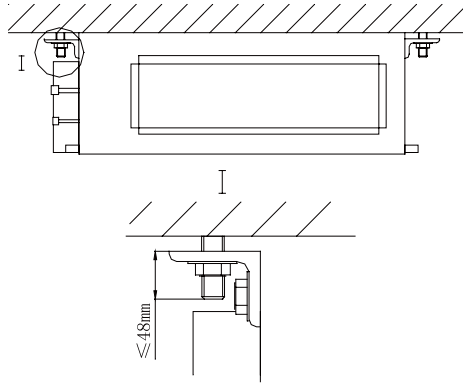

⚠CAUTION:

- a. Prior to the installation, please make a good preparation for all piping (refrigerant pipe, drain pipe) and wiring (wires of the wired controller, wires between the indoor and outdoor unit) of the indoor unit to make the further installation much easier.
- b. If there is an opening in the ceiling, it is better to reinforce it to keep it flat and prevent it vibrating. Consult the user and builder for more details.
- c. If the strength of the ceiling is not strong enough, a beam made of angle iron can be used and then fix the unit on it.
- d. If the indoor unit is not installed in the air conditioning area, please use sponge around the unit to prevent condensing. The thickness of the sponge depends on the actual installation environment.

4.1.6 Horizontality Check of the Indoor Unit

After the installation of the indoor unit, its horizontality must be checked to make sure the unit keep horizontal fore and aft and keep an inclination of 5° toward the drain pipe right and left.

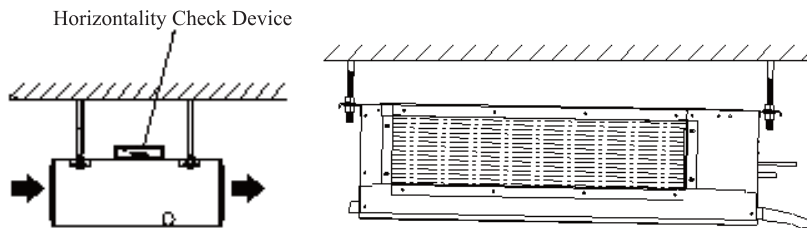
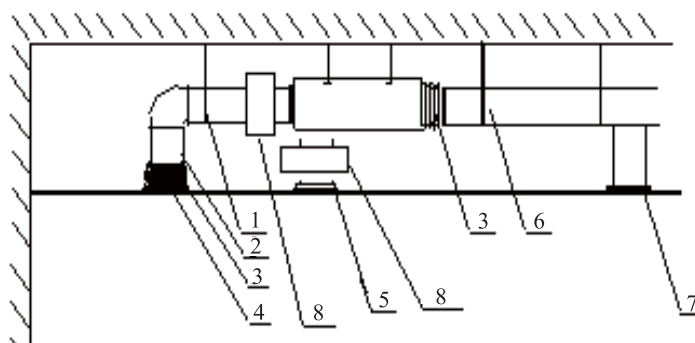

Fig.6

4.1.7 Installation of the Air Supply Duct

- a. Installation of the Rectangular Air Supply Duct



Table

No.	Name	No.	Name
1	Hanger	5	Filter Screen
2	Return Air Duct	6	Main Air Supply Duct
3	Canvas Duct	7	Air Supply Outlet
4	Return Air Inlet	8	Plenum Box

b. Installation of the Round Air Supply Duct

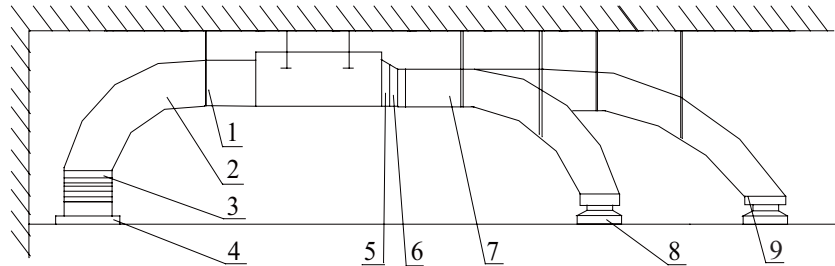

Table

No.	Name	No.	Name
1	Hanger	6	Transition Duct
2	Return Air Duct	7	Air Supply Duct
3	Canvas Duct	8	Diffuser
4	Return Air Louver	9	Diffuser Joint
5	Air Supply Outlet		

c. Installation Steps of the Round Air Supply Duct

- 1) Preinstall the outlet of the round duct on the transition duct and then fix it by the self-tapping screw.
- 2) Place the transition duct to the air outlet of the unit and fix it with rivet.
- 3) Connect the outlet to the duct and then tighten them with tape. Other installation details are not covered herein.

⚠CAUTION:

a. The maximum length of the duct means the maximum length of the air supply duct plus the maximum length of the return air duct.

b. For the unit with the auxiliary electric heating function, if the round duct is to be adopted, then the straight length of the transition duct can not be less than 200mm.

c. The duct is either rectangular or round and connected with the air inlet/outlet of the indoor unit. Among all air supply outlets, at least one should be kept open. As for the round duct, it needs a transition duct of which the size should match with the air supply outlet of the unit. After the fitting of the transition duct, it is the turn of the round duct, which is better to be kept 10 meters far away from the corresponding diffuser. The standard accessories supplied by GREE is the transition duct 200mm long and round air outlet $\phi 200$, however, those of other specifications can be purchased.

4.2 Installation of Cassette Type

4.2.1 Before Installation

Check if there is any damage to the indoor unit, and the wireless controller and other part and components are prepared completely.

4.2.2 Installation Site

Select install location of the indoor unit

- a. Obstruct should put away from the intake or outlet vent of the indoor unit so that the airflow can be blown though all the room.
- b. Make sure that the installation had accord with the requirement of the schematic diagram of installation spaces.
- c. Select the place where can stand 4 times of the weight of the indoor unit and would not increase the operating noise and oscillate.
- d. The horizontally of the installation place should be guaranteed.
- e. Select the place where easy drain condensated coagulated water, and easy connect with outdoor unit.

f. Make sure that there are enough space for care and maintenance. Make sure that the weight between the indoor unit and ground is above 1800mm.

g. When installing the steeve bolt, check if the install place can stand the weight 4 times of the unit's. If not, reinforce before installation. (Refer to the install cardboard and find where should be reinforced)

⚠ Note!

There will be lots of lampblack and dust stick on the acentric, heat exchanger and water pump in dining room and kitchen, which would reduce the capacity of heat exchanger, lead water leakage and abnormal operation of the water pump.

The following treatment should be taken under this circumstance:

a. Ensure that the smoke trap above cooker has enough capacity to obviate lampblack to prevent the indraft of the lampblack by the air conditioner.

b. Keep the air conditioner far from the kitchen so that the lampblack would not be indraft by the air conditioner.

★ Important notice:

◆ To guarantee the good performance, the unit must be installed by professional personnel according with this instruction.

◆ Please contact the local Gree special nominated repair department before installation. Any malfunction caused by the unit that is installed by the department that is not special nominated by GREE would not deal with on time by the inconvenience of the business contact.

4.2.3 Dimension Data

Dimension of ceiling opening and location of the hoisting screw (M10)

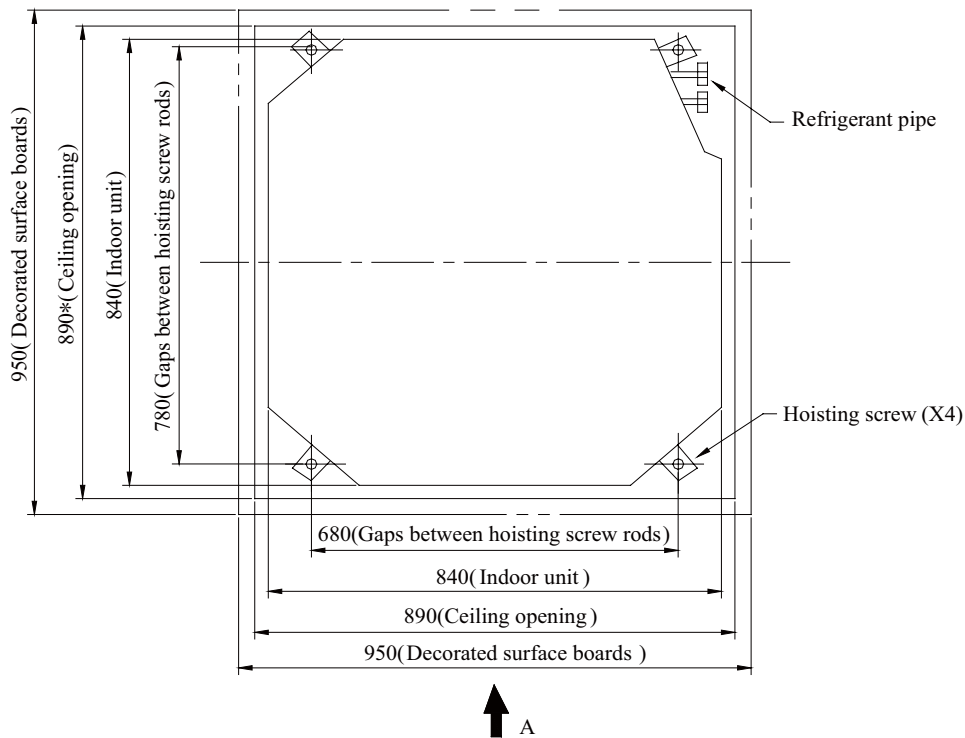

Install dimension of mode

GKH(12)BA-K3DNA1A/I; GKH(18)BA-K3DNA1A/I; GKH(24)BA-K3DNA1A/I

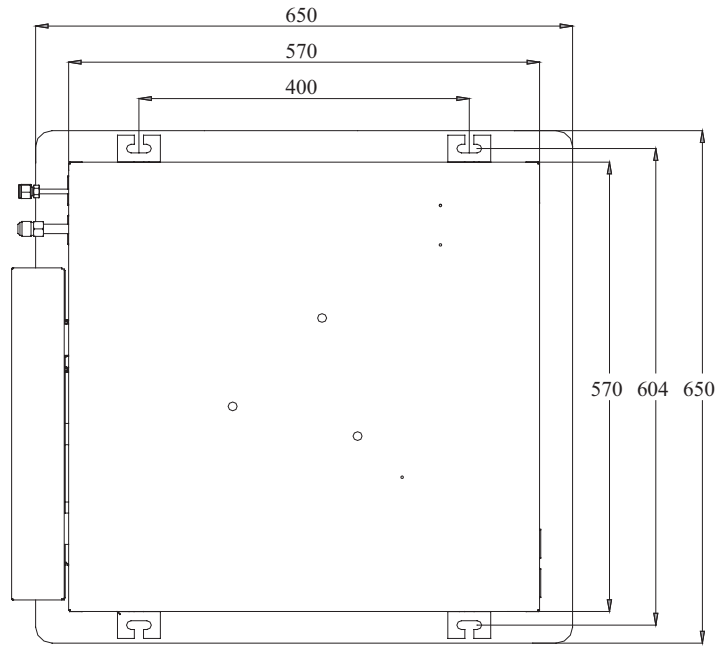

Install dimension of mode GKH(12)BA-K3DNA2A/I;GKH(18)BA-K3DNA2A/I

- ◆ The drilling of holes in the ceiling must be done by the professional personnel.

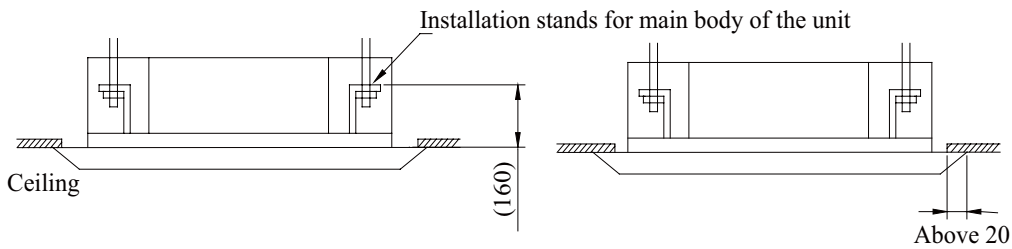

Notes: The dimension for the ceiling openings with * marks can be as large as 910mm. But the overlapping sections of the ceiling and the decorated surface boards should be maintained at no less than 20mm.

2.2.4 Installation Clearance Data

GKH(12)BA-K3DNA1A/I;GKH(18)BA-K3DNA1A/I; GKH(24)BA-K3DNA1A/I

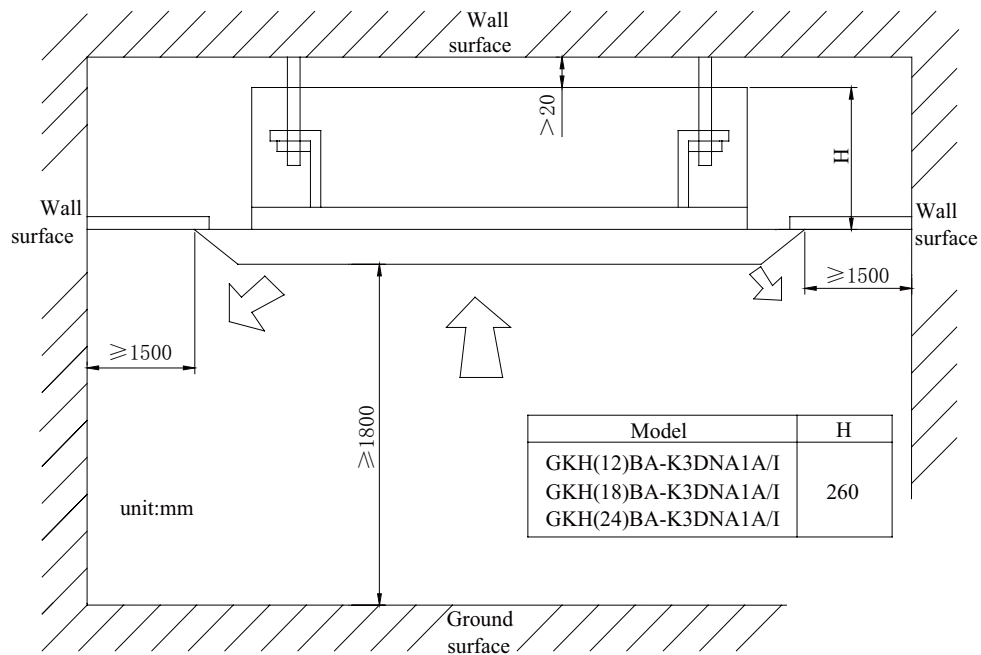

GKH(12)BA-K3DNA2A/I;GKH(18)BA-K3DNA2A/I

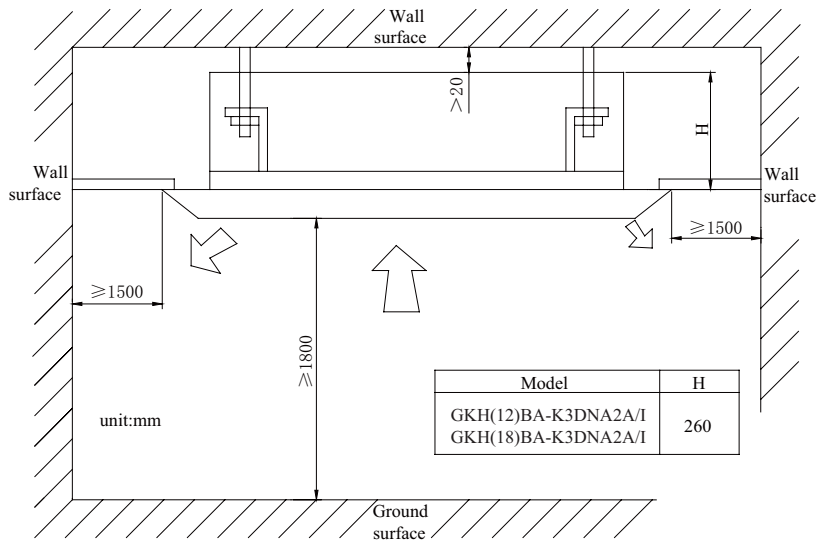

★ Main body of hoisting air conditioner

- The primary step for install the indoor unit.
 - ◆ When attach the hoisting stand on hoisting screw, do use nut and gasket individually at the upper and lower of the hoisting stand to fix it. The use of gasket anchor board can prevent gasket break off.
- Use install cardboard
 - ◆ Please refer to the install cardboard about the dimension of ceiling opening.
 - ◆ The central mark of the ceiling opening is marked on the install cardboard.
 - ◆ Install the install cardboard on the unit by bolt (3 piece), and fix the angle of the drainage pipe at the outlet vent by bolt.
- Adjust the unit to the suitable install place.
- Check if the unit is horizontal.
 - ◆ Inner drainage pump and bobber switch are included in the indoor unit, check if 4 angle of every unit are horizontal by water lever. (If the unit is slant toward the opposite of the coagulate water flow, there may be malfunction of the bobber switch and lead water drop.)
- Backout the gasket anchor board used to prevent gasket break off and tighten the nut on it.
- Backout the install cardboard.

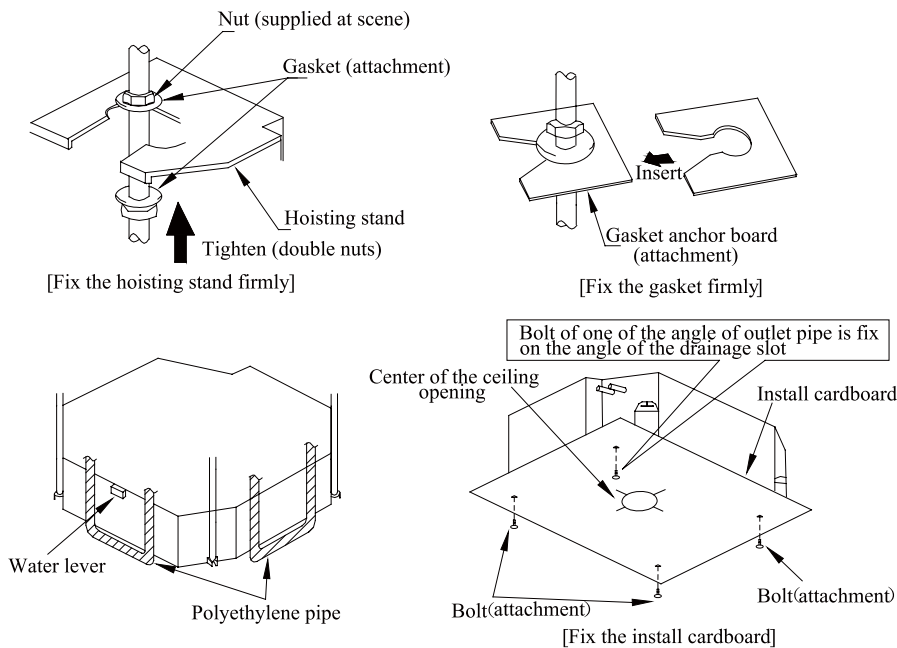

▲ Note!

- Please do tighten the nuts and bolts to prevent air conditioner break off.

★ Connection of the refrigerant pipe

- ◆ When connect the pipe to the unit or backout it from the unit, please do use both spanner and torque wrench.

- ◆ When connect, smear both inside and outside of the flare nut with freeze motor oil, screw it by hand and then tighten it with spanner.
- ◆ Refer to form 1 to check if the wrench had been tightened (too tight would mangle the nut and lead leakage).
- ◆ Examine the connection pipe to see if it had gas leakage, then take the treatment of heat insulation, as shown in the fig.5.
- ◆ Only use median sponge to entwine the wiring interface of the gas pipe and heat preservation sheath of the gas collection tube.

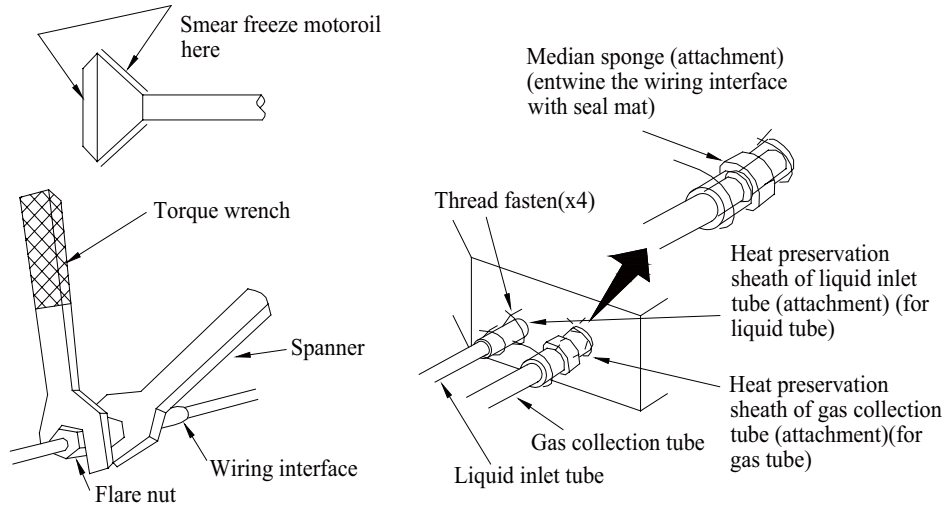

Form 1: The tightening torque needed for tightening nut

Diameter (Inch)	Surface thickness (mm)	Tightening torque (N · m)
φ1/4"	≥ 0.5	15-30 (N · m)
φ3/8"	≥ 0.71	30-40 (N · m)
φ1/2"	≥ 1	45-50 (N · m)
φ5/8"	≥ 1	60-65 (N · m)
φ3/4"	≥ 1	70-75 (N · m)

★ Drainage hose

a. Install the drain hose

- ◆ The diameter of the drain hose should be equal or bigger than the connection pipe's. (The diameter of polythene pipe: Outer diameter 25mm Surface thickness ≥ 1.5mm)
- ◆ Drain hose should be short and drooping gradient should at less 1/100 to prevent the formation of air bubble.
- ◆ If drain hose cannot has enough drooping gradient, drain raising pipe should be added.
- ◆ To prevent bent of the drain hose, the distance between hoisting stand should is 1 to 1.5m.

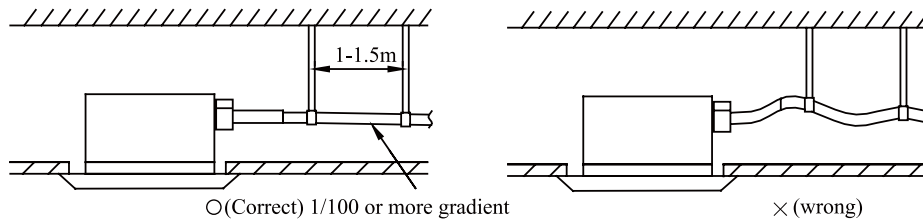

- ◆ Use the drain hose and clamp attached. Insert the drain hose to the drain vent, and then tighten the clamp.
- ◆ Entwine the big sponge on the clamp of drain hose to insulate heat.
- ◆ Heat insulation should be done to indoor drain hose.

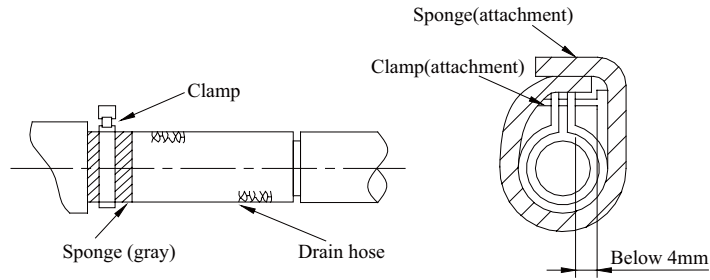

Drain stepup pipe note

- ◆ The install height of the drain raising pipe should less than 280mm.
- ◆ The drain raising pipe should form a right angle with the unit, and distance to unit should not beyond 300mm.

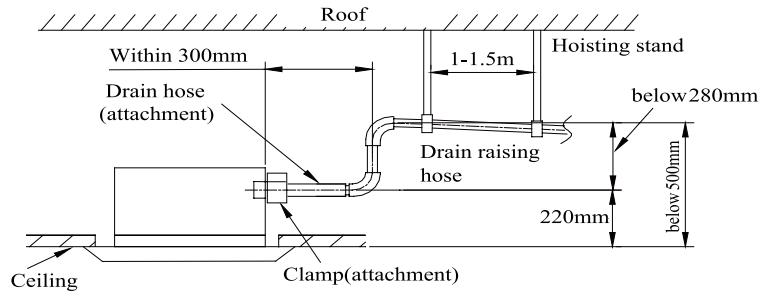

Instruction

- ◆ The slant gradient of the attached drain hose should be within 75mm so that the drain hole doesn't has to endure the unnecessary outside force.

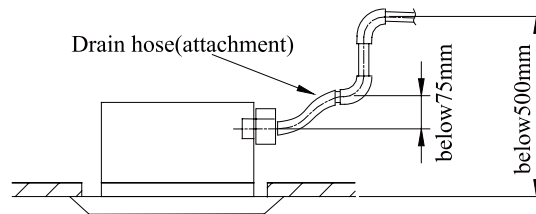

- ◆ Please install the drain hose according to the following process if several drain hoses join together.

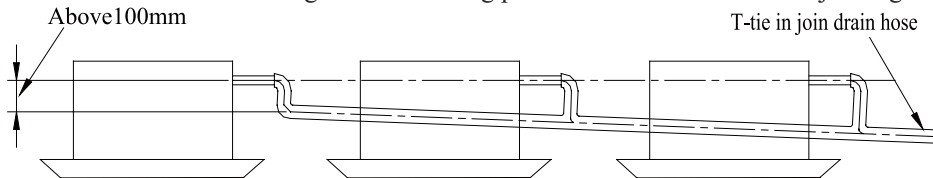

The specs of the selected join drain hose should fits the running capacity of the unit.

b. Check the smoothness of drain after installation.

- ◆ Check the drain state by immiting 600cc water slowly from the outlet vent or test hole.
- ◆ Check the drain in the state of refrigerating after installation of the electric circuit.

[Way of immiting]

Drain vent for repair use (plastic stopper is included) (drain the water in waterspout by this outlet vent)

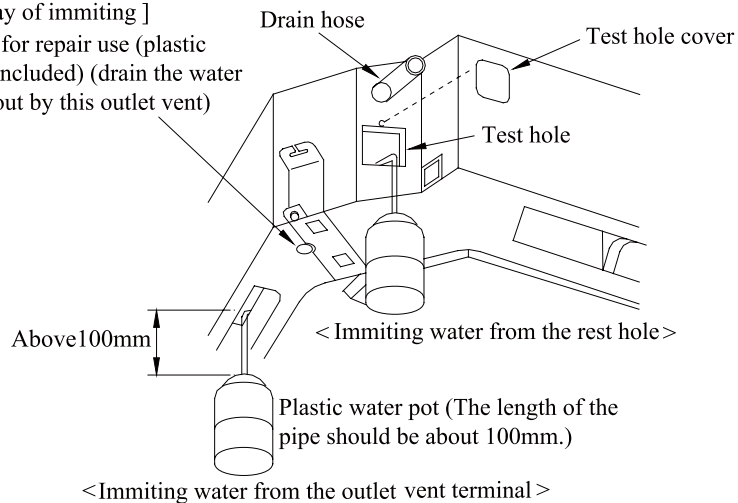

< Immiting water from the outlet vent terminal >

4.3 Installation of Floor Ceiling Type

4.3.1 Before Installation

Check if there is any damage to the indoor unit, and the wireless controller and other part and components are prepared completely.

4.3.2 Installation Site

Selection of Installation Location for Air Conditioner Unit

The installation of air conditioner unit must be in accordance with national and local safety codes. Installation quality will directly affect the normal use of air conditioner unit. The user is prohibited from installation by himself. Please contact your dealer after buying this machine. Professional installation workers will provide installation and test services according to installation manual. Do not connect to power until all installation work is completed.

Selection of Installation Location

- ◆ Such a place where cool air can be distributed throughout the room.
- ◆ Such a place where is condensation water is easily drained out.
- ◆ Such a place that can handle the weight of indoor unit.
- ◆ Such a place, which has easy access for maintenance.
- ◆ Such a place where is permitting easy connection with the outdoor unit.
- ◆ Such a place where is 1m or more away from other electric appliances such as television, audio device, etc.
- ◆ Avoid a location where there is heat source, high humidity or inflammable gas.
- ◆ Do not use the unit in the immediate surroundings of a laundry, a bath, a shower or a swimming pool.
- ◆ Be sure that the installation conforms to the installation dimension diagram.

4.3.3 Dimension Data

When installing the indoor unit, you can refer the paper pattern for installation, and make sure that the drainage side must be 10mm lower than the other side in order to drain the condensation water fluently.

Unit:mm

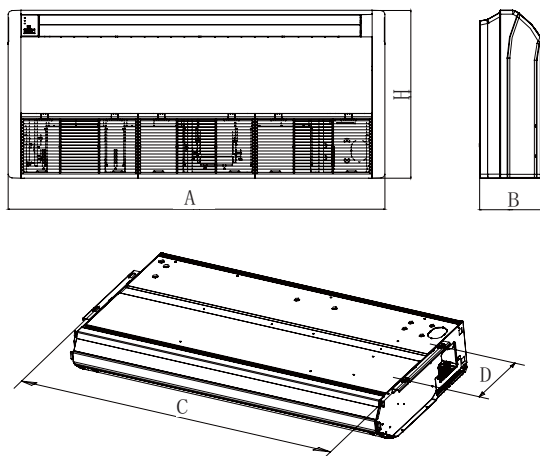

Model	A	B	H	C	D
GTH(09)BA-K3DNA1A/I	1220	225	700	1158	280
GTH(12)BA-K3DNA1A/I					
GTH(18)BA-K3DNA1A/I					
GTH(24)BA-K3DNA1A/I					

4.3.4 Installation Clearance Data

- a. Space dimension for installation of the unit
The space around the unit is adequate for ventilation .

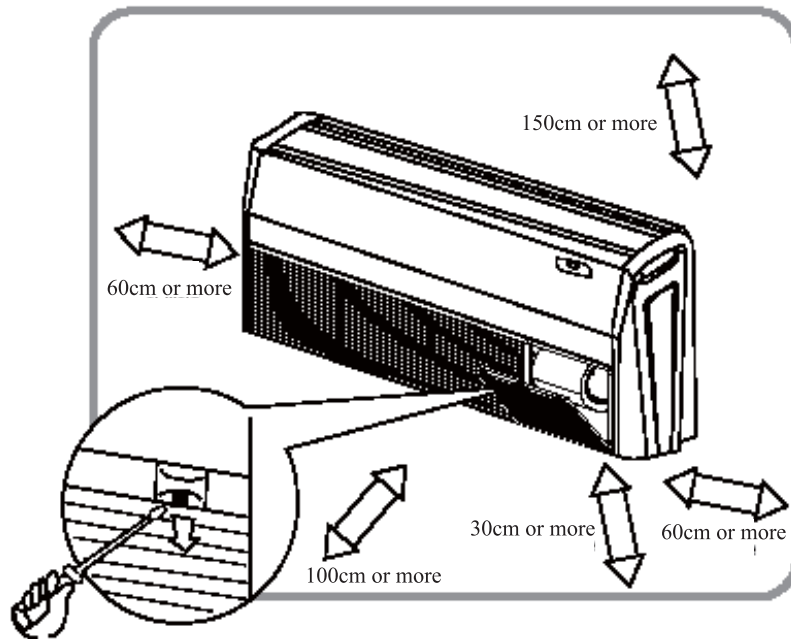

b. Important Notice

◆ The unit must be installed by the professional personnel according to this install instruction to ensure the well use.

Please contact the local Gree special nominated repair department before installation. Any malfunction caused by the unit that is installed by the department that is not special nominated by Gree would not deal with on time by the inconvenience of the business contact.

◆ It should be done by professional personnel when the air conditioner unit is moved to other place.

c. There are 2 styles of installation

* **Ceiling type**

* **Floor type**

1) Each type is similar to the other as follows:

Determine the mounting position on ceiling or wall by using paper pattern to indicate indoor frame. Mark the pattern and pull out the paper pattern. (Refer to ①)

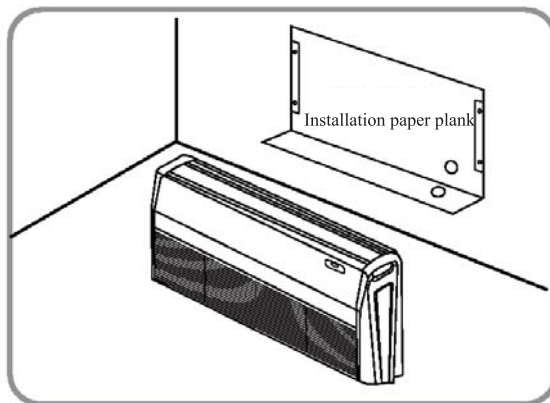

①

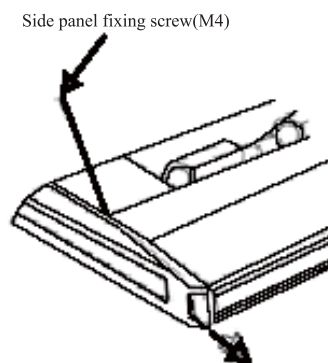

②

2) Remove the return grill, the side panel and the hanger bracket from the indoor unit as per procedure bellow.

◆ Press the fixing knob of the air intake grilles, the grilles will be opened wider and then pull them out from the indoor.

◆ Remove the side panel fixing screw and pull to the front direction (arrow direction) to remove. Side panel fixing screw (Refer to ②).

◆ Loosen two hanger bracket setting bolts (M8) on each side for less than 10mm. Remove two hanger bracket fixing bolts (M6) on the rear side. Detach the hanger bracket by pulling it backward (Refer to ④).

3) Set the suspension bolt. (Use W3/8 or M10 size suspension bolts)

Adjust the distance from the unit to the ceiling slab beforehand (Refer to ③)

4) Fix the hanger bracket to the suspension bolt.

⚠ **Warning !**

◆ Make sure that extended suspension bolt from the ceiling stays inside the arrowed position. Readjust the hanger

bracket when it is outside the arrowed position. (Refer to ⑤)

◆ Suspension bolt stays inside the cap of indoor unit. Never remove the cap.

5) Lift the unit and slide forward unit the dent. (Refer to ⑥)

6) Screw tightly both hanger bracket-setting bolts (M8). (Refer to ④)

7) Screw tightly both hanger bracket-fixing bolts (M6) to prevent the movement of the indoor unit. (Refer to ④)

8) Adjust the height so that rear side of the drainpipe slightly inclines to improve drainage.

⚠ Caution !

◆ Adjust the height by turning the nut with a spanner.

◆ Insert the spanner from the hanger bracket opening. (Refer to ⑦)

In case of hanging

It is possible to install using inward facing hanger brackets by not removing the brackets from the indoor unit. (Refer to ⑧)

Be sure to use only the specified accessories and parts for installation work.

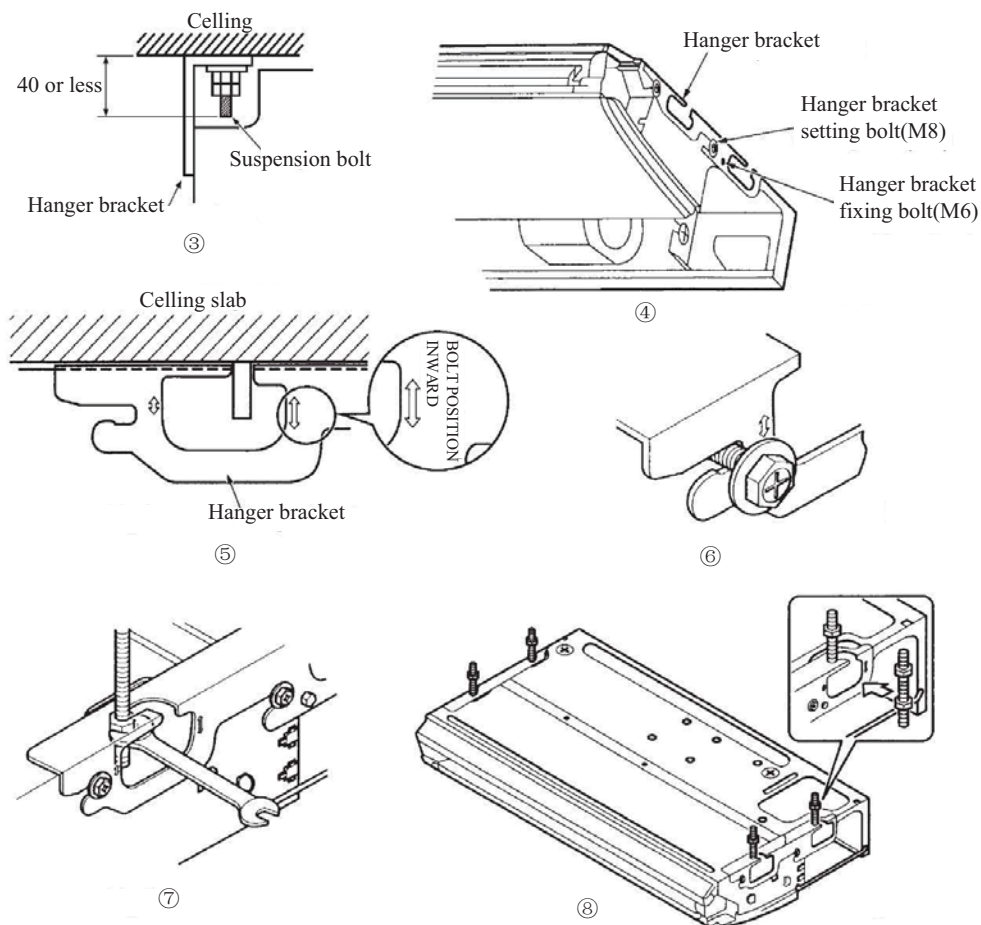

5 REFRIGERATION PIPING WORK

5.1 Connection between Indoor and Outdoor Units

a. Wiring of the Power Cord

⚠ CAUTION !

A breaker must be installed, capable of cutting off the power supply for the whole system.

- 1) Open the side plate.
 - 2) Let the power cord go through the rubber ring.
 - 3) Connect the power card to the terminals “L”, “N” and also the earthing bolt, and then connect the wiring terminals “N(1,2,3)” of the indoor unit to those of the outdoor unit correspondingly.
 - 4) Fix the power cord with wire clips.
- b. Capacity Level and Capacity Code of the Indoor and Outdoor Units

	Capacity Level	Capacity Code
Indoor Unit	09	25
	12	35
	18	50
	21	60
	24	71
Outdoor Unit	36	100
	42	120

◆ One outdoor unit is capable of driving five at maximum and two at minimum indoor units.

◆ Total capacity of the indoor units can be among 50%-150% of that of the outdoor unit.

- 1) The outdoor unit with capacity level 36 can drive up to four sets of indoor units, while the outdoor unit 42 can drive up to five.
- 2) The sum of the capacity codes of the indoor units should be among 50%-150% of that of the outdoor unit.

c. Allowable Length and Height Fall of the Refrigerant Pipe

		Allowable Length		Refrigerant Pipe	
		36	42	36	42
Total Length(m)		70	80	$L_1+L_2+L_3+L_4$	$L_1+L_2+L_3+L_4+L_5$
Max. Length for Single Unit(m)		20	25	L_x	
Max. installation altitude	Outdoor unit and indoor unit	15	15	H1	
	Indoor unit and indoor unit	7.5	7.5	H2	

Dimension of the Refrigerant Pipe of the Indoor Unit

unit:mm

Capacity Level of the Indoor Unit	Gas Pipe	Liquid Pipe
09,12	φ9.52	φ6.35
18	φ12.7	φ6.35
21,24	φ15.9	φ9.52

d. Piping between the Indoor and Outdoor Units

- 1) Refer to Fig.6 for the moments of torque for tightening screws.
- 2) Let the flare end of the copper pipe point at the screw and then tighten the screw by hand.
- 3) After that, tighten the screw by the torque wrench unit it clatters.

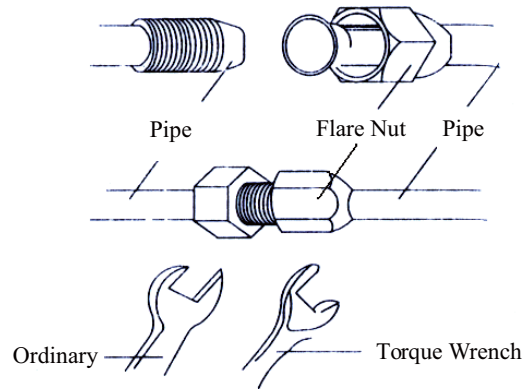

4) The bending degree of the pipe can not be too small; otherwise it will crack. And please use a pipe bender to bend the pipe.

5) Wrap the exposed refrigerant pipe and the joints by sponge and then tighten them with the plastic tape.

Moments of Torque for Tightening Screws

Diameter	Wall Thickness (mm)	Moment of Torque
φ6.35mm	≥ 0.5	15-30 (N·m)
φ9.52mm	≥ 0.71	30-40(N·m)
φ12.7mm	≥ 1	45-50(N·m)
φ15.9mm	≥ 1	60-65(N·m)

⚠CAUTION !

a. During the connection of the indoor unit and the refrigerant pipe, never pull any joints of the indoor unit by force; otherwise the capillary pipe or other pipe may crack, which then would result in leakage.

b. The refrigerant pipe should be supported by brackets, that is, don't let the unit withstand the weight of it.

⚠CAUTION !

For the GMV multi VRF system, each pipe should be labeled to tell which system it belongs to avoid mistaken inaccurate piping.

e. Installation of the Protection Layer of the Refrigerant Pipe

1) The refrigerant pipe should be insulated by the insulating material and plastic tape in order to prevent condensing and leaking.

2) The joints of the indoor unit should be wrapped with the insulating material and no gas is allowed on the joint of the indoor unit.

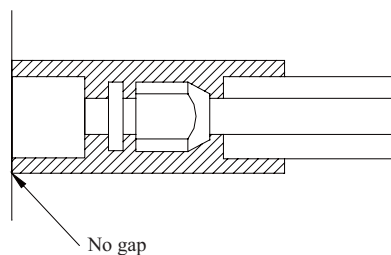

⚠CAUTION !

After the pipe is protected well enough, never bend it to form a small angle; otherwise it would crack or break

f. Wrapping the pipe with tape:

1) Bundle the refrigerant pipe and electric wire together with tape, and separate them from the drain pipe to prevent the condensate water overflowing.

2) Wrap the pipe from the bottom of the outdoor unit to the top of the pipe where it enters the wall. During the wrapping, the later circle should cover half of the former one.

3) Fix the wrapped pipe on the wall with clamps.

⚠CAUTION !

a. Do not wrap the pipe too tightly; otherwise the insulation effect would be weakened. Additionally, make sure the drain hose is separated from the pipe

b. After that, fill the hole on the wall with sealing material to prevent wind and rain coming into the room.

5.2 Refrigerant Charging and Trial Running

a. Refrigerant Charging

- 1) The refrigerant has been charged into the outdoor unit before shipment, while additional refrigerant still need be charged into the refrigerant pipe during the field installation.
- 2) Check if the liquid valve and the gas valve of the outdoor unit are closed fully.
- 3) As shown in the following figure, expel the gas inside the indoor unit and refrigerant pipe out by the vacuum pump.

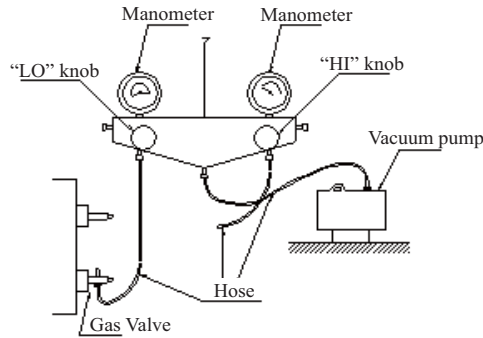

- 4) When the compress is not running, charge the R410A refrigerant into the refrigerant pipe from the liquid valve of the outdoor unit (do not do it from the gas valve)

b. Calculation of the Additional Refrigerant Charge

1) Refrigerant Charge in the Outdoor Unit before Shipment

Model	GWHD(36)NK3AO	GWHD(42)NK3AO
Refrigerant Charge (kg)	3.6	4.8

Notes:

- a. The refrigerant charge mentioned in the table above is not included those charged additionally in the indoor unit and the refrigerant pipe.
- b. The amount of the additional refrigerant charge is dependent on the diameter and length of the liquid refrigerant pipe which is decided by the actual yield installation requirement.
- c. Record the additional refrigerant charge for future maintenance.

2) Calculation of the Additional Refrigerant Charge

If the total refrigerant pipe length (liquid pipe) is smaller than that listed in the table below, no additional refrigerant will be charged.

Model	Total Liquid Pipe Length (a+b+c+d+e)
GWHD(36)NK3AO	≤ 40m
GWHD(42)NK3AO	≤ 50m

Additional Refrigerant Charge₂ = ∑ Extra Liquid Pipe Length × 22g/m (liquid pipe 1/4").

Note: if the total refrigerant pipe length is larger than that listed in the table above, the additional refrigerant for the extra length of the pipe needs to be charged as per 22g/m.

3) Example : GWHD (42) NK3AO

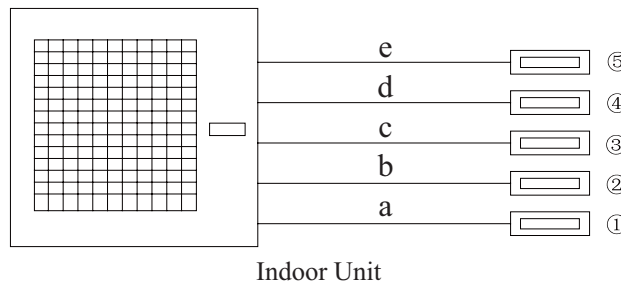

Indoor Unit

Serial No.	Model
Indoor Unit ⑤	Ducted Type GFH(09)EA-K3DNA1A/I
Indoor Unit ④	Ducted Type GFH(09)EA-K3DNA1A/I
Indoor Unit ③	Ducted Type GFH(09)EA-K3DNA1A/I
Indoor Unit ②	Ducted Type GFH(09)EA-K3DNA1A/I
Indoor Unit ①	Ducted Type GFH(18)EA-K3DNA1A/I

Liquid Refrigerant Pipe

Serial No.	e	d	c	b	a
Diameter	φ6.35	φ6.35	φ6.35	φ6.35	φ9.52
Length	20m	20m	15m	5m	5m

The total length of each liquid refrigerant pipe is: $e+d+c+b+a=20+20+15+5+5=65\text{m}$. Thus, the minimum additional refrigerant charge= $(65-50)\times 0.022=0.33\text{kg}$ (Note: no additional refrigerant is needed for the liquid pipe within 50m).

4) Additional Refrigerant Charge Record

Indoor Unit

No.	Indoor Unit Model	Additional Refrigerant Charge(kg)
1		
2		
.....		
N		
Total		

Refrigerant Pipe

Diameter	Total Length(m)	Additional Refrigerant Charge(kg)
Φ15.9		
Φ12.7		
Φ9.52		
Φ6.35		
Total		

c. Items to be checked after the Installation

Items to be Checked	Possible Errors	Check Results
Has each part and component the of unit installed securely?	The unit may fall off, vibrate or generate noise.	
Has the gas leakage test been taken?	The cooling (heating) capacity may be poor.	
Is the thermal insulation sufficient?	Dews and water drops may be generated.	
Does the drainage go well?	Dews and water drops may be generated.	
Is the actual power voltage in line with the value marked on the nameplate?	The unit may break down or some components may be burnt out.	
Are the wiring and the piping correct?	The unit may break down or some components may be burnt out.	
Has the unit been earthed reliably?	There may be a danger of electric shock.	
Does the wire meet the regulated requirement?	The unit may break down or the component may be burnt out.	
Is there any obstacle at the air inlet/outlet of the indoor/outdoor unit?	The cooling (heating) capacity may be poor	
Have the length of the refrigerant pipe and the refrigerant charge been recorded?	It may be hard to know the exact refrigerant charge.	



d. Trial Running

1) Check before the Trial Running

- ◆ Check if the appearance of the unit and the piping system are damaged during the transportation.
- ◆ Check if the wiring terminals of the electronic component are secure.
- ◆ Check if the rotation direction of the fan motor is right.
- ◆ Check if all valves in the system are fully opened.

2) Trial Running

◆ The trial running should be carried out by the professionally skilled personnel on the premise that all items listed above are in normal conditions.

- ◆ Let the unit energized and switch the wired controller or the remoter controller to “ON”.
- ◆ The fan motor and compressor of the outdoor unit will run automatically in one minute.
- ◆ If there is some unusual sound after the compressor is started, turn off the unit for an immediate check.

6 ELECTRIC WIRING WORK

6.1 Wiring Principle

6.1.1 Itemized Description of Cautions.

The electrical installation must be done by professional electricians.

The electrical installation must be done in accordance with applicable technical codes and other rules.

⚠ WARNING!

Please make sure to install earth leakage circuit breaker. Earth leakage circuit breaker must be installed to prevent electric shock or fire.

CAUTIONS!

The air conditioner must be securely earthed. Incorrect earthing may cause electric shock or fire.

◆ All the electric installations must be carried out by specialist technicians in accordance with the local laws, rules and these instructions.

◆ The indoor unit and outdoor unit shall use different power supplies. The indoor units under the same system must be powered by a unified power source. All the indoor units can only be controlled by one master power switch. Rated supply voltage and special circuit for air conditioner must be used.

◆ The earthing shall be secure. The earthing wire shall be connected to the special earthing device on the construction. The installation must be done by specialist technicians. Never connect the earth lead to the gas pipe, water pipe, lightning rod or telephone earth wire.

◆ To avoid electric shock or any accident due to mal-operation, the air switch and shock-resistant earth leakage circuit breaker that can cut off the power supply of the complete system must be installed. The air switch shall have both the magnetic tripping and thermal tripping functions to ensure protection against the short circuit and overload. Electric shock or fire might be caused if no installation of earth leakage circuit breaker. Do not switch on the power before completion of the electrical work. Make sure to cut off the power supply before repair.

◆ Under no condition could use the capacitor to improve the power factor.

◆ Please use cable conduit for power cords.

◆ Do not lay the electronic control cables (remote control and signal line) outside the machine with other cables; otherwise the machine might become malfunctioned or failed due to electrical noise.

◆ The power cord must be always connected to the power cord terminal board, and fixed by using the lock connector included with the machine. Meanwhile, prevent them from contacting the fitting pipe. The diameter of power cords shall be large enough. See below for the detailed specifications. The damaged power cords and connection lines must be replaced with the designated cables. When connecting the cable, please confirm that all the electrical components inside the electric box shall have no coupling or terminal loosened. (Improper installation of electric box cover may lead to potential water leakage, which will cause the unit abnormal or short circuit).

◆ Earth lead must be connected before connecting the power cord. An earth lead longer than the power cord shall be provided.

◆ For site wiring, please refer to the circuit diagram attached on the machine body.

6.1.2 Earthing Requirements

1) The air conditioner is classified into the Class I appliances, so its earthing must be reliable.

2) The yellow-green line of the air conditioner is the earth line and can not be used for other purpose, cut off or fixed by the self-tapping screw; otherwise it would cause the hazard of electric shock.

3) The reliable earth terminal should be provided and the earth wire can not be connected to any of the following places.

① Running water pipe;

② Coal gas pipe;

③ Sewage pipe;

④ Other places where the professional personnel think unreliable

6.2 Electric Wiring Design

⚠ Caution: The power of every indoor unit should be connected in outdoor unit.

a. Open surface panel.

b. Remove the electrical box cover.

c. Route the power connection cord from the back of the indoor unit and pull it toward the front through the wiring hole upward.

d. Connect the wiring (communication) through the piping hole of the chassis and the bottom of the appliance upward, then connect the brown wire to the Terminal board "3";black wire(the communication wire) to the Terminal board"2";blue wire to the Terminal board"N(1)",and connect the earthing wire to the screw terminal on the electric box.

Clamp them with the corresponding wire clamp packed in the chassis;

- e. Reassemble the electrical box cover.
- f. Recover the surface panel.
- g. The temperature of refrigerant circuit will be high, please keep the interconnection cable away from the copper tube.

GWHD(36)NK3AO

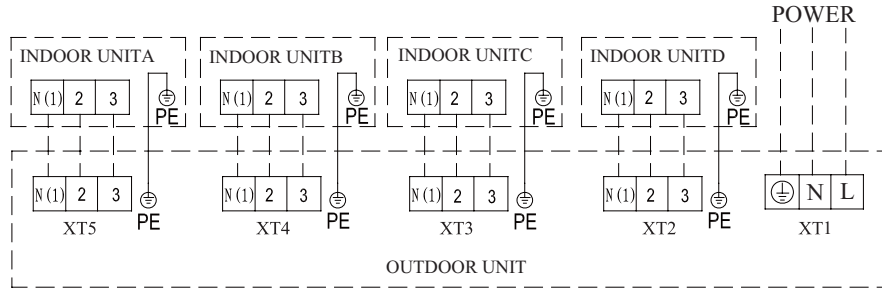

GWHD(42)NK3AO

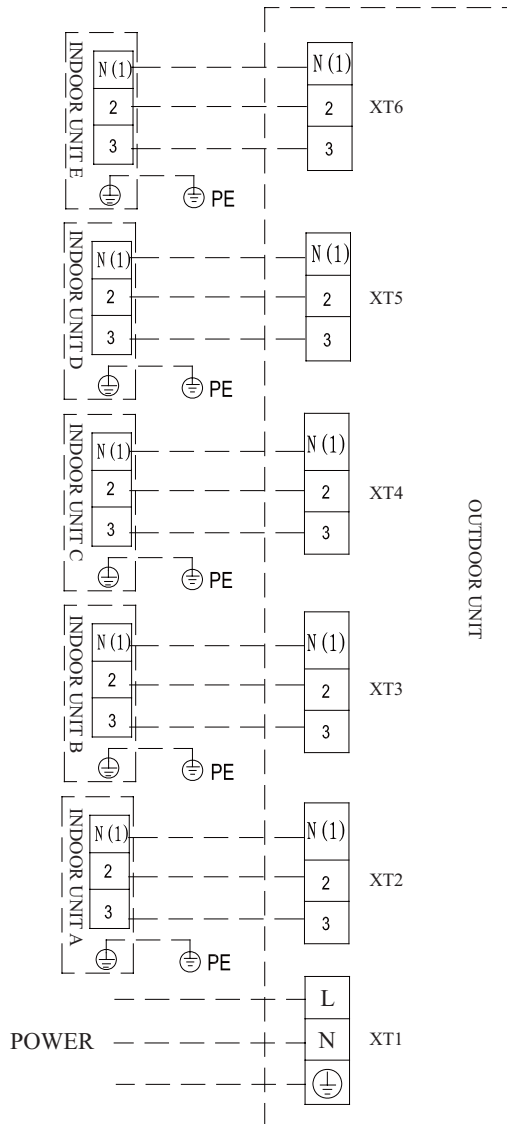

⚠ Caution !

- a. The incorrect of wiring connecting would lead malfunction of some of the electric elements.
- b. Make sure that the lead between the connect end and the clamp end has some need space after the wire is fixed.
- c. The appliance shall be installed in accordance with national wiring regulations.

Noise Precautions

- 1) The air conditioning unit should be installed where ventilation is in good condition, otherwise the working capability of the unit would be reduced or working noise would be increased.
- 2) The air conditioning unit should be installed on the base frame which is stable and secure enough to withstand the weight of the unit; otherwise it would incur vibration and noise.
- 3) During the installation, a consideration should be taken that the produced hot air or noise should not affect neighbors and surroundings.
- 4) Do not stack obstacles near the air outlet of the outdoor unit; otherwise it would reduce the working capability of the unit or increase the working noise.
- 5) In the event of the occurrence of abnormal noise, please contact the sales agent as soon as possible.

Accessories for Installation

Refer to the packing list for the accessories of the indoor and outdoor units respectively.

6.3 Specification of Power Supply Wire and Air Switch

- 1) The installation must be done in accordance with the national wiring regulations.
- 2) Only the power cord with the rated voltage and exclusive circuit for the air conditioning can be used.
- 3) Do not pull the power cord by force.
- 4) The electric installation should be carried out by the professional personnel as instructed by the local laws, regulations and also this manual.
- 5) The diameter of the power cord should be large enough and once it is damaged it must be replaced by the dedicated one.
- 6) The earthing should be reliable and the earth wire should be connected to the dedicated device of the building by the professional personnel. Besides, the air switch coupled with the leakage current protection switch must be equipped, which is of enough capacity and of both magnetic and thermal tripping functions in case of the short circuit and overload.

Models	Power Supply	Capacity of the Air Switch	Recommended Cord (pieces× sectional area)
GWHD(36)NK3AO	220-240V~ 50Hz	32A	6mm ² ×3
GWHD(42)NK3AO	220-240V~ 50Hz	32A	6mm ² ×3



MAINTENANCE

MAINTENANCE

1 TROUBLE TABLE

WARNING !

a. In the event of abnormal conditions (like, stinky smell), please shut off the main power supply immediately and then contact the GREE appointed service center; otherwise the continuous abnormal running would damage the air conditioning unit and also would cause electric shock or fire hazard etc.

b. Do not repair the air conditioning personally but instead contact the professionally skilled personnel at the GREE appointed service center, as the incorrect repair would cause electric shock or fire hazard etc.

1.1 Please check the following items before contact the maintenance serviceman

Conditions	Causes	Corrective Actions
The unit does not run	Broken fuse or opened breaker	Change the fuse or close the breaker
	Power off	Restart the unit when power on
	Loosened power supply plug.	Plug the power supply properly.
	Insufficient batteries voltage of the remote controller	Change new batteries
	Remoter controller out of the control scope	Keep the control distance within 8 meters.
The unit stops soon after it starts	Clogged inlet/outlet of the indoor/outdoor unit	Clear the obstacle
Cooling/Heating is abnormal	Clogged inlet/outlet of the indoor/outdoor unit	Clear the obstacle
	Improperly set temperature	Adjust the setting of the remote or wired controller.
	Too low set fan speed	Adjust the setting of the remote or wired controller.
	Incorrect air direction	Adjust the setting of the remote or wired controller.
	Opened door and window	Close the door and window
	Direct sunlight	Hang a curtain or blinds over the window.
	Too much people in the room	
	Too much heat sources in the room	Reduce the heat sources
	Dirty filter screen	Clean the filter screen

Note:

If the air conditioner still runs abnormally after the above check and handling, please contact the maintenance serviceman at the local appointed service center and also give a description of the error occurred as well as the model of the unit

1.2 The conditions listed below are not classified into errors

Conditions	Causes	
The unit does not run	When restart the unit soon after it is stopped.	The overload protection switch of the unit let the startup delayed for three minutes.
	As soon as power is on.	The unit will stand by for approximate one minute.
The unit blows out mist	When the cooling operation starts.	The hi-humidity air indoor is cooled quickly.
The unit generates noise	The unit "clatters" as soon as it starts running.	It is the sound generated during the initialization of the electronic expansion valve.
	The unit "swishes" during the cooling operation.	It the sound when the refrigerant gas runs inside the unit.
	The unit "swishes" when it is started or stopped.	It is the sound when the refrigerant gas stops running.
	The unit "swishes" when in it is and after the running.	It is the sound when the draining system is operating.
	The unit "squeaks" when it is in and after the running.	It is the sound of friction generated by the skin plate etc which swells due to the temperature change.
The unit blows out dust.	When the unit restarts after it is not used for a long time.	The dust inside the unit is blown out again.
The unit emits odors.	When the unit is running.	The odors absorbed in are blown out again.

1.3 Error description

If some error occurs when the unit is running, the error code will be displayed on the wired controller and the main board  of the outdoor unit. See the table below for more details about the meaning of each error.

Residential AC Errors	Commerical AC Errors	Outdoor Unit "88" Display	Indicating Lamp			Lamp Panel "88" Display (Floor Ceiling Type)	Wired Controller Display
			Running	Cooling	Heating		
/	Defrosting mode 1	08	/	/	/	/	/
/	Defrosting mode 2	0A	/	/	/	/	/
/	heating overload protection	0C	Flash 3 times	Flash 3 times	Flash 3 times	/	oE
/	Normal running	ON	/	/	/	/	/
Short/open circuit of the liquid valve temperature sensor	Short/open circuit of the liquid valve temperature sensor	Shown as Table 16	/	Flash 19 times	/	b5	b5
Short/open circuit of the gas valve temperature sensor	Short/open circuit of the gas valve temperature sensor	Shown as Table 16	/	Flash 22 times	/	b7	b7
Refrigerant insufficiency or blockage protection (available for the residential outdoor unit)	Refrigerant insufficiency or blockage protection (available for the residential outdoor unit)	F0	/	Flash 10 times	/	oE	oE
Short/open circuit of the indoor ambient temperature sensor	Short/open circuit of the indoor ambient temperature sensor	Shown as Table 16	/	Flash once	/	F1	F1
Short/open circuit of the indoor evaporator	Short/open circuit of the indoor evaporator	Shown as Table 16	/	Flash twice	/	F2	F2
Short/open circuit of the outdoor ambient temperature sensor	Short/open circuit of the outdoor ambient temperature sensor	F3	/	Flash 3 times	/	F3	F3
Short/open circuit of the temperature sensor at the midway of the condenser coil (for the commercial unit)	Short/open circuit of the temperature sensor at the midway of the condenser coil (for the commercial unit)	F4	/	Flash 4 times	/	F4	F4
Short/open circuit of the outdoor discharge temperature sensor	Short/open circuit of the outdoor discharge temperature sensor	F5	/	Flash 5 times	/	F5	F5
Oil returning in cooling	Oil returning in cooling	F7	/	/	/	/	/
System high pressure protection	System high pressure protection	E1	Flash once	/	/	E1	E1
Anti-freezing protection	Anti-freezing protection	E2	Flash twice	/	/	E2	E2
System low pressure protection (reserved)	System low pressure protection	E3	Flash 3 times	/	/	E3	E3
Compressor discharge high temperature protection	Compressor discharge high temperature protection	E4	Flash 4 times	/	/	E4	E4
Whole unit over-current protection	Whole unit over-current protection	E5	Flash 3 times	Flash 3 times	Flash 3 times	oE	oE
Communication error between the indoor and outdoor units	Communication error between the indoor and outdoor units	Shown as Table 16	Flash 6 times	/	/	E6	E6
Mode conflict	Mode conflict	Shown as Table 16	Flash 7 times	/	/	E7	E7
Overload protection	Overload protection	E8	Flash 3 times	Flash 3 times	Flash 3 times	oE	oE
Anti cold blow protection	/	E9	/	/	/	/	/
/	Indoor unit water overflow error		/	Flash	Flash	E9	E9
Trial run/trial operation	Trial run/trial operation	dd	Quick flash	Quick flash	Quick flash	dd	dd
Refrigerant recovery mode	Refrigerant recovery mode	Fo	Quick flash	Quick flash	/	Fo	Fo
Drive module resetting (for the commercial unit)	IPM Drive module resetting	P0	Flash 3 times	Flash 3 times	Flash 3 times	oE	oE

Min. cooling/heating (capability test code)	Cooling IPLV test	P0	/	Quick flash	/	P0	P0
	Cooling IPLV test		/	/	Quick flash	P0	
Mid. Cooling/heating (capability test code)	Cooling level AA performance test	P3	/	Quick flash	/	P3	P3
	Level AA cooling performance test		/	/	Quick flash	P3	
Phase over-current protection	Compressor over-current protection	P5	Flash 3 times	Flash 3 times	Flash 3 times	oE	oE
Drive board communication error(for the commercial unit)	Communication error between the inverter driver to the main controller	P6	Flash 3 times	Flash 3 times	Flash 3 times	oE	oE
Short/open circuit of the of the module temperature sensor	Short/open circuit of the of the module temperature sensor	P7	Flash 3 times	Flash 3 times	Flash 3 times	oE	oE
Module temperature protection	Module temperature protection	P8	Flash 3 times	Flash 3 times	Flash 3 times	oE	oE
AC contact protection (for the commercial unit)	AC contact protection	P9	Flash 3 times	Flash 3 times	Flash 3 times	oE	oE
Circuit sensor error	Circuit sensor error	Pc	Flash 3 times	Flash 3 times	Flash 3 times	oE	oE
Transducer connection protection (for the commercial unit)	Transducer connection protection	Pd	Flash 3 times	Flash 3 times	Flash 3 times	oE	oE
AC current protection(input side)	AC current protection(input side)	PA	Flash 3 times	Flash 3 times	Flash 3 times	oE	oE
Temperature drift protection (for the commercial unit)	Temperature drift protection	PE	Flash 3 times	Flash 3 times	Flash 3 times	oE	oE
Drive board ambient temperature sensor error (for the commercial unit)	Drive board ambient temperature sensor error	PF	Flash 3 times	Flash 3 times	Flash 3 times	oE	oE
DC link high voltage protection	DC link low voltage protection	PL	Flash 3 times	Flash 3 times	Flash 3 times	oE	oE
DC link low voltage protection	DC link high voltage protection	PH	Flash 3 times	Flash 3 times	Flash 3 times	oE	oE
/	Abnormal AC input voltage	PP	Flash 3 times	Flash 3 times	Flash 3 times	oE	oE
Capacitor charging error	Capacitor charging error	PU	Flash 3 times	Flash 3 times	Flash 3 times	oE	oE
Jumper terminal error protection	Jumper terminal error protection	C5	Flash 3 times	Flash 3 times	Flash 3 times	oE	oE
Defrosting or oil returning in heating	Defrosting or oil returning in heating	H1	/	/	Flash once	H1	Defrosting symbol displayed
/	Forcible defrosting	H1	Quick flash	/	/	H1	H1
Compressor thermal overload protection.	Compressor overload protection.	H3	Flash 3 times	Flash 3 times	Flash 3 times	oE	oE
Modulecurrent protection (namely IPM protection)	IPM Module current protection	H5	Flash 3 times	Flash 3 times	Flash 3 times	oE	oE
Compressor desynchronizing	Compressor desynchronizing	H7	Flash 3 times	Flash 3 times	Flash 3 times	oE	oE
PFC Protection	PFC Protection	HC	Flash 3 times	Flash 3 times	Flash 3 times	oE	oE
Too high power protection (available for the residential outdoor unit)	Too high power protection (available for the residential outdoor unit)	L9	Flash 20 times	/	/	oE	oE
Compressor startup failure	Compressor startup failure	Lc	Flash 3 times	Flash 3 times	Flash 3 times	oE	oE
Compressor phase failure/reverse protection	Compressor phase failure/reverse protection	Ld	Flash 3 times	Flash 3 times	Flash 3 times	oE	oE
Compressor rotation failure(for the commercial unit)	Compressor rotation failure(for the commercial unit)	LE	Flash 3 times	Flash 3 times	Flash 3 times	oE	oE
Over speed (for the commercial unit)	Over speed	LF	Flash 3 times	Flash 3 times	Flash 3 times	oE	oE

Short/open circuit of the temperature sensor at the inlet of the condenser coil (for the commercial unit)	/	A5	/	/	/	/	/
Short/open circuit of the temperature sensor at the outlet of the condenser coil (for the commercial unit)	/	A7	/	/	/	/	/
Memory card error	/	EE	/	/	/	/	/
Frequency limitation/ degradation for module circuit protection (for phase circuit)	/	En	/	/	/	/	/
Frequency limitation/ degradation for module temperature protection	/	EU	/	/	/	/	/
Frequency limitation/ degradation for overload	/	F6	/	Flash 6 times	/	/	/
Frequency limitation / degradation for circuit protection of the whole unit	/	F8	/	Flash 8 times	/	/	/
Frequency limitation/ degradation for module circuit protection (for phase circuit)	/	F9	/	Flash 9 times	/	/	/
Frequency limitation/ degradation for anti-freezing protection	/	FH	/	Flash 2 times	Flash 2 times	/	/
No indoor fan motor	/	H6	Flash 11 times	/	/	/	/
Compressor demagnetizing protection	/	HE	/	/	Flash 14 times	/	/
Indoor and outdoor units unmatched	/	LP	Flash 19 times	/	/	/	/
Compressor phase circuit detection error	/	U1	/	/	Flash 12 times	/	/
DC link voltage drop error	/	U3	/	/	Flash 20 times	/	/
Zero detection circuit error	/	U8	Flash 17 times	/	/	/	/
Nominal cooling/heating (capability test code)	/	P1	/	/	/	/	/
Max. cooling/heating (capability test code)	/	P2	/	/	/	/	/

The words in gray means the corresponding function is unavailable.

Error Code	Error Description	Error Code	Error Description	Error Code	Error Description
13	Unit A indoor unit pipe outlet temperature sensor error	23	Unit B indoor unit pipe outlet temperature sensor error	33	Unit C indoor unit pipe outlet temperature sensor error
14	Unit A indoor pipe inlet temperature sensor error	24	Unit B indoor pipe inlet temperature sensor error	34	Unit C indoor pipe inlet temperature sensor error
15	Unit A indoor ambient temperature sensor error	25	Unit B indoor ambient temperature sensor error	35	Unit C indoor ambient temperature sensor error
16	Unit A mode conflict	26	Unit B mode conflict	36	Unit C mode conflict
17	Unit A anti-freezing protection	27	Unit B anti-freezing protection	37	Unit C anti-freezing protection
41	Unit D communication error	46	Unit D mode conflict	54	Unit E indoor pipe inlet temperature sensor error
42	Unit D indoor pipe midway temperature sensor error	47	Unit D anti-freezing protection	55	Unit E indoor ambient temperature sensor error

43	Unit D indoor unit pipe outlet temperature sensor error	51	Unit E communication error	56	Unit E mode conflict
44	Unit D indoor pipe inlet temperature sensor error	52	Unit E indoor pipe midway temperature sensor error	57	Unit E anti-freezing protection
45	Unit D indoor ambient temperature sensor error	53	Unit E indoor unit pipe outlet temperature sensor error	C5	Jumper terminal error

Error description of outdoor refrigerant pipe detection function

Wiring error or component error	Unit which is detecting	Unit which isn't detecting
5E	01	**
5E	02	**
5E	03	**
5E	04	**
5E	05	**
Indoor unit gas pipe connection error or component error	Unit which is detecting	--
5P	01	--
5P	02	--
5P	03	--
5P	04	--
5P	05	--

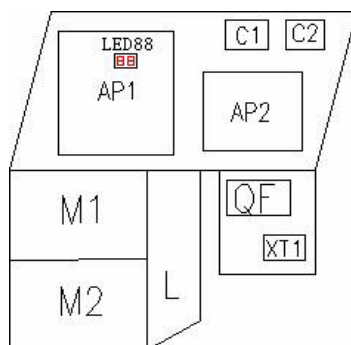

Outdoor Unit: GWHD(36)NK3AO/GWHD(42)NK3AO

(Note: Refer to the real products for the exact position of each component.)

Once errors are displayed on the controller, please shut off the air conditioning unit and contact the professionally skilled personnel for troubleshooting.

2 FLOW CHART OF TROUBLESHOOTING

Service personnel shall collect the malfunction information as much as possible and research them thoroughly, list these electrical parts which may cause malfunction, service personnel shall be able to determine the specific reason and solve the faulted parts.

Observe the status of the complete device and do not observe the partial

It is advised to start from the simple operation during analyzing, judging and confirming malfunction reason, then conduct the complicated operations such removal of device, part replacement and refrigerant filling.

Find the malfunction reason carefully as unit may occur several malfunction at the same time and one malfunction may develop into several malfunction, so entire system analysis shall be established to make the judged result exact and credible.

◆ Malfunction display: E1 Compressor High Pressure Protection

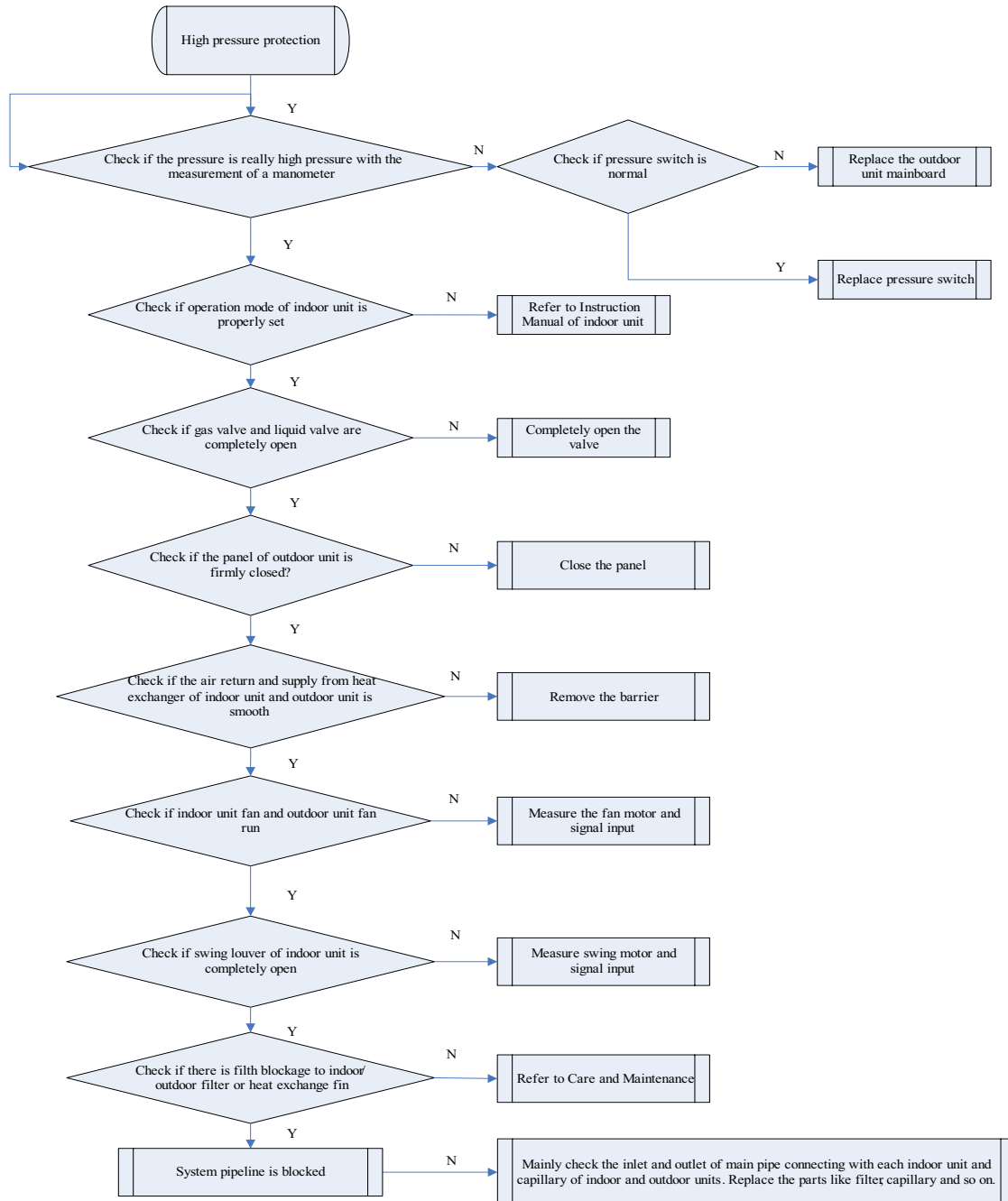

◆ Malfunction display: E3 Compressor Low Pressure Protection

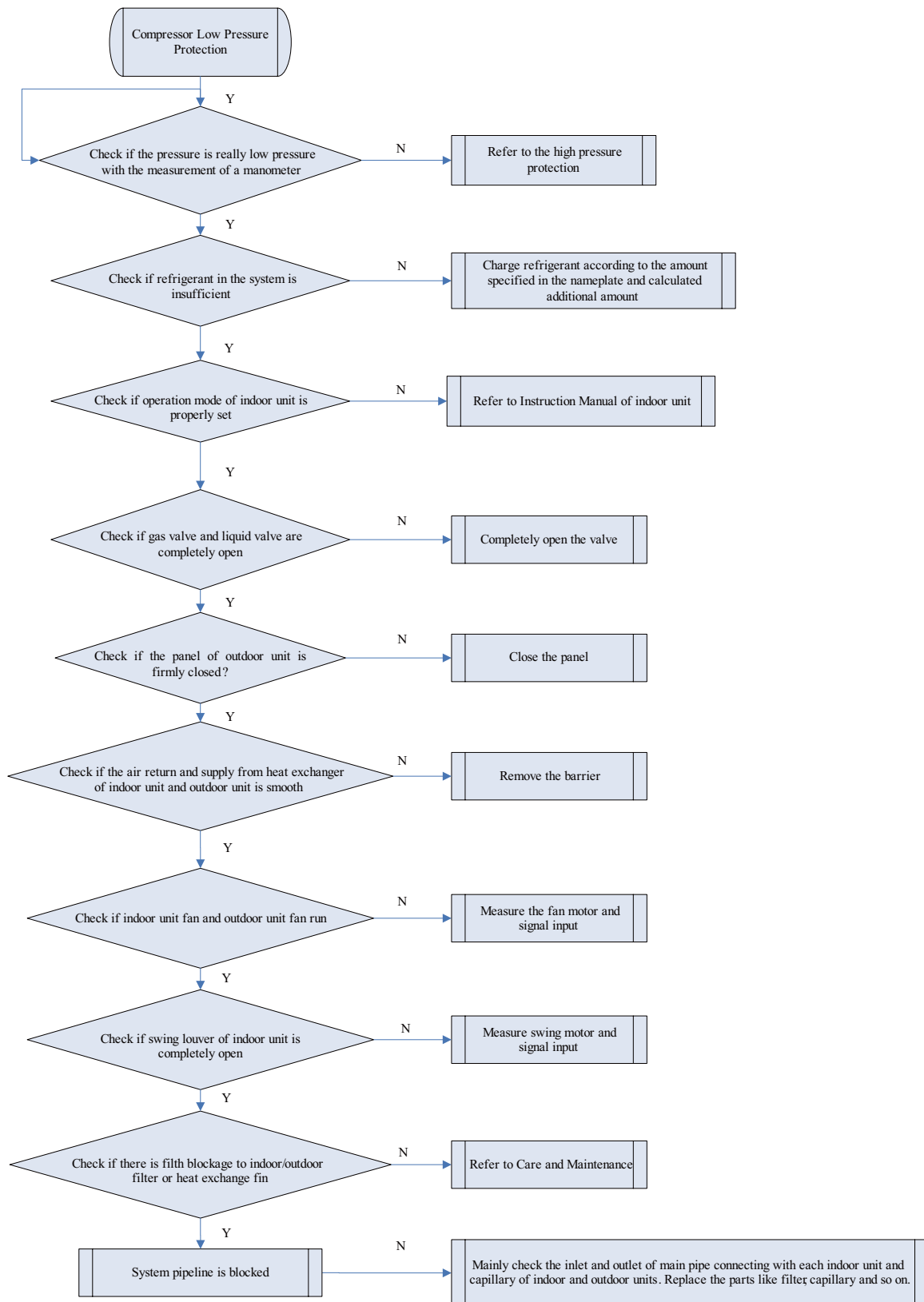

◆ Malfunction display: E4 Compressor Exhaust High Temperature Protection

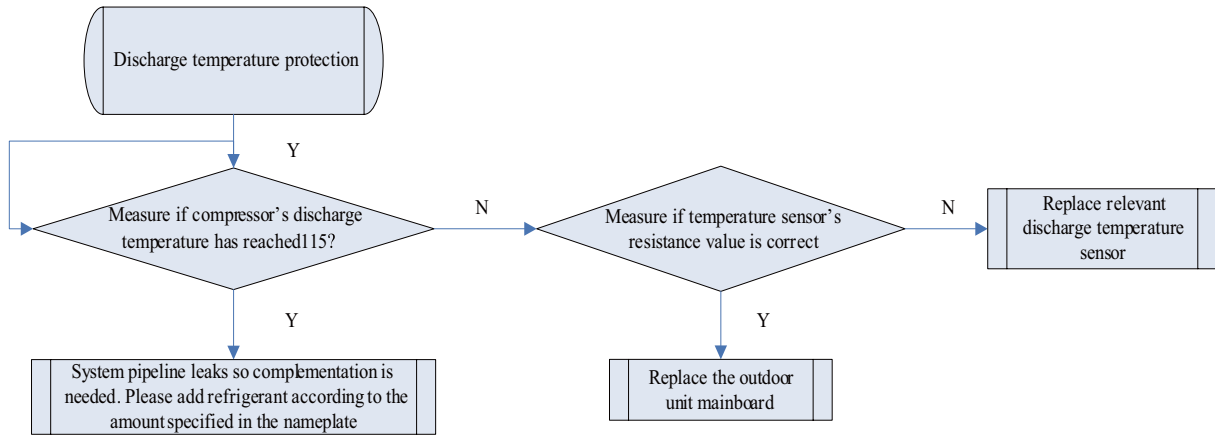

◆ Malfunction display: E5 Compressor Overheat

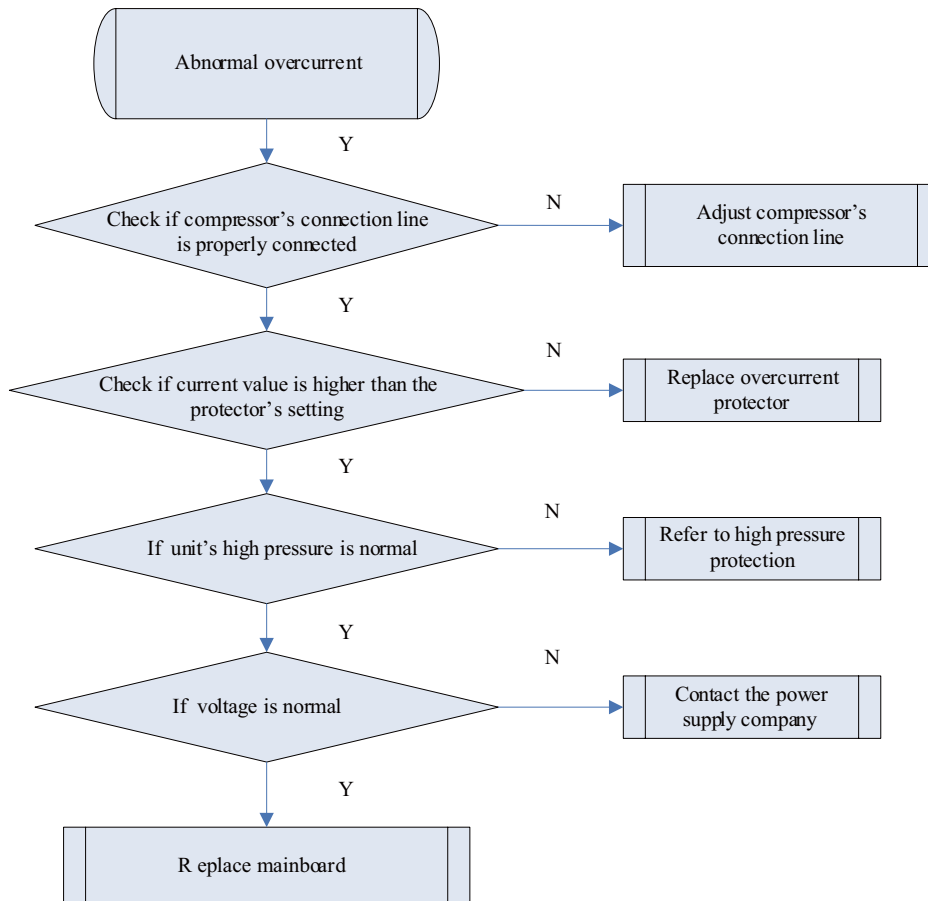

◆ Malfunction display: E9 Full Water Protection

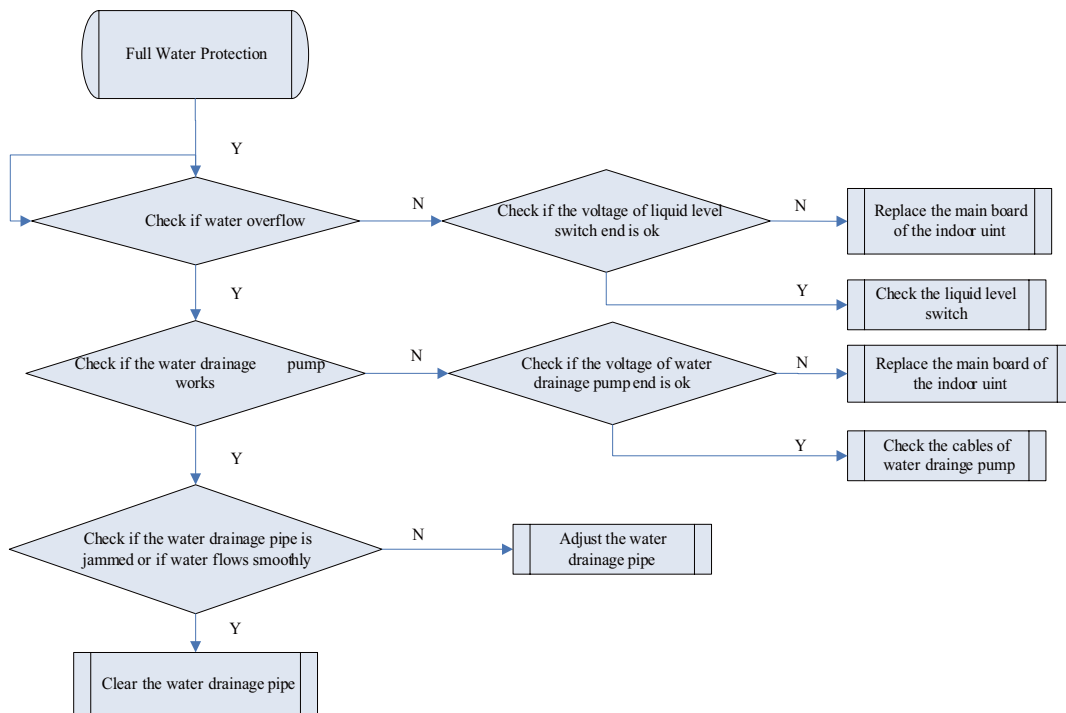

◆ Malfunction display: F2 Failure of Evaporator Temp. Sensor

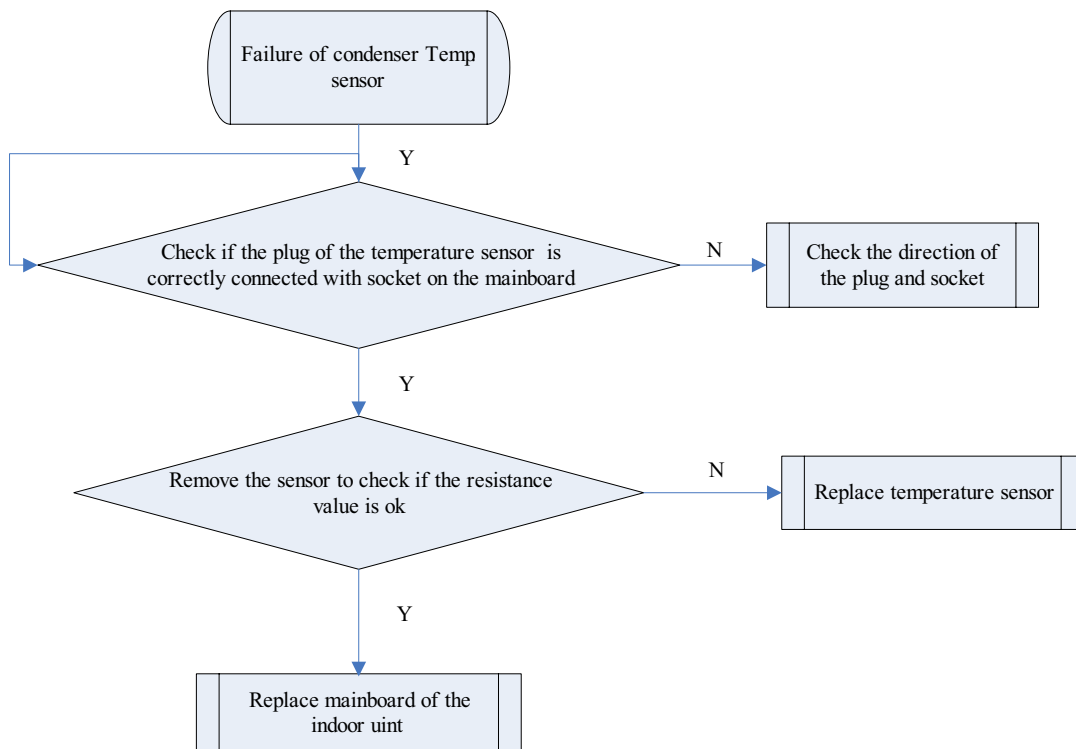

◆ Malfunction display: F3 Failure of Outdoor Ambient Sensor

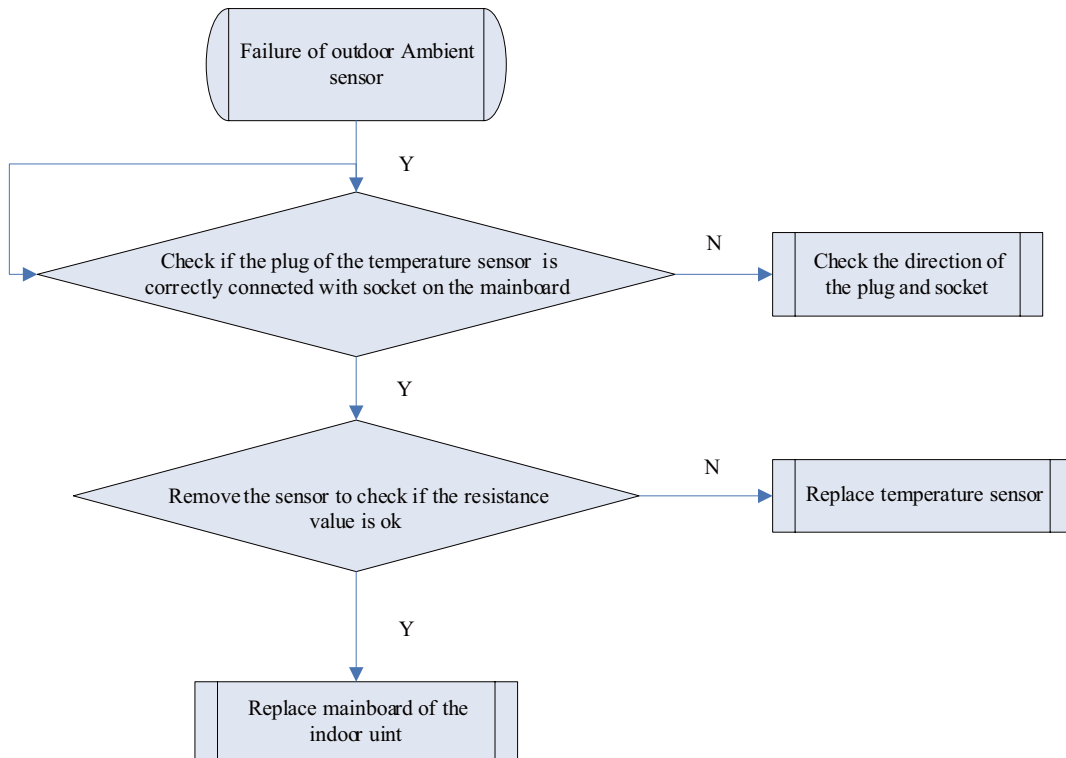

◆ Malfunction display: F5 Failure of Exhaust Temp. Sensor

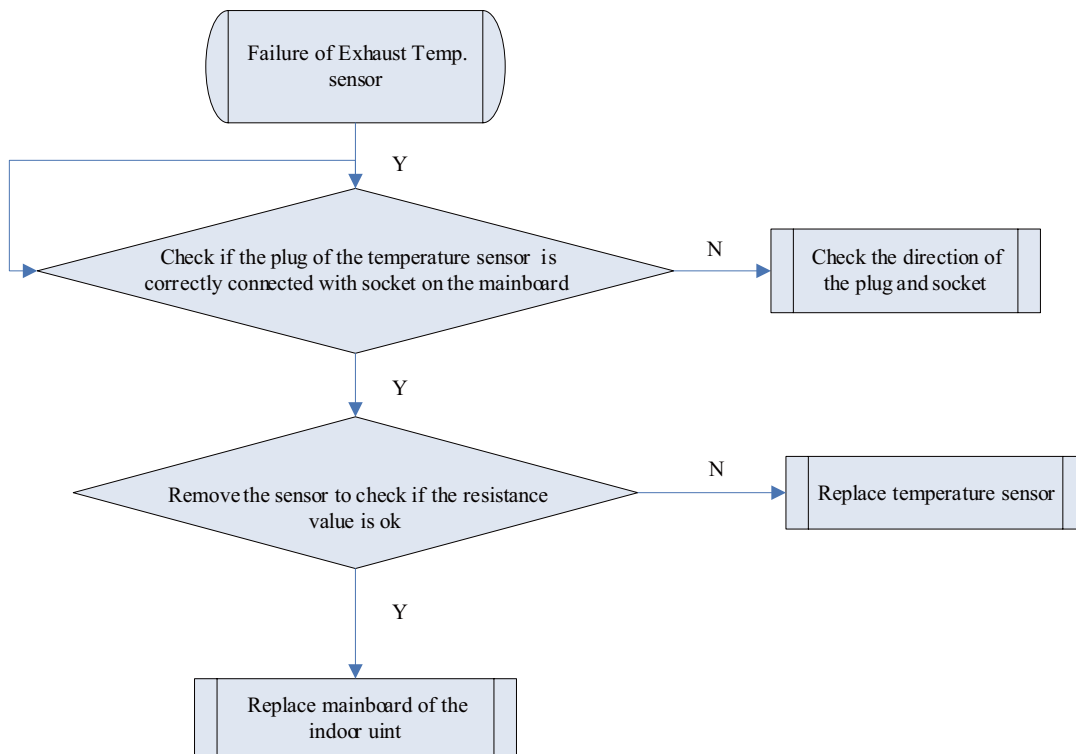

3 WIRING DIADRAM

3.1 Outdoor unit

GWHD(36)NK3AO

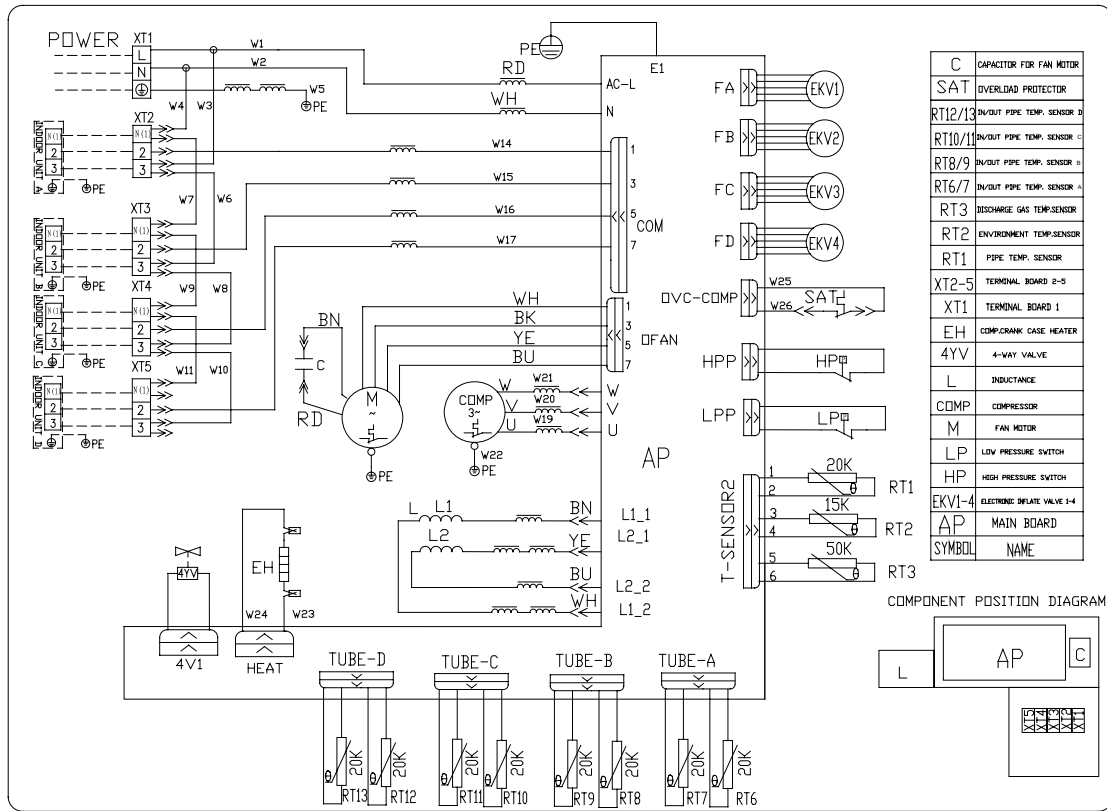

GWHD(42)NK3AO

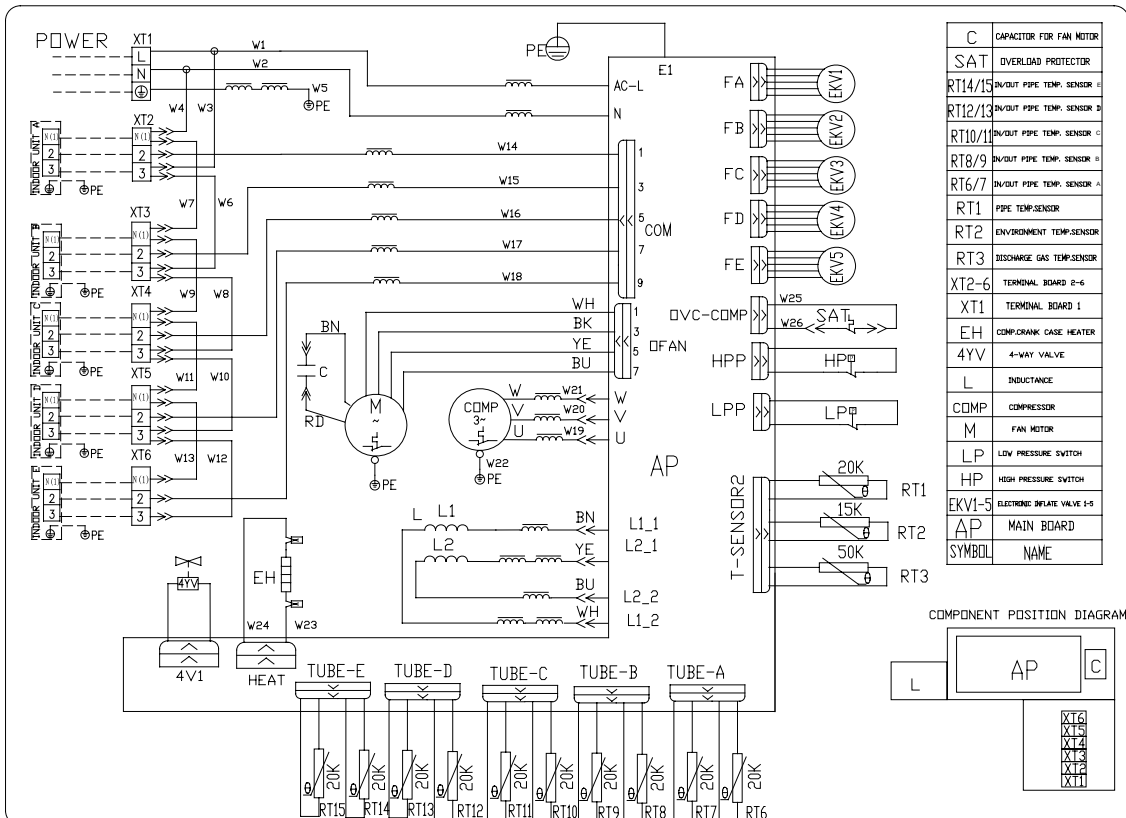

3.2 Indoor unit

3.2.1 Duct type

GFH(09)EA-K3DNA1A/I;GFH(12)EA-K3DNA1A/I;GFH(18)EA-K3DNA1A/I;GFH(21)EA-K3DNA1A/I;GFH(24)EA-K3DNA1A/I

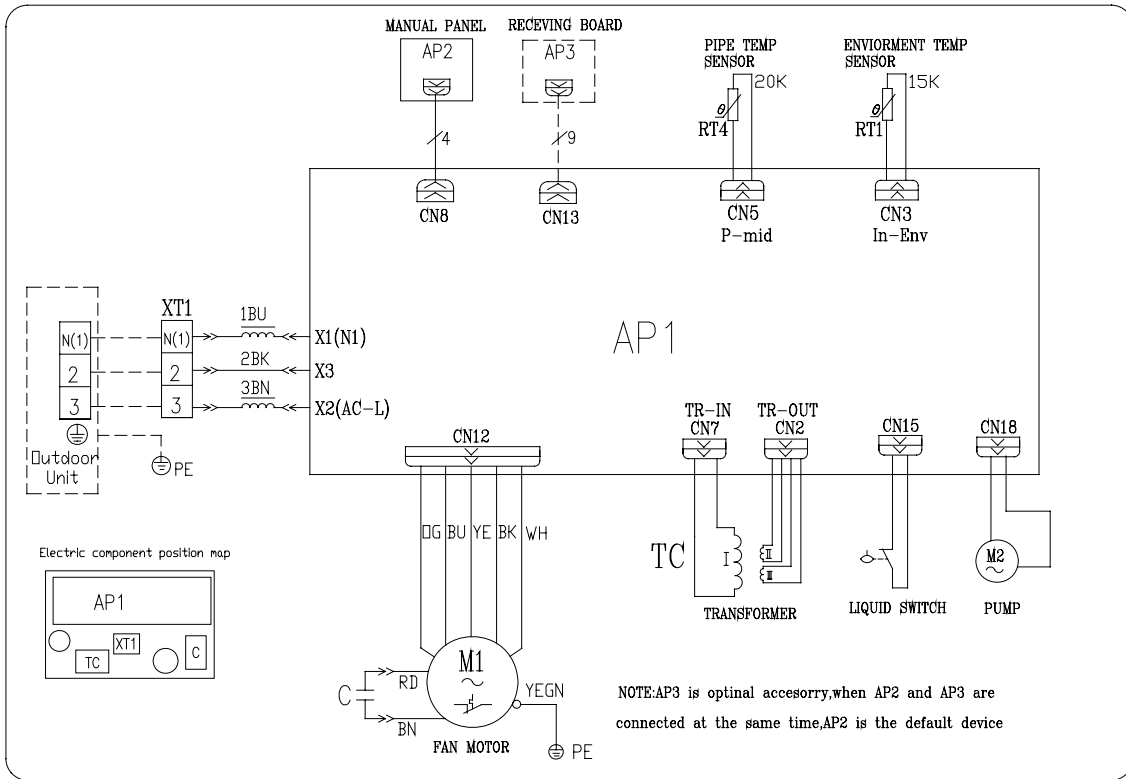

3.2.2 Cassette type

GKH(12)BA-K3DNA1A/I;GKH(18)BA-K3DNA1A/I;GKH(24)BA-K3DNA1A/I

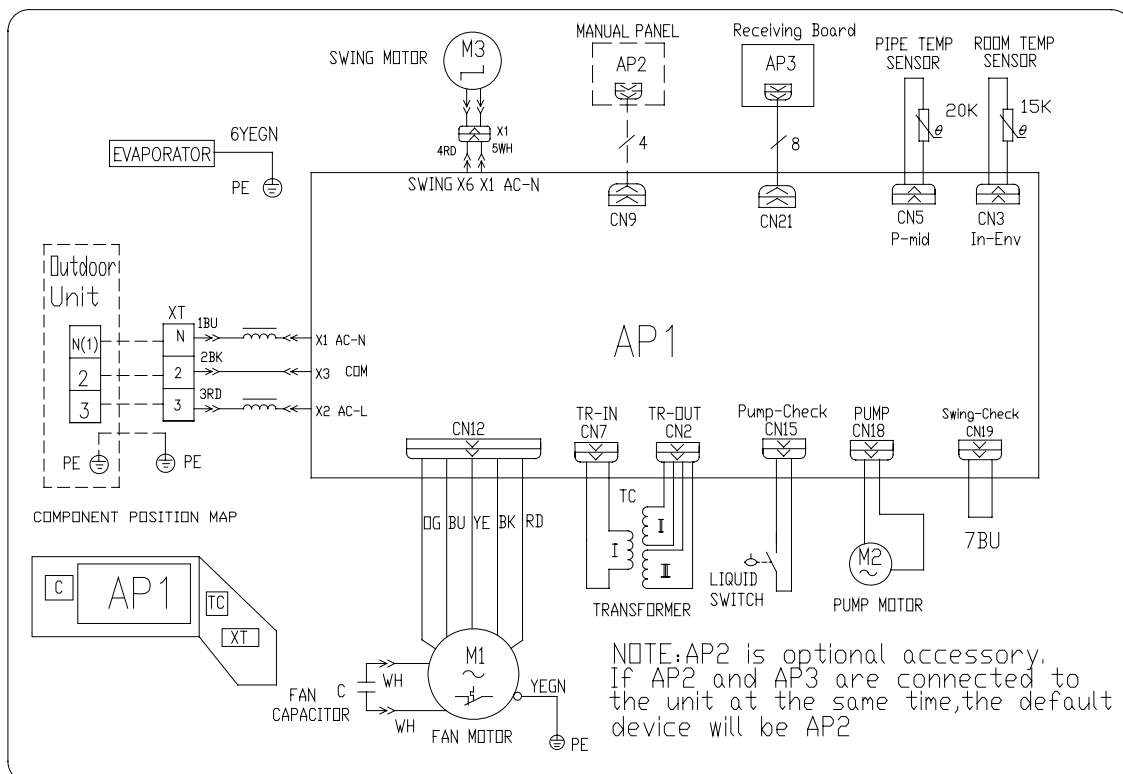

GKH(12)BA-K3DNA2A/I;GKH(18)BA-K3DNA2A/I

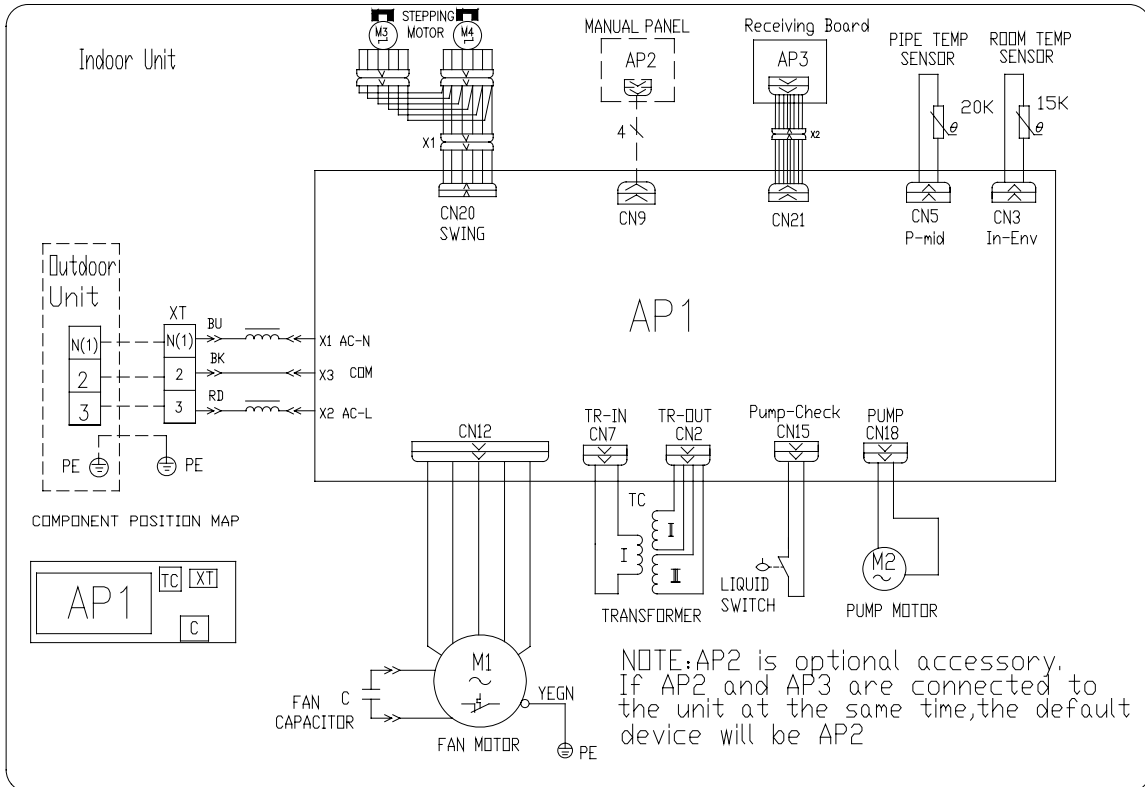

3.2.3 Floor ceiling type

GTH(09)BA-K3DNA1A/I;GTH(12)BA-K3DNA1A/I;GTH(18)BA-K3DNA1A/I;GTH(24)BA-K3DNA1A/I

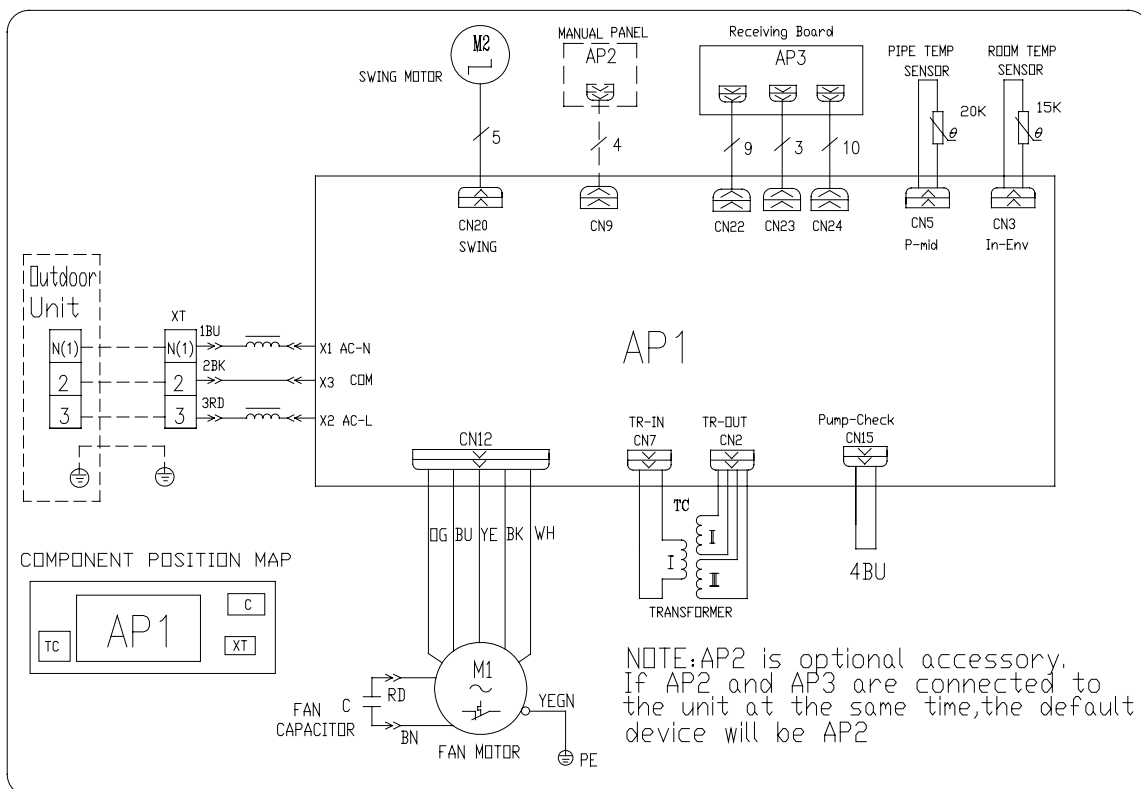

4 DISASSEMBLY AND ASSEMBLY PROCEDURE OF MAIN PARTS

4.1 Outdoor Unit

Side Discharge Indoor Unit

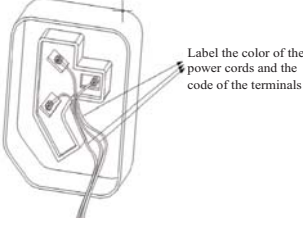
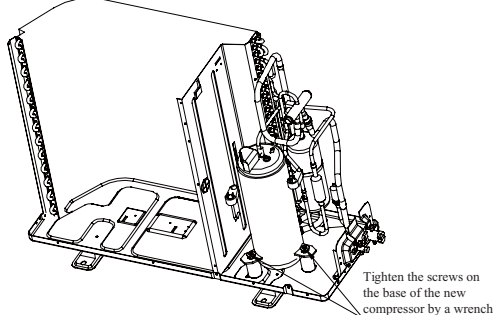
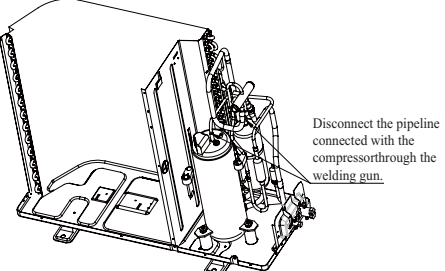
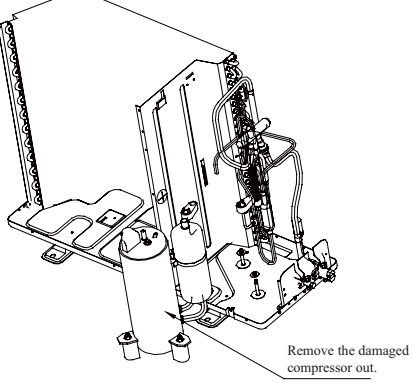
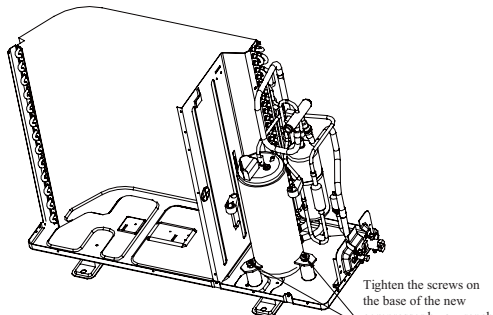
Assembly and Disassembly of the Compressor		
Remarks: Prior to the assembly of the compressor, make sure there is no refrigerant in the pipeline and the power supply is cut off.		
Steps	Illustrations	Operation Instructions
1.Remove the power cords away		<ul style="list-style-type: none"> Loosen the screws used to fix the power cord with a screw driver. Pull out the power cord. <p>Note: when removing the power cord, please label the power cord and the terminals to avoid misconnecting next time.</p>
2.Loosen the screws used to fix the base of the compressor		<ul style="list-style-type: none"> Loosen the screws on the base of the compressor with a wrench.
3.Separate the compressor with the connecting pipe		<ul style="list-style-type: none"> Burn the joint of the connecting pipe of the compressor. Pull out the connecting pipe. <p>Note: never let the flame contact any other componnet.</p>
4.Remove the compressor away from the seating.		<ul style="list-style-type: none"> Remove and replace the compressor <p>Note: never let the flame touch any other component during the replacement.</p>
5.Fix the new compressor on the seating.		<ul style="list-style-type: none"> Tighten the screws on the seating of the new compressor

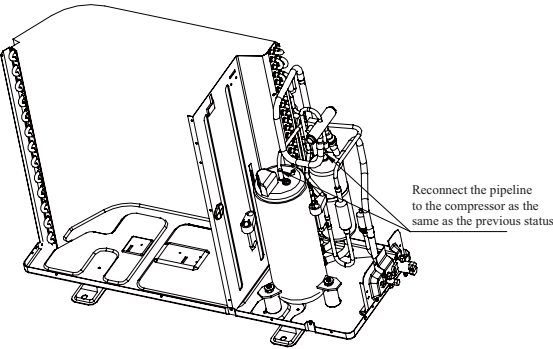
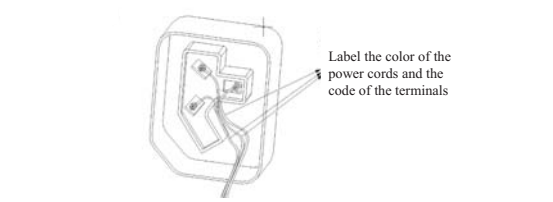
<p>6. Connect the pipeline with the suction and discharge ports of the compressor</p>		<ul style="list-style-type: none"> • Burn the joint of the connecting pipe and then connect the pipeline with the compressor. Note: never let the flame touch any other component.
<p>7. Reconnect the power cord</p>		<ul style="list-style-type: none"> • Tight the screws used to fix the power cord with a screwdriver. • Reconnect the power cord. Note: reconnect the power cord in accordance with the labeled color and terminals.
<p>8. Put the electric heating belt and the discharge temperature sensor etc. in place.</p>		
<p>9. Check if the compressor runs reversely and if the lubricant leaks.</p>		



4.2 Indoor Unit

4.2.1 Duct type

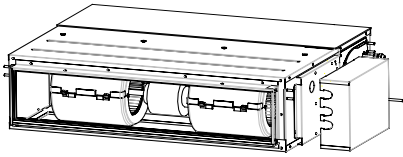
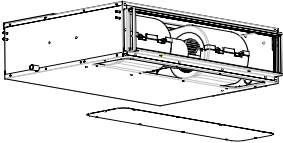
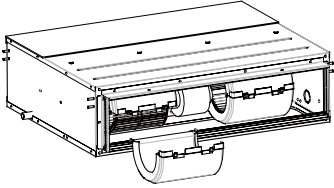
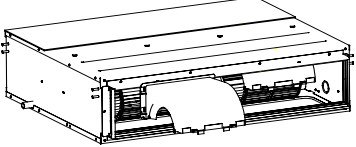
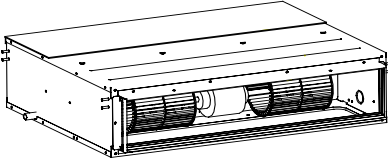
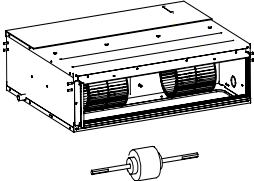
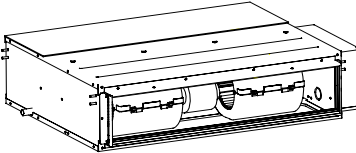
Assembly and Disassembly of the Electric Fan		
Remarks: Prior to the assembly and disassembly, make sure the power supply is cut off.		
Steps	Illustrations	Operation Instructions
1. Pull out the electric wire of the motor.		<ul style="list-style-type: none"> ● Cut off the power supply of the indoor unit, open the cover plate of the electric box and then pull out the electric wire inside the box.
2. Remove the cover plate for return air.		<ul style="list-style-type: none"> ● Loosen the screws used to fix the cover plate for return air with a screwdriver.
3. Remove the rear volute		<ul style="list-style-type: none"> ● Undo the buckle of the rear and front volutes and then remove the rear volute away.
4. Remove the front volute		<ul style="list-style-type: none"> ● Loosen the screws used to fix the front volute and then remove it away.
5. Loosen the fan blade and fan motor		<ul style="list-style-type: none"> ● Loose the screws used to fix the fan blades and then undo the buckle used to fix the motor.
6. Remove the motor away.		<ul style="list-style-type: none"> ● Separate the motor always from the motor frame, remove the fan blade, and lastly take the motor out from the return air frame. As for the motor
7. Repalce the motor.		<ul style="list-style-type: none"> ● Assemble the fan as the reverse disassembly order and then take a power-on test.

4.2.2 Cassette type

Removal and Assembly of Fan Motor		
Step	Illustration	Handling Instruction
1. Loosen the screws fixing the water tray		<ul style="list-style-type: none"> ●Use screwdriver to loosen the screws fixing the water tray
2. Remove the water tray		<ul style="list-style-type: none"> ●Remove the water tray
3. Loosen the bolts fixing the fan		<ul style="list-style-type: none"> ●Use spanner to loosen the bolts fixing the fan.
4. Remove the fan		<ul style="list-style-type: none"> ●Remove the fan
5. Loosen the screws fixing the motor		<ul style="list-style-type: none"> ●Use screwdriver to loosen the screws fixing the motor
6. Remove the motor and replace it		<ul style="list-style-type: none"> ●Remove the motor and replace it
7. Tighten the screws fixing the motor		<ul style="list-style-type: none"> ●Use screwdriver to tighten the screws fixing the motor.
8. Mount the fan and tighten the fixing bolts		<ul style="list-style-type: none"> ●Mount the fan and use spanner to tighten the bolts fixing the fan.

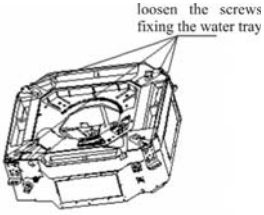
<p>9. Mount the water tray and tighten the screws</p>	 <p>loosen the screws fixing the water tray</p>	<ul style="list-style-type: none"> ●Use screwdriver to loosen the screws fixing the water tray
---	--	---

removal and Installation of Drainage Pump

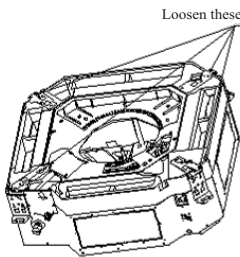
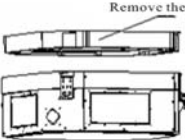
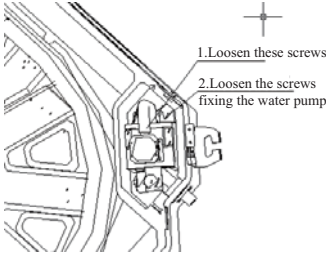
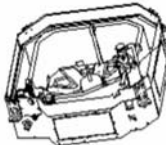
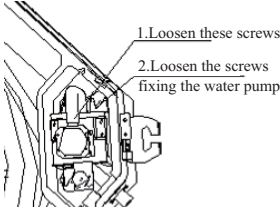
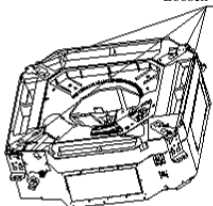
Step	Illustration	Handling Instruction
<p>1. Loosen the screws fixing the water tray</p>	 <p>Loosen these screws</p>	<ul style="list-style-type: none"> ●Use screwdriver to loosen the screws fixing the water tray
<p>2. Remove the water tray</p>	 <p>Remove the water tray</p>	<ul style="list-style-type: none"> ●Remove the water pump and replace it.
<p>3. Pull out the water outlet pipe and loosen the screws fixing the water pump.</p>	 <p>1.Loosen these screws 2.Loosen the screws fixing the water pump</p>	<ul style="list-style-type: none"> ●Pull out the water outlet pipe and use screwdriver to loosen the screws fixing the water pump.
<p>4. Take out the pump and replace it</p>	 <p>Remove the water pump</p>	<ul style="list-style-type: none"> ●Take out the pump and replace it
<p>5. Connect the drainage pipe and tighten the screws fixing the water pump.</p>	 <p>1.Loosen these screws 2.Loosen the screws fixing the water pump</p>	<ul style="list-style-type: none"> ●Connect the drainage pipe and use screwdriver to tighten the screws fixing the water pump.
<p>6. Mount the water tray and tighten the screws</p>	 <p>Loosen these screws</p>	<ul style="list-style-type: none"> ●Use screwdriver to loosen the screws fixing the water tray

4.2.3 Floor ceiling type

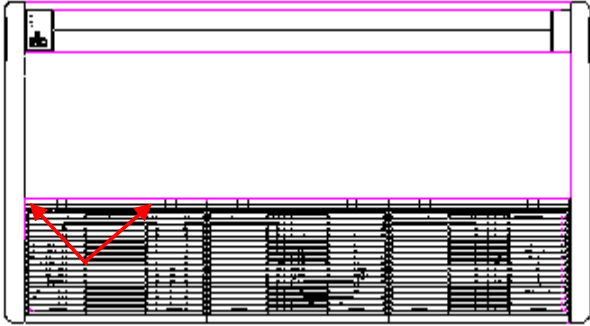
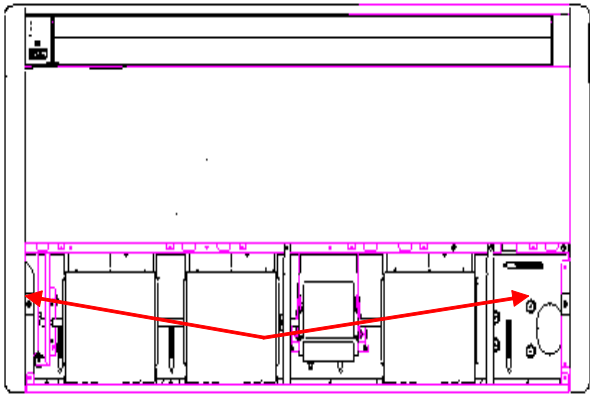
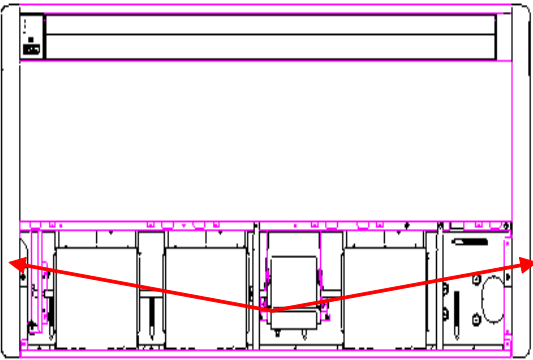
Remove panel grating module		
<p>Remark: Make sure that the power supply is cut off before disassembling and protect all the parts during disassembly. Do not put filter screen near the high temperature heat source.</p>		
Step	Illustration	Handling Instruction
Remove sub-assy of front grill		<ul style="list-style-type: none"> ● Move down the clip of the sub-assy of front grill until the front grill is open. (As is shown in the graph, arrow represents the position of bottoms. There are two clips for each grating.)
Remove right and left finishing plates		
<p>Remark: Make sure the power supply is cut off before disassembling and protect all the parts during disassembly. Do not scratch the outer parts.</p>		
Step	Illustration	Handling Instruction
Remove right and left finishing plates		<ul style="list-style-type: none"> ● Remove the screws as shown in the graph with screwdriver and then push upward to remove the right and left finishing plates. (As is shown in the graph, arrow represents the position of screws.)
Remove right and left finishing plates		<ul style="list-style-type: none"> ● Remove the screws as shown in the graph with screwdriver and then push upward to remove the right and left finishing plates. (As is shown in the graph, arrow represents the position of screws.)

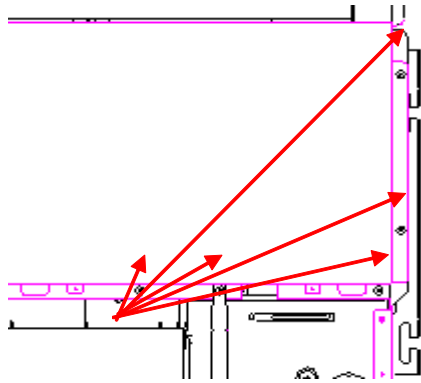
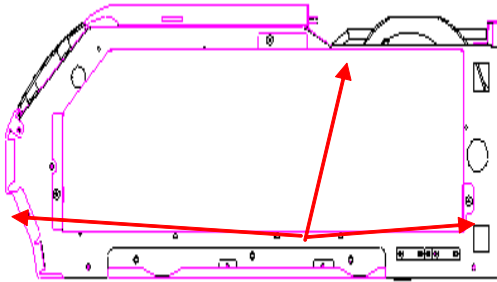
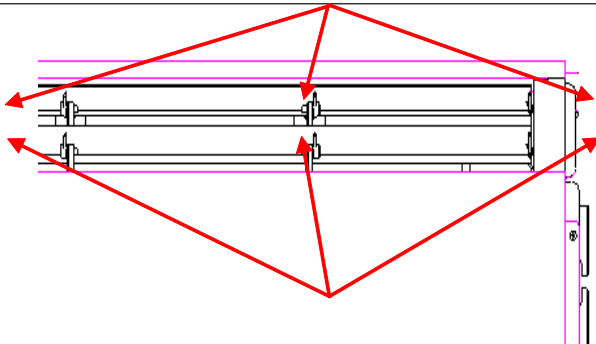
Remove panel parts		
Remark: Make sure the power supply is cut off before disassembling and protect all the parts during disassembly. Do not scratch the outer parts.		
Step	Illustration	Handling Instruction
Remove panel parts		<ul style="list-style-type: none"> Remove the screws shown by the arrow in the graph with screwdriver (two on both right and left and 4 in the front) and then remove the panel parts.
Remove sub-assy of electric box		
Remark: Make sure that the power supply is cut off before disassembling and protect all the parts during disassembly, especially the components inside the box in case of water and hit.		
Step	Illustration	Handling Instruction
1. Remove electric box cover		<ul style="list-style-type: none"> Remove 3 screws as shown by the arrow in the graph on left and remove the electric box cover.
Remove air deflecting plate modules		
Remark: Make sure the power supply is cut off before disassembling and protect all the parts during disassembly, especially the joints of the air deflecting plate.		
Step	Illustration	Handling Instruction
Remove sub-assy of air deflecting plate		<ul style="list-style-type: none"> Remove the air deflecting plates from the air deflecting plate support assembly, and then remove both ends from the air sweeping motor joint. (As is shown in the graph, arrow represents the support assembly and circle the air sweeping motor joint.)

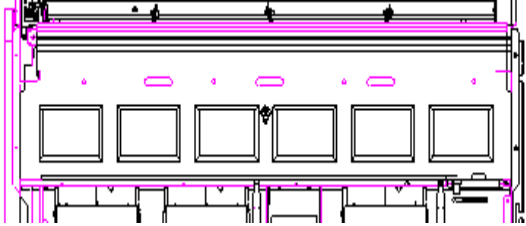
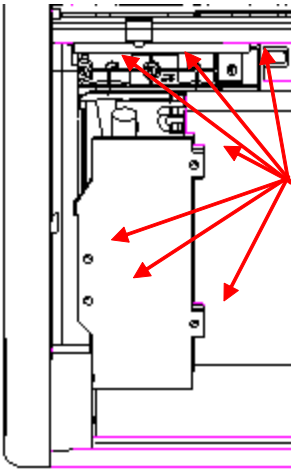
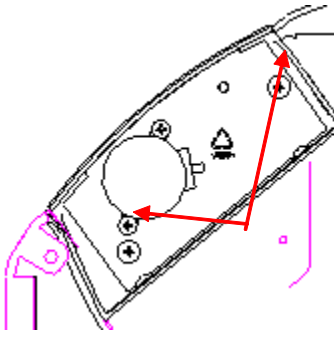
Remove water-containing plate modules		
Remark: Make sure the power supply is cut off before disassembling and protect all the parts during disassembly.		
Step	Illustration	Handling Instruction
Remove water-containing plate modules		<ul style="list-style-type: none"> Remove the water-containing plate modules.
Remove evaporator components		
Remark: Make sure that the power supply is cut off and protect the copper tube and aluminum fin. If the time for disassembly shall be long, seal the copper tube.		
Step	Illustration	Handling Instruction
Remove evaporator components		<ul style="list-style-type: none"> Remove the screws as shown by the arrow in the graph with screwdriver. (There are 6 screws on left and right of the evaporator and 5 on evaporator outlet press plate modules)
Remove fixing plate sub-assy for air sweeping fans		
Remark: Make sure that the power supply is cut off before disassembling and protect all the parts during disassembly.		
Remark: Make sure that the power supply is cut off before disassembling and protect all the parts during disassembly.		
Step	Illustration	Handling Instruction
Remove fixing plate sub-assy for air sweeping fans		<ul style="list-style-type: none"> Remove the screws shown in the graph with screwdriver.

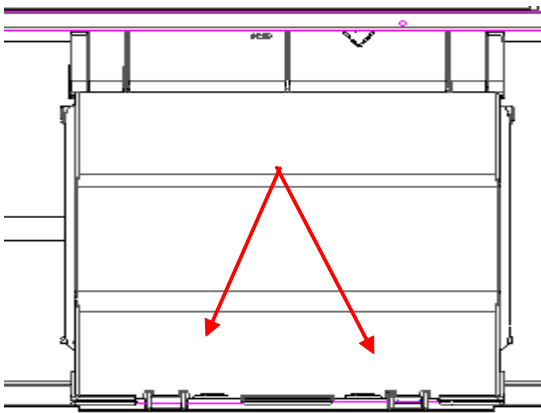
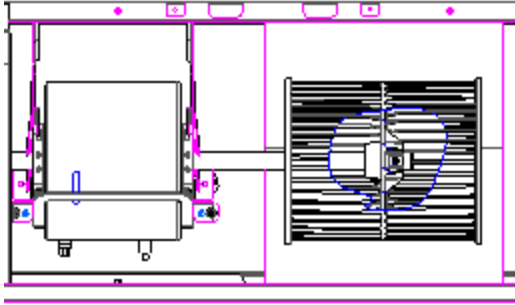
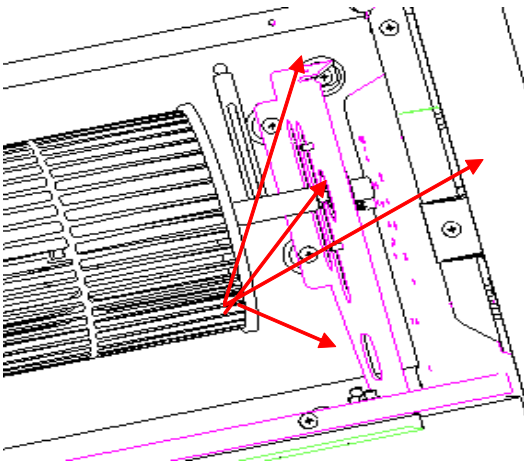
Remove fan and motor components		
Remark: Make sure that the power supply is cut off before disassembling and protect all the parts during disassembly, especially the fastening screws for fans.		
Step	Illustration	Handling Instruction
1. Remove front and back scroll cases		<ul style="list-style-type: none"> ● Press the buckle at the joints of front and back scroll cases with hands and pull upward to remove the front scroll case. Then remove the screws on the back scroll case. Lift the buckle of back scroll case with hands and remove it. (As is shown in the graph, circle represents 2 screws on left and right.)
2. Remove fans		<ul style="list-style-type: none"> ● Remove the fixing screws of fan wheel with inner hexagonal and remove the wheel. The inner hexagonal and its direction of effect are shown by the arrow in the graph.
3. Remove bearing fixing plates		<ul style="list-style-type: none"> ● Remove 4 screws on the bearing fixing plates with screwdriver. (As shown in the box in the graph)

5 EXPLODED VIEWS AND PART LIST

5.1 Outdoor Unit

GWHD(36)NK3AO

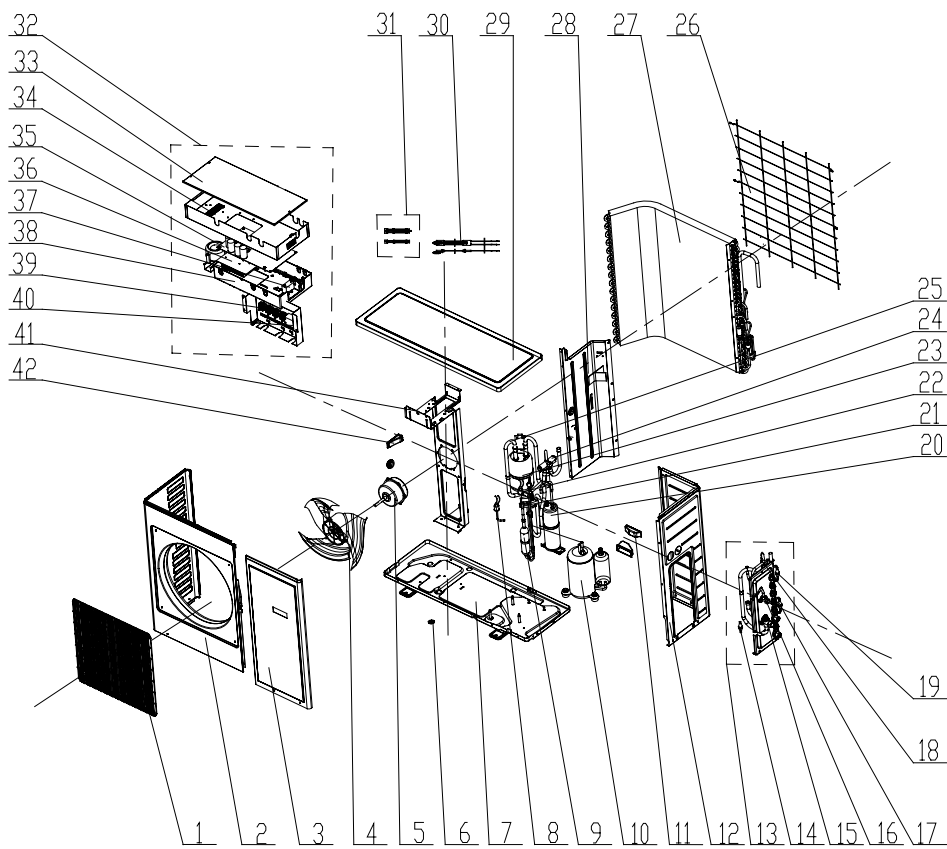

Part list: GWHD(36)NK3AO for CN860W0011

NO.	Description	GWHD(36)NK3AO	
		Code	Qty
1	Front Grill	' 01473001	1
2	Cabinet	' 01433011	1
3	Front Side Plate	' 01305247	1
4	Axial Flow Fan	' 10335253	1
5	Fan Motor	' 1501350202	1
6	Drainage Plug	' 06813401	2
7	Chassis Sub-assy	' 01194310P	1
8	Pressure Protect Switch	' 4602001555	1
9	Oil Separator	' 07424118	1
10	Compressor and fittings	' 00105036	1
11	Handle	' 26235253	2
12	Right Side Plate	' 01314320	1
13	Valve support assy	' 01804398	1
14	StrainerA	' 07210022	1
15	Cut-off Valve	' 07334402	1
16	Cut-off Valve	' 07334403	1
17	StrainerA	' 07210022	1
18	Strainer	' 07212121	1
19	StrainerA	' 07210022	1
20	Bidirection Accumulator	' 07228741	1
21	4-Way Valve Assy	' 04144307	1
22	Pressure Protect Switch	' 4602000902	1
23	Gas-liquid Separator	' 07220030	1
24	4-way Valve	' 43000411	1
25	Inhalation Tube Sub-Assy	' 04674615	1
26	Rear Grill	' 01475252	1
27	Condenser Assy	' 01124188	1
28	Clapboard	' 0123304301	1
29	Top Cover	' 01255013P	1
30	electrical heater	' 76518732	1
31	Sensor Sub-assy	' 39008072	1
32	Electric Box Assy	' 01395143	1
33	Electric Box Cover	' 01424271	1
34	Electric Box Sub-Assy	' 02404128	1
35	Main Board	' 30226252	1
36	Radiator	' 49018029	1
37	Capacitor CBB61	' 33010027	1
38	Electric Box	' 26905211	1
39	Terminal Board	' 420111041	4
40	Terminal Board	' 42010270	1
41	Motor Support	' 01705007	1
42	left handle	' 26235401	1

GWHD(42)NK3AO

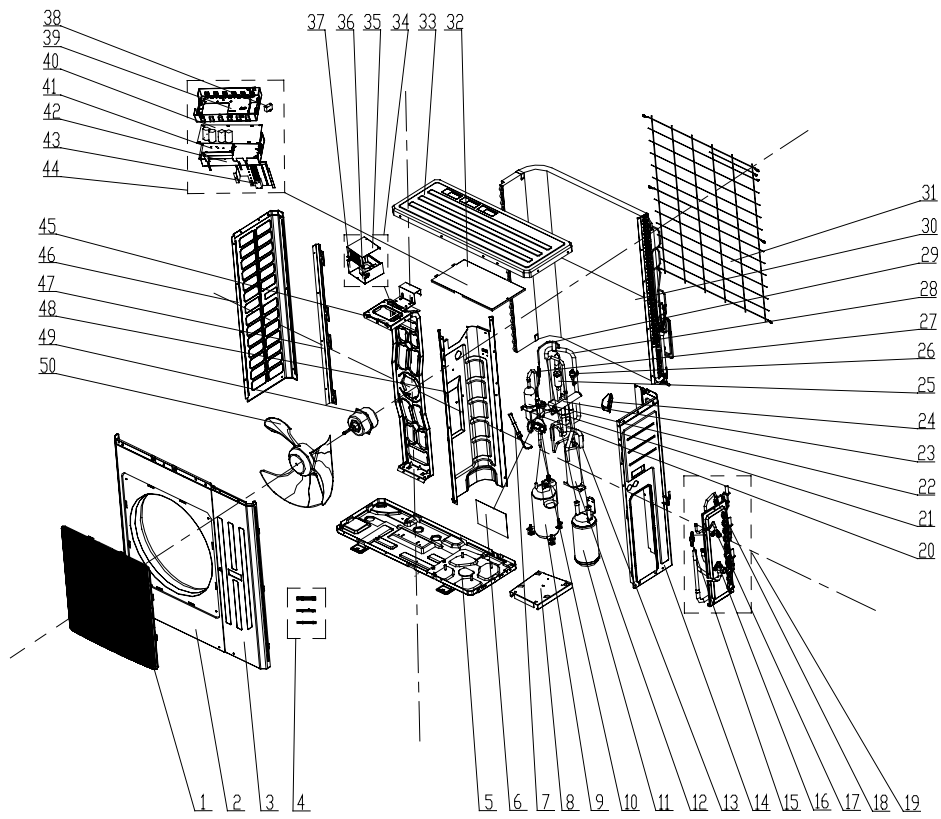

Part list: GWHD(42)NK3AO for CN860W0020

NO.	Description	GWHD(42)NK3AO	
		Code	Qty
1	Front Grill	22415005	1
2	Cabinet	01435007P	1
3	Front Side Plate Sub-Assy	01305508	1
4	Sensor sub-assy	39008066	1
5	Chassis Sub-assy	01194141P	1
6	Insulated board (cover of electric box)	20113003	1
7	Pressure Protect Switch	4602000902	1
8	Compressor Mounting Plate Sub-Assy	01324238	1
9	Compressor and fittings	00205230	1
10	Connection Pipe	05034302	1
11	Gas-liquid Separator Sub-Assy	07225018	1
12	Bidirection Accumulator	07228741	1
13	connecting pipe of "U"shape	05034290	1
14	Right Side Plate Sub-Assy	01314304	1
15	StrainerA	07210022	1
16	Cut-off Valve	07334403	1
17	Cut-off Valve	07334402	1
18	StrainerA	07210022	1
19	Valve support assy	01804238	1
20	Oil Separator	07228302	1
21	Tube Clip	0214000521	1
22	StrainerA	07210022	1
23	4-way Valve	43000338	1
24	Handle	26235253	2
25	4-way Valve Assy	04144185	1
26	Pressure Protect Switch	4602001555	1
27	Discharge Tube Sub-Assy	04634310	1
28	Inhalation Tube Sub-Assy	04674230	1
29	Capillary Sub-Assy(Oil Separator)	04104239	1
30	Condenser Assy	01124179	1
31	Rear Grill	01475012	1
32	Electric Box Cover	01424263	1
33	Top Cover	01255009	1
34	Reactor Sub-Assy	02404111	1
35	Cover of Reactor box	01424260	1
36	PFC Inductance	43128003	1
37	Reactor Box	01424258	1
38	Capacitor	33010009	1
39	Electric Box	26905211	1
40	Main Board	30226254	1
41	Radiator	49018112	1
42	Electric Box Sub-Assy	02404112	1
43	Terminal Board	42010270	1
44	Electric Box Assy	02404113	1
45	Motor Support Sub-Assy	01805402	1
46	Left Side Plate	01305064P	1
47	Condenser support plate	01895309	1
48	Clapboard	01244141	1
49	Fan Motor	1570522801	1
50	Axial Flow Fan	10335010	1

5.2 Indoor Unit

5.2.1 Duct type

GFH(09)EA-K3DNA1A/I

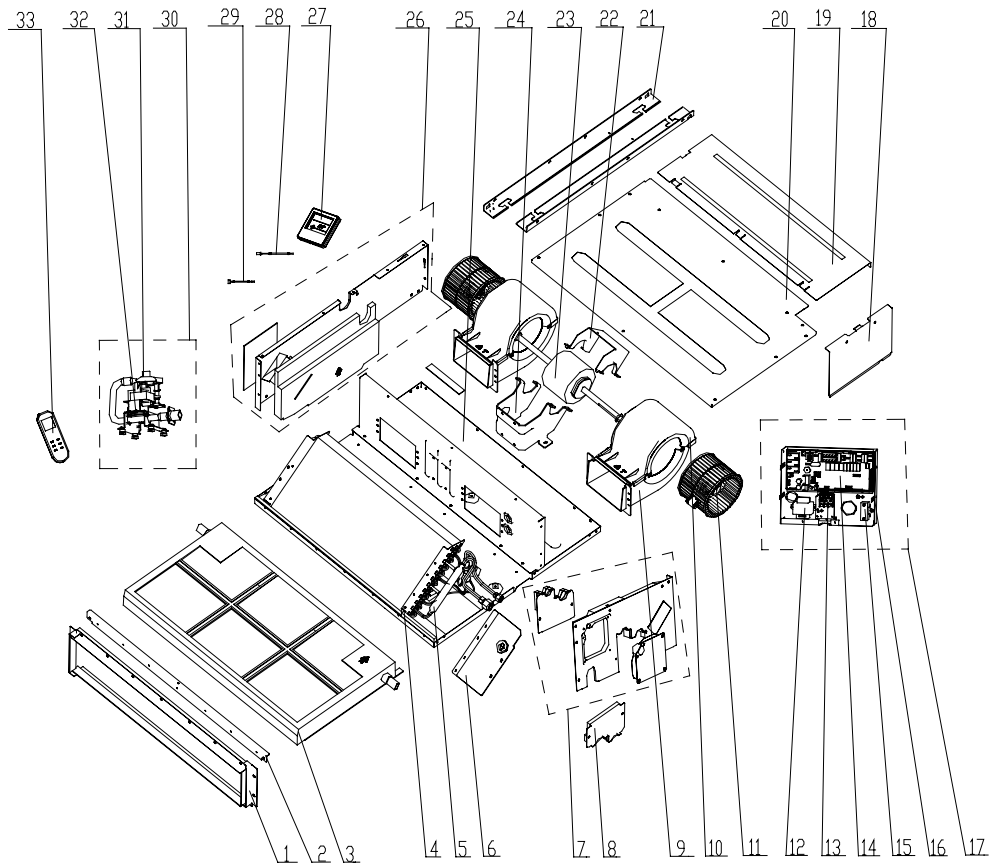

Part list: GFH(09)EA-K3DNA1A/I for CN210N0010

NO.	Description	GFH(09)EA-K3DNA1A/I	
		Code	Qty
1	Air outlet frame assy	01865216	1
2	Cover of air outlet	01265298	1
3	Water Tray Assy	01285332	1
4	Top Cover Board Assy	01265325	1
5	Evaporator Assy	01024266	1
6	Plate of the Evaporator Sub-Assy	01495317	1
7	Left Side Plate Assy	01315334	1
8	Plate of the Exit Tube Sub-Assy	01495316	1
9	Front volute casing	26905205	2
10	Rear volute casing	26905206	2
11	Centrifugal fan	10425200	2
12	Transformer	43110233	1
13	Terminal Board	420111041	1
14	Main Board	30226339	1
15	Capacitor	33010020	1
16	Electric Box Sub-Assy	01395100	1
17	Electric Box assy	01395980	1
18	Electric Box Cover	01424253	1
19	Cover Plate of the Fan	01265300	1
20	Bottom Cover Plate	01265299	1
21	Supporter	01895225	1
22	Bar Clasp	70818405	1
23	Fan Motor	1570520102	1
24	Supporter	01805288	1
25	Fan Mounting Plate Assy	01325312	1
26	Right Side Plate Assy	01315335	1
27	Display Board	30296317	1
28	Ambient Temperature Sensor	39000206	1
29	Temperature Sensor	390001982G	1
30	Water Pump Assy	15405241	1
31	Water Level Switch	45010201	1
32	Water Pump	43130324	1
33	Remote Controller	305100492	1

GFH(12)EA-K3DNA1A/I

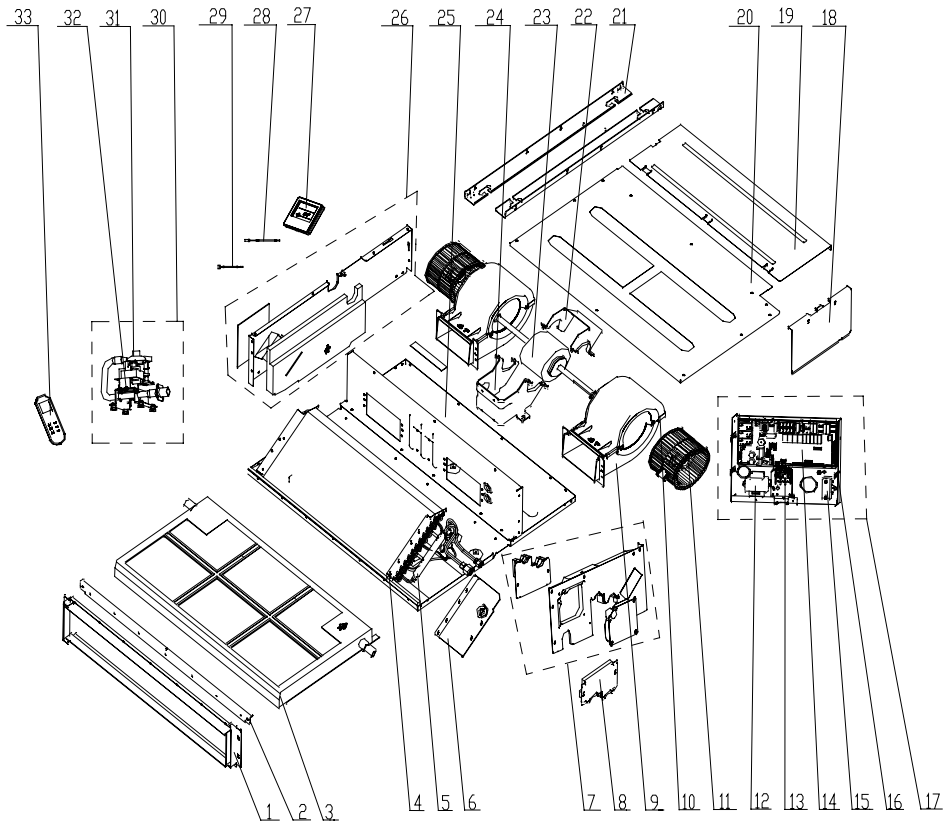



Part list: GFH(12)EA-K3DNA1A/I for CN210N0020

NO.	Description	GFH(12)EA-K3DNA1A/I	
		Code	Qty
1	Air outlet frame assy	01865216	1
2	Cover of air outlet	01265298	1
3	Water Tray Assy	01285332	1
4	Top Cover Board Assy	01265325	1
5	Evaporator Assy	01024905	1
6	Plate of the Evaporator Sub-Assy	01495317	1
7	Left Side Plate Assy	01315334	1
8	Plate of the Exit Tube Sub-Assy	01495316	1
9	Front volute casing	26905205	2
10	Rear volute casing	26905206	2
11	Centrifugal fan	10425200	2
12	Transformer	43110233	1
13	Terminal Board	420111041	1
14	Main Board	30226338	1
15	Capacitor	33010027	1
16	Electric Box Sub-Assy	01395100	1
17	Electric Box assy	01395983	1
18	Electric Box Cover	01424253	1
19	Cover Plate of the Fan	01265300	1
20	Bottom Cover Plate	01265299	1
21	Supporter	01895225	1
22	Bar Clasp	70818405	1
23	Fan Motor	1570520104	1
24	Supporter	01805288	1
25	Fan Mounting Plate Assy	0132531201	1
26	Right Side Plate Assy	01315335	1
27	Display Board	30296317	1
28	Ambient Temperature Sensor	39000206	1
29	Temperature Sensor	390001982G	1
30	Water Pump Assy	15405241	1
31	Water Level Switch	45010201	1
32	Water Pump	43130324	1
33	Remote Controller	305100492	1

GFH(18)EA-K3DNA1A/I

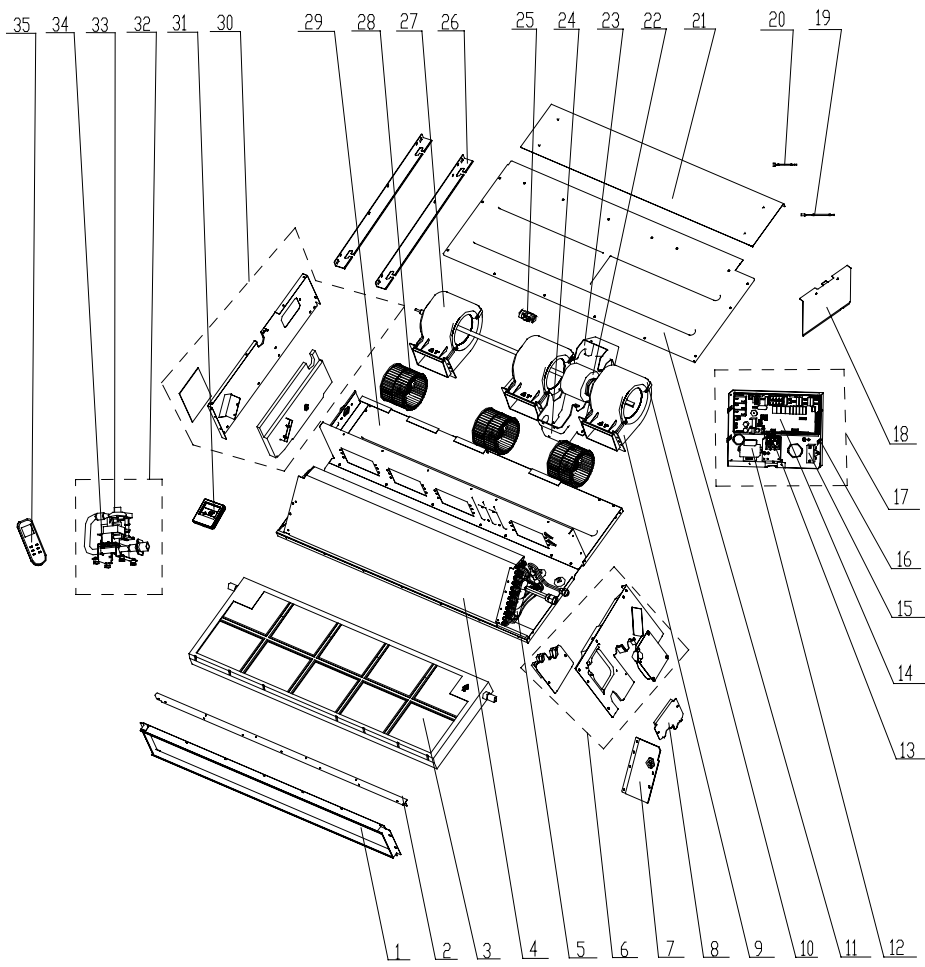

Part list: GFH(18)EA-K3DNA1A/I for CN210N0030

NO.	Description	GFH(18)EA-K3DNA1A/I	
		Code	Qty
1	Air outlet frame assy	01865217	1
2	Cover of air outlet	01265331	1
3	Water Tray Assy	01285333	1
4	Evaporator Assy	01024268	1
5	Lower Cover Plate Sub-Assy	01265328	1
6	Left Side Plate Assy	01315334	1
7	Plate of the Evaporator Sub-Assy	01495317	1
8	Plate of the Exit Tube Sub-Assy	01495316	1
9	Front volute casing	26905205	3
10	Rear volute casing	26905206	3
11	Bottom Cover Plate	80050053	1
12	Transformer	43110233	1
13	Terminal Board	420111041	1
14	Main Board	30226338	1
15	Capacitor	33010027	1
16	Electric Box Sub-Assy	01395100	1
17	Electric Box assy	01395984	1
18	Electric Box Cover	01424253	1
19	Temperature Sensor	39000206	1
20	Ambient Temperature Sensor	39000206	1
21	Cover Plate of the Fan	01265333	1
22	Fan Motor	15705218	1
23	Bar Clasp	70818405	1
24	Supporter	01805288	1
25	Joint Slack	73018731	1
26	Supporter	01895225	1
27	Rotary Axis Sub-Assy	73018731	1
28	Centrifugal fan	10425200	3
29	Fan Mounting Plate Assy	01325314	1
30	Right Side Plate Assy	01305263	1
31	Display Board	30296317	1
32	Water Pump Assy	15405241	1
33	Water Level Switch	45010201	1
34	Water Pump	43130324	1
35	Remote Controller	305100492	1

GFH(21)EA-K3DNA1A/I

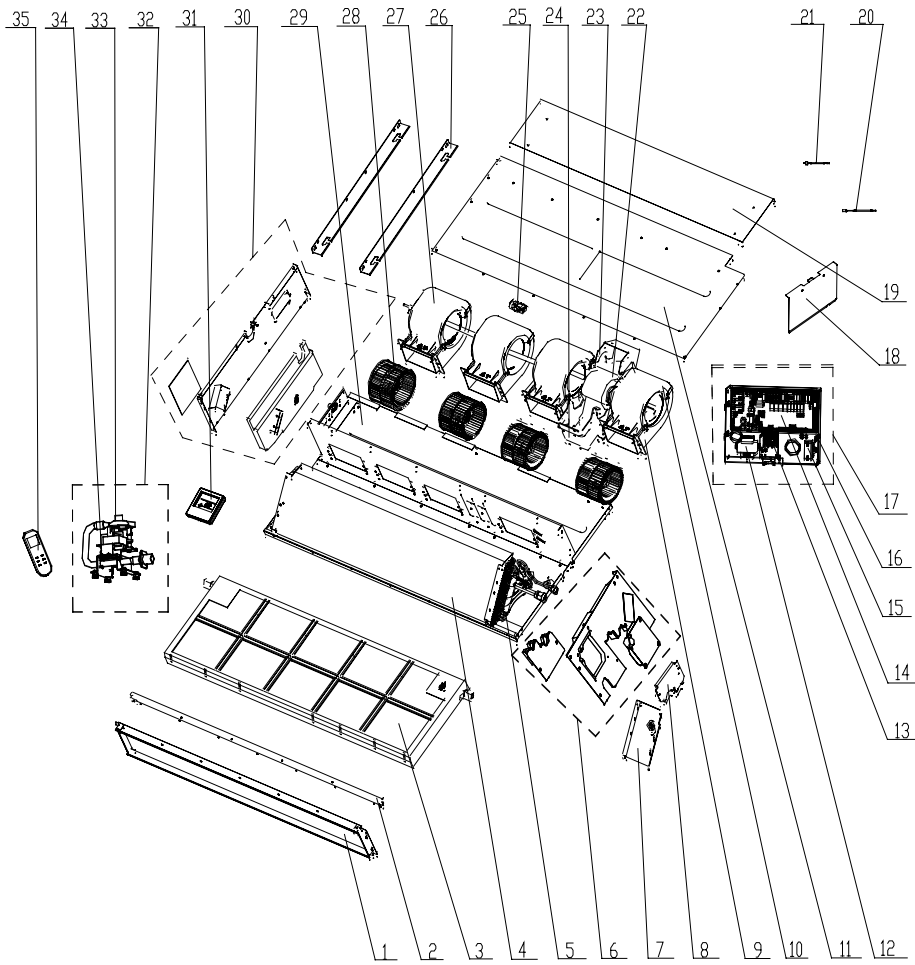

Part list: GFH(21)EA-K3DNA1A/I for CN210N0040

NO.	Description	GFH(21)EA-K3DNA1A/I	
		Code	Qty
1	Air outlet frame assy	01375224	1
2	Cover of air outlet	01265335	1
3	Water Tray Assy	01285334	1
4	Evaporator Assy	01024269	1
5	Lower Cover Plate Sub-Assy	01265339	1
6	Left Side Plate Assy	01315334	1
7	Plate of the Evaporator Sub-Assy	01495317	1
8	Plate of the Exit Tube Sub-Assy	01495316	1
9	Front volute casing	26905205	3
10	Rear volute casing	26905206	3
11	Bottom Cover Plate	01265337	1
12	Transformer	43110233	1
13	Terminal Board	420111041	1
14	Main Board	30226338	1
15	Capacitor	33010027	1
16	Electric Box Sub-Assy	01395100	1
17	Electric Box assy	01395985	1
18	Electric Box Cover	01424253	1
19	Cover Plate of the Fan	01265338	1
20	Temperature Sensor	39000206	1
21	Ambient Temperature Sensor	390001982G	1
22	Fan Motor	1570411102	1
23	Bar Clasp	70818405	1
24	Supporter	01805288	1
25	Joint Slack	73018731	1
26	Supporter	01895225	1
27	Rotary Axis Sub-Assy	73018022	1
28	Centrifugal fan	10425200	3
29	Fan Mounting Plate Assy	01325316	1
30	Right Side Plate Assy	01305263	1
31	Display Board	30296317	1
32	Water Pump Assy	15405241	1
33	Water Level Switch	45010201	1
34	Water Pump	43130324	1
35	Remote Controller	305100492	1

GFH(24)EA-K3DNA1A/I

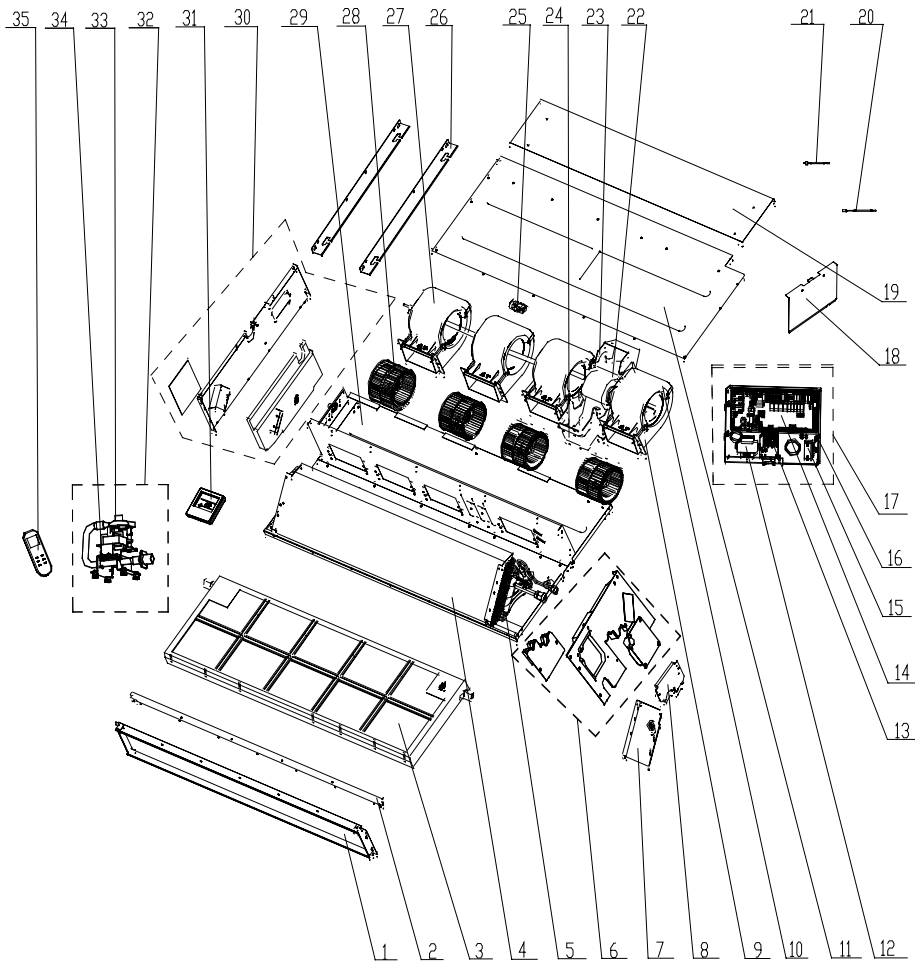

Part list: GFH(24)EA-K3DNA1A/I for CN210N0050

NO.	Description	GFH(21)EA-K3DNA1A/I	
		Code	Qty
1	Air outlet frame assy	01375224	1
2	Cover of air outlet	01265335	1
3	Water Tray Assy	01285334	1
4	Evaporator Assy	01024269	1
5	Lower Cover Plate Sub-Assy	01265339	1
6	Left Side Plate Assy	01315334	1
7	Plate of the Evaporator Sub-Assy	01495317	1
8	Plate of the Exit Tube Sub-Assy	01495316	1
9	Front volute casing	26905205	3
10	Rear volute casing	26905206	3
11	Bottom Cover Plate	01265337	1
12	Transformer	43110233	1
13	Terminal Board	420111041	1
14	Main Board	30226338	1
15	Capacitor	33010027	1
16	Electric Box Sub-Assy	01395100	1
17	Electric Box assy	01395985	1
18	Electric Box Cover	01424253	1
19	Cover Plate of the Fan	01265338	1
20	Temperature Sensor	39000206	1
21	Ambient Temperature Sensor	390001982G	1
22	Fan Motor	1570411102	1
23	Bar Clasp	70818405	1
24	Supporter	01805288	1
25	Joint Slack	73018731	1
26	Supporter	01895225	1
27	Rotary Axis Sub-Assy	73018022	1
28	Centrifugal fan	10425200	3
29	Fan Mounting Plate Assy	01325316	1
30	Right Side Plate Assy	01305263	1
31	Display Board	30296317	1
32	Water Pump Assy	15405241	1
33	Water Level Switch	45010201	1
34	Water Pump	43130324	1
35	Remote Controller	305100492	1

5.2.2 Cassette type

GKH(12)BA-K3DNA1A/I

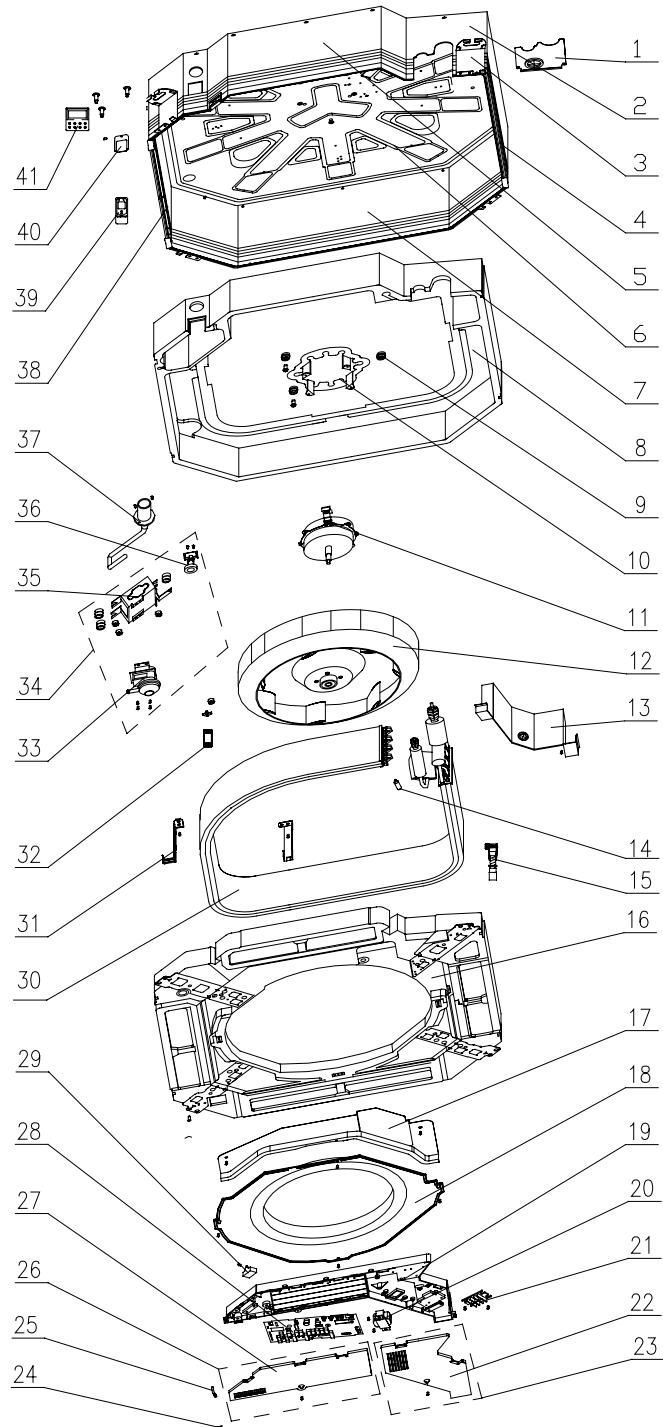

Part list: GKH(12)BA-K3DNA1A/I for CN510N0010

NO.	Description	GKH(12)BA-K3DNA1A/I	
		Code	Qty
1	Tube Exit Plate Assy	01382717	1
2	Shell Assy	01432701	1
3	Body Installing Plate	01332701	1
4	Front Side Plate Assy	01302717	1
5	Left Side Plate Assy	01302740	1
6	Base Plate Assy	01222701	1
7	Rear Side Plate Assy	01302719	1
8	Bottom Foam Assy	52012720	1
9	Motor Gasket	76712711	4
10	Motor Support	01702701	1
11	Fan Motor	15704901	1
12	Centrifugal Fan	10312721	1
13	Connected Board Assy Of Evaporator	01072731	1
14	Filter Sub-Assy	11120011	1
15	Drain Hose Sub-Assy	05232703	1
16	Water Tray Assy	20182701	1
17	Electric Base Plate	01412721	1
18	Diversion Circle	10372701	1
19	Electric Box Assy	01399519	1
20	Terminal Board	42011222	1
21	Transformer	43110233	1
22	Electric Box Cover I	20102702	1
23	Electric Box Cover Sub-Assy1	20122054	1
24	Temperature Sensor	390001982G	1
25	Ambient Temperature Sensor	390000453	1
26	Electric Box Cover Sub-Assy2	20122055	1
27	Electric Box Cover II	20102703	1
28	Main Board	30226340	1
29	Capacitor CBB61	33010027	1
30	Evaporator Assy	01004643	1
31	Evaporator Support Assy	01072704	2
32	Magnetic Ring	49010104	1
33	Water Pump	43130324	1
34	Water Pump Assy	01332750	1
35	Pump Support	01324201	1
36	Water Level Switch	45010201	1
37	Pump Drainpipe	05232721	1
38	Right Side Plate Assy	01302710	1
39	Remote Controller	305125063	1
40	Pump Cover Board Assy	01252712	1
41	Display Board	30296317	1

GKH(18)BA-K3DNA1A/I

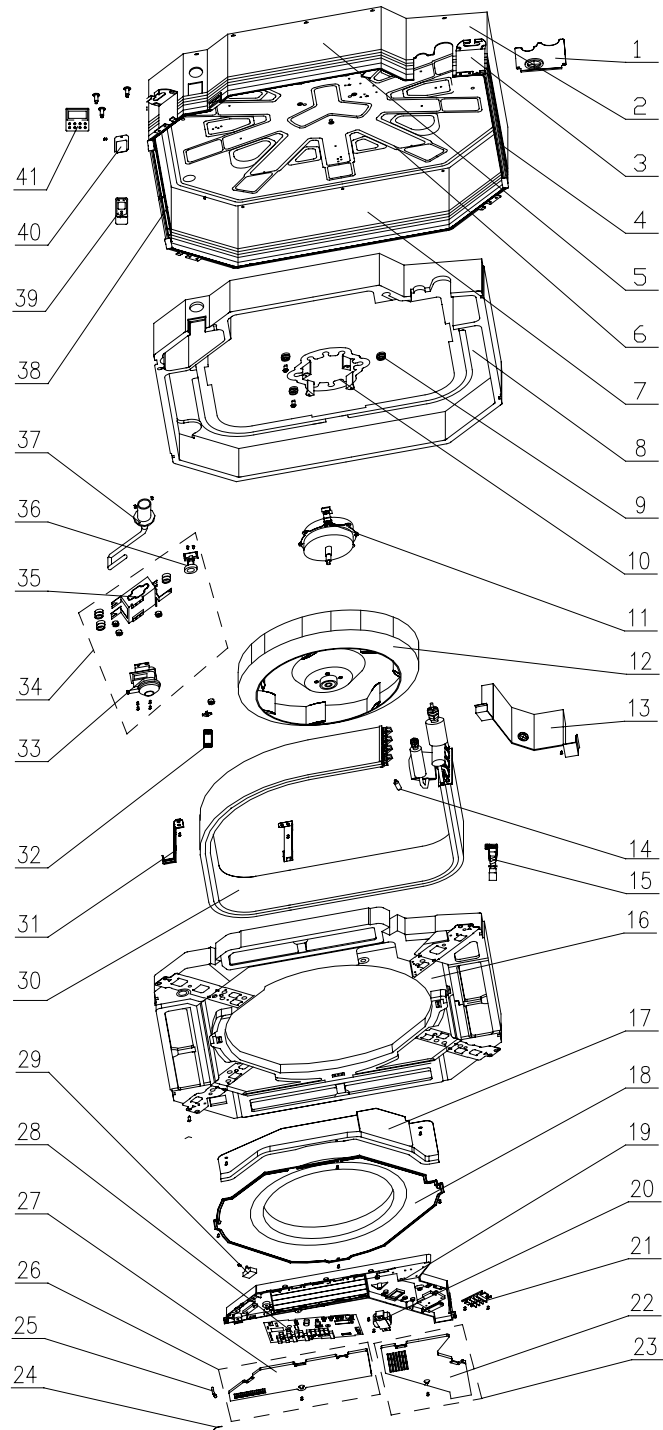

Part list: GKH(18)BA-K3DNA1A/I for CN510N0020

NO.	Description	GKH(18)BA-K3DNA1A/I	
		Code	Qty
1	Tube Exit Plate Assy	01382717	1
2	Shell Assy	01432701	1
3	Body Installing Plate	01332701	1
4	Front Side Plate Assy	01302717	1
5	Left Side Plate Assy	01302740	1
6	Base Plate Assy	01222701	1
7	Rear Side Plate Assy	01302719	1
8	Bottom Foam Assy	52012720	1
9	Motor Gasket	76712711	4
10	Motor Support	01702701	1
11	Fan Motor	15704901	1
12	Centrifugal Fan	10312721	1
13	Connected Board Assy Of Evaporator	01072731	1
14	Filter Sub-Assy	11120011	1
15	Drain Hose Sub-Assy	05232703	1
16	Water Tray Assy	20182701	1
17	Electric Base Plate	01412721	1
18	Diversion Circle	10372701	1
19	Electric Box Assy	01399519	1
20	Terminal Board	42011222	1
21	Transformer	43110233	1
22	Electric Box Cover I	20102702	1
23	Electric Box Cover Sub-Assy1	20122054	1
24	Temperature Sensor	390001982G	1
25	Ambient Temperature Sensor	390000453	1
26	Electric Box Cover Sub-Assy2	20122055	1
27	Electric Box Cover II	20102703	1
28	Main Board	30226340	1
29	Capacitor CBB61	33010027	1
30	Evaporator Assy	01004642	1
31	Evaporator Support Assy	01072704	2
32	Magnetic Ring	49010104	1
33	Water Pump	43130324	1
34	Water Pump Assy	01332750	1
35	Pump Support	01324201	1
36	Water Level Switch	45010201	1
37	Pump Drainpipe	05232721	1
38	Right Side Plate Assy	01302710	1
39	Remote Controller	305100492	1
40	Pump Cover Board Assy	01252712	1
41	Display Board	30296317	1

GKH(24)BA-K3DNA1A/I

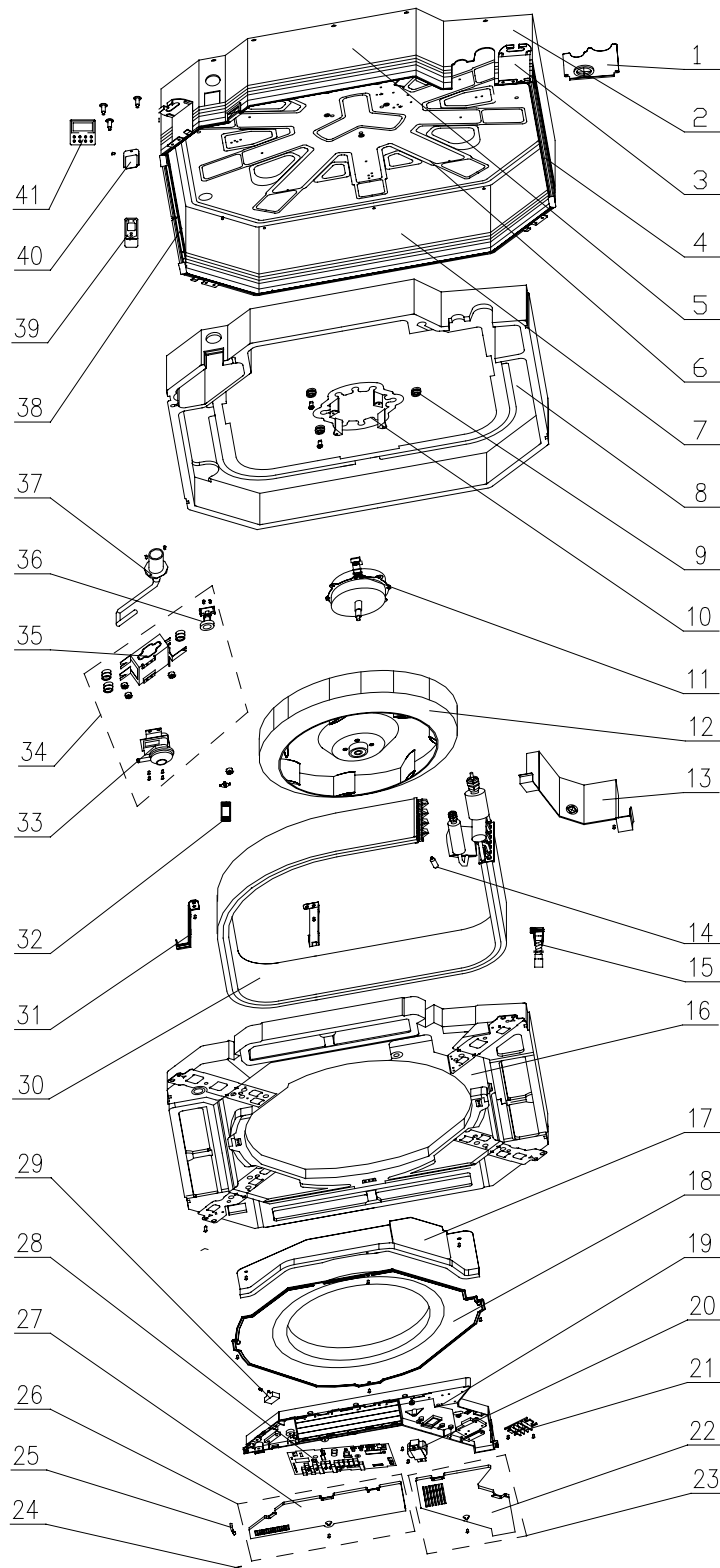



Part list: GKH(24)BA-K3DNA1A/I for CN510N0030

NO.	Description	GKH(24)BA-K3DNA1A/I	
		Code	Qty
1	Tube Exit Plate Assy	01382715	1
2	Shell Assy	01432704	1
3	Body Installing Plate	01332701	1
4	Front Side Plate Assy	01302718	1
5	Left Side Plate Assy	01302715	1
6	Base Plate Assy	01222701	1
7	Rear Side Plate Assy	01302714	1
8	Bottom Foam Assy	52012722	1
9	Motor Gasket	76712711	4
10	Motor support	01702701	1
11	Fan Motor	15704102	1
12	Centrifugal Fan	10312705	1
24	Temperature Sensor	390001982G	1
37	Pump Drainpipe	05230026	1
38	Right Side Plate Assy	01302716	1
39	Remote Controller	305125063	1
13	Connected Board Assy Of Evaporator	01074042	1
14	Filter Sub-Assy	07210028	1
15	Drain Hose Sub-Assy	05232702	1
16	Water Tray Assy	20182701	1
17	Electric Base Plate	01412721	1
18	Diversion Circle	10372701	1
19	Electric Box Assy	01399520	1
20	Transformer	43110233	1
21	Terminal Board	42011222	1
22	Electric Box Cover I	20102702	1
23	Electric Box Cover Sub-Assy1	20122054	1
25	Ambient Temperature Sensor	390000453	1
26	Electric Box Cover Sub-Assy2	20122055	1
27	Electric Box Cover II	20102703	1
28	Main Board	30226340	1
29	Capacitor CBB61	33010027	1
30	Evaporator Assy	01004641	1
31	Evaporator Support Assy	01072703	2
32	Magnetic Ring	49010104	1
33	Water Pump	43130324	1
34	Water Pump Assy	01332752	1
35	Pump Support	01332702	1
36	Water Level Switch	45010201	1
40	Pump Cover Board Assy	01252713	1
41	Display Board	30296317	1

GKH(12)BA-K3DNA2A/I

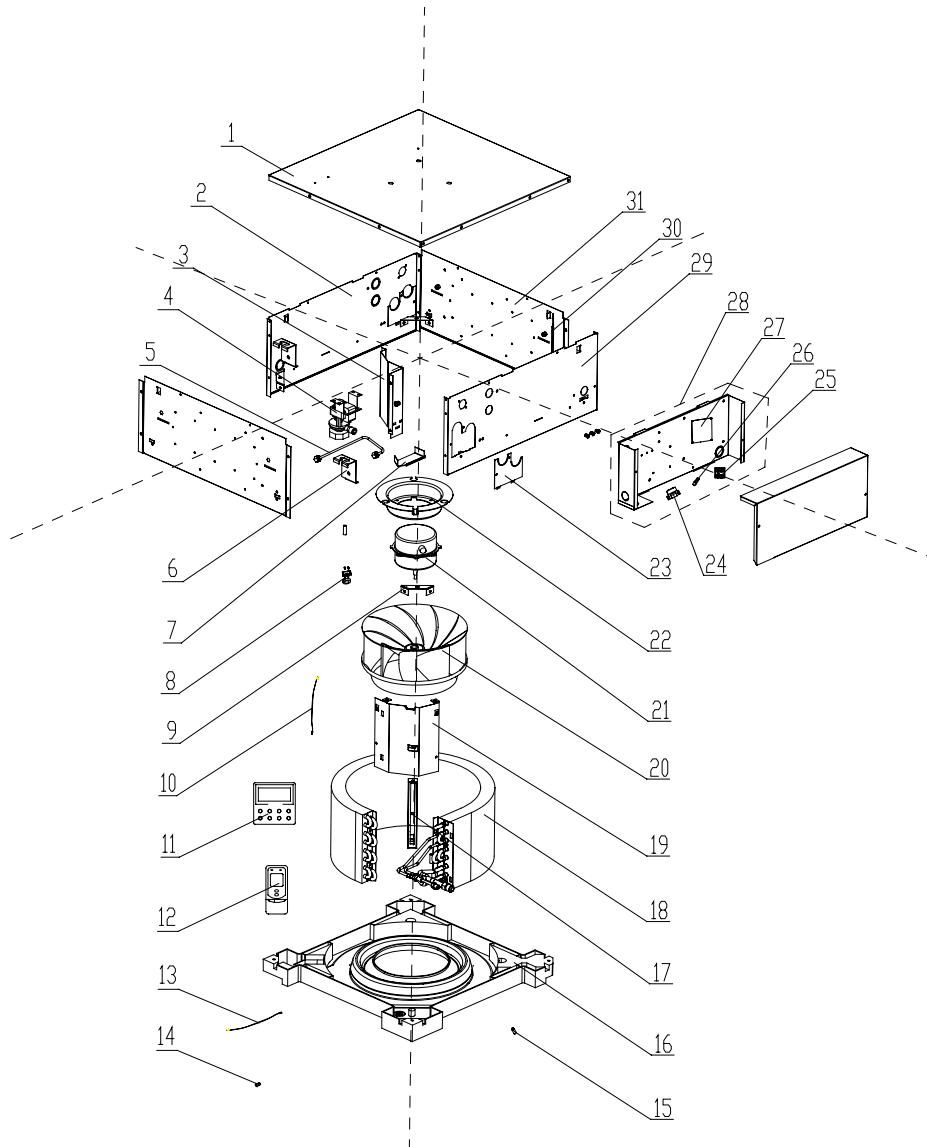



Part list: GKH(12)BA-K3DNA2A/I for CN510N0040

NO.	Description	GKH(12)BA-K3DNA2A/I	
		Code	Qty
1	Seat Board Sub-Assy	01222712	1
2	Front Side Plate	01302741	1
3	Right Baffle Assy	01362704	1
4	Water Pump	43130320	1
5	Pump Drainpipe	05232722	1
6	Body Installing Support	01332705	4
7	Pump Support Assy	01332708	1
8	Water Level Switch	450127011	1
9	Water Tray Support	01332706	4
10	Temperature Sensor	390001982G	1
11	Display Board	30296317	1
12	Remote Controller	305100492	1
13	Ambient Temperature Sensor	3900019813	1
14	Filter Sub-Assy	11120011	1
15	Filter Sub-Assy	11120012	1
16	Water Tray Assy	20182704	1
17	Evaporator Support	01072714	1
18	Evaporator Assy	01024307	1
19	Evaporator Connection Board	01072713	1
20	Centrifugal Fan	10312702	1
21	Fan Motor	15704114	1
22	Motor Support	01702702	1
23	Tube Exit Plate Assy	01382719	1
24	Transformer	43110226	1
25	Terminal Board	420111041	1
26	Capacitor	33010026	1
27	Main Board	30226354	1
28	Electric Box Assy	01399534	1
29	Front Side Plate	01314211	1
30	Pass WirePlate	01362701	1
31	Right Side Plate Sub-Assy	01302743	2

GKH(18)BA-K3DNA2A/I

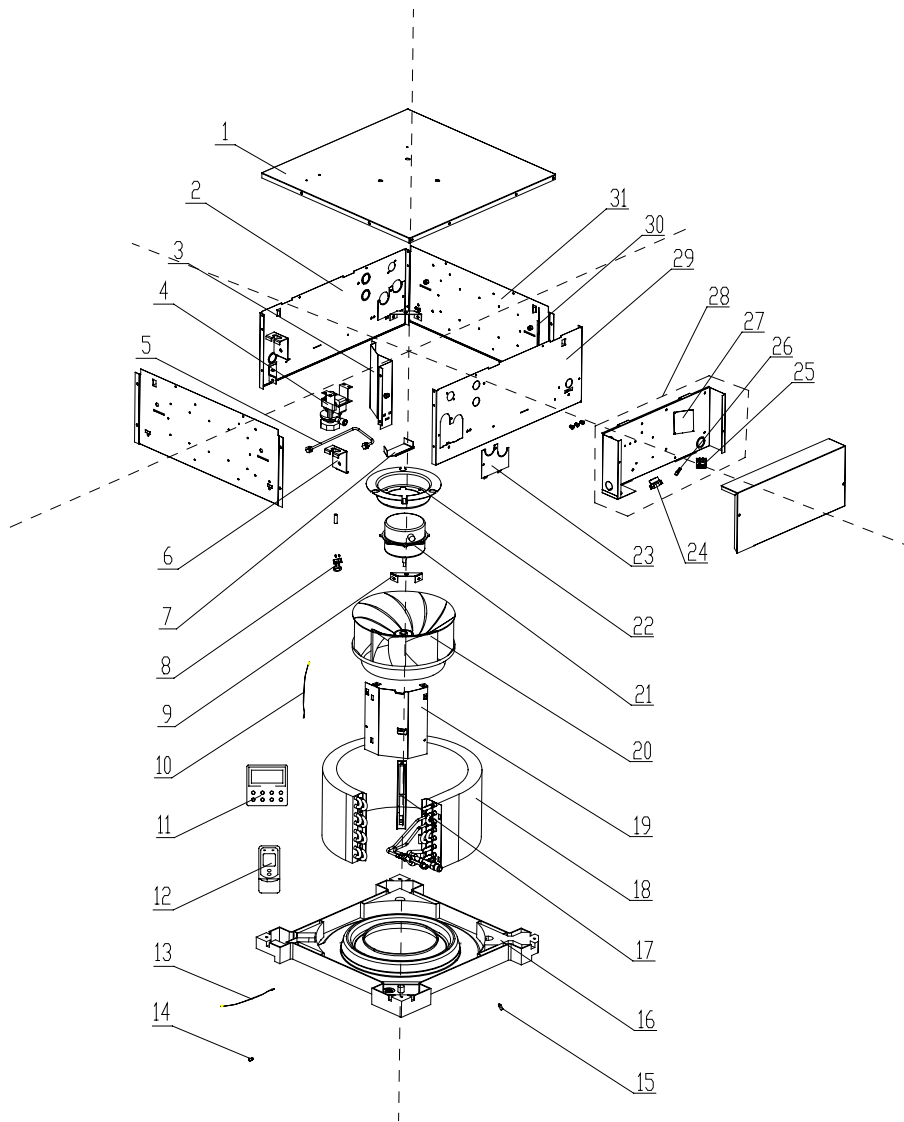



Part list: GKH(18)BA-K3DNA2A/I for CN510N0050

NO.	Description	GKH(18)BA-K3DNA2A/I	
		Code	Qty
1	Seat Board Sub-Assy	01222712	1
2	Front Side Plate	01302741	1
3	Right Baffle Assy	01362704	1
4	Water Pump	43130320	1
5	Pump Drainpipe	05232722	1
6	Body Installing Support	01332705	4
7	Pump Support Assy	'01332708	1
8	Water Level Switch	450127011	1
9	Water Tray Support	01332706	4
10	Temperature Sensor	390001982G	1
11	Display Board	30296317	1
12	Remote Controller	305100492	1
13	Ambient Temperature Sensor	3900019813	1
14	Filter Sub-Assy	11120011	1
15	Filter Sub-Assy	11128633	1
16	Water Tray Assy	20182704	1
17	Evaporator Support	01072714	1
18	Evaporator Assy	0102430701	1
19	Evaporator Connection Board	01072713	1
20	Centrifugal Fan	10312702	1
21	Fan Motor	15704114	1
22	Motor Support	01702702	1
23	Tube Exit Plate Assy	01382719	1
24	Transformer	43110226	1
25	Terminal Board	420111041	1
26	Capacitor	33010026	1
27	Main Board	30226354	1
28	Electric Box Assy	01399534	1
29	Front Side Plate	01314211	1
30	Pass WirePlate	01362701	1
31	Right Side Plate Sub-Assy	01302743	2

5.2.3 Floor ceiling type

GTH(09)BA-K3DNA1A/I

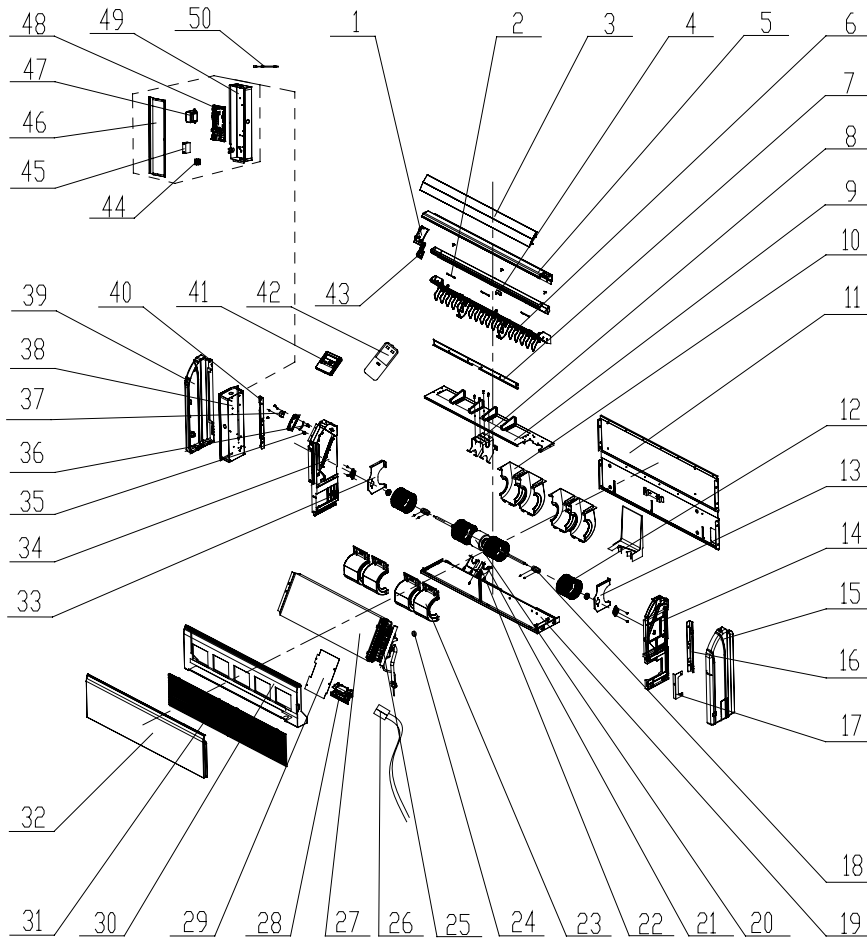

Part list: GTH(09)BA-K3DNA1A/I for CN610N0010

NO.	Description	GTH(09)BA-K3DNA1A/I	
		Code	Qty
1	Fixed Mount	26909426R	1
2	Louver Clamp	26112127	2
3	Guide Louver	10619403	1
4	Rotating Shaft	26909430	4
5	Front Connecting Plate	01349414P	1
6	Base Frame	26909448	1
7	Air Lead Plate sub-assy	02229418	1
8	Supporter	01805288	1
9	Mid-clapboard sub-assy	01249416	1
10	Front volute casing	26905205	4
11	Rear side plate assy	01319430	1
12	Centrifugal fan	10425200	4
13	Support 1	01809417	1
14	Right Side Plate Sub-Assy	01319429	1
15	Right Cover Plate	26909444	1
16	Installation Supporting Frame	01809402	1
17	Connection Board	02229406	1
18	Joint Slack	73018731	2
19	Rear Connecting Plate	01349416	1
20	Fan Motor	1570940901	1
21	Bar Clasp	70818405	1
22	Bar Clasp Sub-assy	70815201	1
23	Rear volute casing	26905206	4
24	Cable-Cross Loop	76510021	1
25	Filter 2	07216221	1
26	Sensor	3900020723	1
27	Evaporator Assy	01029482	1
28	Press Plate of Water Lead flume	26909442	1
29	Connection Board	01344115	1
30	Water Tray Assy	01289404	1
31	Front Grill sub-assy	01579403	1
32	Top Cover Board Sub-assy	01269409	1
33	Support 2	01809418	1
34	Left Side Plate Sub-Assy	0131942801	1
35	Rotating Shaft	26909412	1
36	Rotating Shaft	26909413	1
37	Step Motor	1521240206	1
38	Electric Box Assy	01399517	1
39	Left Cover Plate	26909443	1
40	Installation Supporting Frame	01809401	1
41	Display Board	30296317	1
42	Remote Controller	305100492	1
43	Display Board	30294220	1
44	Terminal Board	42010178	1
45	Capacitor CBB61	33010089	1
46	Electric Box Cover	01429420	1
47	Transformer	4311023701	1
48	Main Board	30226350	1
49	Electric Box	01429419	1
50	Room Sensor	39000191	1

GTH(12)BA-K3DNA1A/I

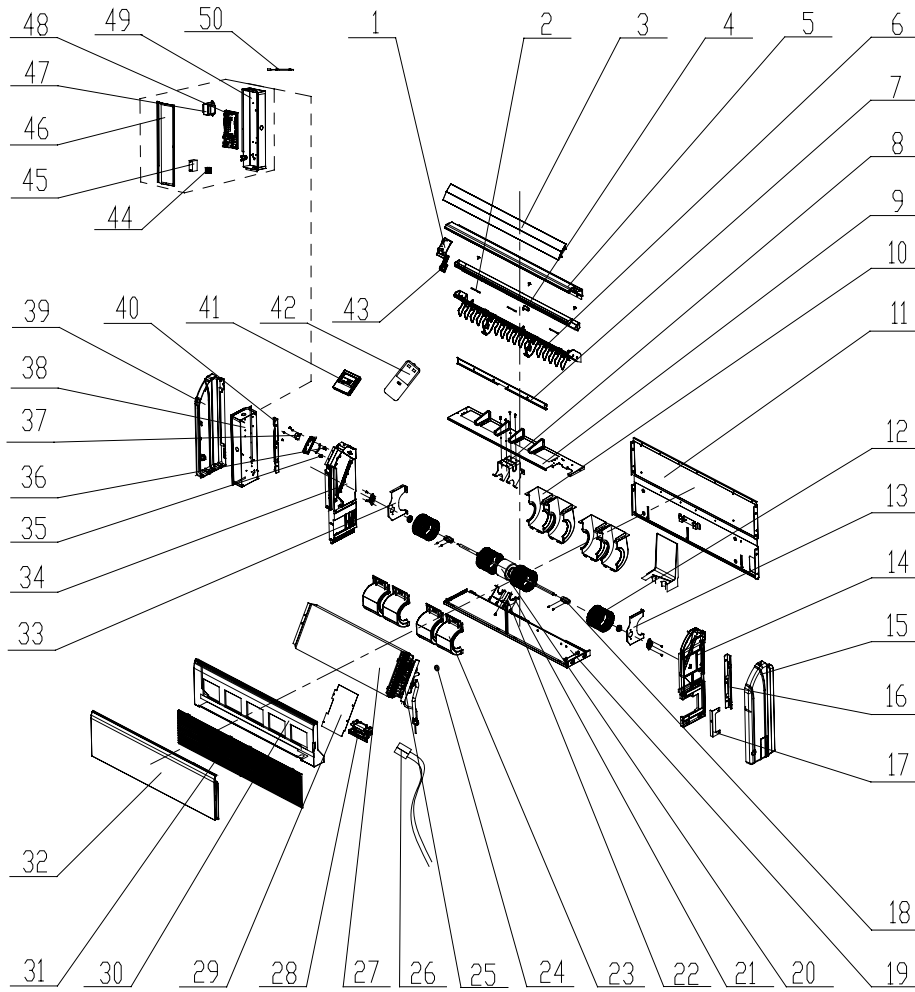

Part list: GTH(12)BA-K3DNA1A/I for CN610N0020

NO.	Description	GTH(12)BA-K3DNA1A/I	
		Code	Qty
1	Fixed Mount	26909426R	1
2	Louver Clamp	26112127	2
3	Guide Louver	10619403	1
4	Rotating Shaft	26909430	4
5	Front Connecting Plate	01349414P	1
6	Base Frame	26909448	1
7	Air Lead Plate sub-assy	02229418	1
8	Supporter	01805288	1
9	Mid-clapboard sub-assy	01249416	1
10	Front volute casing	26905205	4
11	Rear side plate assy	01319430	1
12	Centrifugal fan	10425200	4
13	Support 1	01809417	1
14	Right Side Plate Sub-Assy	01319429	1
15	Right Cover Plate	26909444	1
16	Installation Supporting Frame	01809402	1
17	Connection Board	02229406	1
18	Joint Slack	73018731	2
19	Rear Connecting Plate	01349416	1
20	Fan Motor	1570940901	1
21	Bar Clasp	70818405	1
22	Bar Clasp Sub-assy	70815201	1
23	Rear volute casing	26905206	4
24	Cable-Cross Loop	76510021	1
25	Filter 2	07216221	1
26	Sensor	3900020723	1
27	Evaporator Assy	01029475	1
28	Press Plate of Water Lead flume	26909442	1
29	Connection Board	01344115	1
30	Water Tray Assy	01289404	1
31	Front Grill sub-assy	01579403	1
32	Top Cover Board Sub-assy	01269409	1
33	Support 2	01809418	1
34	Left Side Plate Sub-Assy	0131942801	1
35	Rotating Shaft	26909412	1
36	Rotating Shaft	26909413	1
37	Step Motor	1521240206	1
38	Electric Box Assy	01399517	1
39	Left Cover Plate	26909443	1
40	Installation Supporting Frame	01809401	1
41	Display Board	30296317	1
42	Remote Controller	305100492	1
43	Display Board	30294220	1
44	Terminal Board	42010178	1
45	Capacitor CBB61	33010089	1
46	Electric Box Cover	01429420	1
47	Transformer	4311023701	1
48	Main Board	30226350	1
49	Electric Box	01429419	1
50	Room Sensor	39000191	1

GTH(18)BA-K3DNA1A/I

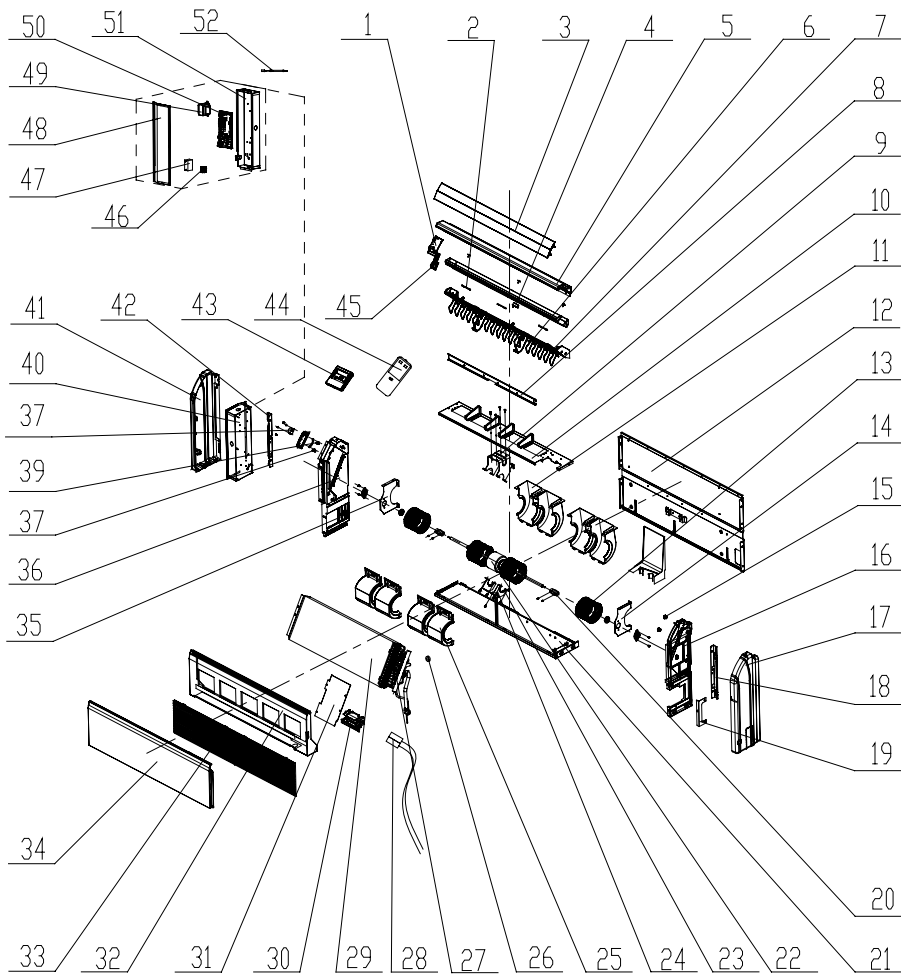

Part list: GTH(18)BA-K3DNA1A/I for CN610N0030

NO.	Description	GTH(18)BA-K3DNA1A/I	
		Code	Qty
1	Fixed Mount	26909426R	1
2	Louver Clamp	26112127	2
3	Guide Louver	10619403	1
4	Rotating Shaft	26909430	4
5	Front Connecting Plate	01349414P	1
6	Air Louver	10619404	16
7	Base Frame	26909448	1
8	Air Lead Plate sub-assy	02229418	1
9	Supporter	01805288	1
10	Mid-clapboard sub-assy	01249416	1
11	Front volute casing	26905205	4
12	Rear side plate assy	01319430	1
13	Centrifugal fan	10425200	4
14	Support 1	01809417	1
15	Axile Bush	10542704	2
16	Right Side Plate Sub-Assy	01319429	1
17	Right Cover Plate	26909444	1
18	Installation Supporting Frame	01809402	1
19	Connection Board	02229406	1
20	Joint Slack	73018731	2
21	Rear Connecting Plate	01349416	1
22	Fan Motor	1570940901	1
23	Bar Clasp	70818405	1
24	Bar Clasp Sub-assy	70815201	1
25	Rear volute casing	26905206	4
26	Cable-Cross Loop	76510021	1
27	Filter 2	07216221	1
28	Sensor	3900020723	1
29	Evaporator Assy	01029469	1
30	Press Plate of Water Lead flume	26909442	1
31	Connection Board	01344115	1
32	Water Tray Assy	01289404	1
33	Front Grill sub-assy	01579403	1
34	Top Cover Board Sub-assy	01269409	1
35	Support 2	01809418	1
36	Left Side Plate Sub-Assy	0131942801	1
37	Rotating Shaft	26909412	1
38	Rotating Shaft	26909413	1
39	Step Motor	1521240206	1
40	Electric Box Assy	01399511	1
41	Left Cover Plate	26909443	1
42	Installation Supporting Frame	01809401	1
43	Display Board	30296317	1
44	Remote Controller	305100492	1
45	Display Board	30294220	1
46	Terminal Board	42010178	1
47	Capacitor CBB61	33010026	1
48	Electric Box Cover	01429420	1
49	Transformer	4311023701	1
50	Main Board	30226350	1
51	Electric Box	01429419	1
52	Room Sensor	39000191	1

GTH(24)BA-K3DNA1A/I

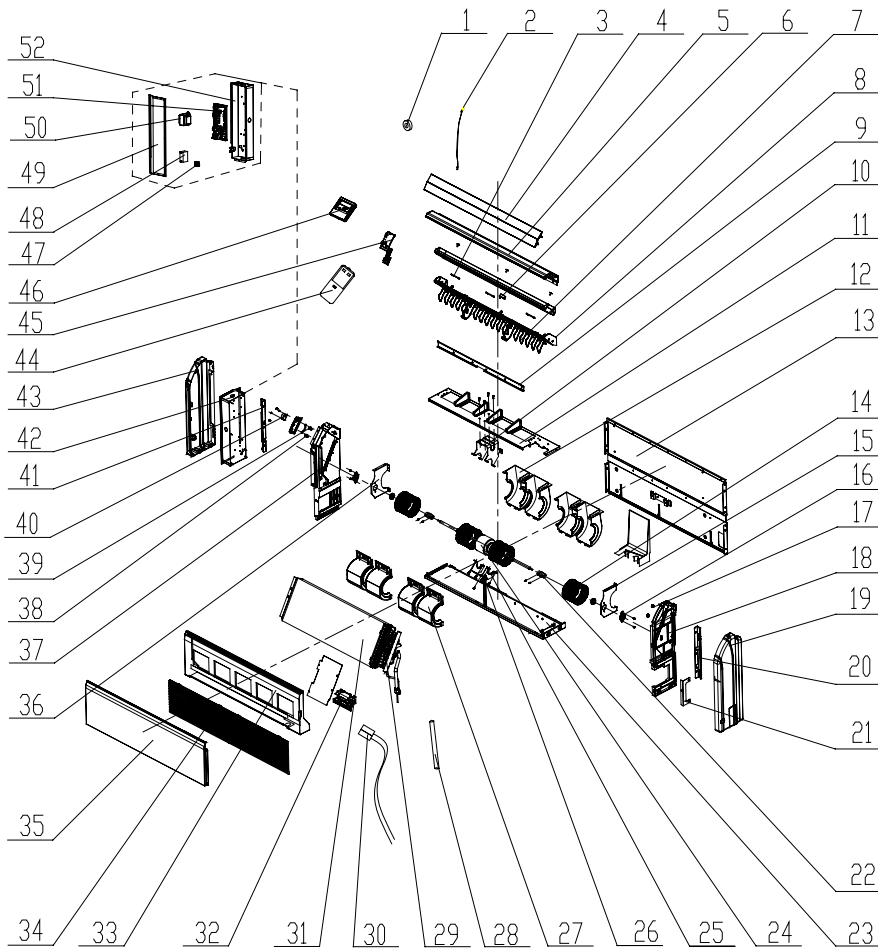

Part list: GTH(18)BA-K3DNA1A/I for CN610N0040

NO.	Description	GTH(24)BA-K3DNA1A/I	
		Code	Qty
1	Cable-Cross Loop	76510021	4
2	Room Sensor	39000191	1
3	Louver Clamp	26112127	2
4	Guide Louver	10619403	2
5	Front Connecting Plate	01349414P	1
6	Rotating Shaft	26909340	4
7	Air Louver	10699404	16
8	Base Frame	26909448	1
9	Induced air plate subassembly	02229418	1
10	Supporter	01805288	1
11	Mid-clapboard sub-assy	01249416	1
12	Front volute casing	26905205	4
13	Rear side plate assy	01319430	1
14	Centrifugal fan	10425200	4
15	Supporter	01809417	1
16	Support Of Motor Bearing	01792408	2
17	Axile Bush	10542704	2
18	Right Side Plate Sub-Assy	01319429	1
19	Right Cover Plate	26909444	1
20	Installation Supporting Frame	01809402	1
21	Connection Board	02229406	1
22	Joint Slack	73018731	2
23	Rear Connecting Plate	01349416	1
24	Fan Motor	15709409	1
25	Bar Clasp	70818405	1
26	Hoop subassembly	70815201	1
27	Rear volute casing	26905205	4
28	Drainage Pipe Sub-assy	05235434	1
29	Filter	07212001	1
30	Temperature Sensor	3900020723	1
31	Evaporator Assy	01029474	1
32	Press Plate of Water Lead flume	26909442	1
33	Water Tray Assy	01289404	1
34	Front Grill sub-assy	01579403	2
35	Top Cover Board Sub-assy	01269409	1
36	Supporter	01809418	1
37	Left Side Plate Sub-Assy	0131942801	1
38	Rotating Shaft	296909412	1
39	Rotating Shaft	12690941	3
40	Step Motor	1152124020	6
41	Installation Supporting Frame	01809401	1
42	Electric Box Assy	01399518	1
43	Left Cover Plate	26909443	1
44	Remote Controller	305100492	1
45	Display Board	30294220	1
46	Display Board	30296317	1
47	Terminal Board	42010178	1
48	Capacitor CBB61	33010027	1
49	Electric Box Cover	01429420	1
50	Transformer	4311023701	1
51	Main Board	30226350	1
52	Electric Box	01429419	1



Add: West Jinji Rd, Qianshan, Zhuhai 519070, Guangdong, China

Tel: (+86-756) 8522218 Fax: (+86-756) 8669426

Email: gree@gree.com.cn

<http://www.gree.com>

For continuous improvement in the products, Gree reserves the right to modify the product specification and appearance in this manual without notice and without incurring any obligations.

JF00300945