

Service Manual

MODEL: GWHD(14)NK3BO
GWHD(18)NK3DO
GWHD(24)NK3DO
GWHD(24)NK3EO
GWHD(28)NK3BO
(Refrigerant R410A)

Table of Contents

Summary and features	1
1. Safety Precautions	2
2. Specifications	3
3. Construction Views	5
4. Refrigerant System Diagram	6
5. Schematic Diagram	7
5.1 Electrical Data	7
5.2 Electrical Wiring	7
5.3 Printed Circuit Board	10
6. Description of Each Control Operation	13
7. Installation Manual	16
7.1 Electrical Connections	16
7.2 Installing the Outdoor Unit	19
7.3 Installation Dimension Diagram	20
7.4 Check after Installation	21
8. Exploded Views and Parts List	22
9. Troubleshooting	36
9.1 Malfunction Indicator	36
9.2 Malfunction Checking and Elimination	37
10. Removal Procedure	51

Summary and features

Outdoor Unit:

GWHD(14)NK3BO
GWHD(18)NK3DO

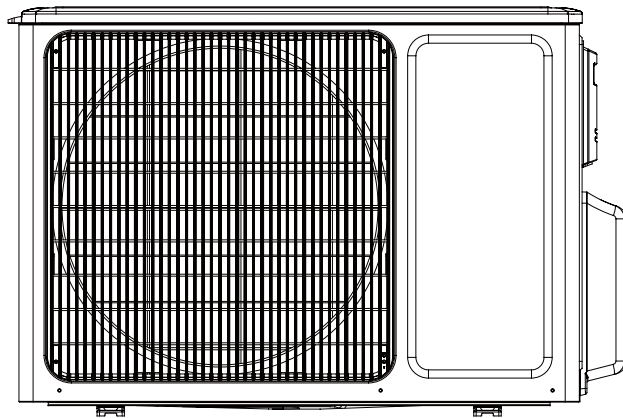

GWHD(24)NK3DO
GWHD(24)NK3EO
GWHD(28)NK3BO

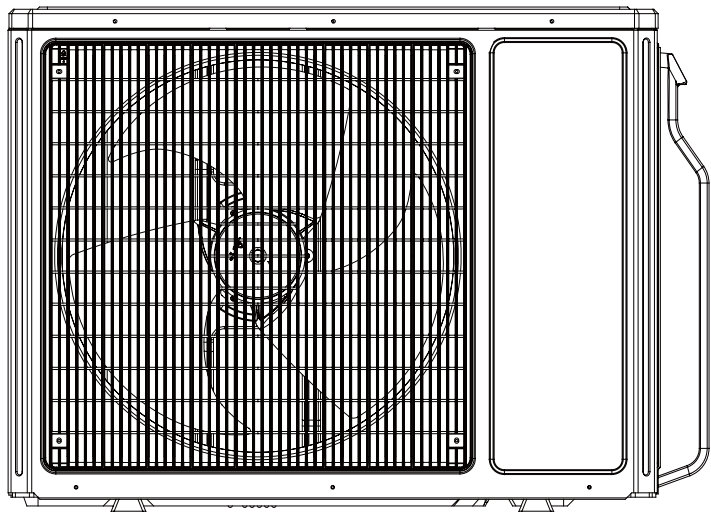

1. Safety Precautions



Installing, starting up, and servicing air conditioner can be hazardous due to system pressure, electrical components, and equipment location, etc.

Only trained, qualified installers and service personnel are allowed to install, start-up, and service this equipment. Untrained personnel can perform basic maintenance functions such as cleaning coils. All other operations should be performed by trained service personnel.

When handling the equipment, observe precautions in the manual and on tags, stickers, and labels attached to the equipment. Follow all safety codes. Wear safety glasses and work gloves. Keep quenching cloth and fire extinguisher nearby when brazing.

Read the instructions thoroughly and follow all warnings or cautions in literature and attached to the unit. Consult local building codes and current editions of national as well as local electrical codes.

Recognize the following safety information:

-  **Warning** Incorrect handling could result in personal injury or death.
-  **Caution** Incorrect handling may result in minor injury, or damage to product or property.

- Make sure the outdoor unit is installed on a stable, level surface with no accumulation of snow, leaves, or trash beside.
- Make sure the ceiling/wall is strong enough to bear the weight of the unit.
- Make sure the noise of the outdoor unit does not disturb neighbors.
- Follow all the installation instructions to minimize the risk of damage from earthquakes, typhoons or strong winds.
- Avoid contact between refrigerant and fire as it generates poisonous gas.
- Apply specified refrigerant only. Never have it mixed with any other refrigerant. Never have air remain in the refrigerant line as it may lead to rupture and other hazards.
- Make sure no refrigerant gas is leaking out when installation is completed.
- Should there be refrigerant leakage, the density of refrigerant in the air shall in no way exceed its limited value, or it may lead to explosion.
- Keep your fingers and clothing away from any moving parts.
- Clear the site after installation. Make sure no foreign objects are left in the unit.
- Always ensure effective grounding for the unit.

Warning

All electric work must be performed by a licensed technician according to local regulations and the instructions given in this manual.

- Before installing, modifying, or servicing system, main electrical disconnect switch must be in the OFF position. There may be more than 1 disconnect switch. Lock out and tag switch with a suitable warning label.
- Never supply power to the unit unless all wiring and tubing are completed, reconnected and checked.
- This system adopts highly dangerous electrical voltage. Incorrect connection or inadequate grounding can cause personal injury or death. Stick to the wiring diagram and all the instructions when wiring.
- Have the unit adequately grounded in accordance with local electrical codes.
- Have all wiring connected tightly. Loose connection may lead to overheating and a possible fire hazard.

All installation or repair work shall be performed by your dealer or a specialized subcontractor as there is the risk of fire, electric shock, explosion or injury.

Caution

- Never install the unit in a place where a combustible gas might leak, or it may lead to fire or explosion.
- Make a proper provision against noise when the unit is installed at a telecommunication center or hospital.
- Provide an electric leak breaker when it is installed in a watery place.
- Never wash the unit with water.
- Handle unit transportation with care. The unit should not be carried by only one person if it is more than 20kg.
- Never touch the heat exchanger fins with bare hands.
- Never touch the compressor or refrigerant piping without wearing glove.
- Do not have the unit operate without air filter.
- Should any emergency occur, stop the unit and disconnect the power immediately.
- Properly insulate any tubing running inside the room to prevent the water from damaging the wall.

2. Specifications

Model	GWHD(14)NK3BO	GWHD(18)NK3DO
Product Code	CB228W0120	CB228W0080
Compressor Manufacturer/trademark	Shenyang SANYO	Shenyang SANYO
Compressor Model	C-6RZ146H1A	C-6RZ146H1A
Compressor Oil	FV50S	FV50S
Compressor Type	Rotary	Rotary
L.R.A. (A)	32	32
Compressor RLA(A)	4.54	4.54
Compressor Power Input(W)	1000	1000
Overload Protector	1NT11L-3979	1NT11L-3979
Throttling Method	Electronic Expansion Valve	Electronic Expansion Valve
Starting Method	Transducer starting	Transducer starting
Cooling Working Temp Range (°C)	-5 ≤ T ≤ 43	-5 ≤ T ≤ 43
Heating Working Temp Range (°C)	-10 ≤ T ≤ 24	-10 ≤ T ≤ 24
Condenser	Aluminum fin-copper tube	Aluminum fin-copper tube
Pipe Diameter	Φ9.52	Φ9.52
Rows-Fin Gap(mm)	2-1.4	2-1.4
Coil length (l) X height (H) X coil width (L)	800X559X44	800X559X44
Fan Motor Speed (rpm) (H/M/L)	880/700/500	880/700/500
Output of Fan Motor (W)	60	60
Fan Motor RLA(A)	0.56	0.56
Fan Motor Capacitor (uF)	4	4
Air Flow Volume of Outdoor Unit	2600/2300/1600	2600/2300/1600
Fan Type	Axial fan	Axial fan
Fan Diameter (mm)	Φ445	Φ445
Defrosting Method	Automatic Defrosting	Automatic Defrosting
Climate Type	T1	T1
Isolation	I	I
Moisture Protection	IP24	IP24
Permissible Excessive Operating Pressure for the Discharge Side(MPa)	3.8	3.8
Permissible Excessive Operating Pressure for the Suction Side(MPa)	1.2	1.2
Sound Pressure Level dB (A) (H/M/L)	56/53/50	56/53/50
Sound Power Level dB (A) (H/M/L)	66/63/60	66/63/60
Dimension (W/H/D) (mm)	903/596/378	903/596/378
Dimension of Package (L/W/H)(mm)	948X420X645	948X420X645
Net Weight /Gross Weight (kg)	43/48	43/48
Refrigerant Charge (kg)	R410A/1.40	R410A/1.40

The above data is subject to change without notice. Please refer to the nameplate of the unit.

Model	GWHD(24)NK3DO	GWHD(24)NK3EO	GWHD(28)NK3BO
Product Code	CB228W0070	CB228W0100	CB228W0110
	CB228W0071	CB228W0101	CB228W0111
Compressor Manufacturer/trademark	MITSUBISHI ELECTRIC (GUANGZHOU)COMPRESSOR CO. LTD		
Compressor Model	TNB220FLHMC	TNB220FLHMC	TNB220FLHMC
Compressor Oil	FV50S	FV50S	FV50S
Compressor Type	Rotary	Rotary	Rotary
L.R.A. (A)	45	45	45
Compressor RLA(A)	9.7	9.7	9.7
Compressor Power Input(W)	2200	2200	2200
Overload Protector	CS-7C-1595	CS-7C-1595	CS-7C-1595
Throttling Method	Electronic Expansion Valve	Electronic Expansion Valve	Electronic Expansion Valve
Starting Method	Transducer starting	Transducer starting	Transducer starting
Cooling Working Temp Range (°C)	-5 ≤ T ≤ 43	-5 ≤ T ≤ 43	-5 ≤ T ≤ 43
Heating Working Temp Range (°C)	-10 ≤ T ≤ 24	-10 ≤ T ≤ 24	-10 ≤ T ≤ 24
Condenser	Aluminum fin-copper tube	Aluminum fin-copper tube	Aluminum fin-copper tube
Pipe Diameter	Φ9.52	Φ9.52	Φ9.52
Rows-Fin Gap(mm)	2-1.4	2-1.4	2-1.4
Coil length (l) X height (H) X coil width (L)	890X660X44	890X660X44	890X660X44
Fan Motor Speed (rpm) (H/M/L)	690/600/500	690/600/500	690/600/500
Output of Fan Motor (W)	60	60	60
Fan Motor RLA(A)	0.6	0.6	0.6
Fan Motor Capacitor (uF)	3.5	3.5	3.5
Air Flow Volume of Outdoor Unit	3300/2900/2400	3300/2900/2400	3300/2900/2400
Fan Type	Axial fan	Axial fan	Axial fan
Fan Diameter (mm)	Φ520	Φ520	Φ520
Defrosting Method	Automatic Defrosting	Automatic Defrosting	Automatic Defrosting
Climate Type	T1	T1	T1
Isolation	I	I	I
Moisture Protection	IP24	IP24	IP24
Permissible Excessive Operating Pressure for the Discharge Side(MPa)	3.8	3.8	3.8
Permissible Excessive Operating Pressure for the Suction Side(MPa)	1.2	1.2	1.2
Sound Pressure Level dB (A) (H/M/L)	58/54/52	58/54/52	59/56/53
Sound Power Level dB (A) (H/M/L)	68/64/62	68/64/62	69/66/63
Dimension (W/H/D) (mm)	963X700X396	963X700X396	963X700X396
Dimension of Package (L/W/H)(mm)	1026X458X750	1026X458X750	1026X458X750
Net Weight /Gross Weight (kg)	59/64	59/64	60/65
Refrigerant Charge (kg)	R410A/2.4	R410A/2.2	R410A/2.2

The above data is subject to change without notice. Please refer to the nameplate of the unit.

3. Construction Views

Models:GWHD(14)NK3BO,GWHD(18)NK3DO

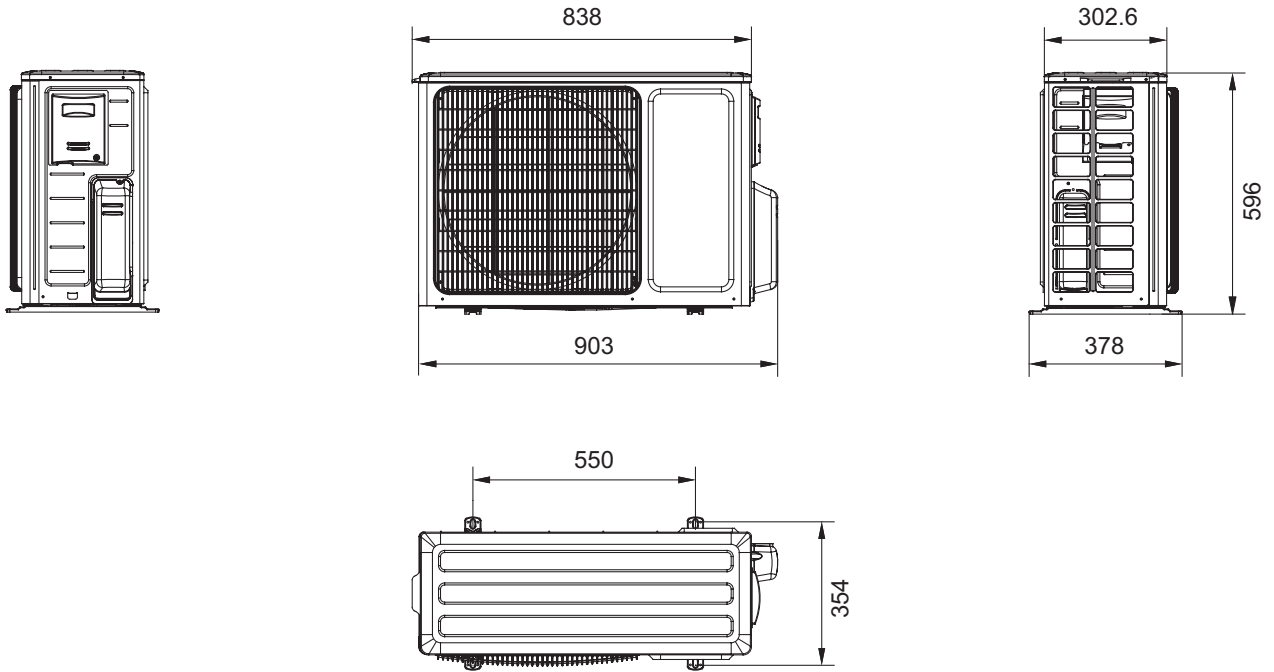

Models:GWHD(24)NK3DO,GWHD(24)NK3EO,GWHD(28)NK3BO

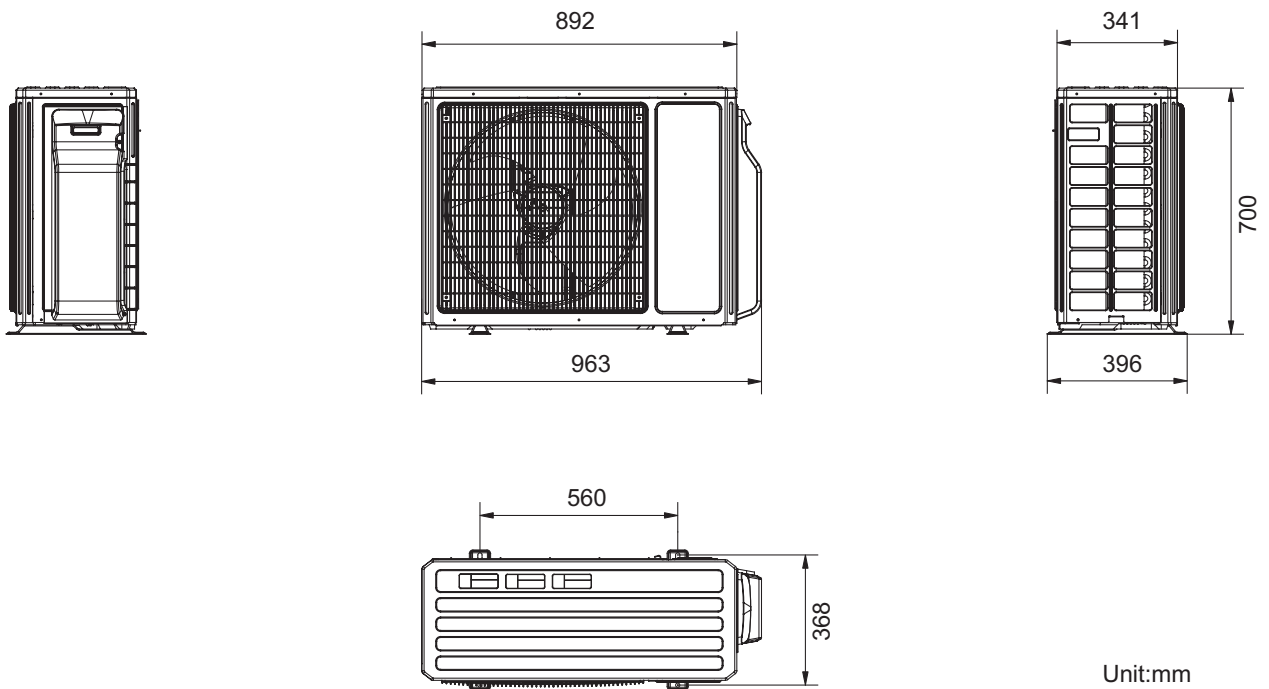

Unit:mm

4. Refrigerant System Diagram

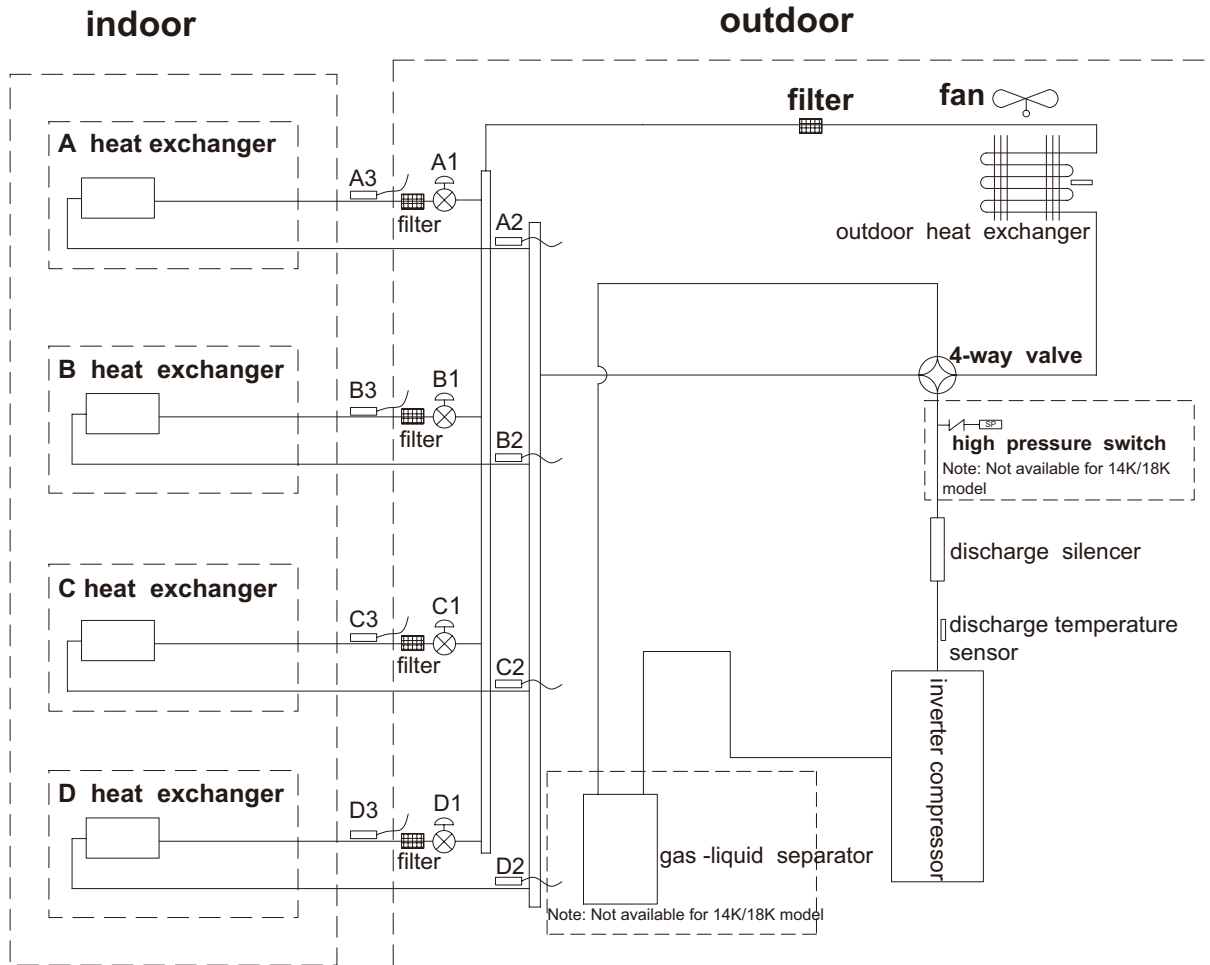

- A1:A-unit electronic expansion valve B1:B-unit electronic expansion valve**
- C1:C-unit electronic expansion valve D1:D-unit electronic expansion valve**
- A2:A-unit gas pipe temperature sensor B2:B-unit gas pipe temperature sensor**
- C2:C-unit gas pipe temperature sensor D2:D-unit gas pipe temperature sensor**
- A3:A-unit liquid pipe temperature sensor B3:B-unit liquid pipe temperature sensor**
- C3:C-unit liquid pipe temperature sensor D3:D-unit liquid pipe temperature sensor**

5. Schematic Diagram

5.1 Electrical Data

Meaning of marks

Symbol	Color symbol	Symbol	Color symbol	Symbol	Parts name
WH	WHITE	GN	GREEN	SAT	OVERLOAD
YE	YELLOW	BN	BROWN	COMP	COMPRESSOR
RD	RED	BU	BLUE		PROTECTIVE EARTH
YEGN	YELLOW GREEN	BK	BLACK	/	/
VT	VIOLET	OG	ORANGE	/	/

5.2 Electrical Wiring

(1) Models: GWHD(14)NK3BO, GWHD(18)NK3DO

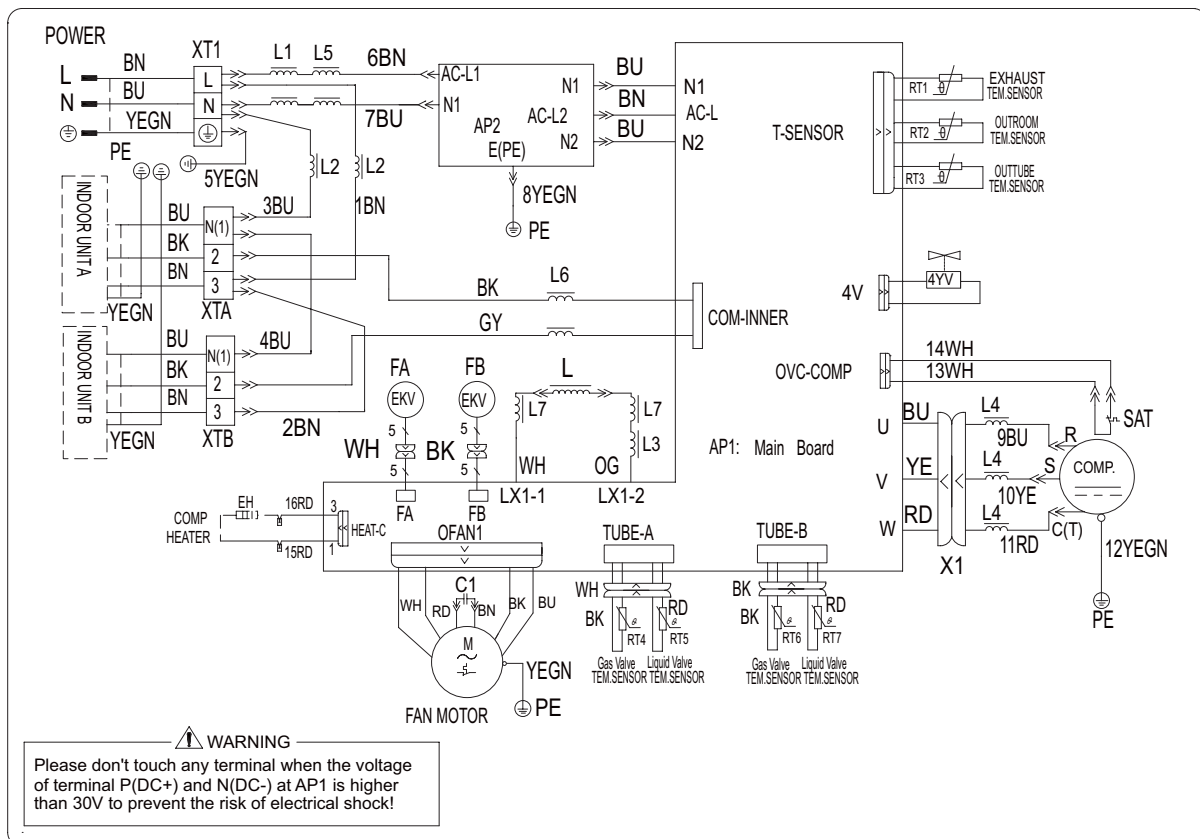

(2) Model: GWHD(24)NK3DO(CB228W0071)

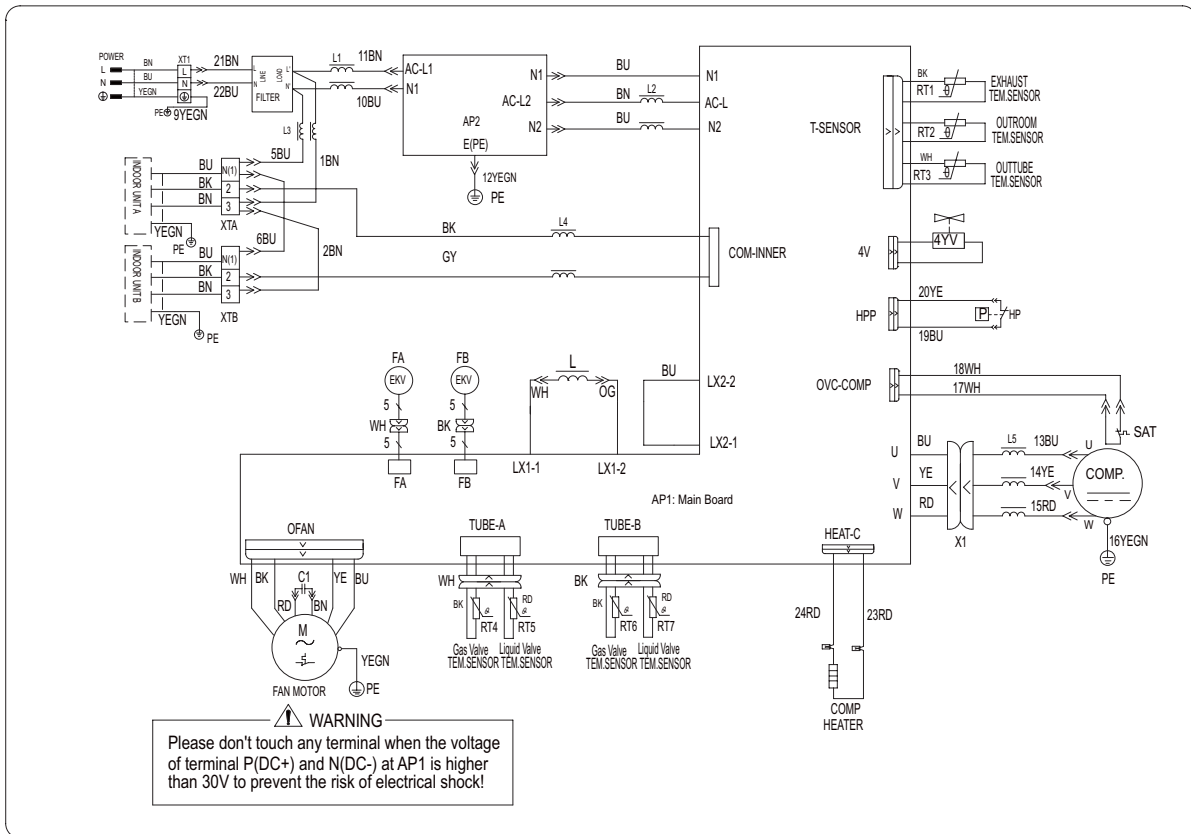

(3) Models: GWHD(24)NK3DO(CB228W0070) GWHD(24)NK3EO

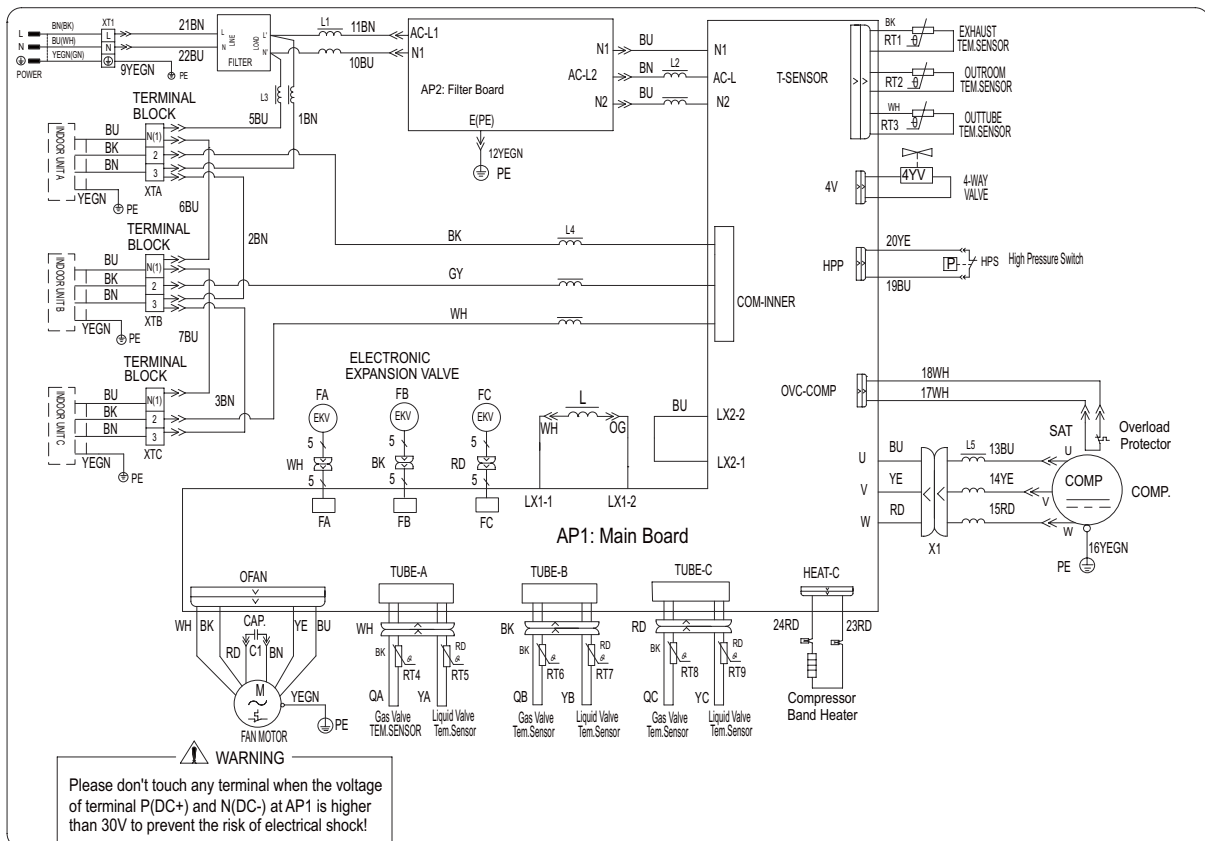

(4) Model: GWHD(28)NK3BO

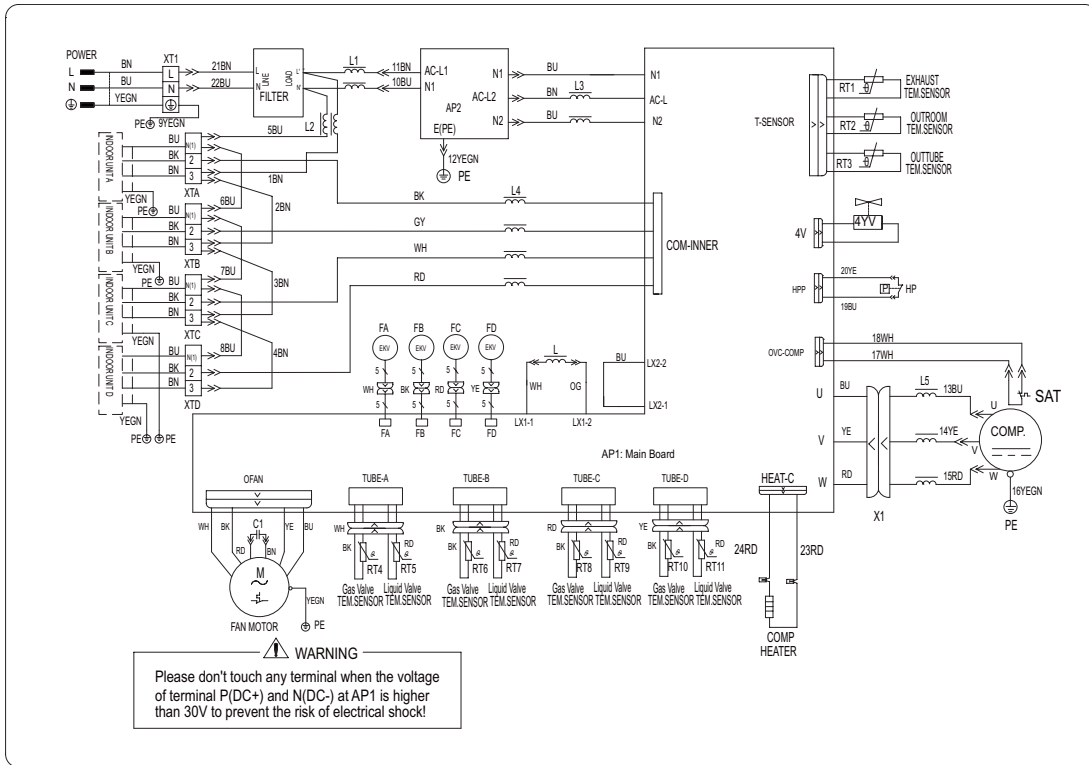

These circuit diagrams are subject to change without notice, please refer to the one supplied with the unit.

(2) Models:GWHD(24)NK3DO(CB228W0070),GWHD(24)NK3EO(CB228W0100),GWHD(28)NK3BO(CB228W0110)

• TOP VIEW

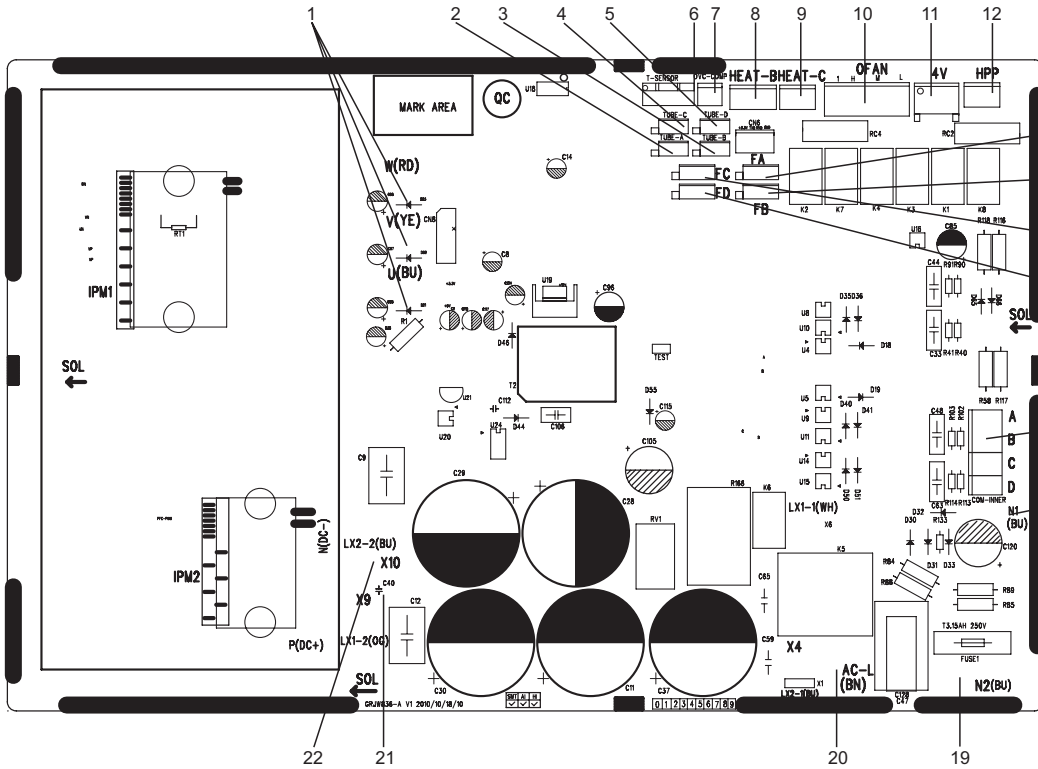

1	Compressor interface
2	Temperature sensor interface of unit A liquid valve and gas valve
3	Temperature sensor interface of unit B liquid valve and gas valve
4	Temperature sensor interface of unit C liquid valve and gas valve
5	Temperature sensor interface of unit D liquid valve and gas valve
6	Temperature sensor interface
7	Interface of compressor overload protector
8	Interface of chassis electric heater
9	Interface of compressor electric heater belt
10	Outdoor fan interface
11	4-way valve interface
12	High voltage protection interface
13	Interface of electronic expansion valve A
14	Interface of electronic expansion valve B
15	Interface of electronic expansion valve C
16	Interface of electronic expansion valve D
17	Communication wire interface
18	Communication neutral wire interface
19	Input neutral wire interface
20	Input live wire interface
21	PFC input live wire interface
22	PFC input neutral wire interface

• BOTTOM VIEW

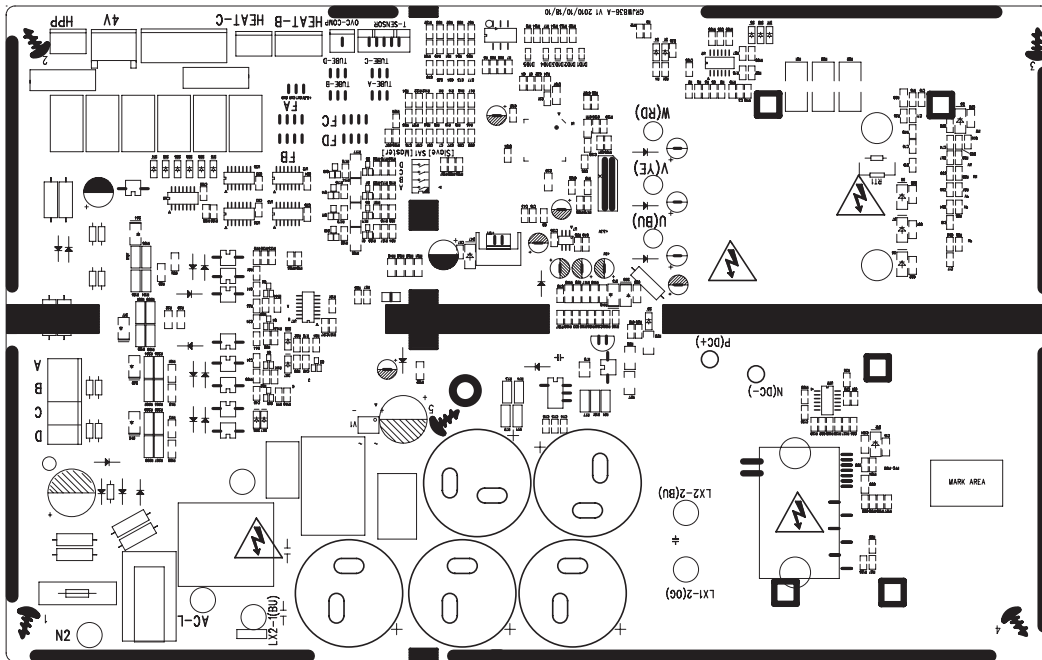

(3) Models:GWHD(24)NK3DO(CB228W0071),GWHD(24)NK3EO(CB228W0101),GWHD(28)NK3BO(CB228W0111)

• TOP VIEW

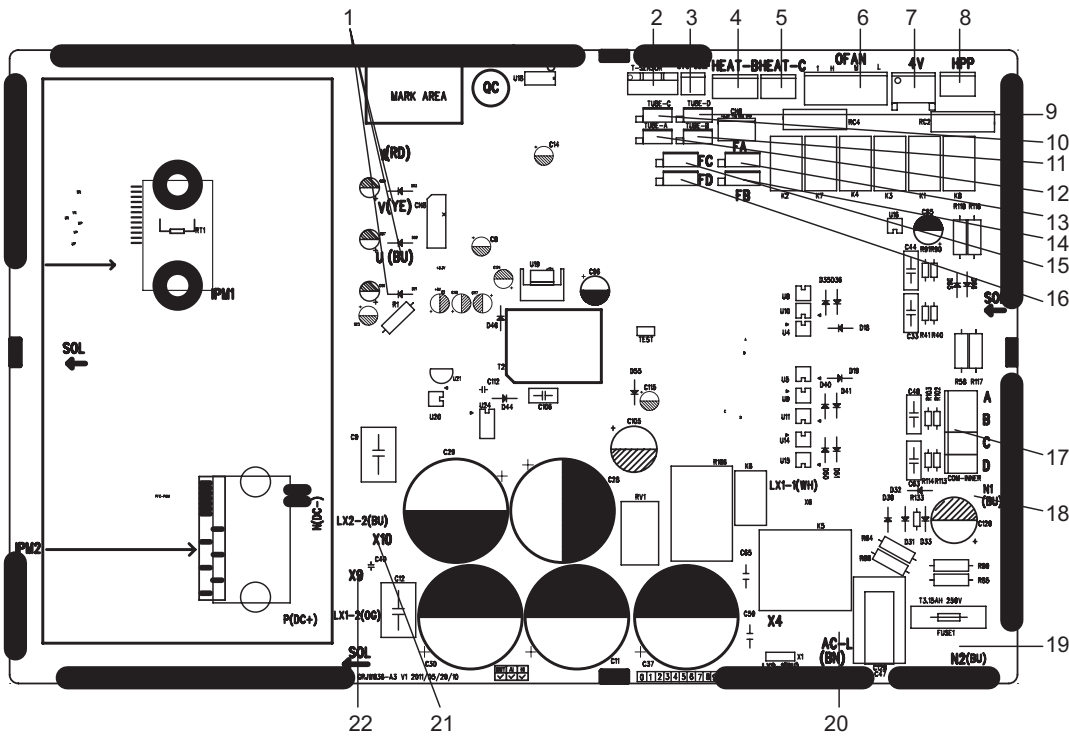

1	Interface of compressor
2	Interface of temperature sensor
3	Overload interface of compressor
4	Interface of electric heating tape for chassis
5	Interface of electric heating tape for compressor
6	Interface of outdoor unit
7	Interface of 4-way valve
8	Interface of high-pressure protection
9	Interface of temperature sensor for liquid valve and gas valve (unit D)
10	Interface of temperature sensor for liquid valve and gas valve (unit C)
11	Interface of temperature sensor for liquid valve and gas valve (unit B)
12	Interface of temperature sensor for liquid valve and gas valve (unit A)
13	Interface A pf electronic expansion valve
14	Interface B pf electronic expansion valve
15	Interface B pf electronic expansion valve
16	Interface D pf electronic expansion valve
17	Interface of communication wire
18	Interface of neutral wire for communication
19	Interface of input neutral wire
20	Interface of input live wire
21	Interface of PFC input neutral wire
22	Interface of PFC input live wire

• BOTTOM VIEW

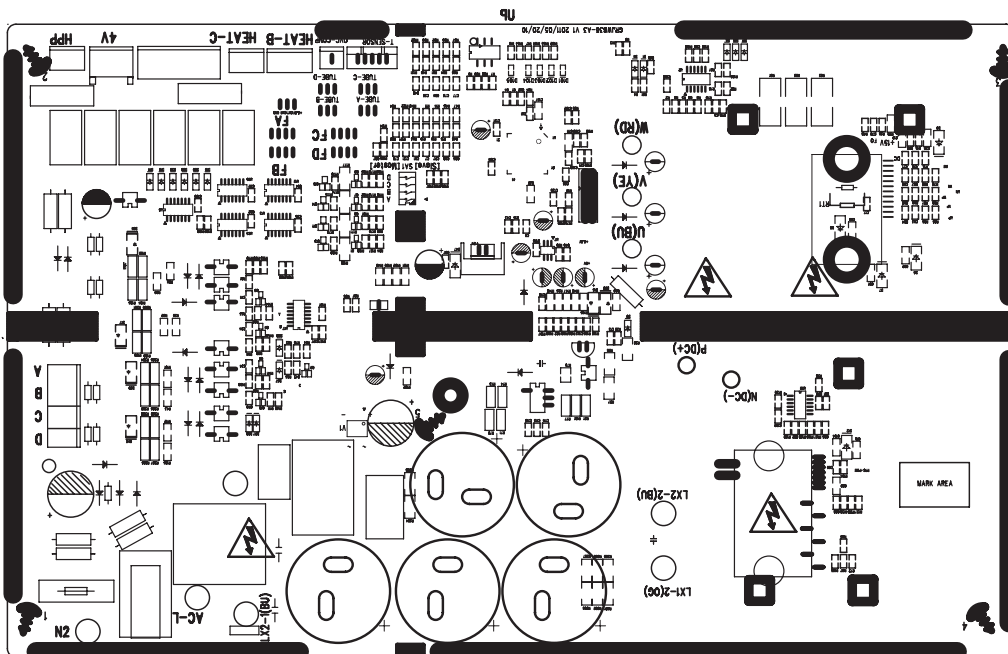

6. Description of Each Control Operation

1 Basic functions of the system

1.1 Cooling Mode

1.1.1 Cooling conditions and process:

If the compressor is in stop status and start the unit for cooling operation, when one of the indoor units reaches the cooling operation condition, the unit start cooling operation; in this case, the electronic expansion valve, the outdoor fan and the compressor start operation.

1.1.2 Stop in cooling operation

1.1.2.1 Compressor stops

The compressor stops immediately, the outdoor fan stops after 1min.

1.1.2.2 Some of the indoor units reach the stop condition (the compressor does not stop)

The compressor operates immediately according to the required frequency. For the indoor unit with no requirement, the corresponding electronic expansion valve is closed to OP.

1.1.3 Cooling mode transfers to heating mode

When the unit transfers to heating mode, the 4-way valve is energized after the compressor stops for 2min. The other disposals are the same as stopping in cooling mode.

1.1.4 4-way valve: in this mode, the 4-way valve is closed.

1.1.5 Outdoor fan control in cooling mode

The outdoor fan starts before 5s of the starting of compressor. The outdoor fan will run in high speed for 3min after starting and then it will run in set speed. The fan shall run at every speed for at least 80s. (When the quantity of running indoor unit is changed, the unit will enter the control described in 1.3.5.1 and 1.3.5.2);

When the compressor stops, the outdoor fan runs at present speed and stops after 1min.

1.2 Dry Mode

1.2.1 The dry conditions and process are the same as those in cooling mode;

1.2.2 The status of 4-way valve: closed;

1.2.3 The temperature setting range: 16 ~ 30°C;

1.2.4 Protection function: the same as those in cooling mode;

1.2.5 In dry mode, the maximum value A of the capacity requirement percentage of single unit is 90% of that in cooling mode.

The open condition of the electronic expansion valve, outdoor fan and compressor is the same as those in cooling mode.

1.3 Heating Mode

1.3.1 Cooling conditions and process:

When one of the indoor units reaches the heating operation condition, the unit starts heating operation.

1.3.2 Stop in heating operation:

1.3.2.1 When all the indoor units reach the stop condition, the compressor stops and the outdoor fan stops after 1min;

1.3.2.2 Some of the indoor units reach the stop condition

The compressor reduces the frequency immediately and operates according to the required frequency;

1.3.2.3 Heating mode transfers to cooling mode(dry mode), fan mode

a. The compressor stops; b. the power of 4-way valve is cut off after 2min; c. the outdoor fan stops after 1min; d. the status of 4-way valve: energized;

1.3.3 Outdoor fan control in heating mode

The outdoor fan starts before 5s of the starting of compressor and then it will run in high speed for 40s;

The fan shall run at every speed for at least 80s;

When the compressor stops, the outdoor fan stops after 1min.

1.3.4 Defrosting function

When the defrosting condition is met, the compressor stops; the electronic expansion valve of all indoor units open in big angle; the outdoor fan stops after 40s of the stop of compressor, meanwhile, the 4-way valve reverses the direction; after the 4-way valve reverses the direction, the compressor starts; then begin to calculate the time of defrosting, the frequency of the compressor rises to reach the defrosting frequency.

1.3.5 Oil-returned control in heating mode

1.3.5.1 Oil-returned condition

The whole unit is operating in low frequency for a long time

1.3.5.2 Oil-returned process in heating mode

The indoor unit displays "H1"

1.3.5.3 Oil-returned finished condition in heating mode

The duration reaches 5min

1.4 Fan Mode

The compressor, the outdoor fan and the 4-way valve are closed; temperature setting range is 16~30°C.

2. Protection Function

2.1 Mode Conflict Protection of indoor unit

When the setting mode is different of different indoor unit, the unit runs in below status:

- a. The mode of the first operating indoor unit is the basic mode, then compare the mode of the other indoor units to see if there is a conflict. Cooling mode (dry mode) is in conflict with heating mode.
- b. Fan mode is in conflict with heating mode and the heating mode is the basic mode. No matter which indoor unit operates first, the unit will run in heating mode.

2.2 Overload protection function

When the tube temperature is a little low, the compressor raises the operation frequency; when the tube temperature is a little high, the compressor frequency is restricted or lows down the operation frequency; when the tube temperature is too high, the compressor protection stops running.

If the discharge temperature protection continuously appears for 6 times, the compressor can't resume running. The compressor can resume running after cutting off the power and then putting through the power. (if the running time of the compressor is longer than 7min, the protection times record will be cleared)

2.3 Discharge Protection Function

When the discharge temperature is a little low, the compressor raises the operation frequency; when the discharge temperature is a little high, the compressor frequency is restricted or lows down the operation frequency; when the discharge temperature is too high, the compressor protection stops running.

If the discharge temperature protection continuously appears for 6 times, the compressor can't resume running. The compressor can resume running after cutting off the power and then putting through the power. (if the running time of the compressor is longer than 7min, the protection times record will be cleared)

2.4 Communication malfunction

Detection of the quantity of installed indoor units:

After 3min of energizing, if the outdoor unit does not receive the communication data of certain indoor unit, the outdoor unit will judge that indoor unit is not installed and will treat it as it is not installed. If the outdoor unit receives the communication data of that indoor unit later, the outdoor unit will treat that unit as it is installed.

2.5 Overcurrent Protection

a. Overcurrent protection of complete unit; b. phase wire current protection; c. compressor phase current protection

2.6 Compressor high-pressure protection

2.6.1 When the high-pressure switch is detected cut off for 3s continuously, the compressor will enter high-pressure protection as it stops when reaching set temperature. Meanwhile, the outdoor unit will send the signal of "high-pressure protection" to the indoor units;

2.6.2 After the appearance of high-pressure protection, when the high-pressure switch is detected closed for 6s continuously, the compressor can resume running only after cutting off the power and then putting through the power.

2.7 Compressor overload protection

If the compressor overload switch is detected having movement, the indoor unit will display the corresponding malfunction as it stops when the indoor temperature reaching set temperature. When the compressor stops for more than 3min and the compressor overload switch is reset, the unit will resume operation status automatically. If the protection appears for more than 6 times (if the running time of the compressor is longer than 30min, the protection times record will be cleared), the unit can not resume operation status automatically, but can resume running only after cutting off the power and then putting through the power.

2.8 Compressor Phase-lacking Protection

When the compressor starts, if one of the three phases is detected open, the compressor will enter phase-lacking protection. The malfunction will be cleared after 1min, the unit will restart and then detect if there is still has phase-lacking protection. If the phase-lacking protection is detected for 6 times continuously, the compressor will not restart but can resume running only after cutting off the power and then putting through the power. If the running time of the compressor is longer than 7min, the protection times record will be cleared.

2.9 IPM Protection

2.9.1 When the IMP module protection is detected, the unit will stop as the indoor temperature reaching set temperature, PFC is closed, display IMP protection malfunction. After the compressor stops for 3min, the unit will resume operation status automatically; if the IMP protection is detected for more than 6 times continuously (If the running time of the compressor is longer than 7min, the protection times record will be cleared), the system will stop and send the signal of module protection to indoor unit. The unit can not resume operation status automatically, but can resume running only after cutting off the power and then putting through the power.

2.9.2 IMP module overheating protection

2.9.2.1 When $T_{IMP} > 85^{\circ}\text{C}$, prohibit to raise frequency;

2.9.2.2 When $T_{IMP} \geq 90^{\circ}\text{C}$, the operation frequency of compressor lows down by 15% every 90s according to the present capacity requirement of the complete unit. It will keep 90s after lowing down the frequency. After lowing down the frequency, if $T_{IMP} \geq 90^{\circ}\text{C}$, the unit will circulate the above movement until reaching the minimum frequency; if $85^{\circ}\text{C} < T_{IMP} < 90^{\circ}\text{C}$, the unit will run at this frequency; when $T_{IMP} \leq 85^{\circ}\text{C}$, the unit will run at the frequency according to the capacity requirement;

2.9.2.3 When $T_{IMP} \geq 95^{\circ}\text{C}$, the compressor stops. After the compressor stops for 3min, if $T_{IMP} < 85^{\circ}\text{C}$, the compressor and the outdoor fan will resume operation.

7. Installation Manual

7.1 Electrical Connections

(1)GWHD(14)NK3BO,GWHD(18)NK3DO,GWHD(24)NK3DO:

1. Remove the handle at the right side plate of the outdoor unit (one screw).
2. Remove the cable clamp, connect the power connection cable with the terminal at the row of connection and fix the connection. The fitting line distributing must be consistent with the indoor unit. terminal of line bank. Wiring should meet that of indoor unit.
3. Fix power connection wire by wire clamp.
4. Ensure wire has been fixed well.
5. Install the handle.

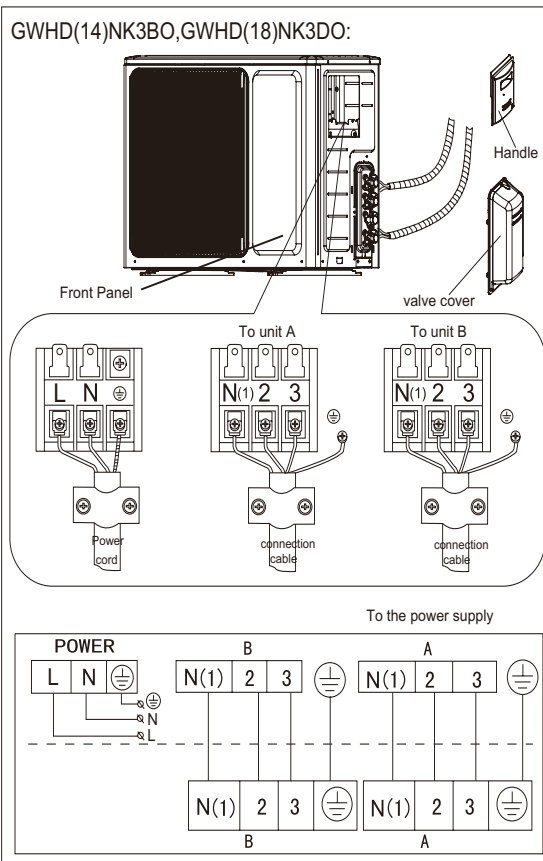

! An all-pole disconnection switch having a contact separation of at least 3mm in all pole should be connected in fixed wiring.

! Wrong wire connection may cause malfunction of some electric components. After fixing cable, ensure that leads between connection to fixed point have some space.

! The connection pipes and the connecting wirings of the unit A and unit B must be corresponding to each other respective.

! The appliance shall be installed in accordance with national wiring regulations.

Note: the above figures are only intended to be a simple diagram of the appliance and may not correspond to the appearance of the units that have been purchased.

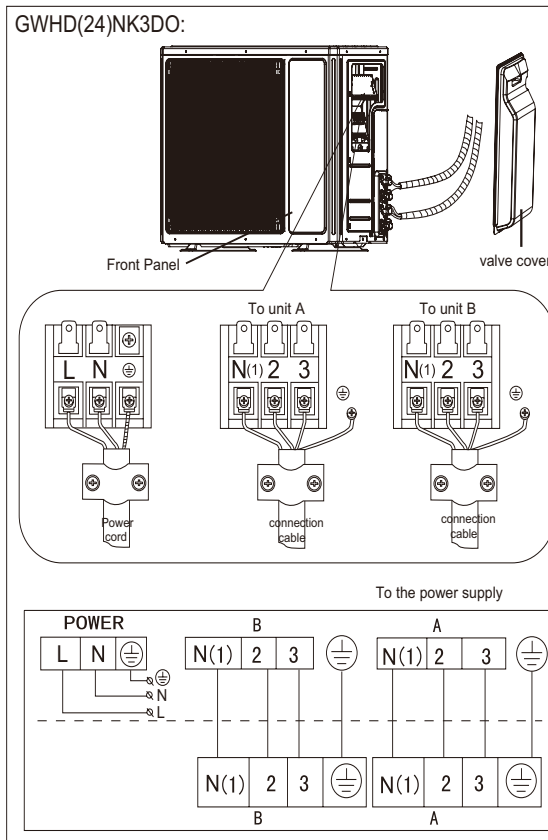



(2) GWHD(24)NK3EO:

1. Remove the valve cover at the right side plate of the outdoor unit (one screw).
2. Remove the cable clamp, connect the power connection cable with the terminal at the row of connection and fix the connection. The fitting line distributing must be consistent with the indoor unit. terminal of line bank. Wiring should meet that of indoor unit.
3. Fix power connection wire by wire clamp.
4. Ensure wire has been fixed well.
5. Install the valve cover.

 An all-pole disconnection switch having a contact separation of at least 3mm in all pole should be connected in fixed wiring.

 Wrong wire connection may cause malfunction of some electric components. After fixing cable, ensure that leads between connection to fixed point have some space.

 The connection pipes and the connecting wirings of the unit A, unit B and unit C must be corresponding to each other respective.

 The appliance shall be installed in accordance with national wiring regulations.



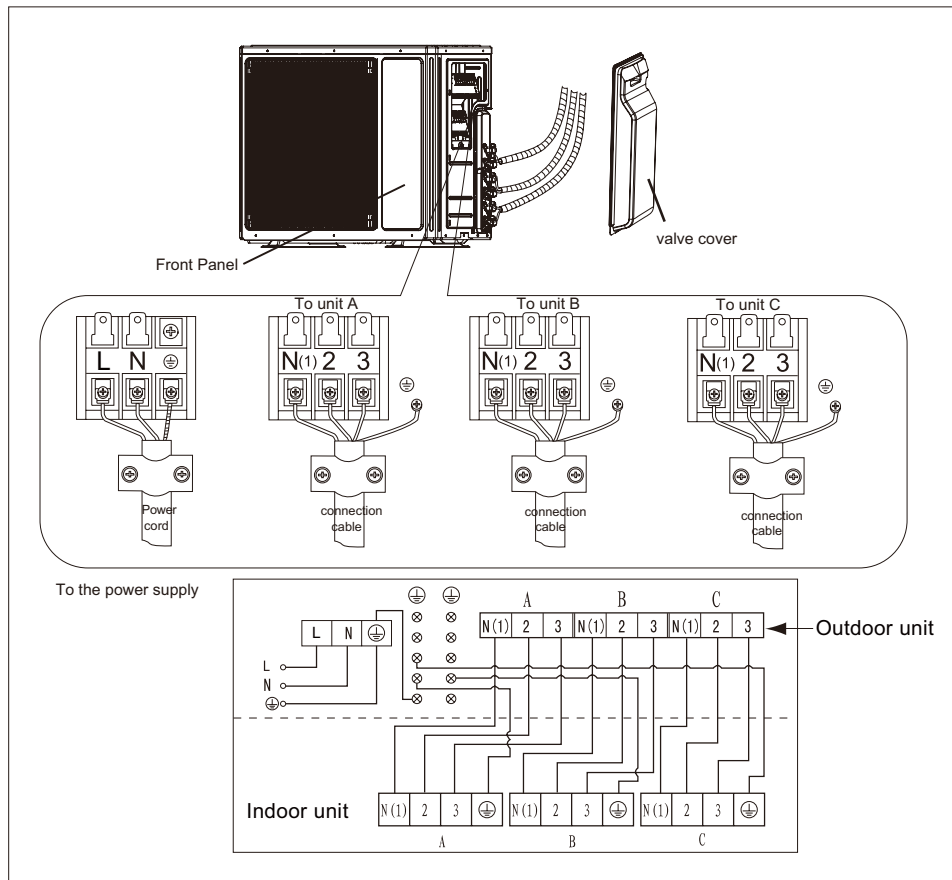

 Do not install the outdoor unit where it is exposed to the sunlight.

Note: the above figures are only intended to be a simple diagram of the appliance and may not correspond to the appearance of the units that have been purchased.





(3) GWHD(28)NK3BO:

1. Remove the valve cover at the right side plate of the outdoor unit (one screw).
2. Remove the cable clamp, connect the power connection cable with the terminal at the row of connection and fix the connection. The fitting line distributing must be consistent with the indoor unit. terminal of line bank. Wiring should meet that of indoor unit.
3. Fix power connection wire by wire clamp.
4. Ensure wire has been fixed well.
5. Install the valve cover.

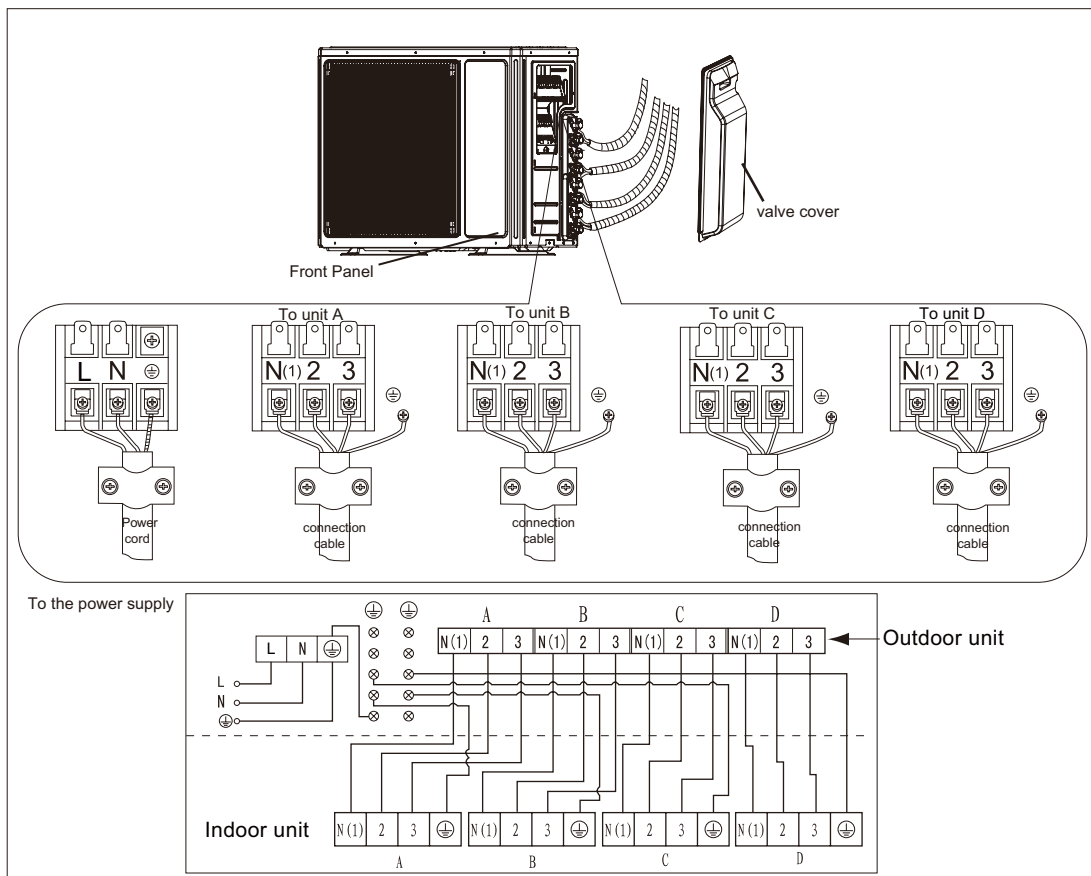
-  An all-pole disconnection switch having a contact separation of at least 3mm in all pole should be connected in fixed wiring.
-  Wrong wire connection may cause malfunction of some electric components. After fixing cable, ensure that leads between connection to fixed point have some space.
-  The connection pipes and the connecting wirings of the unit A, unit B, unit C and unit D must be corresponding to each other respective.
-  The appliance shall be installed in accordance with national wiring regulations.
-  Do not install the outdoor unit where it is exposed to the sunlight.



-  After having removed the packaging, check that the contents are intact and complete.
-  Handling must be done by suitably equipped qualified technical personnel using equipment that is suitable for the weight of the appliance.
-  The outdoor unit must always be kept upright.

7.2 Installing the Outdoor Unit

! Use bolts to secure the unit to a flat, solid floor. When mounting the unit on a wall or the roof, make sure the support is firmly secured so that it cannot move in the event of intense vibrations or a strong wind.

Do not install the outdoor unit in pits or air vents
Installing the pipes

! Use suitable connecting pipes and equipment for the refrigerant R410A.

Models(m)	14/18K	GWHD(24)NK3DO	24/28K
Max. connection pipe length	20	20	70
Max. connection pipe length(Simple one indoor unit)	10	10	20

! The refrigerant pipes must not exceed the maximum heights 10m.

! Wrap all the refrigerant pipes and joints.

! Tighten the connections using two wrenches working in opposite directions.

Caution: Installation Must be Performed in Accordance with the NEC/CEC by Authorized Personnel Only.

Humid air left inside the refrigerant circuit can cause compressor malfunction. After having connected the indoor and outdoor units, bleed the air and humidity from the refrigerant circuit using a vacuum pump.

1. Unscrew and remove the caps from the 2-way and 3-way valves.
2. Unscrew and remove the cap from the service valve.
3. Connect the vacuum pump hose to the service valve.
4. Operate the vacuum pump for 10-15 minutes until an absolute vacuum of 10 mm Hg has been reached.
5. With the vacuum pump still in operation, close the low-pressure knob on the vacuum pump coupling. Stop the vacuum pump.
6. Open the 2-way valve by 1/4 turn and then close it after 10 seconds. Check all the joints for leaks using liquid soap or an electronic leak device.
7. Turn the body of the 2-way and 3-way valves. Disconnect the vacuum pump hose.
8. Replace and tighten all the caps on the valves.

Diameter (mm)	Twisting moment (N.m)
Φ6	15-20
Φ9.52	35-40
Φ16	60-65
Φ12	45-50
Φ19	70-75

18K unit need to be installed the indoor unit

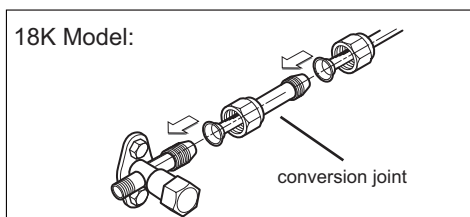

Install the drain fitting and the drain hose (for model with heat pump only)

Condensation is produced and flows from the outdoor unit when the appliance is operating in the heating mode. In order not to disturb neighbours and to respect the environment, install a drain fitting and a drain hose to channel the condensate water. Install the drain fitting and rubber washer on the outdoor unit chassis and connect a drain hose to it as shown in the figure.

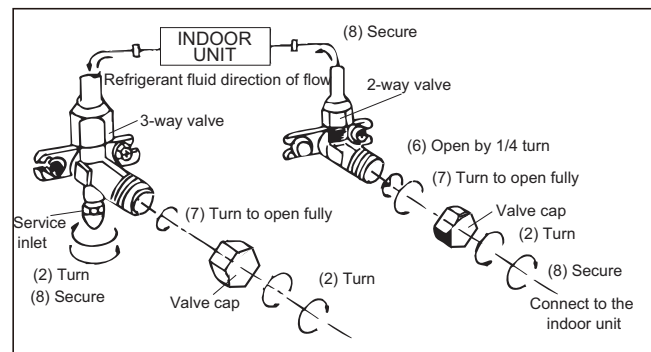
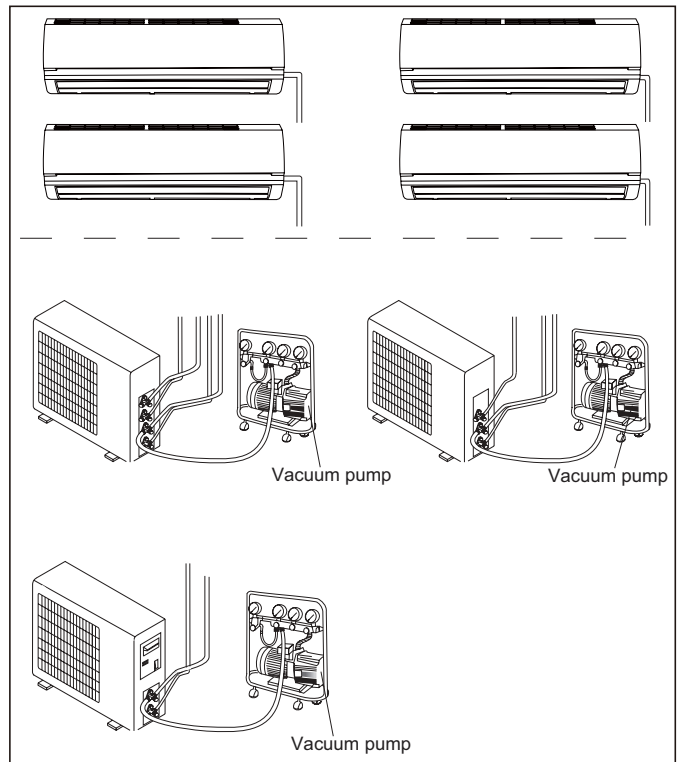
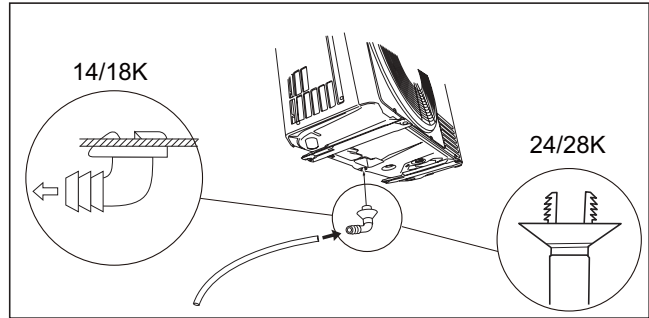

7.3 Installation Dimension Diagram

- ⚠ Use suitable instruments for the refrigerant R410A.
- ⚠ Do not use any other refrigerant than R410A.
- ⚠ Do not use mineral oils to clean the unit.
- ⚠ The installation must be done by trained and qualified service personnel with reliability according to this manual.
- ⚠ Contact service center before installation to avoid the malfunction due to unprofessional installation.
- ⚠ When picking up and moving the units, you must be guided by trained and qualified person.
- ⚠ Ensure that the recommended space is left around the appliance.

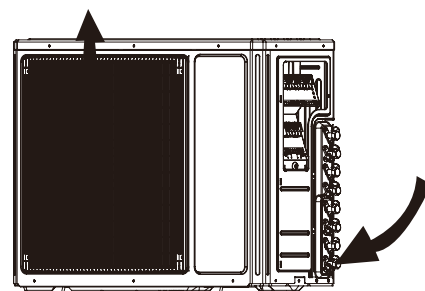

GWHD(14)NK3BO, GWHD(18)NK3DO

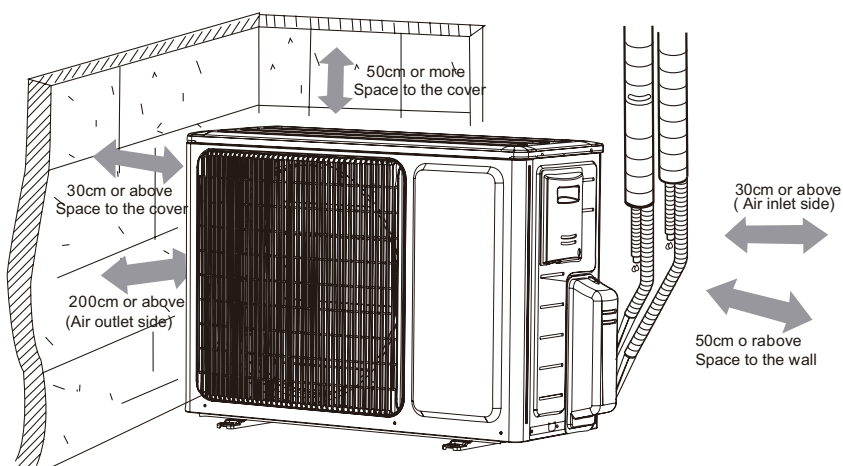

GWHD(24)NK3DO, GWHD(24)NK3EO, GWHD(28)NK3BO

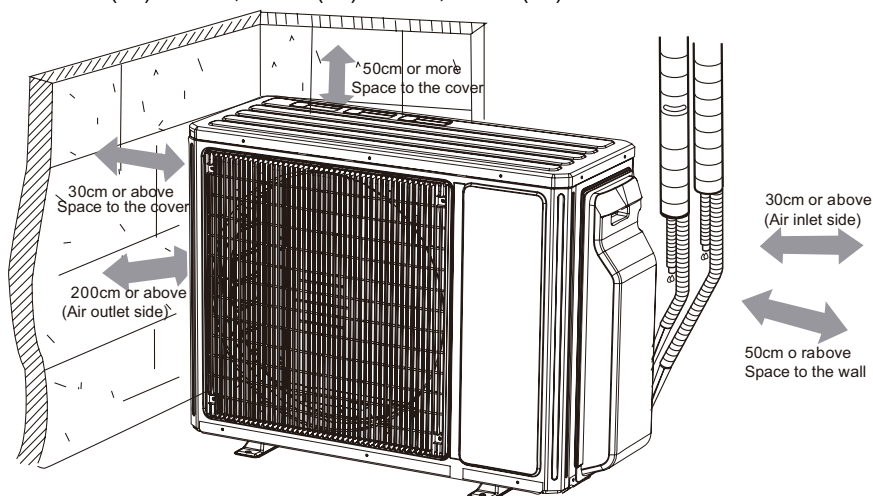

This is just the schematic plan, please refer to the actual product.

7.4 Check after Installation

Check Items	Problems Owing to Improper Installation
Is the installation reliable?	The unit may drop, vibrate or make noises
Has the gas leakage been checked?	May cause unsatisfactory cooling (heating) effect
Is the thermal insulation of the unit sufficient?	May cause condensation and water dropping
Is the drainage smooth?	May cause condensation and water dropping
Does the power supply voltage accord with the rated voltage specified on the nameplate?	The unit may bread down or the components may be burned out
Are the lines and pipelines correctly installed?	The unit may bread down or the components may be burned out
Has the unit been safely grounded?	Risk of electrical leakage
Are the models of lines in conformity with requirements?	The unit may bread down or the components may be burned out
Are there any obstacles near the air inlet and outlet of the indoor and outdoor units?	The unit may bread down or the components may be burned out
Have the length of refrigerating pipe and refrigerant charge amount been recorded?	It is not easy to decide the charge amount of refrigerant.

8. Exploded Views and Parts List

(1) Models: GWHD(14)NK3BO,GWHD(18)NK3DO

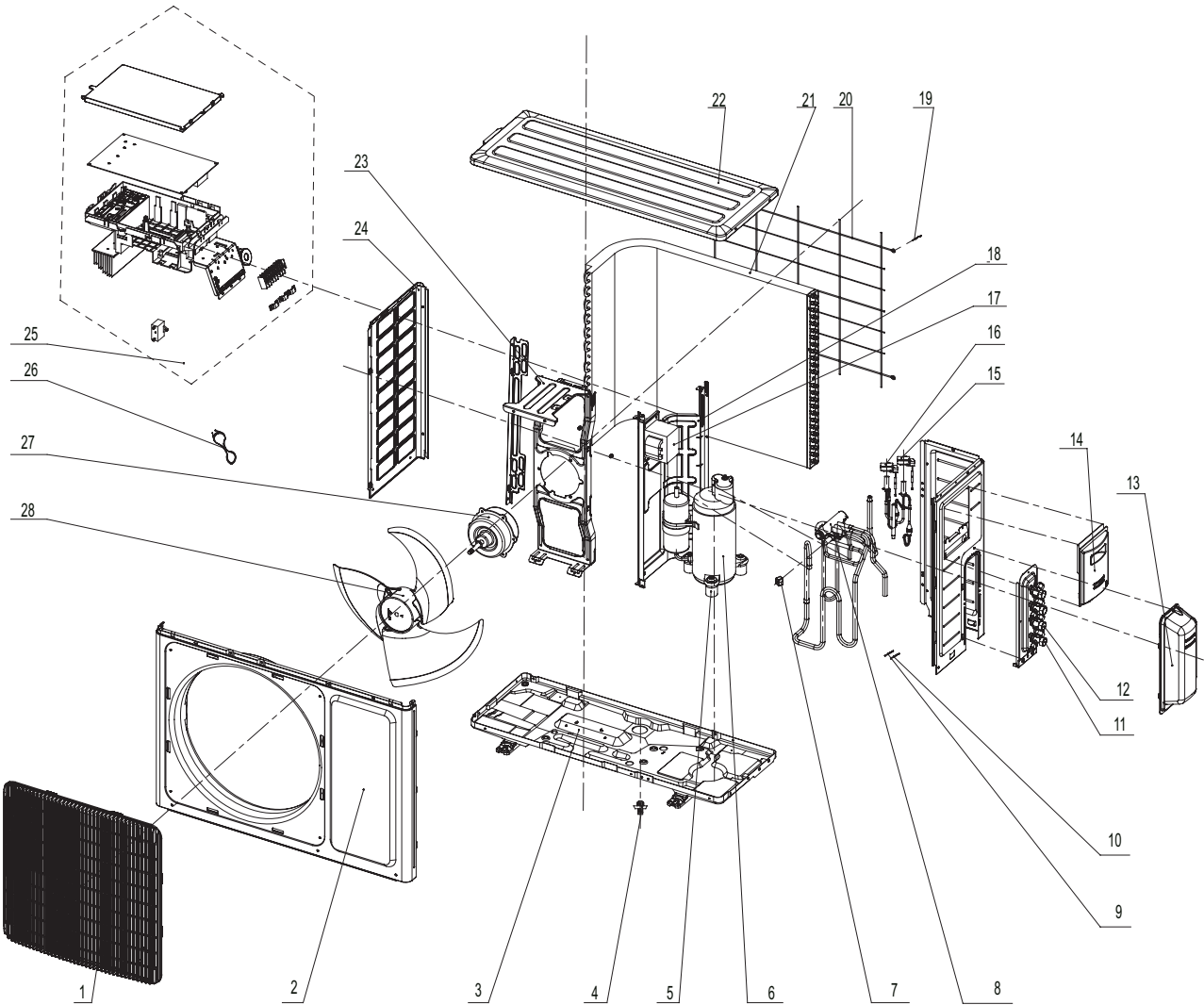

NO.	Description	Part Code		Qty
		GWHD(14)NK3BO	GWHD(18)NK3DO	
		Product Code	Product Code	
		CB228W0120	CB228W0080	
1	Front Grill	22413015	22413015	1
2	Cabinet	01433034P	01433034P	1
3	Chassis Sub-assy	01205161P	01205161P	1
4	Drainage Joint	26113009	26113009	1
5	Compressor Gasket	76710236	76710236	3
6	Compressor and fittings	00103501	00103501	1
7	Magnet Coil	4300040033	4300040033	1
8	4-way Valve Assy	03123438	03123438	1
9	Temperature Sensor	3900007301	3900007301	1
10	Temperature Sensor	39000073	39000073	1
11	Cut-off Valve	071302391	071302391	2
12	Cut-off Valve	07130239	07130239	2
13	Valve cover	22242101	22242101	1
14	Big Handle	26233048	26233048	1
15	Electric expand valve fitting	4300008401	4300008401	1
16	Electric expand valve fitting	43000084	43000084	1
17	PFC induction	43120130	43120130	1
18	Clapboard Sub-Assy	01233117	01233117	1
19	Temperature Sensor	3900030901	3900030901	1
20	Rear Grill	01475019	01475019	1
21	Condenser Assy	01113763	01113763	1
22	Top Cover	01253034P	01253034P	1
23	Motor Support Sub-Assy	01703398	01703398	1
24	Left Side Plate	01303169P	01303169P	1
25	Electric Box Assy	02603411	02603411	1
26	Connecting Cable	40020318	40020318	1
27	Fan Motor	15013162	15013162	1
28	Axial Flow Fan	10333010	10333010	1

The data above are subject to change without notice.

(2) Model: GWHD(24)NK3DO(CB228W0070)

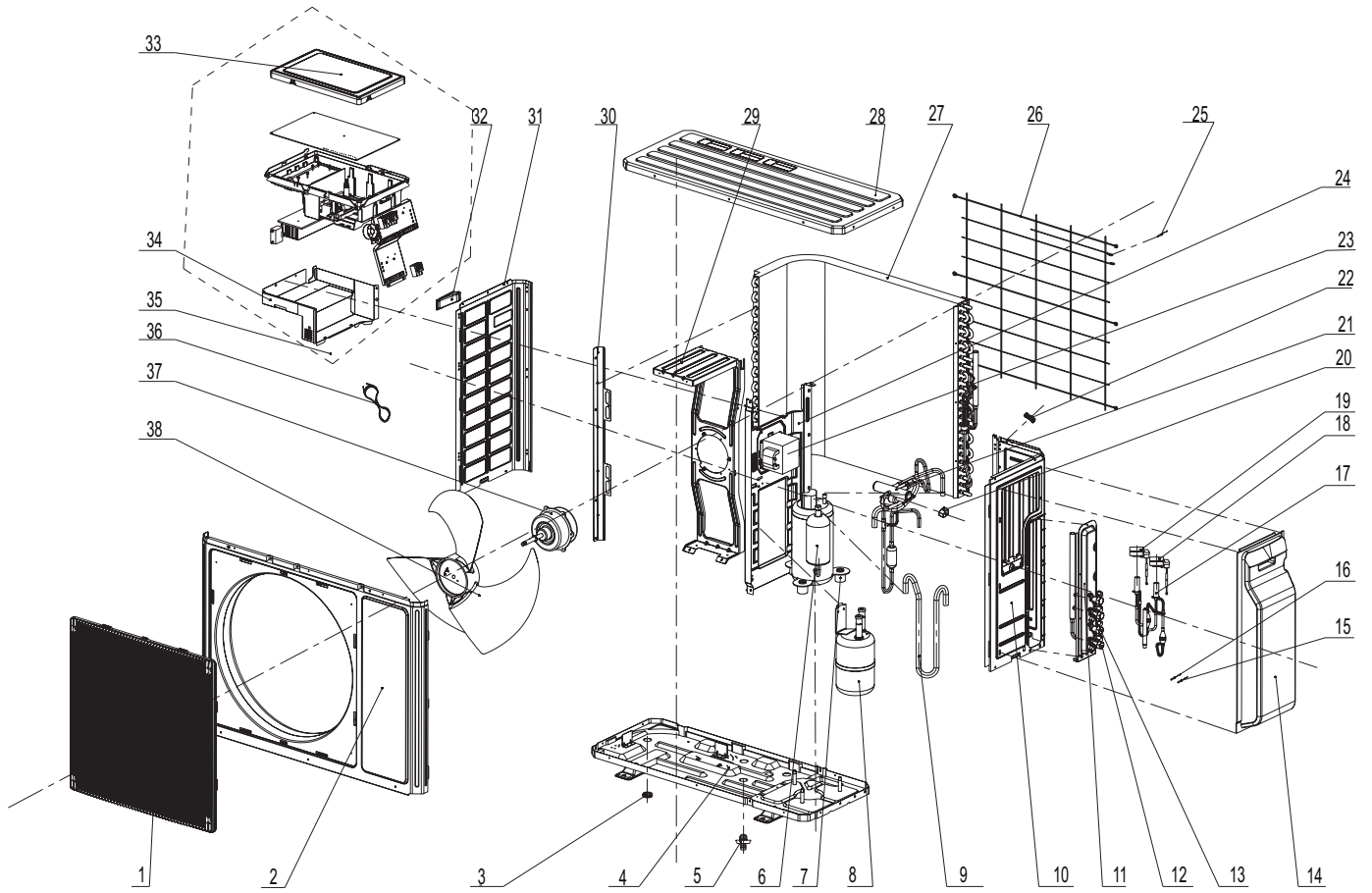

NO.	Description	Part Code		Qty
		GWHD(24)NK3DO		
		CB228W0070		
1	Front grill	22415002	1	
2	Front Panel	01535008P	1	
3	Drainage Plug	06813401	3	
4	Chassis Sub-assy	01203942P	1	
5	Drainage Connector	06123401	1	
6	Compressor and fittings	00105036	1	
7	Compressor Gasket	76710207	3	
8	Gas-liquid Separator Assy	07225017	1	
9	Inhalation Tube	03723455	1	
10	Right Side Plate	01303194P	1	
11	Valve Support Sub-Assy	0171312802P	1	
12	Cut-off Valve	07130239	2	
13	Cut-off Valve	071302391	2	
14	Valve cover	20123029	1	
15	Temperature Sensor	3900007301	1	
16	Temperature Sensor	39000073	1	
17	Electronic Expansion Valve assy	07133457	1	
18	Electric expand valve fitting	4300008401	1	
19	Electric expand valve fitting	43000084	1	
20	Magnet Coil	4300040033	1	
21	4-way Valve Assy	03123415	1	
22	Wiring clamp	26115004	1	
23	PFC induction	43120129	1	
24	Clapboard assy	01233116	1	
25	Temperature Sensor	3900030901	1	
26	Rear Grill	01473043	1	
27	Condenser Assy	01113710	1	
28	Top Cover	01255005P	1	
29	Motor Support Sub-Assy	0170512001	1	
30	Condenser support plate	01173415	1	
31	Left Side Plate	01305041P	1	
32	left handle	26235401	1	
33	Insulated board (cover of electric box)	20113003	1	
34	Electric box (fireproofing)	01413148	1	
35	Electric Box Assy	0260337202	1	
36	Connecting Cable	400205405	1	
37	Fan Motor	1501506303	1	
38	Axial Flow Fan	10335008	1	

The data above are subject to change without notice.

(3) Model: GWHD(24)NK3DO(CB228W0071)

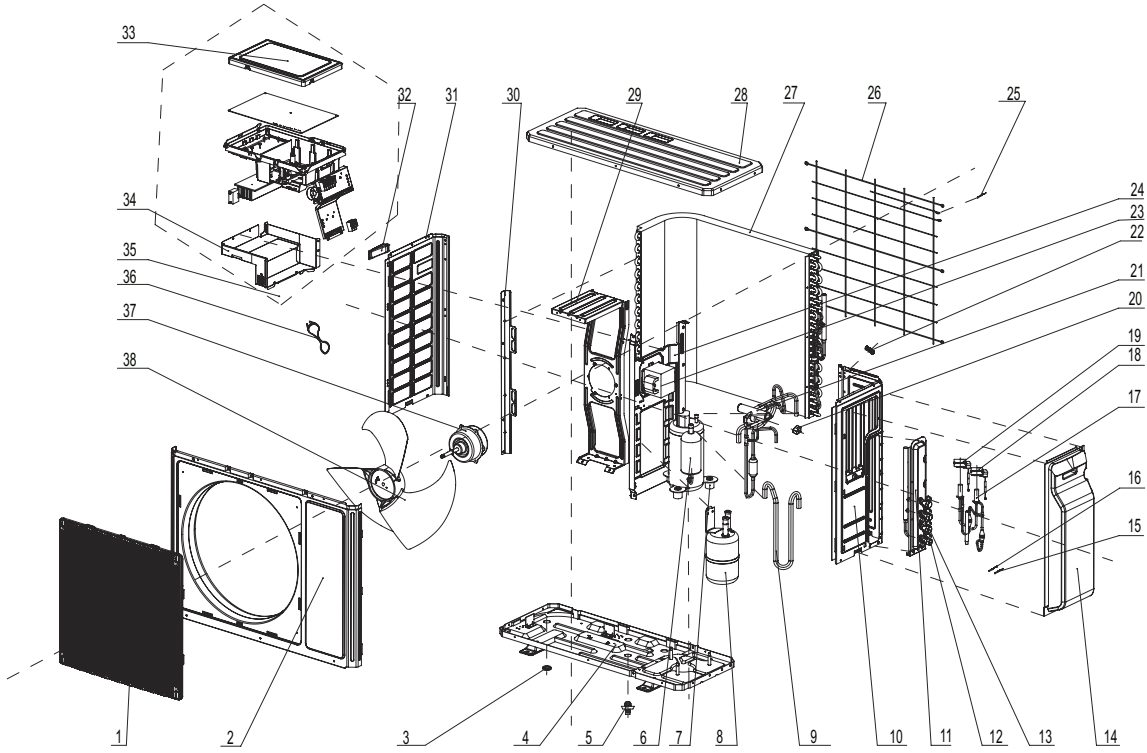

NO.	Description	Part Code	Qty
		GWHD(24)NK3DO	
		Product code	
		CB228W0071	
1	Front grill	22415002	1
2	Front Panel	01535008P	1
3	Drainage Plug	06813401	3
4	Chassis Sub-assy	01203942P	1
5	Drainage Connector	06123401	1
6	Compressor and fittings	00105036	1
7	Compressor Gasket	76710207	3
8	Gas-liquid Separator Assy	07225017	1
9	Inhalation Tube	03723455	1
10	Right Side Plate	01303194P	1
11	Valve Support Sub-Assy	0171312802P	1
12	Cut-off Valve	07130239	2
13	Cut-off Valve	071302391	2
14	Valve cover	20123029	1
15	Temperature Sensor	3900007301	1
16	Temperature Sensor	39000073	1
17	Electronic Expansion Valve assy	07133457	1
18	Electric expand valve fitting	4300008401	1
19	Electric expand valve fitting	43000084	1
20	Magnet Coil	4300040033	1
21	4-way Valve Assy	03123415	1
22	Wiring clamp	26115004	1
23	PFC induction	43120129	1
24	Clapboard assy	01233116	1
25	Temperature Sensor	3900030901	1
26	Rear Grill	01473043	1
27	Condenser Assy	01113710	1
28	Top Cover	01255005P	1
29	Motor Support Sub-Assy	0170512001	1
30	Condenser support plate	01173415	1
31	Left Side Plate	01305041P	1
32	left handle	26235401	1
33	Insulated board (cover of electric box)	20113003	1
34	Electric box (fireproofing)	01413148	1
35	Electric Box Assy	02603785	1
36	Connecting Cable	400205405	0
37	Fan Motor	1501506303	1
38	Axial Flow Fan	10335008	1

The data above are subject to change without notice.

(4) Model: GWHD(24)NK3EO(CB228W0100)

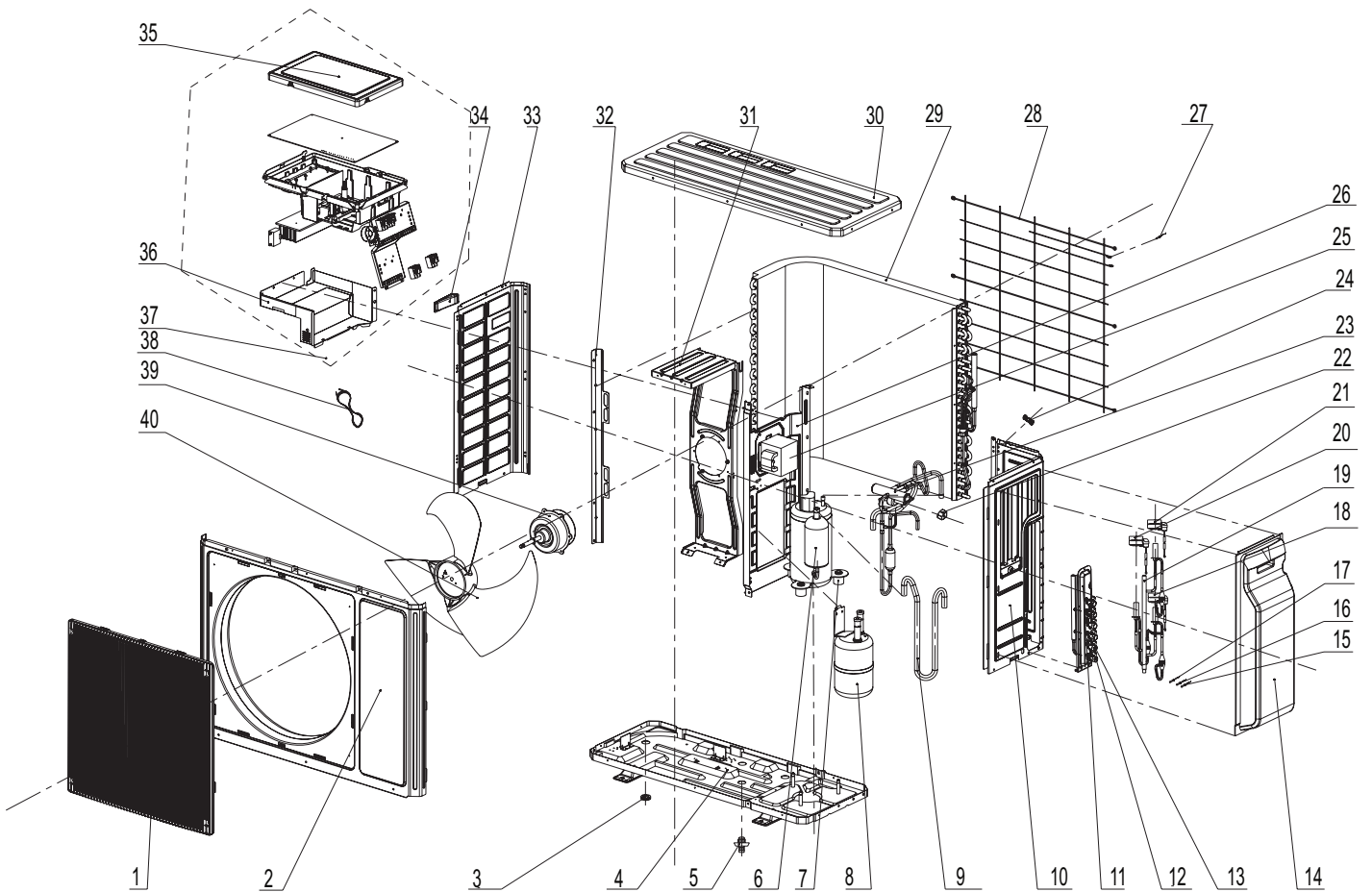

NO.	Description	Part Code		Qty
		GWHD(24)NK3EO		
		CB228W0100		
1	Front grill	22415002	1	
2	Front Panel	01535008P	1	
3	Drainage Plug	06813401	3	
4	Chassis Sub-assy	01203942P	1	
5	Drainage Connector	06123401	1	
6	Compressor and fittings	00105036	1	
7	Compressor Gasket	76710207	3	
8	Gas-liquid Separator Assy	07225017	1	
9	Inhalation Tube	03723455	1	
10	Right Side Plate	01303194P	1	
11	Valve support assy	0710306601	1	
12	Cut-off Valve	071302391	3	
13	Cut-off Valve	07130239	3	
14	Valve cover	20123029	1	
15	Temperature Sensor	3900007302	1	
16	Temperature Sensor	3900007301	1	
17	Temperature Sensor	39000073	1	
18	Electric expand valve fitting	4300008402	1	
19	Electronic Expansion Valve assy	07133456	1	
20	Electric expand valve fitting	43000084	1	
21	Electric expand valve fitting	43000084	1	
22	Magnet Coil	4300040033	1	
23	4-way Valve Assy	03123415	1	
24	Wiring clamp	26115004	1	
25	PFC induction	43120129	1	
26	Clapboard assy	01233116	1	
27	Temperature Sensor	3900030901	1	
28	Rear Grill	01473043	1	
29	Condenser Assy	01113710	1	
30	Top Cover	01255005P	1	
31	Motor Support Sub-Assy	0170512001	1	
32	Condenser support plate	01173415	1	
33	Left Side Plate	01305041P	1	
34	left handle	26235401	1	
35	Insulated board (cover of electric box)	20113003	1	
36	Electric box (fireproofing)	01413148	1	
37	Electric Box Assy	0260337201	1	
38	Connecting Cable	400205405	0	
39	Fan Motor	1501506303	1	
40	Axial Flow Fan	10335008	1	

The data above are subject to change without notice.

(5) Model: GWHD(24)NK3EO(CB228W0101)

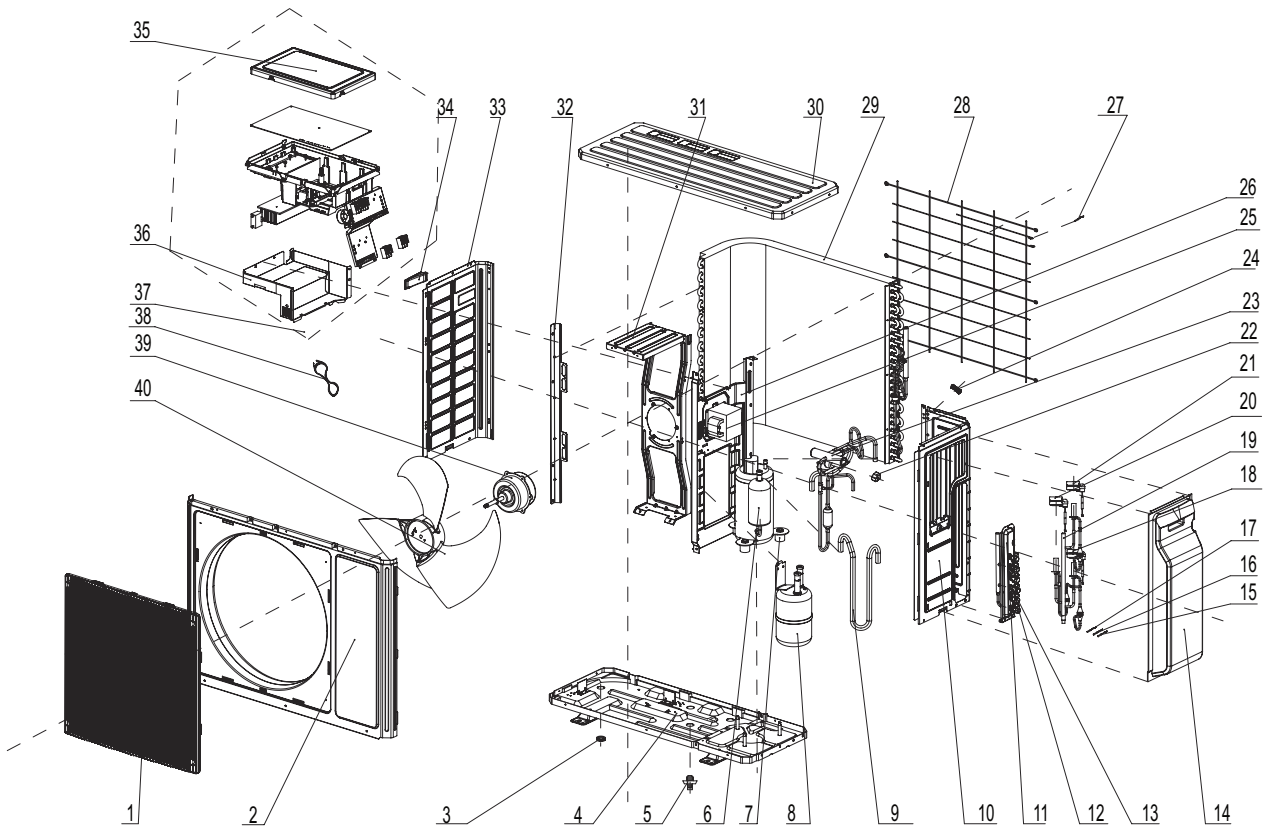

NO.	Description	Part Code	Qty
		GWHD(24)NK3EO	
		Product code	
		CB228W0101	
1	Front grill	22415002	1
2	Front Panel	01535008P	1
3	Drainage Plug	06813401	3
4	Chassis Sub-assy	01203942P	1
5	Drainage Connector	06123401	1
6	Compressor and fittings	00105036	1
7	Compressor Gasket	76710207	3
8	Gas-liquid Separator Assy	07225017	1
9	Inhalation Tube	03723455	1
10	Right Side Plate	01303194P	1
11	Valve support assy	0710306601	1
12	Cut-off Valve	071302391	3
13	Cut-off Valve	07130239	3
14	Valve cover	20123029	1
15	Temperature Sensor	3900007302	1
16	Temperature Sensor	3900007301	1
17	Temperature Sensor	39000073	1
18	Electric expand valve fitting	4300008402	1
19	Electronic Expansion Valve assy	07133456	1
20	Electric expand valve fitting	43000084	1
21	Electric expand valve fitting	43000084	1
22	Magnet Coil	4300040033	1
23	4-way Valve Assy	03123415	1
24	Wiring clamp	26115004	1
25	PFC induction	43120129	1
26	Clapboard assy	01233116	1
27	Temperature Sensor	3900030901	1
28	Rear Grill	01473043	1
29	Condenser Assy	01113710	1
30	Top Cover	01255005P	1
31	Motor Support Sub-Assy	0170512001	1
32	Condenser support plate	01173415	1
33	Left Side Plate	01305041P	1
34	left handle	26235401	1
35	Insulated board (cover of electric box)	20113003	1
36	Electric box (fireproofing)	01413148	1
37	Electric Box Assy	02603786	1
38	Connecting Cable	400205405	0
39	Fan Motor	1501506303	1
40	Axial Flow Fan	10335008	1

The data above are subject to change without notice.

(6) Model: GWHD(28)NK3BO(CB228W0110)

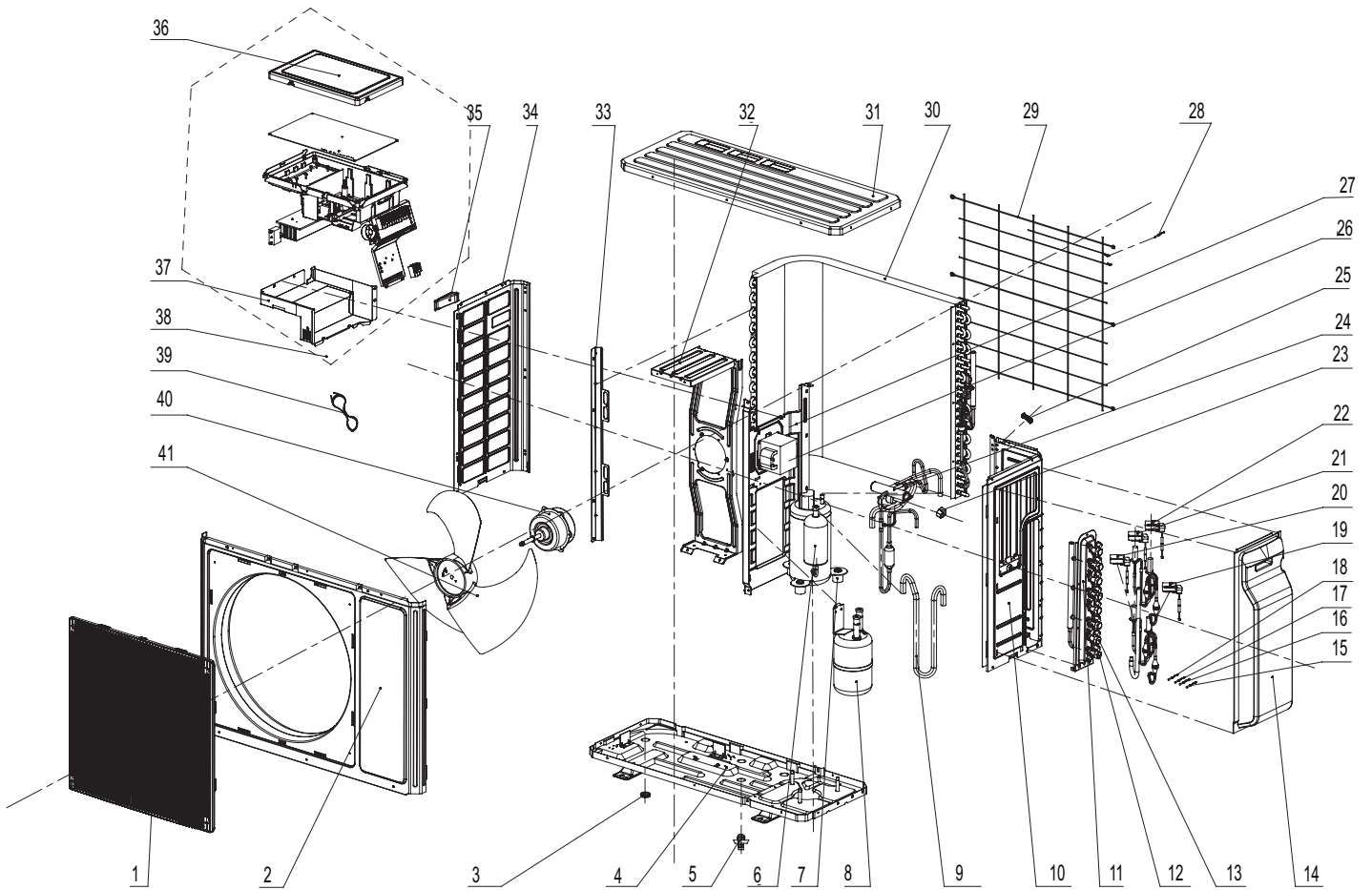

NO.	Description	Part Code		Qty
		GWHD(28)NK3BO		
		Product Code		
		CB228W0110		
1	Front grill	22415002		1
2	Front Panel	01535008P		1
3	Drainage Plug	06813401		3
4	Chassis Sub-assy	01203942P		1
5	Drainage Connector	06123401		1
6	Compressor and fittings	00105036		1
7	Compressor Gasket	76710207		1
8	Gas-liquid Separator Assy	07225017		1
9	Inhalation Tube	03723455		1
10	Right Side Plate	01303194P		1
11	Valve support assy	07103066		1
12	Cut-off Valve	071302391		4
13	Cut-off Valve	07130239		4
14	Valve cover	20123029		1
15	Temperature Sensor	3900007303		1
16	Temperature Sensor	3900007302		1
17	Temperature Sensor	3900007301		1
18	Temperature Sensor	39000073		1
19	Electric expand valve fitting	4300008403		1
20	Electric expand valve fitting	4300008402		1
21	Electric expand valve fitting	4300008401		1
22	Electric expand valve fitting	43000084		1
23	Magnet Coil	4300040033		1
24	4-way Valve Assy	03123415		1
25	Wiring clamp	26115004		1
26	PFC induction	43120129		1
27	Clapboard assy	01233116		1
28	Temperature Sensor	3900030901		1
29	Rear Grill	01473043		1
30	Condenser Assy	01113710		1
31	Top Cover	01255005P		1
32	Motor Support Sub-Assy	0170512001		1
33	Condenser support plate	01173415		1
34	Left Side Plate	01305041P		1
35	left handle	26235401		1
36	Insulated board (cover of electric box)	20113003		1
37	Electric box (fireproofing)	01413148		1
38	Electric Box Assy	02603372		1
39	Connecting Cable	400205405		1
40	Fan Motor	1501506303		1
41	Axial Flow Fan	10335008		1

The data above are subject to change without notice.

(7) Model: GWHD(28)NK3BO(CB228W0111)

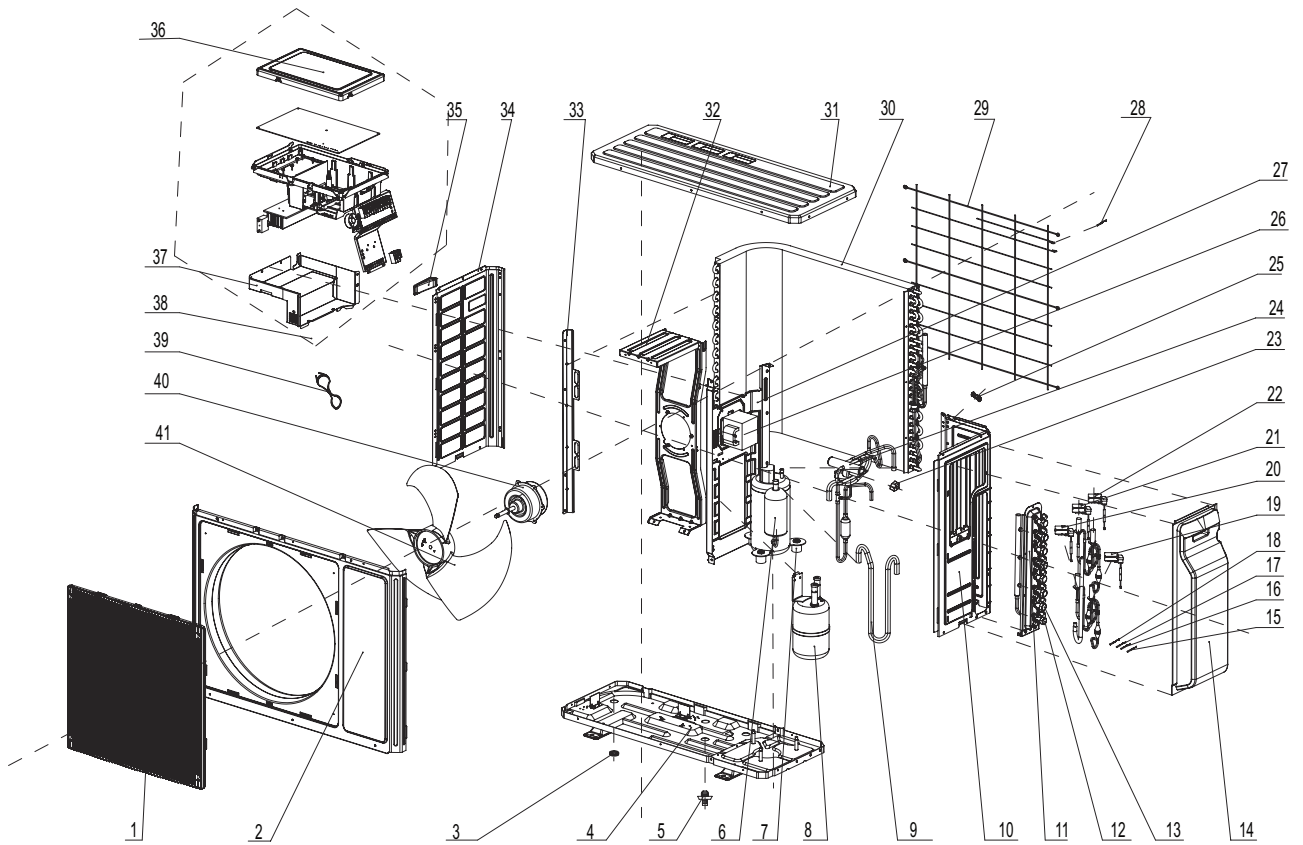

NO.	Description	Part Code	Qty
		GWHD(28)NK3BO	
		Product code	
		CB228W0111	
1	Front grill	22415002	1
2	Front Panel	01535008P	1
3	Drainage Plug	06813401	3
4	Chassis Sub-assy	01203942P	1
5	Drainage Connector	06123401	1
6	Compressor and fittings	00105036	1
7	Compressor Gasket	76710207	1
8	Gas-liquid Separator Assy	07225017	1
9	Inhalation Tube	03723455	1
10	Right Side Plate	01303194P	1
11	Valve support assy	07103066	1
12	Cut-off Valve	071302391	4
13	Cut-off Valve	07130239	4
14	Valve cover	20123029	1
15	Temperature Sensor	3900007303	1
16	Temperature Sensor	3900007302	1
17	Temperature Sensor	3900007301	1
18	Temperature Sensor	39000073	1
19	Electric expand valve fitting	4300008403	1
20	Electric expand valve fitting	4300008402	1
21	Electric expand valve fitting	4300008401	1
22	Electric expand valve fitting	43000084	1
23	Magnet Coil	4300040033	1
24	4-way Valve Assy	03123415	1
25	Wiring clamp	26115004	1
26	PFC induction	43120129	1
27	Clapboard assy	01233116	1
28	Temperature Sensor	3900030901	1
29	Rear Grill	01473043	1
30	Condenser Assy	01113710	1
31	Top Cover	01255005P	1
32	Motor Support Sub-Assy	0170512001	1
33	Condenser support plate	01173415	1
34	Left Side Plate	01305041P	1
35	left handle	26235401	1
36	Insulated board (cover of electric box)	20113003	1
37	Electric box (fireproofing)	01413148	1
38	Electric Box Assy	02603750	1
39	Connecting Cable	400205405	0
40	Fan Motor	1501506303	1
41	Axial Flow Fan	10335008	1

The data above are subject to change without notice.

9. Troubleshooting

9.1 Malfunction Indicator

Note: ○: off ●: on ◎: blink

When several malfunctions occur at the same time, they will be displayed in circulation and every malfunction is displayed for 5s.

NO	Malfunction description	LED1	LED2	LED3	LED4
0	Normal stop	○	○	○	○
1	Compressor run	●	○	○	○
2	Compressor overload protection	◎	○	○	○
3	Discharge protection	○	●	○	○
4	Outdoor unit overload protection	●	●	○	○
5	High pressure protection	◎	●	○	○
6	Over current protection	○	◎	○	○
7	IMP protection	●	◎	○	○
8	IMP over heating protection	◎	◎	○	○
9	PFC protection (including PFC overheating protection)	○	○	●	○
10	Phase current protection	●	○	●	○
11	Over voltage protection	◎	○	●	○
12	Insufficient voltage protection	○	●	●	○
13	Start failure	●	●	●	○
14	Compressor desynchronizing	◎	●	●	○
15	Compressor phase-lacking protection	○	◎	●	○
16	Compressor phase current detection malfunction	●	◎	●	○
17	Memory chip mistake	◎	◎	●	○
18	DC power supply circuit-short	○	○	◎	○
19	Defrosting	●	○	◎	○
20	Oil return	◎	○	◎	○
21	Complete unit frequency restriction protection	○	●	◎	○
22	Complete unit frequency dropping protection	●	●	◎	○
23	Unit A frequency restriction or frequency dropping protection	◎	●	◎	○
24	Unit B frequency restriction or frequency dropping protection	○	◎	◎	○
25	Unit C frequency restriction or frequency dropping protection	●	◎	◎	○
26	Unit D frequency restriction or frequency dropping protection	◎	◎	◎	○
27	Outdoor ambient temperature sensor protection	○	○	○	●
28	Outdoor tube temperature sensor protection	●	○	○	●
29	Discharge temperature sensor protection	◎	○	○	●
30	IPM thermal resistance malfunction	○	●	○	●
31	Unit A liquid pipe temperature sensor malfunction	●	●	○	●
32	Unit A gas pipe temperature sensor malfunction	◎	●	○	●
33	Unit B liquid pipe temperature sensor malfunction	○	◎	○	●
34	Unit B gas pipe temperature sensor malfunction	●	◎	○	●
35	Unit C liquid pipe temperature sensor malfunction	◎	◎	○	●
36	Unit C gas pipe temperature sensor malfunction	○	○	●	●
37	Unit D liquid pipe temperature sensor malfunction	●	○	●	●
38	Unit D gas pipe temperature sensor malfunction	◎	○	●	●
39	Unit A mode conflict	○	●	●	●
40	Unit B mode conflict	●	●	●	●
41	Unit C mode conflict	◎	●	●	●
42	Unit D mode conflict	○	◎	●	●

43	Communication failure with Unit A	●	◎	●	●
44	Communication failure with Unit B	◎	◎	●	●
45	Communication failure with Unit C	○	○	◎	●
46	Communication failure with Unit D	●	○	◎	●
47	Unit A freeze protection	◎	○	◎	●
48	Unit B freeze protection	○	●	◎	●
49	Unit C freeze protection	●	●	◎	●
50	Unit D freeze protection	◎	●	◎	●
51	Unit A overheating prevention protection	○	◎	◎	●
52	Unit B overheating prevention protection	●	◎	◎	●
53	Unit C overheating prevention protection	◎	◎	◎	●
54	Unit D overheating prevention protection	○	○	○	◎
55	Unit A communication wire misconnection or expansion valve malfunction	●	○	○	◎
56	Unit B communication wire misconnection or expansion valve malfunction	◎	○	○	◎
57	Unit C communication wire misconnection or expansion valve malfunction	○	●	○	◎
58	Unit D communication wire misconnection or expansion valve malfunction	●	●	○	◎

9.2 Malfunction Checking and Elimination

Note: discharge the position in below pictures with discharge resistance after open the top cover and check if the voltage is below 20V with universal meter, then begin to check.

14/18K:

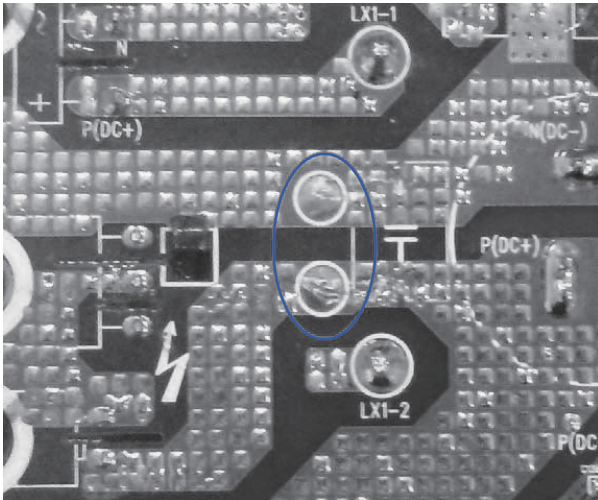

24/28K:

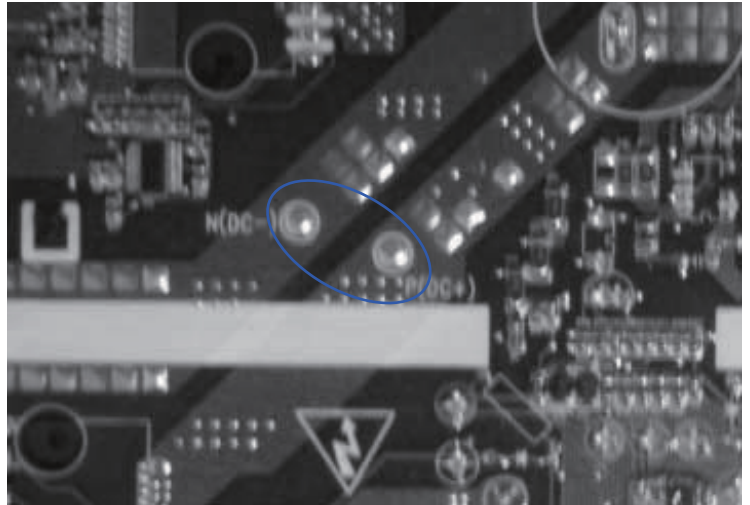

(1) IPM protection malfunction:

Main checking point:

- If the input voltage of the unit is within normal range?
- If the connection wire of compressor is connected well? Is it loose? If the connection sequence is correct?
- If the resistance of compressor coil is normal? If the isolation of compressor coil with copper pipe is good?
- If the unit is overloaded? If the heat radiation of the unit is good?
- If the refrigerant charge is suitable?

Flow chart:

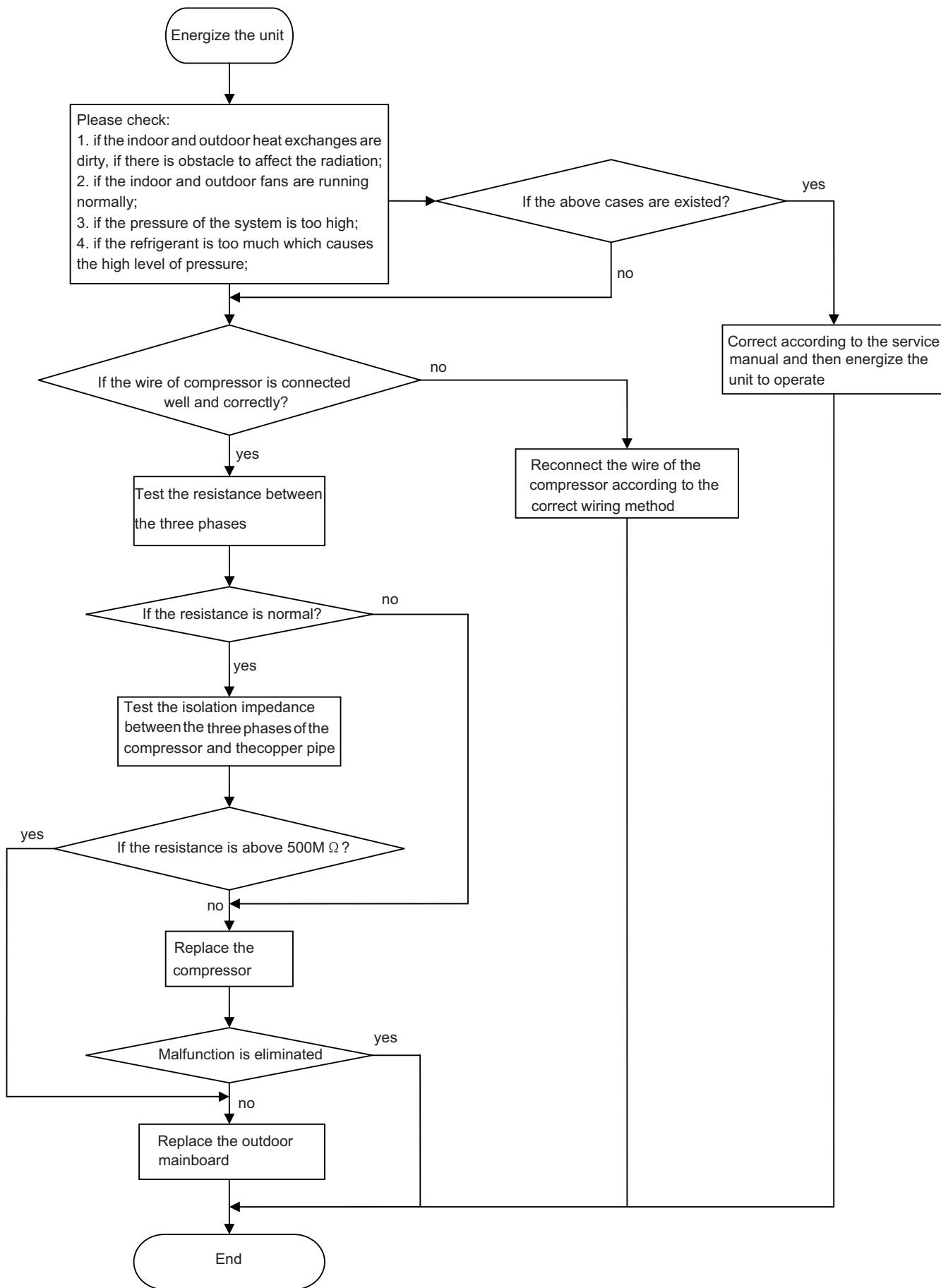

(2) PFC protection malfunction

Main checking points:

- If the power supply is normal;
- Check if the connection wire of induction is connected well and if the induction is broken;

Flow chart:

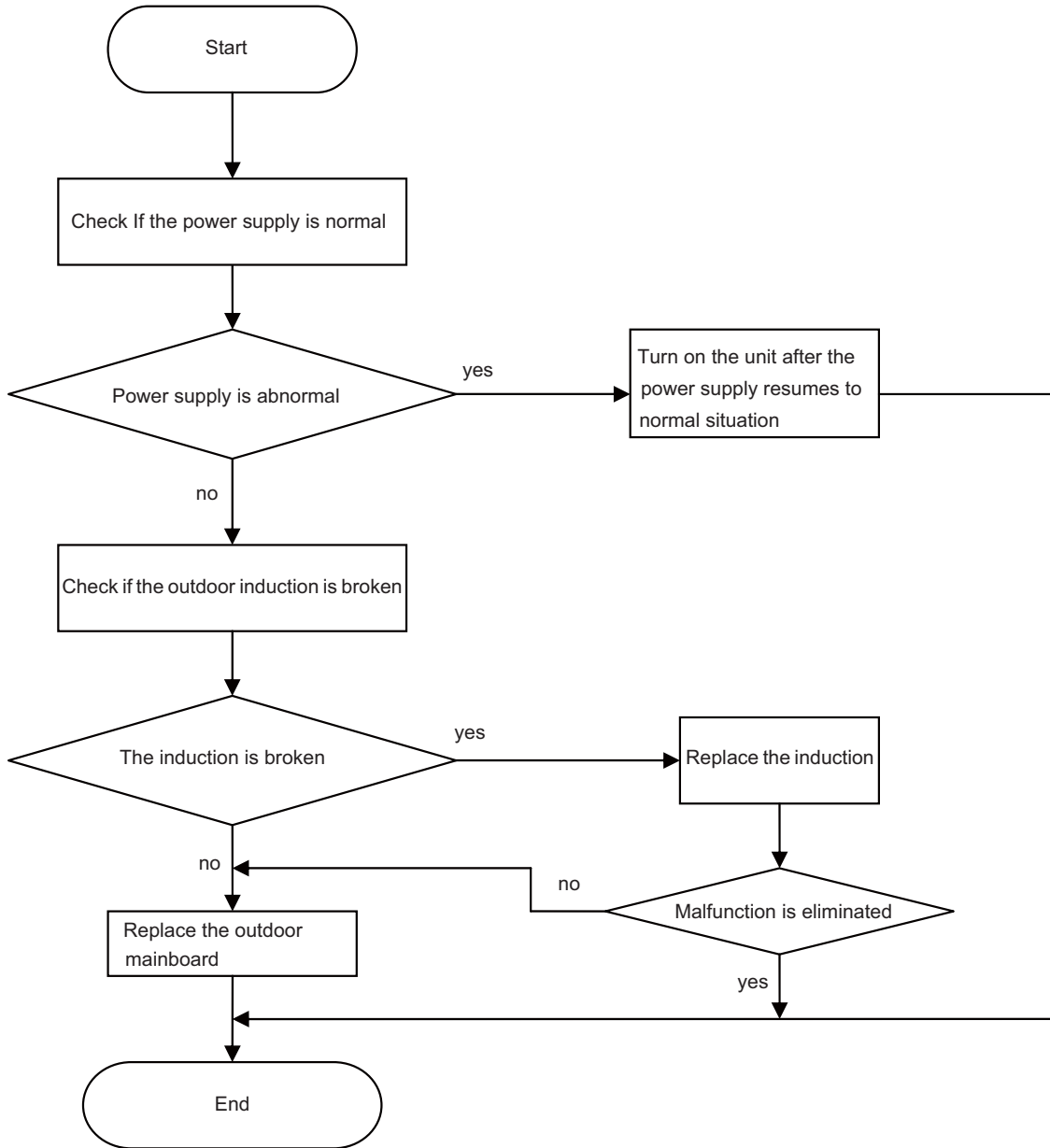

(3) Capacity charging malfunction

Main checking points:

- If the wiring of the induction is connected well and if the induction is broken;
- If the mainboard is broken;

Flow chart:

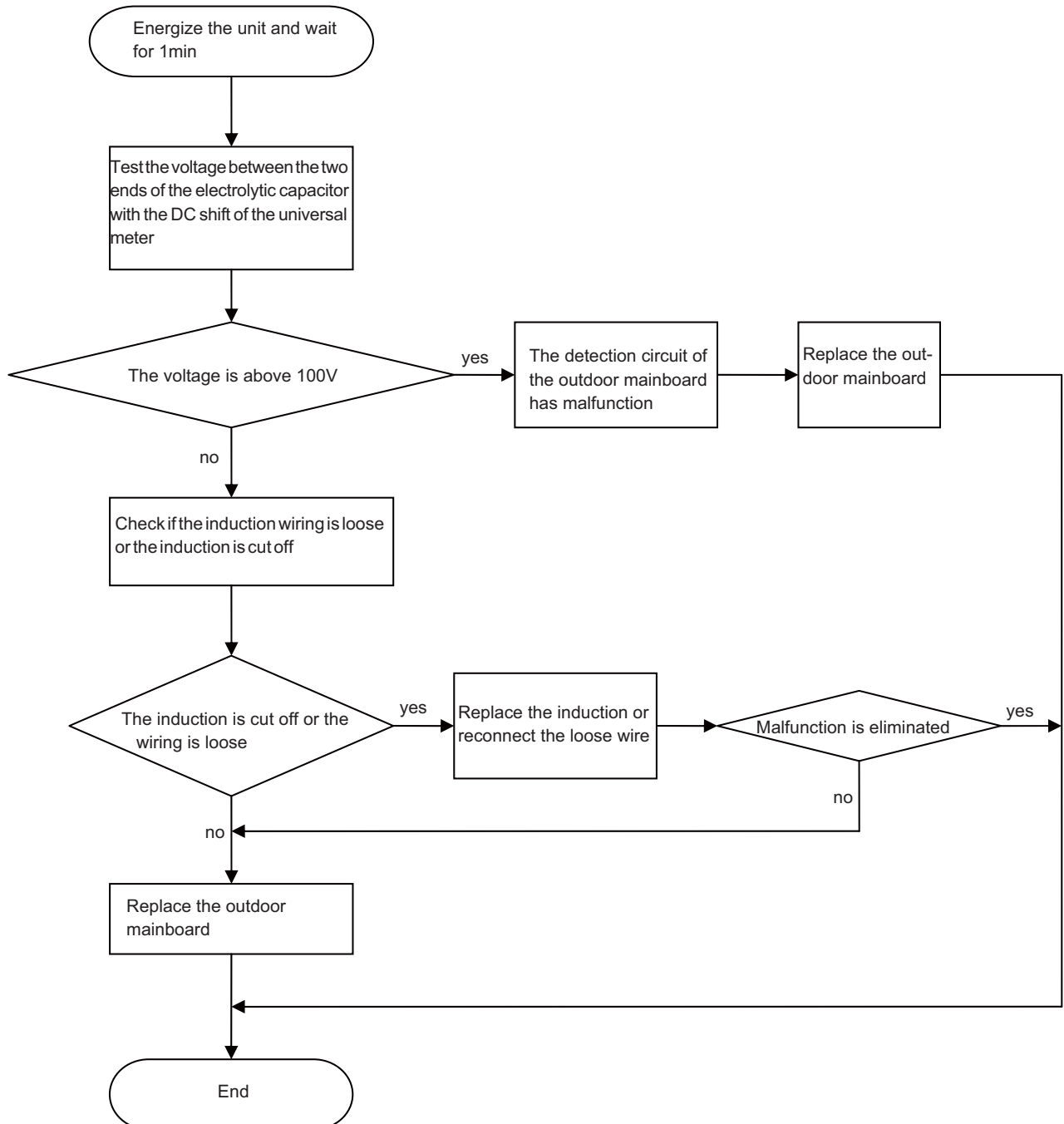

(4) Anti-high temperature and overload malfunction

Main checking points:

- If the outdoor ambient temperature is within the normal range;
- If the outdoor fan is running normally;
- If the indoor and outdoor radiation environment is good;

Flow chart:

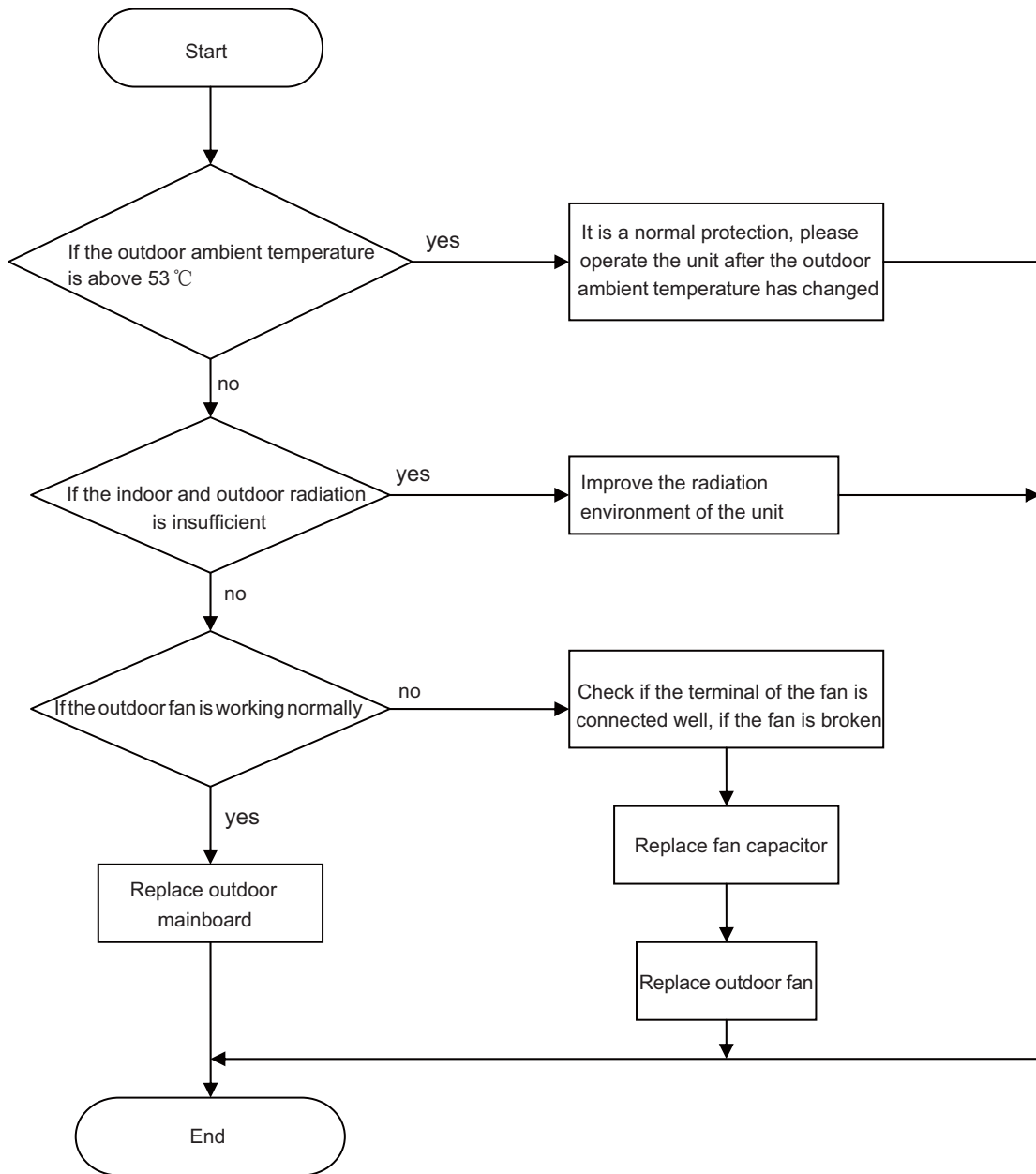

(5) Temperature sensor malfunction

Main checking points:

- If the temperature sensor is damaged or broken
- If the terminal of the temperature sensor is loosened or not connected;
- If the mainboard is broken;

Flow chart:

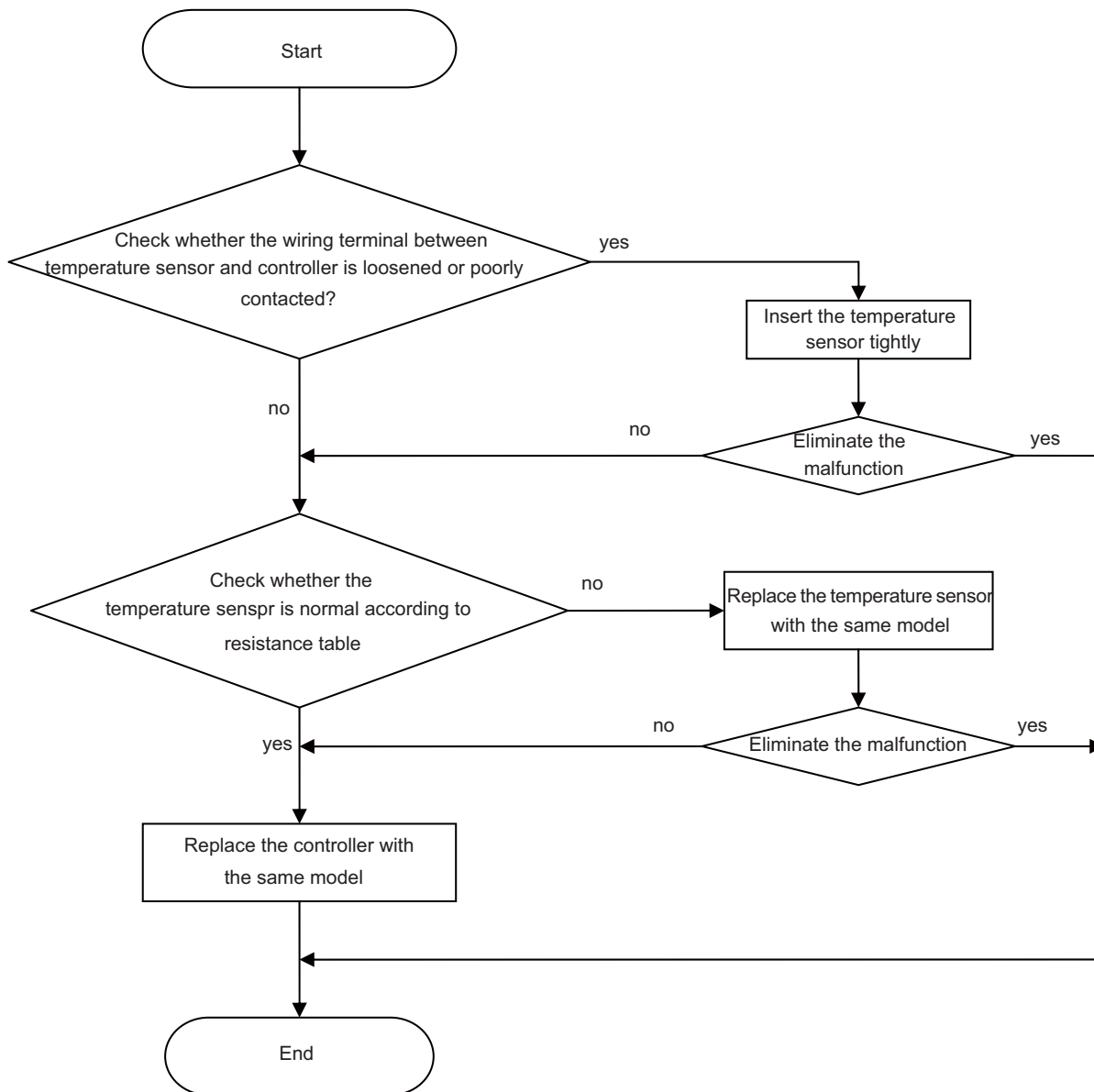

(6) Start failure malfunction

Main checking points:

- If the connection wire of the compressor is connected properly;
- If the stop duration of the compressor is sufficient;
- If the compressor is broken;
- If the refrigerant charging amount is too much;

Flow chart:

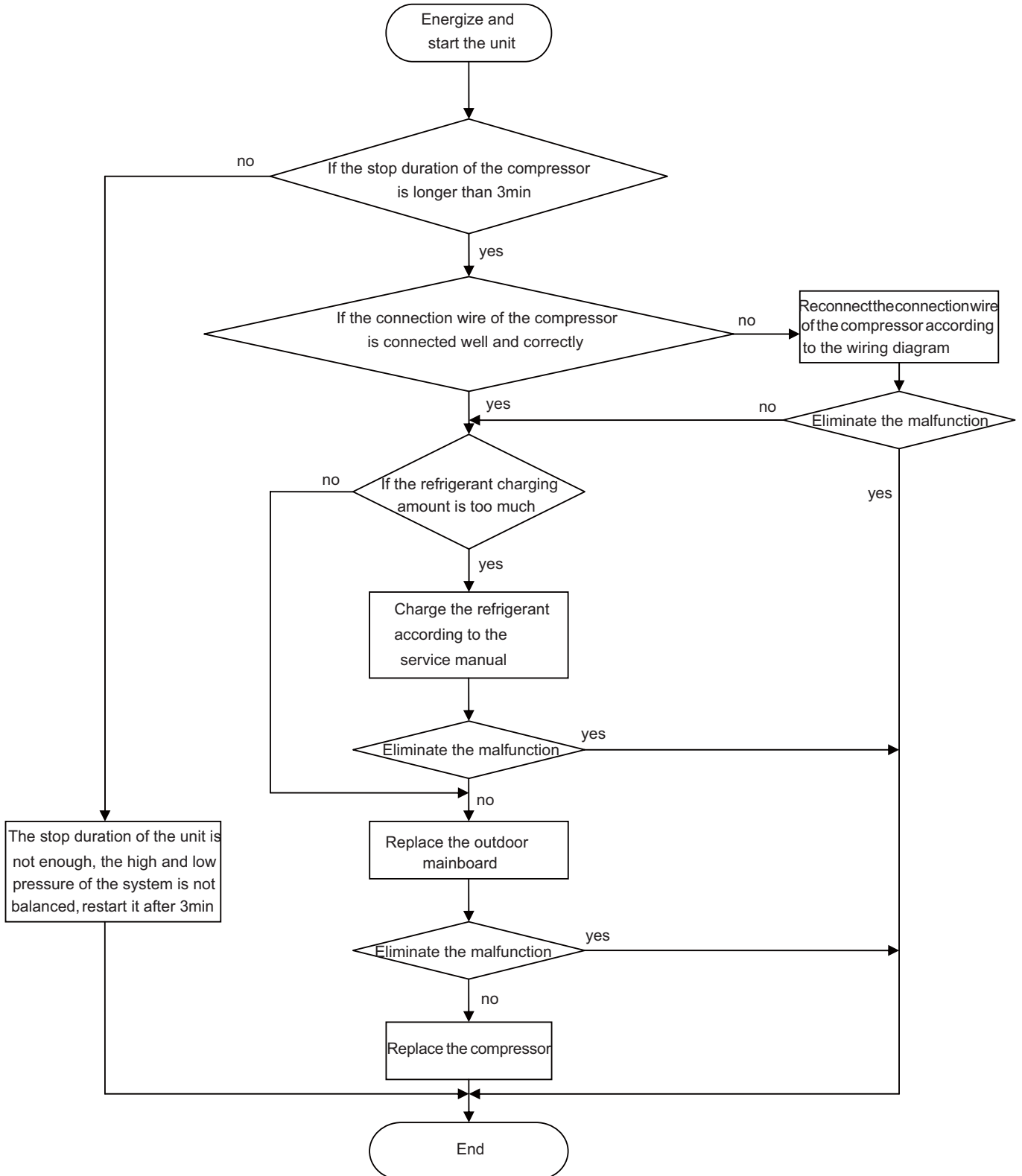

(7) Communication malfunction

Main checking points:

- If the connection wire between the indoor unit and outdoor unit is connected well, if the wires inside the unit is connected well;
- If the indoor mainboard or outdoor main board is broken;

Flow chart:

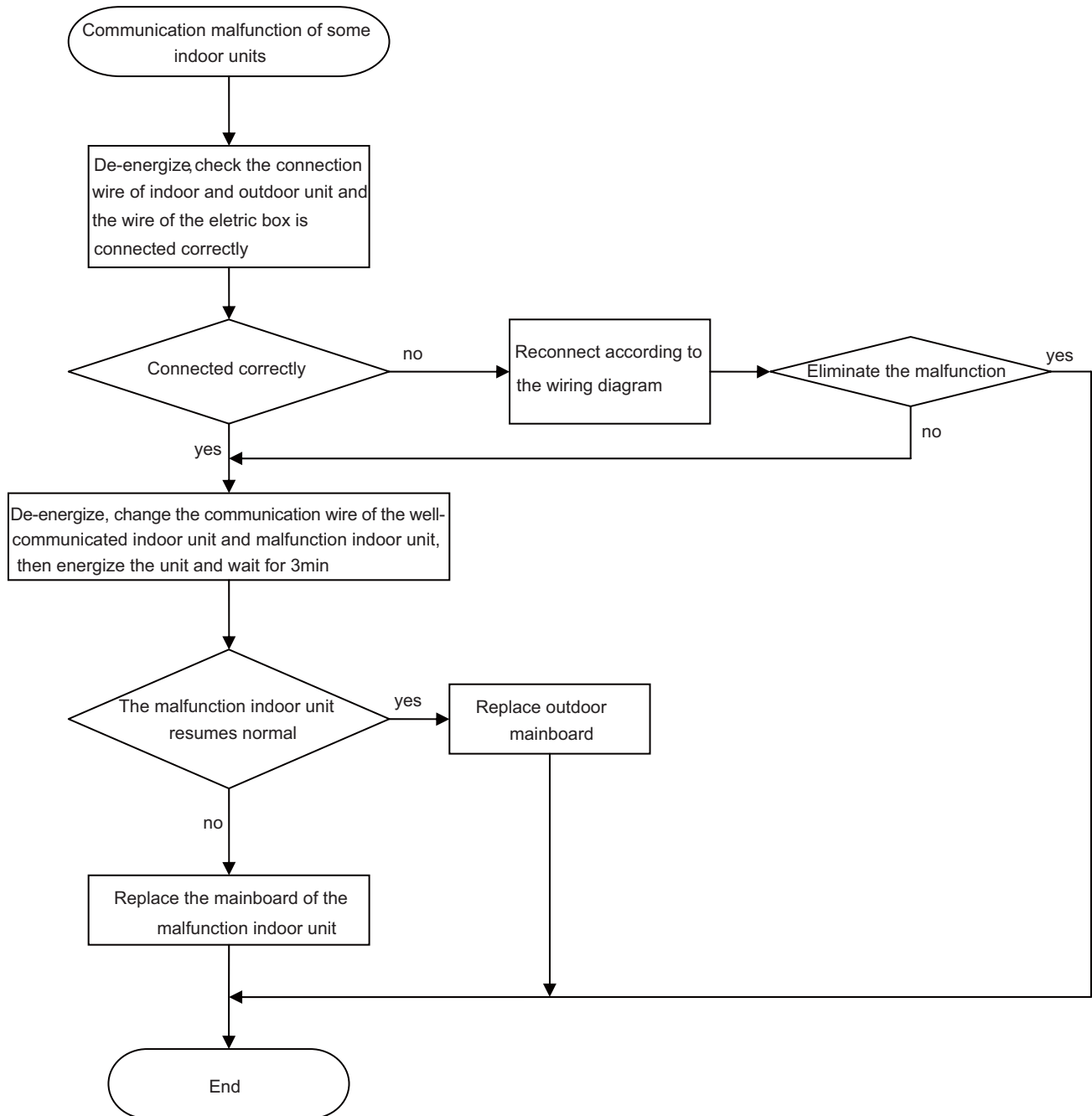

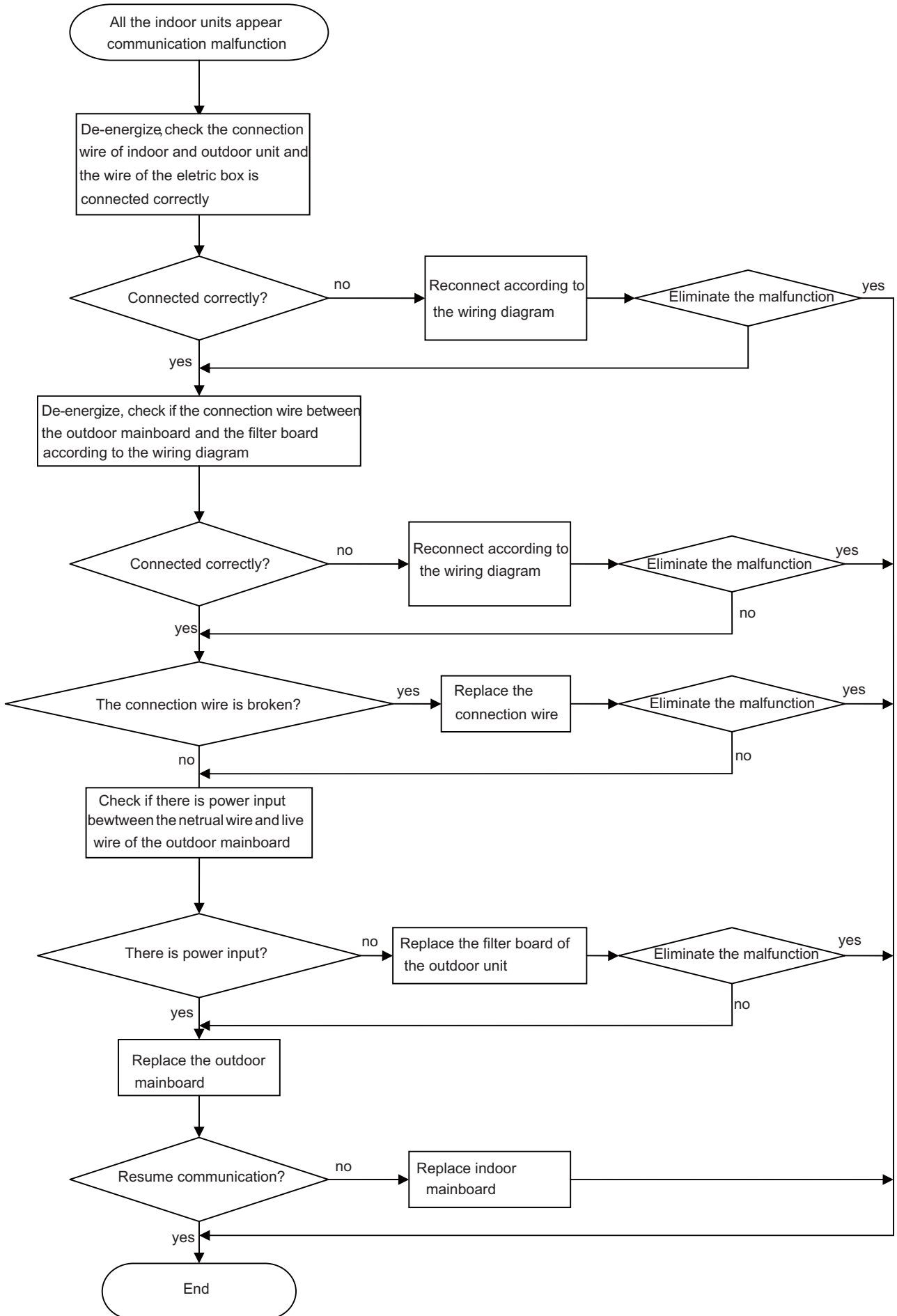

(8) Compressor overload, discharge protection malfunction

Main checking points:

- If the electric expansion valve is connected well or it is broken;
- If there is refrigerant leakage;
- If the overload protector is broken;

Flow chart:

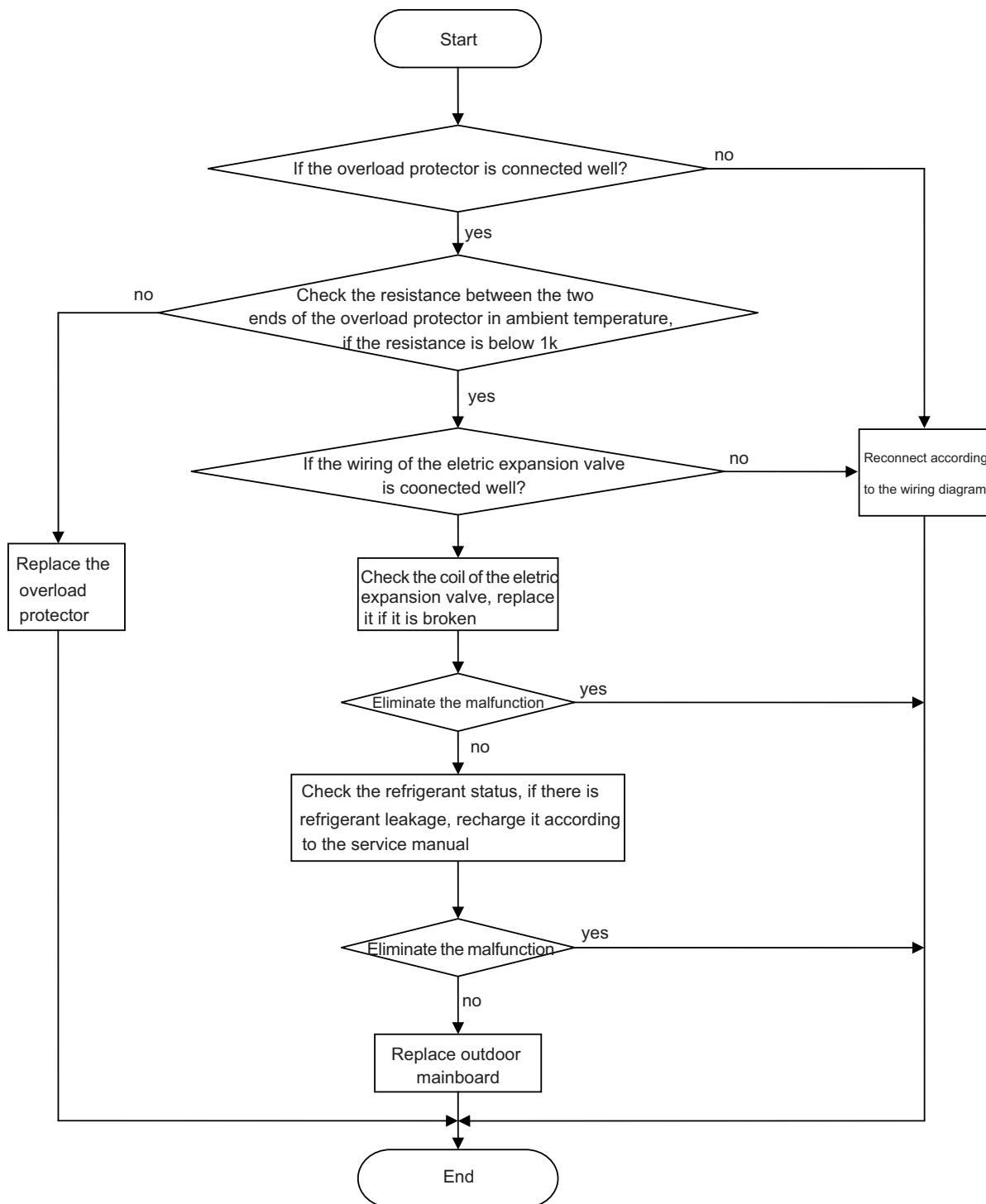

Noted: the detection method of the coil of the electric expansion valve: there is five pieces of the coil of the electric expansion valve, the resistance of one of them (the leftmost or the rightmost one) is almost the same as the resistance of other terminal (within 100 Ω). Judge the condition of the electronic expansion valve through detecting these resistance.

(9) Compressor desynchronizing malfunction

Main checking points:

- If the pressure of the system is too high;
- If the electric expansion valve is working normally or it is broken;
- If the radiation of the unit is good;

Flow chart:

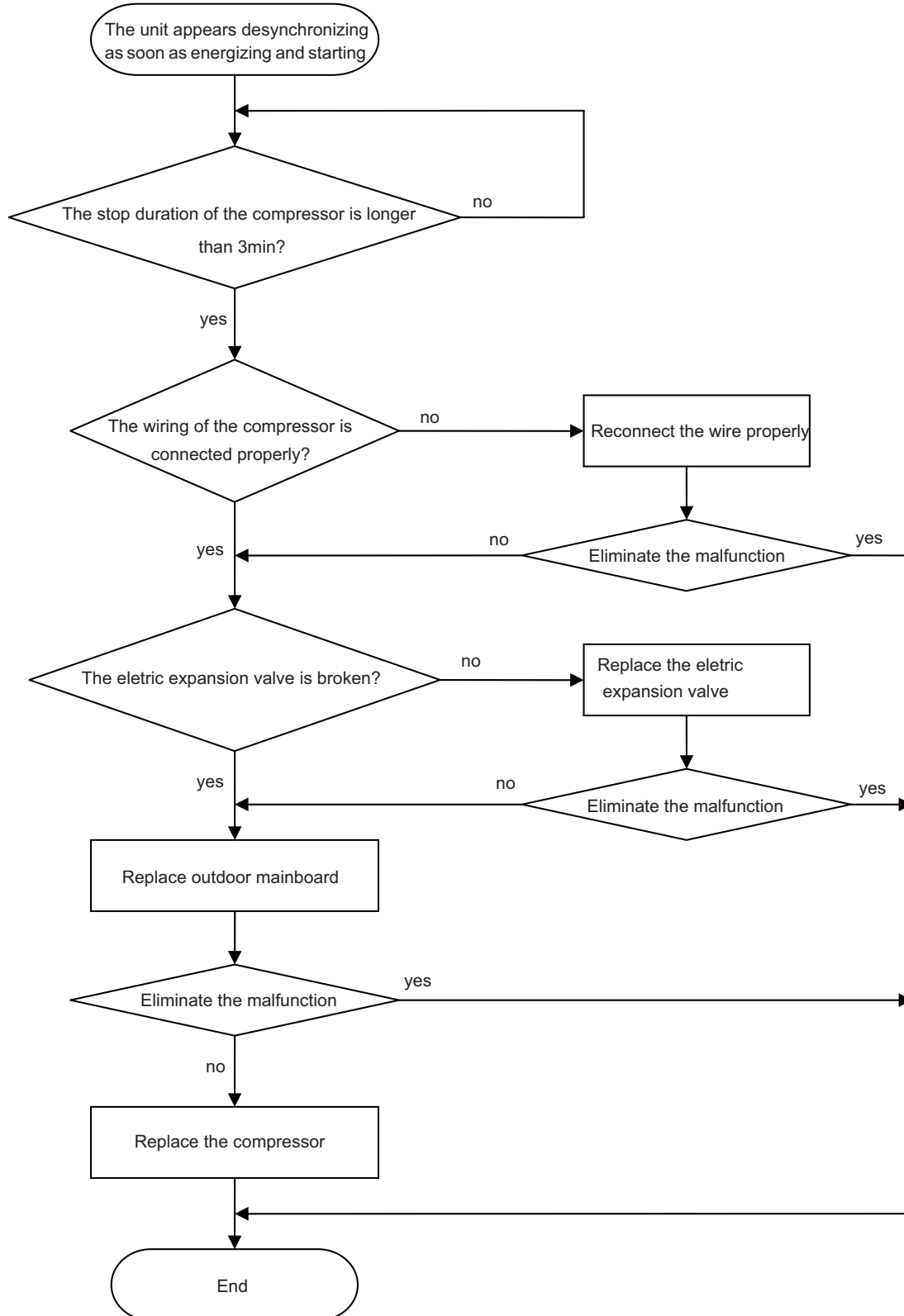

Appendix 1: Resistance Table of Ambient Temperature Sensor for Indoor and Outdoor Units(15K)

Temp(℃)	Resistance(kΩ)	Temp(℃)	Resistance(kΩ)	Temp(℃)	Resistance(kΩ)	Temp(℃)	Resistance(kΩ)
-19	138.1	20	18.75	59	3.848	98	1.071
-18	128.6	21	17.93	60	3.711	99	1.039
-17	121.6	22	17.14	61	3.579	100	1.009
-16	115	23	16.39	62	3.454	101	0.98
-15	108.7	24	15.68	63	3.333	102	0.952
-14	102.9	25	15	64	3.217	103	0.925
-13	97.4	26	14.36	65	3.105	104	0.898
-12	92.22	27	13.74	66	2.998	105	0.873
-11	87.35	28	13.16	67	2.896	106	0.848
-10	82.75	29	12.6	68	2.797	107	0.825
-9	78.43	30	12.07	69	2.702	108	0.802
-8	74.35	31	11.57	70	2.611	109	0.779
-7	70.5	32	11.09	71	2.523	110	0.758
-6	66.88	33	10.63	72	2.439	111	0.737
-5	63.46	34	10.2	73	2.358	112	0.717
-4	60.23	35	9.779	74	2.28	113	0.697
-3	57.18	36	9.382	75	2.206	114	0.678
-2	54.31	37	9.003	76	2.133	115	0.66
-1	51.59	38	8.642	77	2.064	116	0.642
0	49.02	39	8.297	78	1.997	117	0.625
1	46.6	40	7.967	79	1.933	118	0.608
2	44.31	41	7.653	80	1.871	119	0.592
3	42.14	42	7.352	81	1.811	120	0.577
4	40.09	43	7.065	82	1.754	121	0.561
5	38.15	44	6.791	83	1.699	122	0.547
6	36.32	45	6.529	84	1.645	123	0.532
7	34.58	46	6.278	85	1.594	124	0.519
8	32.94	47	6.038	86	1.544	125	0.505
9	31.38	48	5.809	87	1.497	126	0.492
10	29.9	49	5.589	88	1.451	127	0.48
11	28.51	50	5.379	89	1.408	128	0.467
12	27.18	51	5.197	90	1.363	129	0.456
13	25.92	52	4.986	91	1.322	130	0.444
14	24.73	53	4.802	92	1.282	131	0.433
15	23.6	54	4.625	93	1.244	132	0.422
16	22.53	55	4.456	94	1.207	133	0.412
17	21.51	56	4.294	95	1.171	134	0.401
18	20.54	57	4.139	96	1.136	135	0.391
19	19.63	58	3.99	97	1.103	136	0.382

Appendix 2: Resistance Table of Outdoor and Indoor Tube Temperature Sensors(20K)

Temp(°C)	Resistance(kΩ)	Temp(°C)	Resistance(kΩ)	Temp(°C)	Resistance(kΩ)	Temp(°C)	Resistance(kΩ)
-19	181.4	20	25.01	59	5.13	98	1.427
-18	171.4	21	23.9	60	4.948	99	1.386
-17	162.1	22	22.85	61	4.773	100	1.346
-16	153.3	23	21.85	62	4.605	101	1.307
-15	145	24	20.9	63	4.443	102	1.269
-14	137.2	25	20	64	4.289	103	1.233
-13	129.9	26	19.14	65	4.14	104	1.198
-12	123	27	18.13	66	3.998	105	1.164
-11	116.5	28	17.55	67	3.861	106	1.131
-10	110.3	29	16.8	68	3.729	107	1.099
-9	104.6	30	16.1	69	3.603	108	1.069
-8	99.13	31	15.43	70	3.481	109	1.039
-7	94	32	14.79	71	3.364	110	1.01
-6	89.17	33	14.18	72	3.252	111	0.983
-5	84.61	34	13.59	73	3.144	112	0.956
-4	80.31	35	13.04	74	3.04	113	0.93
-3	76.24	36	12.51	75	2.94	114	0.904
-2	72.41	37	12	76	2.844	115	0.88
-1	68.79	38	11.52	77	2.752	116	0.856
0	65.37	39	11.06	78	2.663	117	0.833
1	62.13	40	10.62	79	2.577	118	0.811
2	59.08	41	10.2	80	2.495	119	0.77
3	56.19	42	9.803	81	2.415	120	0.769
4	53.46	43	9.42	82	2.339	121	0.746
5	50.87	44	9.054	83	2.265	122	0.729
6	48.42	45	8.705	84	2.194	123	0.71
7	46.11	46	8.37	85	2.125	124	0.692
8	43.92	47	8.051	86	2.059	125	0.674
9	41.84	48	7.745	87	1.996	126	0.658
10	39.87	49	7.453	88	1.934	127	0.64
11	38.01	50	7.173	89	1.875	128	0.623
12	36.24	51	6.905	90	1.818	129	0.607
13	34.57	52	6.648	91	1.736	130	0.592
14	32.98	53	6.403	92	1.71	131	0.577
15	31.47	54	6.167	93	1.658	132	0.563
16	30.04	55	5.942	94	1.609	133	0.549
17	28.68	56	5.726	95	1.561	134	0.535
18	27.39	57	5.519	96	1.515	135	0.521
19	26.17	58	5.32	97	1.47	136	0.509

Appendix3: Resistance Table for Outdoor Discharge Temperature Sensor (50K)

Temp(°C)	Resistance(kΩ)	Temp(°C)	Resistance(kΩ)	Temp(°C)	Resistance(kΩ)	Temp(°C)	Resistance(kΩ)
-29	853.5	10	98	49	18.34	88	4.75
-28	799.8	11	93.42	50	17.65	89	4.61
-27	750	12	89.07	51	16.99	90	4.47
-26	703.8	13	84.95	52	16.36	91	4.33
-25	660.8	14	81.05	53	15.75	92	4.20
-24	620.8	15	77.35	54	15.17	93	4.08
-23	580.6	16	73.83	55	14.62	94	3.96
-22	548.9	17	70.5	56	14.09	95	3.84
-21	516.6	18	67.34	57	13.58	96	3.73
-20	486.5	19	64.33	58	13.09	97	3.62
-19	458.3	20	61.48	59	12.62	98	3.51
-18	432	21	58.77	60	12.17	99	3.41
-17	407.4	22	56.19	61	11.74	100	3.32
-16	384.5	23	53.74	62	11.32	101	3.22
-15	362.9	24	51.41	63	10.93	102	3.13
-14	342.8	25	49.19	64	10.54	103	3.04
-13	323.9	26	47.08	65	10.18	104	2.96
-12	306.2	27	45.07	66	9.83	105	2.87
-11	289.6	28	43.16	67	9.49	106	2.79
-10	274	29	41.34	68	9.17	107	2.72
-9	259.3	30	39.61	69	8.85	108	2.64
-8	245.6	31	37.96	70	8.56	109	2.57
-7	232.6	32	36.38	71	8.27	110	2.50
-6	220.5	33	34.88	72	7.99	111	2.43
-5	209	34	33.45	73	7.73	112	2.37
-4	198.3	35	32.09	74	7.47	113	2.30
-3	199.1	36	30.79	75	7.22	114	2.24
-2	178.5	37	29.54	76	7.00	115	2.18
-1	169.5	38	28.36	77	6.76	116	2.12
0	161	39	27.23	78	6.54	117	2.07
1	153	40	26.15	79	6.33	118	2.02
2	145.4	41	25.11	80	6.13	119	1.96
3	138.3	42	24.13	81	5.93	120	1.91
4	131.5	43	23.19	82	5.75	121	1.86
5	125.1	44	22.29	83	5.57	122	1.82
6	119.1	45	21.43	84	5.39	123	1.77
7	113.4	46	20.6	85	5.22	124	1.73
8	108	47	19.81	86	5.06	125	1.68
9	102.8	48	19.06	87	4.90	126	1.64

Note: The information above is for reference only.

10. Removal Procedure



Warning

Be sure to wait for a minimum of 10 minutes after turning off all power supplies before disassembly.

(1) Models: GWHD(14)NK3BO, GWHD(18)NK3DO

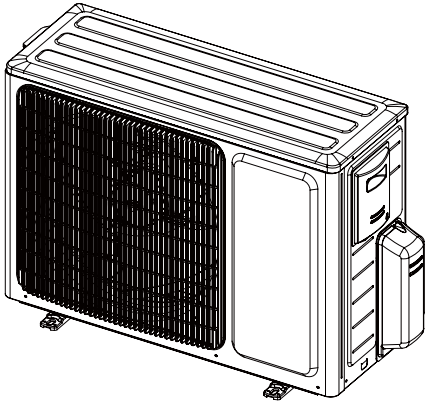
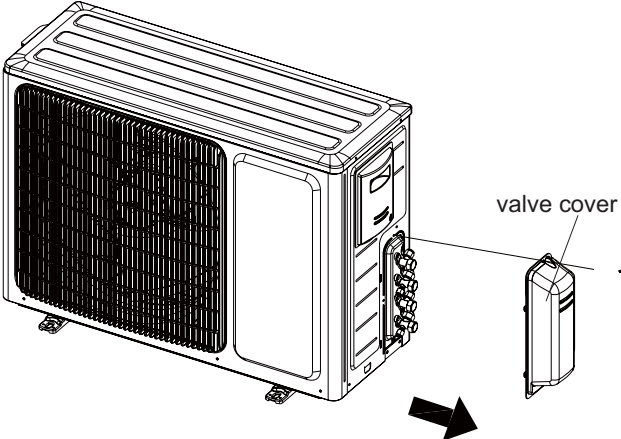
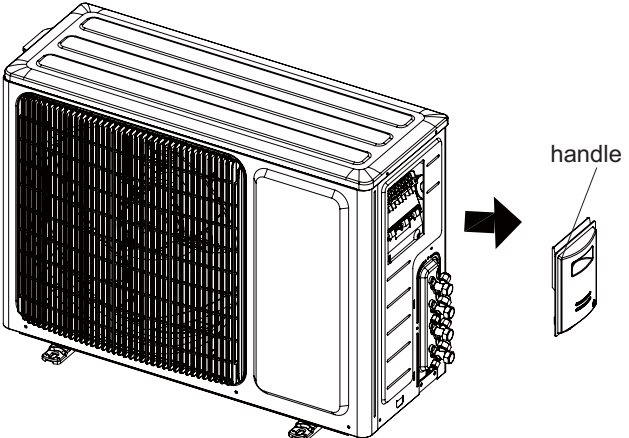
Steps	Procedure
1. Before disassembly	<p data-bbox="215 745 555 775">Complete axonometric drawing.</p> 
2. Remove valve cover	<p data-bbox="215 1234 724 1290">Remove the connection screw fixing the valve cover and then remove the valve cover.</p> 
3. Remove handle	<p data-bbox="215 1760 724 1843">Remove the connection screw fixing the handle and the right side plate, and then remove the handle.</p> 

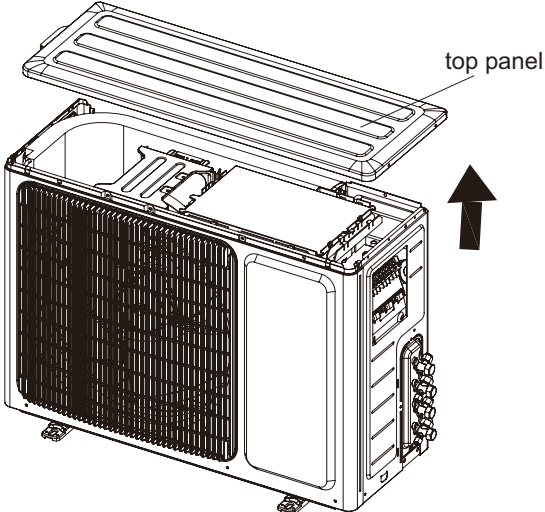
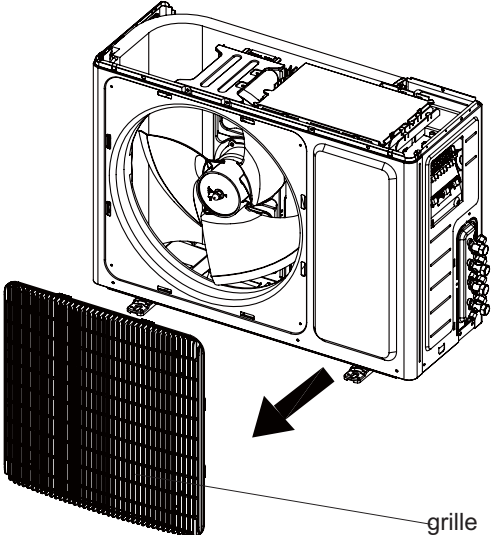
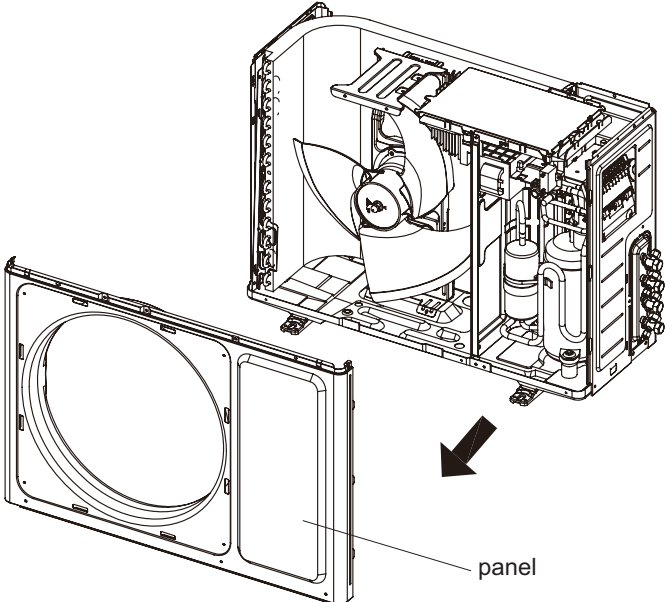
Steps	Procedure
4. Remove top panel	<p>Remove the connection screws connecting the top panel and the front panel, and then remove the top panel.</p> 
5. Remove front grille	<p>Remove the connection screws connecting the front grille and the front panel, and then loosen the clasp to remove the front grille.</p> 
6. Remove front panel	<p>Remove the screws connecting the front panel and then remove the front panel.</p> 

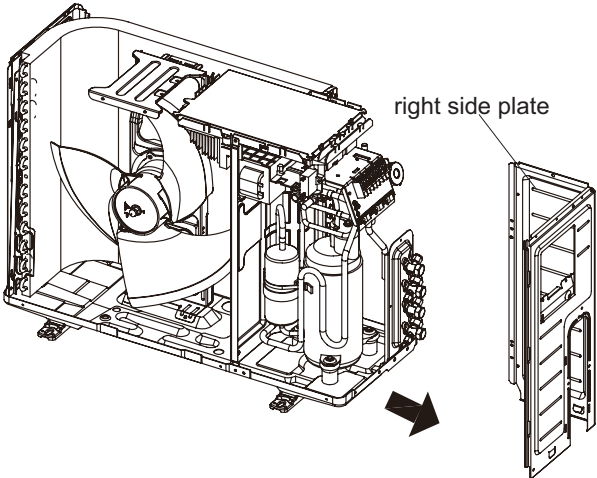
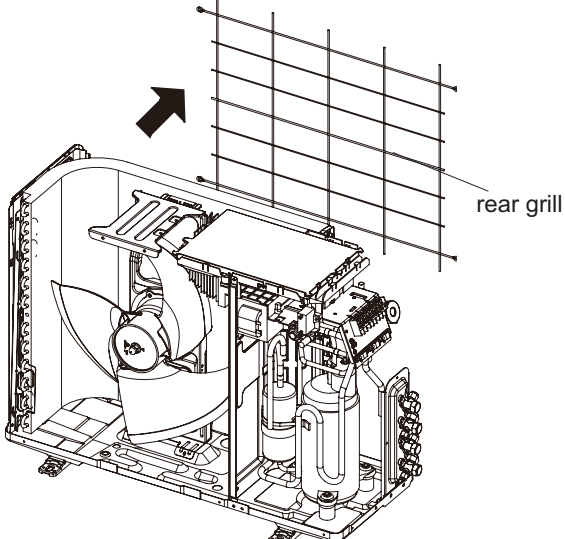
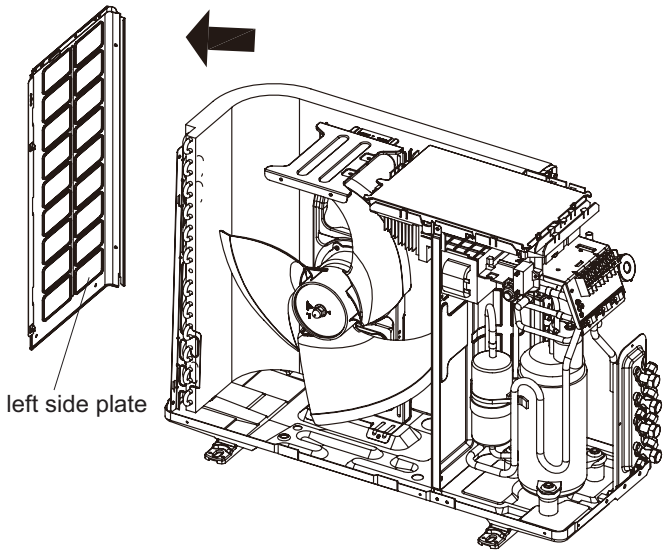
Steps	Procedure
<p>7. Remove right side plate</p>	<p>Remove the screws connecting the right side plate with the chassis and the valve support. Then remove the right side plate.</p>  <p>right side plate</p>
<p>8. Remove rear grill</p>	<p>Remove the screws connecting the rear grill and left side plate, and then remove the rear grill.</p>  <p>rear grill</p>
<p>9. Remove left side plate</p>	<p>Remove the screws fixing the left side plate with the chassis and the condenser support, and then remove the left side plate.</p>  <p>left side plate</p>

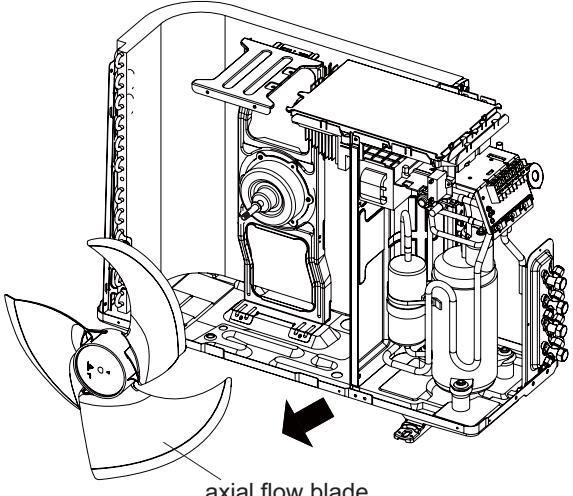
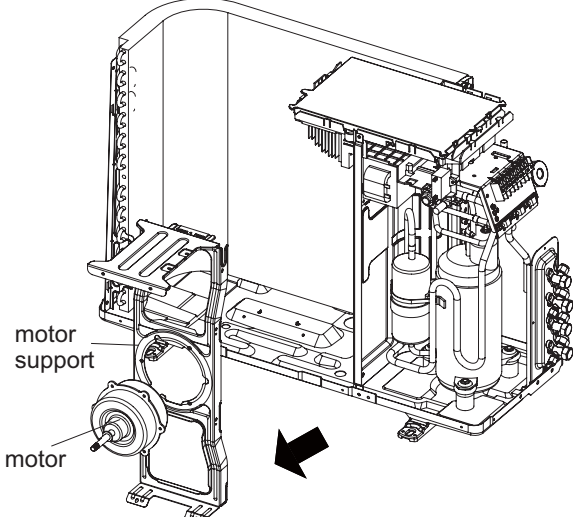
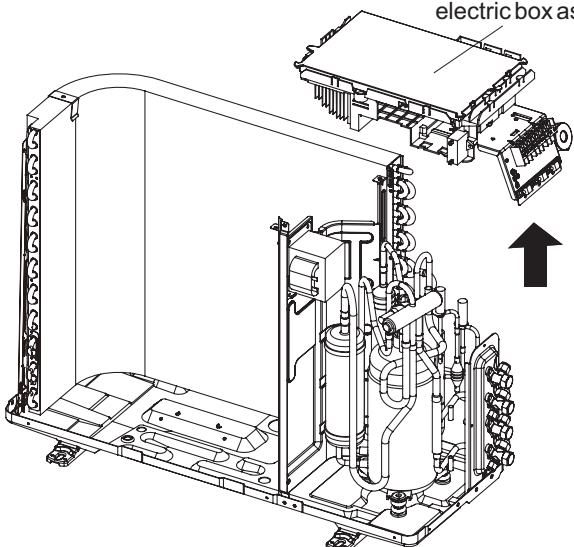
Steps	Procedure
10. Remove axial flow blade	<p data-bbox="209 555 719 629">Remove the nut on the blade and then remove the axial flow blade.</p>  <p data-bbox="1082 835 1246 864">axial flow blade</p>
11. Remove motor and motor support	<p data-bbox="209 1077 719 1312">Remove the 4 tapping screws fixing the motor and disconnect the leading wire insert of the motor. Then remove the motor. Remove the 2 tapping screws fixing the motor support and chassis, and then lift the motor support to remove it.</p>  <p data-bbox="842 1216 927 1245">motor support</p> <p data-bbox="842 1339 895 1368">motor</p>
12. Remove electric box assy	<p data-bbox="209 1653 719 1805">Remove the screws fixing the electric box assy and the middle isolation sheet, loosen the wire bundle, unplug the wiring terminals, and then lift the electric box assy to remove it.</p>  <p data-bbox="1326 1473 1501 1503">electric box assy</p>

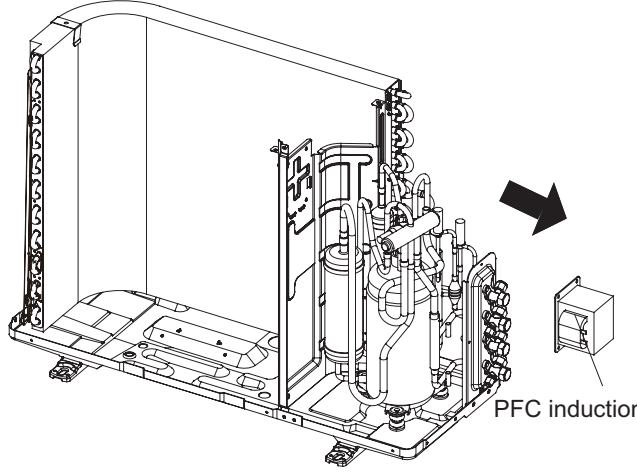
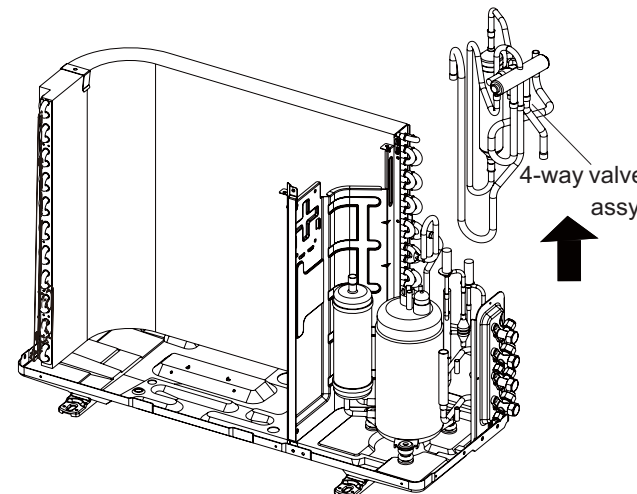
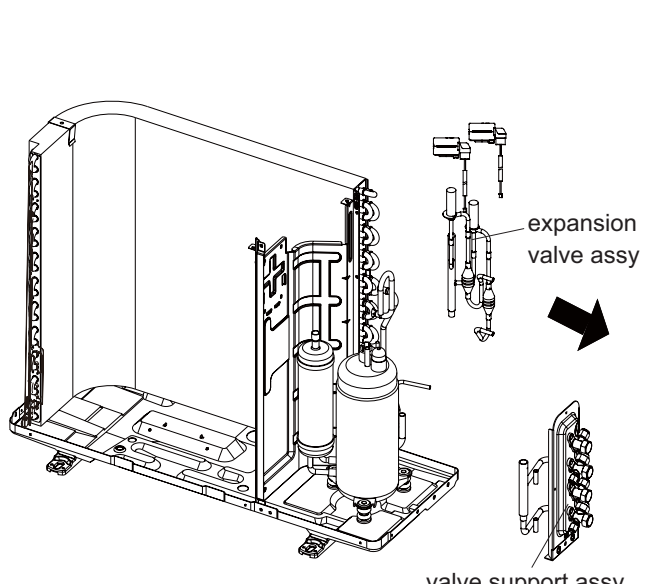
Steps	Procedure
13. Remove PFC induction	<p>Remove the screw connecting the PFC induction and middle isolation sheet, and then remove the PFC induction.</p>  <p>PFC induction</p>
14. Remove 4-way valve assy	<p>Unsolder the welding joint connecting the 4-way valve assy with compressor suction and discharge port, the valve with the outlet pipe of condenser. Then lift the 4-way valve assy to remove it. (NOTE: Discharge the refrigerant completely before unsoldering.)</p>  <p>4-way valve assy</p>
15. Remove valve support sub-assy and expansion valve assy	<p>Remove the screw connecting the valve support and the chassis, and then remove the valve support assy. Unsolder the welding joint connecting the electronic expansion valve assy with the cut-off valve and the condenser connection pipe, and then remove the expansion valve assy.</p>  <p>expansion valve assy</p> <p>valve support assy</p>

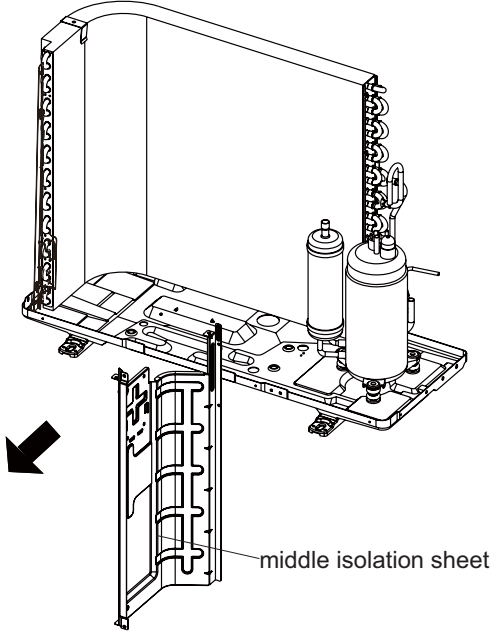
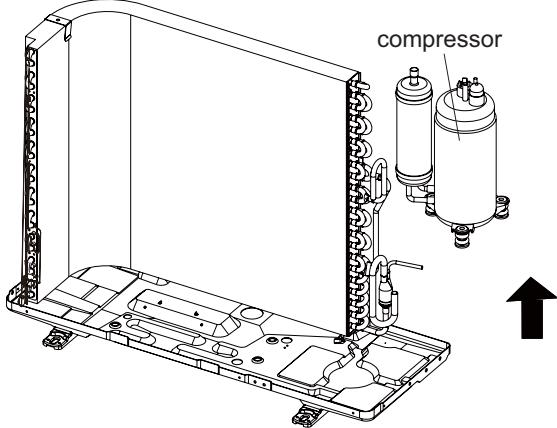
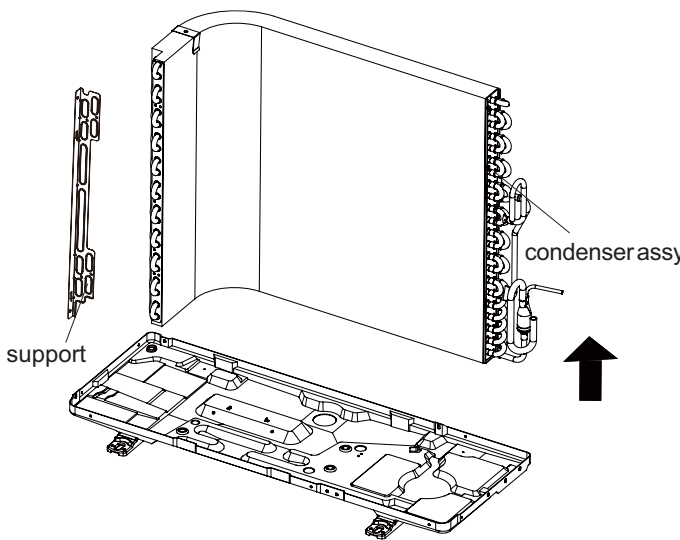
Steps	Procedure
<p>16. Remove middle isolation sheet</p>	<p>Remove the screws connecting the middle isolation sheet with the chassis assy and the condenser assy, and then remove the middle isolation sheet.</p> 
<p>17. Remove compressor</p>	<p>Remove the 3 foot nuts fixing the compressor and then remove the compressor.</p> 
<p>18. Remove condenser assy</p>	<p>Remove the screws fixing the condenser support and then remove the condenser support. Remove the screws connecting the condenser support and the chassis assy, and then remove the condenser assy.</p> 

(2) Take GWHD(28)NK3BO for example.



Warning

Be sure to wait for a minimum of 10 minutes after turning off all power supplies before disassembly.

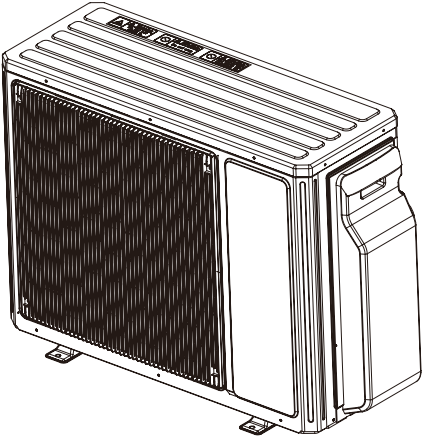
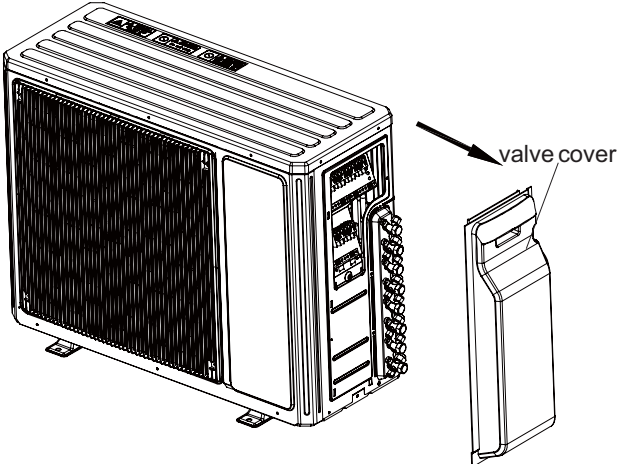
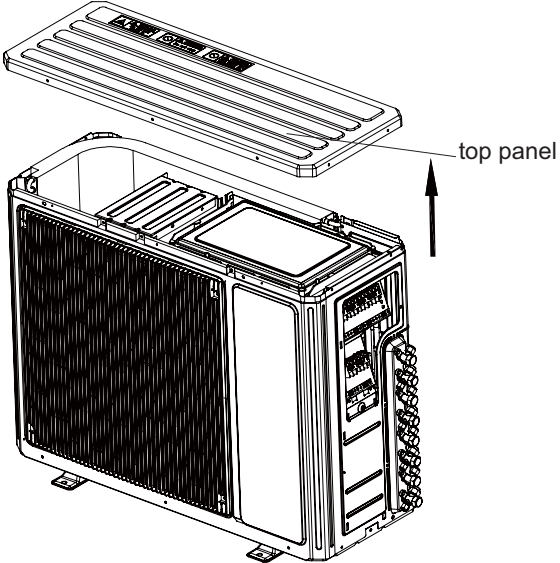
Steps	Procedure
1. Before disassembly	<p data-bbox="213 656 553 685">Complete axonometric drawing.</p> 
2. Remove valve cover	<p data-bbox="213 1128 724 1196">Remove the connection screw fixing the valve cover and then remove the valve cover.</p> 
3. Remove top panel	<p data-bbox="213 1641 724 1753">Remove the connection screws connecting the top panel with the right side plate and the left side plate, and then remove the top panel.</p> 

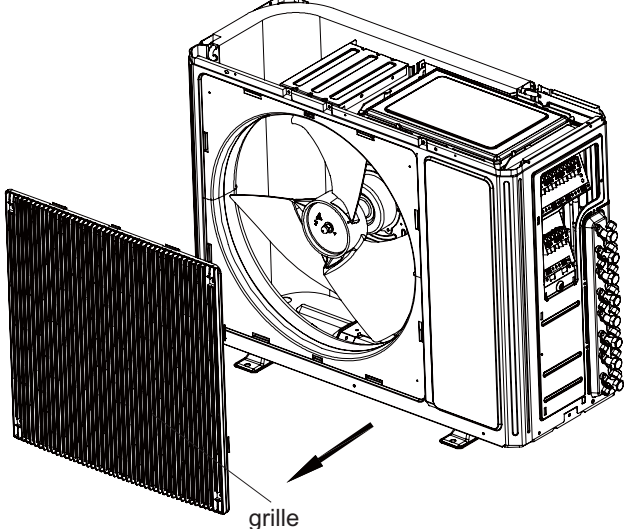
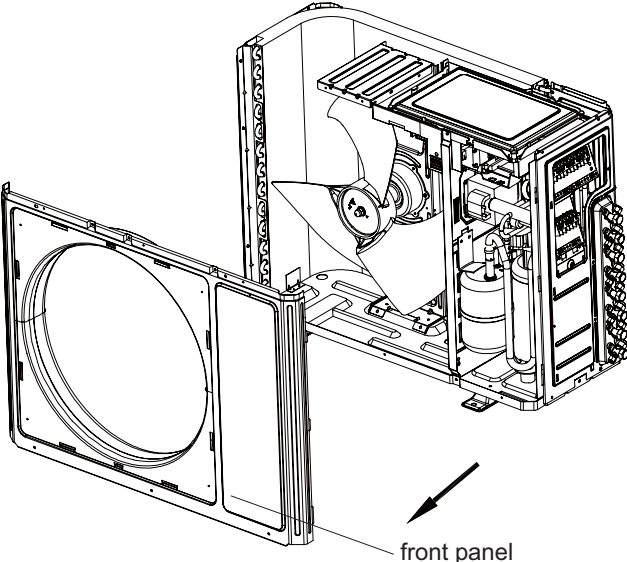
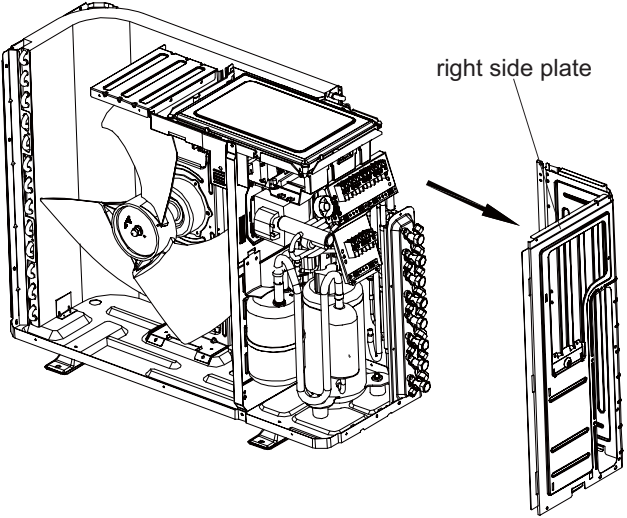
Steps	Procedure	
4. Remove front grille	Remove the connection screws connecting the front grille and the front panel, and then loosen the clasp to remove the front grille.	 <p>The diagram shows a perspective view of the front of the unit. The front grille is shown being pulled away from the front panel. An arrow points to the grille with the label "grille".</p>
5. Remove front panel	Remove the screws connecting the front panel and then remove the front panel.	 <p>The diagram shows a perspective view of the front of the unit. The front panel is shown being pulled away from the unit. An arrow points to the front panel with the label "front panel".</p>
6. Remove right side plate	Remove the screws connecting the right side plate with the chassis and the valve support. Then remove the right side plate.	 <p>The diagram shows a perspective view of the front of the unit. The right side plate is shown being pulled away from the unit. An arrow points to the right side plate with the label "right side plate".</p>

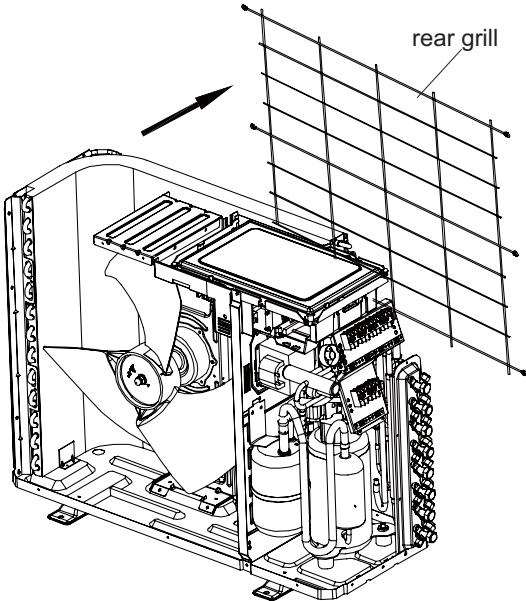
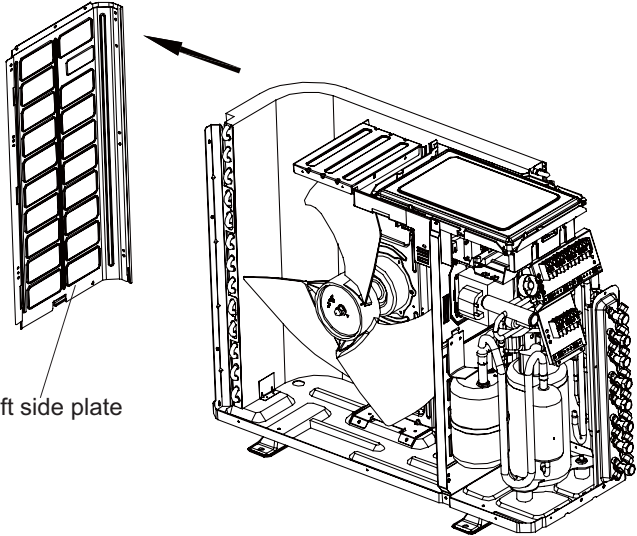
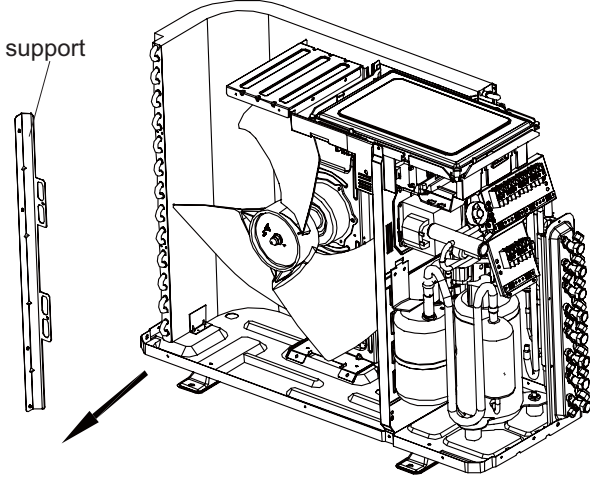
Steps	Procedure
<p>7. Remove rear grill</p>	<p>Remove the screws connecting the rear grill and the left side plate, and then remove the rear grill.</p>  <p>Diagram illustrating the removal of the rear grill. The rear grill is shown being lifted away from the chassis. The rear grill is labeled "rear grill".</p>
<p>8. Remove left side plate</p>	<p>Remove the screws fixing the left side plate with the chassis and the condenser support, and then remove the left side plate.</p>  <p>Diagram illustrating the removal of the left side plate. The left side plate is shown being lifted away from the chassis. The left side plate is labeled "left side plate".</p>
<p>9. Remove condenser support</p>	<p>Remove the connection screws connecting the condenser support and the chassis, and then remove the condenser support.</p>  <p>Diagram illustrating the removal of the condenser support. The condenser support is shown being lifted away from the chassis. The condenser support is labeled "support".</p>

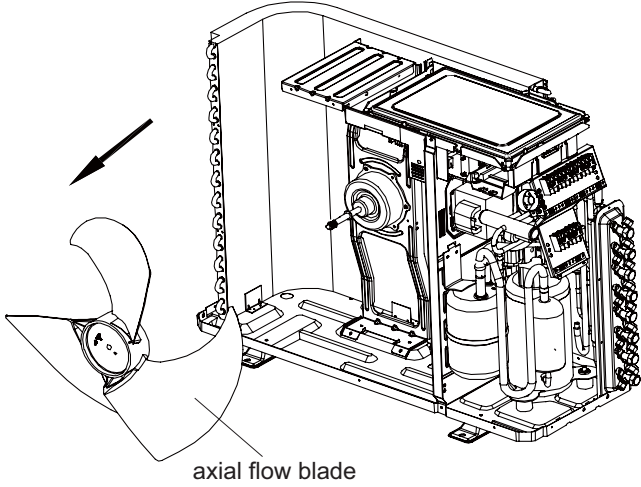
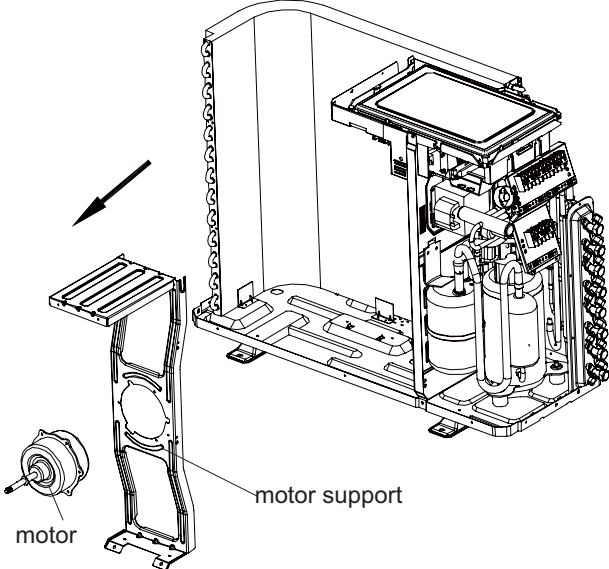
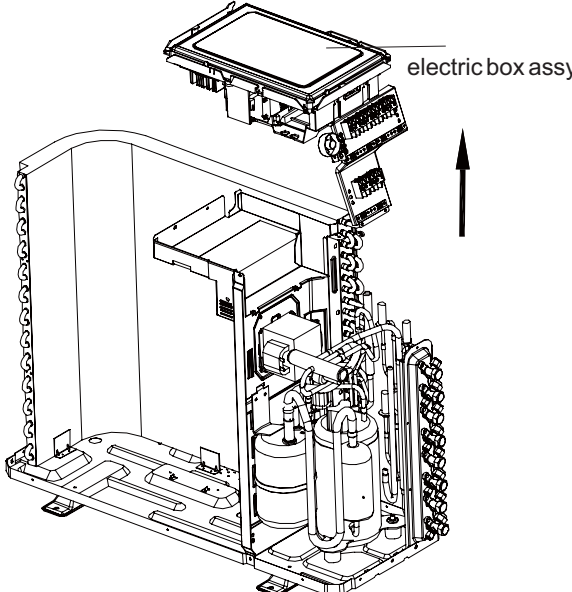
Steps	Procedure
10. Remove axial flow blade	<p data-bbox="225 568 767 622">Remove the nut on the blade and then remove the axial flow blade.</p>  <p data-bbox="1034 786 1203 815">axial flow blade</p>
11. Remove motor and motor support	<p data-bbox="225 1137 767 1281">Remove the 4 tapping screws fixing the motor and disconnect the leading wire insert of the motor. Then remove the motor. Remove the 2 tapping screws fixing the motor support and chassis, and then lift the motor support to remove it.</p>  <p data-bbox="874 1368 943 1397">motor</p> <p data-bbox="1114 1330 1267 1359">motor support</p>
12. Remove electric box assy	<p data-bbox="225 1778 767 1863">Remove the screws fixing the electric box assy and the middle isolation sheet, and then lift the electric box assy to remove it.</p>  <p data-bbox="1337 1509 1506 1538">electric box assy</p>

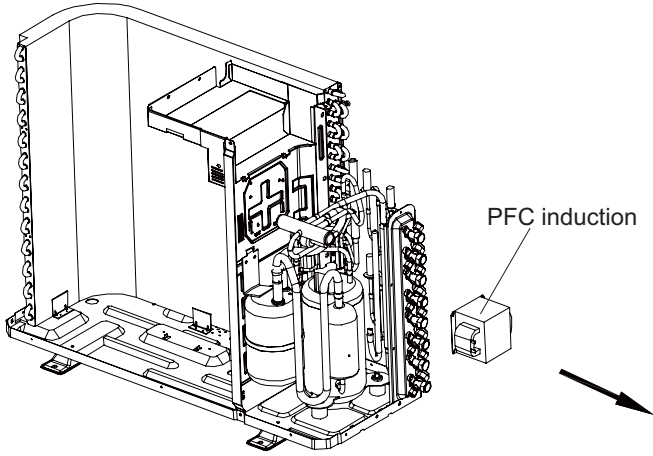
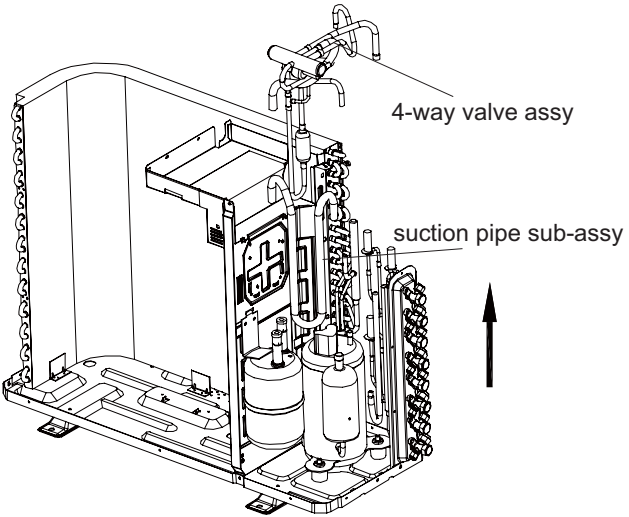
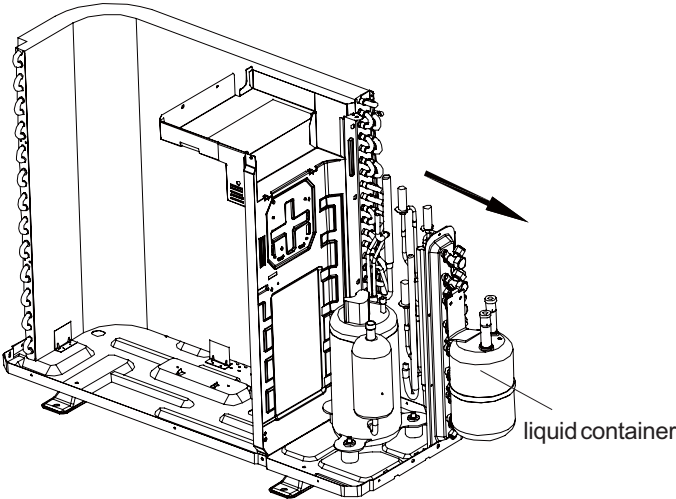
Steps	Procedure
13. Remove PFC induction	<p>Remove the screw connecting the PFC induction and middle isolation sheet, and then remove the PFC induction.</p>  <p>The diagram shows a cutaway view of the unit's internal components. A small rectangular component labeled 'PFC induction' is shown being moved away from the main assembly, indicated by a black arrow pointing to the right.</p>
14. Remove 4-way valve assy and suction pipe sub-assy	<p>Unsolder the welding joint connecting the 4-way valve assy with compressor suction and discharge port, the valve with the outlet pipe of condenser. Then lift the 4-way valve assy to remove it. (NOTE: Discharge the refrigerant completely before unsoldering.) Unsolder the welding joint connecting the suction pipe sub-assy with compressor and liquid container, and then remove the suction pipe sub-assy.</p>  <p>The diagram shows a cutaway view of the unit's internal components. Two components are labeled: '4-way valve assy' and 'suction pipe sub-assy'. A black arrow points upwards, indicating the direction of removal for these components.</p>
15. Remove liquid container	<p>Remove the screws connecting the isolation plate sub-assy and the liquid container, and then lift the liquid container to remove it.</p>  <p>The diagram shows a cutaway view of the unit's internal components. A cylindrical component labeled 'liquid container' is shown being moved away from the main assembly, indicated by a black arrow pointing to the right.</p>

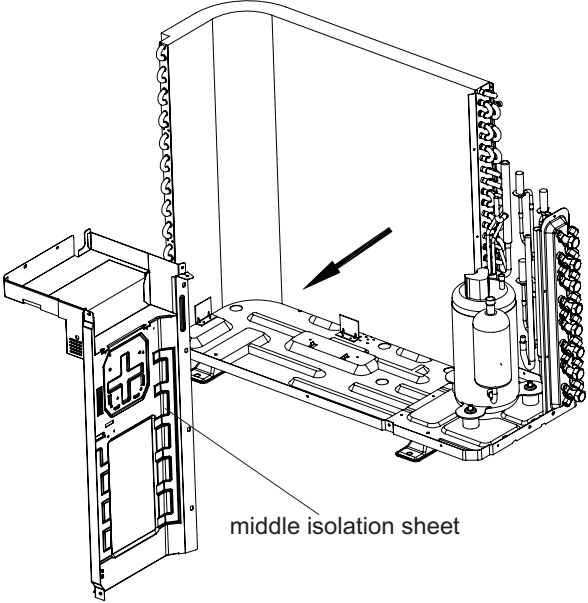
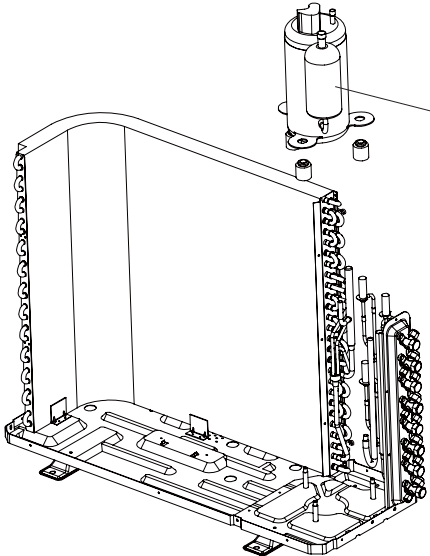
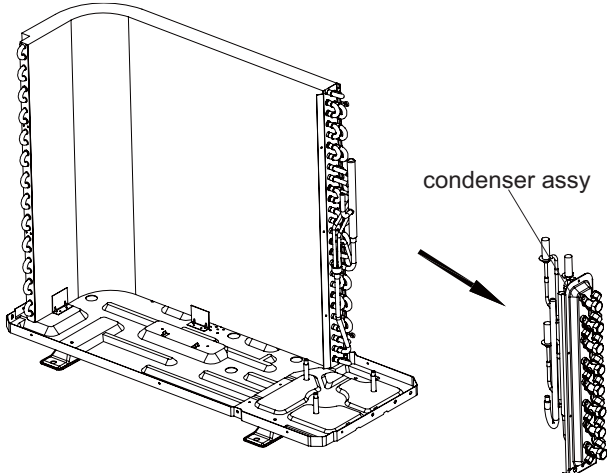
Steps	Procedure	
16. Remove middle isolation sheet	<p>Remove the screws connecting the middle isolation sheet with the chassis assy and the condenser assy, and then remove the middle isolation sheet.</p>	 <p>middle isolation sheet</p>
17. Remove compressor	<p>Remove the 3 foot nuts fixing the compressor and then remove the compressor.</p>	 <p>compressor</p>
18. Remove valve support sub-assy	<p>Remove the screw connecting the valve support assy and the chassis sub-assy, and then remove the valve support assy.</p>	 <p>condenser assy</p>

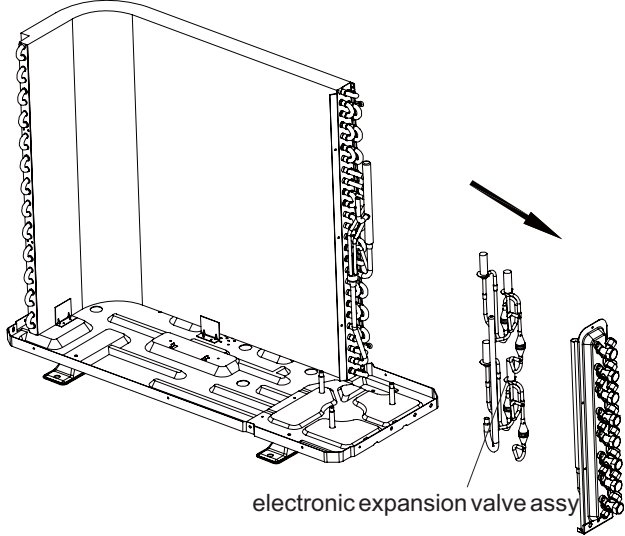
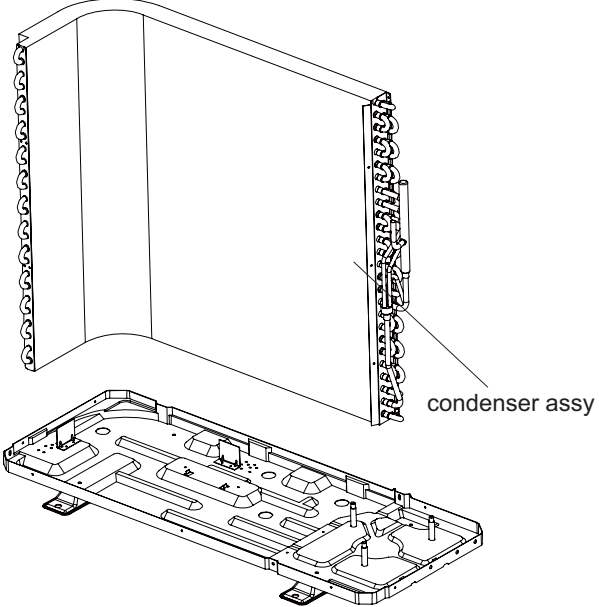
Steps	Procedure
<p>19. Remove electronic expansion valve assy</p>	<p>Unsolder the welding joint connecting the electronic expansion valve sub-assy with the gas collection pipe, and then remove the electronic expansion valve assy. (Note: when unsoldering, wrap the gas valve with a wet cloth completely to avoid damage to the valve caused by high temperature).</p>  <p>electronic expansion valve assy</p>
<p>20. Remove condenser assy</p>	<p>Remove the screws connecting the condenser assy and the chassis assy, and then remove the condenser assy.</p>  <p>condenser assy</p>



GREE ELECTRIC APPLIANCES,INC.OF ZHUHAI

Add:Jinji west Rd.Qianshan Zhuhai Guangdong China

Tel:86-756-8522219 (After Sale Service Dept)

Post code : 519070