



# Service Manual

---

MODEL: GEH(09)AA-K3DNA1B/I  
GEH(12)AA-K3DNA1B/I  
GEH(18)AA-K3DNA1B/I

**GREE ELECTRIC APPLIANCES, INC.OF ZHUHAI**

<b>Summary and features</b> .....	1
<b>Part 1 Safety Precautions</b> .....	2
<b>Part 2 Specifications</b> .....	3
2.1 Unit Specifications.....	3
2.2 Noise criteria curve tables for both models.....	4
<b>Part 3 Construction Views</b> .....	5
<b>Part 4 Refrigerant System Diagram</b> .....	6
<b>Part 5 Schematic Diagram</b> .....	7
5.1 Electrical Data.....	7
5.2 Electrical Wiring.....	7
5.3 Printed Circuit Board.....	8
<b>Part 6 Function and Control</b> .....	9
6.1 Remote Control Operations.....	9
6.2 Description of Each Control Operation.....	13
<b>Part 7 Installation Manual</b> .....	15
7.1 Choosing an Installation Site.....	15
7.2 Indoor Unit Installation Drawings.....	15
7.3 Installation Tips .....	17
7.4 Indoor unit Installation.....	18
<b>Part 8 Exploded Views and Parts List</b> .....	25
<b>Part 9 Troubleshooting</b> .....	29
9.1 Precautions Before Performing Inspection or Repair.....	29
9.2 Confirmation.....	29
9.3 Flashing LED of Indoor/Outdoor Unit and Primary Judgement.....	29
9.4 How to Check Simply the Main Part.....	30
<b>Part10 Removal Procedure</b> .....	35

---

# Summary and features

**Indoor Unit:**

GEH(09)AA-K3DNA1B/I

GEH(12)AA-K3DNA1B/I

GEH(18)AA-K3DNA1B/I

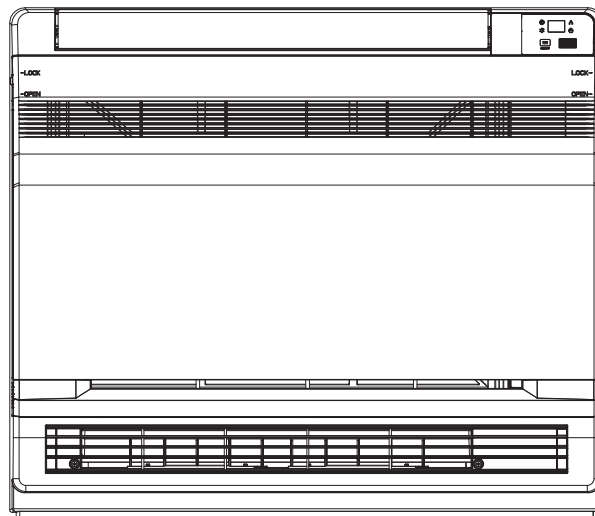

**Remote control**

YAA1FB1

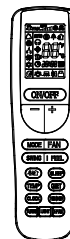

# 1. Safety Precautions

Installing, starting up, and servicing air conditioner can be hazardous due to system pressure, electrical components, and equipment location, etc.

Only trained, qualified installers and service personnel are allowed to install, start-up, and service this equipment. Untrained personnel can perform basic maintenance functions such as cleaning coils. All other operations should be performed by trained service personnel.

When handling the equipment, observe precautions in the manual and on tags, stickers, and labels attached to the equipment. Follow all safety codes. Wear safety glasses and work gloves. Keep quenching cloth and fire extinguisher nearby when brazing.

Read the instructions thoroughly and follow all warnings or cautions in literature and attached to the unit. Consult local building codes and current editions of national as well as local electrical codes.

Recognize the following safety information:



**Warning** Incorrect handling could result in personal injury or death.



**Caution** Incorrect handling may result in minor injury, or damage to product or property.

- Make sure the outdoor unit is installed on a stable, level surface with no accumulation of snow, leaves, or trash beside.
- Make sure the ceiling/wall is strong enough to bear the weight of the unit.
- Make sure the noise of the outdoor unit does not disturb neighbors.
- Follow all the installation instructions to minimize the risk of damage from earthquakes, typhoons or strong winds.
- Avoid contact between refrigerant and fire as it generates poisonous gas.
- Apply specified refrigerant only. Never have it mixed with any other refrigerant. Never have air remain in the refrigerant line as it may lead to rupture and other hazards.
- Make sure no refrigerant gas is leaking out when installation is completed.
- Should there be refrigerant leakage, the density of refrigerant in the air shall in no way exceed its limited value, or it may lead to explosion.
- Keep your fingers and clothing away from any moving parts.
- Clear the site after installation. Make sure no foreign objects are left in the unit.
- Always ensure effective grounding for the unit.



## Warning

All electric work must be performed by a licensed technician according to local regulations and the instructions given in this manual.

- Before installing, modifying, or servicing system, main electrical disconnect switch must be in the OFF position. There may be more than 1 disconnect switch. Lock out and tag switch with a suitable warning label.
- Never supply power to the unit unless all wiring and tubing are completed, reconnected and checked.
- This system adopts highly dangerous electrical voltage. Incorrect connection or inadequate grounding can cause personal injury or death. Stick to the wiring diagram and all the instructions when wiring.
- Have the unit adequately grounded in accordance with local electrical codes.
- Have all wiring connected tightly. Loose connection may lead to overheating and a possible fire hazard.

All installation or repair work shall be performed by your dealer or a specialized subcontractor as there is the risk of fire, electric shock, explosion or injury.



## Caution

- Never install the unit in a place where a combustible gas might leak, or it may lead to fire or explosion.
- Make a proper provision against noise when the unit is installed at a telecommunication center or hospital.
- Provide an electric leak breaker when it is installed in a watery place.
- Never wash the unit with water.
- Handle unit transportation with care. The unit should not be carried by only one person if it is more than 20kg.
- Never touch the heat exchanger fins with bare hands.
- Never touch the compressor or refrigerant piping without wearing glove.
- Do not have the unit operate without air filter.
- Should any emergency occur, stop the unit and disconnect the power immediately.
- Properly insulate any tubing running inside the room to prevent the water from damaging the wall.

## 2.Specifications

### 2.1 Unit Specifications

Item	Console		
	GEH(09)AA-K3DNA1B/I	GEH(12)AA-K3DNA1B/I	GEH(18)AA-K3DNA1B/I
Product Code	CV010N0040	CV010N0050	CV010N0060
Capacity (Cooling) (W)	2600	3500	5300
Capacity (Heating) (W)	2800	3800	5800
Airflow (m <sup>3</sup> /h)	480	550	650
Fan Motor Speed (r/min) (SH/H/HM/M/LM/L/S)	650/560/530/480/430/370/320	750/650/600/550/500/450/350	840/800/720/650/580/530/410
Output of Fan Motor (w)	30	30	30
Fan Motor Capacitor (uF)	/	/	/
Fan Motor RLA(A)	0.14	0.14	0.14
Fan Type-Piece	Centrifugal-1	Centrifugal-1	Centrifugal-1
Diameter-Length (mm)	Φ370X80	Φ370X80	Φ370X80
Evaporator	Aluminum fin-copper tube	Aluminum fin-copper tube	Aluminum fin-copper tube
Pipe Diameter (mm)	Φ7	Φ7	Φ7
Row-Fin Gap(mm)	2-1.2	2-1.2	2-1.2
Coil length (l) x height (H) x coil width (L)	511X396X24	511X396X24	511X396X24
Swing Motor Model	MP24EB	MP24EB	MP24EB
Output of Swing Motor (W)	1.5	1.5	1.5
Fuse (A)	PCB 3.15A	PCB 3.15A	PCB 3.15A
Sound Pressure Level dB (A) (SH/H/M/L/SL)	42/40/36/34/32/31/30	45/42/38/37/35/32/31	50/48/44/43/41/40/39
Sound Power Level dB (A) (SH/H/M/L/SL)	52/50/46/44/42/41/40	55/52/48/47/45/42/41	60/58/54/53/51/50/49
Dimension (W/H/D) ( mm)	700X600X215	700X600X215	700X600X215
Dimension of Package (L/W/H)( mm)	788X695X283	788X695X283	788X695X283
Liquid connections Diameter	Φ6(1/4" )	Φ6(1/4" )	Φ6(1/4" )
Gas connections Diameter	Φ9.52(3/8" )	Φ9.52(3/8" )	Φ12(1/2" )
Net Weight /Gross Weight (kg)	15/18	15/18	15/18

The above data is subject to change without notice. Please refer to the nameplate of the unit.

## 2.2 Noise Criteria Curve Tables for Both Models

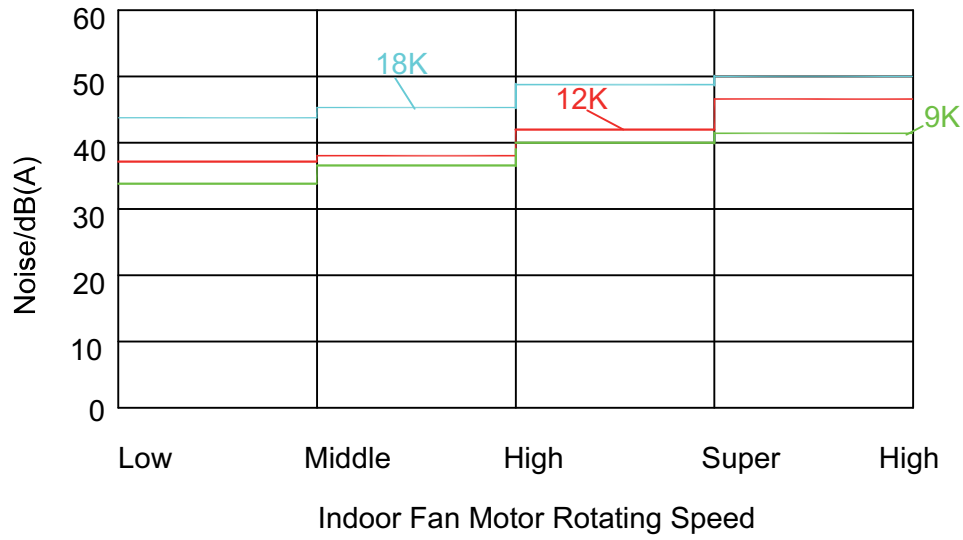

### 3. Construction Views

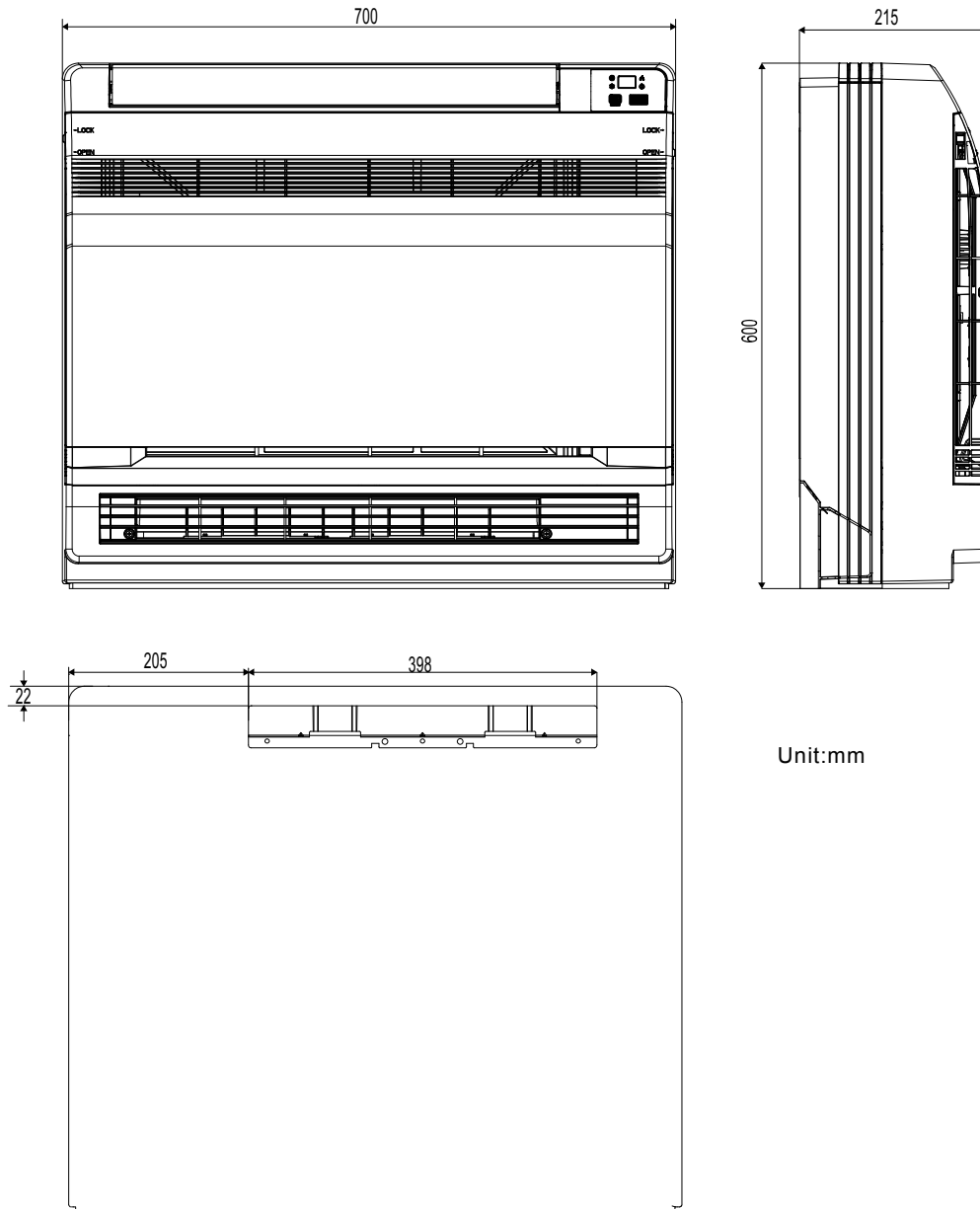

Unit:mm

## 4. Refrigerant System Diagram

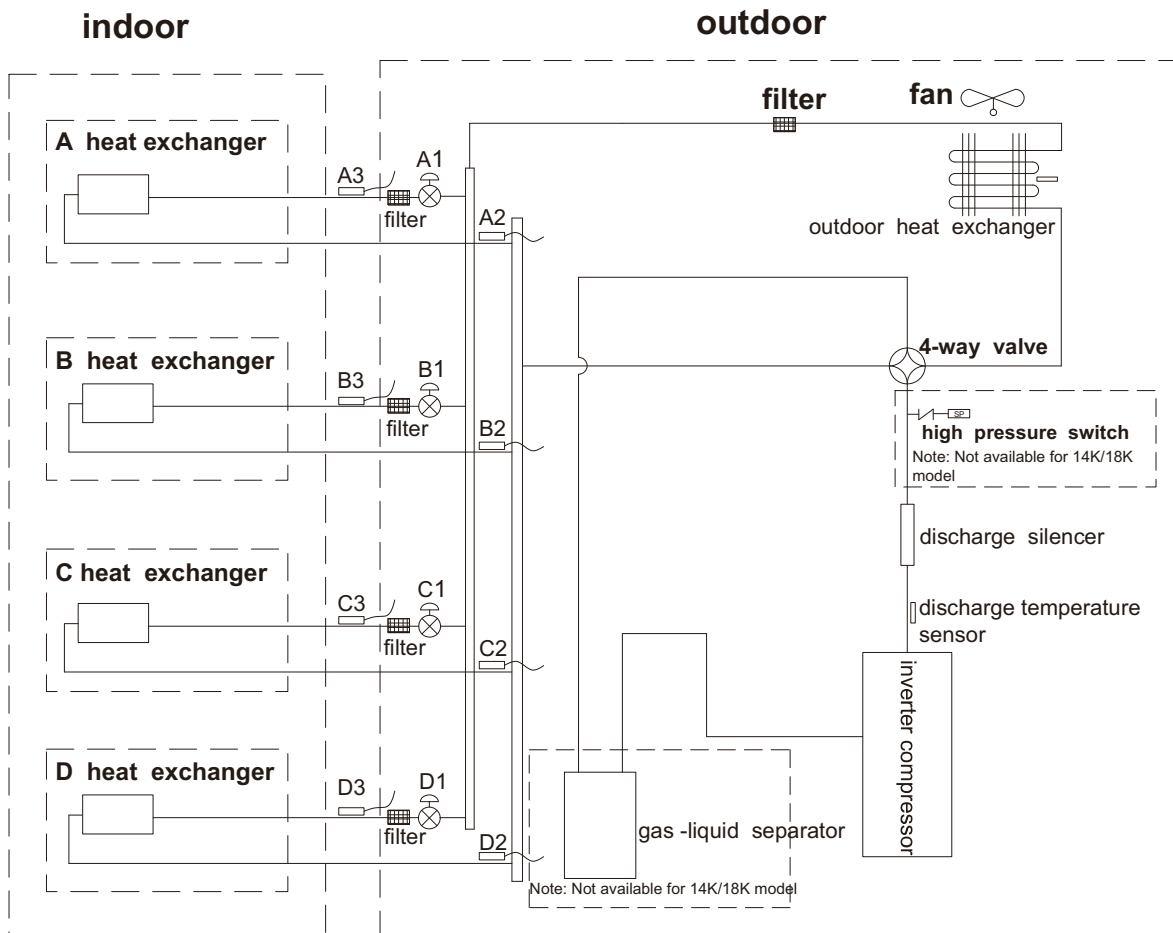

**A1:A-unit electronic expansion valve B1:B-unit electronic expansion valve**  
**C1:C-unit electronic expansion valve D1:D-unit electronic expansion valve**  
**A2:A-unit gas pipe temperature sensor B2:B-unit gas pipe temperature sensor**  
**C2:C-unit gas pipe temperature sensor D2:D-unit gas pipe temperature sensor**  
**A3:A-unit liquid pipe temperature sensor B3:B-unit liquid pipe temperature sensor**  
**C3:C-unit liquid pipe temperature sensor D3:D-unit liquid pipe temperature sensor**



## 5. Schematic Diagram

### 5.1 Electrical Data

Meaning of marks

Symbol	Color symbol	Symbol	Color symbol
WH	WHITE	BN	BROWN
YE	YELLOW	BU	BLUE
RD	RED	BK	BLACK
YEGN	YELLOW GREEN	⊕	PROTECTIVE EARTH

### 5.2 Electrical wiring

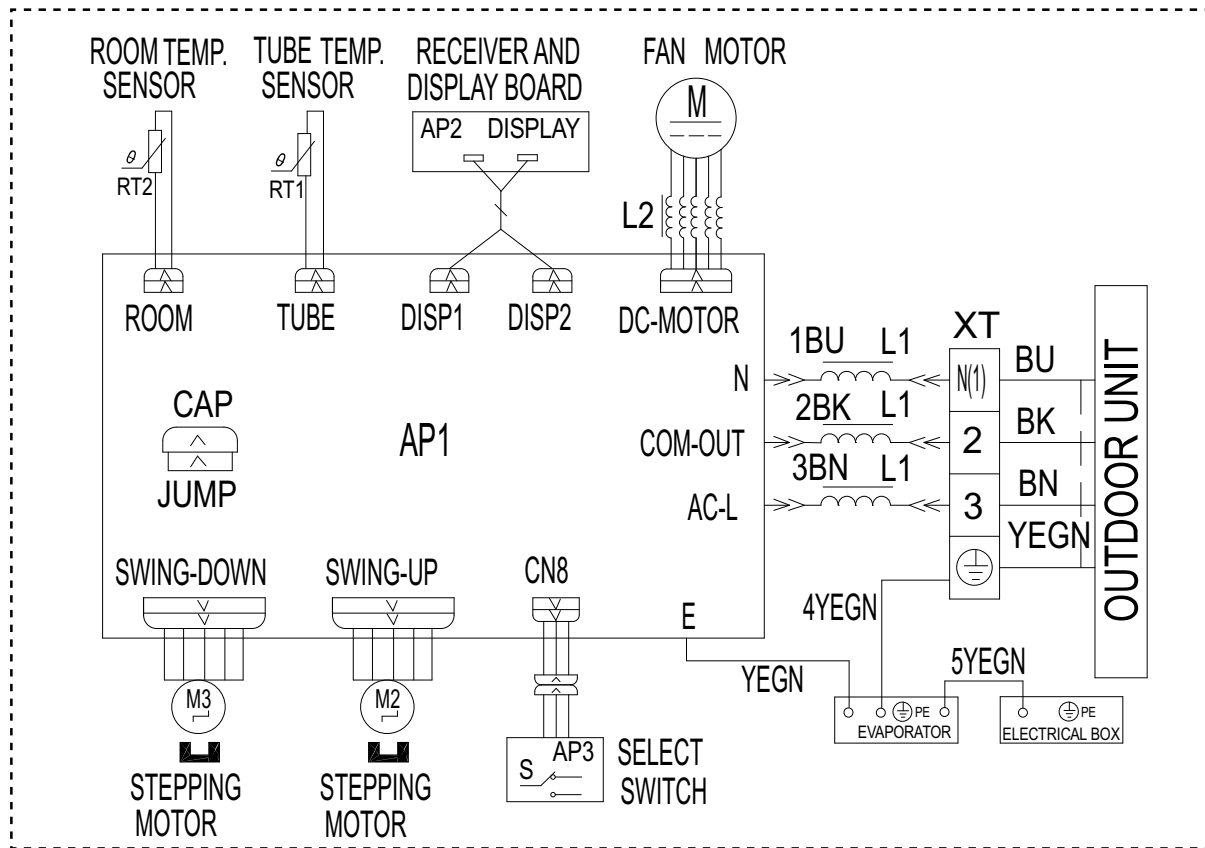

These circuit diagrams are subject to change without notice, please refer to the one supplied with the unit.



## 6. Function and Control

### 6.1 Remote Control Operations



- 1 ON/OFF**  
Press it to start or stop operation.
- 2 -** : Press it to decrease temperature setting.
- 3 +** : Press it to increase temperature setting.
- 4 MODE**  
Press it to select operation mode (AUTO/COOL/DRY/FAN/HEAT).
- 5 FAN**  
Press it to set fan speed.
- 6 SWING**  
Press it set swing angle.
- 7 I FEEL**
- 8 扇/风**  
Press it to set HEALTH or AIR function.
- 9 SLEEP**
- 10 TEMP**
- 11 QUIET**  
Press it to set QUIET function.
- 12 CLOCK**  
Press it set clock.
- 13 T-ON | T-OFF**  
Press it to set auto-off/auto-on timer.
- 14 TURBO**
- 15 LIGHT**  
Press it to turn on/off the light.
- 16 X-FAN**

1 ON/OFF :

Press this button to turn on the unit .Press this button again to turn off the unit.

2 —:

Press this button to decrease set temperature. Holding it down above 2 seconds rapidly decreases set temperature. In AUTO mode, set temperature is not adjustable.

3 + :

Press this button to increase set temperature.Holding it down above 2 seconds rapidly increases set temperature. In AUTO mode, set temperature is not adjustable.

4 MODE :

Each time you press this button,a mode is selected in a sequence that goes from AUTO, COOL,DRY, FAN,and HEAT \*, as the following:

AUTO ► COOL ► DRY ► FAN ► HEAT



\*Note:Only for models with heating function.

After energization, AUTO mode is defaulted. In AUTO mode, the set temperature will not be displayed on the LCD, and the unit will automatically select the suitable operation mode in accordance with the room temperature to make indoor room comfortable.

5 FAN :

This button is used for setting Fan Speed in the sequence that goes from AUTO, , to , then back to Auto.

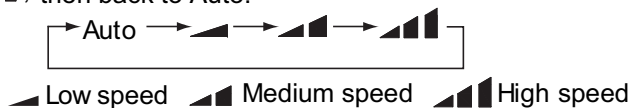

6 SWING:

Press this button to set up &down swing angle, which circularly changes as below



This remote controller is universal . If any command , or is sent out, the unit will carry out the command as

indicates the guide louver swings as:



7 I FEEL:

Press this button to turn on I FEEL function. The unit automatically adjust temperature according to the sensed temperature. Press this button again to cancel I FEEL function.



8 /

Press this button to achieve the on and off of healthy and scavenging functions in operation status.Press this button for the first time to start scavenging function; LCD displays“ Press the button for the second time to start healthy and scavenging functions simultaneously; LCD displays“ ” and “ ”. Press this button for the third time to quit healthy and scavenging functions simultaneously. Press the button for the fourth time to start healthy function; LCD display “ ”. Press this button again to repeat the operation above.





### 9 SLEEP:

- Press this button, can select Sleep 1 ( , Sleep 2 ( , Sleep 3 ( ) and cancel the Sleep, circulate between these, after electrified, Sleep Cancel is defaulted.
- Sleep 1 is Sleep mode 1, in Cool, Dehumidify modes: sleep status after run for one hour, the main unit setting temperature will increase 1 °C, setting temperature increased 2 °C, the unit will run at this setting temperature; In Heat mode: sleep status after run for one hour, the setting temperature will decrease 1 °C, 2 hours, setting temperature will decrease 2 °C, then the unit will run at this setting temperature.
- Sleep 2 is sleep mode 2, that is air conditioner will run according to the presetting a group of sleep temperature curve.
- Sleep 3- the sleep curve setting under Sleep mode by DIY:
  - (1) Under Sleep 3 mode, press "Turbo" button for a long time, remote control enters into user individuation sleep setting status, at this time, the time of remote control will display "1hour ", the setting temperature "88" will display the corresponding temperature of last setting sleep curve and blink (The first entering will display according to the initial curve setting value of original factory);
  - (2) Adjust "+" and "-" button, could change the corresponding setting temperature, after adjusted, press "Turbo "button for confirmation;
  - (3) At this time, 1hour will be automatically increased at the timer position on the remote control, (that are "2hours " or "3hours " or "8hours "), the place of setting temperature "88" will display the corresponding temperature of last setting sleep curve and blink;
  - (4) Repeat the above step (2) ~ (3) operation, until 8hours temperature setting finished, sleep curve setting finished, at this time, the remote control will resume the original timer display; temperature display will resume to original setting temperature.Sleep3- the sleep curve setting under Sleep mode by DIY could be inquired:
- The user could accord to sleep curve setting method to inquire the presetting sleep curve, enter into user individuation sleep setting status, but do not change the temperature, press "Turbo" button directly for confirmation. Note: In the above presetting or enquiry procedure, if continuously within 10s, there is no button pressed, the sleep curve setting within 10s, there is no button pressed, the sleep curve setting status will be automatically quit and resume to display the original displaying. In the presetting or enquiry procedure, press "ON/OFF" button, "Mode" button, "Timer"button or "Sleep" button, the sleep curve setting or enquiry status will quit similarly.



### 10 TEMP:

Pressing TEMP button, , (set temperature), , (indoor ambient temperature) and , (outdoor ambient temperature) and blank is displayed circularly. The unit defaults not to display the icon. During operation of TEMP button, the set temperature is always displayed. Note: Outdoor ambient temperature is only displayed for some models.

### 11 QUIET:

Press this button, the Quiet status is under the Auto Quiet mode (display " ) "signal ) and Quiet mode (display " ) " signal) and Quiet OFF (there is no signal of " ) " displayed), after powered on, the Quiet OFF is defaulted. Note: the Quiet function cannot be set up in Fan and Dry mode; Under the Quiet mode (Display " ) " Under the Quiet mode (Display " ) " signal), the fan speed is not available.

### 12 CLOCK :





Press CLOCK button, blinking . Within 5 seconds, pressing + or - button adjusts the present time. Holding down either button above 2 seconds increases or decreases the time by 1 minute every 0.5 second and then by 10 minutes every 0.5 second. During blinking after setting, press CLOCK button again to confirm the setting, and then  will be constantly displayed.

### 13 T-ON T-OFF:

Press T-ON button to initiate the auto-ON timer. To cancel the auto-timer program, simply press this button again.

After press of this button,  disappears and "ON "blinks .00:00 is displayed for ON time setting. Within 5 seconds, press + or - button to adjust the time value. Every press of either button changes the time setting by 1 minute. Holding down either button rapidly changes the time setting by 1 minute and then 10 minutes. Within 5 Seconds after setting, press TIMER ON button to confirm.

Press T-OFF button to initiate the auto-off timer. To cancel the auto-timer program, simply press the button again. TIMER OFF setting is the same as TIMER ON.

- 14 TURBO:**  
Press this button to activate / deactivate the Turbo function which enables the unit to reach the preset temperature in the shortest time. In COOL mode, the unit will blow strong cooling air at super high fan speed. In HEAT mode, the unit will blow strong heating air at super high fan speed.
- 15 LIGHT:**  
Press LIGHT button to turn on the display's light and press this button again to turn off the display's light. If the light is turned on,  is displayed. If the light is turned off,  disappears.
- 16 X-FAN:**  
Pressing X-FAN button in COOL or DRY mode, the icon  is displayed and the indoor fan will continue operation for 10 minutes in order to dry the indoor unit even though you have turned off the unit.  
After energization, X-FAN OFF is defaulted. X-FAN is not available in AUTO, FAN or HEAT mode.
- 17 Combination of "+" and "-" buttons: About lock**  
Press "+" and "-" buttons simultaneously to lock or unlock the keypad. If the remote controller is locked,  is displayed. In this case, pressing any button,  blinks three times.
- 18 Combination of "MODE" and "-" buttons : About switch between Fahrenheit and centigrade**  
At unit OFF, press "MODE" and "-" buttons simultaneously to switch between °C and °F.
- 19 Combination of "TEMP" and "CLOCK" buttons : About Energy-saving Function**  
Press "TEMP" and "CLOCK" simultaneously in COOL mode to start energy-saving function. Nixie tube on the remote controller displays "SE". Repeat the operation to quit the function.
- 20 Combination of "TEMP" and "CLOCK" buttons : About 8°C Heating Function**  
Press "TEMP" and "CLOCK" simultaneously in HEAT mode to start 8°C Heating Function. Nixie tube on the remote controller displays "8" and a selected temperature of "8°C". (46°F if Fahrenheit is adopted). Repeat the operation to quit the function.
- 21 About Back-lighting Function**  
The unit lights for 4s when energizing for the first time, and 3s for later press.

### Replacement of Batteries

1. Remove the battery cover plate from the rear of the remote controller.  
(As shown in the figure)
2. Take out the old batteries.
3. Insert two new AAA1.5V dry batteries, and pay attention to the polarity.
4. Reinstall the battery cover plate.

#### ★Notes:

- When replacing the batteries, do not use old or different types of batteries, otherwise, it may cause malfunction.
- If the remote controller will not be used for a long time, please remove batteries to prevent batteries from leaking.
- The operation should be performed in its receiving range.
- It should be kept 1m away from the TV set or stereo sound sets.
- If the remote controller does not operate normally, please take the batteries out and reinsert them after 30 seconds. If it still can't operate properly, replace the batteries.

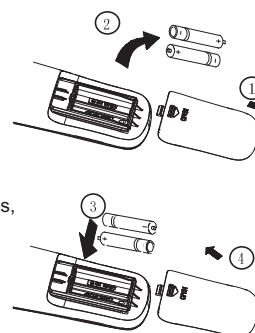

Sketch map for replacing batteries

Notes:

## 6.2 Description of each control operation

### 1. Cooling mode

- (1) Under this mode, the fan and the up swing will operate at setting status. The temperature setting range is 16~30°C.
- (2) The unit is stopped because of malfunction of outdoor unit or protection. The indoor unit keeps original operation status and the error code is displayed.
- (3) Indoor unit is stopped due to mode shock.

### 2. Drying mode

- (1) Under this mode, the fan operates at low speed and the swing operates at setting status. The temperature setting range is 16~30°C.
- (2) The unit is stopped because of malfunction of outdoor unit or protection. The indoor unit keeps original operation status and the error code is displayed.

### 3. Heating mode

(1) Under this mode, the temperature setting range is 16~30°C.

#### (2) Working condition and process for heating

When the unit is turned on under heating mode, the indoor unit turns to cold air prevention status. When the unit is turned off and the indoor unit has been started up before, the indoor unit blows the residual heat.

(3) Protection function: When the compressor is stopped due to malfunction under heating mode, the indoor unit blows the residual heat.

#### (4) Blow residual heat

When the unit stops operation as it reaches the temperature point, indoor unit will continue to run for 60s. The fan speed can't be switched during blowing residual heat period. The upper horizontal louver will turn to the defaulted position in cooling. When the unit operates under heating mode or auto heating mode, compressor will be turned on and the corresponding electric expansion valve is more than 65 and the unit stops operation during the operation status of indoor unit. The upper horizontal louver will turn to the defaulted position in heating mode. The indoor unit operates at low speed for 10s and then the unit stops operation.

#### (5) Defrosting, oil-returning

As it received the signal of defrosting and oil-returning from outdoor unit, the upper horizontal louver will turn to the minimum angle in cooling. 10s later, the indoor fan stop operation. During defrosting and oil-returning process and they are quitted within 5mins, all malfunctions for indoor tube temperature sensor won't be detected.

### 4. Working process for AUTO mode (Mode judgment will be performed every 30s)

Under AUTO mode, standard cooling  $T_{\text{preset}}=25^{\circ}\text{C}$  ( $77^{\circ}\text{F}$ ), standard heating  $T_{\text{preset}}=20^{\circ}\text{C}$  ( $68^{\circ}\text{F}$ ), and standard fan  $T_{\text{preset}}=25^{\circ}\text{C}$  ( $77^{\circ}\text{F}$ ).

- (1) When  $T_{\text{amb}} \geq 26^{\circ}\text{C}$  ( $79^{\circ}\text{F}$ ), the unit operation in cooling mode;
- (2) Heating pump unit: When  $T_{\text{amb}} \leq 19^{\circ}\text{C}$  ( $66^{\circ}\text{F}$ ), the unit operates in heating mode;
- (3) Cooling only unit:  $T_{\text{amb}} \leq 19^{\circ}\text{C}$  ( $66^{\circ}\text{F}$ ), the unit operates in fan mode;
- (4) When  $19^{\circ}\text{C} < T_{\text{indoor amb}} < 26^{\circ}\text{C}$ , if it turns to auto mode as the unit is turned on for the first time the unit will operate at auto fan mode. If it switch to auto mode from other modes, the unit will keep previous operation mode (when it turns to dry mode, the unit operates at auto fan mode).

#### (5) Protection function

Protection function is the same as that in cooling or heating mode.

### 5. Fan mode

Under fan mode, only indoor fan and swing operates. When it operates at auto fan speed, it will operate according to auto fan speed condition in cooling.

### 6. Mode shock

If the mode shock is 1 which is received by indoor unit from outdoor unit, the loads of indoor unit (indoor unit, auxiliary heating, swing) stop operation and the error code is displayed. The mode sent to outdoor unit is still remote control receiving mode. The unit will be turned off during mode shock.

If timer ON is reached, and the mode shock is 1 which is received by indoor unit from outdoor unit, the loads of indoor unit (indoor unit, auxiliary heating, swing) stop operation and the error code is displayed. The mode sent to outdoor unit is still remote control receiving mode.

### 7. Other control

#### 1. Buzzer

Upon energization or availablely operating the unit or remote controller, the buzzer will give out a beep.

#### 2. Auto button

If this button is pressed, the unit will operate in AUTO mode and indoor fan will operate at auto speed; meanwhile, the swing motor

operates. Press this button again to turn off the unit.

### 3. 8 °C heating function

Under heating mode, press TEMP+CLOCK buttons simultaneously. Under this mode, "cold air prevention protection" will be shielded.

### 4. I FEEL function

When I FEEL command is received, the controller will operate according to the ambient temperature sent by the remote controller (For defrosting and cold blow prevention, the unit operates according to the ambient temperature sensed by the air conditioner). The remote controller will send ambient temperature data to the controller every 10min. When the data has not been received after 11mins, the unit will operate according to the temperature sensed by the air conditioner. If I FEEL function is not selected, the ambient temperature will be that sensed by the air conditioner. I FEEL function will not to be memorized.

### 5. Timer function

General timer and clock timer functions are compatible by equipping remote controller with different functions.

#### General Timer

**Timer ON** can be set at unit OFF. If selected ON time is reached, the unit will start to operate according to previous setting status. Time setting range is 0.5-24hr in 30-minute increments.

**Timer OFF** can be set at unit ON. If selected OFF time is reached, the unit will stop operation. Time setting range is 0.5-24hr in 30-minute increments.

### 6. Sleep function

This mode is only valid in cooling and heating modes. The unit will select proper sleep curve to operate according to different set temperature.

### 7. Switchover function for defrosting mode

If H1 isn't displayed on remote controller under OFF status, the unit will turn to "defrosting mode 1" after the unit is turn on by remote controller. After indoor unit receives remote control signal, it will send "defrosting mode 1" to outdoor unit. If H2 is displayed on remote controller under OFF status, the unit will turn to "defrosting mode 2" after the unit is turn on by remote controller. After indoor unit receives remote control signal, it will send "defrosting mode 2" to outdoor unit.

Under OFF status, press MODE and AUXILIARY button simultaneously on remote controller to switch "defrosting mode 1" and "defrosting mode 2".

### 8. Compulsory defrosting function

When the unit is turned on in heating by remote controller and the set temperature is 16°C, press "+,-,+,-,+,-" continuously within 5s, the indoor unit turns to compulsory defrosting setting and it will send compulsory defrosting mode to outdoor unit.

When indoor unit received the compulsory defrosting signal from outdoor unit, the indoor unit will quit from the compulsory defrosting setting and it will cancel to send compulsory defrosting mode to outdoor unit.

### 9. Refrigerant recovery function

Turn to Freon recovery mode: After the unit is energized for 5min, and the unit is turned on at 16°C under cooling mode, press light button on remote controller for 3 times successively within 3s to turn to Freon recovery mode. Fo is displayed and it will send Freon recovery mode to outdoor unit.

Quit from Freon recovery mode: After it turns to Freon mode, if it receives any signal from remote controller or it turns to Freon recovery mode for 25 mins, it will quit from Freon recovery mode.

Turn to the action for Freon recovery mode: indoor unit will be turned on in cooling mode. The fan speed is super-high fan speed and the set temperature is 16°C. The horizontal louver will turn to the minimum operation angle.

Quit the action for Freon recovery mode: The indoor fan operates at the previous set status by remote controller.

### 10. Pilot run function

When the set temperature is 30°C under cooling mode, press "+,-,+,-,+,-" continuously within 3s, the indoor unit turns to pilot run setting mode and it will send pilot run mode to outdoor unit.

Pilot run mode: it operates under cooling mode and "dd" is displayed.

Quit the pilot run mode and indoor unit cancels "dd" display. If it receives "wrong wire connection of malfunction of expansion valve" from outdoor unit, "dn" will be displayed.



## 7. Installation Manual

### 7.1 Choosing an Installation Site

Before choosing the installation site, obtain user approval.

#### Indoor unit

The indoor unit should be sited in a place where:

- 1) the restrictions on installation specified in the indoor unit installation drawings are met.
- 2) both air intake and exhaust have clear paths met.
- 3) the unit is not in the path of direct sunlight.
- 4) the unit is away from the source of heat or steam.
- 5) there is no source of machine oil vapour (this may shorten indoor unit life).
- 6) cool(warm) air is circulated throughout the room.
- 7) the unit is away from electronic ignition type fluorescent lamps (inverter or rapid start type) as they may shorten the remote controller range.
- 8) the unit is at least 1 metre away from any television or radio set (unit may cause interference with the picture or sound).

### 7.2 Indoor Unit Installation Drawings

The indoor unit may be mounted in any of the three styles shown here.

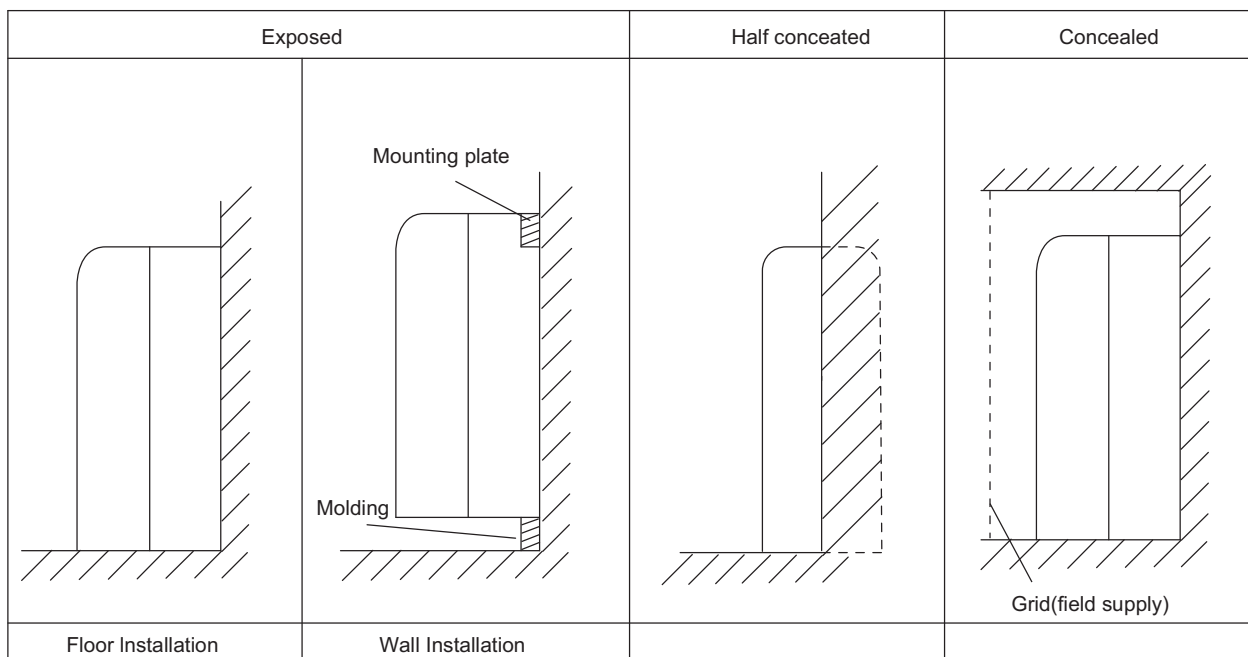

Location for securing the installation panel.

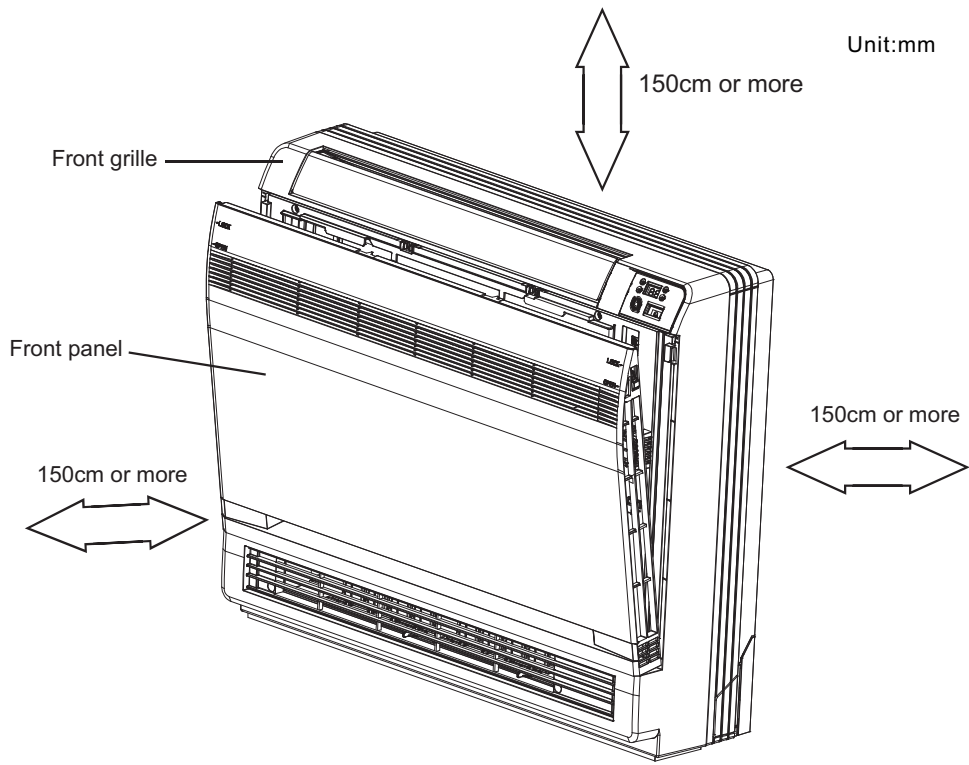
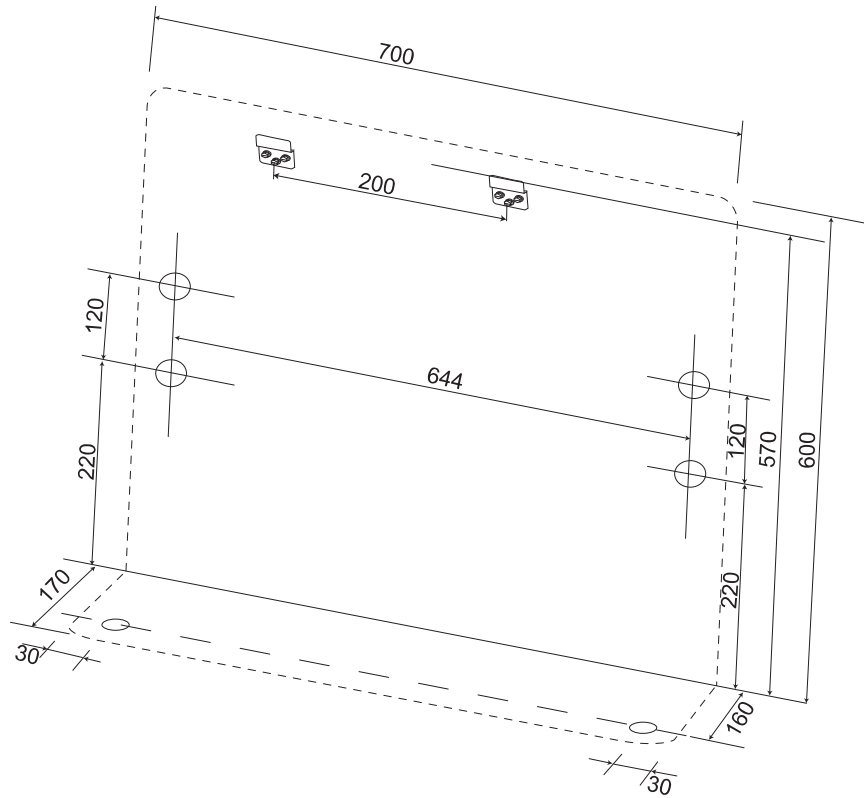

## 7.3 Installation Tips

### 1.Removing and installing front pane

● Removal method

- 1)Slide until the 2 stoppers click into place
- 2)Open the front panel forward and undo the string
- 3)Remove the front panel

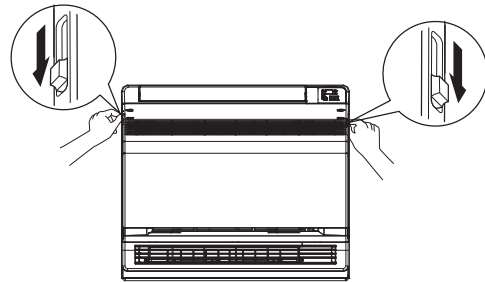

● Installation method

- 1)Attach the front grille and front panel after pulling the string around them.
- 2)Close the front panel and slide until the stoppers click outside.

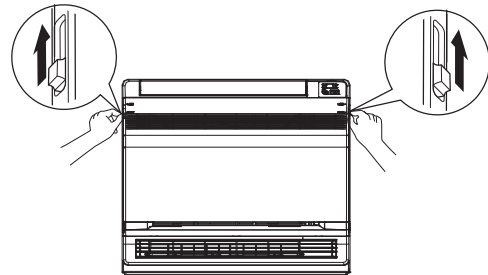

### 2.Removing and installing front grille

● Removal method

- 1).Open the front panel.
- 2)Remove the 4 screws and remove the front grille while pulling it forward(3 tabs).

● Installation method

- 1)Secure the front grille with the 4 installation screws (3 tabs)
- 2)Return the front panel to the original position.

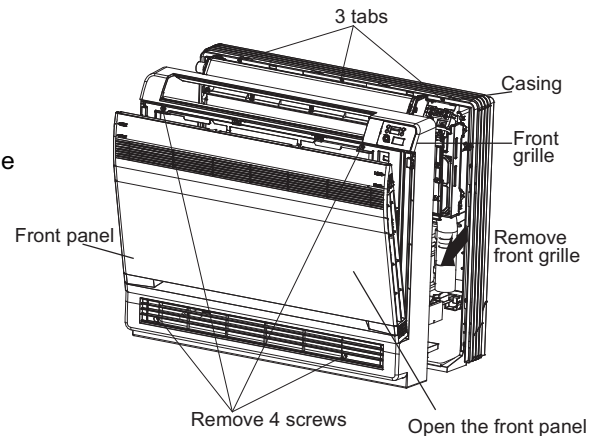

### 3.How to set the different addresses

When two indoor units are installed in one room, the two wireless remote controllers can be set for different addresses.

- 1)Remove the front grille.
- 2)Live the sensor securing plate and remove the front metal plate cover.
- 3)Remove the electric box(1 screw).
- 4)Remove the thermistor.
- 5)Remove the side metal plate cover(7 tabs).
- 6)Cut the address jumper(JA )on the printed circuit board.

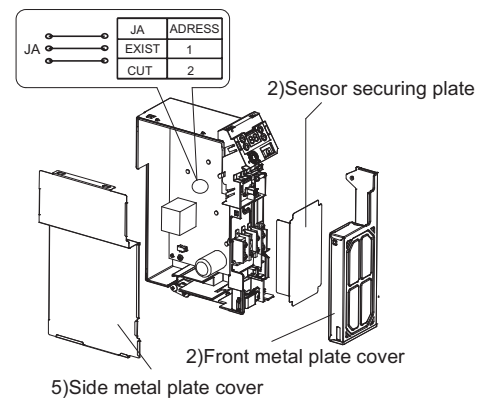
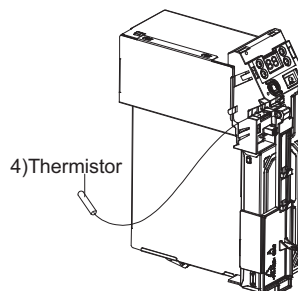
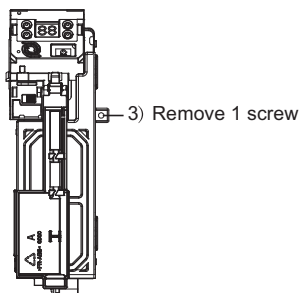

## 7.4 Indoor unit Installation

### 1.Refrigerant piping

- 1)Drill a hole ( 65mm in diameter ) in the spot indicated by the  symbol in the illustration ad below .
- 2)The location of the hole is different depending on which side of the pipe is taken out .
- 3)For piping ,see**6.Connecting the refrigerant pipe** ,under Indoor Unit Installation(1).
- 4)Allow space around the pipe for a easier indoor unit pipe connection.

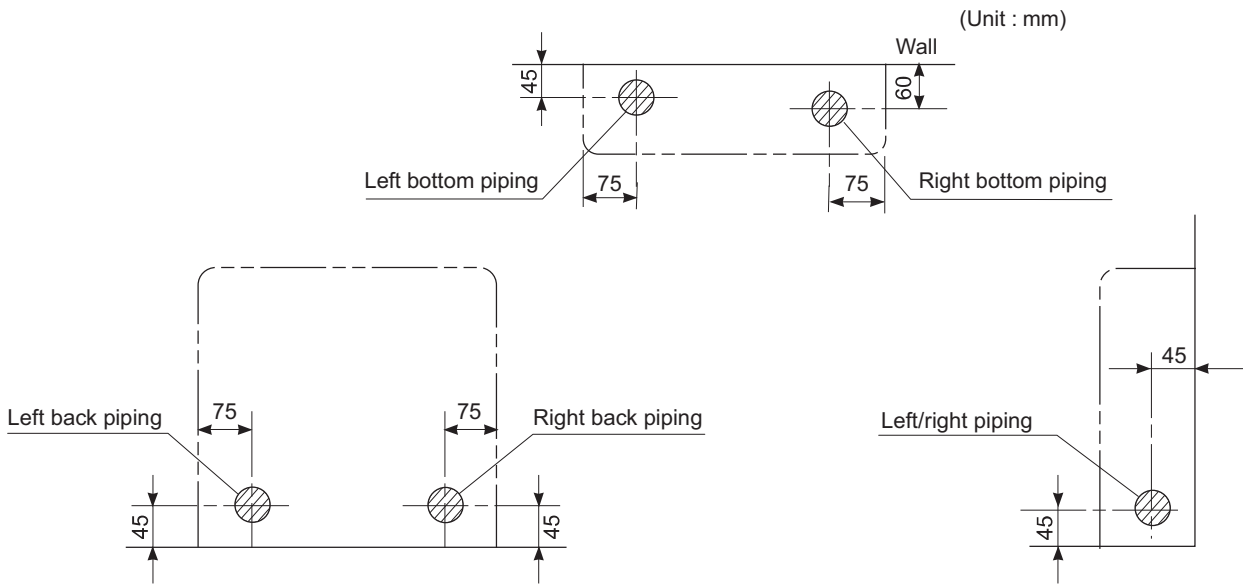

### CAUTION

Min.allowable length

- The suggested shortest pipe length is 2.5m,in order to avoid noise from the outdoor unit and vibration.  
(Mechanical noise and vibration may occur depending on how the unit is installed and the environment in which it is used.)
- See the installation manual for the outdoor unit for the maximum pipe length.
- For multi-connections ,see the installation manual for the multi-outdoor unit.

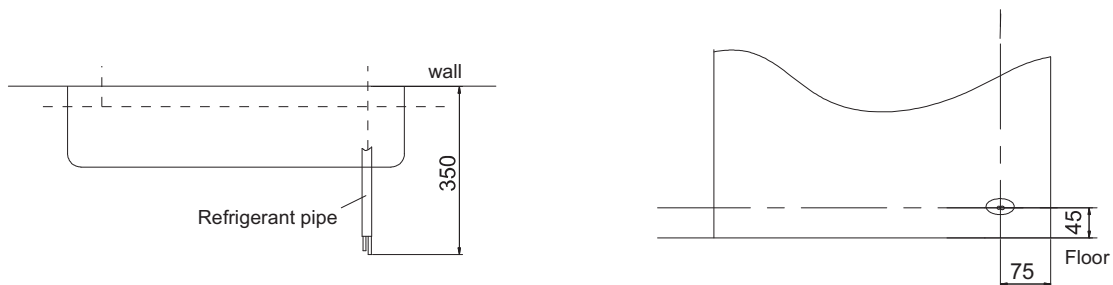

## 2. Boring a wall hole and installing wall embedded pipe

- For walls containing metal frame or metal board ,be sure to use a wall embedded pipe and wall cover in the feed-through hole to
- Be sure to caulk the gaps around the pipes with caulking material to prevent water leakage.

- 1)Bore a feed-through hole of 65mm in the wall so it has a down slope toward the outside.
- 2)Insert a wall pipe into the hole.
- 3)Insert a wall cover into wall pipe .
- 4)After completing refrigerant piping, wiring, and drain piping, caulk pipe hole gap with putty.

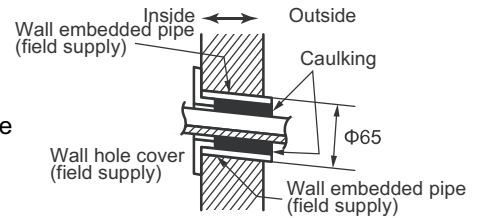

## 3. Drain piping

- 1)Use commercial rigid polyvinyl chloride pipe (general VP 20 pipe, outer diameter 26mm, inner diameter 20mm) for the drain pipe.
- 2)The drain hose (outer diameter 18mm at connecting end, 220mm long)is supplied with the indoor unit. Prepare the drain pipe picture below position.
- 3)The drain pipe should be inclined downward so that water will flow smoothly without any accumulation.(Should not be trap.)
- 4)Insert the drain hose to this depth so it won't be pulled out of the drain pipe.
- 5)Insulate the indoor drain pipe with 10mm or more of insulation material to prevent condensation.
- 6)Remove the air filters and pour some water into the drain pan to check the water flows smoothly.

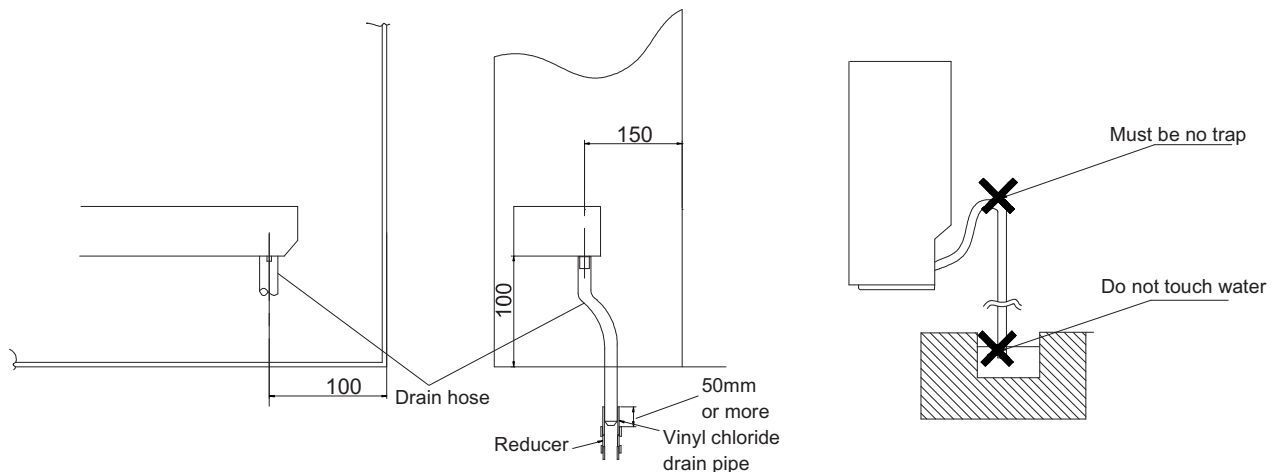

### CAUTION

Use polyvinyl chloride adhesive agent for gluing. Failure to do so may cause water leakage.

## 4. Installing indoor unit

### 4-1.Preparation

- Open the front panel, remove the 4 screws and dismount the front grille while pulling it forward.
- Follow the arrows to disengage the clasps on the front case to remove it.
- Follow the procedure below when removing the slit portions.

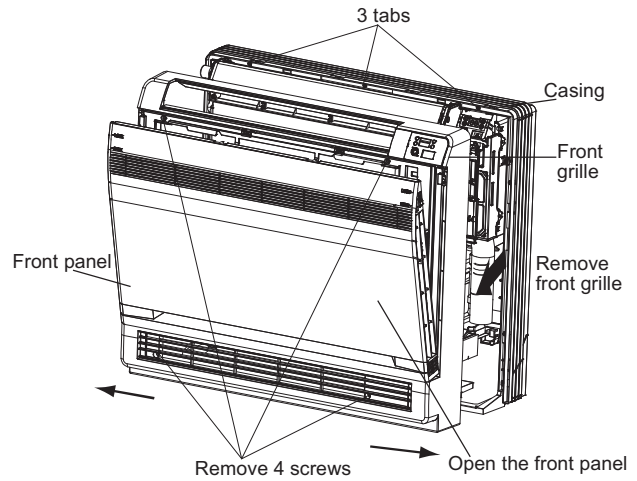

#### ■ For Moldings

- Remove the pillars. (Remove the slit portions on the bottom frame using nippers.)

#### ■ For Side Piping

- Remove the pillars.
  - 1)Remove the 7screws.
  - 2)Remove the upper casing (2 tabs).
  - 3)Remove the left and right casings (2 tabs on each side ).
  - 4)Remove the slit portions on the bottom frame and casings using nippers .
  - 5)Return by following the steps in reverse order(3>2>1).

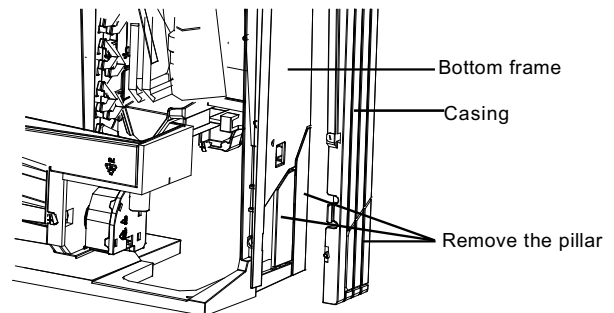
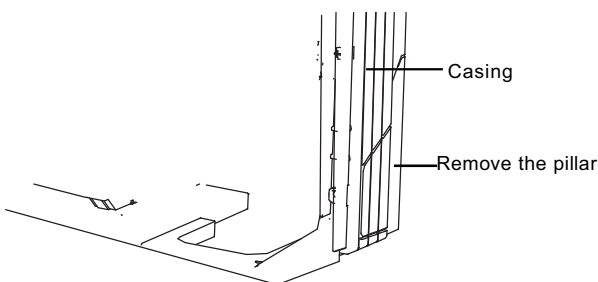
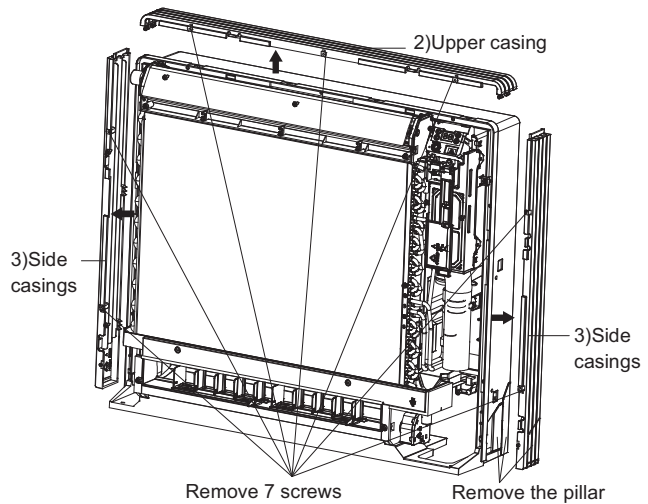

### 4-2.Installation

- Secure using 6 screws for floor installations.(Do not forget to secure to the rear wall.)
- For wall installations, secure the mounting plate using 5 screws and the indoor unit using 4 screws.

The mounting plate should be installed on a wall which can support the weight of the indoor unit.

- 1) Temporarily secure the mounting plate to the wall, make sure that the panel is completely level, and mark the boring points on the wall.
- 2) Secure the mounting plate to the wall with screws.

Floor Installation

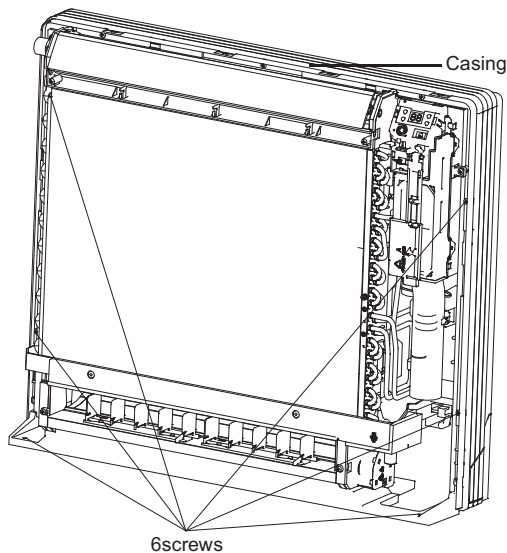

Wall Installation

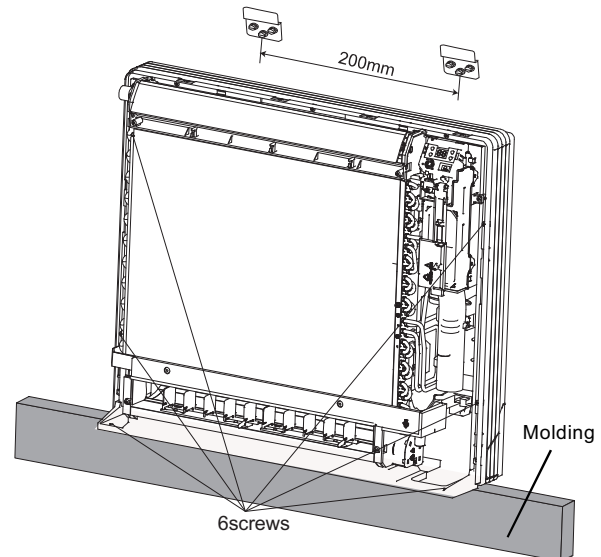

- 3) Once refrigerant piping and drain piping connections are complete, fill in the gap of the through hole with putty. A gap can lead to condensation on the refrigerant pipe, and drain pipe, and the entry of insects into the pipes.
- 4) Attach the front panel and front grille in their original positions once all connections are complete.

### 5. Flaring the pipe end

- 1) Cut the pipe end with a pipe cutter.
- 2) Remove burrs with the cut surface facing downward so that the chips do not enter the pipe.
- 3) Fit the flare nut on the pipe.
- 4) Flare the pipe.
- 5) Check that the flaring is properly made.

#### ⚠ WARNING

- 1) DO not use mineral oil on flared part.
- 2) Prevent mineral oil from getting into the system as this would reduce the lifetime of the units.
- 3) Never use piping which had been used for previous installations. Only use parts which are delivered with the unit.
- 4) Do never install a drier to this R410A unit in order to guarantee its lifetime.
- 5) The drying material may dissolve and damage the system.
- 6) Incomplete flaring may cause refrigerant gas leakage.

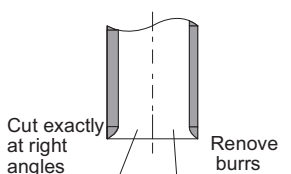

Flaring  
Set exactly at the position shown below

Flare tool for R410A	Conventional flare tool	
	Clutch-type	Wing-nut type (Imperial-type)
A	0-0.5mm	1.0-1.5mm
		1.5-2.0mm

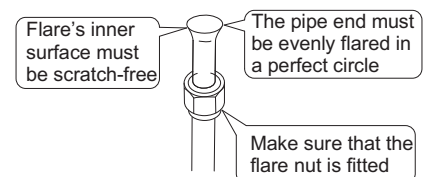

## 6. Connecting the refrigerant pipe

1) Use torque wrenches when tightening the flare nuts to prevent damage to the flare nuts and gas leaks.



2) Align the centres of both flares and tighten the flares and tighten the flare nuts 3 or 4 turns by hand.

Then tighten them fully with the torque wrenches.

3) To prevent gas leakage, apply refrigeration oil on both inner and outer surfaces in the flare. (Use refrigeration oil for R410A.)

Flare nut tightening torque		
Gas side		Liquid side
25/35 class	50 class	25/35/50 class
3/8 inch	1/2 inch	1/4 inch
32.7-39.9 N.m (333-407kgf.cm)	49.5-60.3 N.m (505-615kgf.cm)	14.2-17.2 N.m (144-175kgf.cm)

### 6-1. Caution on piping handling

- 1) Protect the open end of the pipe against dust and moisture.
- 2) All pipe bends should be as gentle as possible. Use a pipe bender for bending.  
(Bending radius should be 30 to 40mm or larger.)

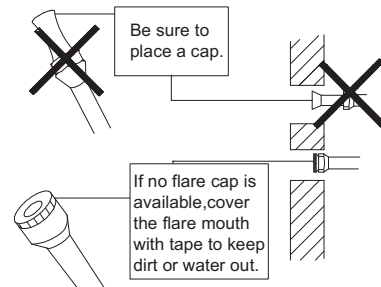

### 6-2. Selection of copper and heat insulation materials

● When using commercial copper pipes and fittings, observe the following:

- 1) Insulation material: Polyethylene foam  
Heat transfer rate: 0.041 to 0.052W/mK (0.035 to 0.045kcal/(mh°C))  
Refrigerant gas pipe's surface temperature reaches 110°C max.  
Choose heat insulation materials that will withstand this temperature.

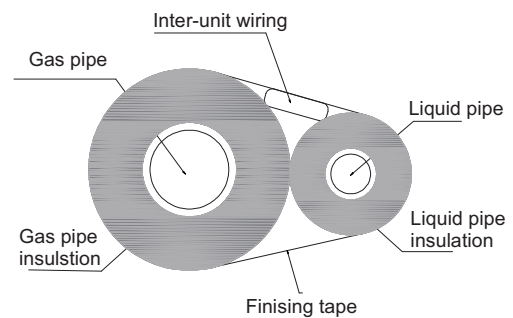

2) Be sure to insulate both the gas and liquid piping and to provide insulation dimensions as below.

Gas side		Liquid side	Gas pipe thermal insulation		Liquid pipe thermal insulation
25/35 class	50class		25/35 class	50class	
O.D. 9.55mm	O.D. 12.7mm	O.D. 6.4mm	I.D. 12-15mm	I.D. 14-16mm	I.D. 8-10mm
Thickness 0.8mm			Thickness 10mm Min.		

3) Use separate thermal insulation pipes for gas and liquid refrigerant pipes.



## 7. Checking for gas leakage

- 1) Check for leakage of gas after air purging
- 2) See the sections on air purges and gas leak checks in the installation manual for the outdoor unit.

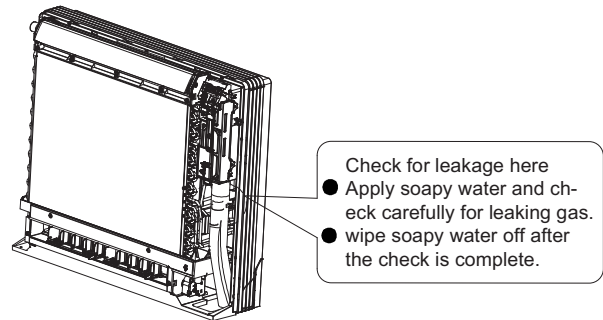

## 8. Attaching the connection pipe

- Attach the pipe after checking for gas leakage, described above.
- 1) Cut the insulated portion of the on-site piping, matching it up with the connecting portion.
  - 2) Secure the slit on the refrigerant piping side with the butt joint on the auxiliary piping using the tape, making sure there are no gaps.
  - 3) Wrap the slit and butt joint with the included insulation sheet, making sure there are no gaps.

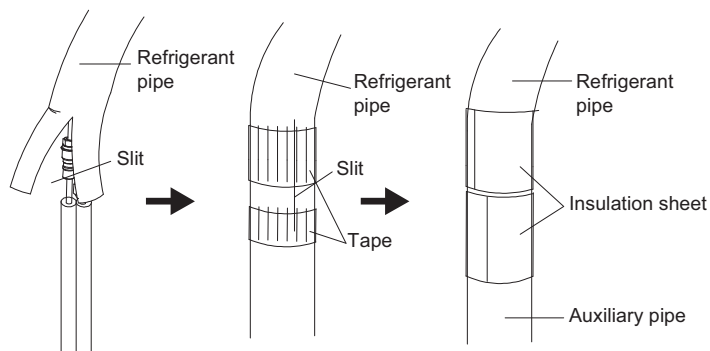

### ⚠ CAUTION

- 1) Insulate the joint of the pipes securely. Incomplete insulation may lead to water leakage.
- 2) Push the pipe inside so it does not place undue force on the front grille.

## 9. Connecting the drain hose

Insert the supplied C drain hose into the socket of the drain pan.  
Fully insert the drain hose until it adheres to a seat of the socket.

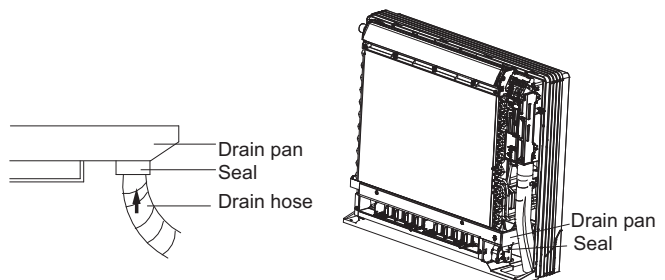

## 10. Wiring

With a Multi indoor unit, install as described in the installation manual supplied with the Multi outdoor unit.

● Live the sensor securing plate, remove the front metal plate cover, and connect the branch wiring to the terminal block.

- 1) Strip wire ends (15mm)
- 2) Match wire colours with terminal numbers on indoor and outdoor unit's terminal blocks and firmly screw wires to the corresponding terminals.
- 3) Connect the earth wires to the corresponding terminals.
- 4) Pull wires to make sure that they are securely latched up, then retain wires with wire retainer.
- 5) In case of connecting to an adapter system, Run the remote controller cable and attach the S21. (Refer to 11. When connecting go an system.)

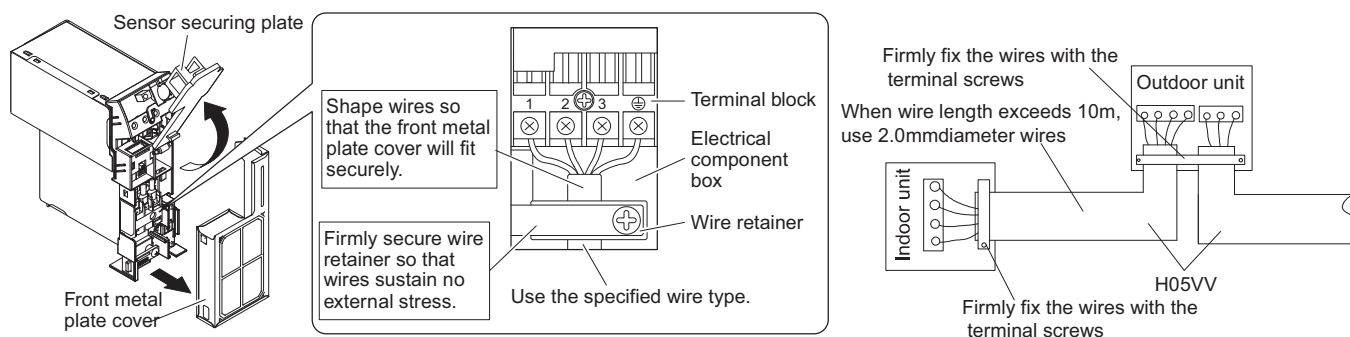

### ⚠ CAUTION

- 1) Do not use tapped wires, stranded wires, extension cords, or starburst connections, as they may cause overheating, electrical shock, or fire.
- 2) Do not use locally purchased electrical parts inside the product. (Do not branch the power for the drain pump, etc, from the terminal block.) Doing so may cause electric shock or fire.)

## 8 . Exploded Views and Parts List

Models GEH(09)AA-K3DNA1B/I GEH(12)AA-K3DNA1B/I

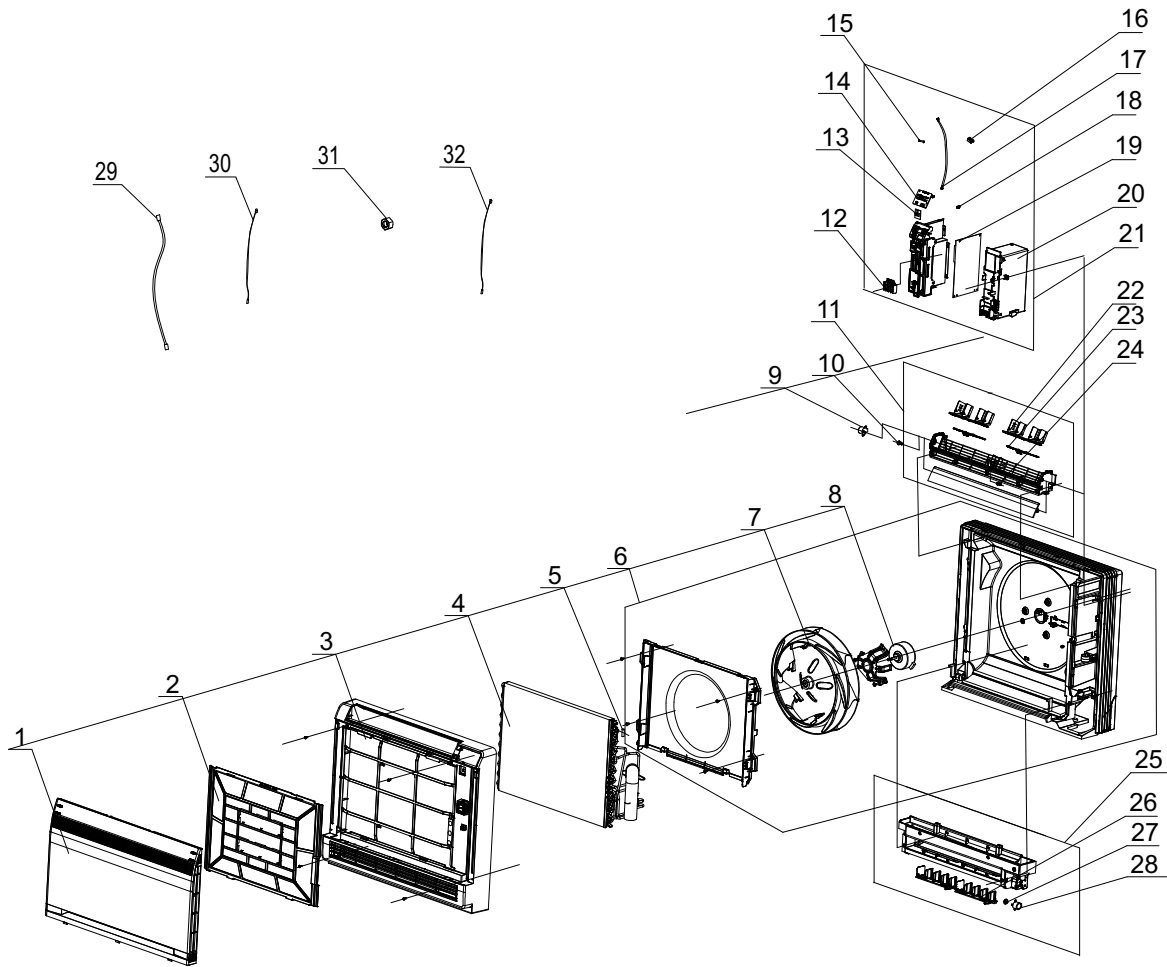

NO.	Description	Part Code		Qty
		GEH(09)AA-K3DNA1B/I	GEH(12)AA-K3DNA1B/I	
		Product Code	CV010N0040	
1	Front Panel Assy	20012756	20012756	1
2	Filter Sub-Assy	11122119	11122119	1
3	Front Case Assy	20012601	20012601	1
4	Evaporator Assy	01002626	01002626	1
5	Temp. Sensor sleeving	05212423	05212423	1
6	Rear Case assy	22202462	22202462	1
7	Centrifugal fan	10312005	10312005	1
8	Fan Motor	15012123	15012123	1
9	Step Motor	1521210805	1521210805	1
10	Crank	73012005	73012005	1
11	Swing Assy	10102042	10102042	1
12	Terminal Board	42011233	42011233	1
13	Switch Board	30112007	30112007	1
14	Display Board	30568131	30568131	1
15	Fuse	46010055	46010055	1
16	Radiator	49010252	49010252	1
17	Signal Wire	4003004202	4003004202	1
18	Jumper	4202300101	4202300101	1
19	Main Board	30138613	30138613	1
20	Electric Box	20112116	20112116	1
21	Electric Box Assy	2020262201	2020262201	1
22	Air Louver (upper)	10512143	10512143	1
23	Swing lever	10582096	10582096	2
24	Shaft of guide louver	10542020	10542020	2
25	Water Tray Assy	20182141	20182141	1
26	Air Louver (lower)	10512144	10512144	2
27	Axis (lower step motor)	10542034	10542034	1
28	Step Motor	1521210101	1521210101	1
29	Connecting Cable	400204056	400204056	0
30	Tube Sensor	390000591	390000591	1
31	Pipe Connection Nut accessories	06320020	06320020	1
32	Ambient Temperature Sensor	390000453	390000453	1
33	Remote Controller	30510134	30510134	1

The data above are subject to change without notice.

Model GEH(18)AA-K3DNA1B/I

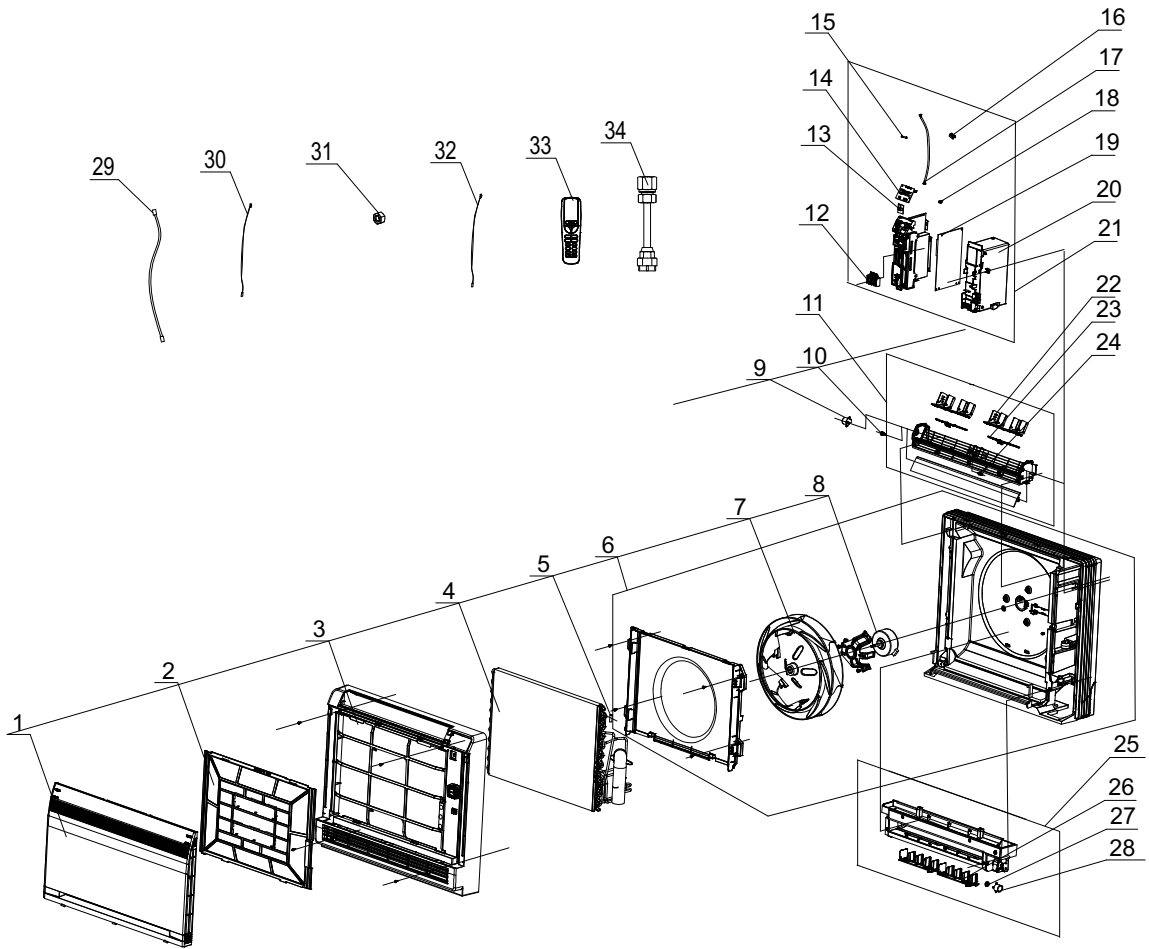

NO.	Description	Part Code	Qty
		GEH(18)AA-K3DNA1B/I	
		Product Code CV010N0060	
1	Front Panel Assy	20012756	1
2	Filter Sub-Assy	11122119	1
3	Front Case Assy	20012601	1
4	Evaporator Assy	01002608	1
5	Temp. Sensor sleeving	05212423	1
6	Rear Case assy	22202462	1
7	Centrifugal fan	10312005	1
8	Fan Motor	15012123	1
9	Step Motor	1521210805	1
10	Crank	73012005	1
11	Swing Assy	10102042	1
12	Terminal Board	42011233	1
13	Switch Board	30112007	1
14	Display Board	30568131	1
15	Fuse	46010055	1
16	Radiator	49010252	1
17	Signal Wire	4003004202	1
18	Jumper	4202300103	1
19	Main Board	30138613	1
20	Electric Box	20112116	1
21	Electric Box Assy	2020242301	1
22	Air Louver (upper)	10512143	2
23	Swing lever	10582096	2
24	Shaft of guide louver	10542020	1
25	Water Tray Assy	20182141	1
26	Air Louver (lower)	10512144	2
27	Axis (lower step motor)	10542034	1
28	Step Motor	1521210101	1
29	Connecting Cable	400204056	0
30	Tube Sensor	390000591	1
31	Pipe Connection Nut accessories	06320020	1
32	Ambient Temperature Sensor	390000453	1
33	Remote Controller	30510134	1
34	Tube connector sub-assy	06643008	1

The data above are subject to change without notice.

## 9. Troubleshooting

### 9.1 Precautions before Performing Inspection or Repair

Be cautious during installation and maintenance. Do operation following the regulations to avoid electric shock and casualty or even death due to drop from high altitude.

\* Static maintenance is the maintenance during de-energization of the air conditioner. For static maintenance, make sure that the unit is de-energized and the plug is disconnected.

\* Dynamic maintenance is the maintenance during energization of the unit. Before dynamic maintenance, check the electricity and ensure that there is ground wire on the site. Check if there is electricity on the housing and connection copper pipe of the air conditioner with voltage tester. After ensure insulation place and the safety, the maintenance can be performed.

Take sufficient care to avoid directly touching any of the circuit parts without first turning off the power.

At times such as when the circuit board is to be replaced, place the circuit board assembly in a vertical position.

Normally, diagnose troubles according to the trouble diagnosis procedure as described below. (Refer to the check points in servicing written on the wiring diagrams attached to the indoor/outdoor units.)

No.	Troubleshooting procedure
1	Confirmation
2	Judgement by Flashing LED of Indoor/Outdoor Unit
3	How to Check simply the main part

### 9.2 Confirmation

#### (1) Confirmation of Power Supply

Confirm that the power breaker operates(ON) normally;

#### (2) Confirmation of Power Voltage

Confirm that power voltage is AC 220-230-240 10%. If power voltage is not in this range, the unit may not operate normally.

### 9.3 Flashing LED of Indoor/Outdoor Unit and Primary Judgement

Malfunction, status display table					
Malfunction name	Malfunction type	Dual-8	Display of indicator		
			Operation indicator	Cooling indicator	Heating indicator
Communication malfunction	Hardware malfunction	E6	Blink 6 times		
Malfunction protection of jumper cap	Hardware malfunction	C5	Blink 15 times		
Without feedback of indoor unit's motor	Hardware malfunction	H6	Blink 11 times	Blink once	
Indoor ambient temperature sensor is open/short-circuited	Hardware malfunction	F1		Blink twice	
Indoor evaporator sensor is open/short-circuited	Hardware malfunction	F2			

## 9.4 How to Check simply the main part

(1) Troubleshooting for malfunction of temperature sensor  
main check point:

- Whether the temperature sensor is broken or damaged;
- Whether the temperature sensor terminal is loosened or not connected;
- Whether the mainboard is damaged;

Check flow chart:

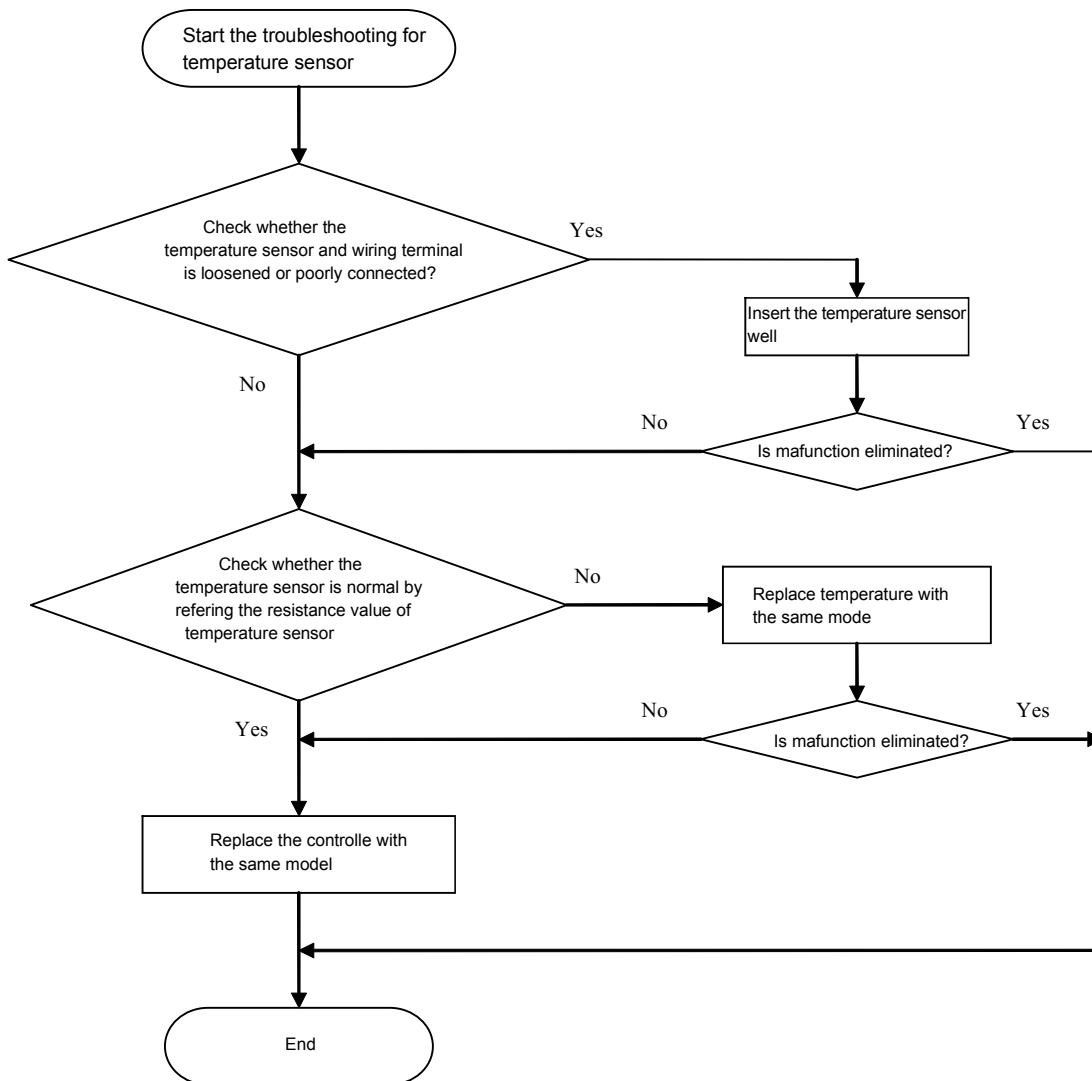



(2) Troubleshooting for communication malfunction

Main check point:

- Check whether the connection wire for indoor and outdoor units and the wires inside the indoor unit is connected well;
- Check whether the mainboards of indoor unit or outdoor unit are damaged;

Check flow chart:

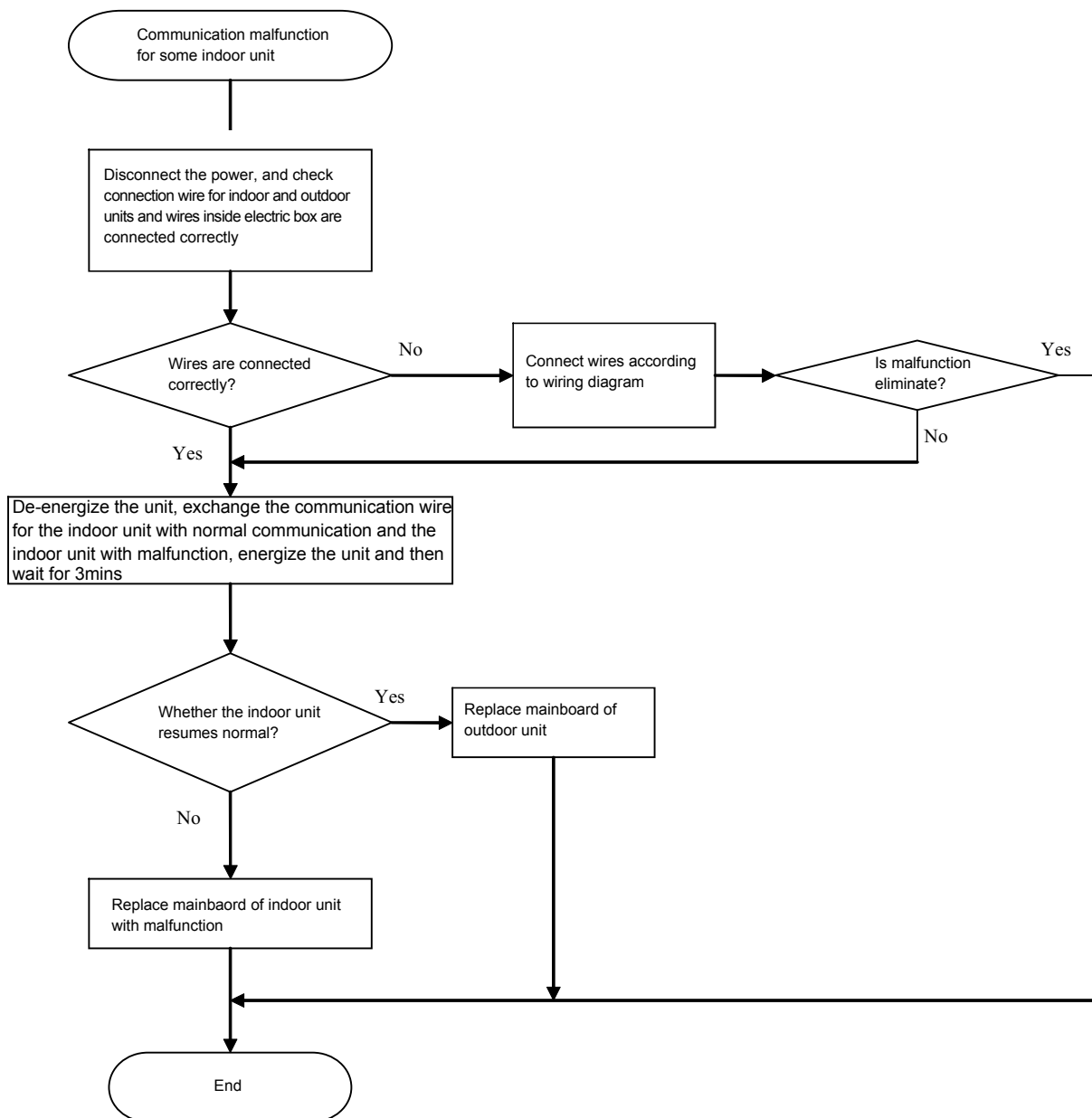

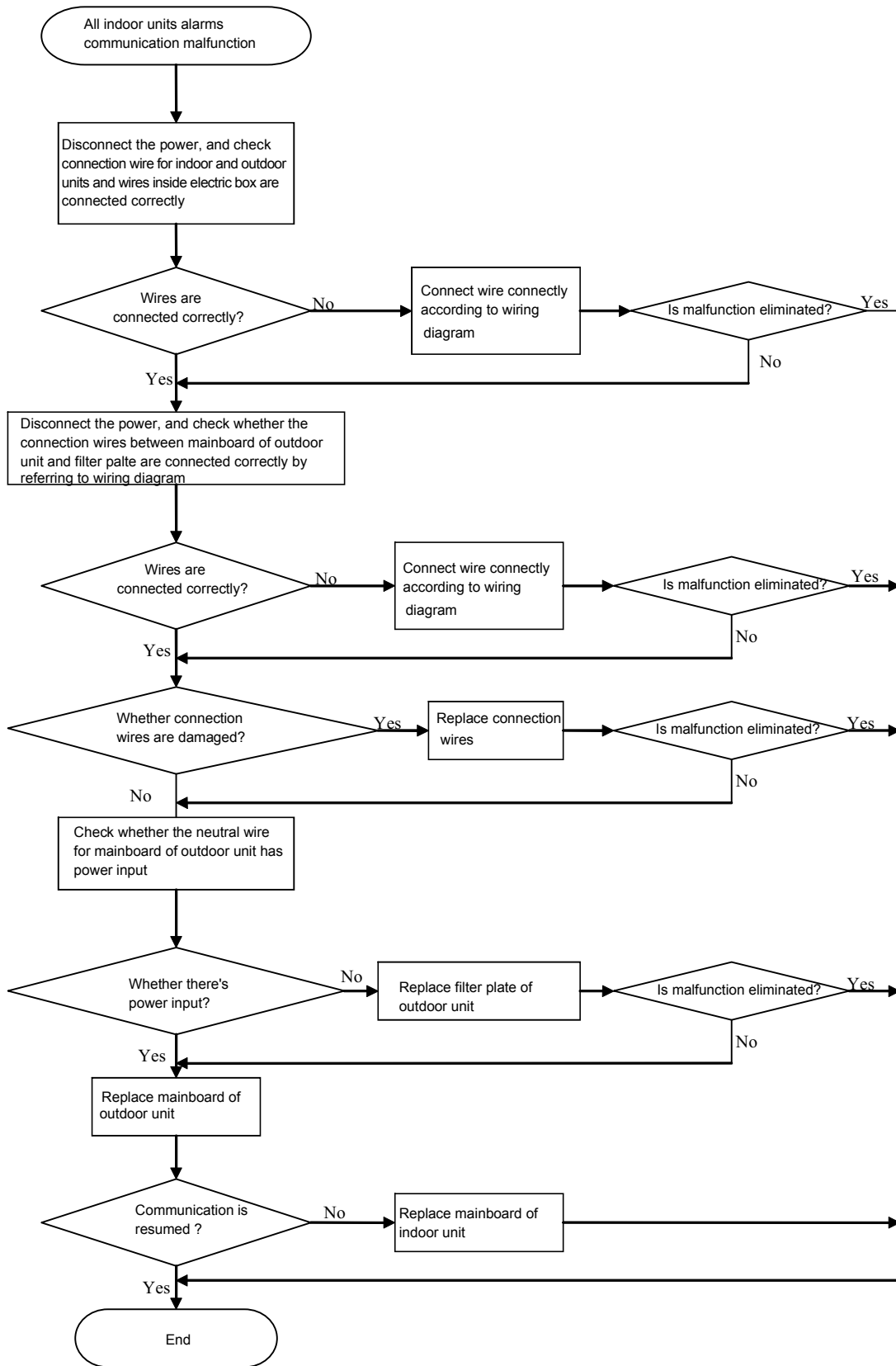

(3) Troubleshooting for C5 malfunction

Main causes for C5 malfunction; 1. Jumper cap hasn't been inserted on mainboard; 2. Jumper cap hasn't been inserted tightly; 3. Jumper cap is damaged; 4. The corresponding circuit of mainboard is abnormal. The check flow chart is as below:

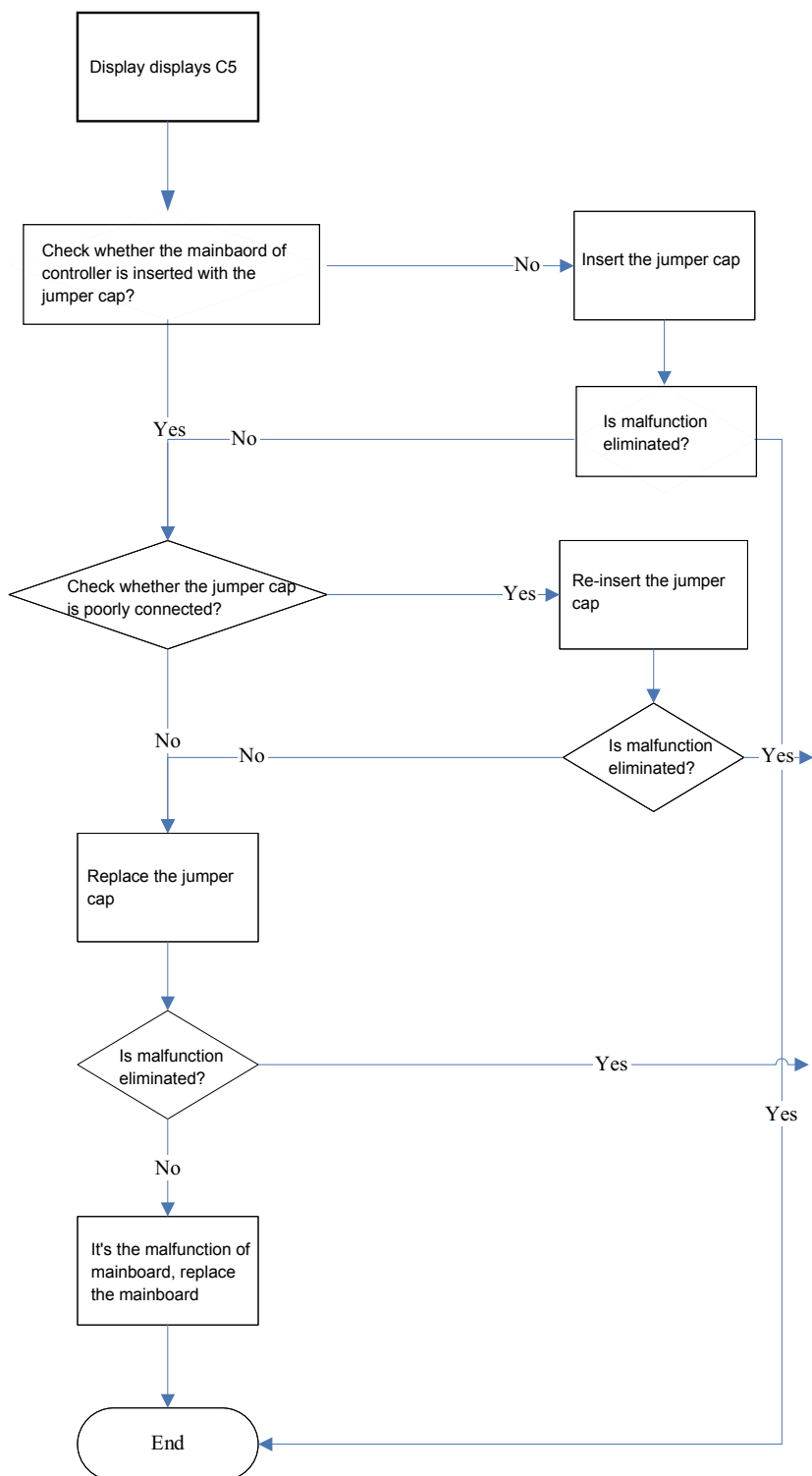

(4) Troubleshooting for H6 malfunction

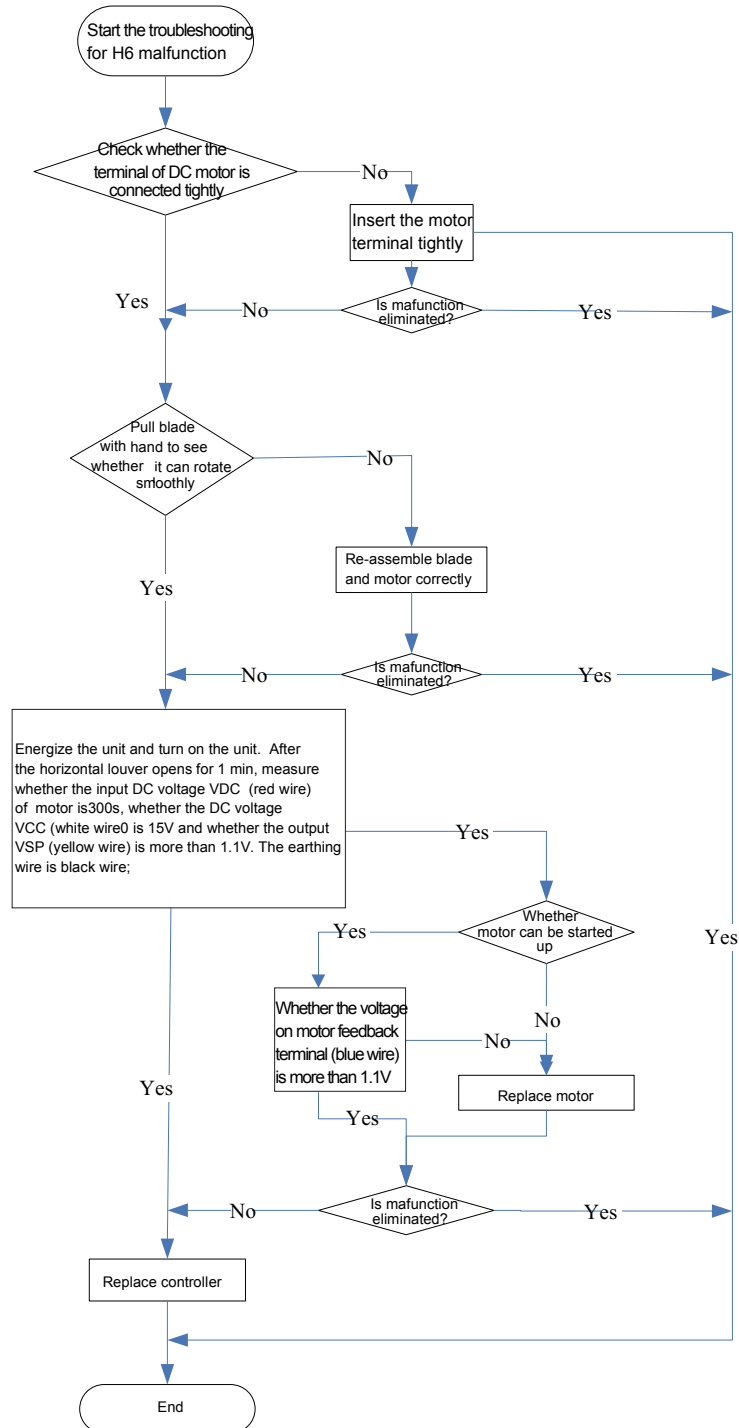

Note: The information above is for reference only.

## 10. Removal Procedure

**Warning** Be sure to wait for a minimum of 10 minutes after turning off all power supplies before disassembly.

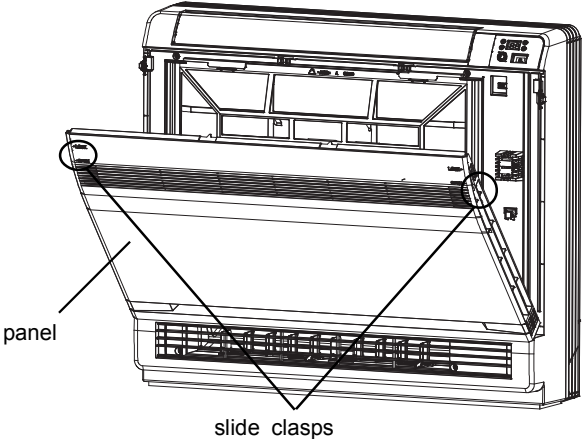
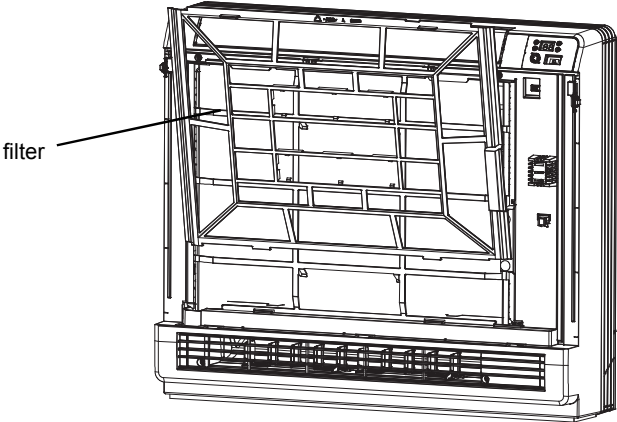
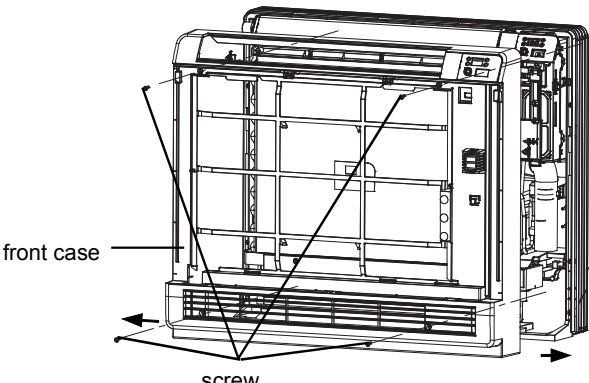
Steps	Procedure
1. Remove panel	<p>Pull the slide clasps at both sides of panel, pull the panel outwards, lift up the panel and then remove the panel.</p> 
2. Remove filter	<p>Loosen the clasp on the upper side of filter, pull the panel outwards to remove it.</p> 
3. Remove front case	<p>Remove the 4 screws fixing front case; Disengage the clasps on both sides (Follow the arrows); pull the front case outwards, and then remove the front case.</p> 

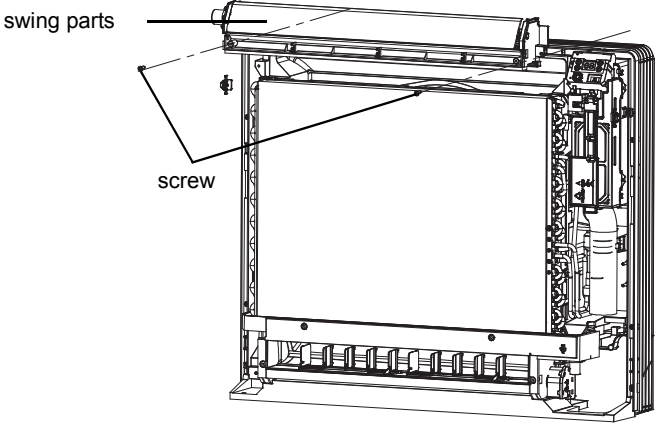
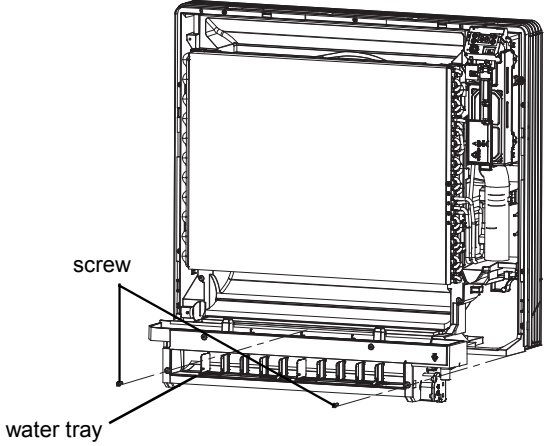
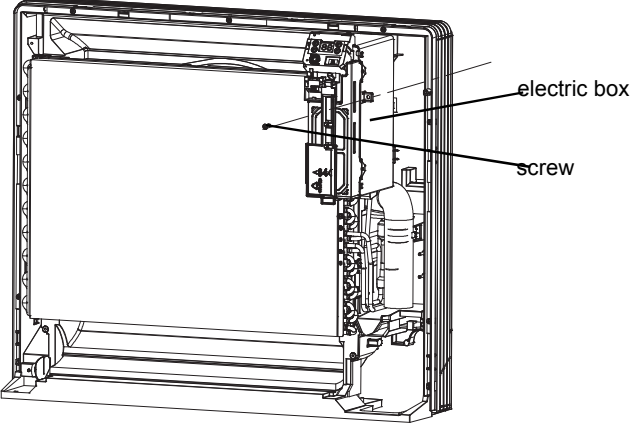
Steps	Procedure	
4. Remove swing parts	<p>Remove 2 screws fixing swing parts, pull out the connection wires between stepping motor and electric box, and then pull the swing parts outwards to remove it.</p>	 <p>The diagram shows a side view of the device's internal mechanism. Two screws are indicated by lines pointing to the top edge of the swing parts. The swing parts are shown being pulled outwards from the main frame.</p>
5. Remove water tray	<p>Remove 2 screws fixing water tray, and then pull the water tray outwards to remove it.</p>	 <p>The diagram shows a side view of the device. Two screws are indicated by lines pointing to the front edge of the water tray. The water tray is shown being pulled outwards from the bottom of the device.</p>
6. Remove electric box	<p>Remove one screw fixing electric box, pull out all connection wire, and then pull the electric box outwards to remove it.</p>	 <p>The diagram shows a side view of the device. One screw is indicated by a line pointing to the top of the electric box. The electric box is shown being pulled outwards from the top of the device.</p>

**Removal Procedure**

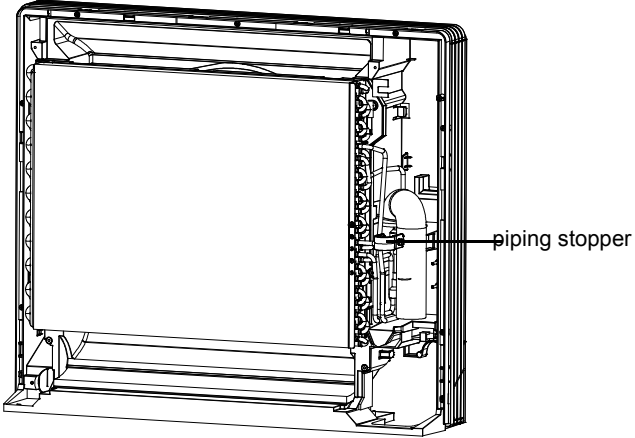
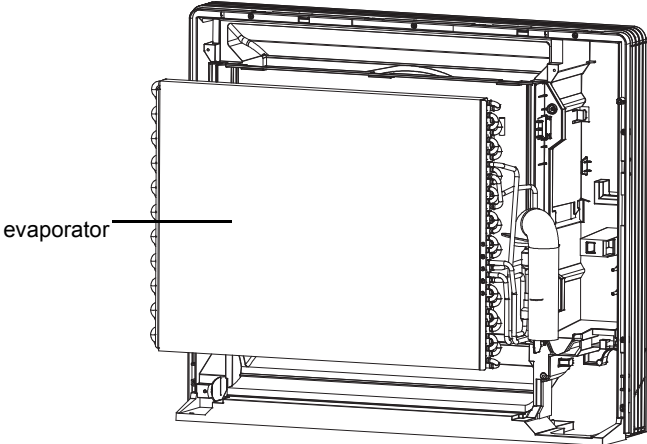
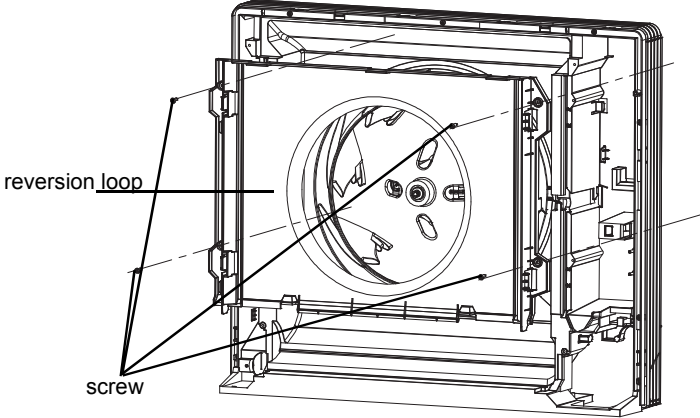
<b>Steps</b>	<b>Procedure</b>
7. Remove piping stopper	<p data-bbox="284 481 691 584">Loosen clasps between piping stopper and bottom case, and then pull the piping stopper outwards to remove it.</p>  <p data-bbox="1273 667 1417 689">piping stopper</p>
8. Remove evaporator	<p data-bbox="284 981 691 1084">Loosen the clasps between evaporator and bottom case and then pull the evaporator outwards to remove it.</p>  <p data-bbox="716 1198 826 1220">evaporator</p>
9. Remove reversion loop	<p data-bbox="284 1547 691 1610">Remove 4 screws on reversion loop, and then remove the reversion loop.</p>  <p data-bbox="727 1666 869 1688">reversion loop</p> <p data-bbox="810 1868 869 1890">screw</p>

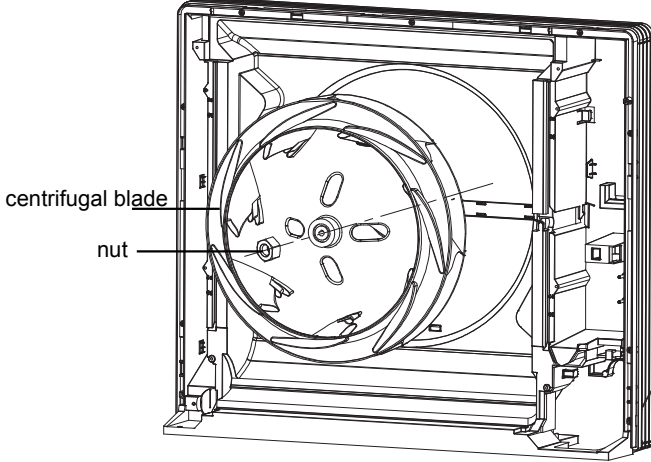
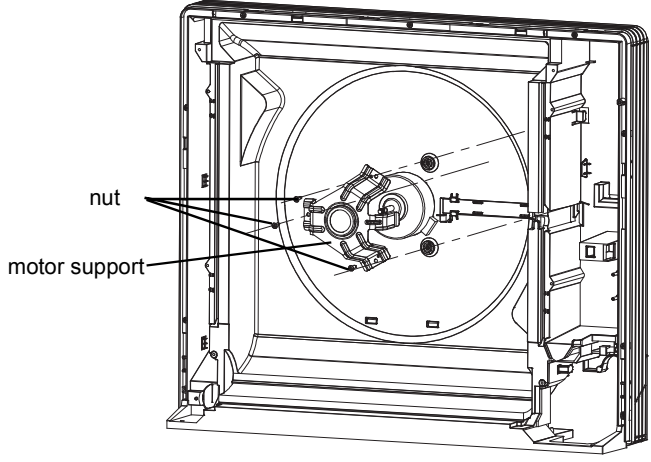
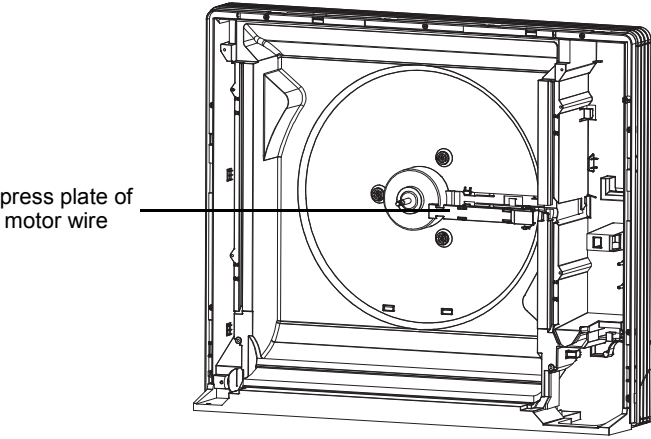
Steps	Procedure
10. Remove centrifugal blade	<p data-bbox="276 459 678 571">Remove nuts on centrifugal blade, and then pull the centrifugal blade outwards to remove it.</p>  <p>The diagram shows a centrifugal blade assembly mounted on a circular motor housing. Two nuts are shown on the blade, with lines pointing to them from the label 'nut'. The blade itself is labeled 'centrifugal blade'.</p>
11. Remove motor support	<p data-bbox="276 996 678 1064">Remove screws fixing motor support, and then remove the motor support.</p>  <p>The diagram shows a motor support assembly mounted on a circular motor housing. Two nuts are shown on the support, with lines pointing to them from the label 'nut'. The support itself is labeled 'motor support'.</p>
12. Remove press plate of motor wire	<p data-bbox="276 1545 678 1691">Loosen clasps between press plate of motor wire and bottom case, and then pull the press plate of motor wire to remove it.</p>  <p>The diagram shows a press plate of motor wire assembly mounted on a circular motor housing. The plate is labeled 'press plate of motor wire'.</p>

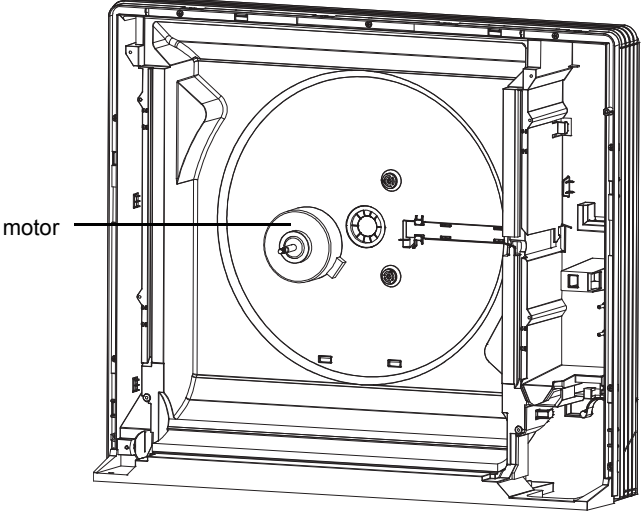

Steps	Procedure
13. Remove motor	<p data-bbox="300 497 491 526">Remove the motor.</p>  <p data-bbox="790 627 853 656">motor</p>



**GREE ELECTRIC APPLIANCES, INC.OF ZHUHAI**

---

Add:Jinji west Rd.Qianshan Zhuhai Guangdong China

Tel:86-756-8522219 (After sale Service Dept)

Post code: 519070