



Service Manual

**MODEL: GWH(09)MA-K3DNA2B/I
GWH(12)MB-K3DNA2B/I
GWH(18)MC-K3DNA2B/I
GWH(07)MA-K3DNA3B/I
GWH(09)MA-K3DNA3B/I
GWH(12)MB-K3DNA3B/I
GWH(18)MC-K3DNA3B/I
GWH(09)MA-K3DNB8B/I
GWH(12)MB-K3DNB8B/I
GWH(07)MA-K3DNC5B/I
GWH(09)MA-K3DNC5B/I
GWH(12)MB-K3DNC5B/I
GWH(18)MC-K3DNC5B/I
GWH(07)MA-K3DNB8B/I(Cold plasma)
GWH(09)MA-K3DNB8B/I(Cold plasma)
GWH(12)MB-K3DNB8B/I(Cold plasma)
GWH(18)MC-K3DNB8B/I(Cold plasma)**

GREE ELECTRIC APPLIANCES, INC.OF ZHUHAI

Summary and Features	1
Part 1 Safety Precautions	2
Part 2 Specifications	3
2.1 Unit Specifications	3
2.2 Capacity Variation Ratio According to Temperature.....	4
Part 3 Construction Views	5
Part 4 Refrigerant System Diagram	6
Part 5 Schematic Diagram	7
5.1 Electrical Data.....	7
5.2 Electrical Wiring.....	7
5.3 Printed Circuit Board.....	9
Part 6 Function and Control	11
6.1 Remote Control Operations	11
6.2 Description of Each Control Operation.....	15
Part 7 Installation Manual	18
7.1 Notices for Installation.....	18
7.2 Installation Drawing.....	19
7.3 Install Indoor Unit.....	20
7.4 Check After Installation and Test Operation.....	21
7.5 Installation and Maintenance of Healthy Filter.....	22
Part 8 Exploded Views and Parts List	23
Part 9 Troubleshooting	39
9.1 Malfunction Display.....	39
9.2 Troubleshooting	39
Part10 Removal Procedure	46

Summary and features

Indoor Unit

GWH(09)MA-K3DNA2B/I
GWH(12)MB-K3DNA2B/I
GWH(18)MC-K3DNA2B/I

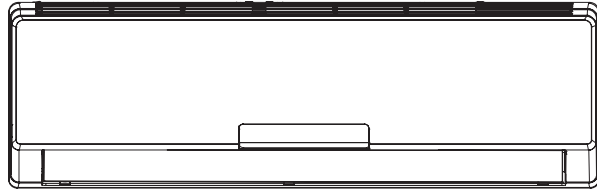

GWH(07)MA-K3DNA3B/I
GWH(09)MA-K3DNA3B/I
GWH(12)MB-K3DNA3B/I
GWH(18)MC-K3DNA3B/I

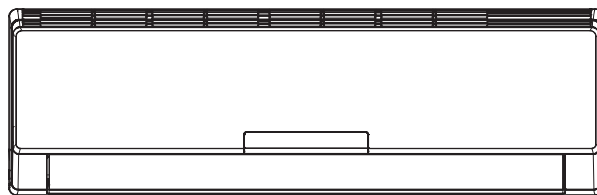

GWH(09)MA-K3DNB8B/I
GWH(12)MB-K3DNB8B/I
GWH(07)MA-K3DNB8B/I(Cold plasma)
GWH(09)MA-K3DNB8B/I(Cold plasma)
GWH(12)MB-K3DNB8B/I(Cold plasma)
GWH(18)MC-K3DNB8B/I(Cold plasma)

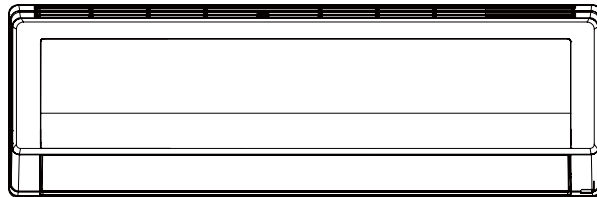

GWH(07)MA-K3DNC5B/I
GWH(09)MA-K3DNC5B/I
GWH(12)MB-K3DNC5B/I
GWH(18)MC-K3DNC5B/I



Remote Controller

YT1F



1.Safety Precautions



Installing, starting up, and servicing air conditioner can be hazardous due to system pressure, electrical components, and equipment location, etc.

Only trained, qualified installers and service personnel are allowed to install, start-up, and service this equipment. Untrained personnel can perform basic maintenance functions such as cleaning coils. All other operations should be performed by trained service personnel.

When handling the equipment, observe precautions in the manual and on tags, stickers, and labels attached to the equipment. Follow all safety codes. Wear safety glasses and work gloves. Keep quenching cloth and fire extinguisher nearby when brazing.

Read the instructions thoroughly and follow all warnings or cautions in literature and attached to the unit. Consult local building codes and current editions of national as well as local electrical codes.

Recognize the following safety information:

-  **Warning** Incorrect handling could result in personal injury or death.
-  **Caution** Incorrect handling may result in minor injury, or damage to product or property.

- Make sure the outdoor unit is installed on a stable, level surface with no accumulation of snow, leaves, or trash beside.
- Make sure the ceiling/wall is strong enough to bear the weight of the unit.
- Make sure the noise of the outdoor unit does not disturb neighbors.
- Follow all the installation instructions to minimize the risk of damage from earthquakes, typhoons or strong winds.
- Avoid contact between refrigerant and fire as it generates poisonous gas.
- Apply specified refrigerant only. Never have it mixed with any other refrigerant. Never have air remain in the refrigerant line as it may lead to rupture and other hazards.
- Make sure no refrigerant gas is leaking out when installation is completed.
- Should there be refrigerant leakage, the density of refrigerant in the air shall in no way exceed its limited value, or it may lead to explosion.
- Keep your fingers and clothing away from any moving parts.
- Clear the site after installation. Make sure no foreign objects are left in the unit.
- Always ensure effective grounding for the unit.

Warning

All electric work must be performed by a licensed technician according to local regulations and the instructions given in this manual.

- Before installing, modifying, or servicing system, main electrical disconnect switch must be in the OFF position. There may be more than 1 disconnect switch. Lock out and tag switch with a suitable warning label.
- Never supply power to the unit unless all wiring and tubing are completed, reconnected and checked.
- This system adopts highly dangerous electrical voltage. Incorrect connection or inadequate grounding can cause personal injury or death. Stick to the wiring diagram and all the instructions when wiring.
- Have the unit adequately grounded in accordance with local electrical codes.
- Have all wiring connected tightly. Loose connection may lead to overheating and a possible fire hazard.

All installation or repair work shall be performed by your dealer or a specialized subcontractor as there is the risk of fire, electric shock, explosion or injury.

Caution

- Never install the unit in a place where a combustible gas might leak, or it may lead to fire or explosion.
- Make a proper provision against noise when the unit is installed at a telecommunication center or hospital.
- Provide an electric leak breaker when it is installed in a watery place.
- Never wash the unit with water.
- Handle unit transportation with care. The unit should not be carried by only one person if it is more than 20kg.
- Never touch the heat exchanger fins with bare hands.
- Never touch the compressor or refrigerant piping without wearing glove.
- Do not have the unit operate without air filter.
- Should any emergency occur, stop the unit and disconnect the power immediately.
- Properly insulate any tubing running inside the room to prevent the water from damaging the wall.

2.Specifications

2.1 Unit Specifications

Model	GWH(07)MA-K3DNA3B/I GWH(07)MA-K3DNC5B/I GWH(07)MA- K3DNB8B/I(Cold plasma)	GWH(09)MA-K3DNA2B/I GWH(09)MA-K3DNA3B/I GWH(09)MA-K3DNB8B/I GWH(09)MA-K3DNC5B/I GWH(09)MA- K3DNB8B/I(Cold plasma)	GWH(12)MB-K3DNA2B/I GWH(12)MB-K3DNA3B/I GWH(12)MB-K3DNB8B/I GWH(12)MB-K3DNC5B/I GWH(12)MB- K3DNB8B/I(Cold plasma)	GWH(18)MC-K3DNA2B/I GWH(18)MC-K3DNA3B/I GWH(18)MC-K3DNC5B/I GWH(18)MC- K3DNB8B/I(Cold plasma)
Product Code	CB171N0400 CB179N00900 CB174N02100	CB181N02700 CB171N0340 CB174N01900 CB179N01000 CB174N01901	CB181N02800 CB171N0350 CB174N02000 CB179N01100 CB174N02001	CB181N02900 CB171N0360 CB179N01200 CB174N02200
Capacity(Cooling)(W)	2100	2600	3500	5300
Capacity(Heating)(W)	2600	2800	3800	5800
Fan Motor Speed (r/min) (SH/H/ML)	1200/1050/920/730	1260/1050/920/730	(1260)/1070/900/730	1350/1200/1050/900
Airflow(m ³ /h)	450	500	630	850
Output of Fan Motor (W)	10	10	20	20
Input Power of Heater (W)	/	/	/	/
Fan Motor Capacitor (μF)	1	1	1	1.5
Fan Motor RLA(A)	0.23	0.23	0.37	0.48
Fan Type	Cross flow fan	Cross flow fan	Cross flow fan	Cross flow fan
Diameter-Length (mm)	Φ85X596	Φ85X596	Φ92X645	Φ98X710
Evaporator	Aluminum fin-copper tube	Aluminum fin-copper tube	Aluminum fin-copper tube	Aluminum fin-copper tube
Pipe Diameter (mm)	Φ7	Φ7	Φ7	Φ7
Row-Fin Gap(mm)	2-1.5	2-1.5	2-1.4	2-1.4
Coil length (l)Xheight (H)X coil width (L)	581X264X25.4	581X264X25.4	645X267X25.4	715X304.8X25.4
Swing Motor Model	MP24AA	MP24AA	MP24AA	MP28VB
Output of Swing Motor (W)	1.5	1.5	1.5	2
Fuse (A)	PCB 3.15A	PCB 3.15A	PCB 3.15A	PCB 3.15A
Sound Pressure Level dB (A) (SH/H/M/L/SL)	36/34/31/28/-	37/34/31/28/-	38/34/32/30/-	46/43/40/36/-
Sound Power Level dB (A) (SH/H/M/L/SL)	46/44/41/38/-	47/44/41/38/-	48/44/42/40/-	56/53/40/36/-
Dimension (W/H/D) (mm)	790X265X170	790X265X170	845X275X180	940X298X200
Dimension of Package (L/W/H)(mm)	870X248X355	870X248X355	915X255X355	1010X285X380
Liquid connections Diameter	Φ6(1/4")	Φ6(1/4")	Φ6(1/4")	Φ6(1/4")
Gas connections Diameter	Φ9.52(3/8")	Φ9.52(3/8")	Φ9.52(3/8")	Φ12(1/2")
Net Weight /Gross Weight (kg)	9/12	9/12	10/13	13/17

The above data is subject to change without notice. Please refer to the nameplate of the unit.

2.2 Noise Criteria Curve Tables for Both Models

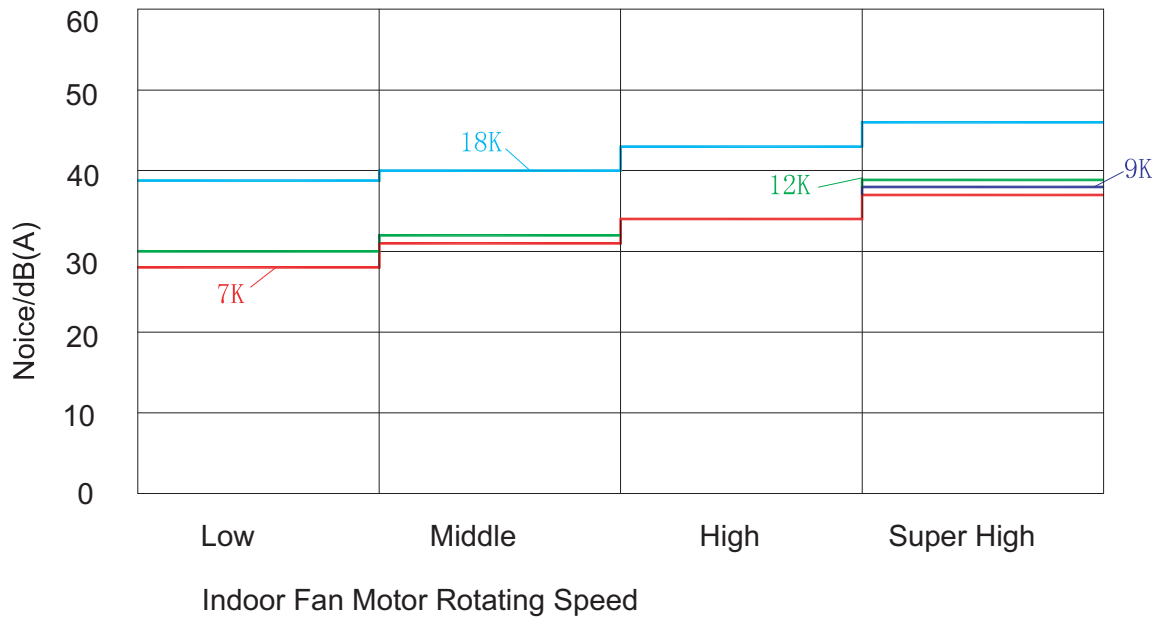

3. Construction Views

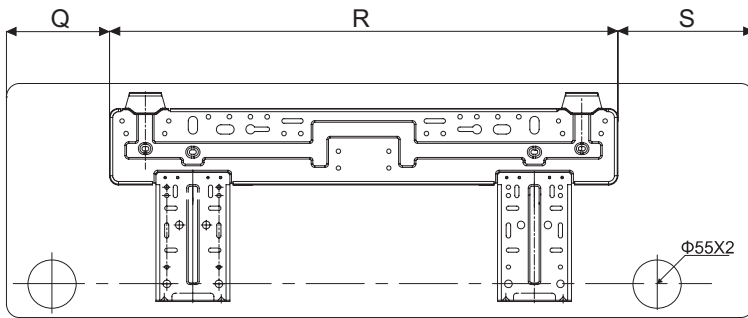
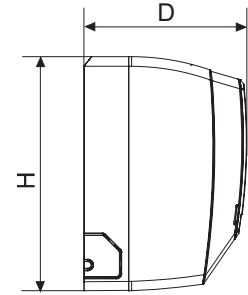
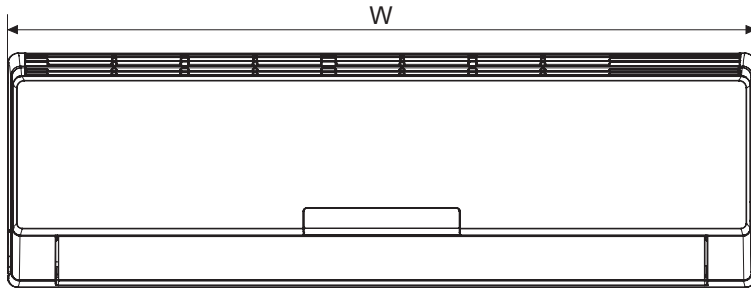

7K&09K

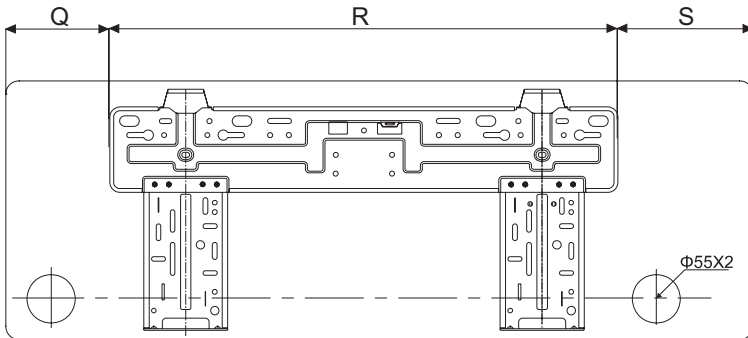

12K

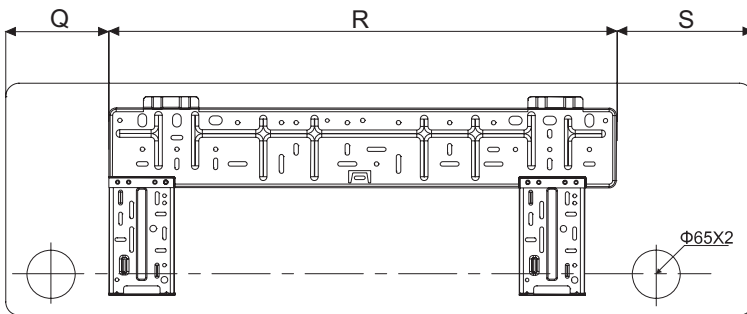

18K

Model(mm)	W	H	D	Q	R	S
7K&09K	790	265	170	35	605	150
12K	845	275	180	134	540	171
18K	940	298	200	108	694	138

4. Refrigerant System Diagram

Cooling & Heating Models

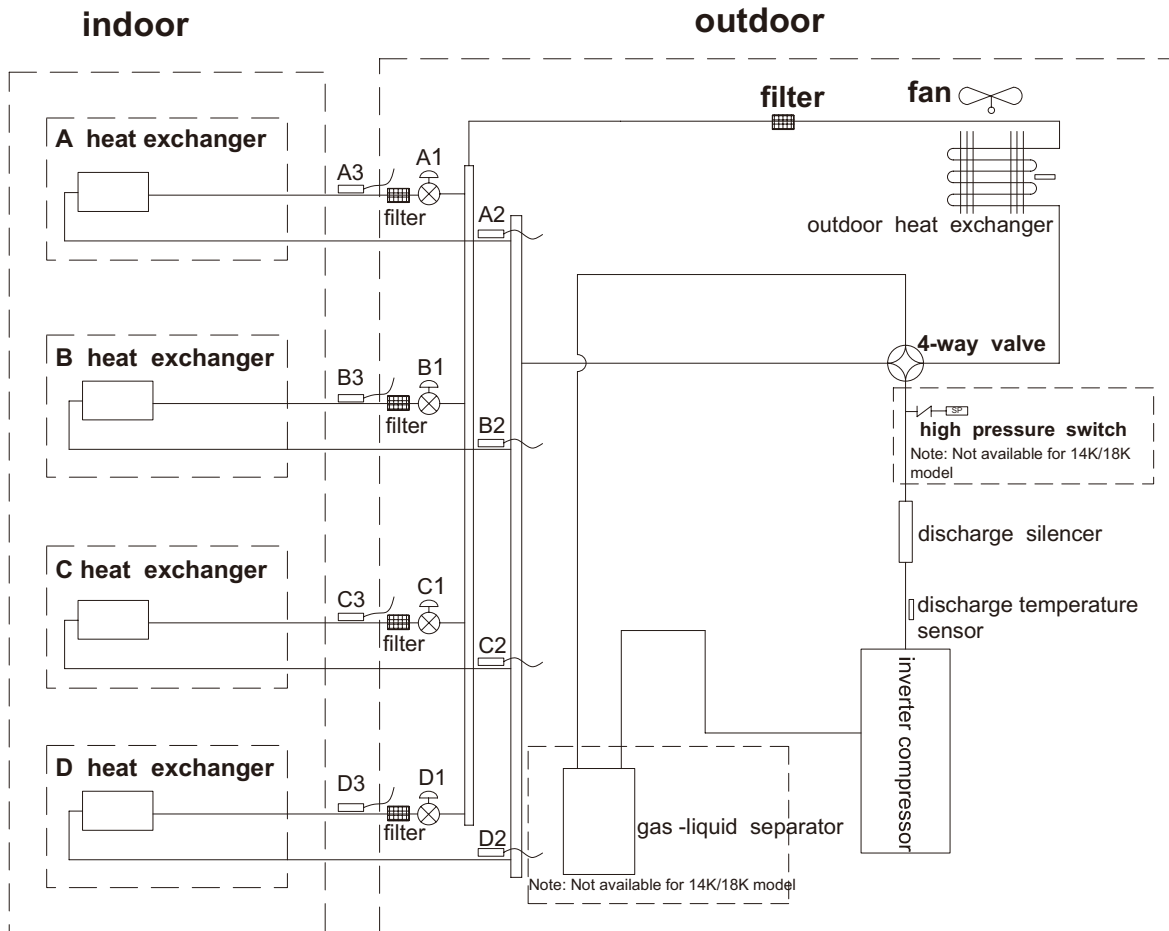

A1:A-unit electronic expansion valve B1:B-unit electronic expansion valve
 C1:C-unit electronic expansion valve D1:D-unit electronic expansion valve
 A2:A-unit gas pipe temperature sensor B2:B-unit gas pipe temperature sensor
 C2:C-unit gas pipe temperature sensor D2:D-unit gas pipe temperature sensor
 A3:A-unit liquid pipe temperature sensor B3:B-unit liquid pipe temperature sensor
 C3:C-unit liquid pipe temperature sensor D3:D-unit liquid pipe temperature sensor

5. Schematic Diagram

5.1 Electrical Data

Meaning of marks

Symbol	Color symbol	Symbol	Color symbol
WH	WHITE	BN	BROWN
YE	YELLOW	BU	BLUE
RD	RED	BK	BLACK
YEGN	YELLOW GREEN	VT	VIOLET
OG	ORANGE	⊕	PROTECTIVE EARTH
SAT	OVERLOAD	COMP	COMPRESSOR

5.2 Electrical Wiring

For 07/09/12K Unit

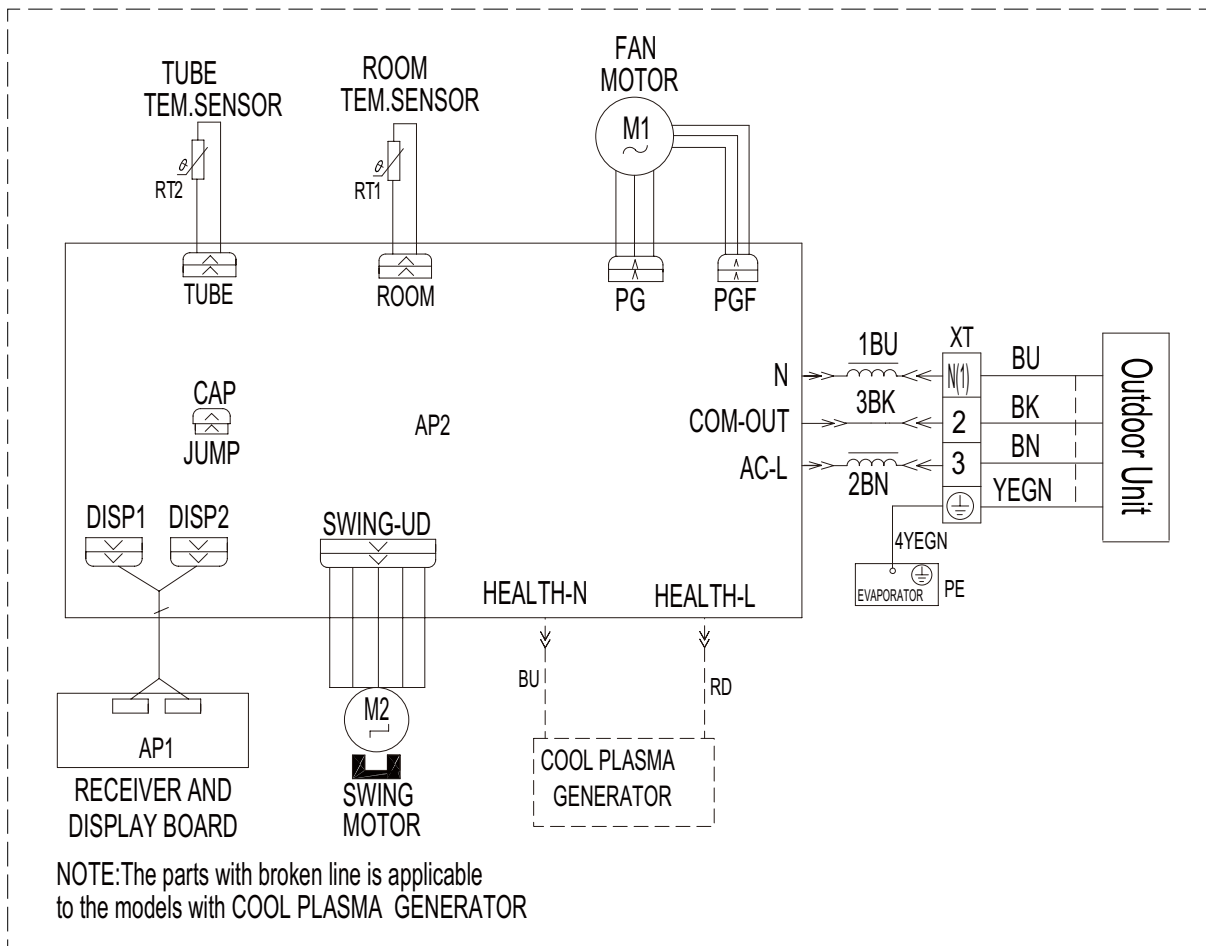

For 18K Unit

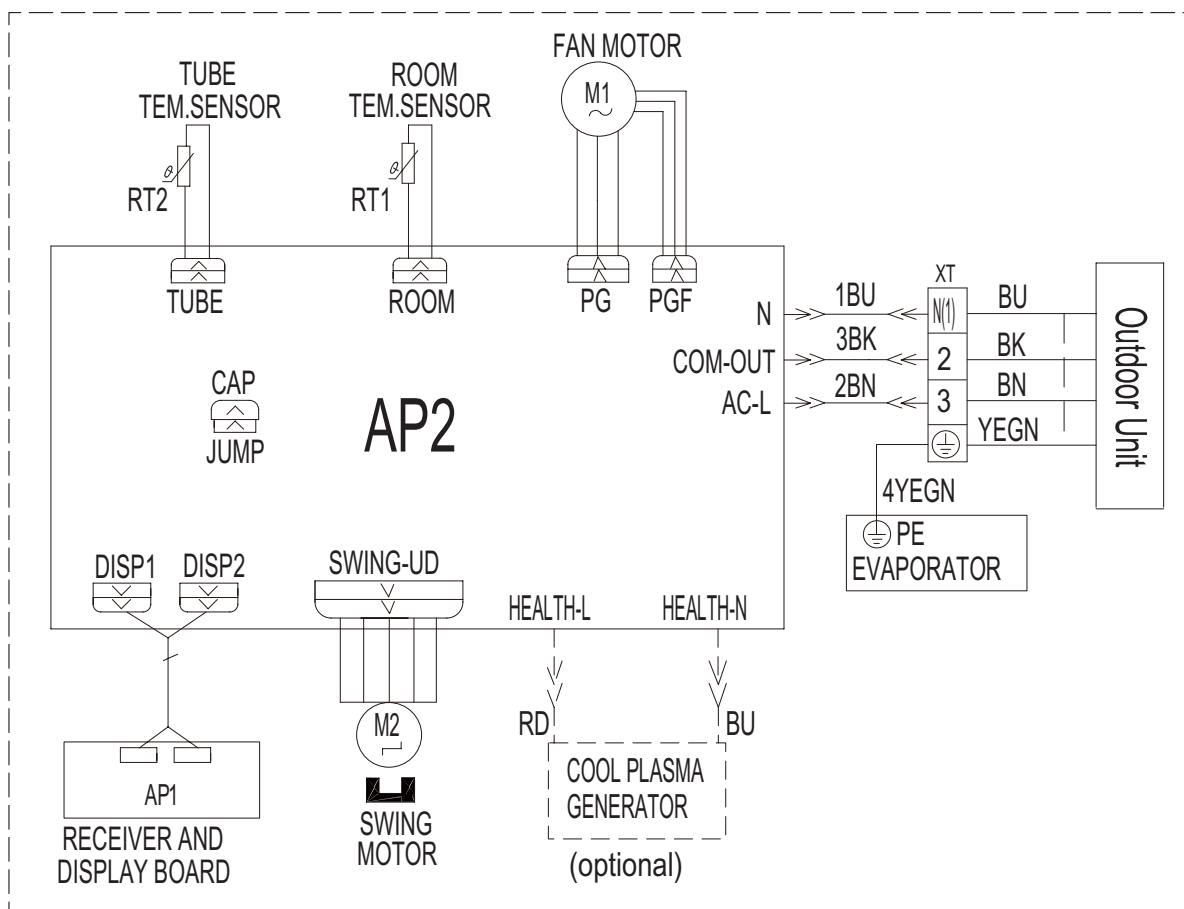

These circuit diagrams are subject to change without notice, please refer to the one supplied with the unit.

5.3 Printed Circuit Board

For 07/09/12K Unit

● TOP VIEW

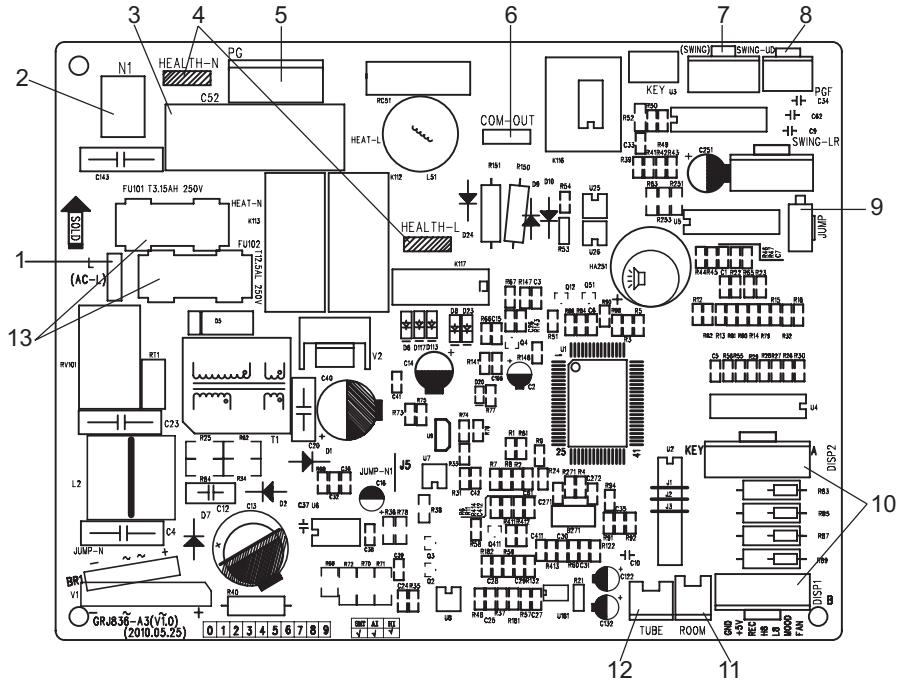

1	Power supply live wire connector	5	Indoor fan wire terminal	9	Jumper cap terminal
2	Power supply neutral wire connector	6	indoor and outdoor unit communication wire terminal	10	Display panel terminal
3	Fan capacitor	7	Up & down swing control terminal	11	Indoor ambient temperature sensor
4	Health function terminal(optional)	8	Indoor fan feedback terminal	12	Indoor pipe temperature sensor
				13	Protective tube

● BOTTOM VIEW

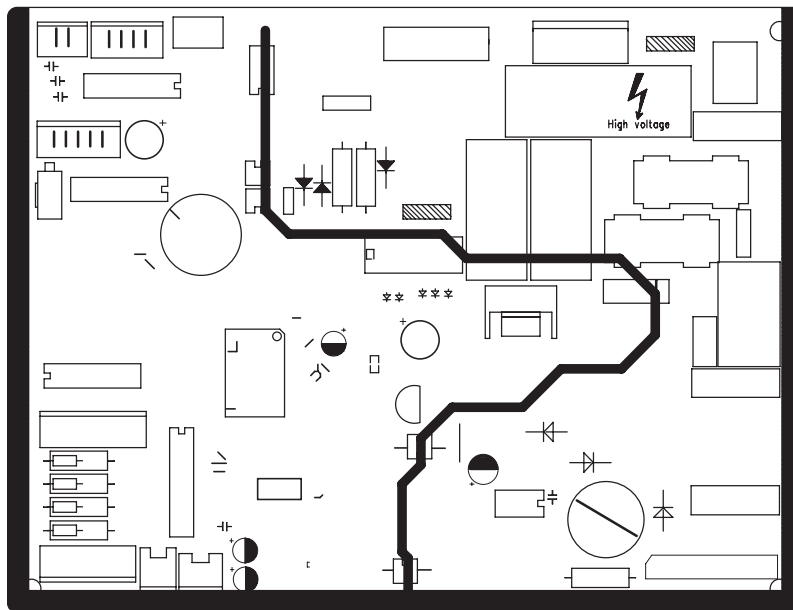

● TOP VIEW

For 18K Unit

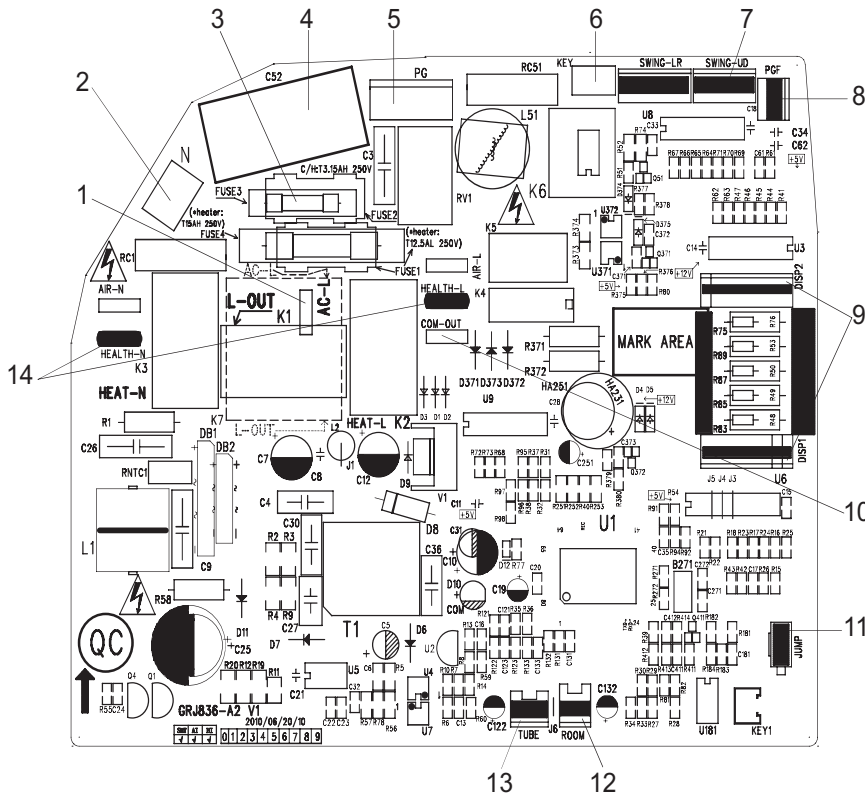

1	Power supply live wire connector
2	Power supply neutral wire connector
3	Protective tube
4	Fan capacitor
5	PG motor connector
6	Auto button
7	Up & down swing connector
8	PG motor fan feedback terminal
9	Display panel connector
10	Indoor and outdoor unit communication wire terminal
11	Jumper cap terminal
12	Indoor ambient temperature sensor
13	Indoor pipe temperature sensor
14	Health function terminal(optional)

● BOTTOM VIEW

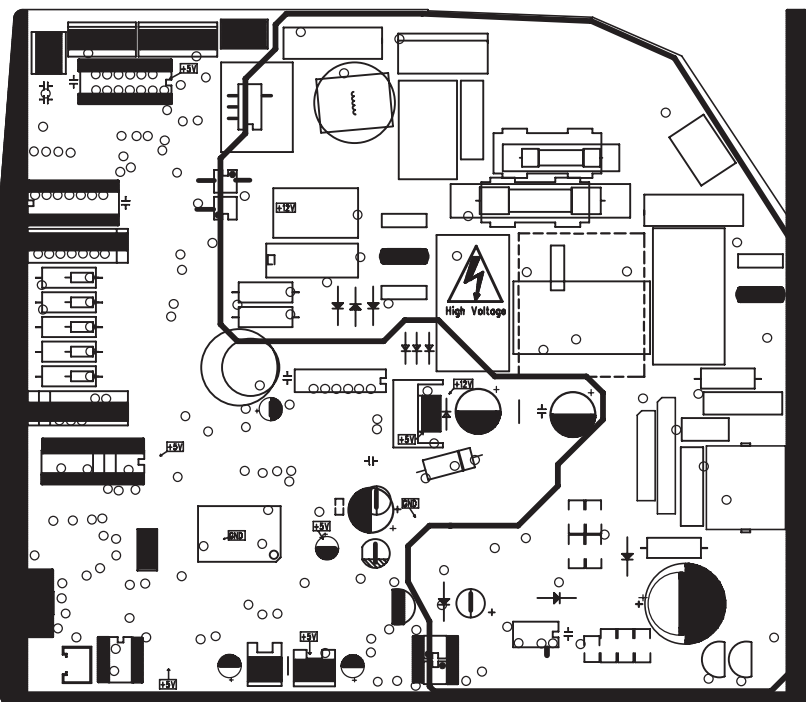

6. Function and Control

6.1 Remote Control Operations





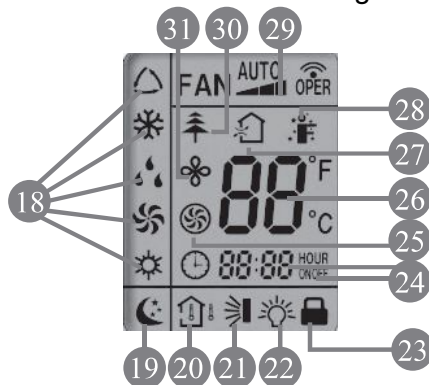









- 1 ON/OFF
Press it to start or stop operation.
- 2 - :
Press it to decrease temperature setting.
- 3 +:
Press it to increase temperature setting.
- 4 FAN
Press it to set fan speed.
- 5 MODE
Press it to select operation mode (AUTO/COOL/DRY/FAN/HEAT).
- 6 I FEEL
- 7
Press it to set HEALTH function
- 8
Press it to set AIR function.
- 9 CLOCK
Press it set clock.
- 10 TIMER ON
Press it to set auto-on timer.
- 11
Press it set swing angle.
- 12 X-FAN (X-FAN is the alternative expression of BLOW for the purpose of understanding.)
- 13 TEMP
- 14 TIMER OFF
Press it to set auto-off timer
- 15 TURBO
- 16 SLEEP
- 17 LIGHT
Press it to turn on/off the light.





18 MODE icon:

If MODE button is pressed, current operation mode icon (AUTO), (COOL), (DRY), (FAN) or (HEAT only for heat pump models) will show.

- 19 **SLEEP icon :**
 is displayed by pressing the SLEEP button. Press this button again to clear the display.
- 20 **TEMP icon:**
 Pressing TEMP button,  (set temperature),  (ambient temperature),  (outdoor ambient temperature) and blank is displayed circularly.
- 21 **Up & down swing icon:**
 is displayed when pressing the up & down swing button. Press this button again to clear the display.
- 22 **LIGHT icon:**
 is displayed by pressing the LIGHT button. Press LIGHT button again to clear the display.
- 23 **LOCK icon:**
 is displayed by pressing "+" and "-" buttons simultaneously. Press them again to clear the display.
- 24 **SET TIME display:**
 After pressing TIMER button, ON or OFF will blink. This area will show the set time.
- 25 **TURBO icon:**
 is displayed when pressing the TURBO button. Press this button again to clear the display.
- 26 **DIGITAL display:**
 This area will show the set temperature. In SAVE mode, "SE" will be displayed. During defrosting operation, "H1" will be displayed.
- 27 **AIR icon:**
 is displayed when pressing the AIR button. Press this button again to clear the display.
- 28 **I FEEL icon:**
 is displayed when pressing the I FEEL button. Press this button again to clear the display.
- 29 **FAN SPEED display:**
 Press FAN button to select the desired fan speed setting (AUTO Low-Med-High). Your selection will be displayed in the LCD windows, except the AUTO fan speed.
- 30 **HEALTH icon:**
 is displayed when pressing the HEALTH button. Press this button again to clear the display.
- 31 **X-FAN icon:**
 is displayed when pressing the X-FAN button. Press this button again to clear the display.

- 1 **ON/OFF:**
 Press this button to turn on the unit .Press this button again to turn off the unit.
- 2 **-:**
 Press this button to decrease set temperature. Hold it down for above 2 seconds to rapidly decrease set temperature. In AUTO mode, set temperature is not adjustable.
- 3 **+:**
 Press this button to increase set temperature. Hold it down for above 2 seconds to rapidly increase set temperature. In AUTO mode, set temperature is not adjustable.

- 4 **FAN :**
 This button is used for setting Fan Speed in the sequence that goes from AUTO,  ,  ,  to then back to Auto.

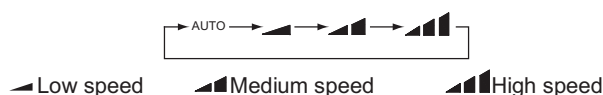

- 5 **MODE :**
 Each time you press this button, a mode is selected in a sequence that goes from AUTO, COOL, DRY, FAN, and HEAT *, as the following:



*Note: Only for models with heating function.

After energization, AUTO mode is defaulted. In AUTO mode, the set temperature will not be displayed on the LCD, and the unit will automatically select the suitable operation mode in accordance with the room temperature to make indoor room comfortable.

6 I FEEL:

Press this button to turn on I FEEL function. The unit automatically adjust temperature according to the sensed temperature. Press this button again to cancel I FEEL function.



7 

Press this button to set HEALTH function ON or OFF. After the unit is turned on, it defaults to HEALTH function ON.

8 

Press this button to select AIR function ON or OFF.

9 CLOCK :

Pressing CLOCK button,  blinks. Within 5 seconds, pressing + or - button adjusts the present time. Holding down either button above 2 seconds increases or decreases the time by 1 minute every 0.5 second and then by 10 minutes every 0.5 second. During blinking after setting, press CLOCK button again to confirm the setting, and then  will be constantly displayed.

10 TIMER ON :





Press this button to initiate the auto-ON timer. To cancel the auto-timer program, simply press this button again.



After pressing this button,  disappear sand " ON " blink s . 00:00 is displayed for ON time setting. Within 5 seconds, press + or - button to adjust the time value. Every press of either button changes the time setting by 1 minute. Holding down either button rapidly changes the time setting by 1 minute and then 10 minutes. Within 5 seconds after setting, press TIMER ON button to confirm.

11 

Press this button to set up & down swing angle, which circularly changes as below:



This remote controller is universal. If any command , or is sent out, , ,  the unit will carry out the command as 

 indicates the guide louver swings as: 

12 X-FAN:

Pressing X -FAN button in COOL or DRY mode, the icon  is displayed and the indoor fan will continue operation for 10 min utes in order to dry the indoor unit even though you have turned off the unit. After energization, X-FAN OFF is defaulted. X-FAN is not available in AUTO, FAN or HEAT mode.

13 TEMP:

Press this button, could select displaying the indoor setting temperature or indoor ambient temperature. When the indoor unit firstly power on it will display the setting temperature, if the temperature's displaying status is changed from other status to "  ", displays the ambient temperature, 5s later or within 5s, it receives other remote control signal that will return to display the setting temperature. if the users haven't set up the temperature displaying status, that will display the setting temperature.

14 TIMER OFF :

Press this button to initiate the auto-off timer. To cancel the auto-timer program, simply press the button again. TIMER OFF setting is the same as TIMER ON.

15 TURBO:

Press this button to activate / deactivate the Turbo function which enables the unit to reach the preset temperature in the shortest time. In COOL mode, the unit will blow strong cooling air at super high fan speed. In HEAT mode, the unit will blow strong heating air at super high fan speed.



16 SLEEP:

Press this button to go into the SLEEP operation mode. Press it again to cancel this function. This function is available in COOL, HEAT (Only for models with heating function) or DRY mode to maintain the most comfortable temperature for you.

17 LIGHT:

Press LIGHT button to turn on the display's light and press this button again to turn off the display's light. If the light is turned on,  is displayed. If the light is turned off,  disappears.

18 Combination of "+" and "-" buttons: About lock

Press "+" and "-" buttons simultaneously to lock or unlock the keypad. If the remote controller is locked,  is displayed. In this case, pressing any button,  blinks three times.

19 Combination of "MODE" and "-" buttons: About switch between Fahrenheit and Centigrade At unit OFF, press "MODE" and "-" buttons simultaneously to switch between $^{\circ}\text{C}$ and $^{\circ}\text{F}$.

Replacement of Batteries

1.Remove the battery cover plate from the rear of the remote controller.

(As shown in the figure)

2.Take out the old batteries.

3.Insert two new AAA1.5V dry batteries, and pay attention to the polarity.

4. Reinstall the battery cover plate.

★ Notes:

- When replacing the batteries, do not use old or different types of batteries, otherwise, it may cause malfunction.
- If the remote controller will not be used for a long time, please remove batteries to prevent batteries from leaking.
- The operation should be performed in its receiving range.
- It should be kept 1m away from the TV set or stereo sound sets.
- If the remote controller does not operate normally, please take the batteries out and reinsert them after 30 seconds. If it still can't operate properly, replace the batteries.

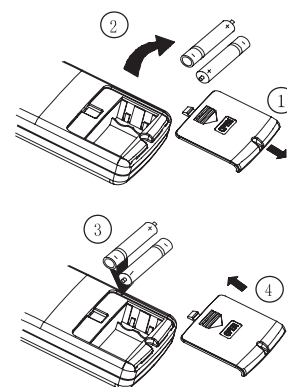

Sketch map for replacing batteries

6.2 Description of Each Control Operation

I. Basic Operation Mode

1. Cool; 2. Dry; 3. Heat; 4. Auto; 5. Fan

II. Basic Functions

1. Cooling Only

(1) Under this mode, fan and swing run at preset status, the temperature setting range is 16-30°C.

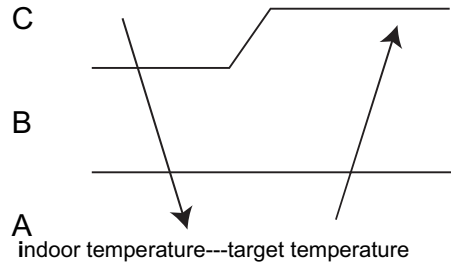

(2) Under malfunction for outdoor unit and protection stop, the indoor unit runs with the original status, and display malfunction.

(3) The indoor fan stops when the modes conflict with each other.

2. Dry Mode

(1) Under this mode, the indoor fan runs with low speed, and swing runs at preset status, the temperature setting range is 16-30°C.

(2) Under malfunction for outdoor unit and protection stop, the indoor unit runs with the original status, and display malfunction.

3. Heating Mode

(1) Under this mode, the temperature setting range is 16-30°C.

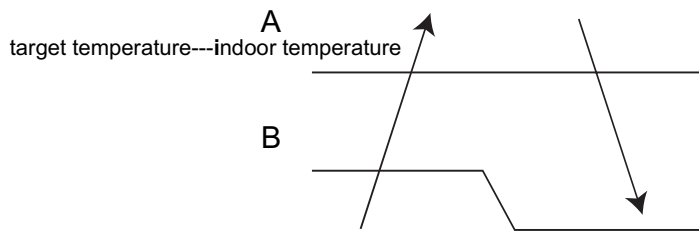

(2) Working condition and Process of Heating

When the unit is ON and in heating mode, indoor fan starts cold air prevention operation; when the unit is off and the indoor fan stopped before, it blows residual heat.

(3) Protection Function. The compressor stops as the malfunction (including any temperature sensor malfunction) in heating mode, the indoor fan runs with blowing residual heat.

4. Working Methods of Auto Mode

1) When $T_{amb} \geq 26^{\circ}\text{C}$ ($^{\circ}\text{F}$), it operates in Cool mode.

2) For heat pump unit, when $T_{amb} \leq 22^{\circ}\text{C}$, it operates in Heat mode.

3) When $22^{\circ}\text{C} < T_{amb} < 26^{\circ}\text{C}$, it operates in auto fan mode upon initial startup of the unit. When changing to auto mode from other modes, it will keep the previous operation mode (when it enter Dry mode, it operates in auto fan mode.).

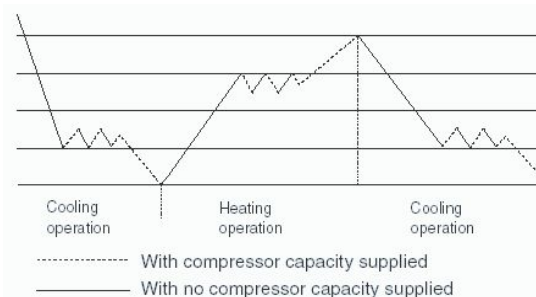

5. Fan Mode

Only indoor fan operates in Fan mode. Under auto fan speed, it runs in cooling auto fan mode.

III. Other Control

1. Buzzer

The buzzer will give out a beep when the controller is energized, receiving signal from remote controller and auto button.

2. Auto Button

Press this button once, it will operate in Auto mode, and indoor fan operates in Auto fan mode and swing. When the unit is on, pressing this button will turn off the unit.

3. Auto Fan

a. Auto fan speed in Heat mode

When $T_{amb} \leq T_{preset}$, the indoor fan operates at high speed;

When $T_{preset} < T_{amb} < T_{preset} + 2^{\circ}\text{C}$, the indoor fan operates at middle speed;

When $T_{amb} \geq T_{preset} + 2^{\circ}\text{C}$, the indoor fan operates at low speed.

b. Auto fan speed in Cool and Fan mode

When $T_{amb} \geq T_{preset} + 3^{\circ}\text{C}$, the indoor fan operates at high speed;

When $T_{preset} < T_{amb} < T_{preset} + 3^{\circ}\text{C}$, the indoor fan operates at middle speed;

When $T_{amb} \leq T_{preset} + 1^{\circ}\text{C}$, the indoor fan operates at low speed.

c. The auto fan speed is at low speed in Dry mode.

Note: Under auto fan speed, it will shift between high speed and middle speed, middle speed and low speed, high speed and low speed, the operation time must be 3.5min at least.

4. Sleep

4.1 The unit will select suitable sleep curve according to set temperature.

4.2 Sleep curve in Heat mode

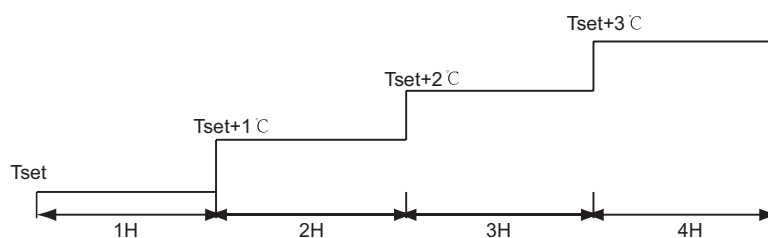

4.3 Sleep curve in Cool mode

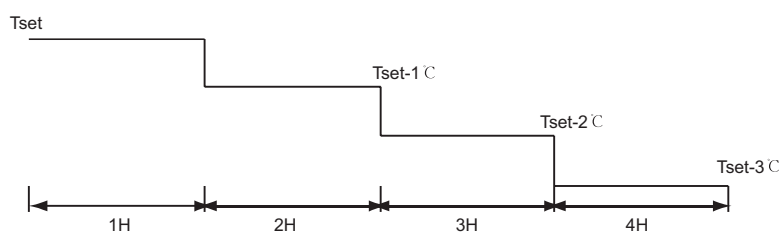

5. Timer Function

(1) General Timer:

1.1 Time On: if Timer On is set when the system is, the controller will operate in the original setting mode after reaching the timer on time. The timer interval is 0.5h, and the setting range is 0.5-24h.

1.2 Timer Off: Timer Off can be set when the unit is on. The unit will be off when timer off time is reached. The timer interval is 0.5h, and the setting range is 0.5-24h.

(2) Clock Timer:

2.1 Timer On: If Timer On is set when the system runs, it will continue to run; if Timer On is set when the system is off, the system will start to run in the original setting mode when timer on time is reached.

2.2 Timer Off: If timer off is set when the system is off, the system keeps stand-by status; if timer off is set when the system is on, the system stops when reaching timer off time.

2.3 Timer Change

Timer On and Timer OFF can be set via remote ON/OFF button. Timer time can be reset and the system will operate according to the latest setting.

When the unit is on and Timer On and Timer Off are both set, the system will operate according to the set state. When the timer off time is reached, the system will stop.

When the system stops, and Timer On and Timer Off are both set, the system will remain stop until timer on time is reached. After that, the unit will operate according to the set mode everyday when the timer on time is reached. When the timer off time is reached, the system will stop. If timer on time is the same as timer off time, the system will stop.

6. Memory Function

Memory contents: mode, up& down swing, light, set temperature, set fan speed, general timer (but clock timer). After power failure, if the unit is reenergized, it will operate according to memory contents. If Timer function is not set in the last remote control, the system will operate according to the last remote control.

If general timer function is set in the last remote control and power failure occurs before timer time is reached, the unit will operate according to the timer function set in the last remote control. Timer time is calculated after the unit is re-energized.

If general timer function is set in the last remote control and power failure occurs after timer time is reached, the system will operate according to the memory content before power failure. Timer operation is not memorized.

7. Health Function

When the unit is on and the indoor fan operates, press Health button to start this function (if there is no Health button, health operation is defaulted). When indoor fan stops or turning of health function by remote controller, health function will be off.

8. I Feel Function

When the controller receives I Feel order, the controller will operate according to the ambient temperature. The remote controller will send ambient temperature to the controller every 10min. If the controller does not receive the ambient temperature sent by remote controller for 11min, the air conditioner will operate according the ambient temperature around it. If I Feel function is not set, the air conditioner will operate according the ambient temperature around it. This function is not memorized upon power failure.

9. Reserved Fahrenheit Temperature

The nixie tube will display the set temperature in Celsius temperature or Fahrenheit Temperature according to the order. Setting range is 16~30°C (61~86°F). In Auto mode, it will display 25°C (77°F) during cooling and fan operation, and display 20°C (68°F) during heating operation. For cooling only unit, it displays 25°C (77°F).

The indoor temperature displayed is sent by remote controller, ranging from 0~60°C (32~99°F). If outdoor ambient temperature is received, the display remains the same. If valid control signal is received, it will display set temperature for 5s and then resume displaying ambient temperature.

For units with memory function, set temperature will be displayed after re-energizing the unit.

10. Cold Plasma Function

Turning on the cold plasma function with remote controller when the fan operates, this function will act.

Turning off the cold plasma function with remote controller or turning off the fan, this function will end.

12. Defrosting Mode Switch

If there is no H1 displayed, turn on the unit with remote controller and enter "Defrosting mode 1". When the indoor unit receives remote control signal, it will send the signal to the outdoor unit.

If there is H1 displayed, turn on the unit with remote controller and enter "Defrosting mode 2". When the indoor unit receives remote control signal, it will send the signal to the outdoor unit.

Press mode and auxiliary heating button to switch between "Defrosting mode 1" and "Defrosting mode 2".

13. Forcible Defrosting Function

When the unit is in Heat mode and set temperature is 16°C, press "+, -, +, -, +, -," successively for 5s, and the indoor unit will enter forcible defrosting setting and send the signal to the outdoor unit.

When the indoor unit receives forcible defrosting signal from the outdoor unit, it will exit forcible defrosting setting.

14. Refrigerant Recovery Function

Enter refrigerant recovery mode: turn on the unit within 5 min after energization and at 16°C cooling mode. Press remote controller light off button successively for 3 times within 3s and the unit will enter refrigerant recovery mode, displaying Fo. The signal will be sent to the outdoor unit.

Exit refrigerant recovery mode: during refrigerant recovery, if any signal from remote controller is received or refrigerant recovery lasts for 25min, it will exit this mode.

Action of entering refrigerant recovery mode: the indoor fan will operate in Cool mode. The fan speed is high and set temperature is 16°C. The horizontal louver will be at the smallest angle.

Action of exit refrigerant recovery mode: the indoor fan will operate according to the last remote control setting.

15. Pre-operation Function

When Cool mode at 30°C is set, press "-", +, -, +, -, +" successively for 3s, it will enter pre-operation mode. The signal will be sent to the outdoor unit.

Pre-operation mode: it performs cooling operation (indoor fan does not operate) and display "dd".

After exiting pre-operation mode, the indoor unit will stop displaying "dd". If the signal of "wrong wire connection or expansion valve malfunction" is received, "dn" will be displayed.

16. Mode Conflict

When the mode of started unit is different from that of operating unit, the indoor unit will display mode conflict code "E7". The mode sent to the outdoor unit remains the one received by the remote controller.

7. Installation Manual

7.1 Notices for Installation

Caution

- 1.The unit should be installed only by authorized service center according to local or government regulations and in compliance with this manual.
- 2.Before installing, please contact with local authorized maintenance center. If the unit is not installed by the authorized service center, the malfunction may not be solved due to inconvenient contact between the user and the service personnel.
- 3.When removing the unit to the other place, please firstly contact with the local authorized service center.
- 4.Warning: Before obtaining access to terminals, all supply circuits must be disconnected.
- 5.For appliances with type Y attachment, the instructions shall contain the substance of the following. If the supply cord is damaged, it must be replaced by the manufacturer, its service agent or similarly qualified persons in order to avoid a hazard.
- 6.The appliance must be positioned so that the plug is accessible.
- 7.The temperature of refrigerant line will be high; please keep the interconnection cable away from the copper tube.
- 8.The instructions shall state the substance of the following:
This appliance is not intended for use by persons(including children)with reduced physical, sensory or mental capabilities, or lack of experience and knowledge, unless they have been given supervision or instruction concerning use of the appliance by a person responsible for their safety.
Children should be supervised to ensure that they do not play with the appliance.

7.1.1 Installation Site Instructions

Proper installation site is vital for correct and efficient operation of the unit. Avoid the following sites where:

- strong heat sources, vapours, flammable gas or volatile liquids are emitted.
- high-frequency electro-magnetic waves are generated by radio equipment, welders and medical equipment.
- salt-laden air prevails (such as close to coastal areas).
- the air is contaminated with industrial vapours and oils.
- the air contains sulphures gas such as in hot spring zones.
- corrosion or poor air quality exists.

7.1.2 Installation Site of Indoor Unit

- 1.The air inlet and outlet should be away from the obstructions. Ensure the air can be blown through the whole room.
- 2.Select a site where the condensate can be easily drained out, and where it is easily connected to outdoor unit.
- 3.Select a place where it is out of reach of children.
- 4.Select a place where the wall is strong enough to withstand the full weight and vibration of the unit.
- 5.Be sure to leave enough space to allow access for routine maintenance. The installation site should be 250cm or more above the floor.
- 6.Select a place about 1m or more away from TV set or any other electric appliance.
- 7.Select a place where the filter can be easily taken out.
- 8.Make sure that the indoor unit is installed in accordance with installation dimension instructions.
- 9.Do not use the unit in the laundry or by swimming pool etc.

7.1.3 Safety Precautions for Electric Appliances

- 1.A dedicated power supply circuit should be used in accordance with local electrical safety regulations.
- 2.Don't drag the power cord with excessive force.
- 3.The unit should be reliably earthed and connected to an exclusive earth device by the professionals.
- 4.The air switch must have the functions of magnetic tripping and heat tripping to prevent short circuit and overload.
- 5.The minimum distance between the unit and combustive surface is 1.5m.
- 6.The appliance shall be installed in accordance with national wiring regulations.
- 7.An all-pole disconnection switch with a contact separation of at least 3mm in all poles should be connected in fixed wiring.

Note:

- Make sure the live wire, neutral wire and earth wire in the family power socket are properly connected. There should be reliable circuit in the diagram.
- Inadequate or incorrect electrical connections may cause electric shock or fire.

7.1.4 Earthing Requirements

1. Air conditioner is type I electric appliance. Please ensure that the unit is reliably earthed.
2. The yellow-green wire in air conditioner is the earthing wire which can not be used for other purposes. Improper earthing may cause electric shock.
3. The earth resistance should accord to the national criterion.
4. The power must have reliable earthing terminal. Please do not connect the earthing wire with the following:
 - ① Water pipe
 - ② Gas pipe
 - ③ Contamination pipe
 - ④ Other place that professional personnel consider is unreliable
5. The model and rated values of fuses should accord with the silk print on fuse cover or related PCB.

7.2 Installation Drawing

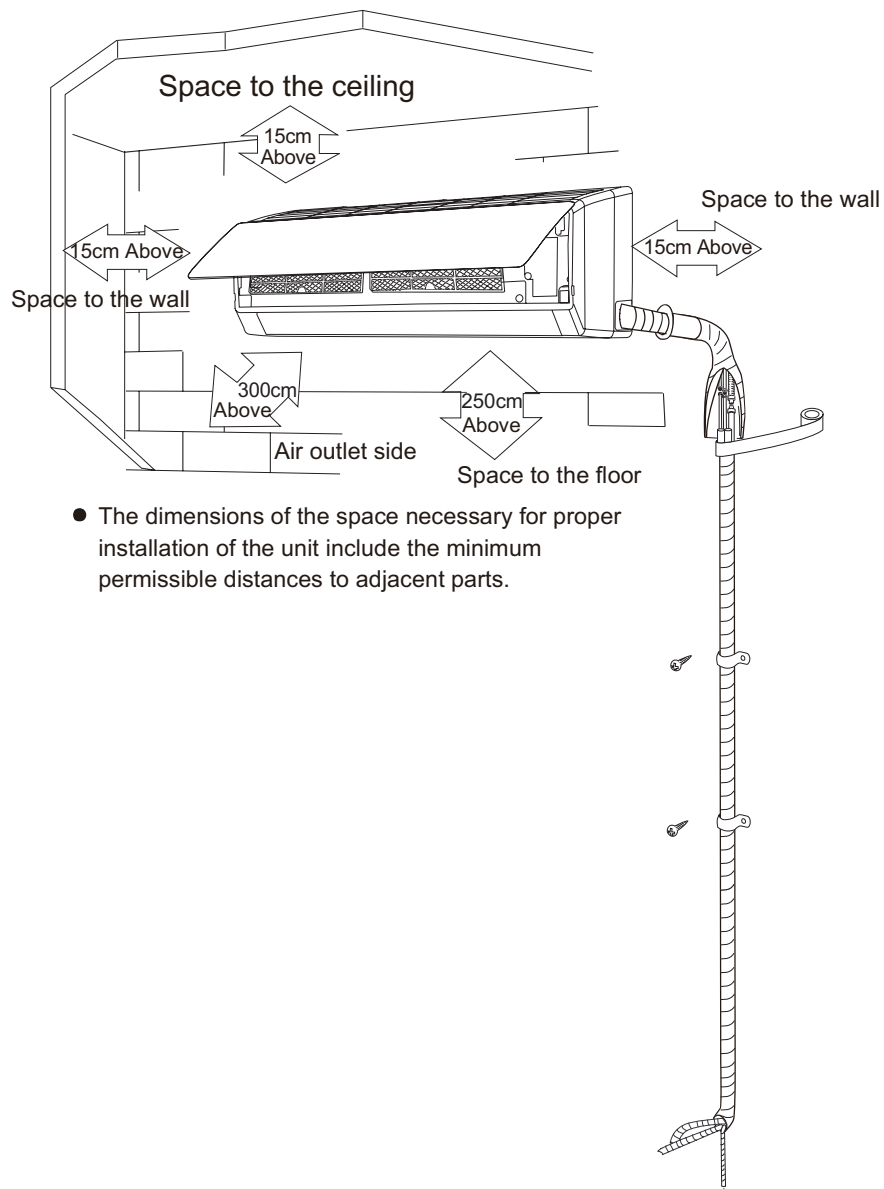

7.3 Install Indoor Unit

7.3.1 Installation of Mounting Plate

1. Mounting plate should be installed horizontally. As the water tray's outlet for the indoor unit is two-way type, during installation, the indoor unit should slightly slant to water tray's outlet for smooth drainage of condensate.
 2. Fix the mounting plate on the wall with screws.
 3. Be sure that the mounting plate has been fixed firmly enough to withstand about 60 kg. Meanwhile, the weight should be evenly shared by each screw.
- (Note: the wall hole for 18K unit is $\Phi 65\text{mm}$.)

09K UNIT:

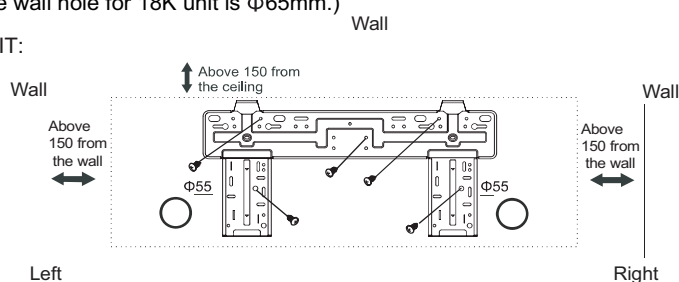

7.3.2 Drill Piping Hole

1. Make the piping hole ($\Phi 55$) in the wall at a slight downward slant to the outdoor side. (Note: the wall hole for 18K unit is $\Phi 65\text{mm}$.)
2. Insert the piping-hole sleeve into the hole to prevent the connection piping and wiring from being damaged when passing through the hole.

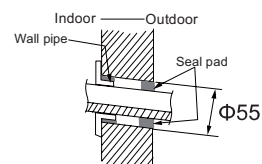

7.3.3 Installation of Drain Hose

1. Connect the drain hose to the outlet pipe of the indoor unit. Bind the joint with rubber belt.
2. Put the drain hose into insulating tube.
3. Wrap the insulating tube with wide rubber belt to prevent the shift of insulating tube. Slant the drain hose downward slightly for smooth drainage of condensate.

Note: The insulating tube should be connected reliably with the sleeve outside the outlet pipe. The drain hose should be slanted downward slightly, without distortion, bulge or fluctuation. Do not put the outlet in the water.

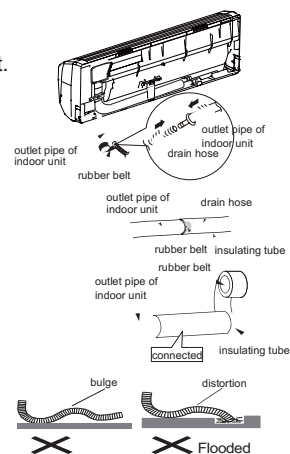

7.3.4 Connecting Indoor and Outdoor Electric Wires

1. Open the front panel.
2. Remove the wiring cover as shown in Fig 6.
3. Make the power connection cord pass through the hole at the back of indoor unit.
4. Reinstall the cord anchorage and wiring cover.
5. Reinstall the front panel.

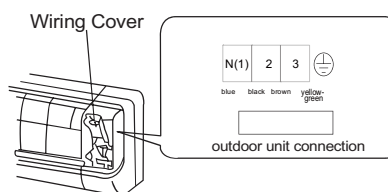

Fig.6

NOTE:

All wires between indoor and outdoor units must be connected by the qualified electric contractor.

- Electric wires must be connected correctly. Improper connection may cause malfunction.
- Tighten the terminal screws tightly.
- After tightening the screws, pull the wire slightly to confirm whether it's firm or not.
- Make sure that the electric connections are earthed properly to prevent electric shock.
- Make sure that all wiring connections are secure and the cover plates are reinstalled properly. Poor installation may cause fire or electric shock.

7.3.5 Installation of Indoor Unit

•The piping can be output from right, right rear, left or left rear.

1.When routing the piping and wiring from the left or right side of indoor unit, cut off the tailings from the chassis when necessary(As shown in Fig.7)

- (1) Cut off tailing 1 when routing the wiring only;
- (2) Cut off tailing 1 and tailing 2 when routing both the wiring and piping.

2.Take out the piping from body case; wrap the piping, power cords, drain hose with the tape and then make them pass through the piping hole. (As shown in Fig.8)

3.Hang the mounting slots of the indoor unit on the upper hooks of the mounting plate and check if it is firm enough. (As shown in Fig.9)

4.The installation site should be 250cm or more above the floor.

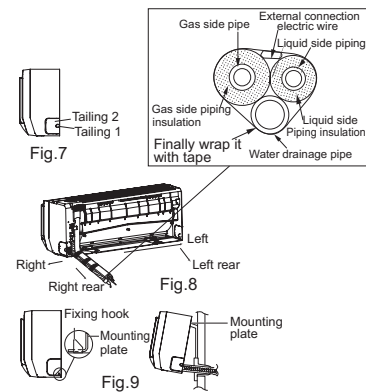

7.3.6 Installation of Connection Pipe

- 1.Align the center of the pipe flare with the related valve.
- 2.Screw in the flare nut by hand and then tighten the nut with spanner and torque wrench by referring to the following:

Tube diameter	Tightening torque, approximate(N·m)
Φ6.35(1/4")	14~18N·m(140-180kgf.cm)
Φ9.52(3/8")	34~42N·m(340-420kgf.cm)
Φ12.7(1/2")	49~61N·m(490-610kgf.cm)
Φ15.88(5/8")	68~82N·m(680-820kgf.cm)

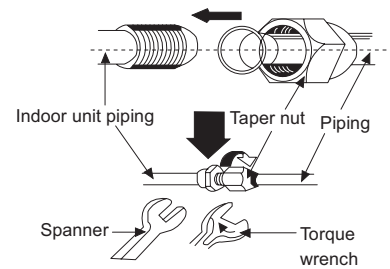

NOTE: Connect the connection pipe to indoor unit at first and then to outdoor unit. Handle piping bending with care. Do not damage the connection pipe. Ensure that the joint nut is tightened firmly, otherwise, it may cause leakage.

7.4 Check after Installation and Operation Test

7.4.1 Check after Installation

Items to be checked	Possible malfunction
Has it been fixed firmly?	The unit may drop, shake or emit noise.
Have you done the refrigerant leakage test?	It may cause insufficient cooling(heating) capacity
Is heat insulation sufficient?	It may cause condensation and dripping.
Is water drainage satisfactory?	It may cause condensation and dripping.
Is the voltage in accordance with the rated voltage marked on the nameplate?	It may cause electric malfunction or damage the product.
Is the electric wiring and piping connection installed correctly and securely?	It may cause electric malfunction or damage the part.
Has the unit been connected to a secure earth connection?	It may cause electrical leakage.
Is the power cord specified?	It may cause electric malfunction or damage the part.
Are the inlet and outlet openings blocked?	It may cause insufficient cooling(heating) capacity.
Is the length of connection pipes and refrigerant capacity been recorded?	The refrigerant capacity is not accurate.

7.4.2 Operation Test

1. Before Operation Test

- (1) Do not switch on power before installation is finished completely.
- (2) Electric wiring must be connected correctly and securely.
- (3) Cut-off valves of the connection pipes should be opened.
- (4) All the impurities such as scraps and thums must be cleared from the unit.

2. Operation Test Method

- (1) Switch on power and press "ON/OFF" button on the remote controller to start operation.
- (2) Press MODE button to select the COOL, HEAT (Not available for cooling only unit), FAN to check whether the operation is normal or not.

7.5 Installation and Maintenance of Healthy Filter

7.5.1 Installation of Healthy Filter

1. Lift up the front panel from its two ends, as shown by the arrow direction, and then remove the air filter. (as shown in Fig.a)

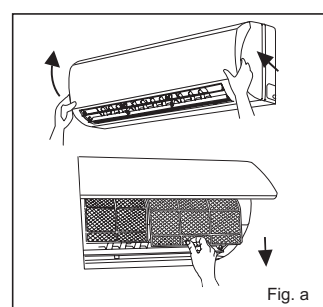

2. Attach the healthy filter onto the air filter, (as shown in Fig.b).

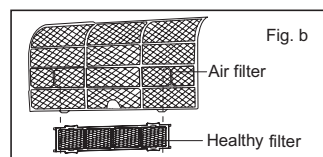

3. Install the air filter properly along the arrow direction in Fig.c, and then close the panel.

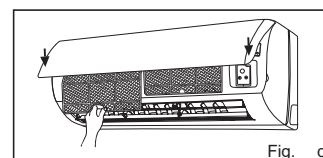

7.5.2 Cleaning and Maintenance

Remove the healthy filter and reinstall it after cleaning according to the installation instruction. Don't use brush or hard things to clean the filter. After cleaning, be sure to dry it in the shade.

7.5.3 Service Life

The general service life for the healthy filter is about one year under normal condition. As for silver ion filter, it is invalid when its surface becomes black (green).

- This supplementary instruction is provided for reference to the unit with healthy filter. If the graphics provided herein is different from the actual product, please refer to the actual product. The quantity of healthy filters is based on the actual delivery.

8. Exploded Views and Parts List

Models: GWH(07)MA-K3DNA3B/I GWH(07)MA-K3DNC5B/I GWH(09)MA-K3DNA2B/I
GWH(09)MA-K3DNA3B/I GWH(09)MA-K3DNB8B/I GWH(09)MA-K3DNC5B/I

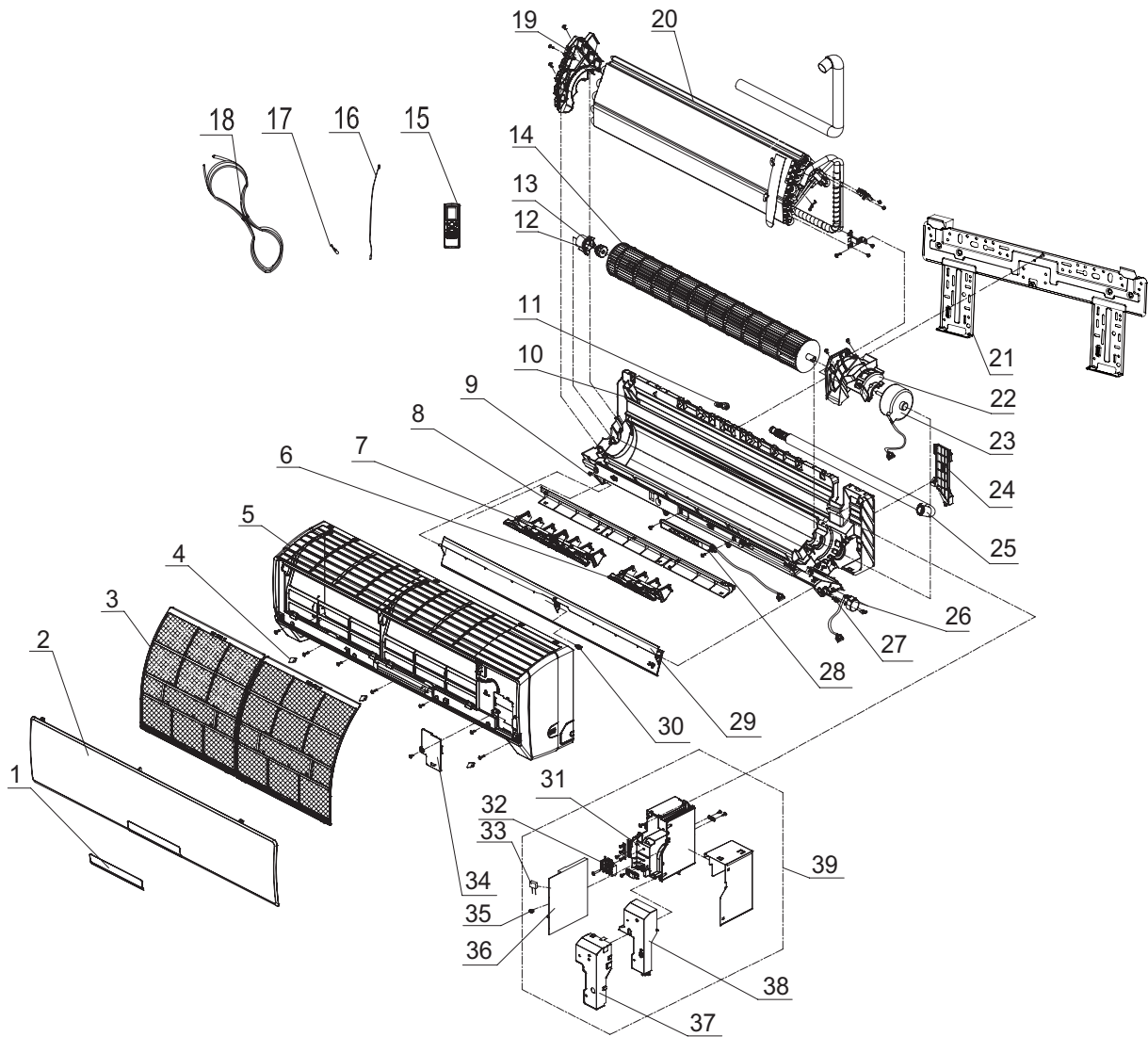

No.	Description	Part Code		Qty
		GWH(07)MA-K3DNA3B/I	GWH(07)MA-K3DNC5B/I	
		Product Code		
		CB171N0400	CB179N00900	
1	Receiver Window	20192229	22432194	1
2	Front Panel Assy	20012241	20012611	1
3	Filter Sub-Assy	11122081	11122081	2
4	Screw Cover	24252016	24252016	3
5	Front Case	20012120C	20012179C	1
6	Air Louver 2	10512114	10512114	1
7	Air Louver 1	10512113	10512113	1
8	Helicoid tongue	26112162	26112162	1
9	Axile Bush	10542704	10542704	1
10	Rear Case assy	2220210101	2220210101	1
11	Rubber Plug (Water Tray)	76712012	76712012	1
12	Ring of Bearing	26152022	26152022	1
13	O-Gasket sub-assy of Bearing	76512051	76512051	1
14	Cross Flow Fan	10352018	10352018	1
15	Remote Controller	30510049	305100492	1
16	Tube Sensor	390000591	390000591	1
17	Ambient Temperature Sensor	390000453	390000453	1
18	Connecting Cable	400204056	400204056	0
19	Evaporator Support	24212090	24212090	1
20	Evaporator Assy	0100274301	0100274301	1
21	Wall Mounting Frame	01252015	01252015	1
22	Motor Press Plate	26112160	26112160	1
23	Fan Motor	15012115	15012115	1
24	Pipe Clamp	26112164	26112164	1
25	Drainage hose	0523001406	0523001406	1
26	Step Motor	1521210801	1521210801	1
27	Crank	10582070	10582070	1
28	Display Board	30565007	3056504301	1
29	Guide Louver	10512111	10512111	1
30	Axile Bush	10542704	10542008	1
31	Electric Box	2011210501	2011210501	1
32	Terminal Board	42011233	42011233	1
33	Capacitor CBB61	33010002	33010002	1
34	Electric Box Cover2	20122075	20122075	1
35	Jumper	4202300101	4202300101	1
36	Main Board	30138655	30138655	1
37	Shield cover of Electric Box sub-assy	0159207301	0159207301	1
38	Electric Box Cover1	20122103	20122103	1
39	Electric Box Assy	2020209919	2020209923	1

The data above are subject to change without notice.

Exploded Views and Parts list

No.	Description	Part Code		Qty
		GWH(09)MA-K3DNA3B/I	GWH(09)MA-K3DNA2B/I	
		Product Code		
		CB171N0340	CB181N02700	
1	Receiver Window	20192229	20192229	1
2	Front Panel Assy	20012121S	20012142S	1
3	Filter Sub-Assy	11122081	11122081	2
4	Screw Cover	24252016	24252016	3
5	Front Case	20012120C	20012120C	1
6	Air Louver 2	10512114	10512114	1
7	Air Louver 1	10512113	10512113	1
8	Helicoid tongue	26112162	26112162	1
9	Axile Bush	10542704	10542704	1
10	Rear Case assy	2220210101	2220210101	1
11	Rubber Plug (Water Tray)	76712012	76712012	1
12	Ring of Bearing	26152022	26152022	1
13	O-Gasket sub-assy of Bearing	76512051	76512051	1
14	Cross Flow Fan	10352018	10352018	1
15	Remote Controller	30510049	305100492	1
16	Tube Sensor	390000591	390000591	1
17	Ambient Temperature Sensor	390000453	390000453	1
18	Connecting Cable	400204056	400204056	0
19	Evaporator Support	24212090	24212090	1
20	Evaporator Assy	0100274301	0100274301	1
21	Wall Mounting Frame	01252015	01252015	1
22	Motor Press Plate	26112160	26112160	1
23	Fan Motor	15012115	15012115	1
24	Pipe Clamp	26112164	26112164	1
25	Drainage hose	0523001406	0523001406	1
26	Step Motor	1521210801	1521210801	1
27	Crank	10582070	10582070	1
28	Display Board	30565007	30565056	1
29	Guide Louver	10512111	10512111	1
30	Axile Bush	10542704	10542704	1
31	Electric Box	2011210501	2011210501	1
32	Terminal Board	42011233	42011233	1
33	Capacitor CBB61	33010002	33010002	1
34	Electric Box Cover2	20122075	20122075	1
35	Jumper	4202300101	4202300101	1
36	Main Board	30138655	30138655	1
37	Shield cover of Electric Box sub-assy	0159207301	0159207301	1
38	Electric Box Cover1	20122103	20122103	1
39	Electric Box Assy	2020209919	20202906	1

The data above are subject to change without notice.

No.	Description	Part Code		Qty
		GWH(09)MA-K3DNB8B/I	GWH(09)MA-K3DNC5B/I	
		Product Code		
		CB174N01900	CB179N01000	
1	Receiver Window	/	22432194	1
2	Front Panel	2001232601	20012586S	1
3	Filter Sub-Assy	11122081	11122081	2
4	Screw Cover	24252016	24252016	3
5	Front Case	20012120C	20012179C	1
6	Air Louver 2	10512114	10512114	1
7	Air Louver 1	10512113	10512113	1
8	Helicoid Tongue	26112162	26112162	1
9	Axile Bush	10542704	10542704	1
10	Rear Case assy	2220210101	2220210101	1
11	Rubber Plug (Water Tray)	76712012	76712012	1
12	Ring of Bearing	26152022	76712012	1
13	O-Gasket sub-assy of Bearing	76512051	76512051	1
14	Cross Flow Fan	10352018	10352018	1
15	Remote Controller	305100492	305100492	1
16	Tube Sensor	390000591	390000591	1
17	Ambient Temperature Sensor	390000453	390000453	1
18	Connecting Cable	400204056	400204056	0
19	Evaporator Support	24212090	24212090	1
20	Evaporator Assy	0100274301	0100274301	1
21	Wall Mounting Frame	01252015	01252015	1
22	Motor Press Plate	26112160	26112160	1
23	Fan Motor	15012115	15012115	1
24	Pipe Clamp	26112164	26112164	1
25	Drainage Hose	0523001406	0523001406	1
26	Step Motor	1521210801	1521210801	1
27	Crank	10582070	10582070	1
28	Display Board	30565007	3056504301	1
29	Guide Louver	10512111	10512111	1
30	Axile Bush	10542008	10542008	1
31	Electric Box	2011210501	2011210501	1
32	Terminal Board	42011233	42011233	1
33	Capacitor CBB61	33010002	33010002	1
34	Electric Box Cover2	20122075	20122075	1
35	Jumper	4202300101	4202300101	1
36	Main Board	30138655	30138655	1
37	Shield Cover of Electric Box Sub-assy	0159207301	0159207301	1
38	Electric Box Cover1	20122103	20122103	1
39	Electric Box Assy	2020209919	2020209923	1

The data above are subject to change without notice.

Exploded Views and Parts list

**Model: GWH(12)MB-K3DNA2B/I GWH(12)MB-K3DNA3B/I
GWH(12)MB-K3DNB8B/I GWH(12)MB-K3DNC5B/I**

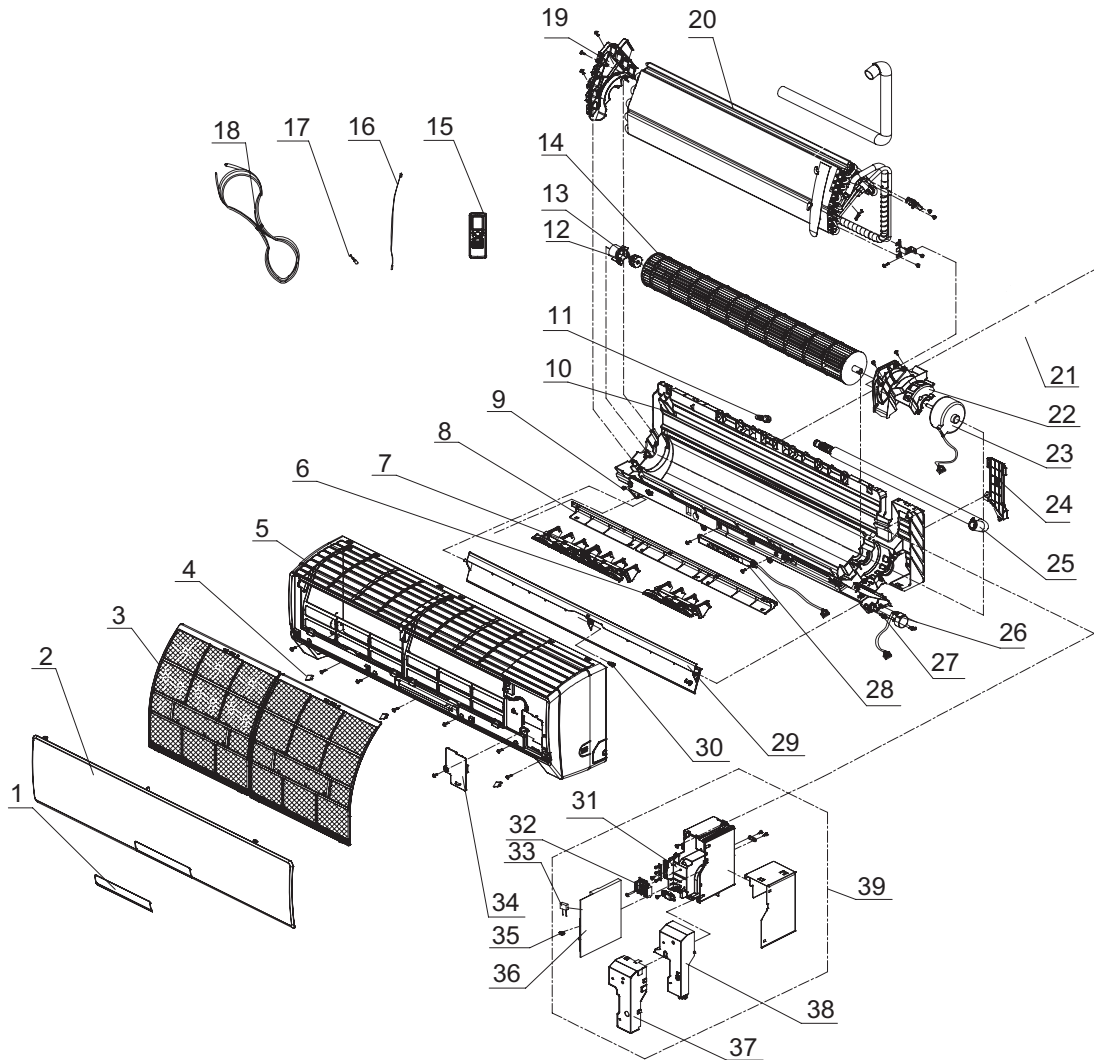

No.	Description	Part Code		Qty
		GWH(12)MB-K3DNA3B/I	GWH(12)MB-K3DNA2B/I	
		Product Code		
		CB171N0350	CB181N02800	
1	Receiver Window	22432230	22432230	1
2	Front panel B1	20012122S	20012150S	1
3	Filter Sub-Assy	1112220403	1112220403	1
4	Screw Cover	24252016	24252016	1
5	Front Case Sub-Assy	2001213908	2001213908	1
6	Air Louver 2	10512155	10512155	1
7	Air Louver 1	10512156	10512156	1
8	Helicoid tongue	26112163	26112163	1
9	Left Axile Bush	10512037	10512037	1
10	Rear Case assy	2220210301	2220210301	1
11	Rubber Plug (Water Tray)	76712012	76712012	1
12	Ring of Bearing	26152022	26152022	1
13	O-Gasket sub-assy of Bearing	76512051	76512051	1
14	Cross Flow Fan	10352017	10352017	1
15	Remote Controller	30510049	305100492	1
16	Tube Sensor	390000591	390000591	1
17	Ambient Temperature Sensor	390000453	390000453	1
18	Connecting Cable	400204056	400204056	0
19	Evaporator Support	24212091	24212091	1
20	Evaporator Assy	0100274401	0100274401	1
21	Wall Mounting Frame	01252021	01252021	1
22	Motor Press Plate	26112161	26112161	1
23	Fan Motor	150120874	150120874	1
24	Pipe Clamp	26112164	26112164	1
25	Drainage hose	0523001401	0523001401	1
26	Step Motor	1521210801	1521210801	1
27	Crank	10582070	10582070	1
28	Display Board	30565007	30565056	1
29	Guide Louver	10512157	10512157	1
30	Axile Bush	10542008	10542008	1
31	Electric Box	2011210501	2011210501	1
32	Terminal Board	42011233	42011233	1
33	Capacitor CBB61	33010002	33010002	1
34	Electric Box Cover2	20122075	20122075	1
35	Jumper	4202300105	4202300105	1
36	Main Board	30138655	30138655	1
37	Shield cover of Electric Box sub-assy	0159207301	0159207301	1
38	Electric Box Cover1	20122103	20122103	1
39	Electric Box Assy	2020210001	2020210004	1

The data above are subject to change without notice.

Exploded Views and Parts list

No.	Description	Part Code		Qty
		GWH(12)MB-K3DNB8B/I	GWH(12)MB-K3DNC5B/I	
		Product Code		
		CB174N02000	CB179N01100	
1	Receiver Window	22432230	22432230	1
2	Front Panel 11	20012204	20012614	1
3	Filter Sub-Assy	1112220403	1112220403	2
4	Screw Cover	24252016	24252016	1
5	Front Case Sub-assy	2001213908	2001213915	1
6	Air Louver 2	10512155	10512155	1
7	Air Louver 1	10512156	10512156	1
8	Helicoid Tongue	26112163	26112163	1
9	Left Axile Bush	10512037	10512037	1
10	Rear Case assy	2220210301	2220210301	1
11	Rubber Plug (Water Tray)	76712012	76712012	1
12	Ring of Bearing	26152022	26152022	1
13	O-Gasket sub-assy of Bearing	76512051	76512051	1
14	Cross Flow Fan	10352017	76512203	1
15	Remote Controller	305100492	305100492	1
16	Tube Sensor	390000591	390000591	1
17	Ambient Temperature Sensor	390000453	390000453	1
18	Connecting Cable	400204056	400204056	0
19	Evaporator Support	24212091	24212091	1
20	Evaporator Assy	0100274401	0100274401	1
21	Wall Mounting Frame	01252021	01252021	1
22	Motor Press Plate	26112161	26112161	1
23	Fan Motor	150120874	150120874	1
24	Pipe Clamp	26112164	26112164	1
25	Drainage Hose	0523001401	0523001401	1
26	Step Motor	1521210801	1521210801	1
27	Crank	10582070	10582070	1
28	Display Board	30565007	3056504301	1
29	Guide Louver	10512157	10512157	1
30	Axile Bush	10542008	10542008	1
31	Electric Box	2011210501	2011210501	1
32	Terminal Board	42011233	42011233	1
33	Capacitor CBB61	33010002	33010002	1
34	Electric Box Cover2	20122075	20122075	1
35	Jumper	4202300105	4202300105	1
36	Main Board	30138655	30138655	1
37	Shield Cover of Electric Box Sub-assy	0159207301	0159207301	1
38	Electric Box Cover1	20122103	20122103	1
39	Electric Box Assy	2020210001	2020210003	1

The data above are subject to change without notice.

Model: GWH(18)MC-K3DNA2B/I GWH(18)MC-K3DNA3B/I GWH(18)MC-K3DNC5B/I

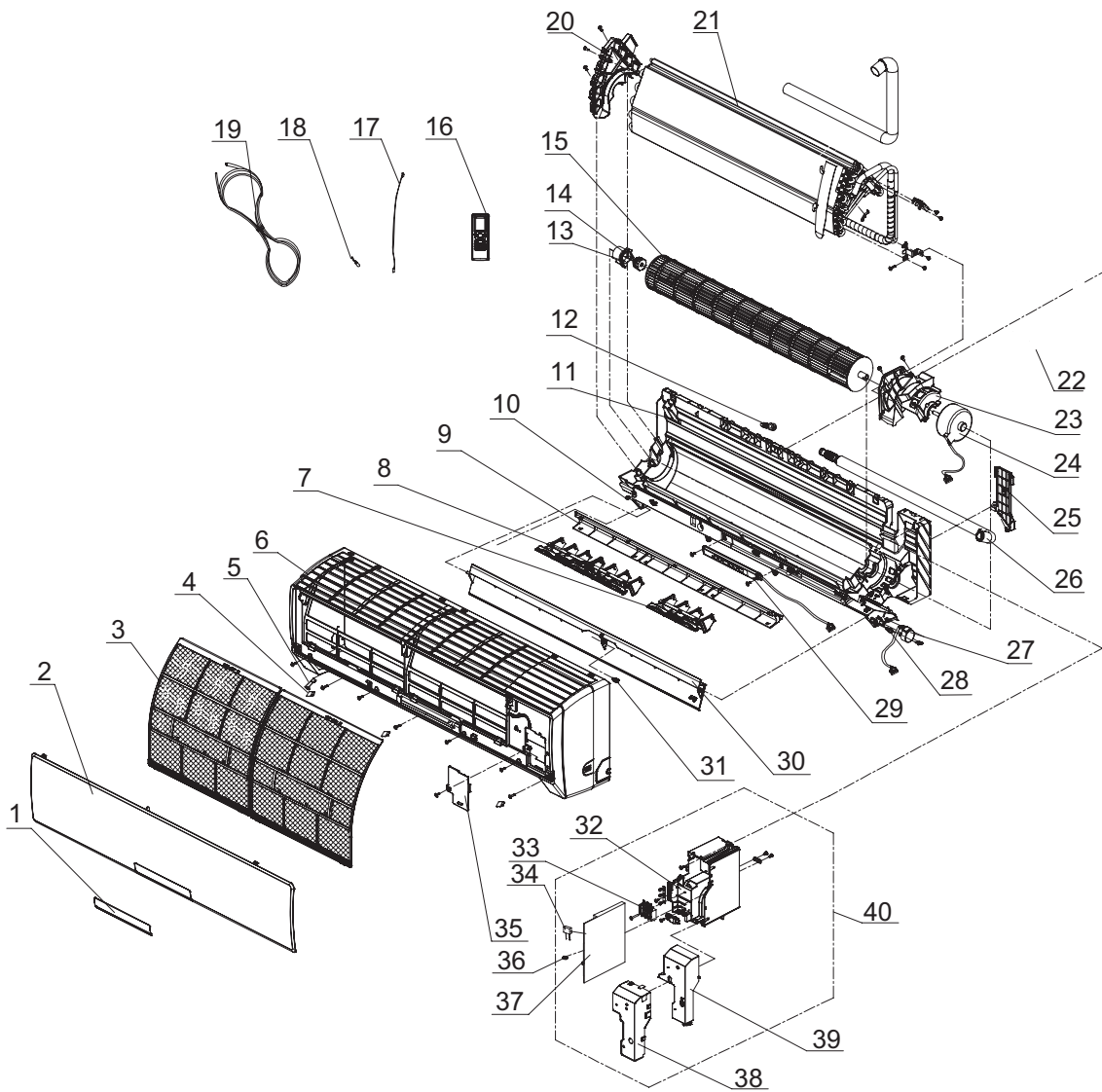

Exploded Views and Parts list

No.	Description	Part Code		Qty
		GWH(18)MC-K3DNA3B/I	GWH(18)MC-K3DNA2B/I	
		Product Code		
		CB171N0360	CB181N02900	
1	Receiver Window	22432173	22432173	1
2	Front Panel Assy	20012260	20012142S	1
3	Filter Sub-Assy	1112208901	1112208901	1
4	Screw Cover	24252016	24252016	1
5	Baffle Plate	26112228	26112228	1
6	Front Case Sub-Assy	20012288	20012288	1
7	Air Louver 2	10512117	10512117	1
8	Air Louver 1	10512116	10512116	1
9	Helicoid tongue	26112238	26112238	1
10	Left Axile Bush	10512037	10512037	1
11	Rear Case assy	12312214	12312214	1
12	Rubber Plug (Water Tray)	76712012	76712012	1
13	Ring of Bearing	26152022	26152022	1
14	O-Gasket sub-assy of Bearing	76512051	76512051	1
15	Cross Flow Fan	10352019	10352019	1
16	Remote Controller	30510049	305100492	1
17	Tube Sensor	390000591	390000591	1
18	Ambient Temperature Sensor	390000453	390000453	1
19	Connecting Cable	400204056	400204056	0
20	Evaporator Support	24212100	24212100	1
21	Evaporator Assy	0100239801	0100239801	1
22	Wall Mounting Frame	01252218	01252218	1
23	Motor Press Plate	26112178	26112178	1
24	Fan Motor	15012116	15012116	1
25	Pipe Clamp	26112164	26112164	1
26	Drainage hose	05230014	05230014	1
27	Step Motor	15012086	15012086	1
28	Crank	10582070	10582070	1
29	Display Board	30565038	30565056	1
30	Guide Louver	10512115	10512115	1
31	Axile Bush	10542008	10542008	1
32	Electric Box	2011210801	2011210801	1
33	Terminal Board	42011233	42011233	1
34	Capacitor CBB61	33010043	33010043	1
35	Electric Box Cover2	20112081	20112081	1
36	Jumper	4202300109	4202300109	1
37	Main Board	30138649	30138649	1
38	Shield cover of Electric Box	01592092	01592092	1
39	Electric Box Cover1	20122128	20122128	1
40	Electric Box Assy	2020210511	20202908	1

The data above are subject to change without notice.

No.	Description	Part Code		Qty
		GWH(18)MC-K3DNC5B/I		
		CB179N01200		
1	Receiver Window	22432194		1
2	Front Panel Assy	20012583		1
3	Filter Sub-Assy	1112208901		2
4	Screw Cover	24252016		3
5	Baffle Plate	26112228		1
6	Front Case Sub-assy	20012766		1
7	Air Louver 2	10512117		1
8	Air Louver 1	10512116		1
9	Helicoid Tongue	26112238		1
10	Left Axile Bush	10512037		1
11	Rear Case assy	12312214		1
12	Rubber Plug (Water Tray)	76712012		1
13	Ring of Bearing	26152022		1
14	O-Gasket sub-assy of Bearing	76512051		1
15	Cross Flow Fan	10352019		1
16	Remote Controller	305100492		1
17	Tube Sensor	390000591		1
18	Ambient Temperature Sensor	390000453		1
19	Connecting Cable	400204056		0
20	Evaporator Support	24212100		1
21	Evaporator Assy	0100239801		1
22	Wall Mounting Frame	01252218		1
23	Motor Press Plate	26112178		1
24	Fan Motor	15012116		1
25	Pipe Clamp	26112164		1
26	Drainage Hose	05230014		1
27	Step Motor	15012086		1
28	Crank	10582070		1
29	Display Board	3056504301		1
30	Guide Louver	10512115		1
31	Axile Bush	10542008		1
32	Electric Box	2011210801		1
33	Terminal Board	42011233		1
34	Capacitor CBB61	33010043		1
35	Electric Box Cover2	20112081		1
36	Jumper	4202300109		1
37	Main Board	30138649		1
38	Shield Cover of Electric Box	01592092		1
39	Electric Box Cover1	20122128		1
40	Electric Box Assy	2020210514		1

The data above are subject to change without notice.

Model: GWH(07)MA-K3DNB8B/II(Cold plasma) GWH(09)MA-K3DNB8B/II(Cold plasma)

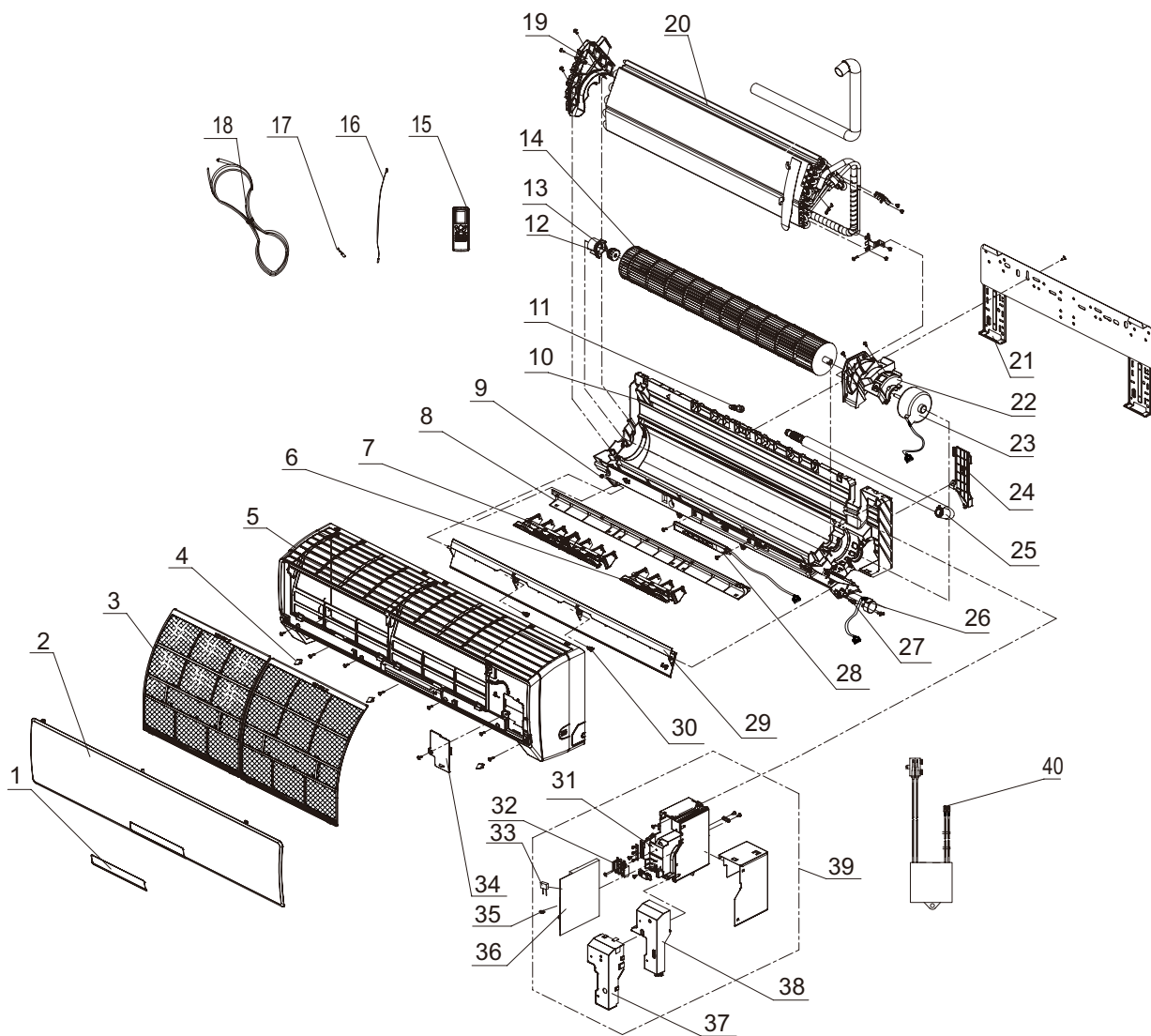

No.	Description	Part Code		Qty
		GWH(07)MA-K3DNB8B/I(Cold plasma)	GWH(09)MA-K3DNB8B/I(Cold plasma)	
		Product Code		
		CB174N02100	CB174N01901	
1	Receiver Window	/	/	/
2	Front Panel G1	2001232609	2001232609	1
3	Filter Sub-Assy	11122081	11122081	2
4	Screw Cover	24252016	24252016	3
5	Front Case	20012120C	20012120C	1
6	Air Louver 2	10512114	10512114	1
7	Air Louver 1	10512113	10512113	1
8	Helicoid Tongue	26112162	26112162	1
9	Axile Bush	10542704	10542704	1
10	Rear Case assy	2220210101	2220210101	1
11	Rubber Plug (Water Tray)	76712012	76712012	1
12	Ring of Bearing	26152022	26152022	1
13	O-Gasket sub-assy of Bearing	76512051	76512051	1
14	Cross Flow Fan	10352018	10352018	1
15	Remote Controller	305100492	305100492	1
16	Tube Sensor	390000591	390000591	1
17	Ambient Temperature Sensor	390000453	390000453	1
18	Connecting Cable	400204056	400204056	0
19	Evaporator Support	24212090	24212090	1
20	Evaporator Assy	0100274301	0100274301	1
21	Wall Mounting Frame	01252015	01252015	1
22	Motor Press Plate	26112160	26112160	1
23	Fan Motor	15012115	15012115	1
24	Pipe Clamp	26112164	26112164	1
25	Drainage Hose	0523001406	0523001406	1
26	Step Motor	1521210801	1521210801	1
27	Crank	10582070	10582070	1
28	Display Board	30565007	30565007	1
29	Guide Louver	10512111	10512111	1
30	Axile Bush	10542008	10542008	1
31	Electric Box	2011210501	2011210501	1
32	Terminal Board	42011233	42011233	1
33	Capacitor CBB61	33010002	33010002	1
34	Electric Box Cover2	20122075	20122075	1
35	Jumper	4202300101	4202300101	1
36	Main Board	30138656	30138656	1
37	Shield Cover of Electric Box Sub-assy	0159207301	0159207301	1
38	Electric Box Cover1	20122103	20122103	1
39	Electric Box Assy	2020209924	2020209924	1
40	Cold Plasma Generator Sub-assy	11140009	11140009	1

The data above are subject to change without notice.

Model: GWH(12)MB-K3DNB8B/I(Cold plasma)

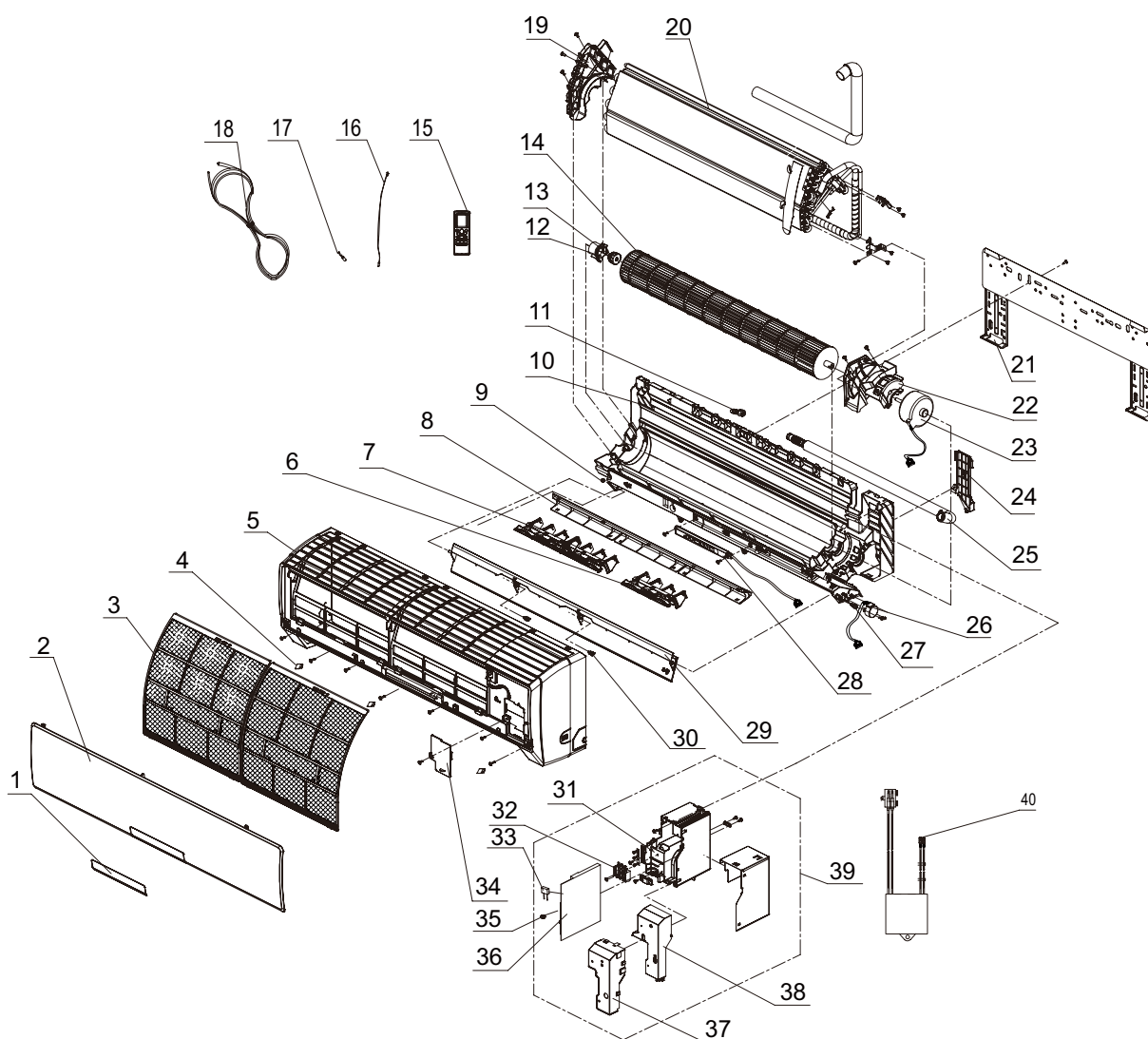

No.	Description	Part Code		Qty
		GWH(12)MB-K3DNB8B/I(Cold plasma)		
		Product Code	CB174N02001	
1	Receiver Window	/		/
2	Front Panel 11	2001220409		1
3	Filter Sub-Assy	1112220403		2
4	Screw Cover	24252016		1
5	Front Case Sub-assy	2001213908		1
6	Air Louver 2	10512155		1
7	Air Louver 1	10512156		1
8	Helicoid Tongue	26112163		1
9	Left Axile Bush	10512037		1
10	Rear Case assy	2220210301		1
11	Rubber Plug (Water Tray)	76712012		1
12	Ring of Bearing	26152022		1
13	O-Gasket sub-assy of Bearing	76512051		1
14	Cross Flow Fan	10352017		1
15	Remote Controller	305100492		1
16	Tube Sensor	390000591		1
17	Ambient Temperature Sensor	390000453		1
18	Connecting Cable	400204056		0
19	Evaporator Support	24212091		1
20	Evaporator Assy	0100274402		1
21	Wall Mounting Frame	01252021		1
22	Motor Press Plate	26112161		1
23	Fan Motor	150120874		1
24	Pipe Clamp	26112164		1
25	Drainage Hose	0523001401		1
26	Step Motor	1521210801		1
27	Crank	10582070		1
28	Display Board	30565007		1
29	Guide Louver	10512157		1
30	Axile Bush	10542008		1
31	Electric Box	2011210501		1
32	Terminal Board	42011233		1
33	Capacitor CBB61	33010002		1
34	Electric Box Cover2	20122075		1
35	Jumper	4202300105		1
36	Main Board	30138656		1
37	Shield Cover of Electric Box Sub-assy	0159207301		1
38	Electric Box Cover1	20122103		1
39	Electric Box Assy	2020210005		1
40	Cold Plasma Generator Sub-assy	11140009		1

The data above are subject to change without notice.

Model: GWH(18)MC-K3DNB8B/I(Cold plasma)

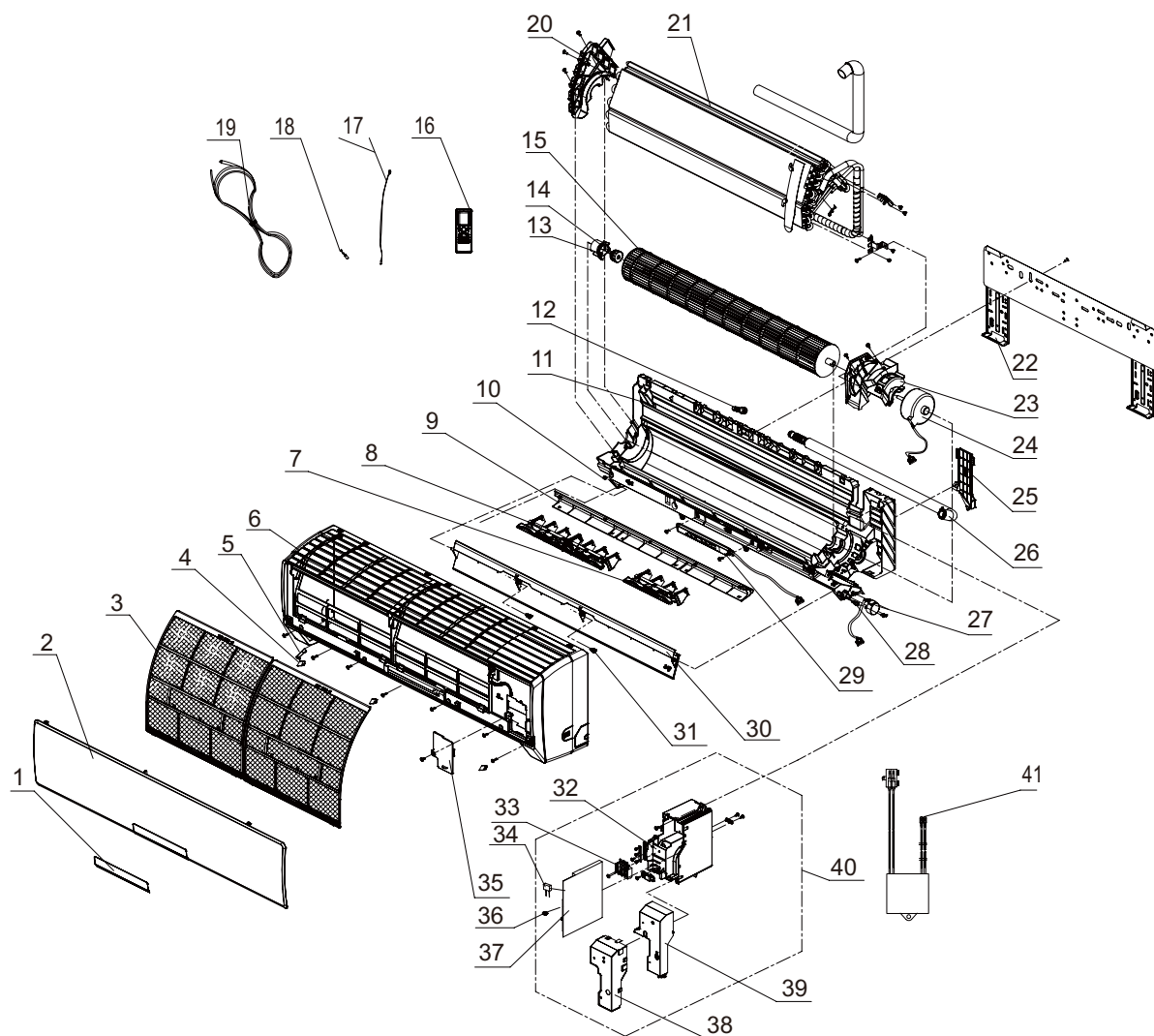

No.	Description	Part Code		Qty
		GWH(18)MC-K3DNB8B/I/(Cold plasma)		
		Product Code	CB174N02200	
1	Receiver Window	/	/	/
2	Front Panel B8	20012485		1
3	Filter Sub-Assy	1112208901		2
4	Screw Cover	24252016		3
5	Baffle Plate	26112228		1
6	Front Case Sub-assy	20012288		1
7	Air Louver 2	10512117		1
8	Air Louver 1	10512116		1
9	Helicoid Tongue	26112238		1
10	Left Axile Bush	10512037		1
11	Rear Case assy	12312214		1
12	Rubber Plug (Water Tray)	76712012		1
13	Ring of Bearing	26152022		1
14	O-Gasket sub-assy of Bearing	76512051		1
15	Cross Flow Fan	10352019		1
16	Remote Controller	305100492		1
17	Tube Sensor	390000591		1
18	Ambient Temperature Sensor	390000453		1
19	Connecting Cable	400204056		0
20	Evaporator Support	24212100		1
21	Evaporator Assy	0100239802		1
22	Wall Mounting Frame	01252218		1
23	Motor Press Plate	26112178		1
24	Fan Motor	15012116		1
25	Pipe Clamp	26112164		1
26	Drainage Hose	05230014		1
27	Step Motor	15012086		1
28	Crank	10582070		1
29	Display Board	30565038		1
30	Guide Louver	10512115		1
31	Axile Bush	10542008		1
32	Electric Box	2011210801		1
33	Terminal Board	42011233		1
34	Capacitor CBB61	33010043		1
35	Electric Box Cover2	20112081		1
36	Jumper	4202300109		1
37	Main Board	30138650		1
38	Lower Shield of Electric Box	01592091		1
39	Electric Box Cover1	20122128		1
40	Electric Box Assy	2020210515		1
41	Cold Plasma Generator Sub-assy	11140009		1

The data above are subject to change without notice.

9. Troubleshooting

9.1 Malfunction Display

Malfunction indicator of indoor unit (indicator: off for 3s and blink for n times; blink means on 0.5s and off 0.5s.)

1. Malfunction display requirement

When there are several malfunctions, they will be displayed circularly.

2. Malfunction display method

(1) Hardware malfunction: immediate display; refer to “malfunction display table”;

(2) Operation state: immediate display; refer to “malfunction display table”;

(3) Other malfunctions: it is displayed after the compressor stops for 200s; refer to “malfunction display table” .

Note: when the compressor is restarted, the malfunction display delay time (200s) is cleared.

(4) When the unit is under limit frequency or frequency drop state, the display can be controlled via remote controller.

3. Malfunction display control

The indicator lamp and dual 8 nixie tube displays shall be synchronized. That is when the indicator lamp blinks, the dual 8 nixie tube displays the corresponding malfunction code.

4. Display control via remote controller

Enter display control: press light button successively for 4 times within 3s to display the corresponding malfunction code;

Exit display control: pressing light button successively for 4 times within 3s or after display is shown for 5min, the display will terminate.

Malfunction	Definition of malfunction	Dual 8 nixie tube	Indicator display		
			Operation indicator	Cooling indicator	Heating indicator
Cross zero detection circuit malfunction (indoor)	Hardware malfunction	U8	Blink 17 times		
Jumper cap malfunction protection (indoor)	Hardware malfunction	C5	Blink 15 times		
No indoor unit feedback	Hardware malfunction	H6	Blink 11 times		
Short & open circuit of indoor ambient temperature sensor	Hardware malfunction	F1		Blink once	
Short & open circuit of indoor evaporator temperature sensor	Hardware malfunction	F2		Blink twice	
Communication malfunction	Hardware malfunction	E6	Blink 6 times		

Display under test state

Dual 8 nixie tube display: minimum cooling (heating)-P0; middle cooling (heating)-P3

Nominal cooling (heating) –P1; maximum cooling (heating) –P2;

Corresponding indicator lamp will be on for 0.3s and off for 0.3s

9.2 Troubleshooting

9.2.1 F1/F2 malfunction

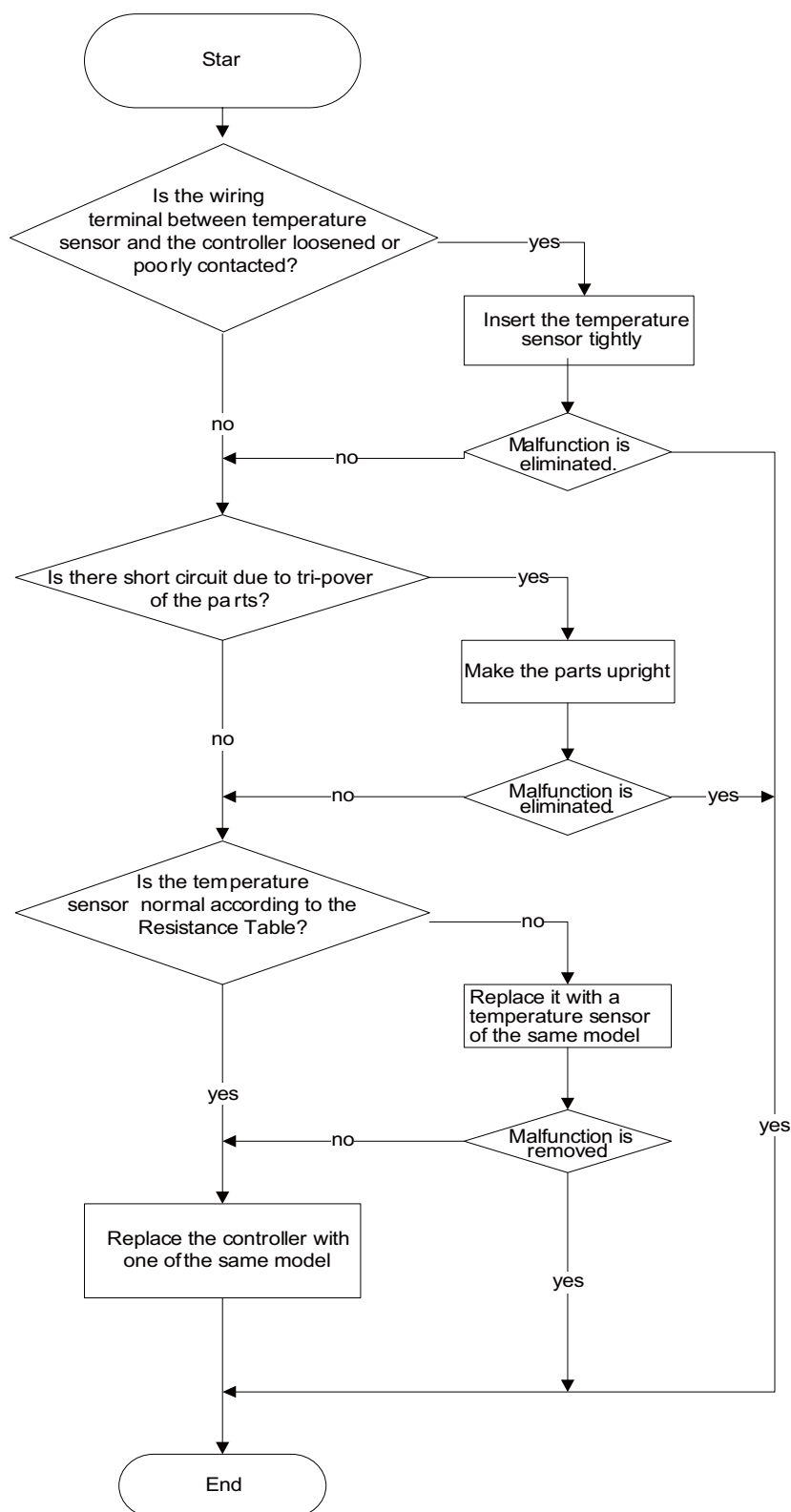

9.2.2 H6 malfunction

Possible causes: 1. Fan motor is locked; 2. The feedback terminal of PG motor is not connected tightly; 3. The control terminal of PG motor is not connected tightly; 4. Motor is damaged; 5. Malfunction of the rotation speed detection circuit of the mainboard. See the flow chart below:

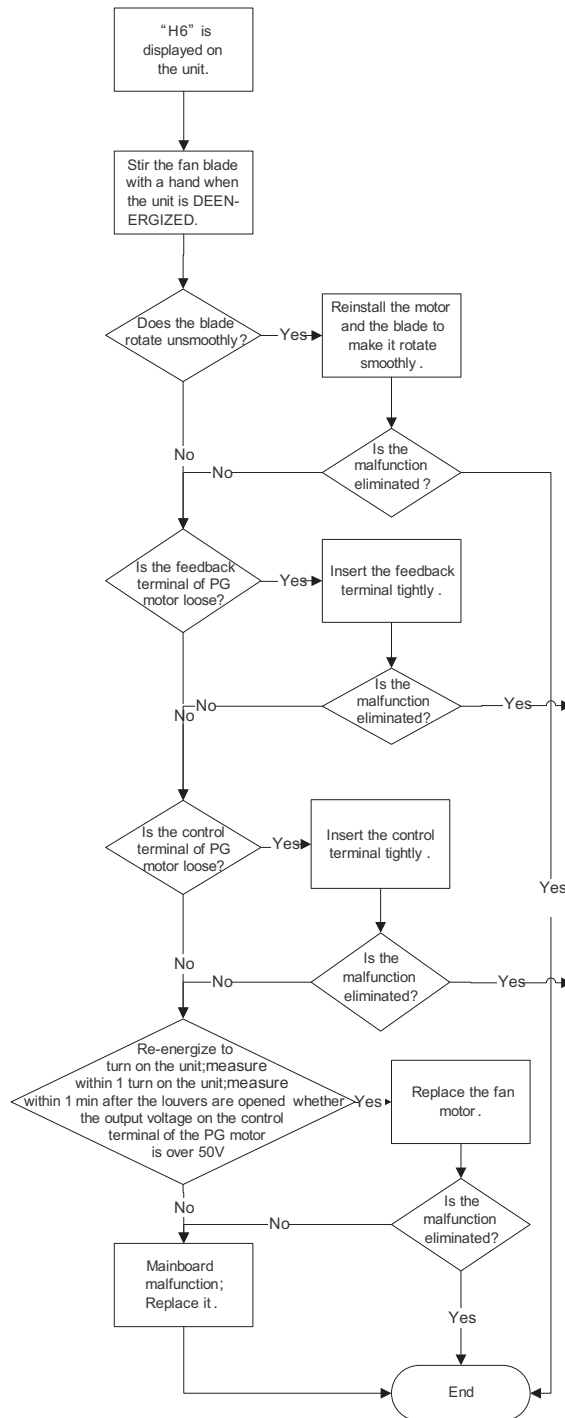

9.2.3 C5 malfunction

Possible causes: 1. There is no jumper cap on the controller; 2. Jumper cap is not inserted properly and tightly; 3. Jumper cap is damaged; 4. Controller is damaged. See the flow chart below:

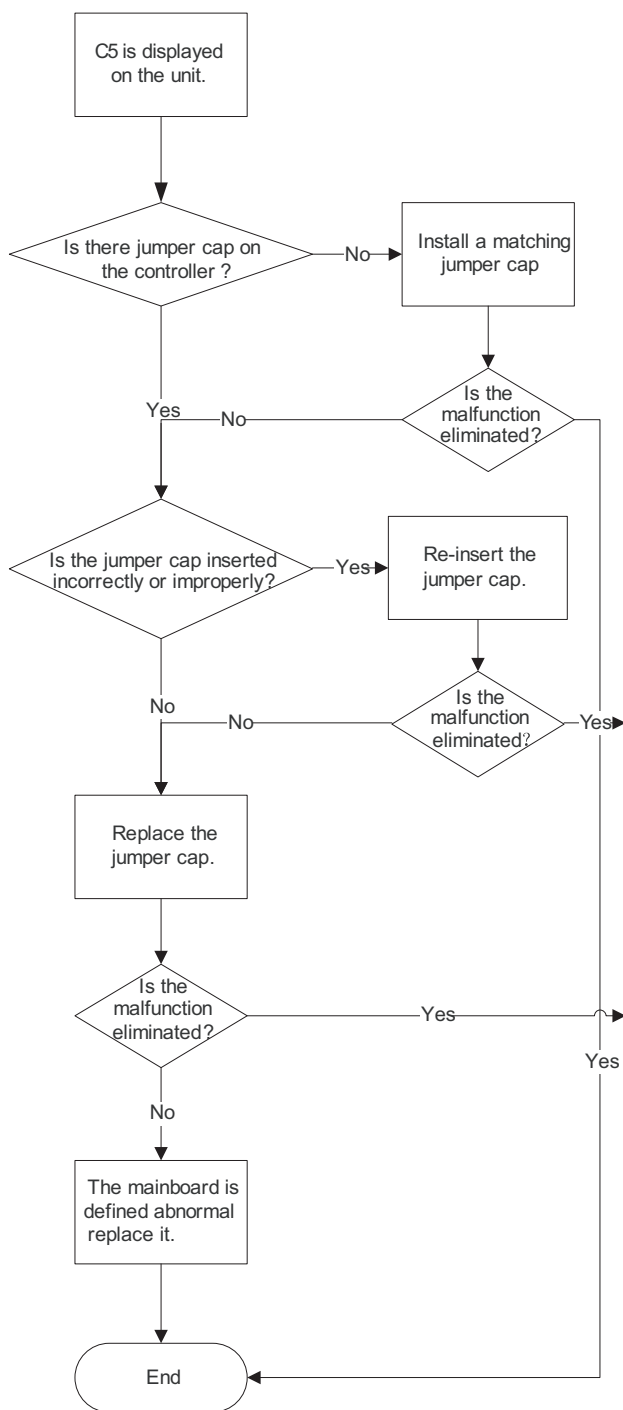

9.2.4 U8 malfunction

Possible causes; 1.The controller diagnoses incorrectly due to instant energization after de-energized while the capacitor discharges slowly; 2.Malfunction of the zero-cross detection circuit of the mainboard. See the flow chart below:

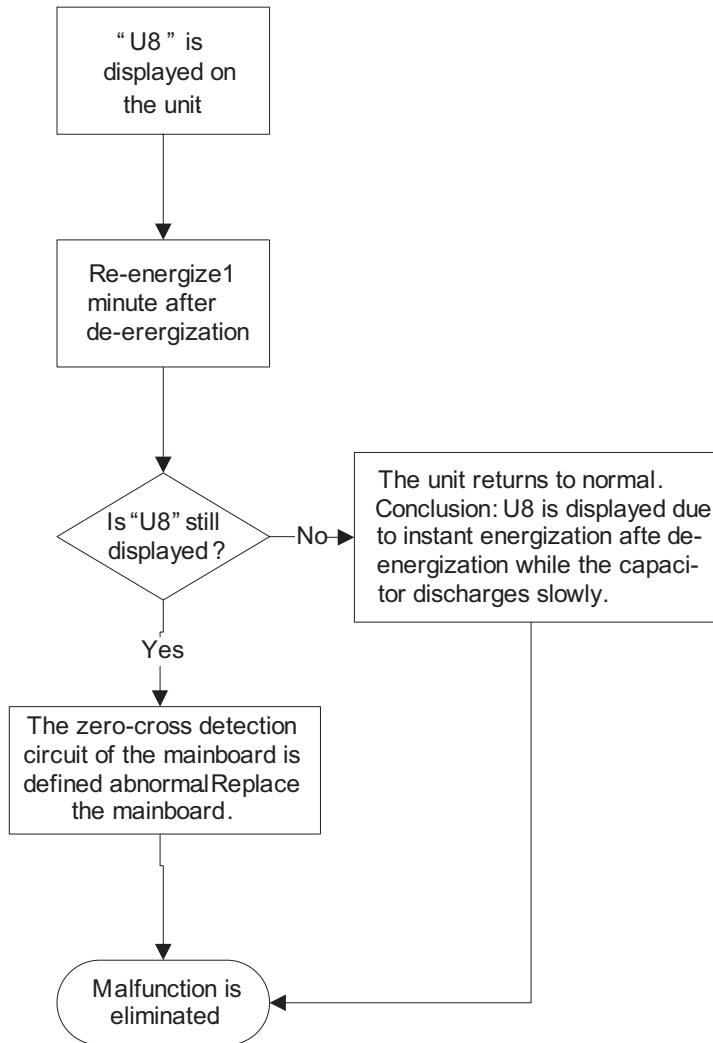

9.2.5 E6 malfunction

Inspection

- Check if connection wire between indoor and outdoor units and wire inside the unit are connected well.
- Check if mainboard of indoor or outdoor unit is damaged

Flowchart

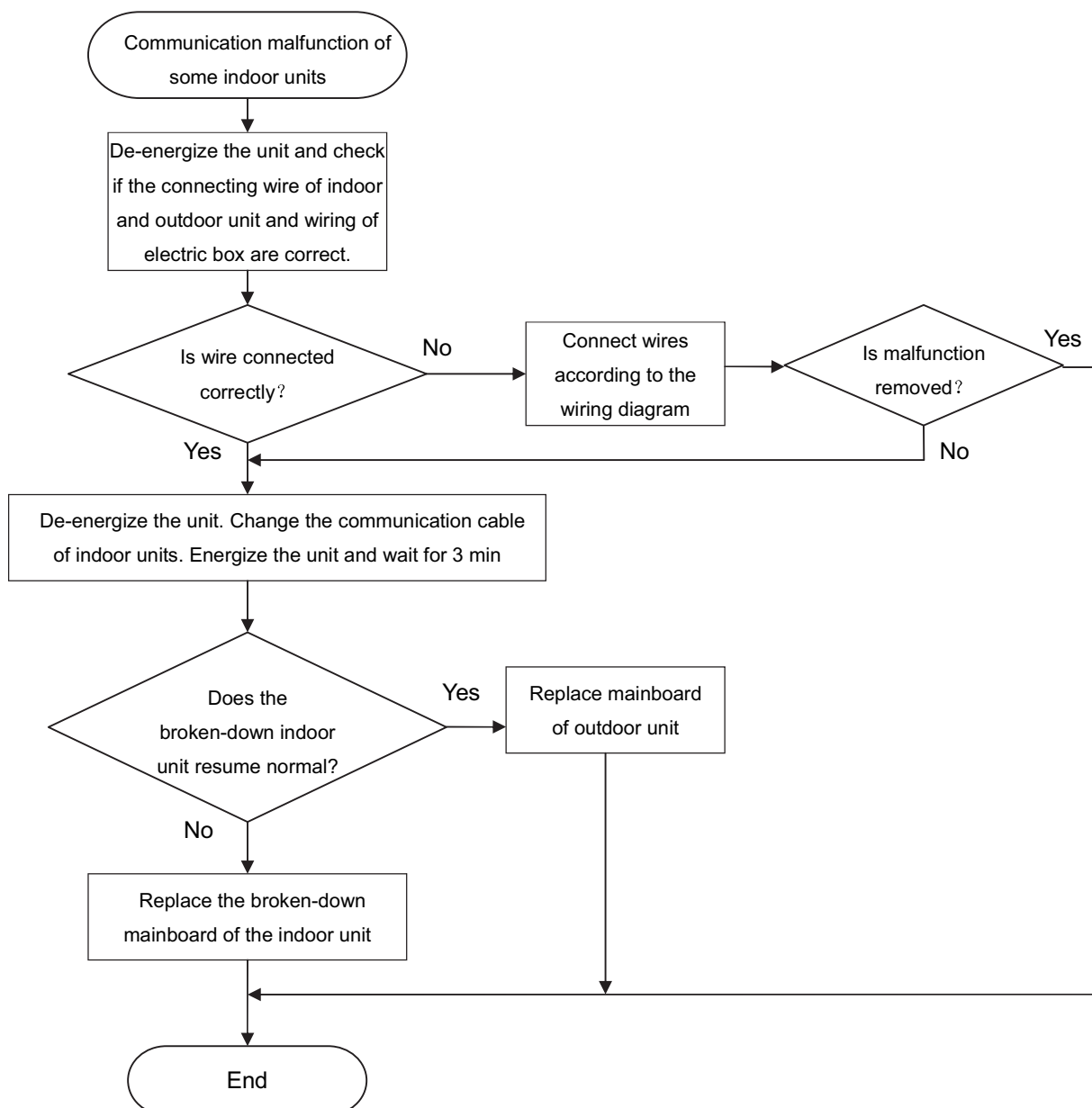

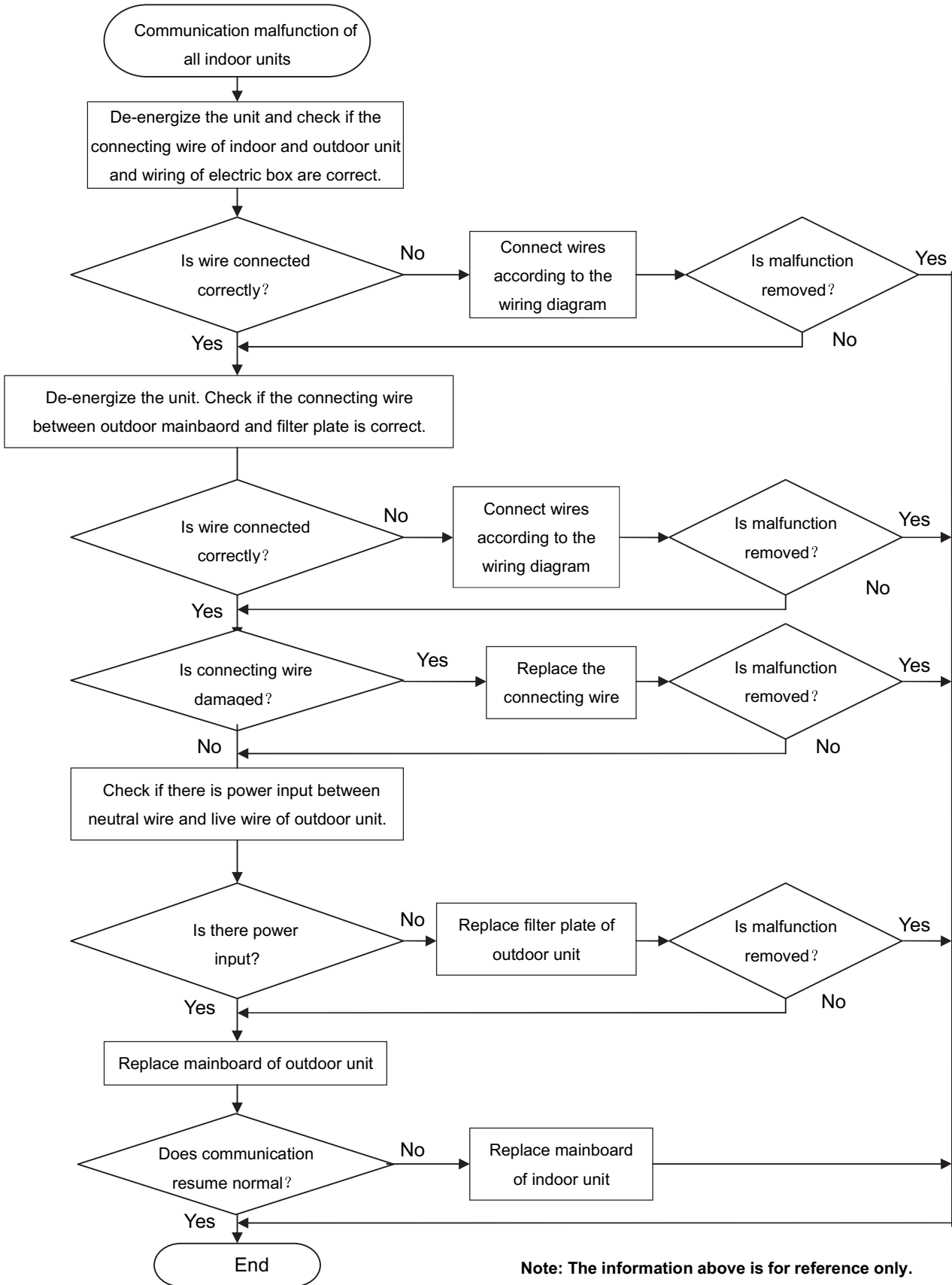

Note: The information above is for reference only.

10. Removal Procedure

Warning Be sure to wait for a minimum of 10 minutes after turning off all power supplies before disassembly.

Note: Take A2 front Panel for Example.

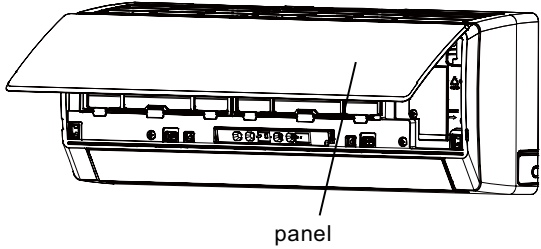
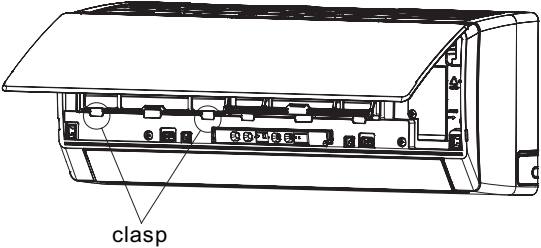
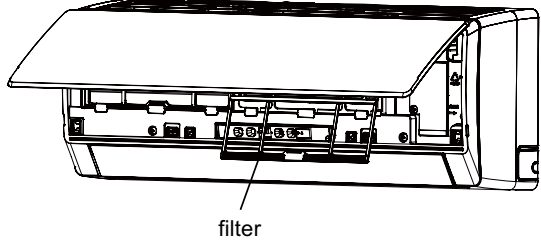
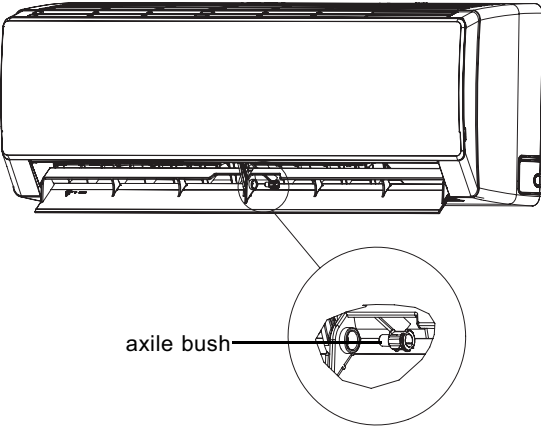
Step	Procedure	
1.Remove the filter		
1	Open the panel.	
2	Loosen the clasp of the filter.	
3	Push the filter inward and then raise it to remove it.	
2.Remove horizontal louver		
1	Remove axle bush of horizontal louver.	

Removal Procedure

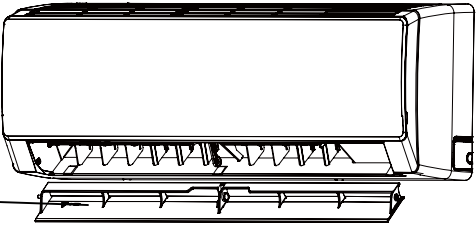
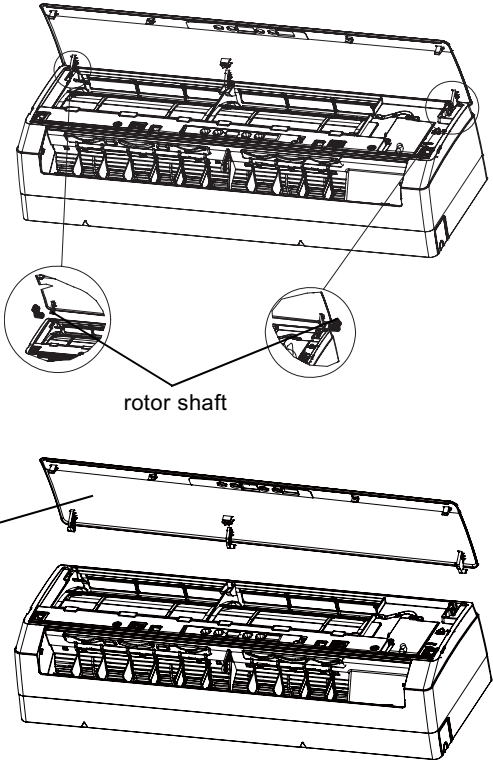
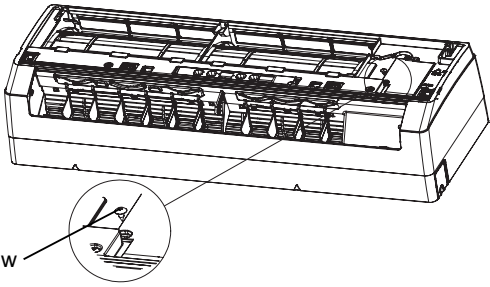
Step	Procedure	
2	Bend the horizontal louver slightly to remove it.	 <p data-bbox="818 533 911 591">horizontal louver</p>
3.Remove front panel		
1	Slide the rotor shaft out of the groove. Remove the front panel.	 <p data-bbox="1038 1066 1147 1093">rotor shaft</p> <p data-bbox="831 1189 903 1247">front panel</p>
4.Remove electric box cover 2		
1	Remove the screws fixing the electric box cover 2.	 <p data-bbox="874 1823 938 1850">screw</p>

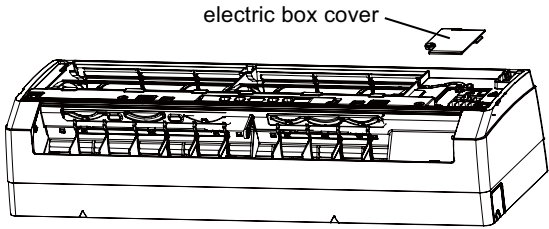
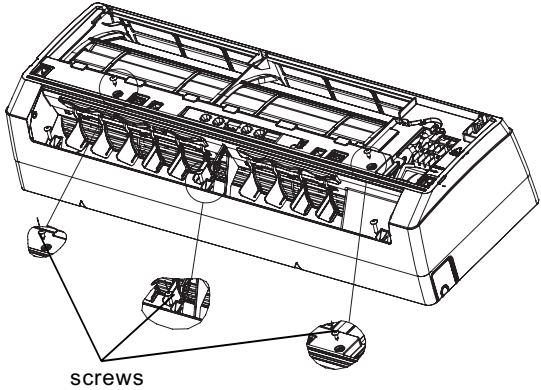
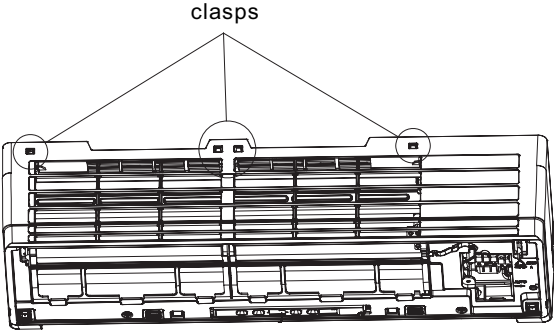
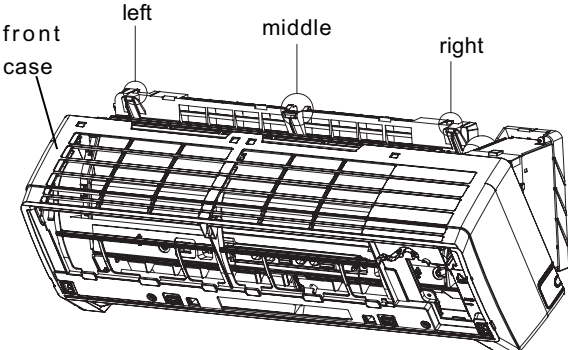
Step	Procedure	
2	Remove the electric box cover2.	 <p>electric box cover</p>
5.Remove front case		
1	Open the screw cap on the front case. Remove the screws fixing the front case.	 <p>screws</p>
2	Loosen the left, middle and right clasps.	 <p>clasps</p>
3	Remove the front case.	 <p>front case</p> <p>left</p> <p>middle</p> <p>right</p>

Removal Procedure

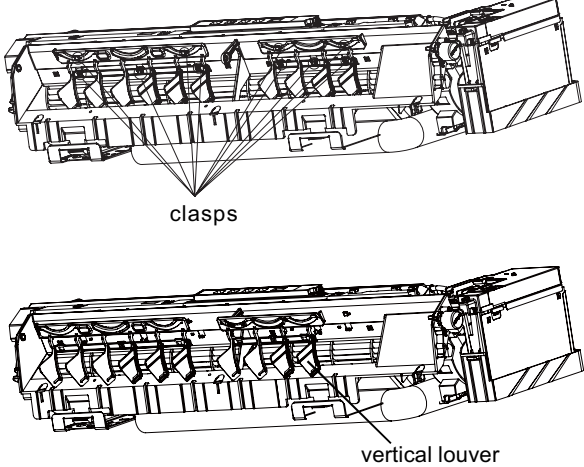
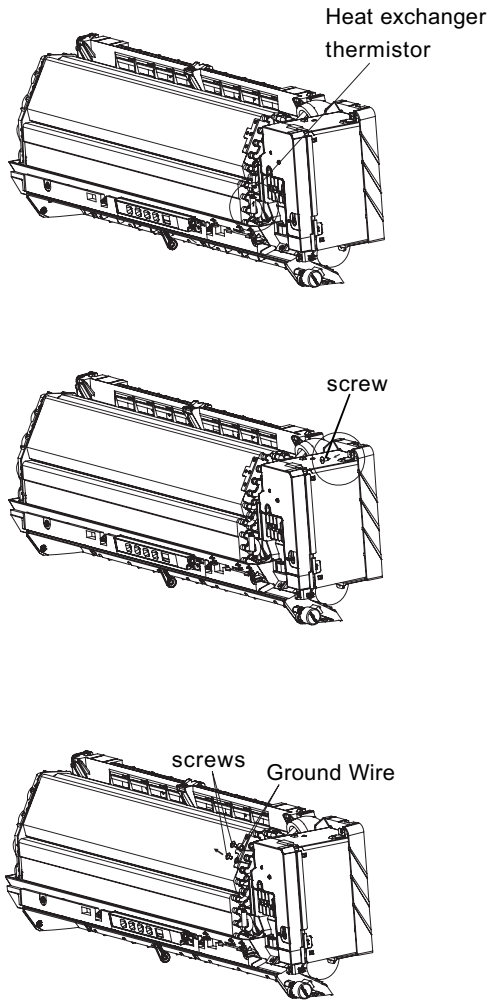
Step	Procedure	
6.Remove vertical louver	<p>1 Loosen the clasps connecting vertical louver with bottom case.</p> <p>2 Remove the vertical louver.</p>	
7.Remove electric box	<p>1 Disconnect the indoor pipe temperature sensor.</p> <p>2 Remove the screw of the electric box.</p> <p>3 Remove the screws at the joint of ground wire and evaporator.</p>	

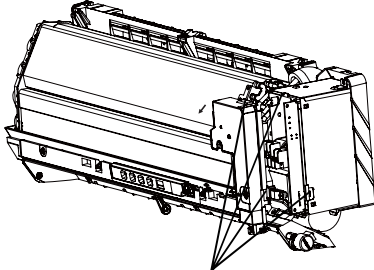
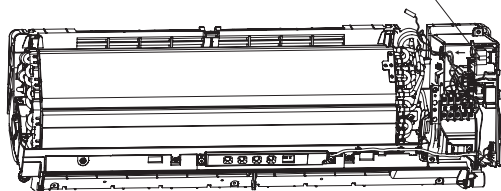
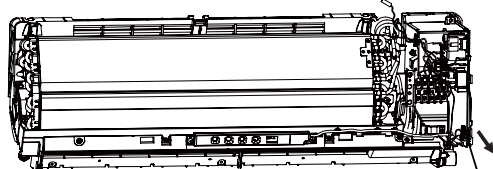
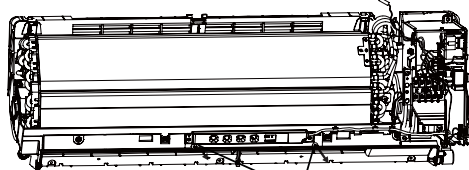
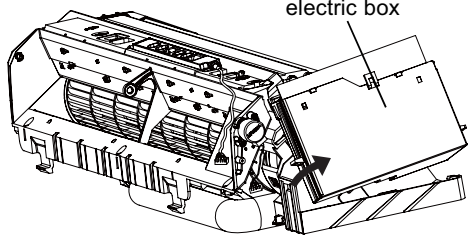
Step	Procedure	
4	Remove the clasp connecting electric box cover and electric box. Remove electric box cover.	 <p>clasp</p>
5	Disconnect the connecting wire of the motor.	 <p>fan motor signal wire</p>
6	Disconnect the connecting wire of the step motor.	 <p>connector of step motor</p>
7	Remove the screw fixing the display. Remove the display.	 <p>Screw</p>
8	Remove the electric box.	 <p>electric box</p>

Removal Procedure

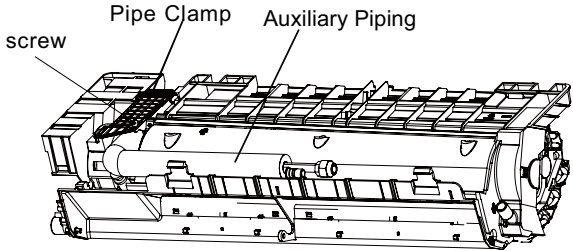
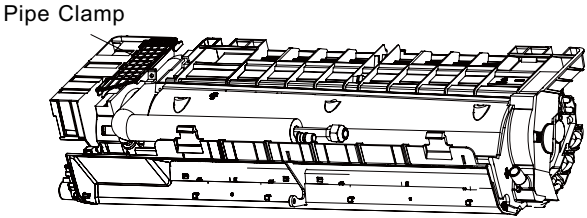
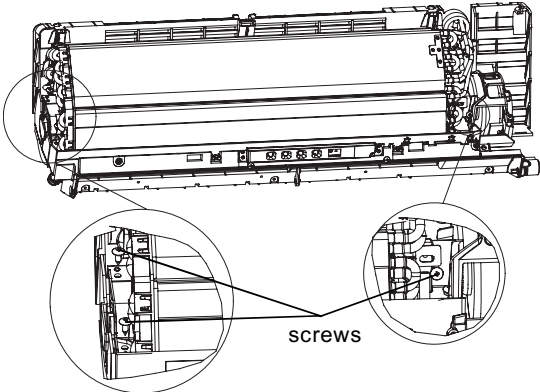
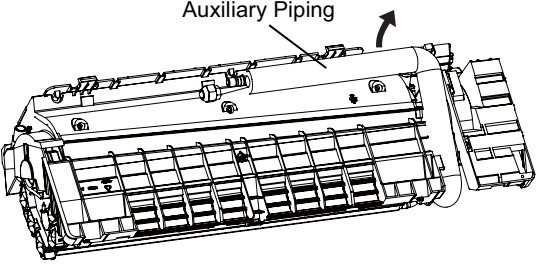
Step	Procedure
8.Remove press plate of connecting pipe	
1	<p>Remove the screw fixing the press plate of the connecting pipe.</p> 
2	<p>Remove the press plate of the connecting pipe.</p> 
9.Remove the evaporator	
1	<p>Remove the 3 screws at the joint of the evaporator and bottom case.</p> 
2	<p>Adjust the pipe of evaporator.</p> 

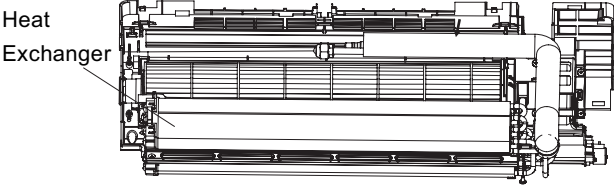
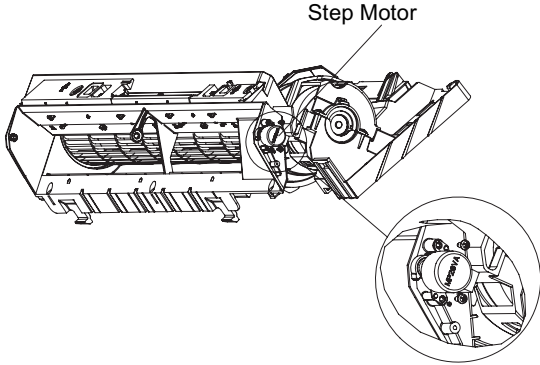
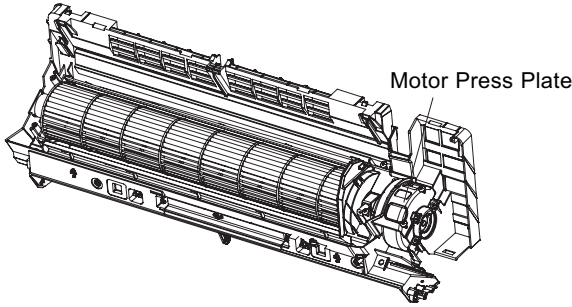
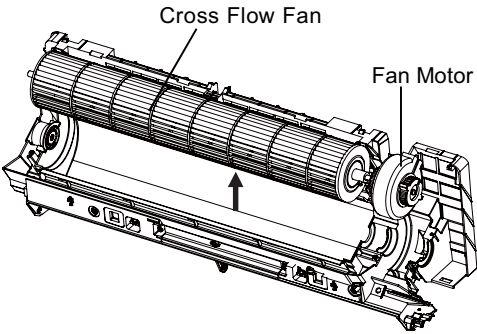
Step	Procedure	
3	Remove the evaporator.	
10.Remove cross flow blade and motor		
1	Remove the screws fixing the step motor. Remove the step motor.	
2	Remove the screws fixing the press plate of the motor. Remove the motor.	
3	Remove cross flow blade and motor.	

Removal Procedure

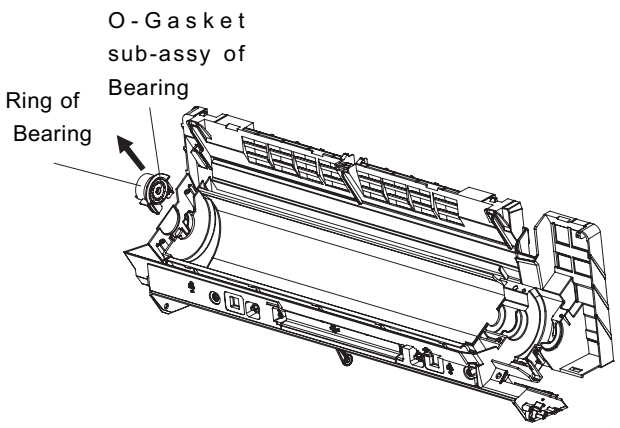
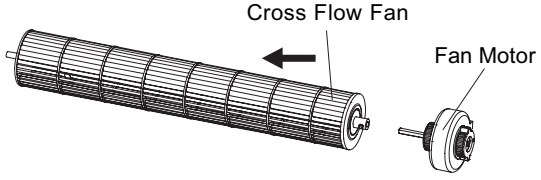
Step	Procedure	
4	Remove ring of bearing.	 <p>O - Gasket sub-assy of Bearing</p> <p>Ring of Bearing</p>
5	Remove the screws at the joint of cross flow blade and motor. Remove the motor.	 <p>Cross Flow Fan</p> <p>Fan Motor</p>



GREE ELECTRIC APPLIANCES,INC.OF ZHUHAI

Add:Jinji west Rd.Qianshan Zhuhai Guangdong China

Tel:86-756-8522219 (After sale Service Dept)

Post code: 519070