



# Service Manual

---

**MODEL: GWCN28FANK1A1A  
GWHN28FANK1A1A  
(Refrigerant R22)**

**GREE ELECTRIC APPLIANCES, INC.OF ZHUHAI**

<b>Summary and Features</b> .....	1
<b>Part 1 Safety Precautions</b> .....	2
<b>Part 2 Specifications</b> .....	3
2.1 Unit Specifications.....	3
2.2 Capacity Variation Ratio According to Temperature.....	7
2.3 Operation Data.....	7
<b>Part 3 Construction Views</b> .....	8
3.1 Indoor Unit.....	8
3.2 Outdoor Unit.....	9
<b>Part 4 Refrigerant System Diagram</b> .....	9
<b>Part 5 Schematic Diagram</b> .....	10
5.1 Electrical Data.....	10
5.2 Electrical Wiring.....	11
5.3 Printed Circuit Board.....	13
<b>Part 6 Function and Control</b> .....	17
6.1 Remote Control Operations.....	17
6.2 Description of Each Control Operation.....	21
<b>Part 7 Installation Manual</b> .....	26
7.1 Notices for installation.....	26
7.2 Installation Dimension Diagram.....	28
7.3 Install Indoor Unit.....	29
7.4 Install Outdoor Unit.....	31
7.5 Check After Installation and Test Operation.....	32
7.6 Installation and Maintenance of Healthy Filter.....	33

---

<b>Part 8 Exploded Views and Parts List</b> .....	34
8.1 Indoor Unit .....	34
8.2 Outdoor Unit .....	40
<b>Part 9 Troubleshooting</b> .....	44
9.1 Precautions Before Performing Inspection or Repair.....	44
9.2 Confirmation.....	44
9.3 Judgement by Flashing LED of Indoor/Outdoor Unit.....	44
9.4 How to Check Simply the Main Part.....	48
<b>Part10 Removal Procedure</b> .....	54
10.1 Removal Procedure of Indoor Unit.....	54
10.2 Removal Procedure of Outdoor Unit.....	58

---

# Summary and Features

## Indoor Unit

GWHN28FANK1A1A/I(CA152N0450)



GWCN28FANK1A1A/I(CA152N0441)



GWCN28FANK1A1A/I(CA152N0443)

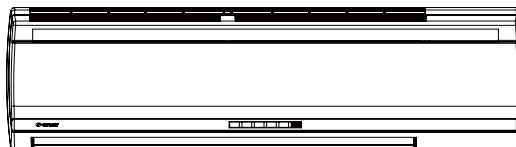

## Outdoor Unit

GWCN28FANK1A1A/O

GWHN28FANK1A1A/O

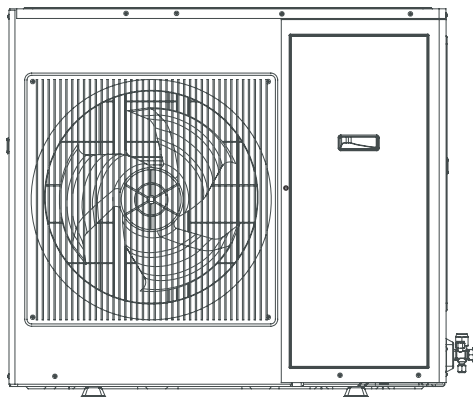

## Remote Controller

YT1F



# 1. Safety Precautions

Installing, starting up, and servicing air conditioner can be hazardous due to system pressure, electrical components, and equipment location, etc.

Only trained, qualified installers and service personnel are allowed to install, start-up, and service this equipment. Untrained personnel can perform basic maintenance functions such as cleaning coils. All other operations should be performed by trained service personnel.

When handling the equipment, observe precautions in the manual and on tags, stickers, and labels attached to the equipment. Follow all safety codes. Wear safety glasses and work gloves. Keep quenching cloth and fire extinguisher nearby when brazing.

Read the instructions thoroughly and follow all warnings or cautions in literature and attached to the unit. Consult local building codes and current editions of national as well as local electrical codes.

Recognize the following safety information:

 **Warning** Incorrect handling could result in personal injury or death.

 **Caution** Incorrect handling may result in minor injury, or damage to product or property.

- Make sure the outdoor unit is installed on a stable, level surface with no accumulation of snow, leaves, or trash beside.
- Make sure the ceiling/wall is strong enough to bear the weight of the unit.
- Make sure the noise of the outdoor unit does not disturb neighbors.
- Follow all the installation instructions to minimize the risk of damage from earthquakes, typhoons or strong winds.
- Avoid contact between refrigerant and fire as it generates poisonous gas.
- Apply specified refrigerant only. Never have it mixed with any other refrigerant. Never have air remain in the refrigerant line as it may lead to rupture and other hazards.
- Make sure no refrigerant gas is leaking out when installation is completed.
- Should there be refrigerant leakage, the density of refrigerant in the air shall in no way exceed its limited value, or it may lead to explosion.
- Keep your fingers and clothing away from any moving parts.
- Clear the site after installation. Make sure no foreign objects are left in the unit.
- Always ensure effective grounding for the unit.

---

## Warning

All electric work must be performed by a licensed technician according to local regulations and the instructions given in this manual.

- Before installing, modifying, or servicing system, main electrical disconnect switch must be in the OFF position. There may be more than 1 disconnect switch. Lock out and tag switch with a suitable warning label.
- Never supply power to the unit unless all wiring and tubing are completed, reconnected and checked.
- This system adopts highly dangerous electrical voltage. Incorrect connection or inadequate grounding can cause personal injury or death. Stick to the wiring diagram and all the instructions when wiring.
- Have the unit adequately grounded in accordance with local electrical codes.
- Have all wiring connected tightly. Loose connection may lead to overheating and a possible fire hazard.

All installation or repair work shall be performed by your dealer or a specialized subcontractor as there is the risk of fire, electric shock, explosion or injury.

---

## Caution

- Never install the unit in a place where a combustible gas might leak, or it may lead to fire or explosion.
- Make a proper provision against noise when the unit is installed at a telecommunication center or hospital.
- Provide an electric leak breaker when it is installed in a watery place.
- Never wash the unit with water.
- Handle unit transportation with care. The unit should not be carried by only one person if it is more than 20kg.
- Never touch the heat exchanger fins with bare hands.
- Never touch the compressor or refrigerant piping without wearing glove.
- Do not have the unit operate without air filter.
- Should any emergency occur, stop the unit and disconnect the power immediately.
- Properly insulate any tubing running inside the room to prevent the water from damaging the wall.

## 2. Specifications

### 2.1 Unit Specifications

Model			GWHN28FANK1A1A	
Product Code			CA15200450	
Rated Voltage	V~		220-240	
Rated Frequency	Hz		50	
Phases			1	
Power Supply Mode			Outdoor	
Cooling Capacity	W		8000	
Heating Capacity	W		8800	
Cooling Power Input	W		3200	
Heating Power Input	W		3100	
Cooling Power Current	A		14.84	
Heating Power Current	A		14.38	
Rated Input	W		4200	
Rated Current	A		19.50	
Air Flow Volume(SH/H/M/L/SL)	m <sup>3</sup> /h		-/1200/1050/900/-	
Dehumidifying Volume	L/h		2.7	
EER	W/W		2.50	
COP	W/W		2.84	
SEER	W/W		/	
HSPF	W/W		/	
Application Area		m <sup>2</sup>	35-52	
Indoor Unit	Model of indoor unit		GWHN28FANK1A1A/I	
	Fan Type		Cross-flow	
	Diameter Length(DXL)	mm	Φ106 X 890	
	Fan Motor Cooling Speed(SH/H/M/L/SL)	r/min	-/1410/1280/1200/-	
	Fan Motor Heating Speed(SH/H/M/L/SL)	r/min	-/1410/1280/1200/-	
	Output of Fan Motor	W	30	
	Fan Motor RLA	A	0.30	
	Fan Motor Capacitor	μF	3	
	Input of Heater	W	/	
	Evaporator Form			Aluminum Fin-copper Tube
	Pipe Diameter	mm	Φ7	
	Row-fin Gap	mm	2-1.5	
	Coil Length (LXD <sub>X</sub> W)	mm	903X25.4X381	
	Swing Motor Model			MP24BA
	Output of Swing Motor	W	2	
	Fuse	A	5.00	
	Sound Pressure Level (SH/H/M/L/SL)	dB (A)		-/50/47/43/-
	Sound Power Level (SH/H/M/L/SL)	dB (A)		-/60/57/53/-
	Dimension (WXH <sub>X</sub> D)	mm		1178X326X235
	Dimension of Carton Box (L/W/H)	mm		1265X417X333
Dimension of Package(L/W/H)	mm		1268X420X348	
Net Weight	kg		17.5	
Gross Weight	kg		24	

Outdoor Unit	Model of Outdoor Unit		GWHN28FANK1A1A/O
	Compressor Manufacturer/Trademark		Hitachi Compressor Products (Guangzhou)Co., Ltd./Hitachi
	Compressor Model		303DH-50Q2
	Compressor Oil		SUNISO 4GSD
	Compressor Type		Scroll
	L.R.A.	A	85.00
	Compressor RLA	A	13.80
	Compressor Power Input	W	2980
	Overload Protector		/
	Throttling Method		Capillary
	Operation Temp	°C	16~30
	Ambient Temp (Cooling)	°C	18~43
	Ambient Temp (Heating)	°C	-7~24
	Condenser Form		Aluminum Fin-copper Tube
	Pipe Diameter	mm	Φ9.52
	Rows-fin Gap	mm	2-1.4
	Coil Length (LXDXW)	mm	968X44X813
	Fan Motor Speed	rpm	800
	Output of Fan Motor	W	82
	Fan Motor RLA	A	0.70
	Fan Motor Capacitor	μF	3.5
	Air Flow Volume of Outdoor Unit	m <sup>3</sup> /h	3600
	Fan Type		Axial-flow
	Fan Diameter	mm	482
	Defrosting Method		Automatic Defrosting
	Climate Type		T1
	Isolation		I
	Moisture Protection		IP24
	Permissible Excessive Operating Pressure for the Discharge Side	MPa	2.5
	Permissible Excessive Operating Pressure for the Suction Side	MPa	0.6
Sound Pressure Level (H/M/L)	dB (A)	60/-/-	
Sound Power Level (H/M/L)	dB (A)	70/-/-	
Dimension (WXHDXD)	mm	1018X840X412	
Dimension of Carton Box (L/W/H)	mm	1100X450X905	
Dimension of Package(L/W/H)	mm	1103X453X920	
Net Weight	kg	86	
Gross Weight	kg	91	
Refrigerant		R22	
Refrigerant Charge	kg	2.77	
Connection Pipe	Length	m	5
	Gas Additional Charge	g/m	50
	Outer Diameter Liquid Pipe	mm	Φ9.52
	Outer Diameter Gas Pipe	mm	Φ16
	Max Distance Height	m	10
	Max Distance Length	m	30

The above data is subject to change without notice. Please refer to the nameplate of the unit.

**Specifications**

Model			GWCN28FANK1A1A	GWCN28FANK1A1A	
Product Code			CA15200441	CA15200443	
Power Supply	Rated Voltage	V~	220-240	220-240	
	Rated Frequency	Hz	50	50	
	Phases		1	1	
Power Supply Mode			Outdoor	Outdoor	
Cooling Capacity		W	8000	8000	
Heating Capacity		W	/	/	
Cooling Power Input		W	3200	3200	
Heating Power Input		W	/	/	
Cooling Power Current		A	14.84	14.84	
Heating Power Current		A	/	/	
Rated Input		W	4200	4200	
Rated Current		A	19.50	19.50	
Air Flow Volume(SH/H/M/L/SL)		m <sup>3</sup> /h	-/1200/1050/900/-	-/1200/1050/900/-	
Dehumidifying Volume		L/h	2.7	2.7	
EER		W/W	2.50	2.50	
COP		W/W	/	/	
SEER		W/W	/	/	
HSPF		W/W	/	/	
Application Area		m <sup>2</sup>	35-52	35-52	
Indoor Unit	Model of indoor unit		GWCN28FANK1A1A/I	GWCN28FANK1A1A/I	
	Fan Type		Cross-flow	Cross-flow	
	Diameter Length(DXL)		mm	Φ106 X 890	Φ106 X 890
	Fan Motor Cooling Speed(SH/H/M/L/SL)		r/min	-/1410/1280/1200/-	-/1410/1280/1200/-
	Fan Motor Heating Speed(SH/H/M/L/SL)		r/min	-/1410/1280/1200/-	-/1410/1280/1200/-
	Output of Fan Motor		W	30	30
	Fan Motor RLA		A	0.30	0.30
	Fan Motor Capacitor		μF	3	3
	Input of Heater		W	/	/
	Evaporator Form			Aluminum Fin-copper Tube	Aluminum Fin-copper Tube
	Pipe Diameter		mm	Φ7	Φ7
	Row-fin Gap		mm	2-1.5	2-1.5
	Coil Length (LXDXW)		mm	903X25.4X381	903X25.4X381
	Swing Motor Model			MP24BA	MP24BA
	Output of Swing Motor		W	2	2
	Fuse		A	5.00	5.00
	Sound Pressure Level (SH/H/M/L/SL)		dB (A)	-/50/47/43/-	-/50/47/43/-
	Sound Power Level (SH/H/M/L/SL)		dB (A)	-/60/57/53/-	-/60/57/53/-
	Dimension (WXHxD)		mm	1178X326X235	1178X326X243
	Dimension of Carton Box (L/W/H)		mm	1265X417X333	1265X417X333
	Dimension of Package(L/W/H)		mm	1268X420X348	1268X420X348
Net Weight		kg	17.5	17.5	
Gross Weight		kg	24	24	



Outdoor Unit	Model of Outdoor Unit		GWCN28FANK1A1A/O	GWCN28FANK1A1A/O
	Compressor Manufacturer/Trademark		Hitachi Compressor Products (Guangzhou)Co., Ltd./Hitachi	Hitachi Compressor Products (Guangzhou)Co., Ltd./Hitachi
	Compressor Model		303DH-50Q2	303DH-50Q2
	Compressor Oil		SUNISO 4GSD	SUNISO 4GSD
	Compressor Type		Scroll	Scroll
	L.R.A.	A	85	85
	Compressor RLA	A	13.8	13.80
	Compressor Power Input	W	2980	2980
	Overload Protector		/	/
	Throttling Method		Capillary	Capillary
	Operation Temp	°C	16~30	16~30
	Ambient Temp (Cooling)	°C	18~43	18~43
	Ambient Temp (Heating)	°C	/	/
	Condenser Form		Aluminum Fin-copper Tube	Aluminum Fin-copper Tube
	Pipe Diameter	mm	Φ9.52	Φ9.52
	Rows-fin Gap	mm	2-1.4	2-1.4
	Coil Length (LXD <sub>X</sub> W)	mm	815X44X813	815X44X813
	Fan Motor Speed	rpm	800	800
	Output of Fan Motor	W	82	82
	Fan Motor RLA	A	0.7	0.70
	Fan Motor Capacitor	μF	3.5	3.5
	Air Flow Volume of Outdoor Unit	m <sup>3</sup> /h	3600	3600
	Fan Type		Axial-flow	Axial-flow
	Fan Diameter	mm	482	482
	Defrosting Method		/	/
	Climate Type		T1	T1
	Isolation		I	I
	Moisture Protection		IP24	IP24
	Permissible Excessive Operating Pressure for the Discharge Side	MPa	2.5	2.5
	Permissible Excessive Operating Pressure for the Suction Side	MPa	0.6	0.6
	Sound Pressure Level (H/M/L)	dB (A)	60/-/-	60/-/-
	Sound Power Level (H/M/L)	dB (A)	70/-/-	70/-/-
Dimension (WXHXD)	mm	1018X840X412	1018X840X412	
Dimension of Carton Box (L/W/H)	mm	1100X450X905	1100X450X905	
Dimension of Package(L/W/H)	mm	1103X453X920	1103X453X920	
Net Weight	kg	85	85	
Gross Weight	kg	90	90	
Refrigerant		R22	R22	
Refrigerant Charge	kg	2.7	2.7	
Connection Pipe	Length	m	5	5
	Gas Additional Charge	g/m	15	15
	Outer Diameter Liquid Pipe	mm	Φ9.52	Φ9.52
	Outer Diameter Gas Pipe	mm	Φ16	Φ16
	Max Distance Height	m	10	10
	Max Distance Length	m	30	30

The above data is subject to change without notice. Please refer to the nameplate of the unit.

## 2.2 Operation Characteristic Curve

cooling model

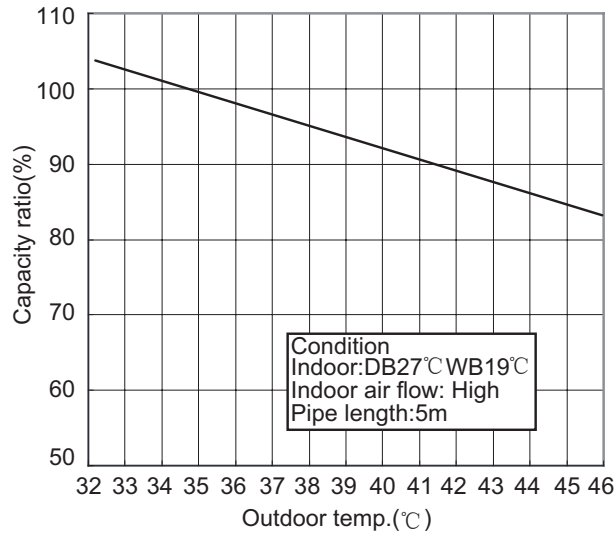

cooling and heating model

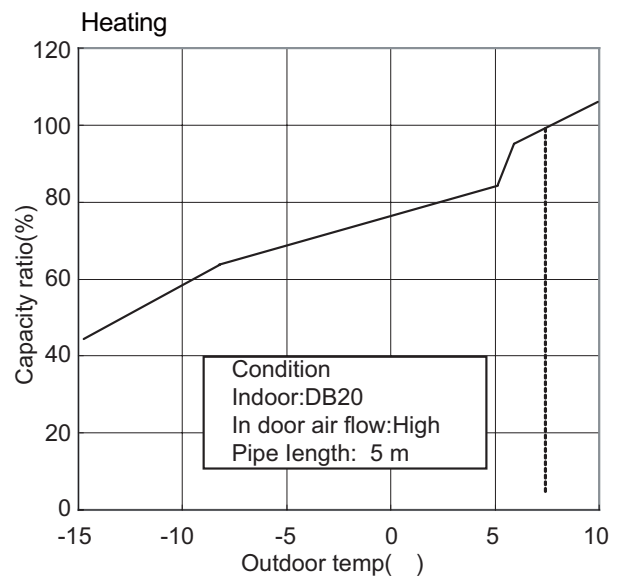
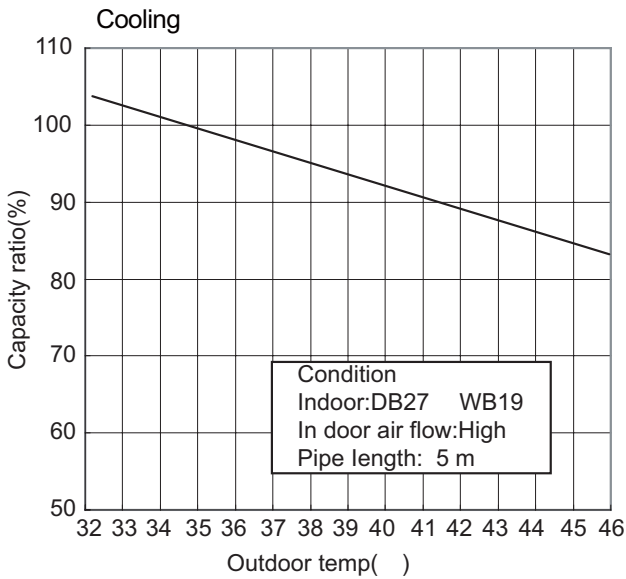

## 2.3 Operation Data

cooling model

Temperature condition (°C)		Model name	Standard pressure	Heat exchanger pipe temp.		Indoor fan mode (rpm)	Outdoor fan mode (rpm)	Compressor revolution (rps)
Indoor	Outdoor			P (MPa)	T1 (°C)			
27/19	35/24	GWCN28FANK1A1A	0.48 to 0.7	10.2 to 7.7	86.8 to 38.5	1410	800	/

cooling and heating model

Cooling

Temperature condition (°C)		Model name	Standard pressure	Heat exchanger pipe temp.		Indoor fan mode(rpm)	Outdoor fan mode(rpm)	Compressor revolution (rps)
Indoor	Outdoor		P (MPa)	T1 (°C)	T2 (°C)			
27/19	35/24	GWHN28FANK1A1A	0.48 to 0.7	10.2 to 7.7	76.9 to 38.5	1410	800	/

Heating

Temperature condition (°C)		Model name	Standard pressure	Heat exchanger pipe temp.		Indoor fan mode (rpm)	Outdoor fan mode (rpm)	Compressor revolution (rps)
Indoor	Outdoor		P (MPa)	T1 (°C)	T2 (°C)			
20/-	7/6	GWHN28FANK1A1A	2.01 to 1.85	78.2 to 37	5.8 to 1.0	1410	800	/

T1: Inlet and outlet pipe temperature of evaporator.

T2: Inlet and outlet pipe temperature of condenser.

P: Pressure of air pipe connecting indoor and outdoor units.

NOTES:

(1) Measure surface temperature of heat exchanger pipe around center of heat exchanger path U bent.

(Thermistor thermometer)

(2) Connecting piping condition : 5 m

### 3. Construction Views

#### 3.1 Indoor Unit

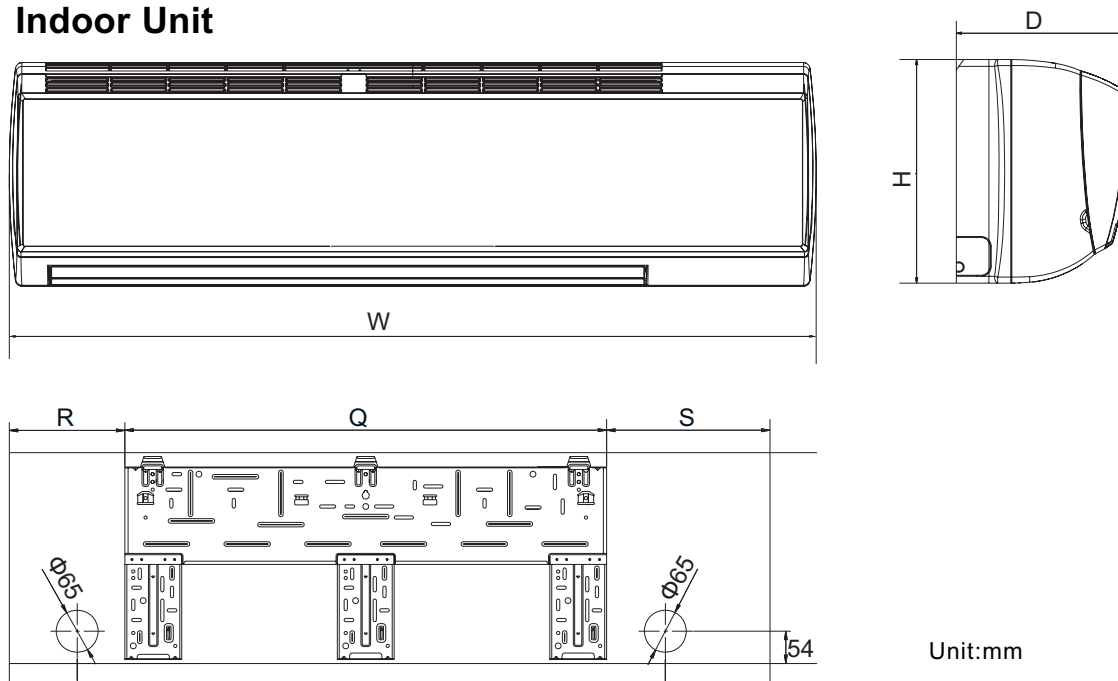

Model	W	H	D	R	Q	S
GWHN28FANK1A1A/I(CA152N0450)	1178	326	235	179	746	253
GWCN28FANK1A1A/I(CA152N0441)	1178	326	235	179	746	253
GWCN28FANK1A1A/I(CA152N0443)	1178	326	243	179	746	253

### 3.2 Outdoor Unit

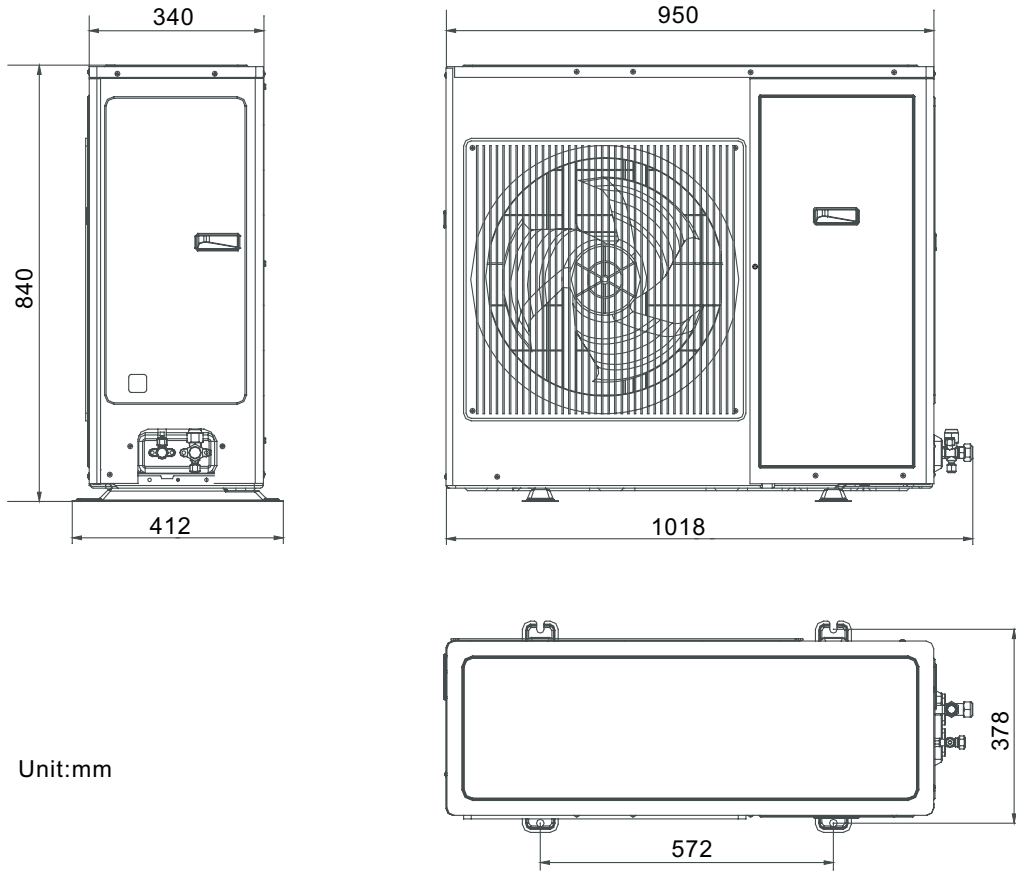

## 4. Refrigerant System Diagram

(1)Cooling Only Models

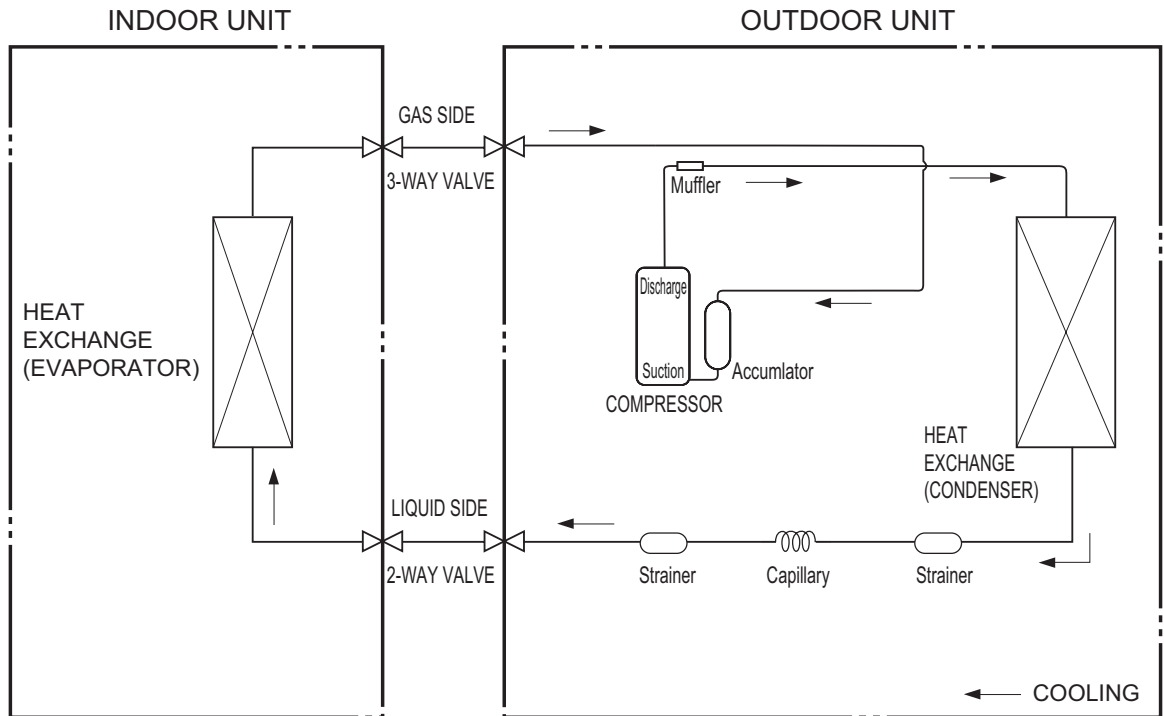

Refrigerant pipe diameter  
 Liquid : 3/8" (9.52 mm)  
 Gas : 5/8" (16 mm)

(2)Cooling & Heating Models

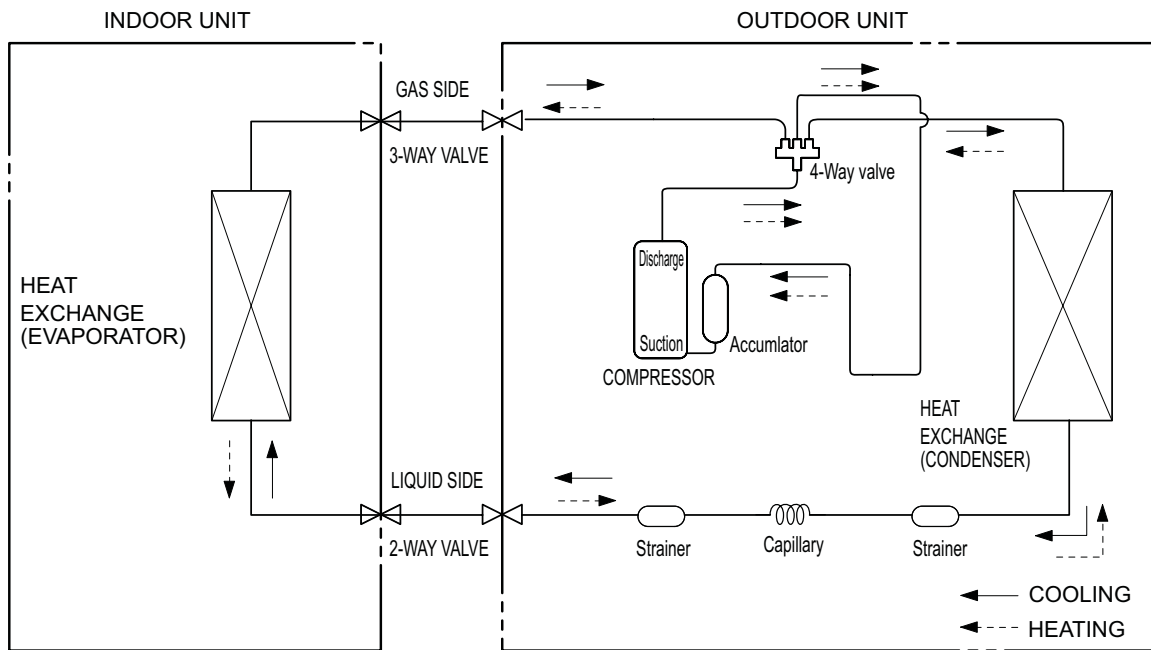

Refrigerant pipe diameter  
 Liquid : 3/8" (9.52 mm)  
 Gas : 5/8" (16 mm)

## 5. Schematic Diagram

### 5.1 Electrical Data

Meaning of marks

● Indoor Unit

Symbol	Color symbol	Symbol	Color symbol
BU	BLUE	BN	BROWN
YE	YELLOW	BK	BLACK
RD	RED	YEGN	YELLOW GREEN
		⊕	PROTECTIVE EARTH

● Outdoor Unit

Symbol	Parts name	Symbol	Color symbol
COMP	COMPRESSOR	BU	BLUE
YEGN	YELLOW GREEN	YE	YELLOW
⊕	PROTECTIVE EARTH	RD	RED
BK	BLACK	BN	BROWN

## 5.2 Electrical Wiring

- Inoddr Unit

Models GWHN28FANK1A1A/I(CA152N0450) GWCN28FANK1A1A/I(CA152N0441)

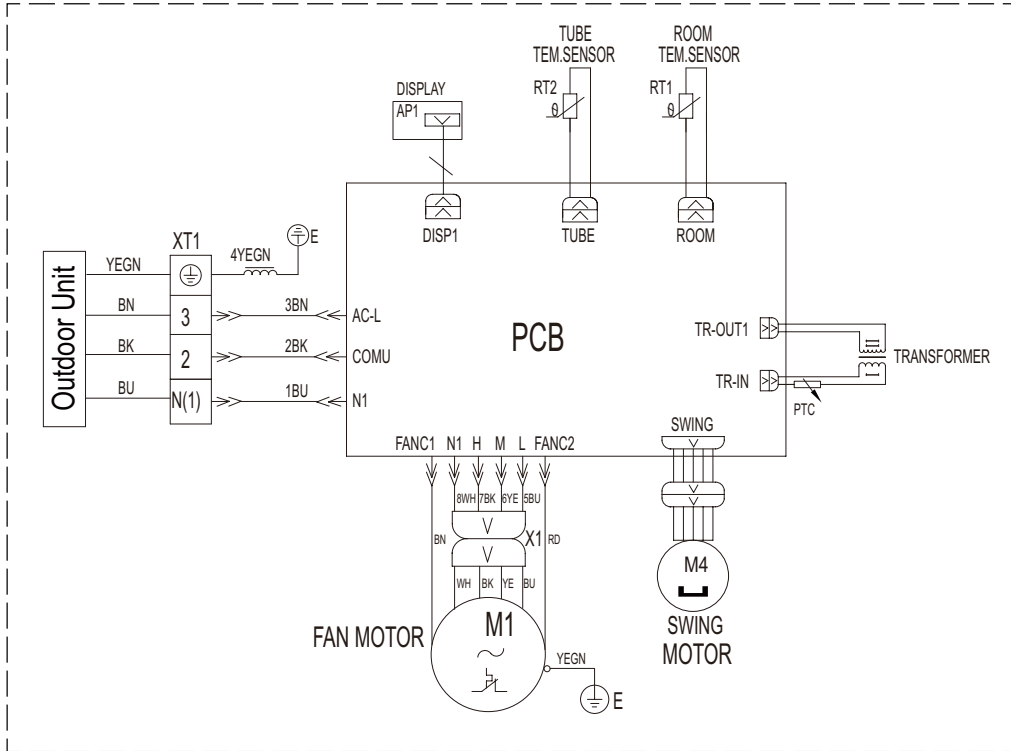

Model GWCN28FANK1A1A/I(CA152N0443)

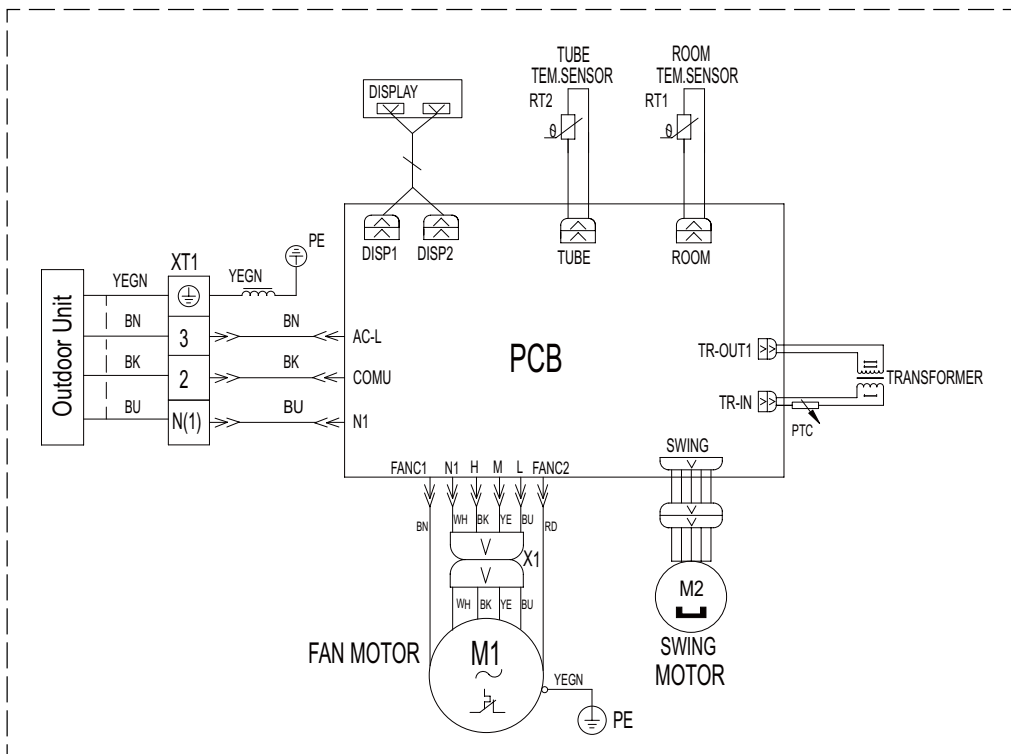

● Outdoor Unit

Model GWCN28FANK1A1A/O

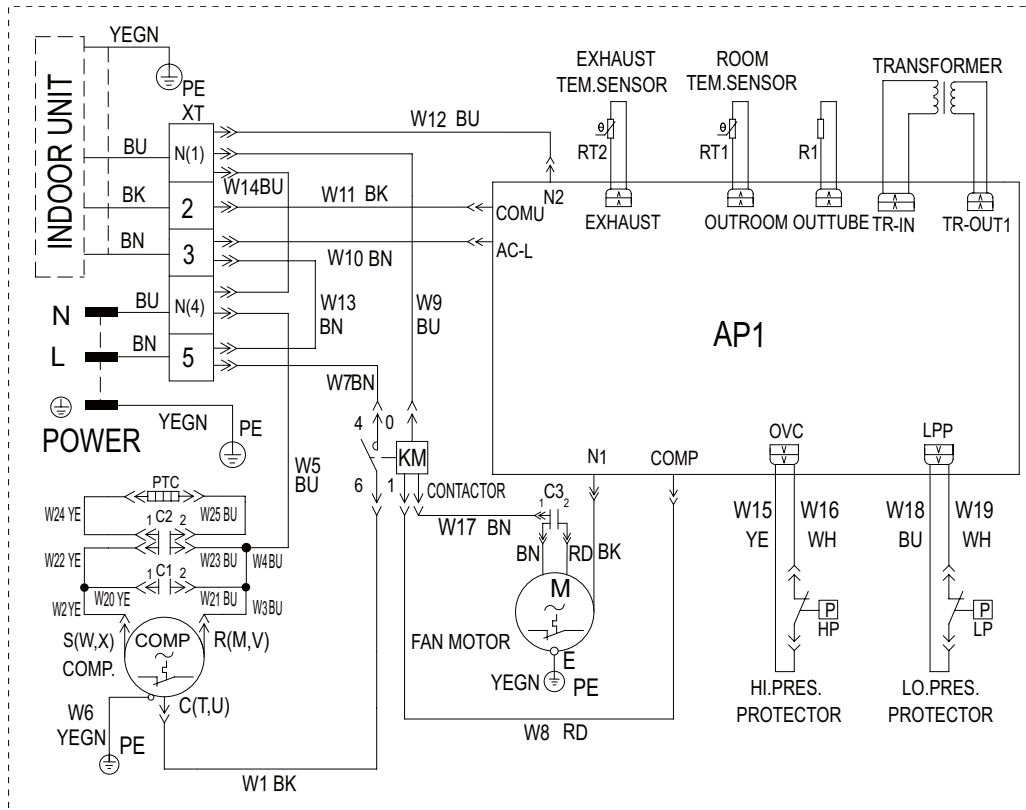

Model GWHN28FANK1A1A/O

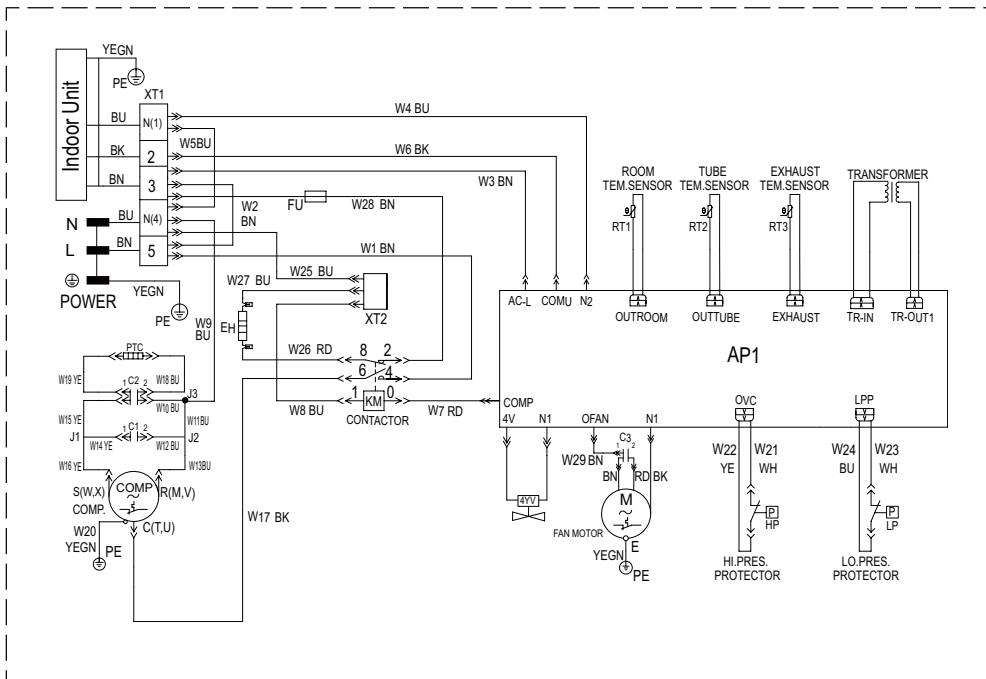

These circuit diagrams are subject to change without notice, please refer to the one supplied with the unit.

### 5.3 Printed Circuit Board

Indoor Unit

- **TOP VIEW** Models GWCN28FANK1A1A/I(CA152N0441) GWHN28FANK1A1A/I(CA152N0450)

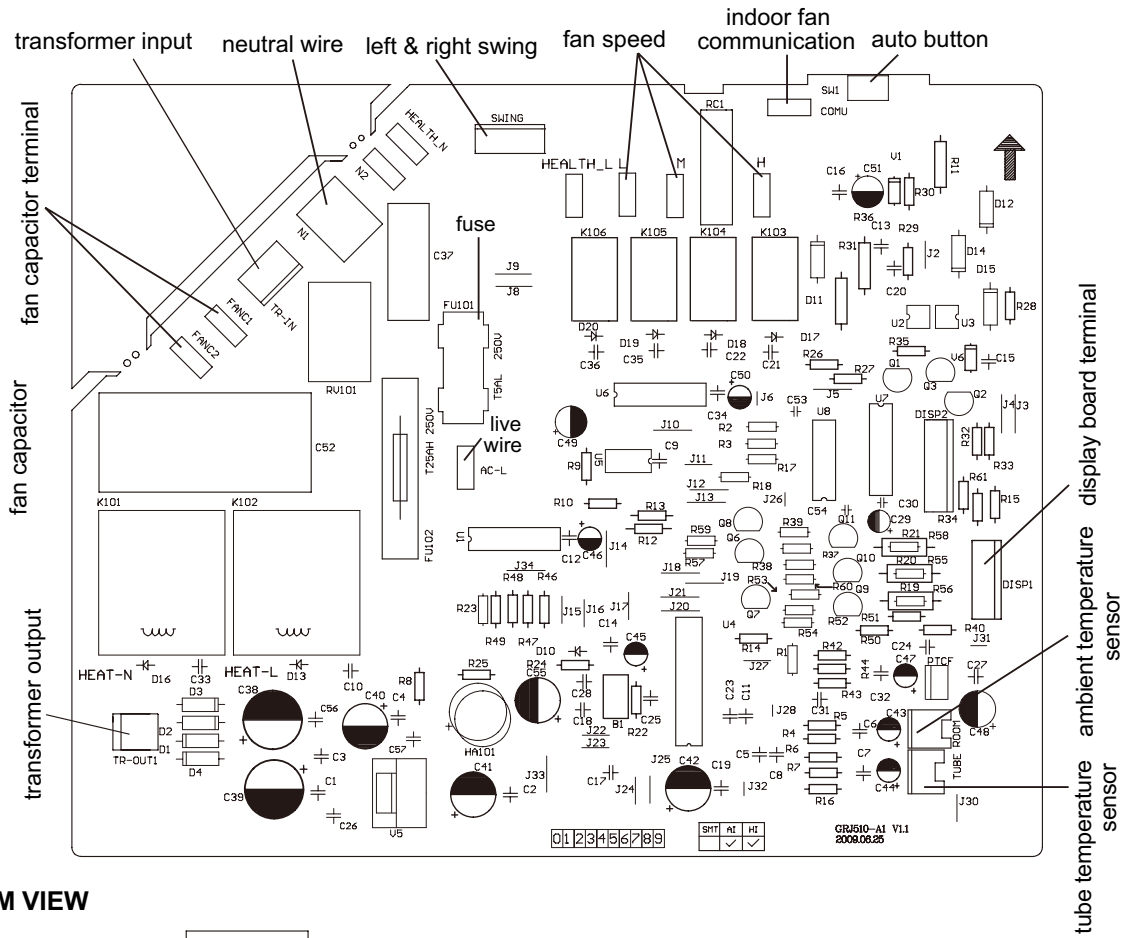

- **BOTTOM VIEW**





● TOP VIEW

Model GWCN28FANK1A1A/I(CA152N0443)

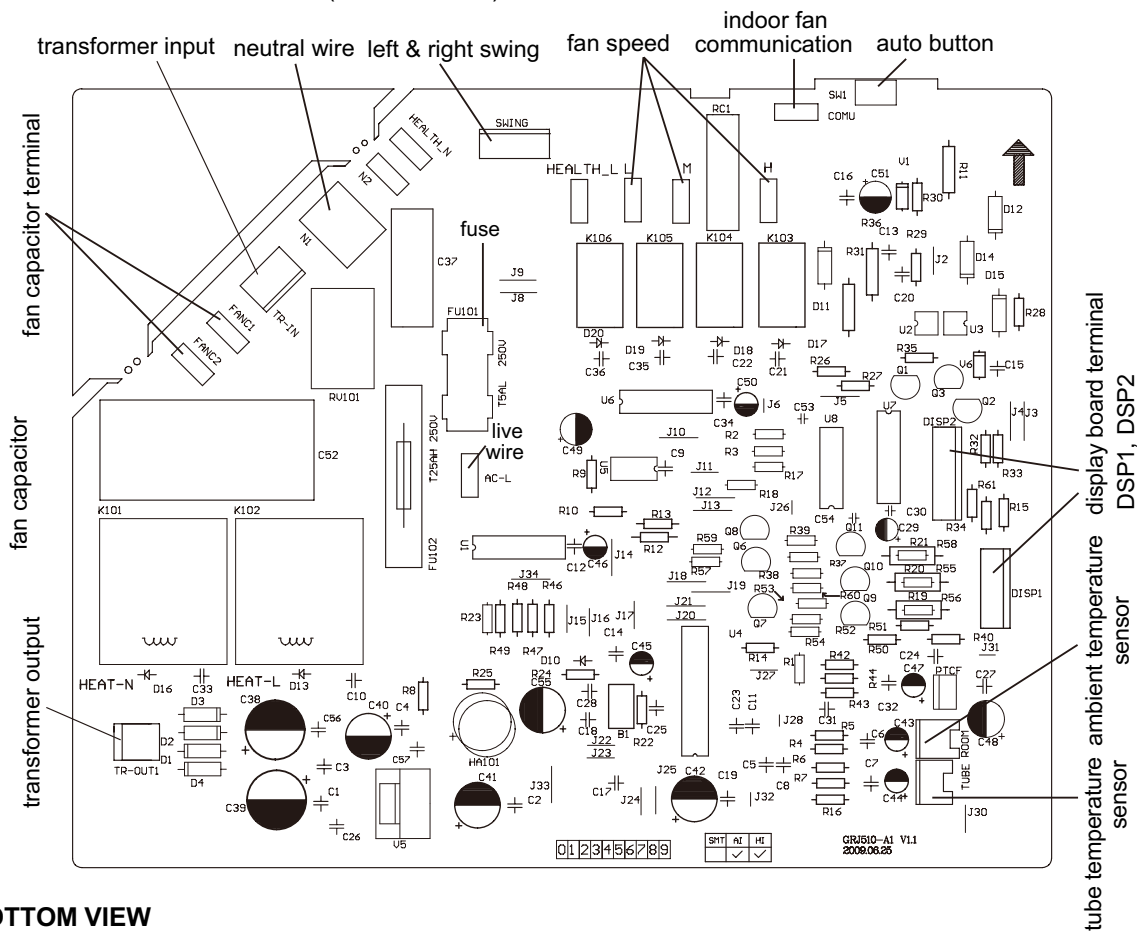

● BOTTOM VIEW



Outdoor Unit

Model GWCN28FANK1A1A/O

● TOP VIEW

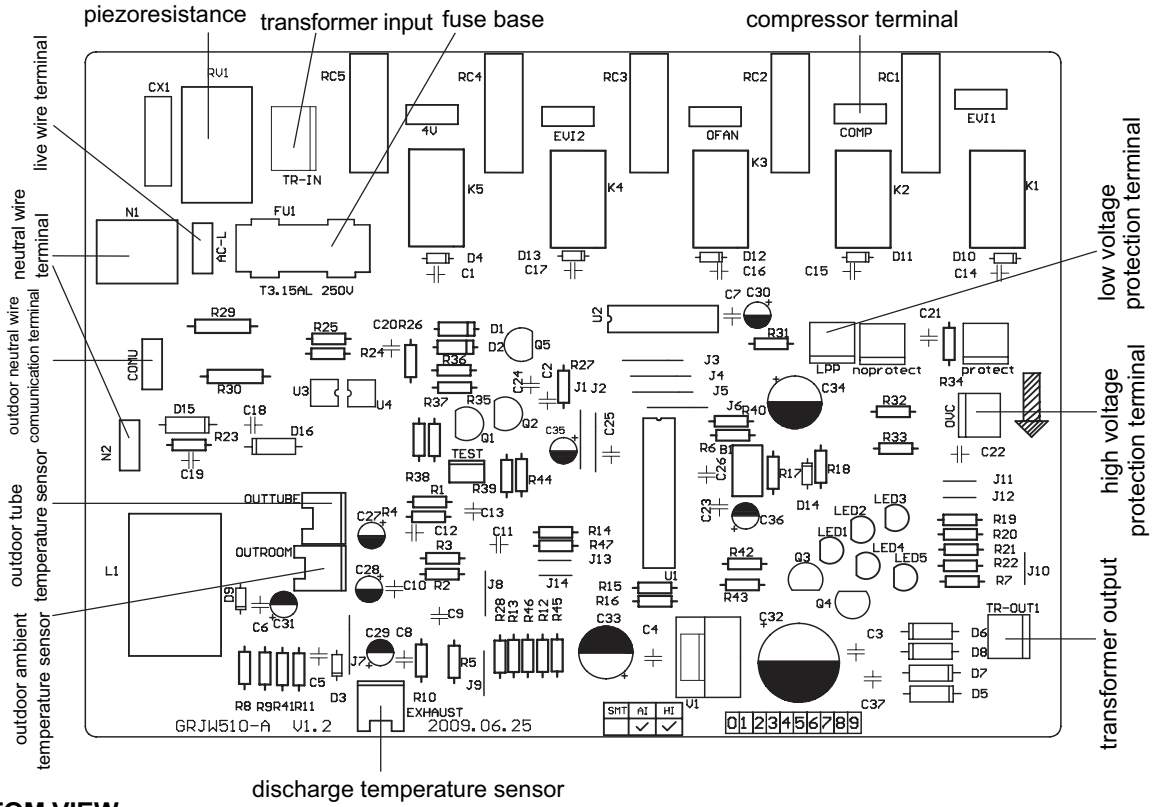

● BOTTOM VIEW

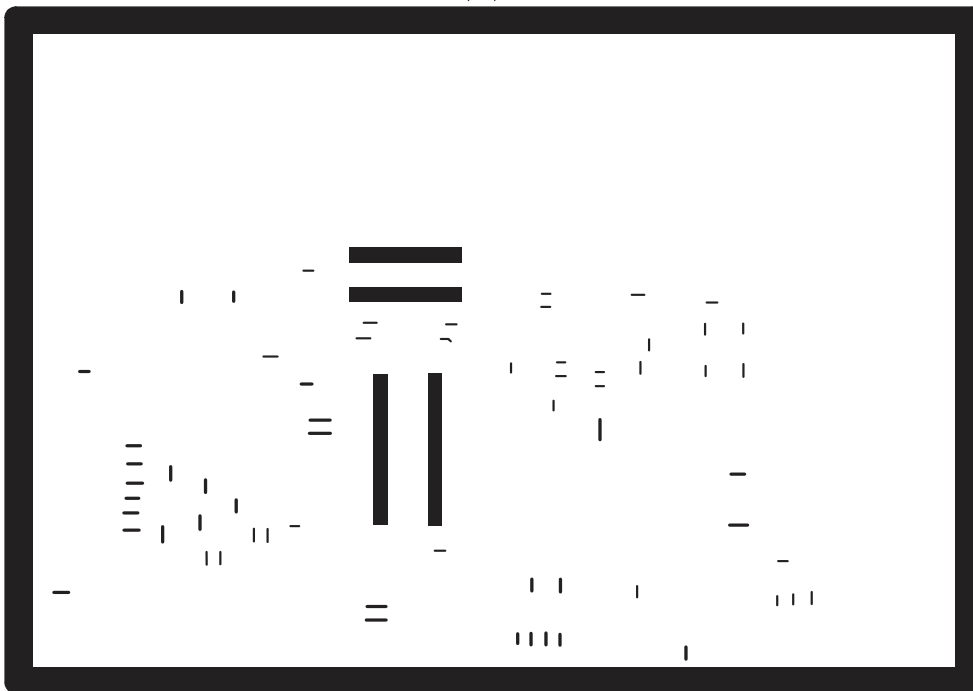

● TOP VIEW

Model GWHN28FANK1A1A/O

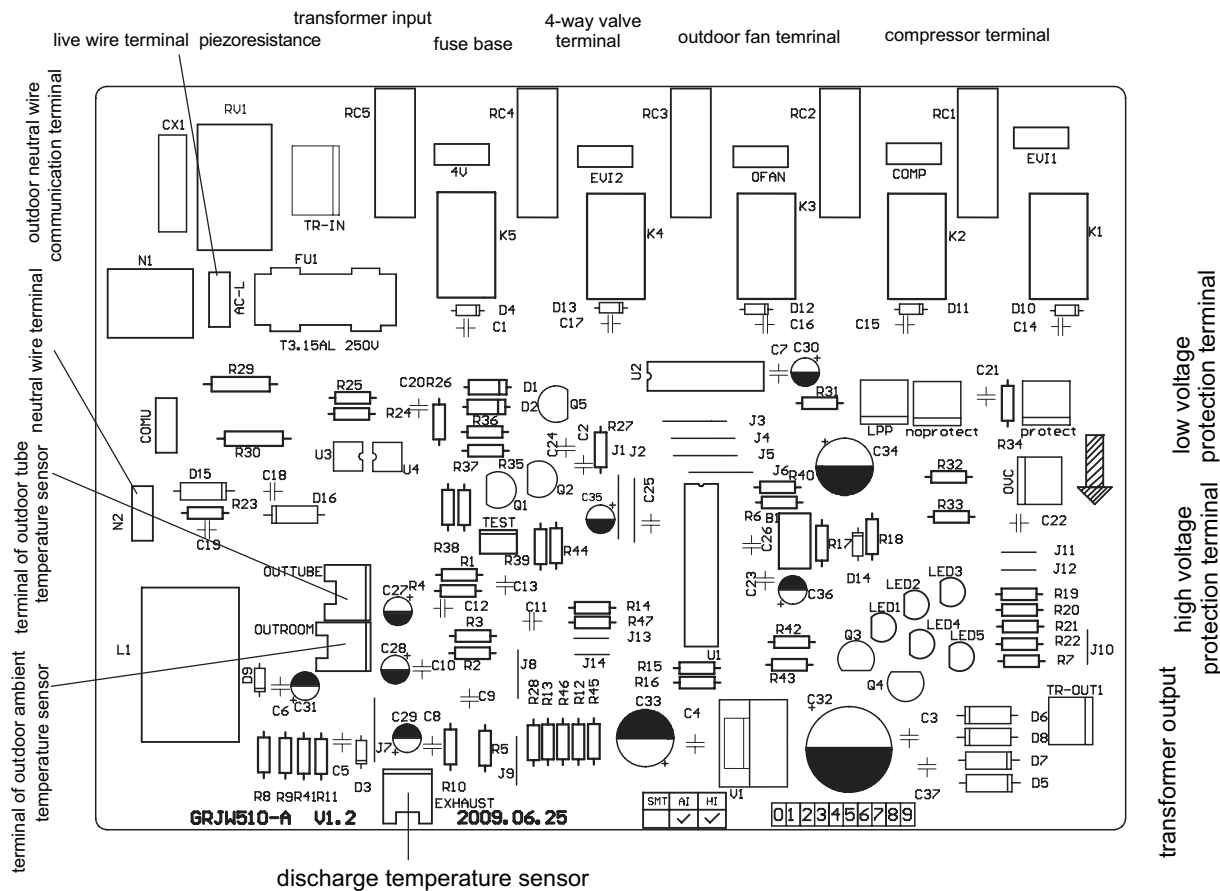

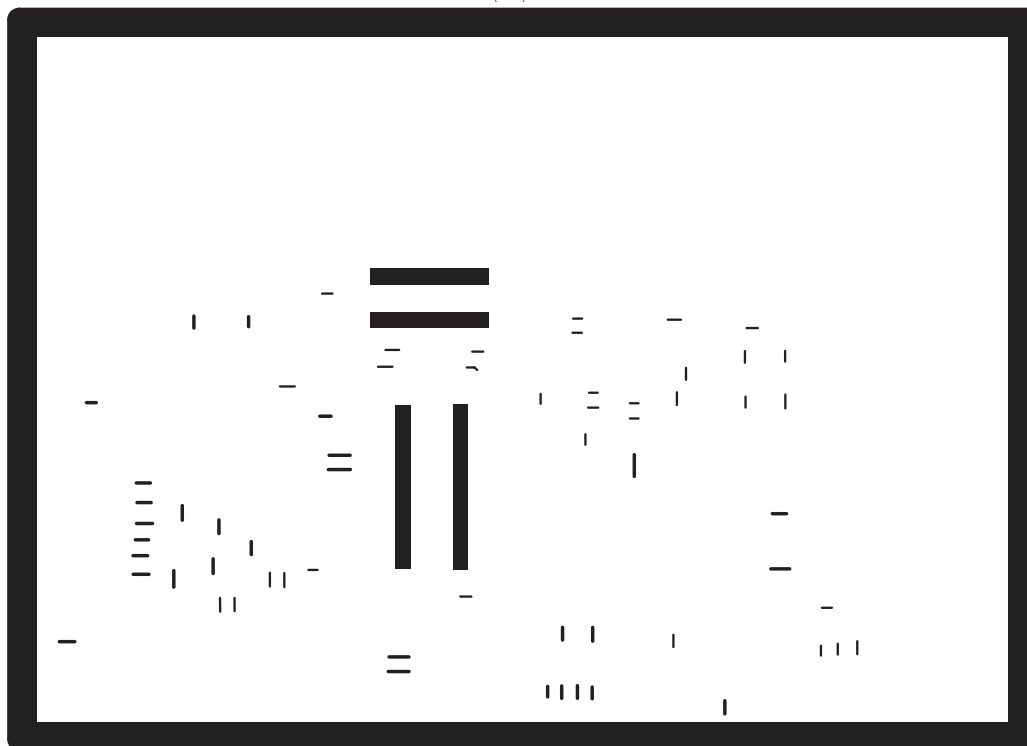

● BOTTOM VIEW



## 6. Function and Control





### 6.1 Operation of Remote Controller

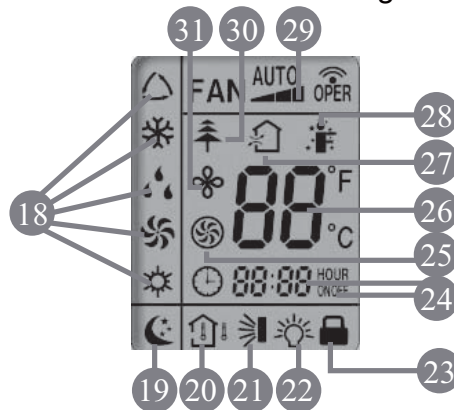

- 1 **ON/OFF**  
Press it to start or stop operation.
- 2 **- :**  
Press it to decrease temperature setting.
- 3 **+**  
Press it to increase temperature setting.
- 4 **FAN**  
Press it to set fan speed.
- 5 **MODE**  
Press it to select operation mode (AUTO/COOL/DRY/FAN/HEAT).
- 6 **I FEEL**
- 7   
Press it to set HEALTH function
- 8   
Press it to set AIR function.
- 9 **CLOCK**  
Press it set clock.
- 10 **TIMER ON**  
Press it to set auto-on timer.
- 11   
Press it set swing angle.
- 12 **X-FAN** (X-FAN is the alternative expression of BLOW for the purpose of understanding.)
- 13 **TEMP**
- 14 **TIMER OFF**  
Press it to set auto-off timer
- 15 **TURBO**
- 16 **SLEEP**
- 17 **LIGHT**  
Press it to turn on/off the light.



**18** **MODE icon:**

If MODE button is pressed, current operation mode icon  (AUTO),  (COOL),  (DRY),  (FAN) or  (HEAT only for heat pump models) will show.