

1 Summary and features



Model	Remarks
GWHN24FANK3A1B	1Ph 220V-240~ 50Hz R410a



Model	Remarks
<p data-bbox="488 1731 737 1799">GWHN24FANK3A1A GWHN28FANK3A1A</p>	<p data-bbox="1182 1731 1406 1799">1Ph 220V~ 60Hz R22</p>

2 Technical specifications

Model	GWHN24FANK3A1B		
Function	COOLING	HEATING	
Rated Voltage	220-240V~		
Rated Frequency	50Hz		
Total Capacity (W/Btu/h)	7038(W) / 24000(Btu/h)	7600(W)/ 26000(Btu/h)	
Power Input (W)	2330W	2300W	
Rated Input (W)	3600W	3100W	
Rated Current (A)	16.4	14.1	
Air Flow Volume (m3/h) (H/M/L)**	1200		
Dehumidifying Volume (l/h)	3		
EER / C.O.P (W/W)	3.01/ 3.3		
Energy Class	/		
Indoor unit	Model of Indoor Unit	GWHN24FANK3A1B/I	
	Fan Motor Speed (r/min) (H/M/L)	1400/1300/1200	
	Output of Fan Motor (w)	40	
	Input of Heater (w)	/	
	Fan Motor Capacitor (uF)	3	
	Fan Motor RLA(A)	0.18	
	Fan Type-Piece	Cross flow fan – 1	
	Diameter-Length (mm)	φ 106 X 890	
	Evaporator	Aluminum fin-copper tube	
	Pipe Diameter (mm)	φ7	
	Row-Fin Gap(mm)	2-1.5	
	Coil length (l) x height (H) x coil width (L)	903X25.4X381	
	Swing Motor Model	MP24GA	
	Output of Swing Motor (W)	2	
	Fuse (A)	PCB 3.15A Transformer 0.4/0.1A	
	Sound Pressure Level dB (A) (H/M/L)	49/47/45	
	Sound Power Level dB (A) (H/M/L)***	59/57/55	
	Dimension (W/H/D) (mm)	1178 X326X227	
	Dimension of Package(W/H/D)(mm)	1265X417X328	
	Net Weight /Gross Weight (kg)	17.5/24	

Outdoor unit	Model of Outdoor Unit		GWHN24FANK3A1B /O
	Compressor Manufacturer/trademark		Hitachi(ShangHai)
	Compressor Model		ATH290CV-C9LU
	Compressor Type		ROTARY
	L.R.A. (A)		60
	Compressor RLA(A)		11.2
	Compressor Power Input(W)		2475
	Overload Protector		PUT-IN
	Throttling Method		Capillary
	Starting Method		Capacitor
	Working Temp Range (°C)		-7≤T≤46
	Condenser		Aluminum fin-copper tube
	Pipe Diameter (mm)		φ9.52
	Rows-Fin Gap(mm)		2-1.4
	Coil length(l) x height(H) x coil width(L)		765X660X22
	Fan Motor Speed (rpm) (H/ML)		780
	Output of Fan Motor (W)		68
	Fan Motor RLA(A)		0.27
	Fan Motor Capacitor (uF)		3.5
	Air Flow Volume of Outdoor Unit		-
	Fan Type-Piece		Axial fan -1
	Fan Diameter (mm)		φ460
	Defrosting Method		Auto defrost
	Climate Type		T1
	Isolation		I
	Moisture Protection		IP24
Permissible Excessive Operating Pressure for the Discharge Side(MPa)		2.4	
Permissible Excessive Operating Pressure for the Suction Side(MPa)		0.6	
Sound Pressure Level dB (A) (H/ML)		58	
Sound Power Level dB (A) (H/ML)		68	
Dimension (W/H/D) (mm)		1018X700X412	
Dimension of Package (L/H/W)(mm)		1100X755X450	
Net Weight /Gross Weight (kg)		55/60	
Refrigerant Charge (kg)		R410a / 2.0kg	
Connecti on Pipe	Length (m)		/
	Gas additional charge(g/m)		30
	Outer Diameter	Liquid Pipe (mm)	φ9.52(3/8")
		Gas Pipe (mm)	φ16(5/8")
	Max Distance	Height (m)	15
	Length (m)	30	

The above data is subject to change without notice. Please refer to the nameplate of the unit.

Model		GWHN24FANK3A1A	
Function		COOLING	HEATING
Rated Voltage		220-240V~	
Rated Frequency		50Hz	
Total Capacity (W/Btu/h)		7050(W) / 24000(Btu/h)	7600(W)/ 26000(Btu/h)
Power Input (W)		2190W	2070W
Rated Input (W)		3200W	3000W
Rated Current (A)		13.9	13
Air Flow Volume (m ³ /h) (H/ML)**		1200	
Dehumidifying Volume (l/h)		3	
EER / C.O.P (W/W)		3.21/3.67	
Energy Class		A	
Indoor unit	Model of Indoor Unit	GWHN24FANK3A1A/I	
	Fan Motor Speed (r/min) (H/ML)	1400/1300/1200	
	Output of Fan Motor (w)	40	
	Input of Heater (w)	/	
	Fan Motor Capacitor (uF)	3.5	
	Fan Motor RLA(A)	0.18	
	Fan Type-Piece	Cross flow fan – 1	
	Diameter-Length (mm)	φ 106 X 890	
	Evaporator	Aluminum fin-copper tube	
	Pipe Diameter (mm)	φ7	
	Row-Fin Gap(mm)	2-1.5	
	Coil length (l) x height (H) x coil width (L)	903X25.4X381	
	Swing Motor Model	MP24GA	
	Output of Swing Motor (W)	2	
	Fuse (A)	PCB 3.15A Transformer 0.4/0.1A	
	Sound Pressure Level dB (A) (H/ML)	49/47/45	
	Sound Power Level dB (A) (H/ML)***	59/57/55	
	Dimension (W/H/D) (mm)	1178 X326X227	
Dimension of Package(W/H/D)(mm)	1265X417X328		
Net Weight /Gross Weight (kg)	17.5/24		

Outdoor unit	Model of Outdoor Unit		GWHN24FANK3A1A/O
	Compressor Manufacturer/trademark		Panasonic Wanbao(Guangzhou)
	Compressor Model		5VS270EAA21
	Compressor Type		ROTARY
	L.R.A. (A)		56
	Compressor RLA(A)		9.7
	Compressor Power Input(W)		2265
	Overload Protector		PUT-IN
	Throttling Method		Capillary
	Starting Method		Capacitor
	Working Temp Range (°C)		-7≤T≤46
	Condenser		Aluminum fin-copper tube
	Pipe Diameter (mm)		φ9.52
	Rows-Fin Gap(mm)		2-1.5
	Coil length(l) x height(H) x coil width(L)		730.5X813X44
	Fan Motor Speed (rpm) (H/ML)		815
	Output of Fan Motor (W)		60
	Fan Motor RLA(A)		0.27
	Fan Motor Capacitor (uF)		3.5
	Air Flow Volume of Outdoor Unit		-
	Fan Type-Piece		Axial fan -1
	Fan Diameter (mm)		φ460
	Defrosting Method		Auto defrost
	Climate Type		T1
	Isolation		I
	Moisture Protection		IP24
Permissible Excessive Operating Pressure for the Discharge Side(MPa)		3.8	
Permissible Excessive Operating Pressure for the Suction Side(MPa)		1.2	
Sound Pressure Level dB (A) (H/ML)		58	
Sound Power Level dB (A) (H/ML)		68	
Dimension (W/H/D) (mm)		1006X840X412	
Dimension of Package (L/H/W)(mm)		1100X905X450	
Net Weight /Gross Weight (kg)		72/77	
Refrigerant Charge (kg)		R410a / 2.45kg	
Connecti on Pipe	Length (m)		/
	Gas additional charge(g/m)		30
	Outer Diameter	Liquid Pipe (mm)	φ9.52(3/8")
		Gas Pipe (mm)	φ16(5/8")
	Max Distance	Height (m)	15
	Length (m)	30	

The above data is subject to change without notice. Please refer to the nameplate of the unit.

Model		GWHN28FANK3A1A	
Function		COOLING	HEATING
Rated Voltage		220-240V~	
Rated Frequency		50Hz	
Total Capacity (W/Btu/h)		8000(W) / 27300(Btu/h)	8800(W)/ 30000(Btu/h)
Power Input (W)		2850W	2600W
Rated Input (W)		3700W	3500W
Rated Current (A)		16.1	15.2
Air Flow Volume (m ³ /h) (H/ML)**		1200	
Dehumidifying Volume (l/h)		3	
EER / C.O.P (W/W)		2.81/3.38	
Energy Class		C	
Indoor unit	Model of Indoor Unit		GWHN28FANK3A1A/I
	Fan Motor Speed (r/min) (H/ML)		1400/1300/1200
	Output of Fan Motor (w)		40
	Input of Heater (w)		/
	Fan Motor Capacitor (uF)		3.5
	Fan Motor RLA(A)		0.18
	Fan Type-Piece		Cross flow fan – 1
	Diameter-Length (mm)		φ 106 X 890
	Evaporator		Aluminum fin-copper tube
	Pipe Diameter (mm)		φ7
	Row-Fin Gap(mm)		2-1.5
	Coil length (l) x height (H) x coil width (L)		903X25.4X381
	Swing Motor Model		MP24GA
	Output of Swing Motor (W)		2
	Fuse (A)		PCB 3.15A Transformer 0.4/0.1A
	Sound Pressure Level dB (A) (H/ML)		49/47/45
	Sound Power Level dB (A) (H/ML)***		59/57/55
	Dimension (W/H/D) (mm)		1178 X326X227
Dimension of Package(W/H/D)(mm)		1265X417X328	
Net Weight /Gross Weight (kg)		17.5/24	

Outdoor unit	Model of Outdoor Unit		GWHN28FANK3A1A/O
	Compressor Manufacturer/trademark		Shanghai Hitachi
	Compressor Model		ATH325CV-C9LU
	Compressor Type		ROTARY
	L.R.A. (A)		68
	Compressor RLA(A)		11.8
	Compressor Power Input(W)		2710
	Overload Protector		PUT-IN
	Throttling Method		Capillary
	Starting Method		Capacitor
	Working Temp Range (°C)		-7≤T≤46
	Condenser		Aluminum fin-copper tube
	Pipe Diameter (mm)		φ9.52
	Rows-Fin Gap(mm)		2-1.5
	Coil length(l) x height(H) x coil width(L)		730.5X813X44
	Fan Motor Speed (rpm) (H/ML)		815
	Output of Fan Motor (W)		60
	Fan Motor RLA(A)		0.27
	Fan Motor Capacitor (uF)		3.5
	Air Flow Volume of Outdoor Unit		-
	Fan Type-Piece		Axial fan -1
	Fan Diameter (mm)		φ460
	Defrosting Method		Auto defrost
	Climate Type		T1
	Isolation		I
	Moisture Protection		IP24
Permissible Excessive Operating Pressure for the Discharge Side(MPa)		3.8	
Permissible Excessive Operating Pressure for the Suction Side(MPa)		1.2	
Sound Pressure Level dB (A) (H/ML)		58	
Sound Power Level dB (A) (H/ML)		68	
Dimension (W/H/D) (mm)		1006X840X412	
Dimension of Package (L/H/W)(mm)		1100X905X450	
Net Weight /Gross Weight (kg)		72/77	
Refrigerant Charge (kg)		R410a / 2.6kg	
Connecti on Pipe	Length (m)		/
	Gas additional charge(g/m)		30
	Outer Diameter	Liquid Pipe (mm)	φ9.52(3/8")
		Gas Pipe (mm)	φ16(5/8")
	Max Distance	Height (m)	15
	Length (m)	30	

The above data is subject to change without notice. Please refer to the nameplate of the unit.

3 Part name

Indoor unit

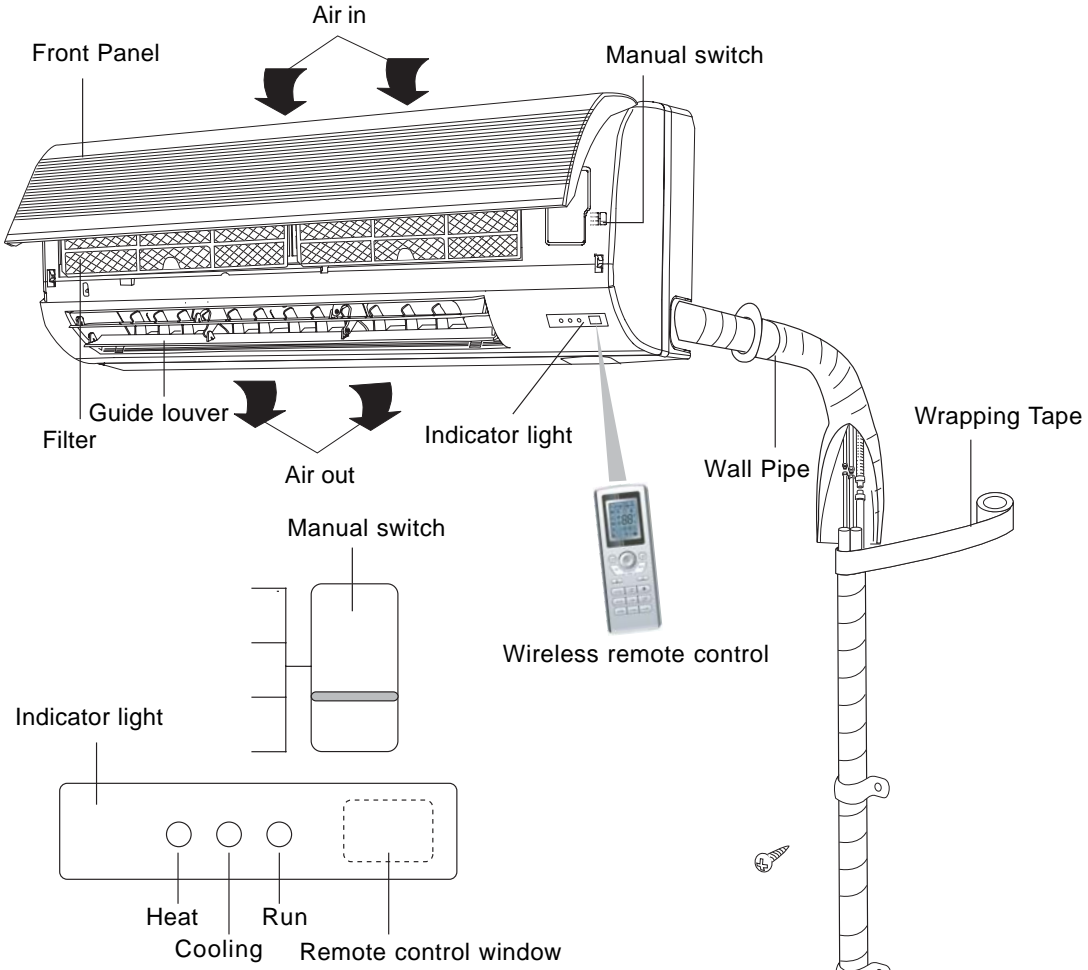

Outdoor unit

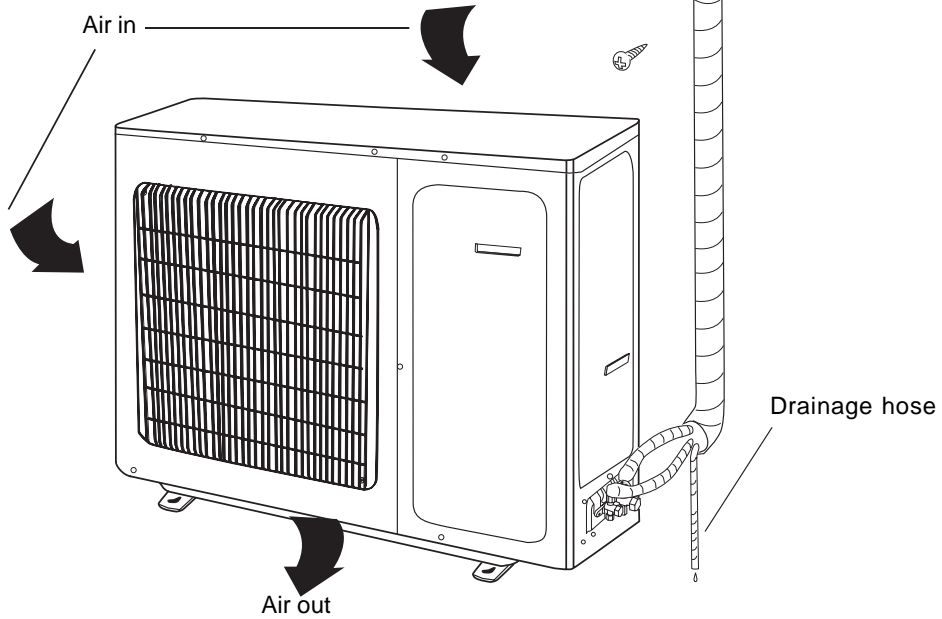

4 Outline and installation dimension

4.1 Outline and installation dimensions of indoor unit

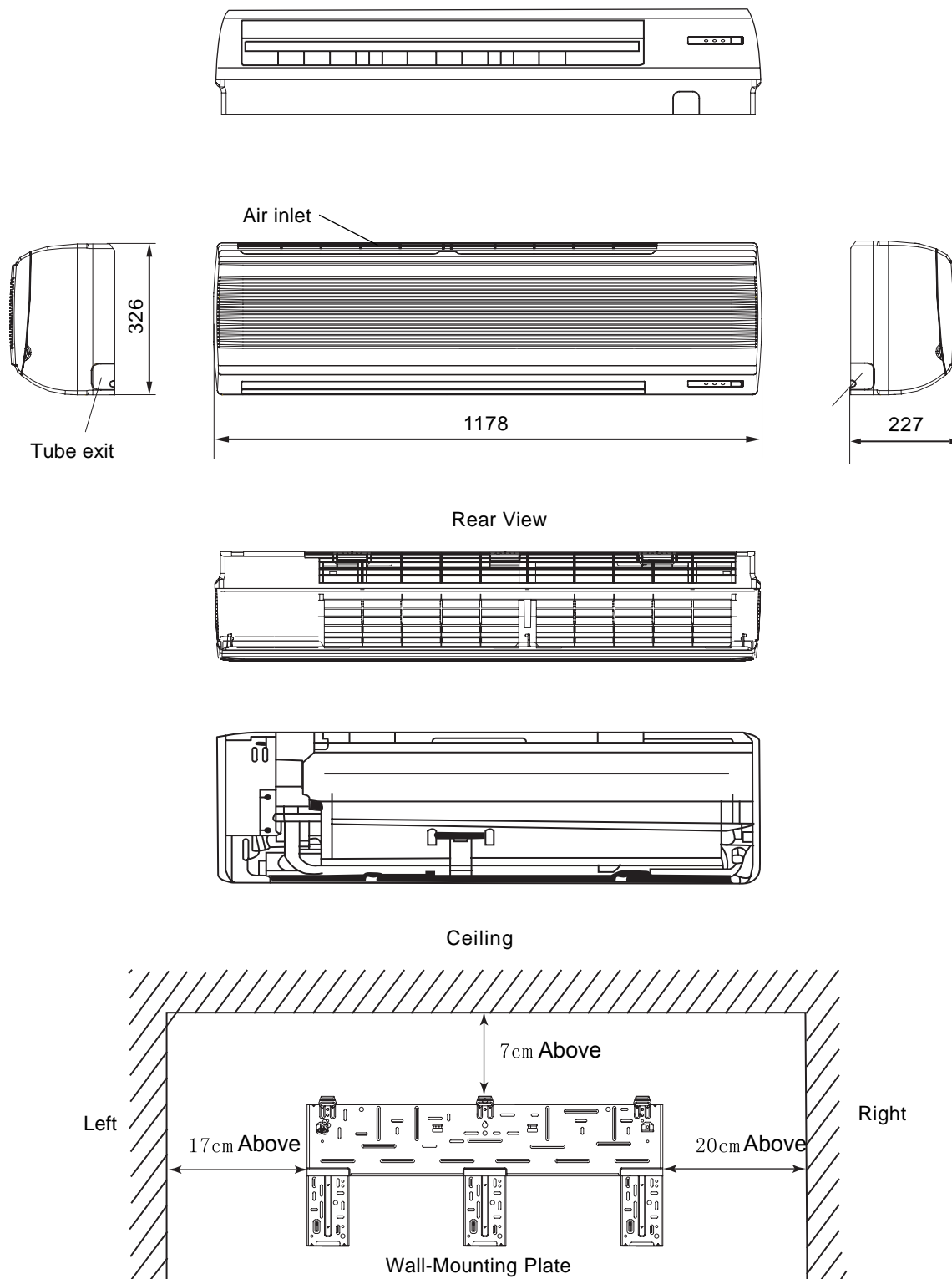

4. 2 Outline and installation dimensions of outdoor unit

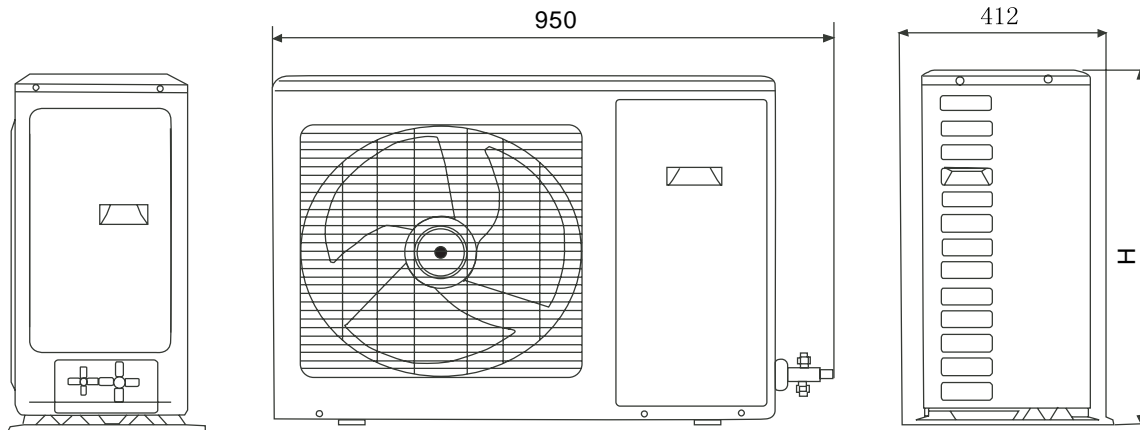

Model	H(mm)
GWHN24FANK3A1B	700
GWHN24FANK3A1A	840
GWHN28FANK3A1A	840

Unit:mm

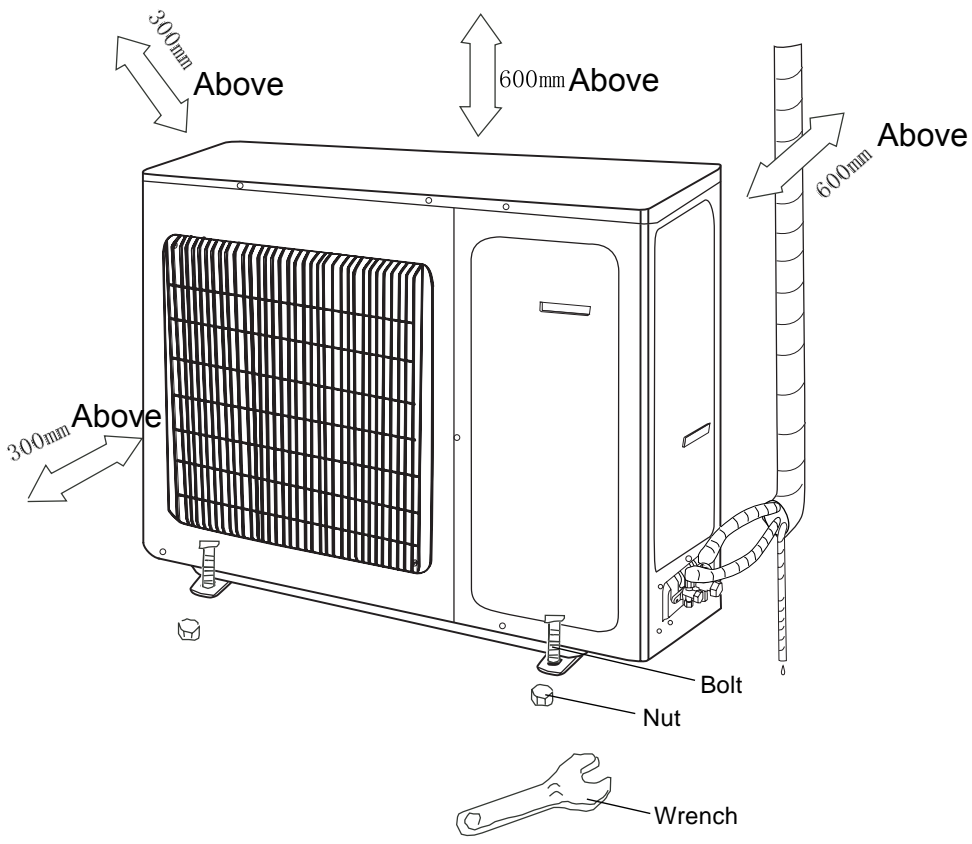

5 Electrical circuit diagram

GWHN24FANK3A1A GWHN28FANK3A1A

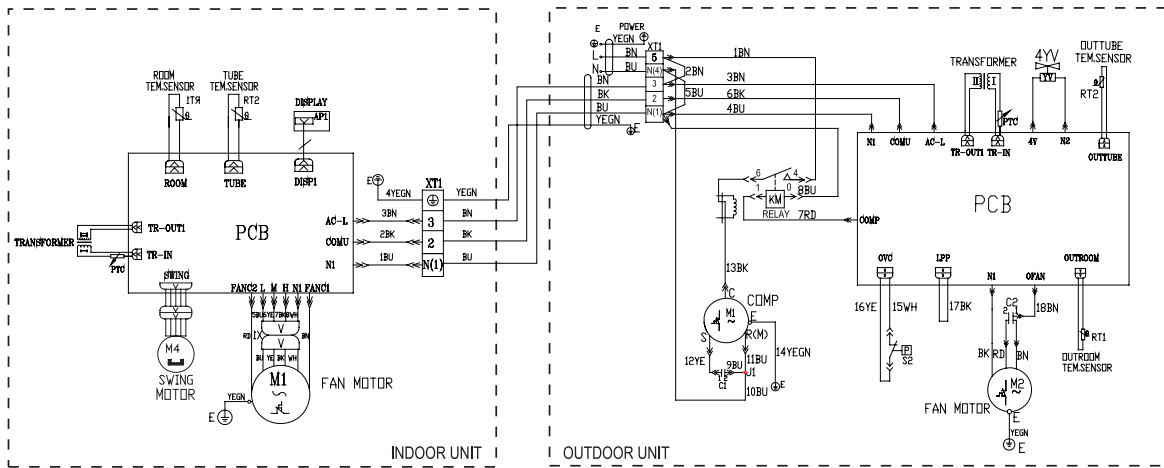

GWHN24FANK3A1B

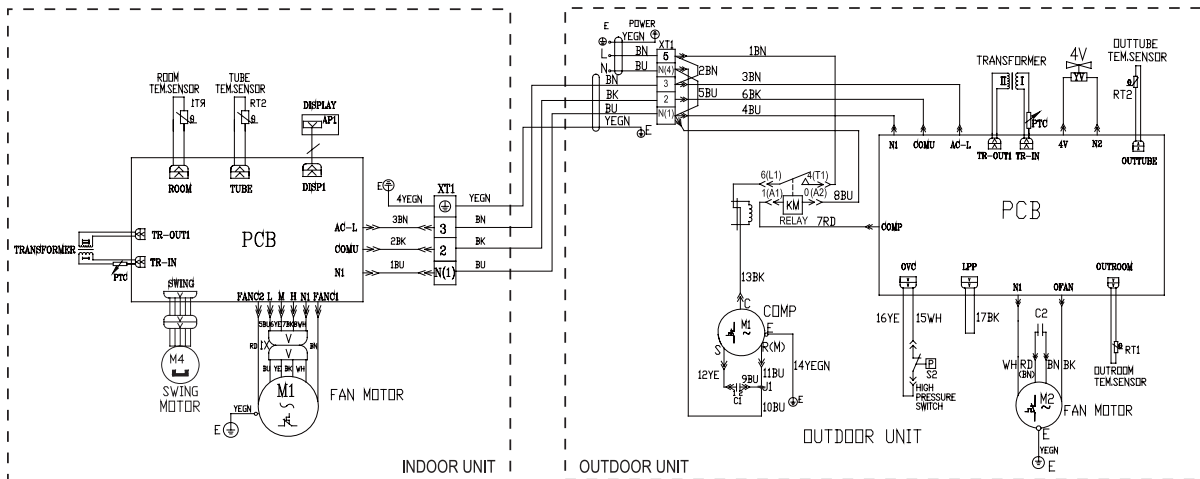

These circuit diagrams are subject to change without notice, please refer to the one supplied with the unit.

6 PCB function manual and operation method

6.1 Manual of functions of remote controller 1

The centigrade is used for the following function manual, if there will be the Fahrenheit degree, that will be $TF = TCX1.8 + 32$.

1 Temperature parameter

- ◆ The room setting temperature (T_{set})
- ◆ The room ambient temperature (T_{amb})

2 Fundamental functions of the system

Under each mode, once compressor start up, within 6mins, it will work for a long time, once it stopped, after 3mins delayed, it will start up.

(1) COOL mode

① The conditions and processes of cooling

If $T_{amb} \geq T_{set} + 1^\circ C$, COOL mode will act, compressor and outdoor fan will run, indoor fan will run at the set speed.

If $T_{amb} \leq T_{set} - 1^\circ C$, compressor and outdoor fan will stop, indoor fan runs at setting fan speed.

If $T_{set} - 1^\circ C < T_{amb} < T_{set} + 1^\circ C$, the unit will keep running in the fuzzy mode.

➤ In this mode, the reversal valve will not power on, the setting temp. range 16~30°C

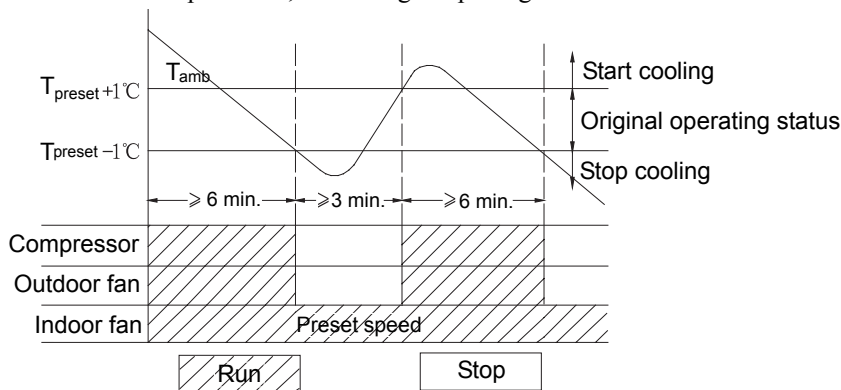

(2) DRY Modes

① The conditions and process of DRY

When $T_{amb} > T_{preset} + 2^\circ C$, the unit will run under DRY cooling mode, in which case the compressor and outdoor fan will be started and the indoor fan will run at low speed.

When $T_{preset} - 2^\circ C \leq T_{amb} \leq T_{preset} + 2^\circ C$, the unit will run under DRY mode, in which case the indoor fan will keep run at low speed, the compressor and the outdoor fan will be stopped after 6 minutes. After 4 minutes, the compressor and the outdoor fan will be restarted. The dehumidifying process is so repeated in cycle.

When $T_{amb} < T_{preset} - 2^\circ C$, the compressor and outdoor fan will be stopped, the indoor fan will run at low speed.

➤ Under this mode, the switchover valve will not be powered on, and the setting temperature range is 16 ~ 30°C.

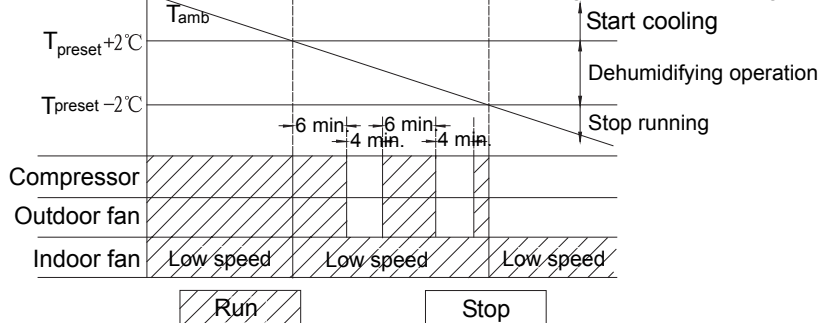

(3) HEAT Mode (cooling only unit only)

① The conditions and processes of heating

When $T_{amb} \leq T_{set} + 2^{\circ}\text{C}$, the system enters heating running, in this case, the reversal valve, compressor, outer fan enter simultaneously running. The indoor fan will delay at most for 0.5min to run.

When $T_{amb} \geq T_{set} + 4^{\circ}\text{C}$, the compressor and outdoor fan will stop, but the reversal valve is still with power on, the indoor unit will run at setting fan speed for 60s then will stop.

When $T_{set} + 2^{\circ}\text{C} < T_{amb} < T_{set} + 4^{\circ}\text{C}$, the unit will maintain its original operating status.

➤ Under this mode, the switchover valve will be powered on, and the setting temperature range is $16 \sim 30^{\circ}\text{C}$.

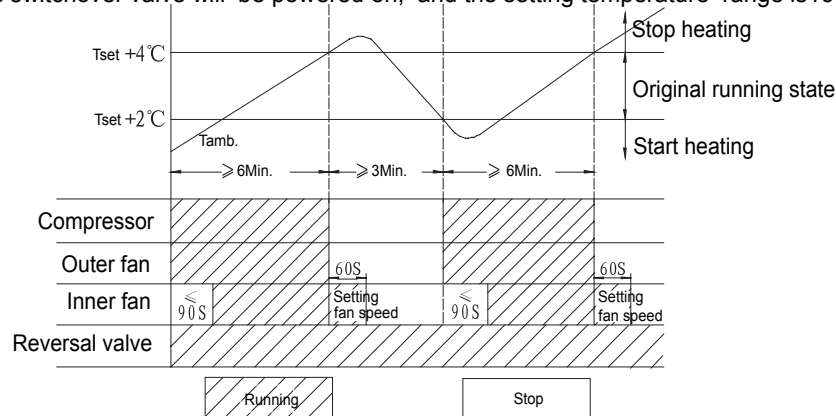

② The conditions and processes of defrosting

When the defrosting condition is satisfied, the system will enter into defrosting status, at this time, the four-way valve, inner and outer fan will stop to run, the heating indicator will blink. When defrosting is running 10mins or condensor tube temperature will resume to normal, after the defrosting finished, at this time, the outer fan, four-way valve will put into operation, inner fan will delay 90s at least for running.

Heating indicator stop blinking.

③ Four-way valve anti-liquid shock control mode

In heat mode, the unit will off, when switching from Heat mode to other mode, the four-way valve will power off after compressor stopped for 2mins.

(4) Fan mode

The indoor fan runs at setting speed, temperature setting range is $16\text{-}30^{\circ}\text{C}$, the initial value is 25°C .

(5) Auto Mode

Under this mode, the system will automatically select its run mode (cool, dehumidify, heat or fan) with the change of ambient temperature. For protection function, same as under cooling and heating mode.

➤ In Cool and Heat Auto mode: In AUTO mode, if switch from Heat mode to other status, the reversal valve will delay 2mins and will power off.

In Cooling only mode: In this mode, there is no heating function. When remote controlling the heat mode, the unit only receive unit off order.

3 Other control

(1) Sleep function

Under cooling or dehumidifying mode, the preset temperature will automatically rise by 1°C , one hour after setting of sleep program and rise by 1°C after 2hours.

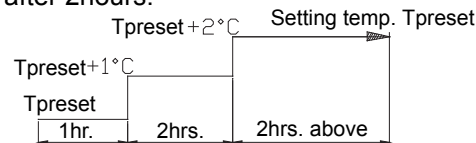

Under heating mode, the preset temperature will automatically decrease by 1°C one hour after setting of sleep program and decrease by another 1°C after 2hours.

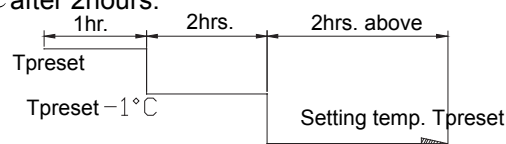

There is no Sleep function in Fan and Auto mode. $T_{preset} - 2^{\circ}\text{C}$

(2) Timing function

Timer setting for hour:

Timer on: If unit is running to set up Timer on, the unit is go on running, if unit is off to set up Timer on, if time out, the unit will run at the presetting mode.

Timer off: If unit is off to set up Timer off, the unit will stand by, if unit is on to set up Timer off, if time out, the unit will stop to work.

Timer change:

a. When unit is under Timer, to operate ON/OFF button on remote control to turn on or turn off the unit, or reset the timer can set up the Timer, the unit will run at the last setting mode.

b. If system is running, to set up the Timer on and Timer off at the same time, the unit will keep running at the current presetting mode, until the Timer off is time out, the unit will stop to work.

c. If system is stop working, at the same time to set up the Timer on and Timer off, the unit is stopping, until the Timer on is time out, the unit will start to work.

Hereafter, when the Timer on in every day time out, the unit will run at presetting mode, when Timer off time out, the unit will stop to work.

d. If the presetting Timer off is the same with Timer on, that the Timer off will be executed

Timer interval setting:

Timer on: At unit off to set up the Timer on function, if time out, the controller will run at the original running status, the timer interval is 0.5hr, setting range is 0.5-24hrs.

Timer off: At unit on to set up the Timer off function, if time out, the timer interval is 0.5hr, setting range is 0.5-24hrs.

(3) Swing control

When power on, the guide louver will anticlockwise rotate to A position to turn off the air vent.

After unit turned on, heating will return to the max. air outlet vent D2 to standby; cooling will firstly rotate to air outlet vent D1 and then return to air outlet vent D1 and then return to L1 to standby; If it is swinging, the cooling is winging between L1 and D1; the heating is swinging between the L and D2; Or if it stays, the swing will rotate to the corresponding staying status.

When unit is off, the guide louver will anticlockwise rotate to A position to turn off the air vent.

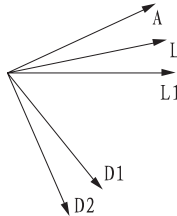

(4) Buzzer

The controller is powered on and detect the signal received, the buzzer will beep.

(5) Auto button

When whole unit is running, press this button, the unit is off; when whole unit stop, press this button, the unit will run at auto, auto fan, and swing mode.

(6) Auto fan speed control

Under this mode, inner fan will accord to ambient temperature change automatically select Hi, Mid, Low three speed.

(7) Indicator light

Running indicator (Red) : When remote control power on, the indicator will blink, when unit is on, it will turn on, while unit off, it is off. If malfunction happen, it will blink.

Cool, Dehumidify indicator (Blue):In Cool or Dry mode, auto cool or auto dehumidify mode, it will turn on, other mode it is off, in Fan mode, the running indicator will turn on.

Heat indicator (Yellow): In Auto Heat or Heat mode, the light will turn on, it will blink when defrosting, other mode it is off.

(8) Other

If use the remote controller to operate, if the remote controller displays Heat mode, but the unit is cooling only unit, except receiving unit off signal, the other signal cannot receive.

4 Protection method

(1) Anti-freezing protection

In Cool or Dehumidify mode, if system anti-freezing protection is detected that the compressor, outdoor fan will stop to run, inner fan, swing motor will keep the original running status.

When anti-freezing protection release and compressor has stopped 3mins, the running indicator will not turn off, the controller will run at presetting mode.

(2) System high-pressure protection

When detecting high-pressure protection, will turn off all overloads, all buttons and remote control signal will be shielded the running indicator will blink;If detected the compressor high-pressure protection released, the buttons and remote control shield will be released, the running indicator is still blink, it is need to press the ON/OFF button to turn off the unit, after the running indicator turns off, repress the ON/OFF button to resume to run.

(3) System low-pressure protection

1. After compressor started up 2mins later to start detect low-pressure switch signal, if continuously 1min. detected the low-pressure switch break, the whole unit will stop to run, indicator will blink, 3mins later, if low-pressure switch resumed that the unit will automatically resume to run; If continuously low-pressure switch protection act for twice, the indicator blink but it cannot resume automatically, in order to inform user air exhaust; Press ON/OFF button to turn off the unit, then repress ON/OFF button and low-pressure switch has resumed to run.
2. During defrosting, do not detect low-pressure switch signal, after defrosting finished, 10mins start to detect.
3. In heating mode, outdoor ambient temperature is lower 0 °C , will shield low-pressure switch for testing.
4. When heating, compressor is running but outdoor fan is stopping (anti-high temp. protection), low-pressure switch test shield, outdoor fan will resume to run and start to test the low-pressure switch signal.
5. When compressor is stopping, continuously 30s detected low-pressure switch break off, the whole unit will stop, the indicator will blink, it cannot resume automatically, it is need to press ON/OFF button to turn off the unit, then repress ON/OFF button, the low-pressure switch can resume to work.
6. Once power on, before the compressor start up, if continuously 1s detect the low-pressure switch break, all loads will not open, to turn off the unit and turn on the unit, until detected the low-pressure switch resume, the loads will run normally.

(4) Air exhaust tube high temperature protection

After compressor started up, continuously 30s detected air exhaust temperature is very high or air exhaust sensor malfunction, running indicator blink. The unit will stop according to indoor ambient temperature meet the setting temperature. After compressor stopped 3mins later, if the air exhaust temperature resume to normal, that the whole unit will resume to run.

If the above protection phenomenon continuously happened twice, the whole unit can not resume to run, the running indicator will blink. Press ON/OFF button to turn off the unit, then repress ON/OFF button, if air exhaust temperature resume to normal that will run at setting mode.

The first time heating start-up of compressor or other modes switch to the Heat mode, the air exhaust temp. protection will be shielded for 1mins.

(5) Anti-high temperature protection

Under the Heat mode, when detected the evaporator tube temp. is very high, the outdoor unit will stop to run; When evaporator tube temp. resume to normal, the outdoor unit will resume to work.

(6) Overcurrent protection

When the compressor is turned on, if it has detected that the current exceed the stated value, the unit will stop as the indoor ambient temp. has arrived at the setting temp., after the compressor has stopped for 3mins, it will resume to run in the original running state, if the protections is more than 6 times (If compressor has continuously work more than 6mins, the protection times will reset), the running indicator will blink, it can not resume to run automatically, it is need to press ON/OFF button to turn off the unit, then repress ON/OFF button to resume to work.

(7) Communication malfunction

When it is detected that the indoor and outdoor units have communication malfunction , the running indicator will blink, the unit will be stopped as the indoor ambient temperature has arrived the setting temperature .

(8) Power off memory function

Memory contents: Mode, Swing, Preset temp., Preset fan speed.

After powered off, when repower on, the unit will memorize the contents and automatically turn on and run.

(9) Indicator display

State	Indicator display	Remark:
High-pressure protection	Outdoor malfunction indicator 1 turns on indoor run indicator blinks	Indoor Run indicator turn off 3s and blinks once
Low-pressure protection	Outdoor malfunction indicator 3 turns on, indicator run indicator blinks	Indoor Run indicator turn off 3s and blink 3 times
Air exhaust protection (compressor over heat protection)	Outdoor malfunction indicator 1, 3 turn on, indoor running indicator blinks	Indoor running indicator turn off 3s and blink four times
Over current protection	Outdoor malfunction indicator 2 turns on, indoor run indicator blinks	Indoor indicator turn off 3s and blinks five times
Communication malfunction	Outdoor malfunction indicators 1,2,3 turn on, indoor run indicator blinks	Indoor indicator turn off 3s and blink six times
Normal communication	Outdoor indicator 4, 5 blink in turn	

When there are several malfunctions existed at the same time, it will display the high level malfunction in priority by a sequence as: communication malfunction→air exhaust protection→over current protection→high pressure protection→low pressure protection.

When unit is on, detect outdoor unit ambient sensor malfunction, when there is short circuit, open circuit, the indoor cooling indicator turns off 3s and blink 3 times.

(1 0) Dry function

1. When unit is on, under the Cool, Dry mode (there is no Dry function in Auto, Heat, Fan mode), can set up the ON/OFF of Dry mode, if the Dry is on, press the ON/OFF button to turn off the unit, the inner fan will run at low fan speed and run for 10mins (within 10mins will run at original running status, the other loads will turn off), then will turn off the whole unit; When the presetting for Dry is off, press the ON/OFF button to turn off the unit directly.

2. When Dry operation is running, operate the Dry button, the inner fan will immediately stop then the guide louver will turn off immediately.
3. When power on, the Dry function is off.
4. When power on, the Dry function is defaulted off on the remote control

(1 1) I Feel function

When controller received the orders that the controller will work according to ambient temperature which is sent by remote control (Except Defrost and Anti-cool wind, it will still adopt the air conditioner self ambient sensor sampling value), the remote control in every 10mins, to sent the ambient temperature value to controller. 11mins later, the controller haven't received the ambient temperature value from the remote control that the air conditioner will run itself ambient temperature. If there is no setting function that the ambient temperature will adopt the AC sensor sampling value. Power off will not memorize this function.

7 Dissassembly Procedures

7.1 Disassembly procedures for indoor unit

Operating Procedures / Photos

1. Disassemble the front panel, filter

Open the front panel ,Push the rotation axes upwards to unloose the clasp, and then pull out the front panel.

Unscrew 1pc screw fixing on the electric box cover, then take down the electric box cover.

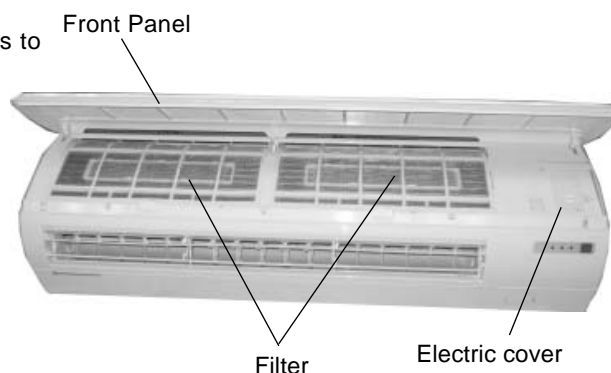

2. Disassemble the guide louver

Bend the guide louver so that the movable lock of guide louver is released to remove the guide louver.

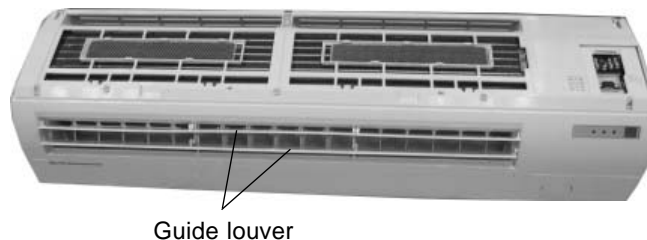

3. Disassemble the front case

Open the 3 screw covers at the front case and screw off 6 screws. Pull out the movable latch at the front case with hand, disassemble the front case.

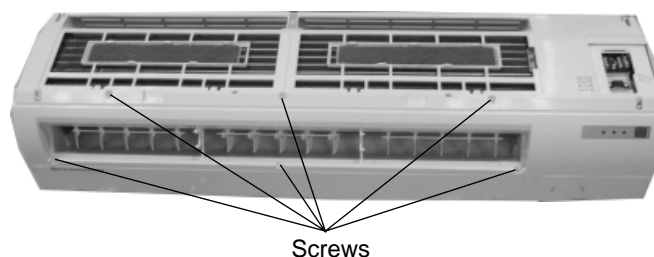

Operating Procedures / Photos

4. Disassemble the electric cover

Press the clasps in by till they loose, then lift up wards the electric cover.

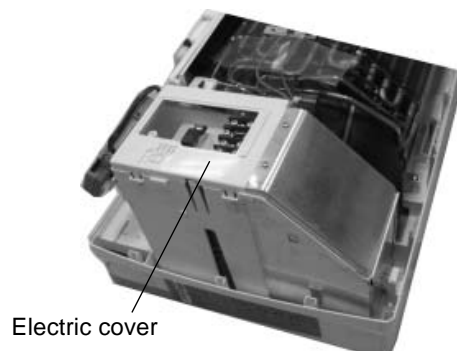

5. Disassemble the electric box

Loosen the grounding wire of the evaporator, remove the temperature sensor for the pipe, put out the connection lines of the step motor and the indoor motor. Screw off the screw fixing the electric box. Remove the electric box.

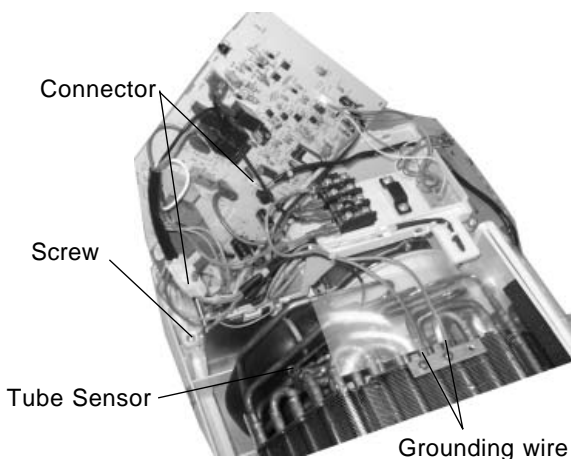

5. Disassemble water tray

Loosen the clasps on both side of water tray and lift it upward, then can take off the water tray sub-assy.

Note: Due to the water tray is connected with the water pipe, please be careful to take out the water tray, do not collapse the fin on evaporator.



Operating Procedures / Photos

6. Disassembling the evaporator

Screw off 2 screws fixing the pipe clamp, loosen the clasp on the other side, can remove the pipe clamp.

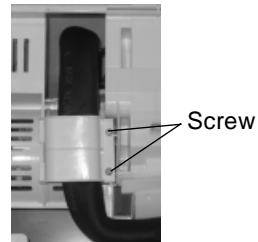

CAUTION:

When repair, Carefully take out the evaporator and pay attention to protect the connecting pipe.

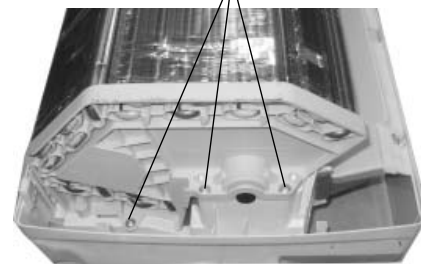

7. Disassembling motor and cross flow fan

Screw off 4 screws fixing the evaporator support (right) and the motor clamp, screw off the holding screw at the left shaft sleeve of the cross flow fan, pull out the motor, and remove the cross flow fan.

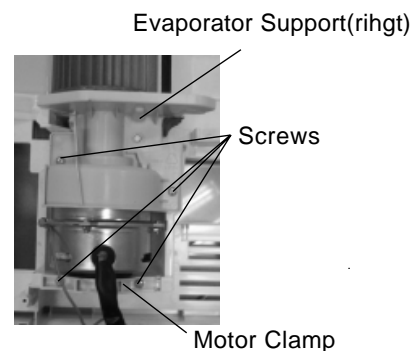

7.2 Disassembly Procedures for Outdoor Unit

Operating Procedures / Photos

1. Disassemble Top Cover and Front Side Plate

Unscrew the screws fixing the top cover, and then lift the top cover to remove it.
Unscrew the 3 screws fixing the front side plate to remove it.

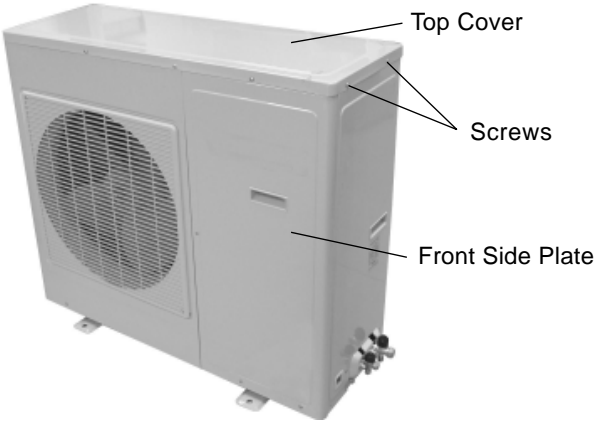

2. Disassemble Rear Grill

Unscrew the 4 screws fixing the rear grill to remove it.



3. Disassemble Cabinet

Unscrew the screws fixing the cabinet to remove it.

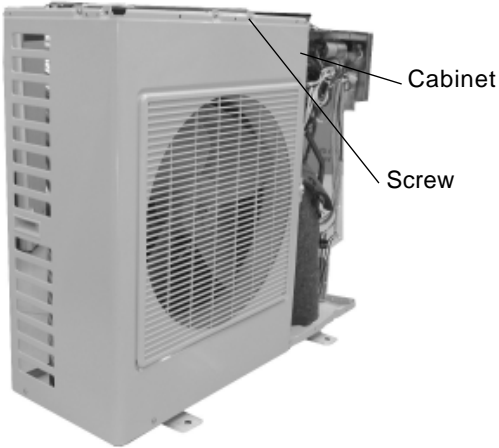

Operating Procedures / Photos

4. Disassemble Electric Box Sub-assy

Unscrew the 2 screws fixing electric box to pull out the connection line between fan motor, compressor, four-way valve, and then lift the electric box to take it out.

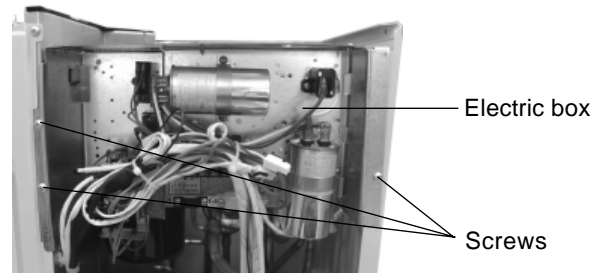

5. Disassemble Right side plate

Unscrew the screw of the right side plate, then take down the right side plate.

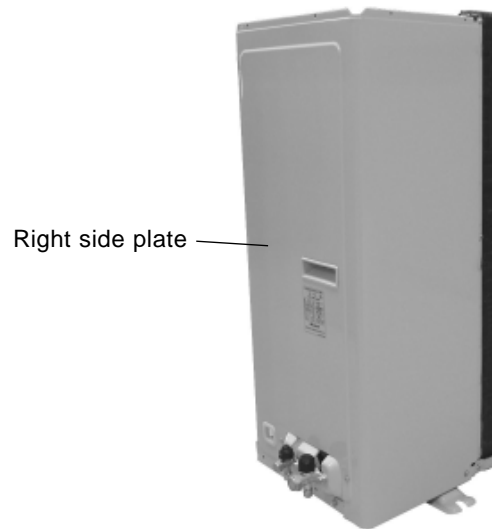

6. Disassemble Gas and Liquid Valves

Unsolder the pipeline connecting with valves (to prevent soldering gun from burning out the chassis). Unscrew 2 bolts fixing gas valve ,and then unsolder the weld spot between pipeline and gas valve to remove gas valve. Unscrew the 2 bolts fixing liquid valve, and then unsolder the soldering spot between pipeline and liquid valve to remove liquid valve.

(Note:During unsoldering ,wrap the valves with wet cloth avoid damage for high temperature.)

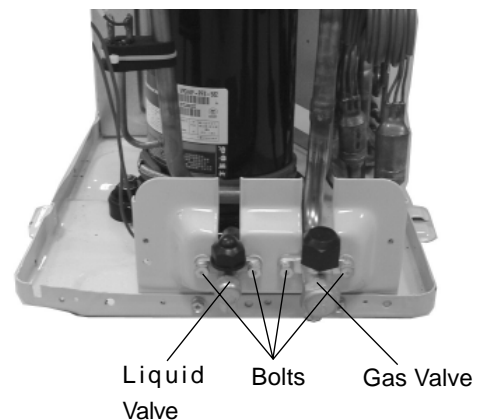

Operating Procedures / Photos

7. Disassemble Axial Flow Fan

Unscrew the nut fixing the fan with a spanner to take out the fan.

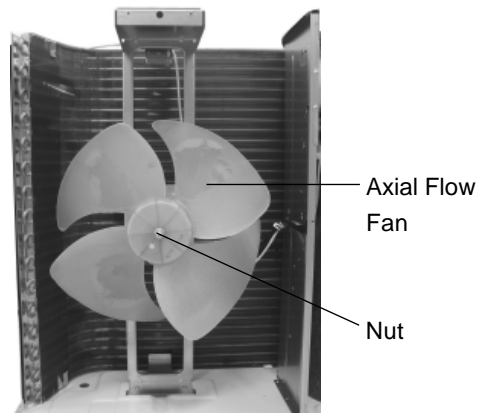

8. Disassemble Outdoor Motor

Unscrew the screws fixing the motor support, and then lift it upwards to remove it. Unscrew the screws fixing the motor and pull out the connection line between it and electric box to remove it.

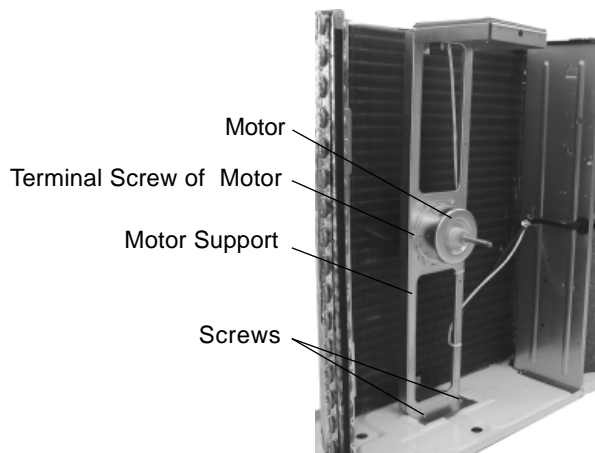

9. Disassemble Four-way Valve

Only for cooling and heating unit
 Unscrew the fixing nut of the four-way valve coil and remove the coil. Wrap the four-way valve with wet cotton and unsolder the 4 weld spots connecting the four-way valve to take it out. Welding process should be as quick as possible and keep wrapping cotton wet all the time. Be sure not to burn out the lead-out wire of compressor.

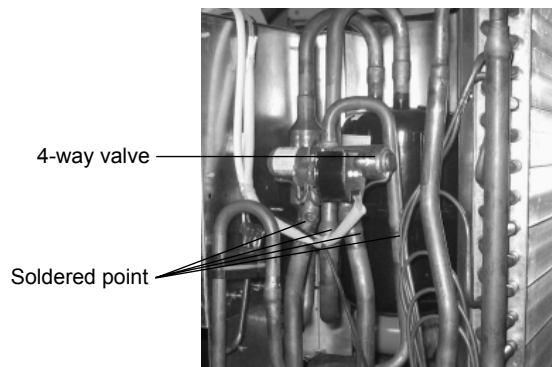

Operating Procedures / Photos

10. Disassemble Capillary

Unsolder the weld spots of capillary, valve and outlet tube of condenser to remove the capillary. Prevent welding slag from blocking the capillary.



11. Disassemble Compressor

Unsolder the pipeline connecting the compressor, and then unscrew the 3 foot-nuts fixing compressor to remove it.

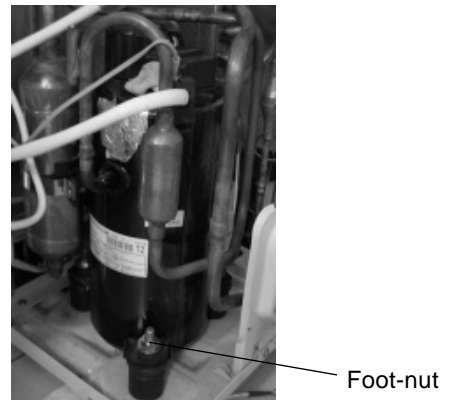

8 Explosive view and spare parts list

8.1 Exploded View of Components and Parts of Indoor unit

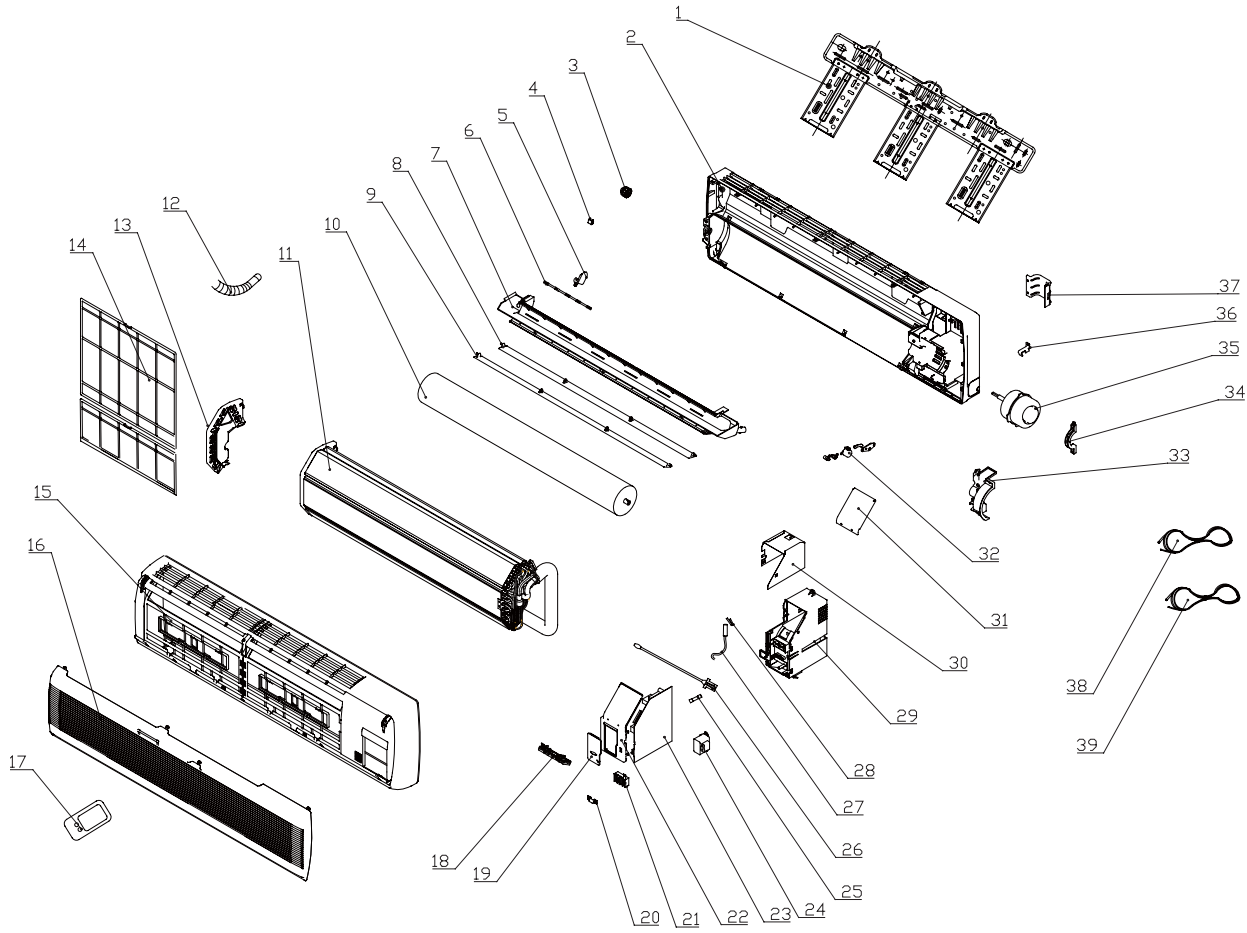

No	Description	Part Code		Qty
		GWHN24FANK3A1B/I	GWHN24FANK3A1A/I	
1	Wall-Mounting Frame	01252398	01252398	1
2	Rear Case	22202091	22202091	1
3	Fan Bearing	76512203	76512203	1
4	Screw Cover	242520053	242520053	3
5	Swing Louver	10512110	10512110	15
6	Swing Link	10582040	10582040	3
7	Water Tray	20182043	20182043	1
8	Guide Louver (up)	10512062	10512062	1
9	Guide Louver (down)	10512063	10512063	1
10	Cross Flow Fan	10352420	10352420	1
11	Evaporator Assy	01002527	01002527	1
12	Drainage Pipe	0523001401	0523001401	1
13	Evaporator Support (left)	24212041	24212041	1
14	Filter	11122051	11122051	2
15	Front Case	20002923	20002923	1
16	Front Panel	20002375	20002375	1
17	Remote Controller YT1F	30510049	30510049	1
18	Receiver Board JD	30042029	30042029	1
19	Electric Box Cover	20102252	20102252	1
20	Wire Clamp	71010103	71010103	1
21	Terminal Board T4B3A	42011233	42011233	1
22	Electric Box Cover	20112044S	20112044S	1
23	Main PCB	30135138	30135138	1
24	Transformer 41X26.5G	43110236	43110236	1
25	Fuse T5AL 250V	46010013	46010013	1
26	Room Sensor	390000451	390000451	1
27	Tube Sensor	390000591	390000591	1
28	Sensor Insert	42020063	42020063	1
29	Electric Box	20102250	20102250	1
30	Lower Shield of Electric Box	01592034	01592034	1
31	Upper Shield of Electric Box	01592033	01592033	1
32	Stepping Motor MP24GA	15212102	15212102	1
33	Evaporator Support (rihgt)	24212042	24212042	1
34	Motor Clamp	26112069	26112069	1
35	Motor FN30D	150121052	150121052	1
36	Fixer(evaporator)	02112009	02112009	1
37	Pipe Clamp	26112071	26112071	1
38	Connecting Cable	400205235	400205235	1
39	Power Cable	400205405	400205405	1

The above data are subject to be changed without notice.

No	Description	Part Code	Qty
		GWHN28FANK3A1A/I	
1	Wall-Mounting Frame	01252398	1
2	Rear Case	22202091	1
3	Fan Bearing	76512203	1
4	Screw Cover	242520053	3
5	Swing Louver	10512110	15
6	Swing Link	10582040	3
7	Water Tray	20182043	1
8	Guide Louver (up)	10512062	1
9	Guide Louver (down)	10512063	1
10	Cross Flow Fan	10352420	1
11	Evaporator Assy	01002527	1
12	Drainage Pipe	0523001401	1
13	Evaporator Support (left)	24212041	1
14	Filter	11122051	2
15	Front Case	20002923	1
16	Front Panel	20002375	1
17	Remote Controller YT1F	30510049	1
18	Receiver Board JD	30042029	1
19	Electric Box Cover	20102252	1
20	Wire Clamp	71010103	1
21	Terminal Board T4B3A	42011233	1
22	Electric Box Cover	20112044S	1
23	Main PCB	30135138	1
24	Transformer 41X26.5G	43110236	1
25	Fuse T5AL 250V	46010013	1
26	Room Sensor	390000451	1
27	Tube Sensor	390000591	1
28	Sensor Insert	42020063	1
29	Electric Box	20102250	1
30	Lower Shield of Electric Box	01592034	1
31	Upper Shield of Electric Box	01592033	1
32	Stepping Motor MP24GA	15212102	1
33	Evaporator Support (rihgt)	24212042	1
34	Motor Clamp	26112069	1
35	Motor FN30D	150121052	1
36	Fixer(evaporator)	02112009	1
37	Pipe Clamp	26112071	1
38	Connecting Cable	400205235	1
39	Power Cable	400205405	1

The above data are subject to be changed without notice.

8.2 Exploded View of Components and Parts of outdoor unit

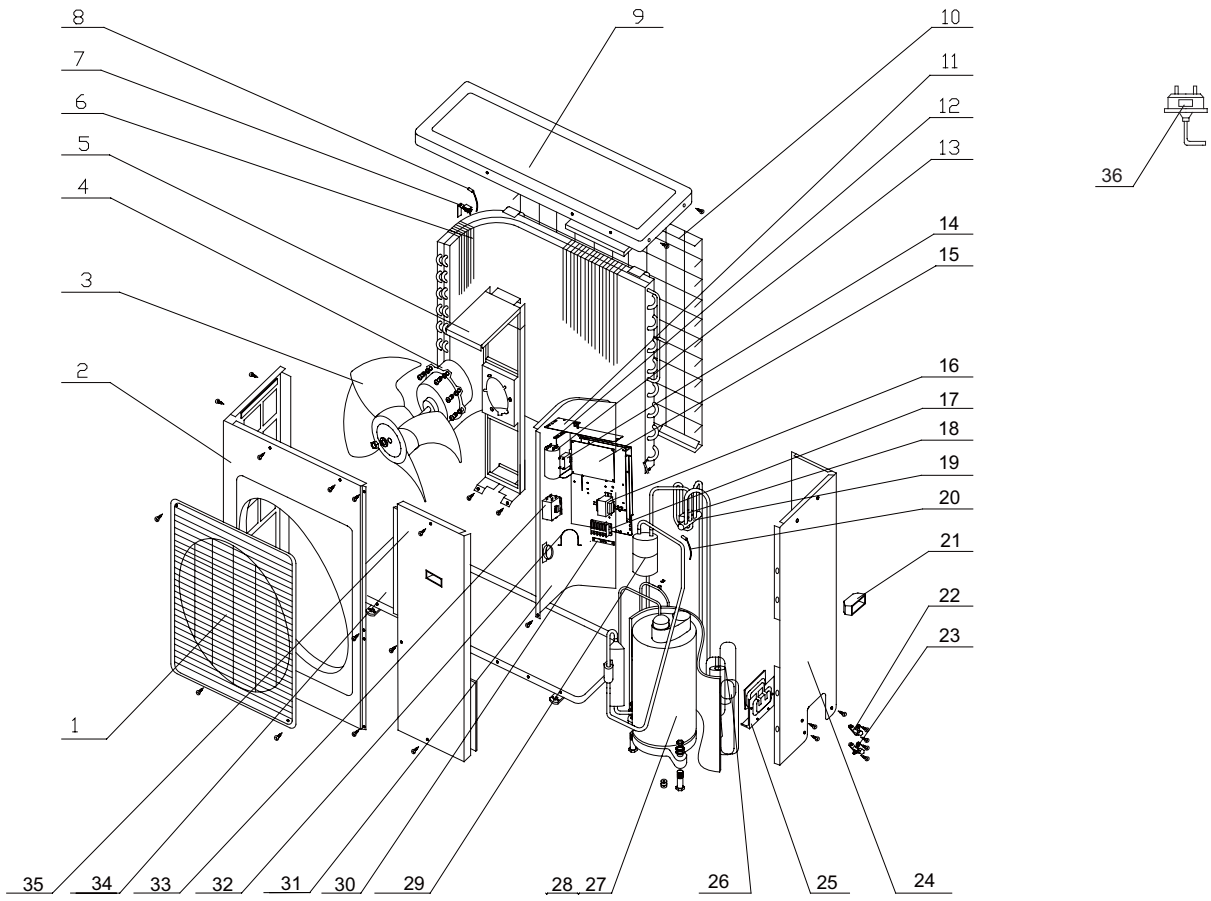

No	Description	Part Code		Qty
		GWHN24FANK3A1B/O	GWHN24FANK3A1A/O	
1	Front Grill	22265251	01473001	1
2	Front Plate	01433031	01433011	1
3	Axial Flow Fan	10335257	10335253	1
4	Motor FW68B	15015057	5013106	1
5	Motor Support	01703025	01705253	1
6	Condenser Assy	01103970	01103842	1
7	Temp Sensor Support	24211121	24215101	1
8	Ambient Sensor	390002063	390002064	1
9	Top Cover	01255262	01255262	1
10	Rear Grill	01473028	01475252	1
11	upper Electric box cover	01413076	01413076	1
12	Electric Plate	01403377	01403377	1
13	Capacitor CBB65 60uF/450V	33000039	33000039	1
14	Capacitor CBB61 3.5uF/450V	33010010	33010010	1
15	Main PCB	30135142	30135142	1
16	Transformer 41X26.5G	43110236	43110236	1
17	Terminal Board	42010258	42010258	1
18	4-way Valve Coil	430004005	430004002	1
19	4-way Valve	430004032	43000411	1
20	Temp Sensor	3900012121	390001921	1
21	Handle	26235253	26235253	1
22	Gas Valve Assy 5/8"	07103030	07103030	1
23	Liquid Valve Assy 3/8"	07130209	07130209	1
24	Rear Side Plate	01305036	01303709	1
25	Valve Support	01715256	01715256	1
26	Capillary Assy	03003793	03103372	1
27	CompressorATH290CV-C9LU	00103709	00103080	1
28	Overload Protector	Inset	Inset	1
29	Gas-liquid Separator	/	07255251	1
30	Isolation Washer C	70410523	70410523	1
31	Clapboard	01233024	01233019	1
32	Capacitor Clamp	02141005	02141005	1
33	AC Contactor CJX9B-25S/D	44010245	44010245	1
34	Metal Base	01203654P	01203628P	1
35	Front Side Plate	01303023	01305247	1
36	Pressure Switch	460200061	460200061	1

The above data are subject to be changed without notice.

No	Description	Part Code	Qty
		GWHN28FANK3A1A/O	
1	Front Grill	01473001	1
2	Front Plate	01433011	1
3	Axial Flow Fan	10335253	1
4	Motor LW80C	15013106	1
5	Motor Support	01705253	1
6	Condenser Assy	01103842	1
7	Temp Sensor Support	24215101	1
8	Ambient Sensor	390002064	1
9	Top Cover	01255262	1
10	Rear Grill	01475252	1
11	upper Electric box cover	01413076	1
12	Electric Plate	01403377	1
13	Capacitor CBB65 60uF/450V	33000039	1
14	Capacitor CBB61 3.5uF/450V	33010010	1
15	Main PCB	30135142	1
16	Transformer 41X26.5G	43110236	1
17	Terminal Board	42010258	1
18	4-way Valve Coil	430004002	1
19	4-way Valve	43000411	1
20	Temp Sensor	390001921	1
21	Handle	26235253	1
22	Gas Valve Assy 5/8"	07103030	1
23	Liquid Valve Assy 3/8"	07130209	1
24	Rear Side Plate	01303709	1
25	Valve Support	01715256	1
26	Capillary Assy	03103372	1
27	Compressor 5VS270EAA21	00103080	1
28	Overload Protector	Inset	1
29	Gas-liquid Separator	07255251	1
30	Isolation Washer C	70410523	1
31	Clapboard	01233019	1
32	Capacitor Clamp	02141005	1
33	AC Contactor CJX9B-25S/D	44010245	1
34	Metal Base	01203628P	1
35	Front Side Plate	01305247	1
36	Pressure Switch	460200061	1

The above data are subject to be changed without notice.

9 Failure and analysis

Note: When replacing the controller, make sure insert the wire jumper into the new controller, otherwise the unit display C5

