

Service Manual

Models: GWH07QA-K3DNA2C
GWH07QA-K3DNA5C
GWH07QA-K3DNA6C
GWH07QA-K3DNB2C
GWH07QA-K3DNB4C
GWH07QA-K3DNB6C
GWH07QA-K3DNB8C
GWH07QA-K3DNC4C
(Refrigerant:R410A)

Table of Contents

Part I : Technical Information	1
1. Summary	1
2. Specifications	2
2.1 Specification Sheet.....	2
2.2 Operation Characteristic Curve.....	4
2.3 Capacity Variation Ratio According to Temperature.....	4
2.4 Cooling and Heating Data Sheet in Rated Frequency.....	5
2.5 Noise Curve.....	5
3. Outline Dimension Diagram	6
3.1 Indoor Unit.....	6
3.2 Outdoor Unit.....	7
4. Refrigerant System Diagram	8
5. Electrical Part	9
5.1 Wiring Diagram.....	9
5.2 PCB Printed Diagram.....	11
6. Function and Control	13
6.1 Remote Controller Introduction.....	13
6.2 Brief Description of Modes and Functions.....	16
Part II : Installation and Maintenance	21
7. Notes for Installation and Maintenance	21
8. Installation	23
8.1 Installation Dimension Diagram.....	23
8.2 Installation Parts-checking.....	25
8.3 Selection of Installation Location.....	25
8.4 Electric Connection Requirement.....	25
8.5 Installation of Indoor Unit.....	25
8.6 Installation of Outdoor Unit.....	28
8.7 Vacuum Pumping and Leak Detection.....	29
8.8 Check after Installation and Test Operation.....	29

- 9. Maintenance**30
 - 9.1 Malfunction Analysis30
 - 9.2 Flashing LED of Indoor/Outdoor Unit and Primary Judgement34
 - 9.3 How to Check Simply the Main Part43
- 10. Exploded View and Parts List**56
 - 10.1 Indoor Unit56
 - 10.2 Outdoor Unit62
- 11. Removal Procedure**64
 - 11.1 Removal Procedure of Indoor Unit64
 - 11.2 Removal Procedure of Outdoor Unit69
- Appendix:**74
 - Appendix 1: Reference Sheet of Celsius and Fahrenheit74
 - Appendix 2: Configuration of Connection Pipe74
 - Appendix 3: Pipe Expanding Method75
 - Appendix 4: List of Resistance for Temperature Sensor76

Part I : Technical Information

1. Summary

Indoor Unit:

A2 Panel

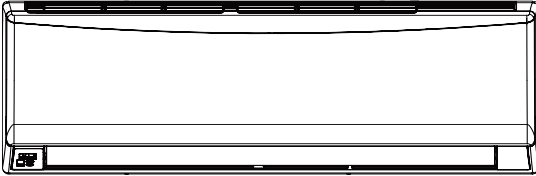

A6 Panel



B4 Panel

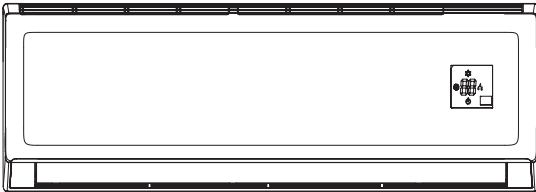

B8 Panel

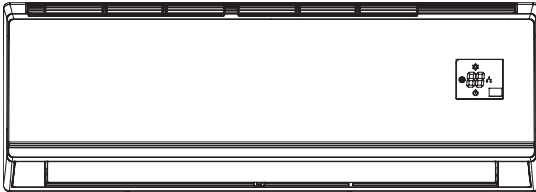

A5 Panel

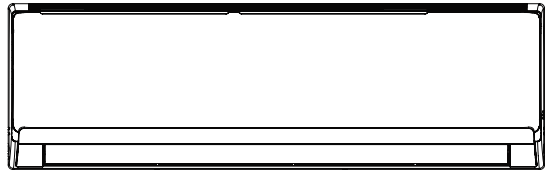

B2 Panel

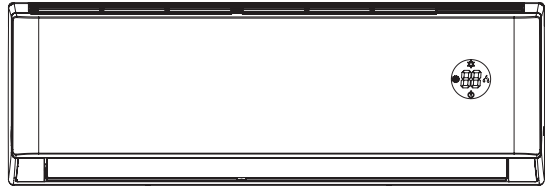

B6 Panel



C4 Panel

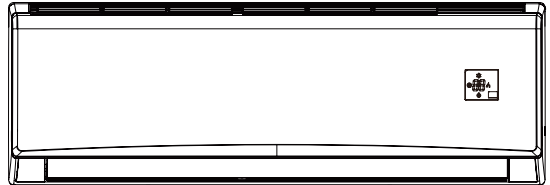

Outdoor Unit:

GWH07QA-K3DNA5C/O

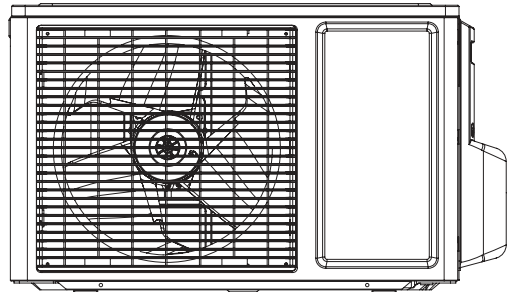

Remote Controller:

YX1F



2. Specifications

2.1 Specification Sheet

Model			1.GWH07QA-K3DNA2C 2.GWH07QA-K3DNA5C 3.GWH07QA-K3DNA6C 4.GWH07QA-K3DNB2C 5.GWH07QA-K3DNB4C 6.GWH07QA-K3DNB6C 7.GWH07QA-K3DNB8C 8.GWH07QA-K3DNC4C	
Product Code			1.CB426004500 2.CB425005400 /CB425005401 3.CB427006600 4.CB432006200 5.CB434004700 6.CB435005500 7.CB438004200 8.CB444003000	
Power Supply	Rated Voltage	V~	220-240	
	Rated Frequency	Hz	50	
	Phases		1	
Power Supply Mode			Outdoor	
Cooling Capacity		W	2200	
Heating Capacity		W	2300	
Cooling Power Input		W	685	
Heating Power Input		W	637	
Cooling Current Input		A	3.6	
Heating Current Input		A	3.5	
Rated Input		W	1400	
Rated Current		A	6.7	
Air Flow Volume(SH/H/M/L/SL)		m ³ /h	500/420/390/300/-	
Dehumidifying Volume		L/h	0.8	
EER		W/W	3.21	
COP		W/W	3.61	
SEER			5.1	
HSPF			/	
Application Area		m ²	12-18	
Indoor Unit	Indoor Unit Model		1.GWH07QA-K3DNA2C/I 2.GWH07QA-K3DNA5C/I 3.GWH07QA-K3DNA6C/I 4.GWH07QA-K3DNB2C/I 5.GWH07QA-K3DNB4C/I 6.GWH07QA-K3DNB6C/I 7.GWH07QA-K3DNB8C/I 8.GWH07QA-K3DNC4C/I	
	Indoor Unit Product Code		1.CB426N04500 2.CB425N05400/CB425N05401 3.CB427N06600 4.CB432N06200 5.CB434N04700 6.CB435N05500 7.CB438N04200 8.CB444N03000	
	Fan Type		Cross-flow	
	Fan Diameter Length(DXL)		mm	Φ98X507
	Cooling Speed(SH/H/M/L/SL)		r/min	1300/1200/1000/800/-
	Heating Speed(SH/H/M/L/SL)		r/min	1300/1200/1000/900/-
	Fan Motor Power Output		W	10
	Fan Motor RLA		A	0.215
	Fan Motor Capacitor		μF	1
	Evaporator Form			Aluminum Fin-copper Tube
	Evaporator Pipe Diameter		mm	Φ5
	Evaporator Row-fin Gap		mm	2-1.4
	Evaporator Coil Length(LXDXW)		mm	584X22.8X266.7
	Swing Motor Model			MP24AA
	Swing Motor Power Output		W	1.5
	Fuse Current		A	3.15
	Sound Pressure Level(SH/H/M/L/SL)		dB (A)	40/36/34/29/-
	Sound Power Level(SH/H/M/L/SL)		dB (A)	52/47/44/39/-
	Dimension(WXHXD)		mm	713X270X195
	Dimension of Carton Box(LXWXH)		mm	773X265X347
Dimension of Package(LXWXH)		mm	776X268X362	
Net Weight		kg	8.5	
Gross Weight		kg	10	

Outdoor Unit	Model of Outdoor Unit		GWH07QA-K3DNA5C/O
	Product Code of Outdoor Unit		CB425W05400
	Compressor Manufacturer/Trademark		Shanghai Hitachi Electrical Appliances Co.,Ltd
	Compressor Model		ASA725SPMA6JK
	Compressor Oil		A68HES-H or equivaquent 260±20ml
	Compressor Type		Rotary
	L.R.A.	A	14.50
	Compressor RLA	A	2.71
	Compressor Power Input	W	582
	Overload Protector		/
	Throttling Method		Capillary
	Operation temp	°C	16~30
	Ambient temp (cooling)	°C	-15~48
	Ambient temp (heating)	°C	-22~24
	Condenser Form		Aluminum Fin-copper Tube
	Pipe Diameter	mm	Φ7.94
	Rows-fin Gap	mm	1-1.4
	Coil Length (LXDXW)	mm	647X12.7X400
	Fan Motor Speed	rpm	900
	Output of Fan Motor	W	30
	Fan Motor RLA	A	0.4
	Fan Motor Capacitor	μF	/
	Air Flow Volume of Outdoor Unit	m ³ /h	1200
	Fan Type		Axial-flow
	Fan Diameter	mm	Φ320
	Defrosting Method		Automatic Defrosting
	Climate Type		T1
	Isolation		I
	Moisture Protection		IPX4
	Permissible Excessive Operating Pressure for the Discharge Side	MPa	4.3
	Permissible Excessive Operating Pressure for the Suction Side	MPa	2.5
	Sound Pressure Level (H/M/L)	dB (A)	51/-/-
	Sound Power Level (H/M/L)	dB (A)	60/-/-
Dimension (WXHXD)	mm	720X428X310	
Dimension of Carton Box (LXWXH)	mm	765X350X475	
Dimension of Package (LXWXH)	mm	768X353X490	
Net Weight	kg	21.5	
Gross Weight	kg	23.5	
Refrigerant		R410A	
Refrigerant Charge	kg	0.55	
Connection Pipe	Length	m	5
	Gas Additional Charge	g/m	20
	Outer Diameter Liquid Pipe	mm	Φ6
	Outer Diameter Gas Pipe	mm	Φ9.52
	Max Distance Height	m	10
	Max Distance Length	m	15
Note: The connection pipe applies metric diameter.			

The above data is subject to change without notice; please refer to the nameplate of the unit.

2.2 Operation Characteristic Curve

Cooling

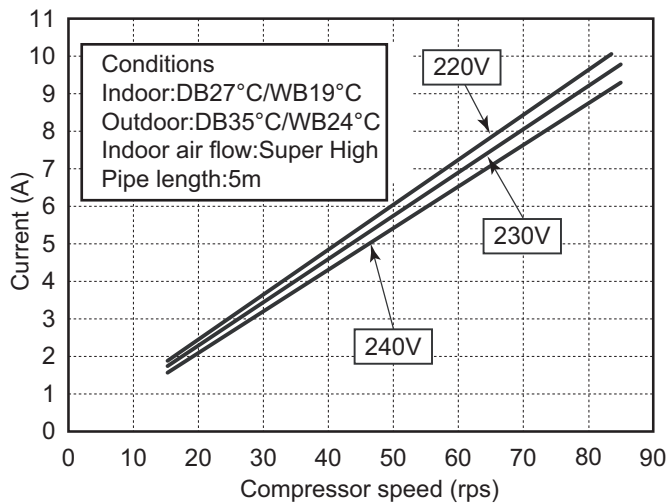

Heating

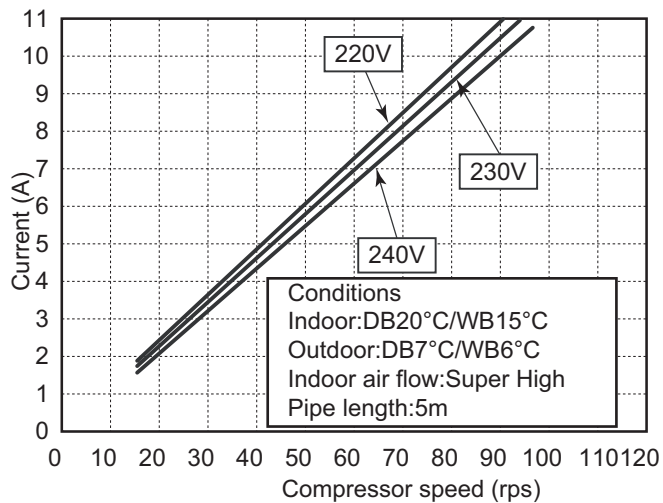

2.3 Capacity Variation Ratio According to Temperature

Cooling

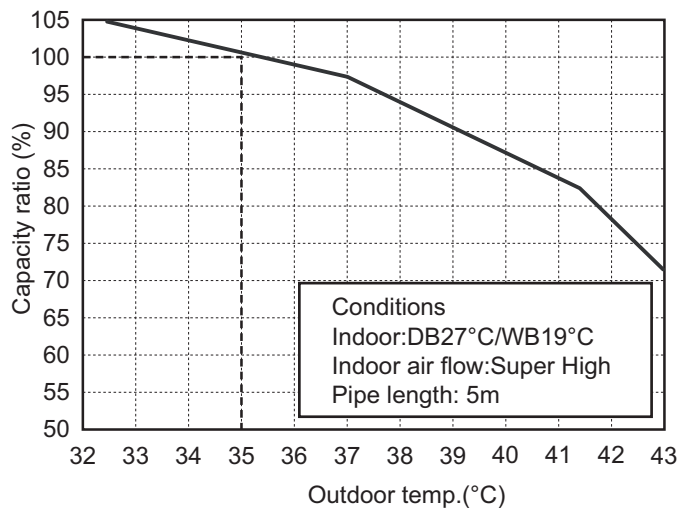

Heating

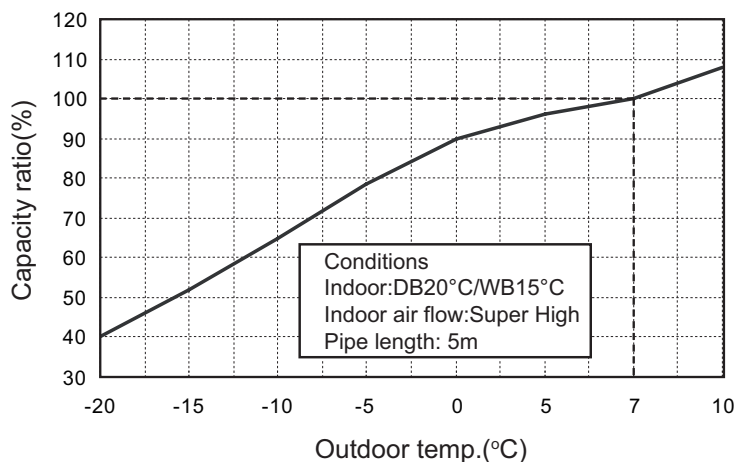

2.4 Cooling and Heating Data Sheet in Rated Frequency

Cooling:

Rated cooling condition(°C) (DB/WB)		Model	Pressure of gas pipe connecting indoor and outdoor unit	Inlet and outlet pipe temperature of heat exchanger		Fan speed of indoor unit	Fan speed of outdoor unit
Indoor	Outdoor			T1 (°C)	T2 (°C)		
27/19	35/24	07K	0.8 ~ 1.1	11 to 14	38 to 41	Super High	High

Heating:

Rated heating condition(°C) (DB/WB)		Model	Pressure of gas pipe connecting indoor and outdoor unit	Inlet and outlet pipe temperature of heat exchanger		Fan speed of indoor unit	Fan speed of outdoor unit
Indoor	Outdoor			T1 (°C)	T2 (°C)		
20/15	7/6	07K	2.8 ~ 3.2	38 to 41	2 to 5	Super High	High

Instruction:

T1: Inlet and outlet pipe temperature of evaporator

T2: Inlet and outlet pipe temperature of condenser

P: Pressure at the side of big valve

Connection pipe length: 5m.

2.5 Noise Curve

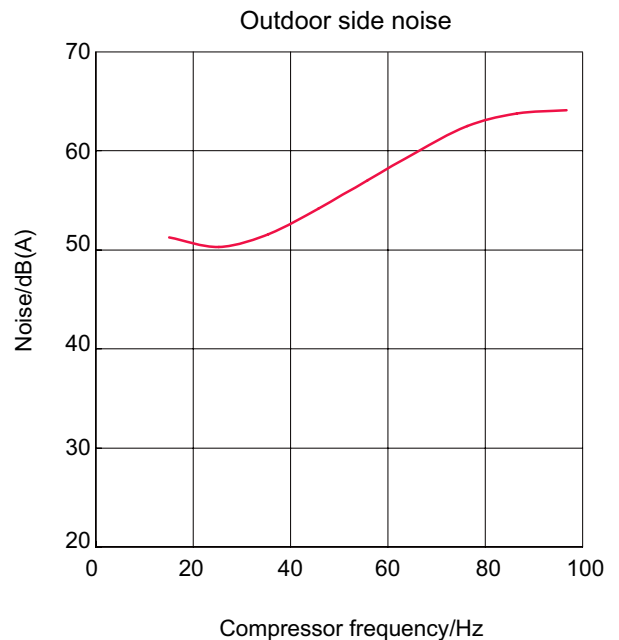
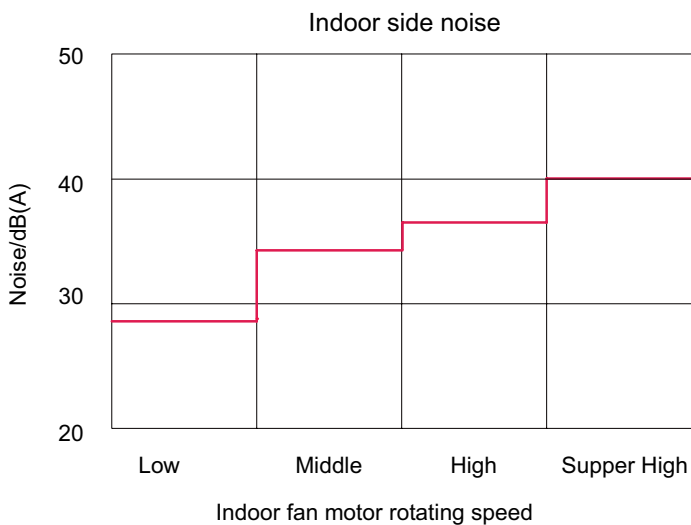

3. Outline Dimension Diagram

3.1 Indoor Unit

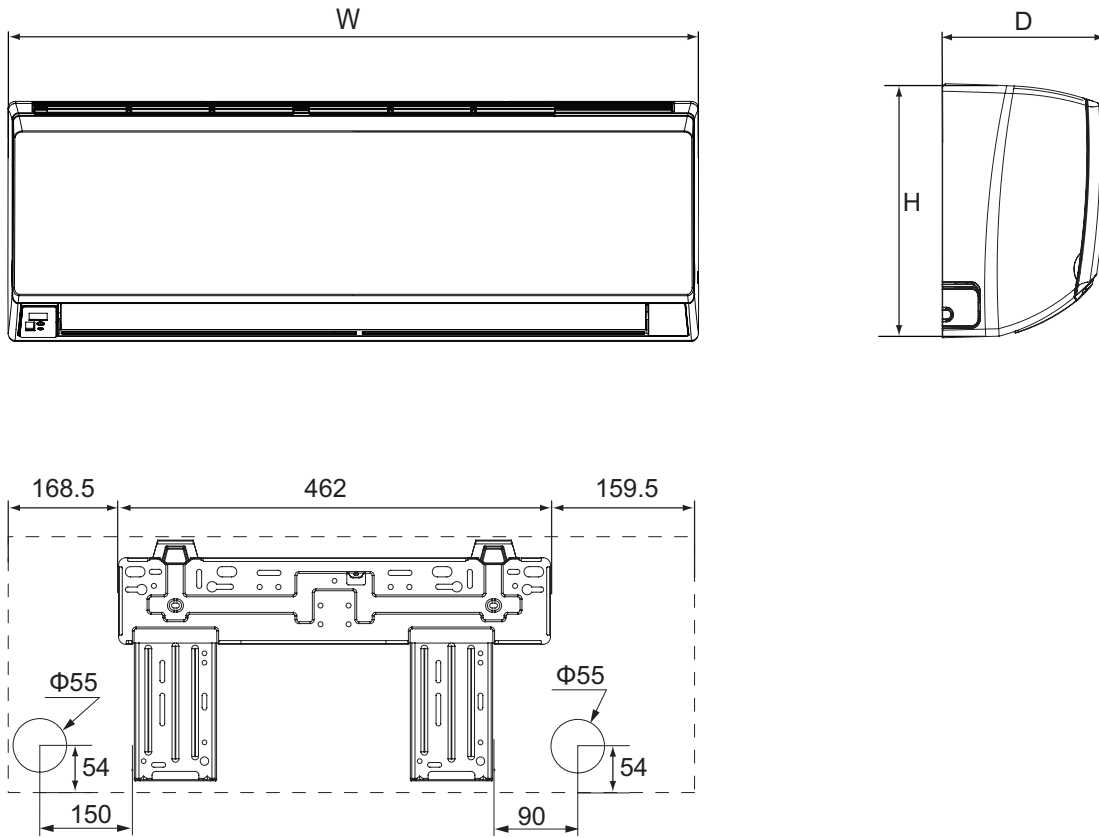

Unit:mm

Models	W	H	D
07K	790	275	200

4. Refrigerant System Diagram

Cooling and heating model

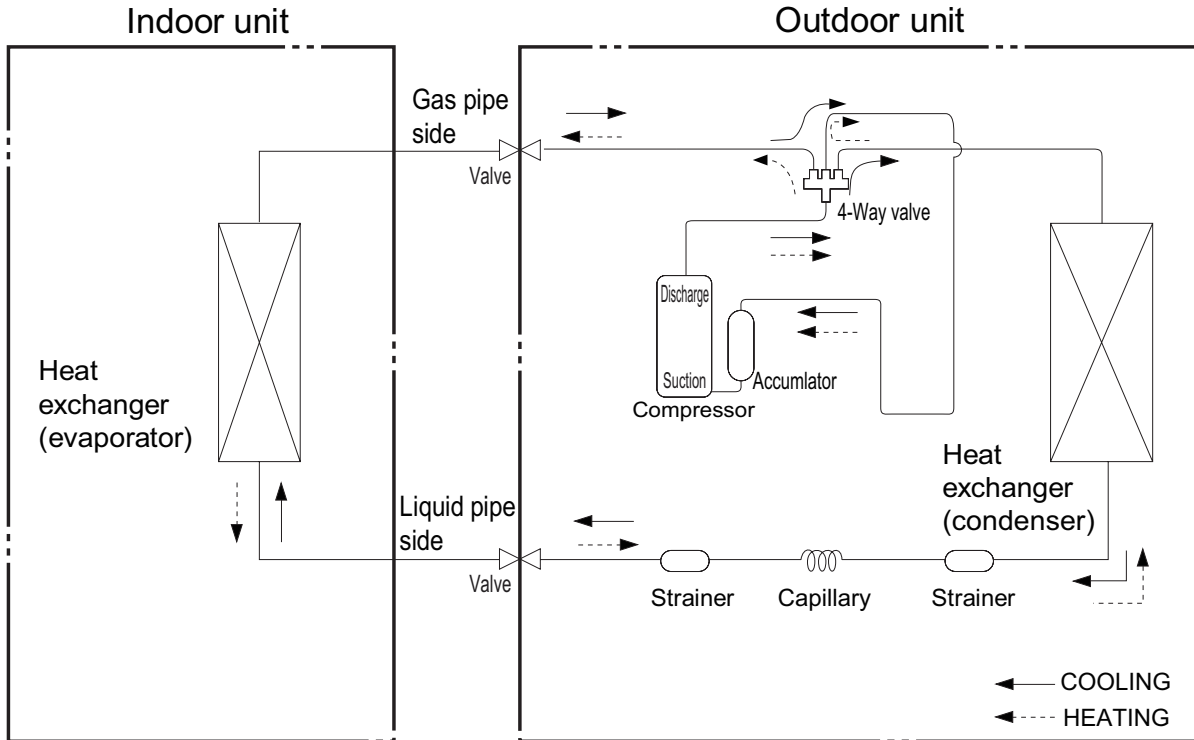

Connection pipe specification:
 Liquid pipe: 1/4" (6mm)
 Gas pipe: 3/8" (9.52mm)

5. Electrical Part

5.1 Wiring Diagram

• Instruction

Symbol	Symbol Color	Symbol	Symbol Color	Symbol	Name
WH	White	GN	Green	CAP	Jumper cap
YE	Yellow	BN	Brown	COMP	Compressor
RD	Red	BU	Blue	⊕	Grounding wire
YEGN	Yellow/Green	BK	Black	/	/
VT	Violet	OG	Orange	/	/

Note: Jumper cap is used to determine fan speed and the swing angle of horizontal lover for this model.

• Indoor Unit

GWH07QA-K3DNA2C/I GWH07QA-K3DNA5C/(CB425N05400) GWH07QA-K3DNB2C/I GWH07QA-K3DNB4C/I
GWH07QA-K3DNB6C/I GWH07QA-K3DNC4C/I

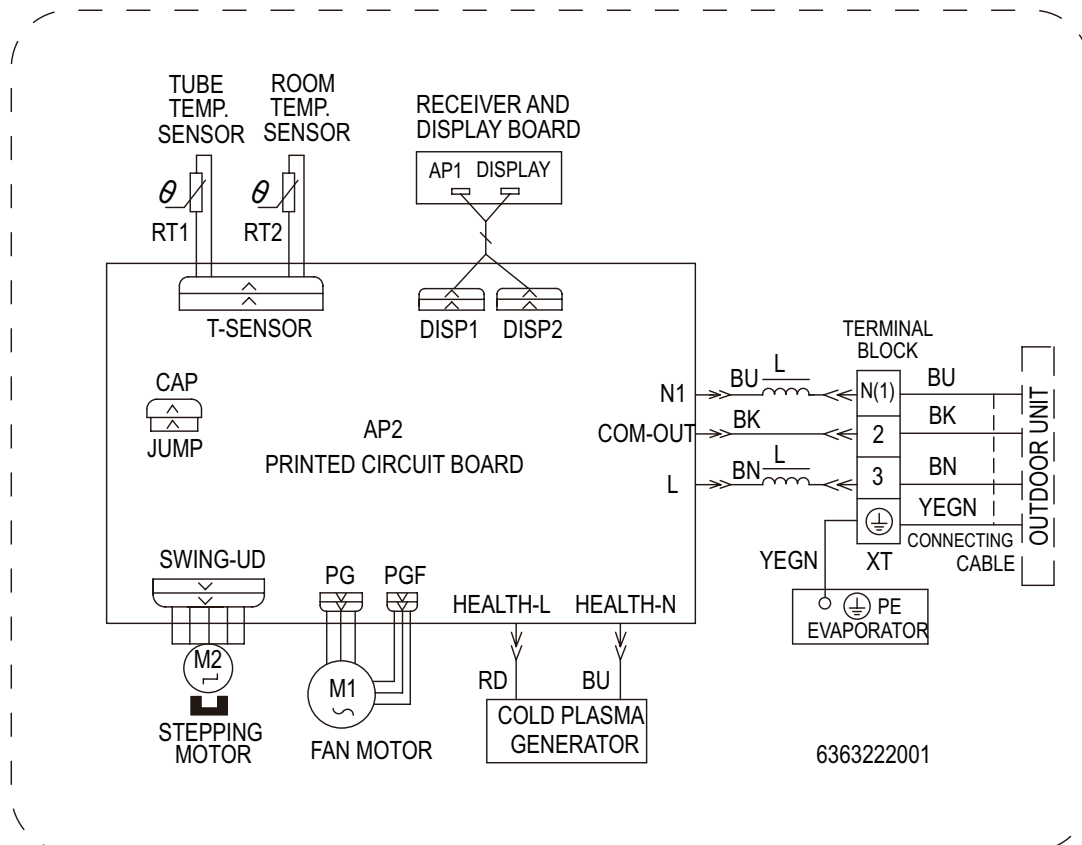

GWH07QA-K3DNA5C/I(CB425N05401) GWH07QA-K3DNA6C/I

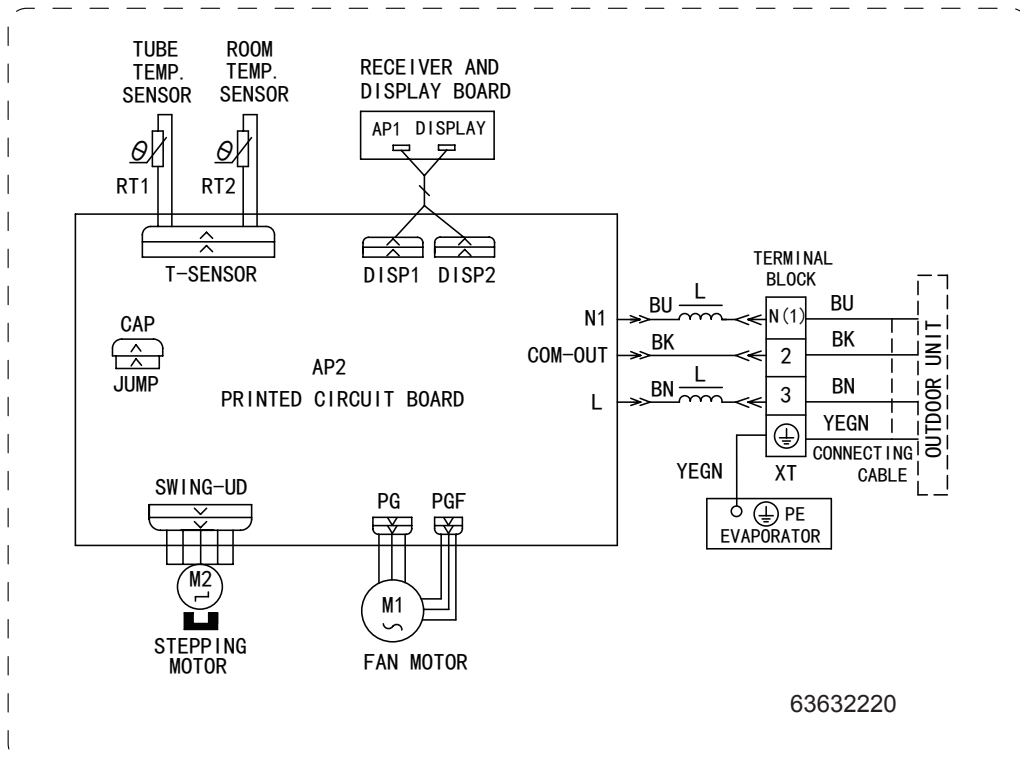

• Outdoor Unit

GWH07QA-K3DNA5C/O

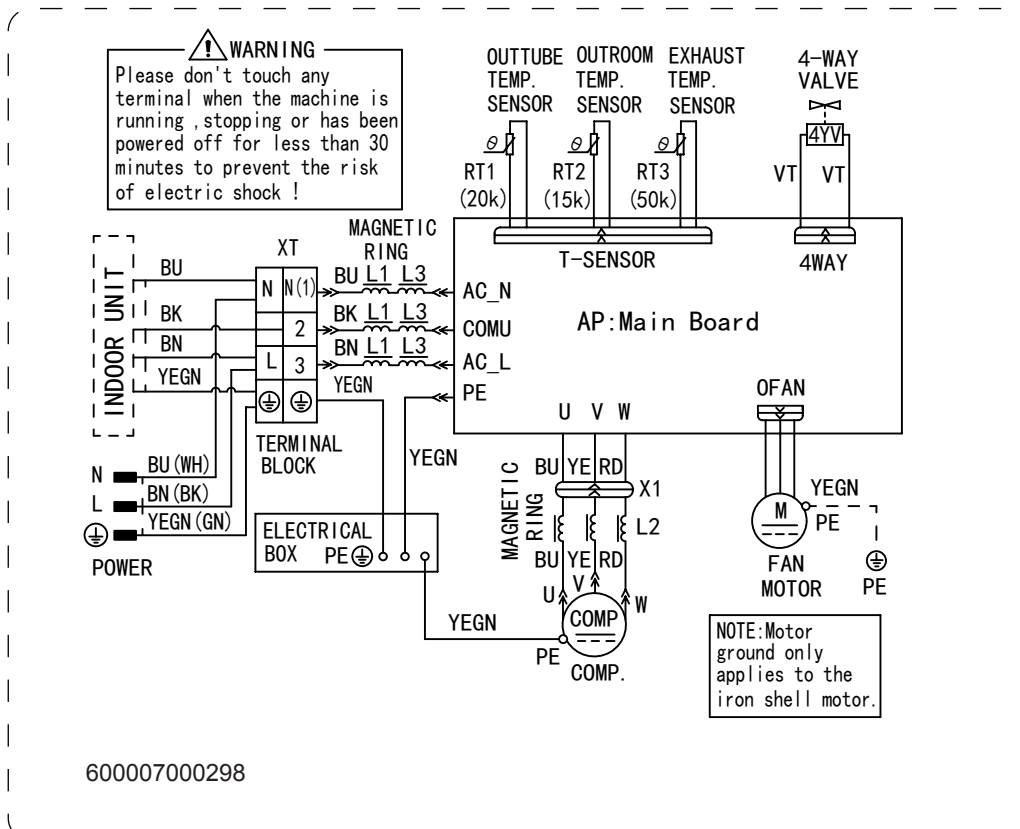

These wiring diagrams are subject to change without notice; please refer to the one supplied with the unit.

5.2 PCB Printed Diagram

Indoor Unit

● Top view

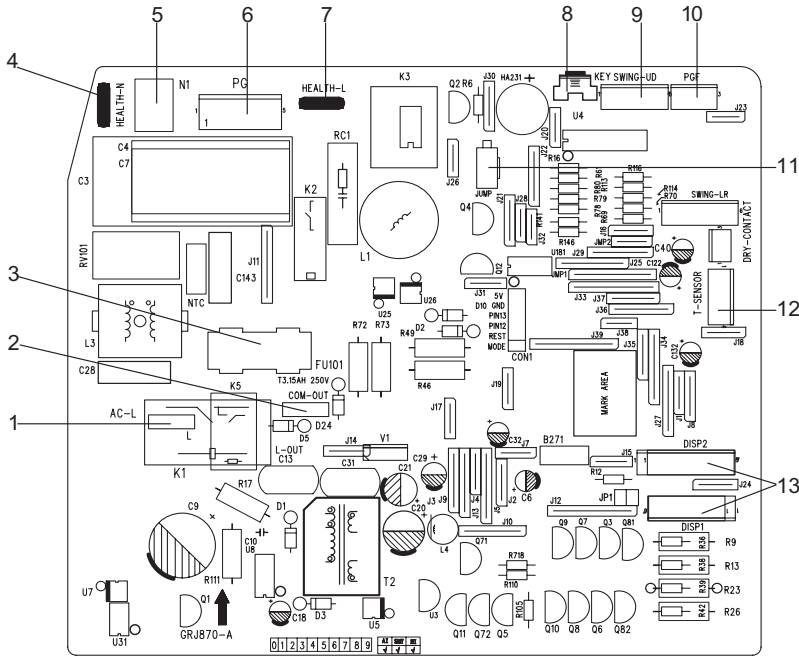

No.	Name
1	Livewire
2	Terminal with indoor unit communication wire
3	Fuse
4	Interface of health function neutral wire(only for the mode with this function)
5	Neutral wire
6	Interface of indoor fan
7	Live wire interface of cold plasma (only for the mode with this function)
8	Auto button
9	Interface of up & down swing motor
10	Interface of indoor fan feedback
11	Jumper cap
12	Temperature sensor interface
13	Interface of display

● Bottom view

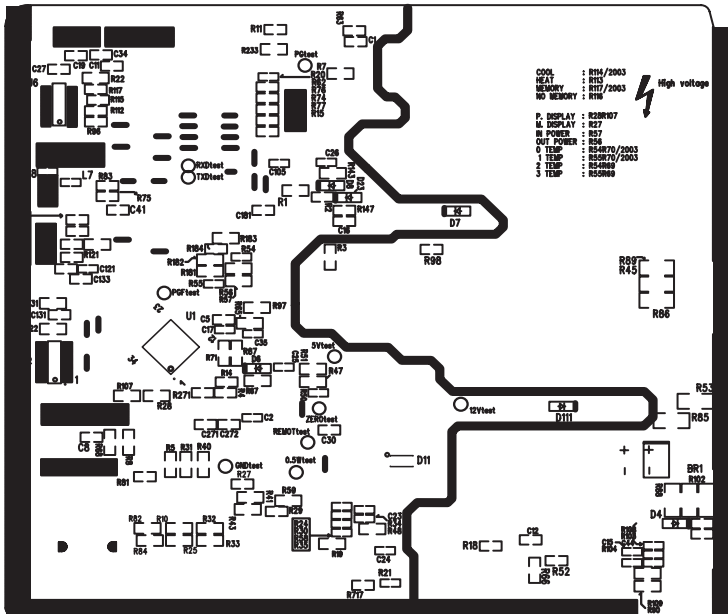

6. Function and Control

6.1 Remote Controller Introduction

Buttons on Remote Controller

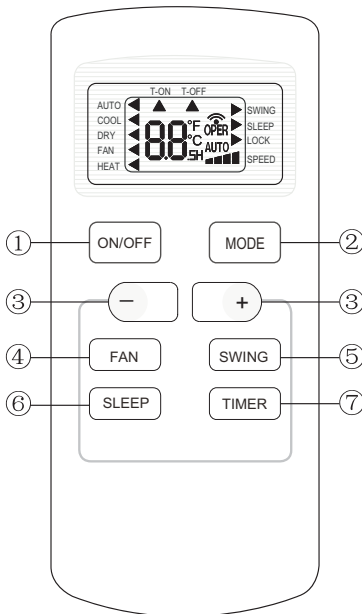

①: ON/OFF button

②: MODE button

③: +/- button

④: FAN button

⑤: SWING button

⑥: SLEEP button

⑦: TIMER button

Icon Display on Remote Controller

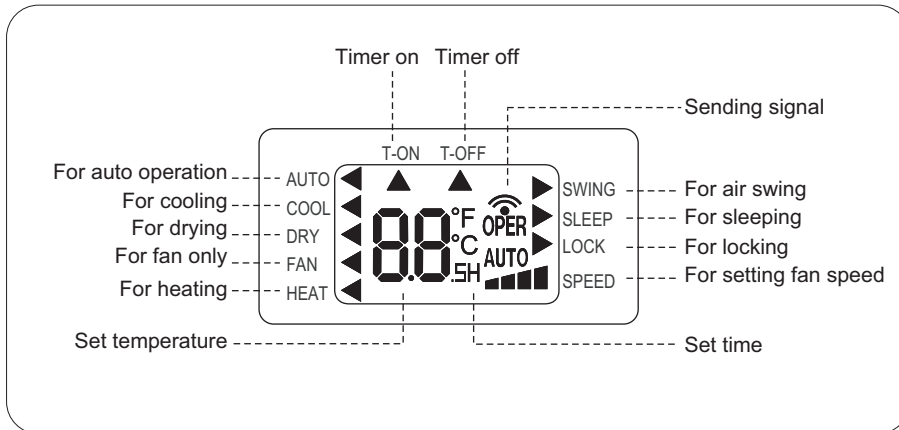

Operation introduction of remote controller

Note:

- ◆ When power is connected(stand by condition), you can operate the air conditioner through the remote controller.
- ◆ When unit is on, each time you press the button on remote controller, the sending signal icon on the display of remote controller will blink once. If the air conditioner gives out a beep sound, it means the signal has been sent.
- ◆ When unit is off, set temperature will be displayed on the remote controller(If the light of indoor unit display is turned on, the corresponding icon will be displayed); When unit is on, it will display the icon of the on-going function.

1. ON/OFF Button

Press this button to turn unit on/off.

2. MODE Button

Pressing this button once can select your required mode circularly as below(the corresponding icon will be lit up after the mode is selected):



- ◆ When selecting auto mode, air conditioner will operate automatically according to ex-factory setting. Set temperature can't be adjusted and won't be displayed either. Press FAN button to adjust fan speed. (This function is not available in this air conditioner.)
- ◆ When selecting cool mode, air conditioner will operate under cool mode. Then press + or -- button to adjust set temperature. Press FAN button to adjust fan speed.
- ◆ When selecting dry mode, air conditioner will operate at low fan speed under dry mode. In dry mode, fan speed can't be adjusted.
- ◆ When selecting fan mode, air conditioner will operate in fan mode only. Then press FAN button to adjust fan speed.
- ◆ When selecting heat mode, air conditioner will operate under heat mode. Then press + or -- button to adjust set temperature. Press FAN button to adjust fan speed.

3. +/- button

- ◆ Pressing + or - button once will increase or decrease set temperature by 1 °F(°C). Hold + or -- button for 2s, set temperature on remote controller will change quickly. Release the button after your required set temperature is reached.
- ◆ When setting Timer On, Timer Off or Clock, press + or -- button to adjust the time (See TIMER Button for setting details).

4. FAN Button

Pressing this button can select fan speed circularly as: AUTO, SPEED 1 (1 bar), SPEED 2 (2 bars), SPEED 3 (3 bars), SPEED 4 (4 bars) (unavailable in this air conditioner. Speed 4 is the same with speed 3).

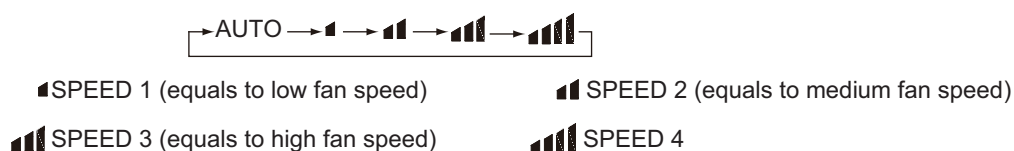

Note:

- ◆ Under Auto mode, air conditioner will select proper fan speed automatically according to ex-factory setting.
- ◆ Fan speed can't be adjusted under Dry mode.

5. SWING Button

Press this button to turn on up&down air swing.

6. SLEEP Button

Under Cool, Heat, Dry mode, press this button to turn on Sleep function. Press this button to cancel Sleep function. Under Fan and Auto mode, this function is unavailable.

7. TIMER Button

- ◆ When unit is on, press this button to set Timer Off. T-OFF and H icon will be blinking. Within 5s, press + or - button to adjust the time for Timer Off. Pressing + or - button once will increase or decrease the time by 0.5h. Hold + or - button for 2s, time will change quickly. Release the button after your required set time is reached. Then press TIMER button to confirm it. T-OFF and H icon will stop blinking.
- ◆ When unit is off, press this button to set Timer On. T-ON and H icon will be blinking. Within 5s, press + or - button to adjust the time for Timer On. Pressing + or - button once will increase or decrease the time by 0.5h. Hold + or - button for 2s, time will change quickly. Release the button after your required set time is reached. Then press TIMER button to confirm it. T-ON and H icon will stop blinking.
- ◆ Cancel Timer On/Off: If Timer function is set up, press TIMER button once to review the remaining time. Within 5s, press TIMER button again to cancel this function.

Note:

- ◆ Range of time setting is: 0.5~24h.
- ◆ The interval between two motions can't exceed 5s, otherwise the remote controller will exit setting status.

Simple operation first

1. After putting through power "ON/OFF" button on remote controller to turn on the air conditioner.
2. Press "MODE" button to select your required operation mode: AUTO, COOL, DRY, FAN.
3. Press "+" or "-" button to set your required temperature. (temperature can't adjusted under AUTO mode)
4. Press "FAN" button to select your required fan speed: auto, first notch, second notch, third notch, fourth notch (fourth notch is same as third notch for this air conditioner.)

Replacement of Batteries in Remote Controller

1. Press the back side of remote controller on the spot marked with , and then push out the cover of battery box along the arrow direction.
2. Replace two No.7 (AAA 1.5V) dry batteries and make sure the positions of + and -- polar are correct.
3. Reinstall the cover of battery box.

Note:

- ◆ During operation, point the signal sender of the remote controller at the receiving window of the indoor unit;
- ◆ The distance between signal sender and receiving window should be within 8m. There should be no obstacle between them.
- ◆ Signal may be interfered easily in the room where there is fluorescent lamp or wireless telephone; Remote controller should be close to indoor unit during operation.
- ◆ Replace new batteries of the same model when replacement is required.
- ◆ If you don't use remote controller for a long time, please take out the batteries.
- ◆ If the display on remote controller is fuzzy or if there's no display, please replace batteries.

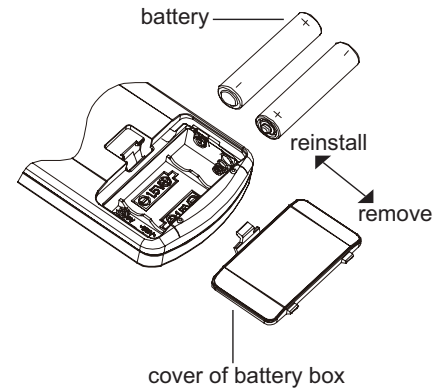

6.2 Brief Description of Modes and Functions

1. Temperature Parameters

- ◆ Indoor preset temperature (T_{preset})
- ◆ Indoor ambient temperature ($T_{\text{amb.}}$)

2. Basic Functions

Once energized, in no case should the compressor be restarted within less than 3 minutes. In the situation that memory function is available, for the first energization, if the compressor is at stop before de-energization, the compressor will be started without a 3-minute lag; if the compressor is in operation before de-energization, the compressor will be started with a 3-minute lag; and once started, the compressor will not be stopped within 6 minutes regardless of changes in room temperature;

(1) Cooling Mode

① Working conditions and process of cooling

Cooling conditions and process(09k)

- a. When $T_{\text{amb.}} \geq T_{\text{preset}}$ the unit starts cooling. In this case, the IDU fan motor, ODU fan motor and compressor run, and the IDU fan motor runs at set speed;
- b. When $T_{\text{amb.}} = T_{\text{preset}} - 3^{\circ}\text{C}$, the compressor continuously operates below the frequency of 15Hz (not including 15Hz) for 15mins. If $T_{\text{amb.}} = T_{\text{set}} - 3^{\circ}\text{C}$ still keeps the same, the compressor stops operation;
- c. When $T_{\text{amb.}} \leq T_{\text{preset}} - 4^{\circ}\text{C}$, the compressor stops operation; ODU fan motor stops operation with a delay of 30s and IDU fan motor operates at set speed;
- d. When $T_{\text{preset}} - 2^{\circ}\text{C} < T_{\text{amb.}} < T_{\text{set}}$, the unit will maintain its previous running status.

Cooling conditions and process(12k)

- a. When $T_{\text{amb.}} + T_{\text{indoor supplementary}} \geq T_{\text{preset}}$, the unit starts cooling. In this case, the IDU fan motor, ODU fan motor and compressor run, and the IDU fan motor runs at set speed;
 - b. When $T_{\text{amb.}} + T_{\text{indoor supplementary}} \leq T_{\text{preset}} - 2^{\circ}\text{C}$, the compressor stops operation; ODU fan motor stops operation with a delay of 30s and IDU fan motor operates at set speed;
 - c. When $T_{\text{preset}} - 2^{\circ}\text{C} < T_{\text{indoor amb.}} + T_{\text{indoor supplementary}} < T_{\text{preset}}$, the unit will maintain its previous running status.
- Under this mode, the four-way valve will be de-energized and temperature can be set within a range from 16 to 30°C. If the compressor is shut down for some reason, the indoor fan and the swing device will operate at original state.

② Protection

◆ Antifreeze protection

Under cooling and dehumidifying mode, 6 minutes after the compressor is started:

If $T_{\text{evap}} \leq 2^{\circ}\text{C}$, the compressor will operate at reduced frequency.

If $T_{\text{evap}} \leq -1^{\circ}\text{C}$ is detected for durative 3 minutes, the compressor will stop, and after 30 seconds, the outdoor fan will stop; and under cooling mode, the indoor fan and the swing motor will remain at the original state.

If $T_{\text{evap.}} \geq 10^{\circ}\text{C}$ and the compressor has remained at OFF for at least 3 minutes, the compressor will resume its original operation state.

◆ Total current up and frequency down protection

If $I_{\text{total}} \leq 6$, frequency rise will be allowed; if $I_{\text{total}} \geq 7$, frequency rise will not be allowed; if $I_{\text{total}} \geq 8$, the compressor will run at reduced frequency; and if $I_{\text{total}} \geq 9$, the compressor will stop and the outdoor fan will stop with a time lag of 30s.

(2) Dehumidifying Mode

① Working conditions and process of dehumidifying

If $T_{\text{amb.}} > T_{\text{preset}}$, the unit will enter cooling and dehumidifying mode, in which case the compressor and the outdoor fan will operate and the indoor fan will run at low speed.

If $T_{\text{preset}} - 2^{\circ}\text{C} \leq T_{\text{amb.}} \leq T_{\text{preset}}$, the compressor remains at its original operation state.

If $T_{\text{amb.}} < T_{\text{preset}} - 2^{\circ}\text{C}$, the compressor will stop, the outdoor fan will stop with a time lag of 30s, and the indoor fan will operate at low speed.

② Protection

Protection is the same as that under the cooling mode.

(3) Heating Mode

① Working conditions and process of heating

If $T_{amb} \leq T_{preset} + 2^{\circ}\text{C}$, the unit enters heating mode, in which case the four-way valve, the compressor and the outdoor fan will operate simultaneously, and the indoor fan will run at preset speed in the condition of preset cold air prevention.

If $T_{amb} \geq T_{preset} + 5^{\circ}\text{C}$, the compressor will stop, the outdoor fan will stop with a time lag of 30s, and the indoor fan will stop after 60-second blow at low speed

If $T_{preset} + 2^{\circ}\text{C} < T_{amb} < T_{preset} + 5^{\circ}\text{C}$, the unit will maintain its original operating status.

Under this mode, the four-way valve is energized and temperature can be set within a range of 16 - 30°C. The operating symbol, the heating symbol and preset temperature are revealed on the display.

② Condition and process of defrost

When duration of successive heating operation is more than 45 minutes, or accumulated heating time more than 90 minutes, and one of the following conditions is reached, the unit will enter the defrost mode after 3 minutes.

(1) $T_{\text{outdoor ambient}} > 5^{\circ}\text{C}$, $T_{\text{outdoor tube}} \leq -2^{\circ}\text{C}$;

(2) $-2^{\circ}\text{C} \leq T_{\text{outdoor ambient}} < 5^{\circ}\text{C}$, $T_{\text{outdoor tube}} \leq -6^{\circ}\text{C}$;

(3) $-5^{\circ}\text{C} \leq T_{\text{outdoor ambient}} < -2^{\circ}\text{C}$, $T_{\text{outdoor tube}} \leq -8^{\circ}\text{C}$;

(4) $-10^{\circ}\text{C} \leq T_{\text{outdoor ambient}} < -5^{\circ}\text{C}$, $T_{\text{outdoortube}} - T_{\text{compensatory}} \leq (T_{\text{outdoor ambient}} - 3^{\circ}\text{C})$

(5) $T_{\text{outdoor ambient}} < -10^{\circ}\text{C}$, $T_{\text{outdoortube}} - T_{\text{compensatory}} \leq (T_{\text{outdoor ambient}} - 3^{\circ}\text{C})$

(after energizing, $T_{\text{compensatory}} = 0^{\circ}\text{C}$ during the first defrosting; if it is not the first defrosting, $T_{\text{compensatory}}$ is confirmed by $T_{\text{outdoortube}}$ of quitting last defrosting:

a. when $T_{\text{outdoor tube}} > 2^{\circ}\text{C}$, $T_{\text{compensatory}} = 0^{\circ}\text{C}$; b. when $T_{\text{outdoor tube}} \leq 2^{\circ}\text{C}$, $T_{\text{compensatory}} = 3^{\circ}\text{C}$)

At that time, the indoor fan stops and the compressor stops, and after 30 seconds the outer fan will stop, and then after 30 seconds, the four-way valve will stop. After 30 seconds, the compressor is initiated for raising the frequency to defrost frequency.

When the compressor has operated under defrost mode for 7.5 minutes, or $T_{\text{outdoor ambient}} \geq 10^{\circ}\text{C}$, the compressor will be converted to 46Hz operation. After 30 seconds, the compressor will stop. And after another 30 seconds, the four-way valve will be opened, and after 60 seconds, the compressor and the outer fan will be started, the indoor fan will run under preset cold air prevention conditions, and H1 will be displayed at temperature display area on the display panel. Defrost frequency is 85Hz.

③ Protection

◆ Cold air prevention

The unit is started under heating mode (the compressor is ON):

① In the case of $T_{\text{indoor amb.}} < 24^{\circ}\text{C}$: if $T_{\text{tube}} \leq 40^{\circ}\text{C}$ and the indoor fan is at stop state, the indoor fan will begin to run at low speed with a time lag of 2 minutes. Within 2 minutes, if $T_{\text{tube}} > 40^{\circ}\text{C}$, the indoor fan also will run at low speed; and after 1-minute operation at low speed, the indoor fan will be converted to operation at preset speed. Within 1-minute low speed operation or 2-minute non-operation, if $T_{\text{tube}} > 42^{\circ}\text{C}$, the fan will run at present speed.

② In the case of $T_{\text{indoor amb.}} \geq 24^{\circ}\text{C}$: if $T_{\text{tube}} \leq 42^{\circ}\text{C}$, the indoor fan will run at low speed, and after one minute, the indoor fan will be converted to preset speed. Within one-minute low speed operation, if $T_{\text{tube}} > 42^{\circ}\text{C}$, the indoor fan will be converted to preset speed.

Note: $T_{\text{indoor amb.}}$ indicated in ① and ② refers to, under initially heating mode, the indoor ambient temperature before the command to start the compressor is performed according to the program, or after the unit is withdrawn from defrost, the indoor ambient temperature before the defrost symbol is cleared.

◆ Total current up and frequency down protection

If the total current $I_{\text{total}} \leq 6$, frequency rise will be allowed; if $I_{\text{total}} \geq 7$, frequency rise will not be allowed; if $I_{\text{total}} \geq 8$, the compressor will run at reduced frequency; and if $I_{\text{total}} \geq 9$, the compressor will stop and the outdoor fan will stop with a time lag of 30s.

(4) Fan Mode

Under the mode, the indoor fan will run at preset speed and the compressor, the outdoor fan, the four-way valve and the electric heater will stop.

Under the mode, temperature can be set within a range of 16 - 30°C .

(5) AUTO Mode

① Working conditions and process of AUTO mode

a. When $T_{\text{ambient}} \geq 26^{\circ}\text{C}$, the unit will operate in Cool mode. The set temperature is 25°C.

b. When $T_{\text{ambient}} \leq 22^{\circ}\text{C}$, the heat pump unit will operate in Heat mode., set temperature be 20°C; the cooling only unit will operate in Fan mode, set temperature be 25°C.

c. When $23^{\circ}\text{C} \leq T_{\text{ambient}} \leq 25^{\circ}\text{C}$, the unit will operate in the previous state. If it is energized for the first time, it will operate in Fan mode.

d. Under auto mode, if its cooling mode, operation frequency is same as that under cooling mode; if its heating mode, operation frequency is same as that under heating mode.

② Protection

- In cooling operation, protection is the same as that under the cooling mode;
- In heating operation, protection is the same as that under the heating mode;
- When ambient temperature changes, operation mode will be converted preferentially. Once started, the compressor will remain unchanged for at least 6 minutes.

(6) Common Protection Functions and Fault Display under COOL, HEAT, DRY and AUTO Modes

① Overload protection

T tube: measured temperature of outdoor heat exchanger under cooling mode; and measured temperature of indoor heat exchanger under heating mode.

1) Cooling overload

- If $T_{\text{tube}} \leq 52^{\circ}\text{C}$, the unit will return to its original operation state.
- If $T_{\text{tube}} \geq 55^{\circ}\text{C}$, frequency rise is not allowed.
- If $T_{\text{tube}} \geq 58^{\circ}\text{C}$, the compressor will run at reduced frequency.
- If $T_{\text{tube}} \geq 62^{\circ}\text{C}$, the compressor will stop and the indoor fan will run at preset speed.

2) Heating overload

- If $T_{\text{tube}} \leq 50^{\circ}\text{C}$, the unit will return to its original operation state.
- If $T_{\text{tube}} \geq 53^{\circ}\text{C}$, frequency rise is not allowed.
- If $T_{\text{tube}} \geq 56^{\circ}\text{C}$, the compressor will run at reduced frequency.
- If $T_{\text{tube}} \geq 60^{\circ}\text{C}$, the compressor will stop and the indoor fan will blow residue heat and then stop.

② Exhaust temperature protection of compressor

- If exhaust temperature $\geq 98^{\circ}\text{C}$, frequency is not allowed to rise.
- If exhaust temperature $\geq 103^{\circ}\text{C}$, the compressor will run at reduced frequency.
- If exhaust temperature $\geq 110^{\circ}\text{C}$, the compressor will stop.
- If exhaust temperature $\leq 90^{\circ}\text{C}$ and the compressor has stayed at stop for at least 3 minutes, the compressor will resume its operation.

③ Communication fault

If the unit fails to receive correct signals for durative 3 minutes, communication fault can be justified and the whole system will stop.

④ Module protection

Under module protection mode, the compressor will stop. When the compressor remains at stop for at least 3 minutes, the compressor will resume its operation. If module protection occurs six times in succession, the compressor will not be started again.

⑤ Overload protection

If temperature sensed by the overload sensor is over 115°C , the compressor will stop and the outdoor fan will stop with a time lag of 30 seconds. If temperature is below 95°C , the overload protection will be relieved.

⑥ DC bus voltage protection

If voltage on the DC bus is below 150V or over 420V, the compressor will stop and the outdoor fan will stop with a time lag of 30 seconds. When voltage on the DC bus returns to its normal value and the compressor has stayed at stop for at least 3 minutes, the compressor will resume its operation.

⑦ Faults of temperature sensors

Designation of sensors	Faults
Indoor ambient temperature	The sensor is detected to be open-circuited or short-circuited for successive 30 seconds
Indoor tube temperature	The sensor is detected to be open-circuited or short-circuited for successive 30 seconds
Outdoor ambient temperature	The sensor is detected to be open-circuited or short-circuited for successive 30 seconds
Outdoor tube temperature	The sensor is detected to be open-circuited or short-circuited for successive 30 seconds, and no detection is performed within 10 minutes after defrost begins.
Exhaust	After the compressor has operated for 3 minutes, the sensor is detected to be open-circuited or short-circuited for successive 30 seconds.
Overload	After the compressor has operated for 3 minutes, the sensor is detected to be open-circuited or short-circuited for successive 30 seconds.
Zero-crossing inspection circuit malfunction of the IDU fan motor	Zero-crossing signal is not detected for continuously 3s; Or the interval between the zero-crossing signals in $3\text{s} > 25\text{ms}$ (power frequency: 50Hz)

Indoor Units

(1) ON/OFF

Press the remote button ON/OFF: the on-off state will be changed once each time you press the button.

(2) Mode Selection

Press the remote button MODE, then select and show in the following ways: AUTO, COOL, DRY, FAN, HEAT, AUTO.

(3) Temperature Setting Option Button

Each time you press the remote button TEMP+ or TEMP-, the setting temperature will be up or down by 1°C. Regulating Range: 16~30°C, the button is useless under the AUTO mode.

(4) Time Switch

You should start and stop the machine according to the setting time by remote control.

(5) SLEEP State Control

a. When the air conditioner is under the mode of COOL, DRY, and the SLEEP mode has been set well, after the SLEEP state keeps about 1 hour, the pre-setting T will raise 1°C, and it will raise 1°C again after 2 hours, so it raise 2°C in 2 hours, then it will run on at the setting temperature and wind speed.

b. When the air conditioner is under the mode of HEAT, and the Timer has been set well, after the SLEEP state keeps about 1 hour, the pre-setting T will reduce 1°C, and it will reduce 1°C again after 2 hours, so it reduce 2°C in 2 hours, then it will run on at the setting temperature and wind speed.

c. The setting temperature keeps the same under the FAN mode and AUTO mode.

(6) Buzzer Control

a. Cooling only model: The buzzer will send a "Di Di" sound when the air conditioner is powered up or received the information sent by the remote control or there is a button input, the single tube cooler doesn't receive the remote control ON signal under the mode of heating mode.

b. Cooling and heating model: The buzzer will send a "Di" sound when the air conditioner is powered up or received the information sent by the remote control or there is a button input, the single tube cooler doesn't receive the remote control ON signal under the mode of heating mode.

(7) Auto button

If the controller is on, it will stop by pressing the button, and if the controller is off, it will be automatic running state by pressing the button, swing on and light on, and the main unit will run based on the remote control if there is remote control order.

(8) Up-and-Down Swinging Control

When power on, the up-and-down motor will firstly move the air deflector to counter-clockwise, close the air outlet. After starting the machine, if you don't set the swinging function, heating mode and auto-heating mode, the up-and-down air deflector will move to D clockwise; under other modes, the up-and-down air deflector will move to L1. If you set the swinging function when you start the machine, then the wind blade will swing between L and D. The air deflector has 7 swinging states: Location L, Location A, Location B, Location C, Location D, Location L to Location D, stop at any location between L-D (the included angle between L~D is the same). The air deflector will be closed at 0 Location, and the swinging is effectual only on condition that setting the swinging order and the inner fan is running. The indoor fan and compressor may get the power when air deflector is on the default location.

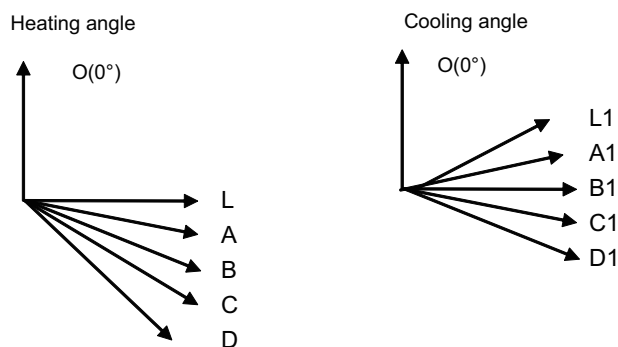

(9) Display

① Operation pattern and mode pattern display

All the display patterns will display for a time when the power on, the operation indication pattern will display in red under standby status. When the machine is start by remote control, the indication pattern will light and display the current operation mode (the mode light includes:

Cooling, heating and dehumidify). If you close the light key, all the display patterns will close.

② Double-8 display

According to the different setting of remote control, the nixie light may display the current temperature (the temperature scope is from 16°C to 30°C) and indoor ambient temperature. The set temperature displayed in auto cooling and fan mode is 25°C, The set temperature displayed in auto heating mode is 20°C and the temperature will display H1 under the defrosting mode. (If you set the fahrenheit temperature display, the nixie light will display according to fahrenheit temperature)

(10) Protection function and failure display

E2: Freeze-proofing protection E4: Exhausting protection E5: Overcurrent protection

E6: Communication failure H4: Overload protection

F1: Indoor ambient sensor start and short circuit (continuously measured failure in 30S)

F2: Indoor evaporator sensor start and short circuit (continuously measured failure in 30S)

F3: Outdoor ambient sensor start and short circuit (continuously measured failure in 30S)

F4: Outdoor condenser sensor start and short circuit (continuously measured failure in 30S, and dont measure within 10 minutes after defrosted)

F5: Outdoor exhausting sensor start and short circuit (continuously measured failure in 30S after the compressor operated 3 minutes)

H3: Overload protection of compressor H5: Module protection

PH: High-voltage protection PL: Low-voltage protection

P1: Nominal cooling and heating P2: Maximum cooling and heating

P3: Medium cooling and heating P0: Minimum cooling and heating

(11) Drying Function

You may start or stop the drying function under the modes of cooling and dehumidify at the starting status (The modes of automatism, heating and air supply do not have drying function). When you start the drying function, after stop the machine by pressing the switch button, you should keep running the inner fans for 10 minutes under low air damper (The swing will operate as the former status within 10 minutes, and other load is stopped), then stop the entire machine; When you stop the drying function, press the switch button will stop the machine directly. When you start the drying function, operating the drying button will stop the inner fans and close the guide louver.

(12) Memory function when interrupting the power supply

Memory content: mode, swing function, light, set temperature and wind speed. After interrupted the power supply, the machine will start when recovering the power according to the memory content automatically. If the last remote control command has not set the timed function, the system will remember the last remote control command and operate according it. If the last remote control command has set timed function and the power supply is interrupted before the timed time, the system will remember the timed function of the last remote control command, the timed time will recounted form power on. If the last remote control command has set timed function, the time is out and the system is start or stop according to the set time when the power supply is interrupted, the system will remember the operation status before the power supply was interrupted, and do not carry out timed action; The timed clock will not remembered.

(13) Sleep function

In this mode, the system will select proper sleep curve to operate according to different set temperature.

① If start up sleep function under cooling or drying mode, the system will increase set temperature automatically within a certain range to operate.

② If start up sleep function under heating mode, the system will decrease set temperature automatically within a certain range to operate.

Part II : Installation and Maintenance

7. Notes for Installation and Maintenance

Safety Precautions: Important!

Please read the safety precautions carefully before installation and maintenance.

The following contents are very important for installation and maintenance.

Please follow the instructions below.

- The installation or maintenance must accord with the instructions.
- Comply with all national electrical codes and local electrical codes.
- Pay attention to the warnings and cautions in this manual.
- All installation and maintenance shall be performed by distributor or qualified person.
- All electric work must be performed by a licensed technician according to local regulations and the instructions given in this manual.
- Be caution during installation and maintenance. Prohibit incorrect operation to prevent electric shock, casualty and other accidents.



Warnings

Electrical Safety Precautions:

1. Cut off the power supply of air conditioner before checking and maintenance.
2. The air condition must apply specialized circuit and prohibit share the same circuit with other appliances.
3. The air conditioner should be installed in suitable location and ensure the power plug is touchable.
4. Make sure each wiring terminal is connected firmly during installation and maintenance.
5. Have the unit adequately grounded. The grounding wire can't be used for other purposes.
6. Must apply protective accessories such as protective boards, cable-cross loop and wire clip.
7. The live wire, neutral wire and grounding wire of power supply must be corresponding to the live wire, neutral wire and grounding wire of the air conditioner.
8. The power cord and power connection wires can't be pressed by hard objects.
9. If power cord or connection wire is broken, it must be replaced by a qualified person.

10. If the power cord or connection wire is not long enough, please get the specialized power cord or connection wire from the manufacture or distributor. Prohibit prolong the wire by yourself.

11. For the air conditioner without plug, an air switch must be installed in the circuit. The air switch should be all-pole parting and the contact parting distance should be more than 3mm.

12. Make sure all wires and pipes are connected properly and the valves are opened before energizing.

13. Check if there is electric leakage on the unit body. If yes, please eliminate the electric leakage.

14. Replace the fuse with a new one of the same specification if it is burnt down; don't replace it with a cooper wire or conducting wire.

15. If the unit is to be installed in a humid place, the circuit breaker must be installed.

Installation Safety Precautions:

1. Select the installation location according to the requirement of this manual.(See the requirements in installation part)
2. Handle unit transportation with care; the unit should not be carried by only one person if it is more than 20kg.
3. When installing the indoor unit and outdoor unit, a sufficient fixing bolt must be installed; make sure the installation support is firm.
4. Wear safety belt if the height of working is above 2m.
5. Use equipped components or appointed components during installation.
6. Make sure no foreign objects are left in the unit after finishing installation.

Refrigerant Safety Precautions:

1. Avoid contact between refrigerant and fire as it generates poisonous gas; Prohibit prolong the connection pipe by welding.
2. Apply specified refrigerant only. Never have it mixed with any other refrigerant. Never have air remain in the refrigerant line as it may lead to rupture or other hazards.
3. Make sure no refrigerant gas is leaking out when installation is completed.
4. If there is refrigerant leakage, please take sufficient measure to minimize the density of refrigerant.
5. Never touch the refrigerant piping or compressor without wearing glove to avoid scald or frostbite.

Improper installation may lead to fire hazard, explosion, electric shock or injury.

Main Tools for Installation and Maintenance

<p>1. Level meter, measuring tape</p> 	<p>2. Screw driver</p> 	<p>3. Impact drill, drill head, electric drill</p> 
<p>4. Electroprobe</p> 	<p>5. Universal meter</p> 	<p>6. Torque wrench, open-end wrench, inner hexagon spanner</p> 
<p>7. Electronic leakage detector</p> 	<p>8. Vacuum pump</p> 	<p>9. Pressure meter</p> 
<p>10. Pipe pliers, pipe cutter</p> 	<p>11. Pipe expander, pipe bender</p> 	<p>12. Soldering appliance, refrigerant container</p> 

8. Installation

8.1 Installation Dimension Diagram

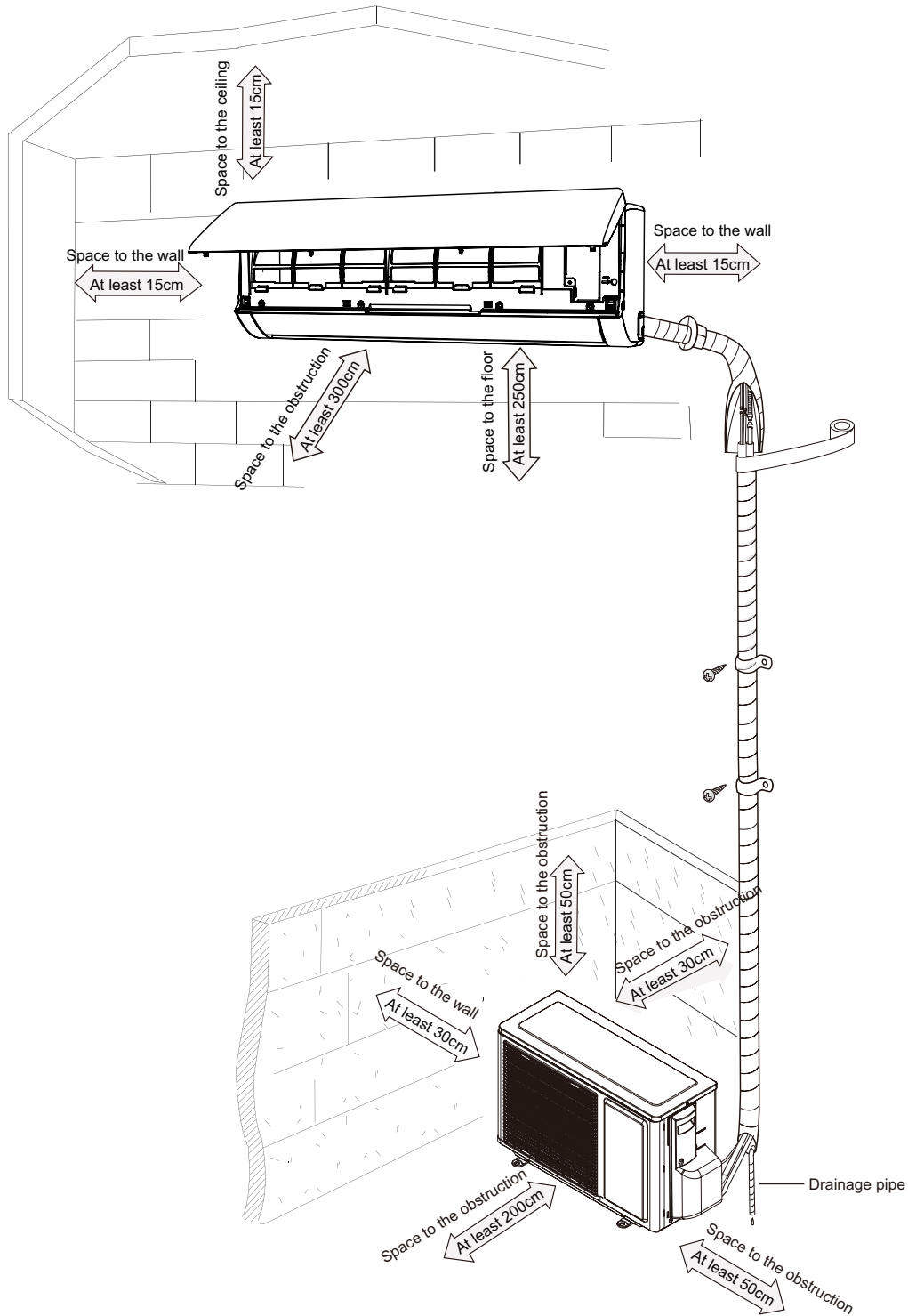

Installation procedures

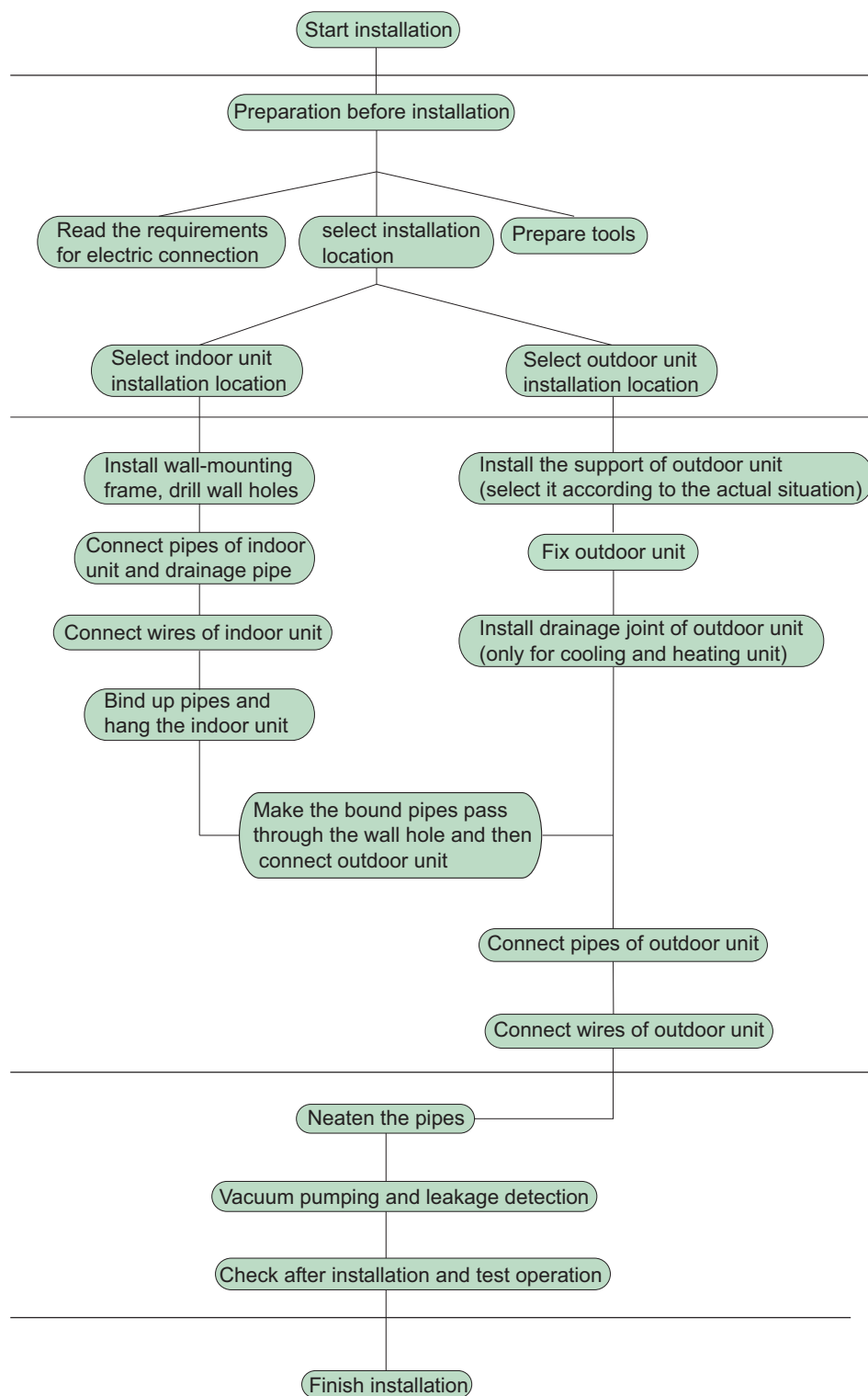

Note: this flow is only for reference; please find the more detailed installation steps in this section.

8.2 Installation Parts-checking

No.	Name	No.	Name
1	Indoor unit	8	Sealing gum
2	Outdoor unit	9	Wrapping tape
3	Connection pipe	10	Support of outdoor unit
4	Drainage pipe	11	Fixing screw
5	Wall-mounting frame	12	Drainage plug(cooling and heating unit)
6	Connecting cable(power cord)	13	Owner's manual, remote controller
7	Wall pipe		

⚠ Note:

- 1.Please contact the local agent for installation.
- 2.Don't use unqualified power cord.

8.3 Selection of Installation Location

1. Basic Requirement:

Installing the unit in the following places may cause malfunction. If it is unavoidable, please consult the local dealer:

- (1) The place with strong heat sources, vapors, flammable or explosive gas, or volatile objects spread in the air.
- (2) The place with high-frequency devices (such as welding machine, medical equipment).
- (3) The place near coast area.
- (4) The place with oil or fumes in the air.
- (5) The place with sulfured gas.
- (6) Other places with special circumstances.

2. Indoor Unit:

- (1) There should be no obstruction near air inlet and air outlet.
- (2) Select a location where the condensation water can be dispersed easily and won't affect other people.
- (3) Select a location which is convenient to connect the outdoor unit and near the power socket.
- (4) Select a location which is out of reach for children.
- (5) The location should be able to withstand the weight of indoor unit and won't increase noise and vibration.
- (6) The appliance must be installed 2.5m above floor.
- (7) Don't install the indoor unit right above the electric appliance.
- (8) The appliance shall not be installed in the laundry.

3. Outdoor Unit:

- (1) Select a location where the noise and outflow air emitted by the outdoor unit will not affect neighborhood.
- (2) The location should be well ventilated and dry, in which the outdoor unit won't be exposed directly to sunlight or strong wind.
- (3) The location should be able to withstand the weight of outdoor unit.
- (4) Make sure that the installation follows the requirement of installation dimension diagram.
- (5) Select a location which is out of reach for children and far away from animals or plants.If it is unavoidable, please add fence for safety purpose.

8.4 Electric Connection Requirement

1. Safety Precaution

- (1) Must follow the electric safety regulations when installing the unit.
- (2) According to the local safety regulations, use qualified power supply circuit and air switch.
- (3) Make sure the power supply matches with the requirement of air conditioner. Unstable power supply or incorrect wiring may result in electric shock,fire hazard or malfunction. Please install proper power supply cables before using the air conditioner.

Air-conditioner	Air switch capacity
07K	10A

- (4) Properly connect the live wire, neutral wire and grounding wire of power socket.
- (5) Be sure to cut off the power supply before proceeding any work related to electricity and safety.
- (6) Do not put through the power before finishing installation.
- (7) For appliances with type Y attachment,the instructions shall contain the substance of thefollowing.If the supply cord is damaged,it must be replaced by the manufacturer,its service agent or similarly qualified persons in order to avoid a hazard.
- (8) The temperature of refrigerant circuit will be high, please keep the interconnection cable away from the copper tube.

2. Grounding Requirement:

- (1) The air conditioner is first class electric appliance. It must be properly grounding with specialized grounding device by a professional. Please make sure it is always grounded effectively, otherwise it may cause electric shock.
- (2) The yellow-green wire in air conditioner is grounding wire, which can't be used for other purposes.
- (3) The grounding resistance should comply with national electric safety regulations.
- (4) The appliance must be positioned so that the plug is accessible.
- (5) An all-pole disconnection switch having a contact separation of at least 3mm in all poles should be connected in fixed wiring.
- (6) Including an air switch with suitable capacity, please note the following table. Air switch should be included magnet buckle and heating buckle function, it can protect the circuit-short and overload. (Caution: please do not use the fuse only for protect the circuit)

8.5 Installation of Indoor Unit

1. Choosing Installation location

Recommend the installation location to the client and then confirm it with the client.

2. Install Wall-mounting Frame

- (1) Hang the wall-mounting frame on the wall; adjust it in horizontal position with the level meter and then point out the screw fixing holes on the wall.
- (2) Drill the screw fixing holes on the wall with impact drill (the specification of drill head should be the same as the plastic expansion particle) and then fill the plastic expansion particles

in the holes.

(3) Fix the wall-mounting frame on the wall with tapping screws (ST4.2X25TA) and then check if the frame is firmly installed by pulling the frame. If the plastic expansion particle is loose, please drill another fixing hole nearby.

3. Install Wall-mounting Frame

(1) Choose the position of piping hole according to the direction of outlet pipe. The position of piping hole should be a little lower than the wall-mounted frame. (As show in Fig.1)

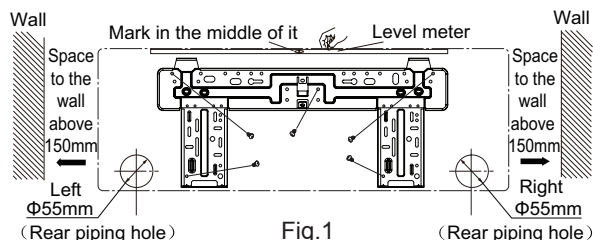

(2) Open a piping hole with the diameter of Φ55mm on the selected outlet pipe position. In order to drain smoothly, slant the piping hole on the wall slightly downward to the outdoor side with the gradient of 5-10°. (As show in Fig.2)

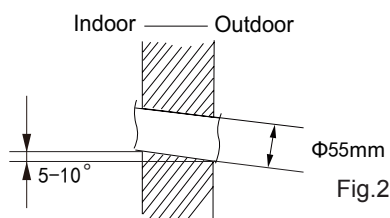

⚠ Note:

- (1) Pay attention to dust prevention and take relevant safety measures when opening the hole.
- (2) The plastic expansion particles are not provided and should be bought locally.

4. Outlet Pipe

- (1) The pipe can be led out in the direction of right, rear right, left or rear left. (As show in Fig.3)
- (2) When selecting leading out the pipe from left or right, please cut off the corresponding hole on the bottom case. (As show in Fig.4)

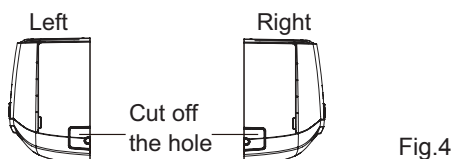
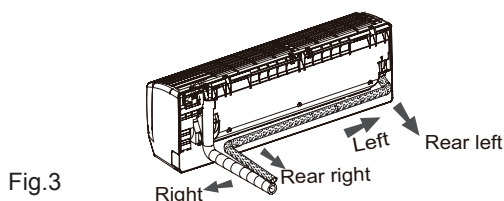

5. Connect the Pipe of Indoor Unit

- (1) Aim the pipe joint at the corresponding bellmouth. (As show in Fig.5)
- (2) Pretightening the union nut with hand.
- (3) Adjust the torque force by referring to the following sheet. Place the open-end wrench on the pipe joint and place the torque wrench on the union nut. Tighten the union nut with torque wrench. (As show in Fig.6)
- (4) Wrap the indoor pipe and joint of connection pipe with insulating pipe, and then wrap it with tape. (As show in Fig.7)

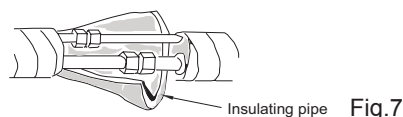
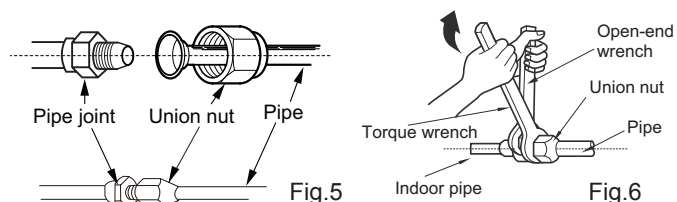

Refer to the following table for wrench moment of force:

Hex nut diameter(mm)	Tightening torque(N·m)
Φ6	15~20
Φ9.52	30~40
Φ12	45~55
Φ16	60~65
Φ19	70~75

6. Install Drain Hose

- (1) Connect the drain hose to the outlet pipe of indoor unit. (As show in Fig.8)
- (2) Bind the joint with tape. (As show in Fig.9)

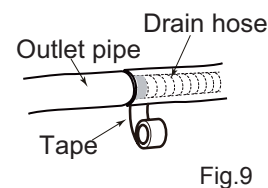
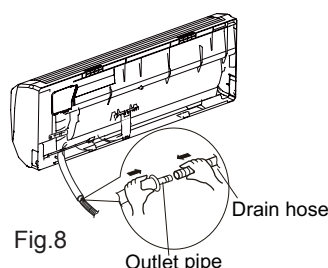

⚠ Note:

- (1) Add insulating pipe in the indoor drain hose in order to prevent condensation.
- (2) The plastic expansion particles are not provided. (As show in Fig.10)

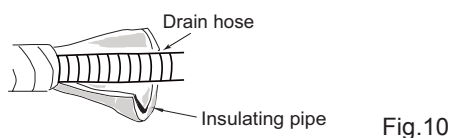

7. Connect Wire of Indoor Unit

(1) Open the panel, remove the screw on the wiring cover and then take down the cover.(As show in Fig.11)

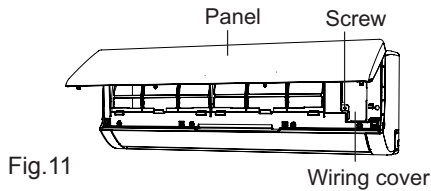

(2) Make the power connection wire go through the cable-cross hole at the back of indoor unit and then pull it out from the front side.(As show in Fig.12)

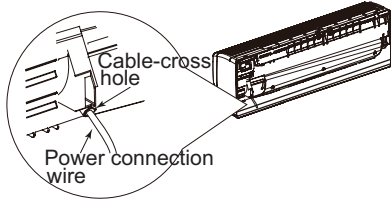

Note: This step only applicable for N.American models.

Fig.12

(3) Remove the wire clip; connect the power connection wire to the wiring terminal according to the color; tighten the screw and then fix the power connection wire with wire clip.(As show in Fig.13)

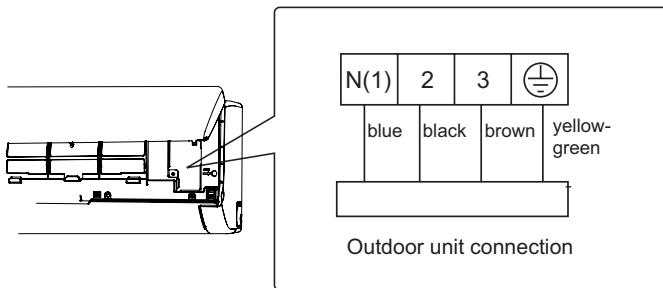

Note: the wiring connect is for reference only, please refer to the actual one.

Fig.13

(4) Put wiring cover back and then tighten the screw.
 (5) Close the panel.

⚠ Note:

- (1) All wires of indoor unit and outdoor unit should be connected by a professional.
- (2) If the length of power connection wire is insufficient, please contact the supplier for a new one. Avoid extending the wire by yourself.
- (3) For the air conditioner with plug, the plug should be reachable after finishing installation.
- (4) For the air conditioner without plug, an air switch must be installed in the line. The air switch should be all-pole parting and the contact parting distance should be more than 3mm.

8. Bind up Pipe

- (1) Bind up the connection pipe, power cord and drain hose with the band.(As show in Fig.14)
- (2) Reserve a certain length of drain hose and power cord for installation when binding to a certain degree, separate the indoor power and then separate the drain hose.(As show in Fig.15)
- (3) Bind them evenly.
- (4) The liquid pipe and gas pipe should be bound separately at the end.

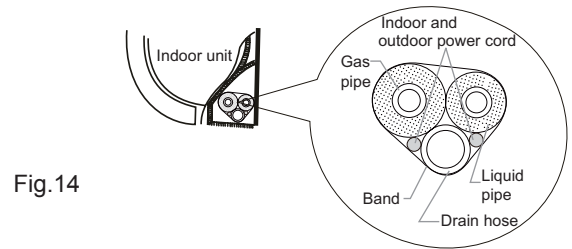

Fig.14

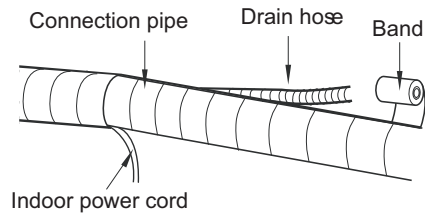

Fig.15

⚠ Note:

- (1) The power cord and control wire can't be crossed or winding.
- (2) The drain hose should be bound at the bottom.

9. Hang the Indoor Unit

- (1) Put the bound pipes in the wall pipe and then make them pass through the wall hole.
- (2) Hang the indoor unit on the wall-mounting frame.
- (3) Stuff the gap between pipes and wall hole with sealing gum.
- (4) Fix the wall pipe.(As show in Fig.16)
- (5) Check if the indoor unit is installed firmly and closed to the wall.(As show in Fig.17)

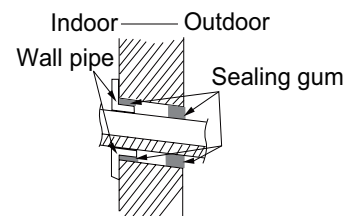

Fig.16

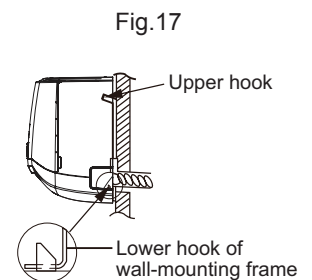

Fig.17

⚠ Note:

Do not bend the drain hose too excessively in order to prevent blocking.

8.6 Installation of Outdoor Unit

1. Fix the Support of Outdoor Unit(Select it According to the Actual Installation Situation)

- (1) Select installation location according to the house structure.
- (2) Fix the support of outdoor unit on the selected location with expansion screws.

⚠ Note:

- (1) Take sufficient protective measures when installing the outdoor unit.
- (2) Make sure the support can withstand at least four times the unit weight.
- (3) The outdoor unit should be installed at least 3cm above the floor in order to install drain joint.(As show in Fig.18)
- (4) For the unit with cooling capacity of 2300W~5000W, 6 expansion screws are needed; for the unit with cooling capacity of 6000W~8000W, 8 expansion screws are needed; for the unit with cooling capacity of 10000W~16000W, 10 expansion screws are needed.

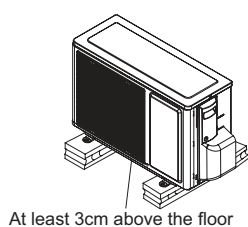

Fig.18

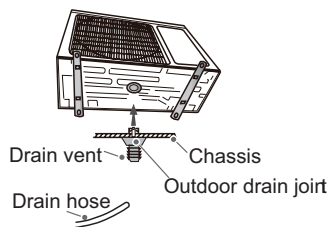

Fig.19

2. Install Drain Joint(Only for cooling and heating unit)

- (1) Connect the outdoor drain joint into the hole on the chassis.
- (2) Connect the drain hose into the drain vent.(As show in Fig.19)

3. Fix Outdoor Unit

- (1) Place the outdoor unit on the support.
- (2) Fix the foot holes of outdoor unit with bolts.(As show in Fig.20)

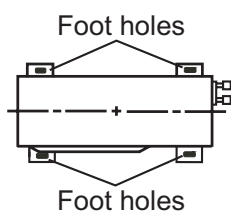

Fig.20

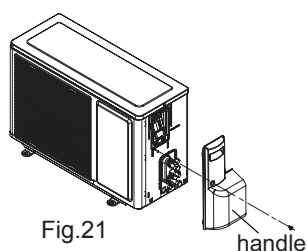

Fig.21

4. Connect Indoor and Outdoor Pipes

- (1) Remove the screw on the right handle of outdoor unit and then remove the handle.(As show in Fig.21)
- (2) Remove the screw cap of valve and aim the pipe joint at the bellmouth of pipe.(As show in Fig.22)

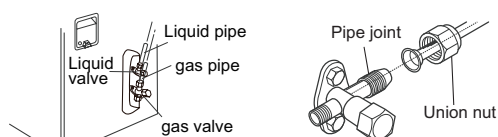

Fig.22

- (3) Pretightening the union nut with hand.
- (4) Tighten the union nut with torque wrench.

Refer to the following table for wrench moment of force:

Hex nut diameter(mm)	Tightening torque(N·m)
Φ6	15~20
Φ9.52	30~40
Φ12	45~55
Φ16	60~65
Φ19	70~75

5. Connect Outdoor Electric Wire

- (1) Remove the wire clip; connect the power connection wire to the wiring terminal according to the color; fix the power connection wire with screws.(As show in Fig.23)

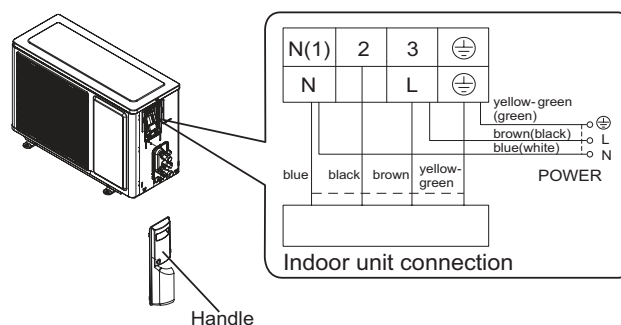

Note: the wiring connect is for reference only, please refer to the actual one.

Fig.23

- (2) Fix the power connection wire with wire clip.

⚠ Note:

- (1) After tightening the screw, pull the power cord slightly to check if it is firm.
- (2) Never cut the power connection wire to prolong or shorten the distance.

6. Neaten the Pipes

- (1) The pipes should be placed along the wall, bent reasonably and hidden possibly. Min. semidiameter of bending the pipe is 10cm.
- (2) If the outdoor unit is higher than the wall hole, you must set a U-shaped curve in the pipe before pipe goes into the room, in order to prevent rain from getting into the room.(As show in Fig.24)

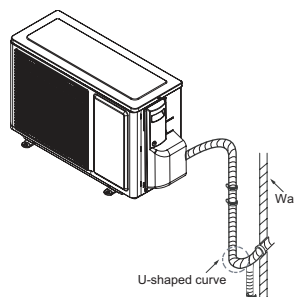

Fig.24

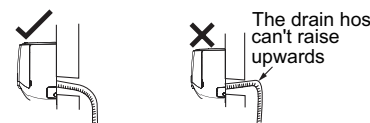
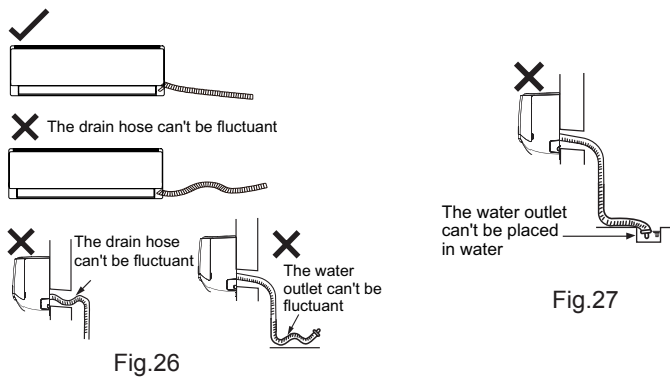

Fig.25

⚠ Note:

- (1) The through-wall height of drain hose shouldn't be higher than the outlet pipe hole of indoor unit.(As show in Fig.25)
- (2) Slant the drain hose slightly downwards. The drain hose can't be curved, raised and fluctuant, etc.(As show in Fig.26)

(3) The water outlet can't be placed in water in order to drain smoothly.(As show in Fig.27)



8.7 Vacuum Pumping and Leak Detection

1. Use Vacuum Pump

- (1) Remove the valve caps on the liquid valve and gas valve and the nut of refrigerant charging vent.
- (2) Connect the charging hose of piezometer to the refrigerant charging vent of gas valve and then connect the other charging hose to the vacuum pump.
- (3) Open the piezometer completely and operate for 10-15min to check if the pressure of piezometer remains in -0.1MPa.
- (4) Close the vacuum pump and maintain this status for 1-2min to check if the pressure of piezometer remains in -0.1MPa. If the pressure decreases, there may be leakage.
- (5) Remove the piezometer, open the valve core of liquid valve and gas valve completely with inner hexagon spanner.
- (6) Tighten the screw caps of valves and refrigerant charging vent.(As show in Fig.28)

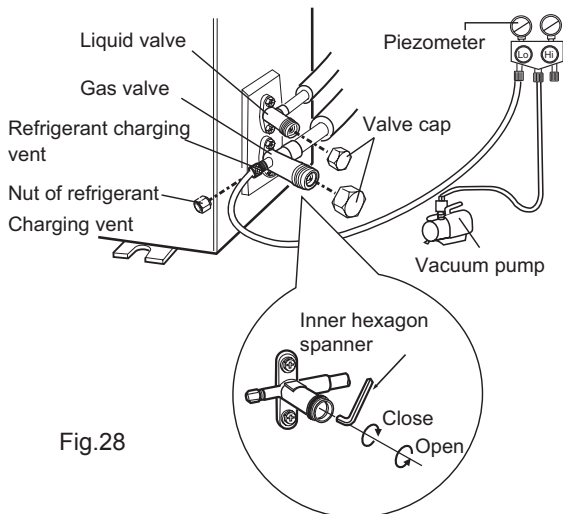

2. Leakage Detection

- (1) With leakage detector:
Check if there is leakage with leakage detector.
- (2) With soap water:
If leakage detector is not available, please use soap water for leakage detection. Apply soap water at the suspected position and keep the soap water for more than 3min. If there are air bubbles coming out of this position, there's a leakage.

8.8 Check after Installation and Test Operation

1. Check after Installation

Check according to the following requirement after finishing installation.

No.	Items to be checked	Possible malfunction
1	Has the unit been installed firmly?	The unit may drop, shake or emit noise.
2	Have you done the refrigerant leakage test?	It may cause insufficient cooling (heating) capacity.
3	Is heat insulation of pipeline sufficient?	It may cause condensation and water dripping.
4	Is water drained well?	It may cause condensation and water dripping.
5	Is the voltage of power supply according to the voltage marked on the nameplate?	It may cause malfunction or damage the parts.
6	Is electric wiring and pipeline installed correctly?	It may cause malfunction or damage the parts.
7	Is the unit grounded securely?	It may cause electric leakage.
8	Does the power cord follow the specification?	It may cause malfunction or damage the parts.
9	Is there any obstruction in air inlet and air outlet?	It may cause insufficient cooling (heating).
10	The dust and sundries caused during installation are removed?	It may cause malfunction or damaging the parts.
11	The gas valve and liquid valve of connection pipe are open completely?	It may cause insufficient cooling (heating) capacity.

2. Test Operation

- (1) Preparation of test operation
 - The client approves the air conditioner installation.
 - Specify the important notes for air conditioner to the client.
- (2) Method of test operation
 - Put through the power, press ON/OFF button on the remote controller to start operation.
 - Press MODE button to select AUTO, COOL, DRY, FAN and HEAT to check whether the operation is normal or not.
 - If the ambient temperature is lower than 16°C , the air conditioner can't start cooling.

9. Maintenance

9.1 Malfunction Analysis

Note: When replacing the controller, be sure to insert the wire jumper into the new controller, otherwise the unit will display C5

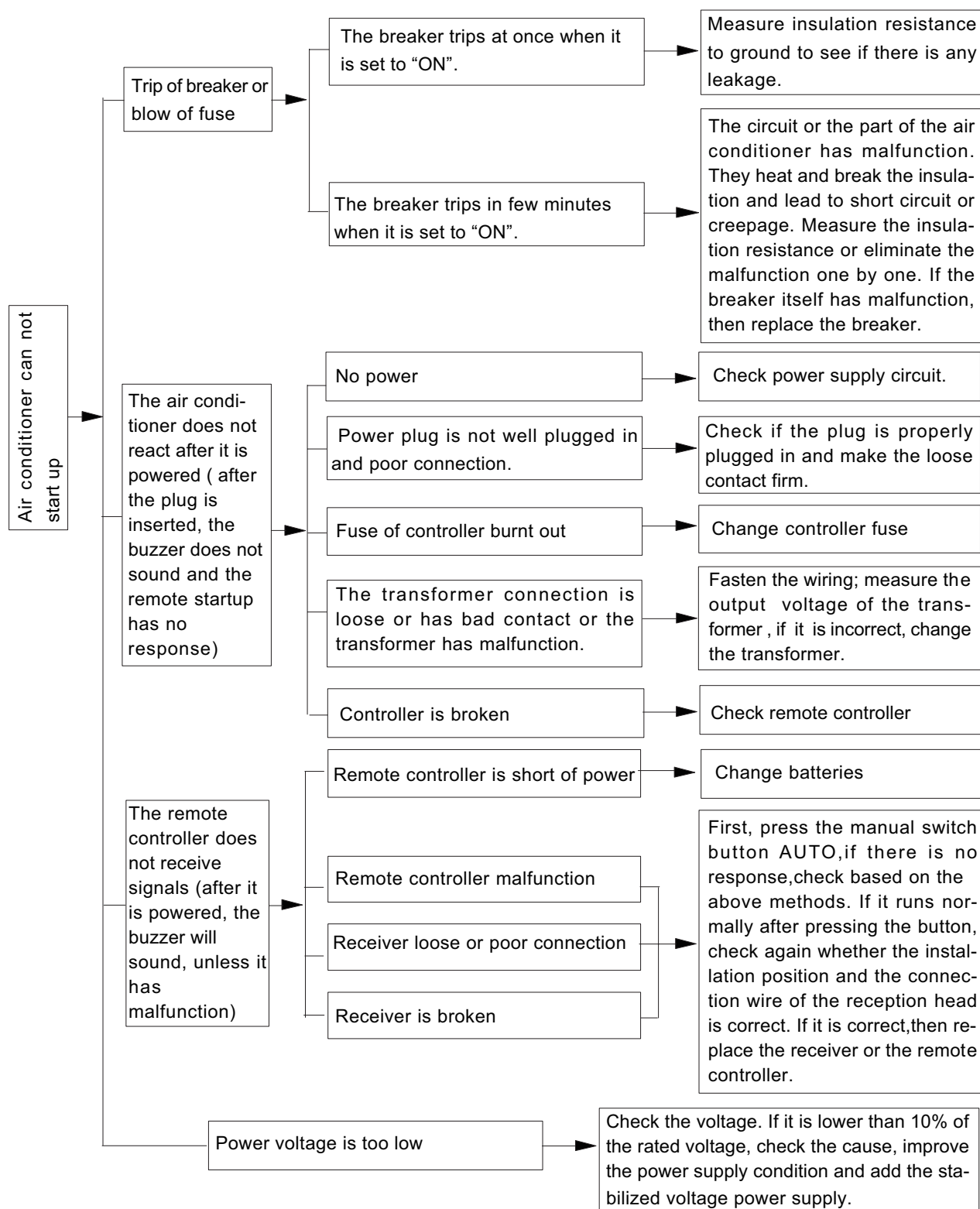

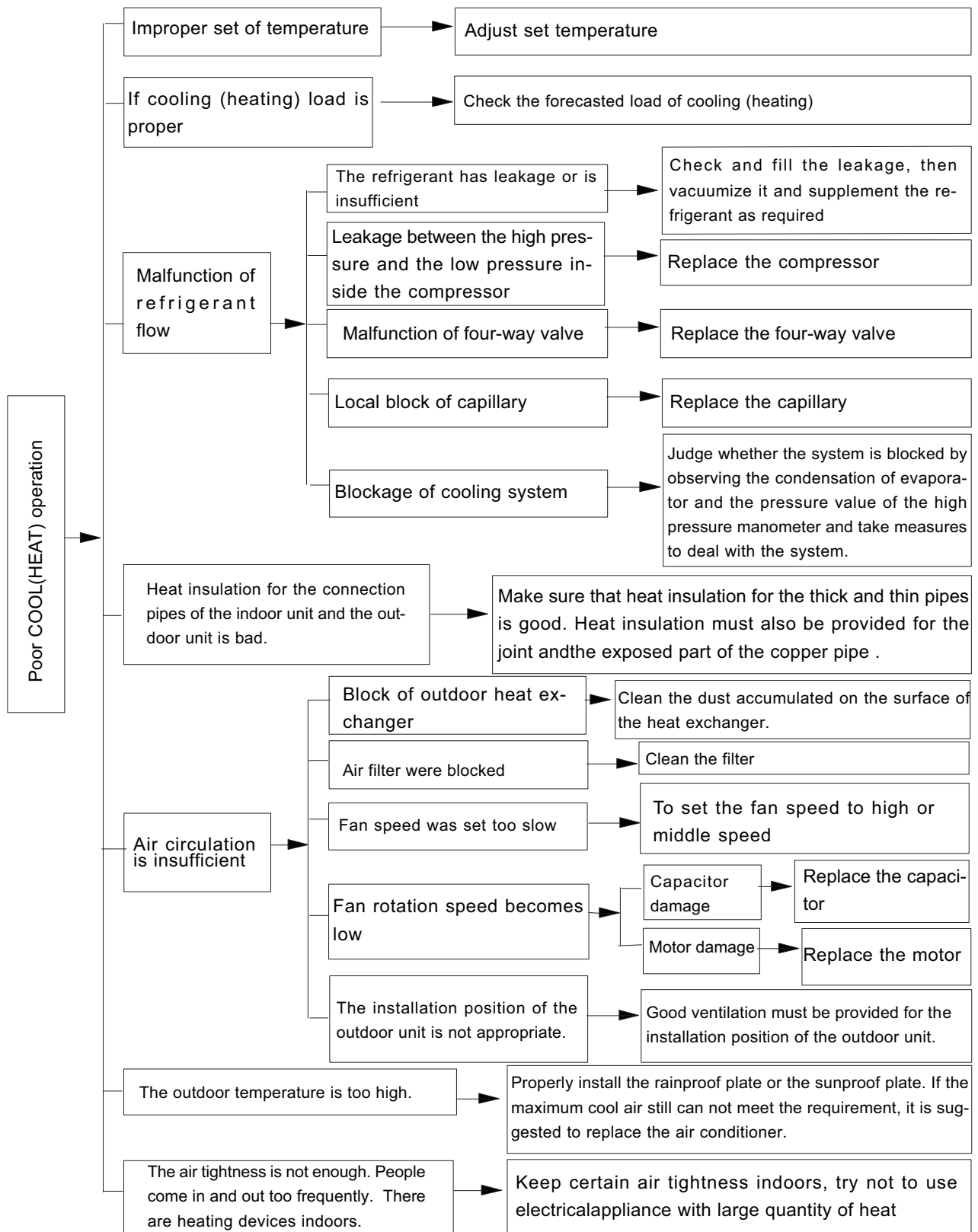

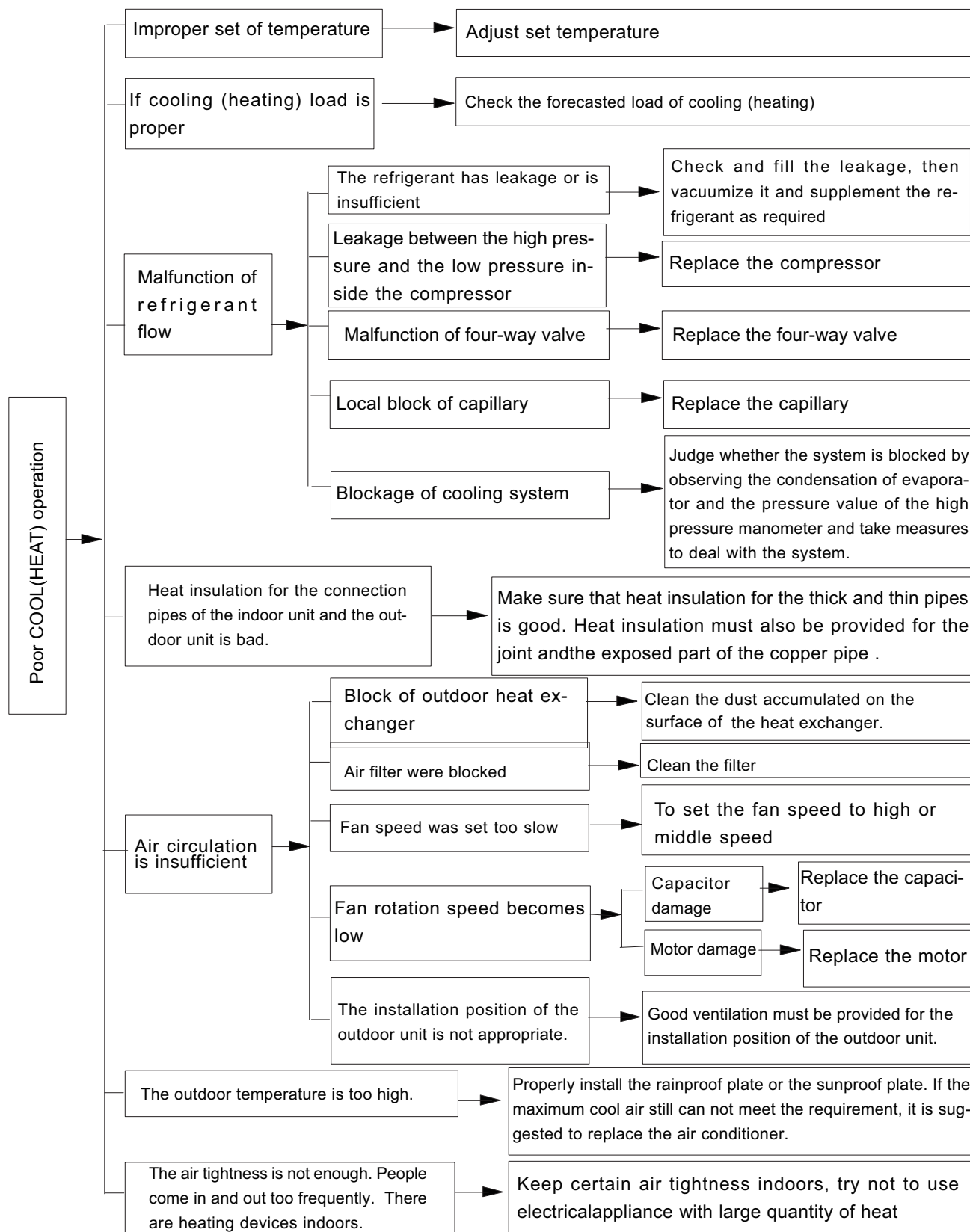

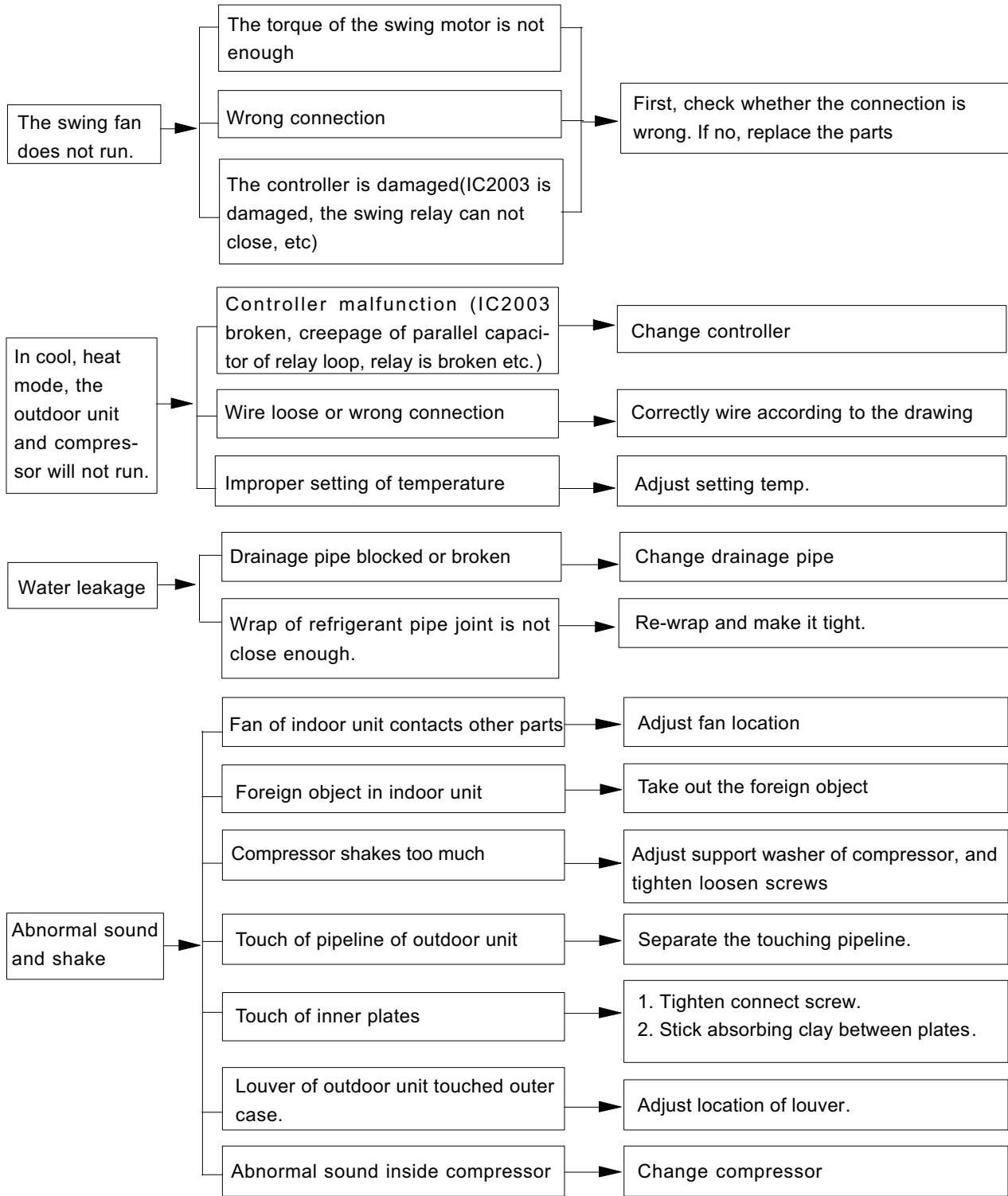

9.2 Flashing LED of Indoor/Outdoor Unit and Primary Judgement

NO.	Malfunction Name	Display Method of Indoor Unit			Display Method of Outdoor Unit			A/C status	Possible Causes	
		Dual-8 Code Display	Indicator Display (during blinking, ON 0.5s and OFF 0.5s)			Indicator has 3 kinds of display status and during blinking, ON 0.5s and OFF 0.5s				
			Operation Indicator	Cool Indicator	Heating Indicator	Yellow Indicator	Red Indicator			Green Indicator
1	High pressure protection of system	E1	OFF 3s and blink once						During cooling and drying operation, except indoor fan operates, all loads stop operation. During heating operation, the complete unit stops.	Possible reasons: 1. Refrigerant was superabundant; 2. Poor heat exchange (including filth blockage of heat exchanger and bad radiating environment); Ambient temperature is too high.
2	Antifreezing protection	E2	OFF 3S and blink twice				OFF 3S and blink 3 times		During cooling and drying operation, compressor and outdoor fan stop while indoor fan operates.	1. Poor air-return in indoor unit; 2. Fan speed is abnormal; 3. Evaporator is dirty.
3	System block or refrigerant leakage	E3	OFF 3S and blink 3 times					OFF 3S and blink 9 times	The Dual-8 Code Display will show E3 until the low pressure switch stop operation.	1.Low-pressure protection 2.Low-pressure protection of system 3.Low-pressure protection of compressor
4	High discharge temperature protection of compressor	E4	OFF 3S and blink 4 times						During cooling and drying operation, compressor and outdoor fan stop while indoor fan operates. During heating operation, all loads stop.	Please refer to the malfunction analysis (discharge protection, overload).
5	Overcurrent protection	E5	OFF 3S and blink 5 times						During cooling and drying operation, compressor and outdoor fan stop while indoor fan operates. During heating operation, all loads stop.	1. Supply voltage is unstable; 2. Supply voltage is too low and load is too high; 3. Evaporator is dirty.
6	Communication Malfunction	E6	OFF 3S and blink 6 times						During cooling operation, compressor stops while indoor fan motor operates. During heating operation, the complete unit stops.	Refer to the corresponding malfunction analysis.
7	High temperature resistant protection	E8	OFF 3S and blink 8 times						During cooling operation: compressor will stop while indoor fan will operate. During heating operation, the complete unit stops.	Refer to the malfunction analysis (overload, high temperature resistant).
8	EEPROM malfunction	EE				OFF 3S and blink 15 times	OFF 3S and blink 11 times		During cooling and drying operation, compressor will stop while indoor fan will operate; During heating operation, the complete unit will stop	Replace outdoor control panel AP1
9	Limit/ decrease frequency due to high temperature of module	EU				OFF 3S and blink 6 times	OFF 3S and blink 6 times		All loads operate normally, while operation frequency for compressor is decreased	Discharging after the complete unit is de-energized for 20mins, check whether the thermal grease on IPM Module of outdoor control panel AP1 is sufficient and whether the radiator is inserted tightly. If its no use, please replace control panel AP1.
10	Malfunction protection of jumper cap	C5	OFF 3S and blink 15 times						Wireless remote receiver and button are effective, but can not dispose the related command	1. No jumper cap insert on mainboard. 2. Incorrect insert of jumper cap. 3. Jumper cap damaged. 4. Abnormal detecting circuit of mainboard.

NO.	Malfunction Name	Display Method of Indoor Unit			Display Method of Outdoor Unit			A/C status	Possible Causes	
		Dual-8 Code Display	Indicator Display (during blinking, ON 0.5s and OFF 0.5s)			Indicator has 3 kinds of display status and during blinking, ON 0.5s and OFF 0.5s				
			Operation Indicator	Cool Indicator	Heating Indicator	Yellow Indicator	Red Indicator			Green Indicator
11	Gathering refrigerant	Fo	OFF 3S and blink 1 times	OFF 3S and blink 1 times				When the outdoor unit receive signal of Gathering refrigerant ,the system will be forced to run under cooling mode for gathering refrigerant	Nominal cooling mode	
12	Indoor ambient temperature sensor is open/short circuited	F1		OFF 3S and blink once				During cooling and drying operation, indoor unit operates while other loads will stop; during heating operation, the complete unit will stop operation.	1. Loosening or bad contact of indoor ambient temp. sensor and mainboard terminal. 2. Components in mainboard fell down leads short circuit. 3. Indoor ambient temp. sensor damaged.(check with sensor resistance value chart) 4. Mainboard damaged.	
13	Indoor evaporator temperature sensor is open/short circuited	F2		OFF 3S and blink twice				AC stops operation once reaches the setting temperature. Cooling, drying: internal fan motor stops operation while other loads stop operation; heating: AC stop operation	1. Loosening or bad contact of Indoor evaporator temp. sensor and mainboard terminal. 2. Components on the mainboard fall down leads short circuit. 3. Indoor evaporator temp. sensor damaged.(check temp. sensor value chart for testing) 4. Mainboard damaged.	
14	Outdoor ambient temperature sensor is open/short circuited	F3		OFF 3S and blink 3 times			OFF 3S and blink 6 times	During cooling and drying operating, compressor stops while indoor fan operates; During heating operation, the complete unit will stop operation	Outdoor temperature sensor hasnt been connected well or is damaged. Please check it by referring to the resistance table for temperature sensor)	
15	Outdoor condenser temperature sensor is open/short circuited	F4		OFF 3S and blink 4 times			OFF 3S and blink 5 times	During cooling and drying operation, compressor stops while indoor fan will operate; During heating operation, the complete unit will stop operation.	Outdoor temperature sensor hasnt been connected well or is damaged. Please check it by referring to the resistance table for temperature sensor)	
16	Outdoor discharge temperature sensor is open/short circuited	F5		OFF 3S and blink 5 times			OFF 3S and blink 7 times	During cooling and drying operation, compressor will sop after operating for about 3 mins, while indoor fan will operate; During heating operation, the complete unit will stop after operating for about 3 mins.	1.Outdoor temperature sensor hasnt been connected well or is damaged. Please check it by referring to the resistance table for temperature sensor) 2.The head of temperature sensor hasnt been inserted into the copper tube	
17	Limit/ decrease frequency due to overload	F6		OFF 3S and blink for 6 times			OFF 3S and blink 3 times	All loads operate normally, while operation frequency for compressor is decreased	Refer to the malfunction analysis (overload, high temperature resistant)	
18	Decrease frequency due to overcurrent	F8		OFF 3S and blink 8 times			OFF 3S and blink once	All loads operate normally, while operation frequency for compressor is decreased	The input supply voltage is too low; System pressure is too high and overload	



NO.	Malfunction Name	Display Method of Indoor Unit				Display Method of Outdoor Unit			A/C status	Possible Causes	
		Dual-8 Code Display	Indicator Display (during blinking, ON 0.5s and OFF 0.5s)			Indicator has 3 kinds of display status and during blinking, ON 0.5s and OFF 0.5s					
			Operation Indicator	Cool Indicator	Heating Indicator	Yellow Indicator	Red Indicator	Green Indicator			
19	Decrease frequency due to high air discharge	F9		OFF 3S and blink 9 times				OFF 3S and blink twice		All loads operate normally, while operation frequency for compressor is decreased	Overload or temperature is too high; Refrigerant is insufficient; Malfunction of electric expansion valve (EKV)
20	Limit/decrease frequency due to antifreezing	FH		OFF 3S and blink 2 times	OFF 3S and blink 2 times			OFF 3S and blink 4 times		All loads operate normally, while operation frequency for compressor is decreased	Poor air-return in indoor unit or fan speed is too low
21	Voltage for DC bus-bar is too high	PH		OFF 3S and blink 11 times				OFF 3S and blink 13 times		During cooling and drying operation, compressor will stop while indoor fan will operate; During heating operation, the complete unit will stop operation.	1. Measure the voltage of position L and N on wiring board (XT), if the voltage is higher than 265VAC, turn on the unit after the supply voltage is increased to the normal range. 2.If the AC input is normal, measure the voltage of electrolytic capacitor C on control panel (AP1), if its normal, theres malfunction for the circuit, please replace the control panel (AP1)
22	Voltage of DC bus-bar is too low	PL			OFF 3S and blink 21 times			OFF 3S and blink 12 times		During cooling and drying operation, compressor will stop while indoor fan will operate; During heating operation, the complete unit will stop	1. Measure the voltage of position L and N on wiring board (XT), if the voltage is higher than 150VAC, turn on the unit after the supply voltage is increased to the normal range. 2.If the AC input is normal, measure the voltage of electrolytic capacitor C on control panel (AP1), if its normal, theres malfunction for the circuit, please replace the control panel (AP1)
23	Compressor Min frequency in test state	P0		(during blinking, ON 0.25s and OFF 0.25s)	(during blinking, ON 0.25s and OFF 0.25s)						Showing during min. cooling or min. heating test
24	Compressor rated frequency in test state	P1		(during blinking, ON 0.25s and OFF 0.25s)	(during blinking, ON 0.25s and OFF 0.25s)						Showing during nominal cooling or nominal heating test
25	Compressor maximum frequency in test state	P2		(during blinking, ON 0.25s and OFF 0.25s)	(during blinking, ON 0.25s and OFF 0.25s)						Showing during max. cooling or max. heating test

NO.	Malfunction Name	Display Method of Indoor Unit			Display Method of Outdoor Unit			A/C status	Possible Causes	
		Dual-8 Code Display	Indicator Display (during blinking, ON 0.5s and OFF 0.5s)			Indicator has 3 kinds of display status and during blinking, ON 0.5s and OFF 0.5s				
			Operation Indicator	Cool Indicator	Heating Indicator	Yellow Indicator	Red Indicator			Green Indicator
26	Compressor intermediate frequency in test state	P3		(during blinking, ON 0.25s and OFF 0.25s)	(during blinking, ON 0.25s and OFF 0.25s)				Showing during middle cooling or middle heating test	
27	Overcurrent protection of phase current for compressor	P5		OFF 3S and blink 15 times				During cooling and drying operation, compressor will stop while indoor fan will operate; During heating operation, the complete unit will stop operation.	Refer to the malfunction analysis (IPM protection, loss of synchronism protection and overcurrent protection of phase current for compressor.	
28	Charging malfunction of capacitor	PU			OFF 3S and blink 17 times			During cooling and drying operation, compressor will stop while indoor fan will operate; During heating operation, the complete unit will stop	Refer to the part three—charging malfunction analysis of capacitor	
29	Malfunction of module temperature sensor circuit	P7			OFF 3S and blink 18 times			During cooling and drying operation, compressor will stop while indoor fan will operate; During heating operation, the complete unit will stop	Replace outdoor control panel AP1	
30	Module high temperature protection	P8			OFF 3S and blink 19 times			During cooling operation, compressor will stop while indoor fan will operate; During heating operation, the complete unit will stop	After the complete unit is de-energized for 20mins, check whether the thermal grease on IPM Module of outdoor control panel AP1 is sufficient and whether the radiator is inserted tightly. If its no use, please replace control panel AP1.	
31	Decrease frequency due to high temperature resistant during heating operation	H0			OFF 3S and blink 10 times			All loads operate normally, while operation frequency for compressor is decreased	Refer to the malfunction analysis (overload, high temperature resistant)	
32	Static dedusting protection	H2			OFF 3S and blink twice					
33	Overload protection for compressor	H3			OFF 3S and blink 3 times	OFF 3S and blink 8 times		During cooling and drying operation, compressor will stop while indoor fan will operate; During heating operation, the complete unit will stop operation.	1. Wiring terminal OVC-COMP is loosened. In normal state, the resistance for this terminal should be less than 1ohm. 2. Refer to the malfunction analysis (discharge protection, overload)	



NO.	Malfunction Name	Display Method of Indoor Unit			Display Method of Outdoor Unit			A/C status	Possible Causes	
		Dual-8 Code Display	Indicator Display (during blinking, ON 0.5s and OFF 0.5s)			Indicator has 3 kinds of display status and during blinking, ON 0.5s and OFF 0.5s				
			Operation Indicator	Cool Indicator	Heating Indicator	Yellow Indicator	Red Indicator	Green Indicator		
34	System is abnormal	H4			OFF 3S and blink 4 times	OFF 3S and blink 6 times			During cooling and drying operation, compressor will stop while indoor fan will operate; During heating operation, the complete unit will stop operation.	Refer to the malfunction analysis (overload, high temperature resistant)
35	IPM protection	H5			OFF 3S and blink 5 times	OFF 3S and blink 4 times			During cooling and drying operation, compressor will stop while indoor fan will operate; During heating operation, the complete unit will stop operation.	Refer to the malfunction analysis (IPM protection, loss of synchronism protection and overcurrent protection of phase current for compressor.
36	Module temperature is too high	H5			OFF 3S and blink 5 times	OFF 3S and blink 10 times				
37	Internal motor (fan motor) do not operate	H6	OFF 3S and blink 11 times						Internal fan motor, external fan motor, compressor and electric heater stop operation, guide louver stops at present location.	1. Bad contact of DC motor feedback terminal. 2. Bad contact of DC motor control end. 3. Fan motor is stalling. 4. Motor malfunction. 5. Malfunction of mainboard rev detecting circuit.
38	Desynchronizing of compressor	H7			OFF 3S and blink 7 times				During cooling and drying operation, compressor will stop while indoor fan will operate; During heating operation, the complete unit will stop operation.	Refer to the malfunction analysis (IPM protection, loss of synchronism protection and overcurrent protection of phase current for compressor.
39	PFC protection	HC			OFF 3S and blink 6 times	OFF 3S and blink 14 times			During cooling and drying operation, compressor will stop while indoor fan will operate; During heating operation, the complete unit will stop operation.	Refer to the malfunction analysis
40	Outdoor DC fan motor malfunction	L3	OFF 3S and blink 23 times				OFF 3S and blink 14 times		Outdoor DC fan motor malfunction lead to compressor stop operation,	DC fan motor malfunction or system blocked or the connector loosed
41	power protection	L9	OFF 3S and blink 20 times				OFF 3S and blink 9 times		compressor stop operation and Outdoor fan motor will stop 30s latter , 3 minutes latter fan motor and compressor will restart	To protect the electrical components when detect high power
42	Indoor unit and outdoor unit doesn't match	LP	OFF 3S and blink 19 times				OFF 3S and blink 16 times		compressor and Outdoor fan motor can't work	Indoor unit and outdoor unit doesn't match
43	Failure start-up	LC			OFF 3S and blink 11 times				During cooling and drying operation, compressor will stop while indoor fan will operate; During heating operation, the complete unit will stop operation.	Refer to the malfunction analysis

NO.	Malfunction Name	Display Method of Indoor Unit			Display Method of Outdoor Unit			A/C status	Possible Causes	
		Dual-8 Code Display	Indicator Display (during blinking, ON 0.5s and OFF 0.5s)			Indicator has 3 kinds of display status and during blinking, ON 0.5s and OFF 0.5s				
			Operation Indicator	Cool Indicator	Heating Indicator	Yellow Indicator	Red Indicator			Green Indicator
44	Malfunction of phase current detection circuit for compressor	U1			OFF 3S and blink 13 times				During cooling and drying operation, compressor will stop while indoor fan will operate; During heating operation, the complete unit will stop	Replace outdoor control panel AP1
45	Malfunction of voltage dropping for DC bus-bar	U3			OFF 3S and blink 20 times				During cooling and drying operation, compressor will stop while indoor fan will operate; During heating operation, the complete unit will stop	Supply voltage is unstable
46	Malfunction of complete units current detection	U5			OFF 3S and blink 13 times				During cooling and drying operation, the compressor will stop while indoor fan will operate; During heating operating, the complete unit will stop operation.	Theres circuit malfunction on outdoor units control panel AP1, please replace the outdoor units control panel AP1.
47	The four-way valve is abnormal	U7			OFF 3S and blink 20 times				If this malfunction occurs during heating operation, the complete unit will stop operation.	1.Supply voltage is lower than AC175V; 2.Wiring terminal 4V is loosened or broken; 3.4V is damaged, please replace 4V.
48	Zero-crossing malfunction of outdoor unit	U9			OFF 3S and blink 18 times				During cooling operation, compressor will stop while indoor fan will operate; during heating,the complete unit will stop operation.	Replace outdoor control panel AP1
49	Frequency limiting (power)						OFF 3S and blink 13 times			
50	Compressor is open-circuited					OFF 3S and blink once				
51	The temperature for turning on the unit is reached						OFF 3S and blink 8 times			
52	Frequency limiting (module temperature)						OFF 3S and blink 11 times			