

A decorative graphic consisting of a series of dots forming an arrow shape, transitioning from grey to orange.

Service Manual

**MODEL: GWH18UC-K3DNA1A
GWH18UC-K3DNA2A
(Refrigerant R410A)**

GREE ELECTRIC APPLIANCES INC.OF ZHUHAI

Table of Contents

Summary and Features	1
1. Safety Precautions	2
2. Specifications	3
2.1 Unit Specifications.....	3
2.2 Operation Characteristic Curve.....	5
2.3 Capacity Variation Ratio According to Temperature.....	5
2.4 Noise Criteria Curve Tables for Both Models.....	6
2.5 Operation Data.....	6
3. Construction Views	7
3.1 Indoor Unit.....	7
3.2 Outdoor Unit.....	7
4. Refrigerant System Diagram	8
5. Schematic Diagram	9
5.1 Electrical Wiring.....	9
5.2 Printed Circuit Board.....	11
6. Function and Control	13
6.1 Remote Control Operations.....	13
6.2 Description of Each Control Operation.....	16
7. Installation Manual	21
7.1 Notices for Installation.....	21
7.2 Installation Drawing.....	23
7.3 Install Indoor Unit.....	24
7.4 Install Outdoor Unit.....	26
7.5 Check after Installation and Operation Test.....	26
7.6 Installation and Maintenance of Healthy Filter.....	27

8. Exploded Views and Parts List	28
8.1 Indoor Unit.....	28
8.2 Outdoor Unit.....	32
9. Troubleshooting	34
9.1 Malfunction Analysis	34
9.2 Flashing LED of Indoor/Outdoor Unit and Primary Judgement.....	38
9.3 How to Check Simply The Main Part.....	41
10. Removal Procedure	52
10.1 Removal Procedure of Indoor Unit.....	52
10.2 Removal Procedure of Outdoor Unit	57

Summary and Features

Indoor Unit

GWH18UC-K3DNA1A/I

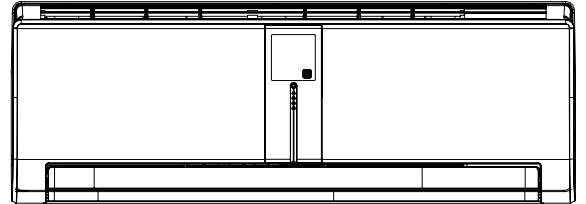

GWH18UC-K3DNA2A/I

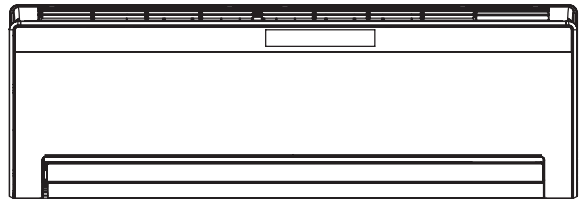

Outdoor Unit

GWH18UC-K3DNA1A/O

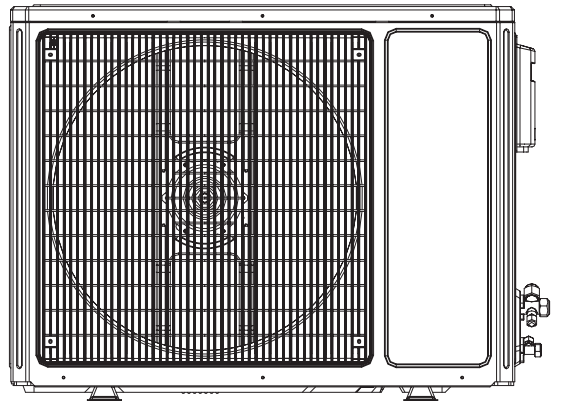

Remote Controller

YAA1FB1

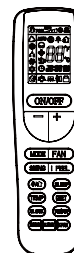

1. Safety Precautions

Installing, starting up, and servicing air conditioner can be hazardous due to system pressure, electrical components, and equipment location, etc.

Only trained, qualified installers and service personnel are allowed to install, start-up, and service this equipment.

Untrained personnel can perform basic maintenance functions such as cleaning coils. All other operations should be performed by trained service personnel.

When handling the equipment, observe precautions in the manual and on tags, stickers, and labels attached to the equipment. Follow all safety codes. Wear safety glasses and work gloves. Keep quenching cloth and fire extinguisher nearby when brazing.

Read the instructions thoroughly and follow all warnings or cautions in literature and attached to the unit. Consult local building codes and current editions of national as well as local electrical codes.

Recognize the following safety information:

 **Warning** Incorrect handling could result in personal injury or death.

 **Caution** Incorrect handling may result in minor injury, or damage to product or property.

 **Warning**

All electric work must be performed by a licensed technician according to local regulations and the instructions given in this manual.

- Before installing, modifying, or servicing system, main electrical disconnect switch must be in the OFF position. There may be more than 1 disconnect switch. Lock out and tag switch with a suitable warning label.
- Never supply power to the unit unless all wiring and tubing are completed, reconnected and checked.
- This system adopts highly dangerous electrical voltage. Incorrect connection or inadequate grounding can cause personal injury or death. Stick to the wiring diagram and all the instructions when wiring.
- Have the unit adequately grounded in accordance with local electrical codes.
- Have all wiring connected tightly. Loose connection may lead to overheating and a possible fire hazard.

All installation or repair work shall be performed by your dealer or a specialized subcontractor as there is the risk of fire, electric shock, explosion or injury.

- Make sure the outdoor unit is installed on a stable, level surface with no accumulation of snow, leaves, or trash beside.

- Make sure the ceiling/wall is strong enough to bear the weight of the unit.

- Make sure the noise of the outdoor unit does not disturb neighbors.

- Follow all the installation instructions to minimize the risk of damage from earthquakes, typhoons or strong winds.

- Avoid contact between refrigerant and fire as it generates poisonous gas.

- Apply specified refrigerant only. Never have it mixed with any other refrigerant. Never have air remain in the refrigerant line as it may lead to rupture and other hazards.

- Make sure no refrigerant gas is leaking out when installation is completed.

- Should there be refrigerant leakage, the density of refrigerant in the air shall in no way exceed its limited value, or it may lead to explosion.

- Keep your fingers and clothing away from any moving parts.

- Clear the site after installation. Make sure no foreign objects are left in the unit.

- Always ensure effective grounding for the unit.

 **Caution**

- Never install the unit in a place where a combustible gas might leak, or it may lead to fire or explosion.

- Make a proper provision against noise when the unit is installed at a telecommunication center or hospital.

- Provide an electric leak breaker when it is installed in a watery place.

- Never wash the unit with water.

- Handle unit transportation with care. The unit should not be carried by only one person if it is more than 20kg.

- Never touch the heat exchanger fins with bare hands.

- Never touch the compressor or refrigerant piping without wearing glove.

- Do not have the unit operate without air filter.

- Should any emergency occur, stop the unit and disconnect the power immediately.

- Properly insulate any tubing running inside the room to prevent the water from damaging the wall.

2. Specifications

2.1 Unit Specifications

Parameter	Unit	Value	
Model		GWH18UC-K3DNA1A GWH18UC-K3DNA2A	
Product Code		CB204000600 CB221000600	
Power Supply	Rated Voltage	V ~ 220-240	
	Rated Frequency	Hz 50	
	Phases	1	
Power Supply Mode		Indoor	
Cooling Capacity (Min ~ Max)	W	5300(1500 ~ 6000)	
Heating Capacity (Min ~ Max)	W	5600(1500 ~ 6350)	
Cooling Power Input (Min ~ Max)	W	1550(580 ~ 2450)	
Heating Power Input (Min ~ Max)	W	1550(520 ~ 2650)	
Cooling Power Current	A	6.80	
Heating Power Current	A	6.80	
Rated Input	W	2650	
Rated Current	A	11.60	
Air Flow Volume(SH/H/MH/M/L/ML/SL)	m ³ /h	850/800/750/680/600/550/450	
Dehumidifying Volume	L/h	1.8	
EER	W/W	3.41	
COP	W/W	3.61	
SEER	W/W	-	
HSPF	W/W	-	
Application Area	m ²	23-34	
Indoor Unit	Model of indoor unit		GWH18UC-K3DNA1A/I GWH18UC-K3DNA2A/I
	Fan Type		Cross-flow
	Diameter Length(DXL)	mm	Φ98X765
	Fan Motor Cooling Speed (SH/H/MH/M/L/ML/SL)	r/min	1400/1150/1070/1000/950/900/850
	Fan Motor Heating Speed (SH/H/MH/M/L/ML/SL)	r/min	1400/1150/1080/1020/950/900/850
	Output of Fan Motor	W	35
	Fan Motor RLA	A	0.32
	Fan Motor Capacitor	μF	2.5
	Input of Heater	W	-
	Evaporator Form		Aluminum Fin-copper Tube
	Pipe Diameter	mm	Φ7
	Row-fin Gap	mm	2-1.5
	Coil Length (LXDXW)	mm	770X25.4X343
	Swing Motor Model		MP24HA/MP24HB
	Output of Swing Motor	W	2.5
	Fuse	A	3.15
	Sound Pressure Level(SH/H/MH/M/L/ML/SL)	dB (A)	45/40/37/35/33/31/28
	Sound Power Level(SH/H/MH/M/L/ML/SL)	dB (A)	55/50/47/45/43/41/38
	Dimension (WXHXD)	mm	998X340X178
	Dimension of Carton Box (LXWXH)	mm	1080X425X268
	Dimension of Package (LXWXH)	mm	1083X428X283
	Net Weight	kg	15
	Gross Weight	kg	19

Outdoor Unit	Model of Outdoor Unit		GWH18UC-K3DNA1A/O	
	Compressor Manufacturer/Trademark		MITSUBISHI ELECTRIC (GUANGZHOU) COMPRESSOR CO. LTD/MITSUBISHI	
	Compressor Model		SNB130FGYMC	
	Compressor Oil		FV50S	
	Compressor Type		Rotary	
	L.R.A.	A		27.00
	Compressor RLA	A		8.40
	Compressor Power Input	W		1245
	Overload Protector			1NT11L-6578
	Throttling Method			Capillary
	Operation temp	°C		16 ~ 30
	Ambient temp (cooling)	°C		18 ~ 43
	Ambient temp (heating)	°C		-7 ~ 24
	Condenser Form			Aluminum Fin-copper Tube
	Pipe Diameter	mm		Φ7
	Rows-fin Gap	mm		3-1.4
	Coil Length (LXD _X W)	mm		825X38.1X666
	Fan Motor Speed	rpm		850/700/660
	Output of Fan Motor	W		60
	Fan Motor RLA	A		0.58
	Fan Motor Capacitor	μF		-
	Air Flow Volume of Outdoor Unit	m ³ /h		3200
	Fan Type			Axial-flow
	Fan Diameter	mm		520
	Defrosting Method			Automatic Defrosting
	Climate Type			T1
	Isolation			I
	Moisture Protection			IP24
	Permissible Excessive Operating Pressure for the Discharge Side	MPa		3.8
	Permissible Excessive Operating Pressure for the Suction Side	MPa		1.2
	Sound Pressure Level (H/M/L)	dB (A)		56/-/-
Sound Power Level (H/M/L)	dB (A)		66/-/-	
Dimension (WXHXD)	mm		955X700X396	
Dimension of Carton Box (L/W/H)	mm		1026X455X735	
Dimension of Package (L/W/H)	mm		1029X458X750	
Net Weight	kg		50	
Gross Weight	kg		55	
Refrigerant			R410A	
Refrigerant Charge	kg		1.50	
Connection Pipe	Length	m	5	
	Gas Additional Charge	g/m	20	
	Outer Diameter Liquid Pipe	mm	Φ6	
	Outer Diameter Gas Pipe	mm	Φ12	
	Max Distance Height	m	10	
	Max Distance Length	m	25	

The above data is subject to change without notice. Please refer to the nameplate of the unit.

2.2 Operation Characteristic Curve

Cooling

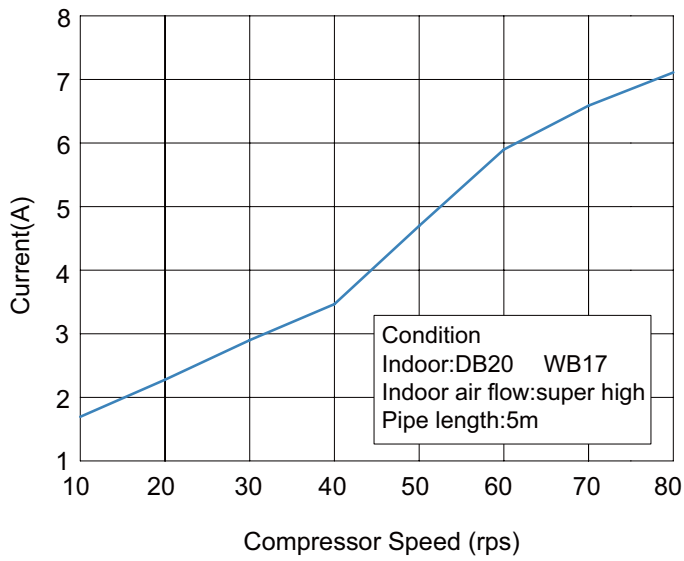

Heating

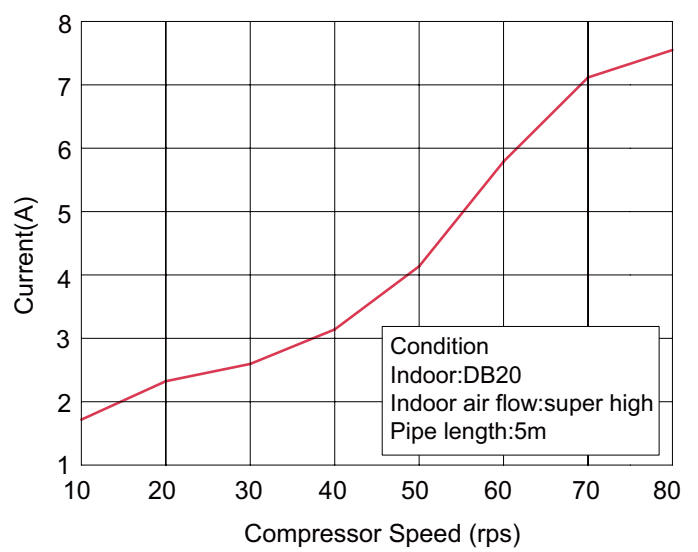

2.3 Capacity Variation Ratio According to Temperature

Cooling

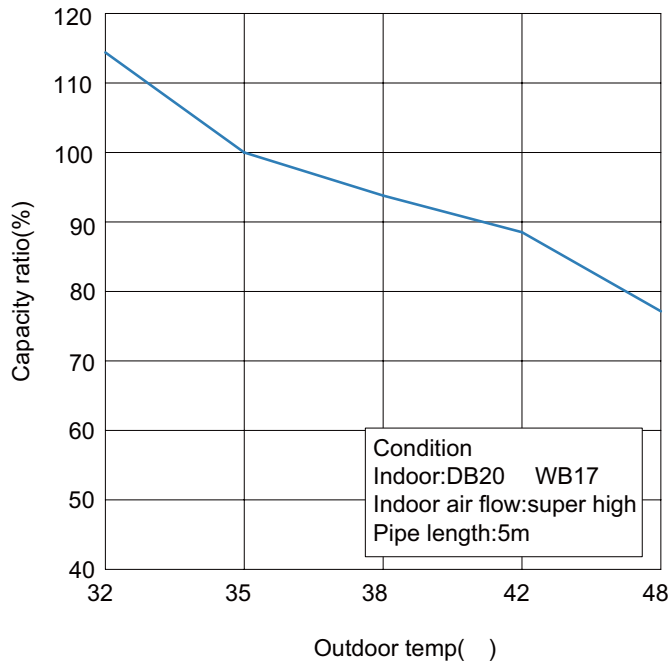

Heating

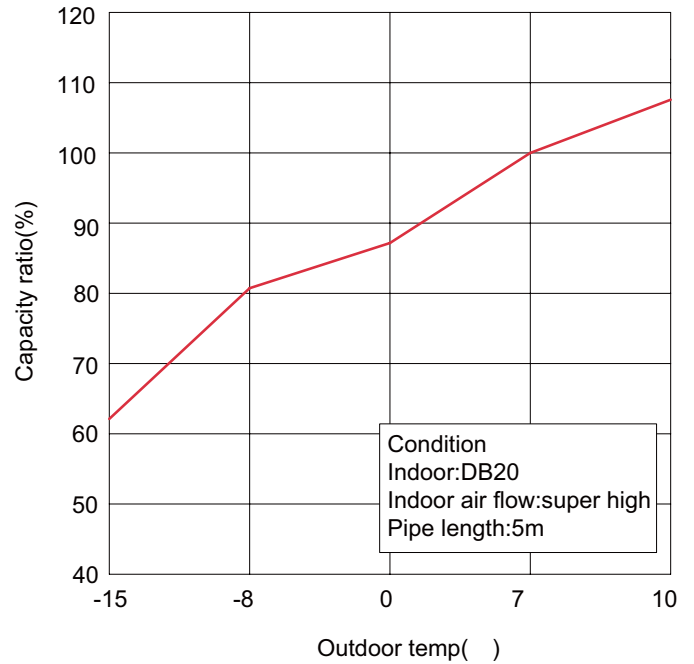

2.4 Noise Criteria Curve Tables for Both Models

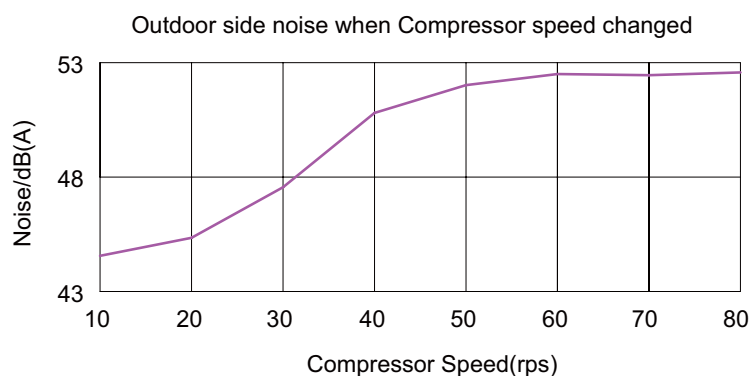
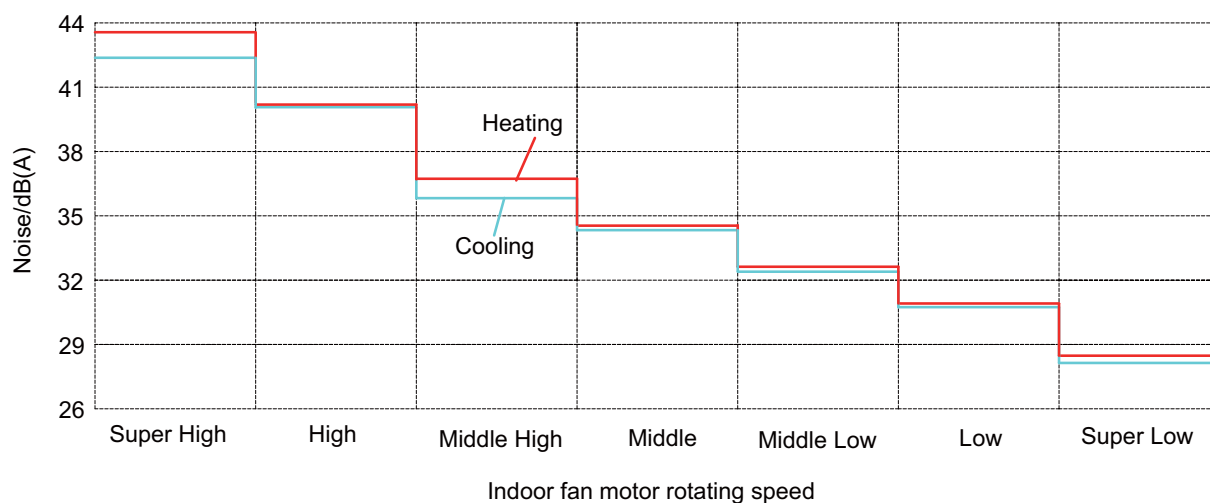

2.5 Operation Data

Cooling

Temperature condition (°C)		Model name	Standard pressure P (MPa)	Heat exchanger pipe temp		Indoor fan mode	Outdoor fan mode	Compressor revolution (rpm)
Indoor	Outdoor			T1 (°C)	T2 (°C)			
27/19	35/24	18K	0.92	8.2 to 10.1	55 to 40	Super High	Super High	69

Heating

Temperature condition (°C)		Model name	Standard pressure P (MPa)	Heat exchanger pipe temp		Indoor fan mode	Outdoor fan mode	Compressor revolution (rpm)
Indoor	Outdoor			T1 (°C)	T2 (°C)			
20/15	7/6	18K	2.98	51 to 38	-1 to 2.5	Super High	Super High	69

T1: Outlet and inlet pipe temperature of evaporator

T2: Outlet and inlet pipe temperature of condenser

P: Pressure of air pipe used for connecting outdoor and indoor units

NOTES :

(1) Measure surface temperature of heat exchanger pipe around center of heat exchanger path U bent. (Thermistor thermometer)

(2) Connecting piping condition :5m

3. Construction Views

3.1 Indoor Unit

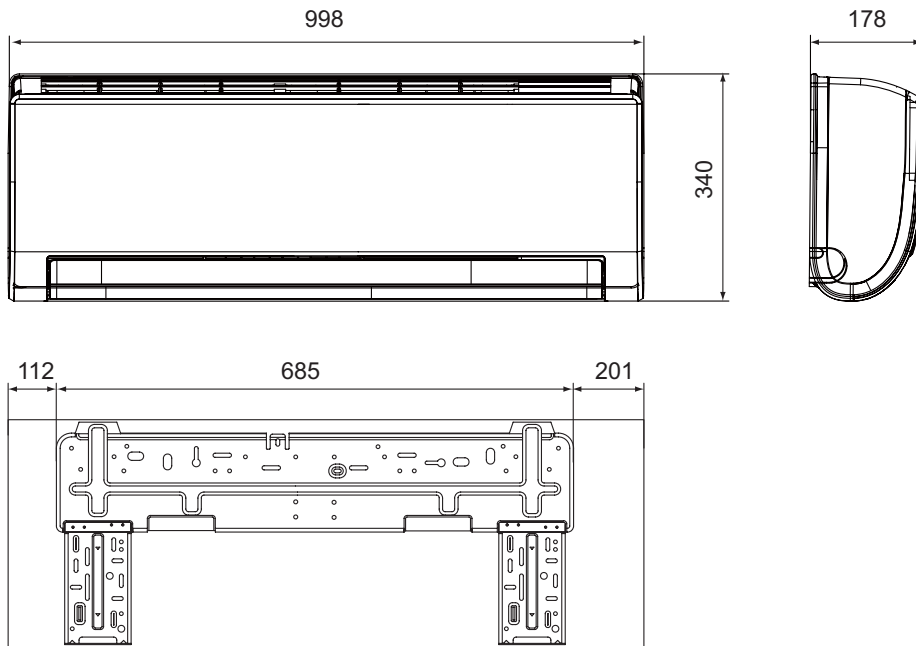

3.2 Outdoor Unit

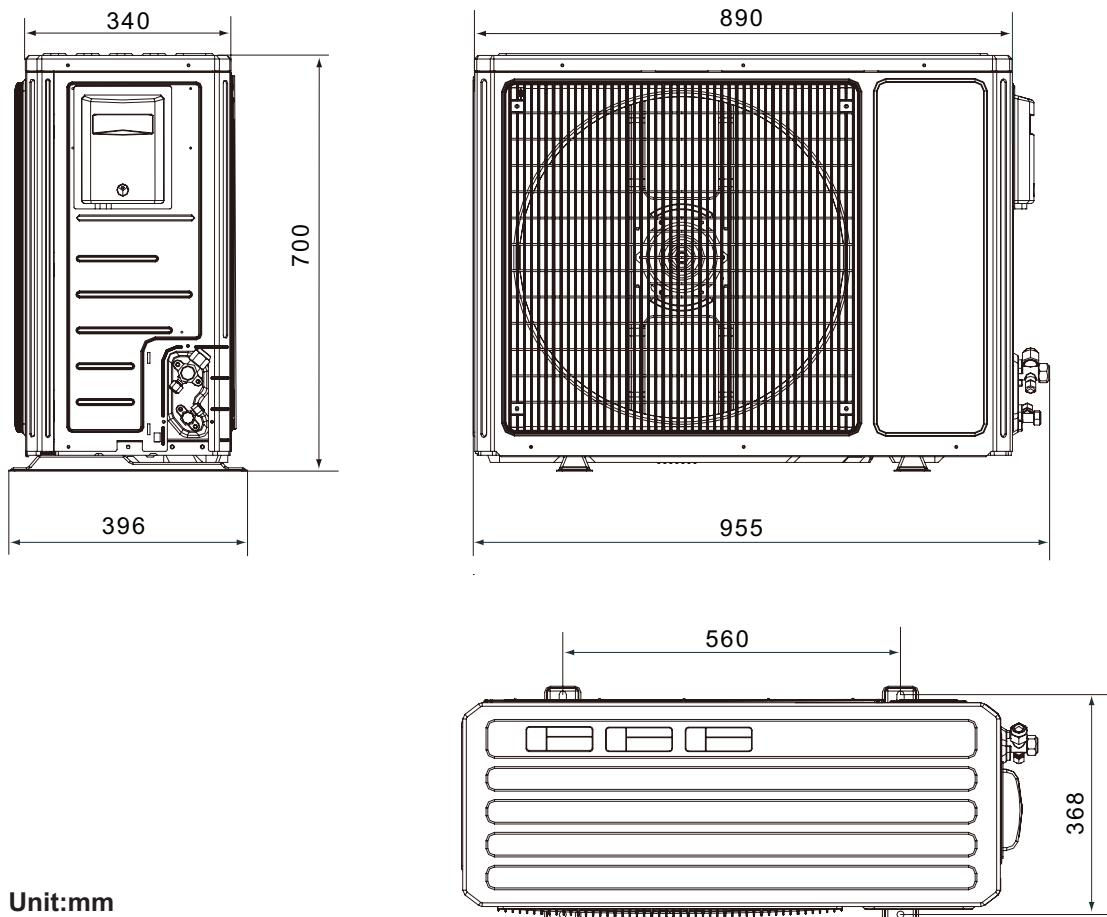

Unit:mm

4. Refrigerant System Diagram

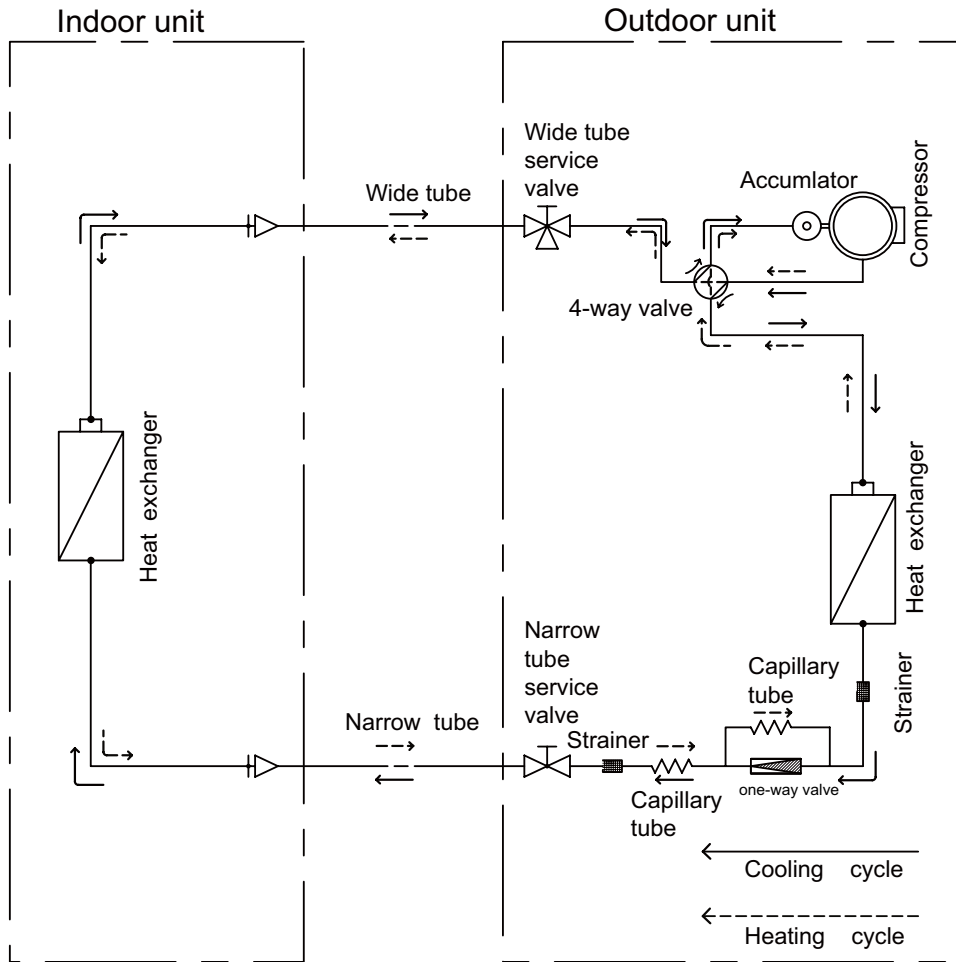

Refrigerant pipe diameter
Liquid : 1/4" (6mm) Gas : 1/2" (12mm)

5. Schematic Diagram

5.1 Electrical Wiring

●Electrical Data(Meaning of marks)

Symbol	Color symbol	Symbol	Parts name
OG	ORANGE		PROTECTIVE EARTH
WH	WHITE	COMP	COMPRESSOR
YE	YELLOW	CT1,2	OVERLOAD
RD	RED	4V	4-WAY VALVE
YEGN	YELLOW GREEN	XT	TERMINAL BLOCK
BN	BROWN		
BU	BLUE		
BK	BLACK		

●Indoor Unit

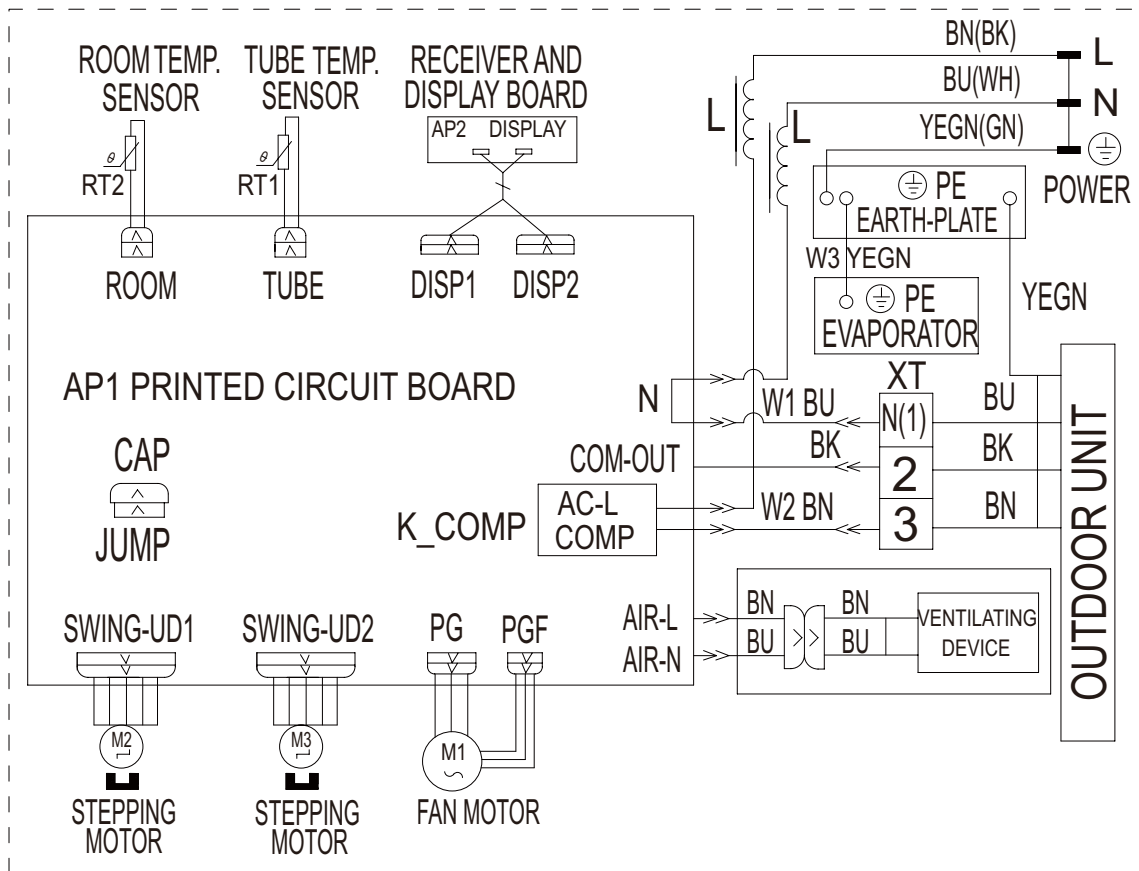

•Outdoor Unit

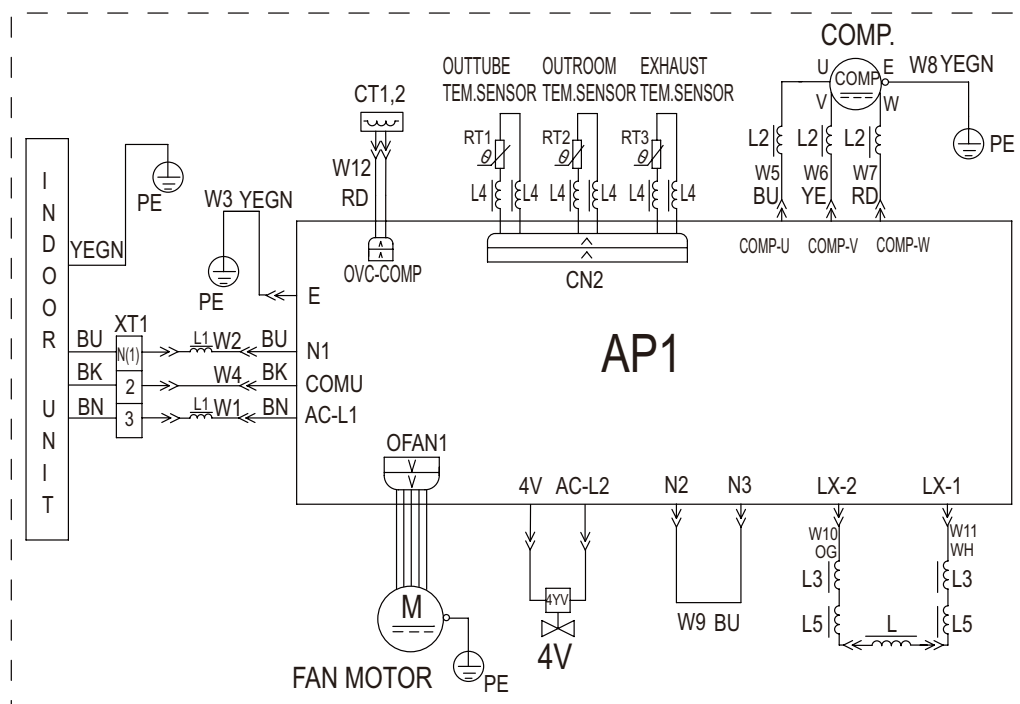

These circuit diagrams are subject to change without notice, please refer to the one supplied with the unit.

5.2 Printed Circuit Board

(1) Indoor Unit

●TOP VIEW

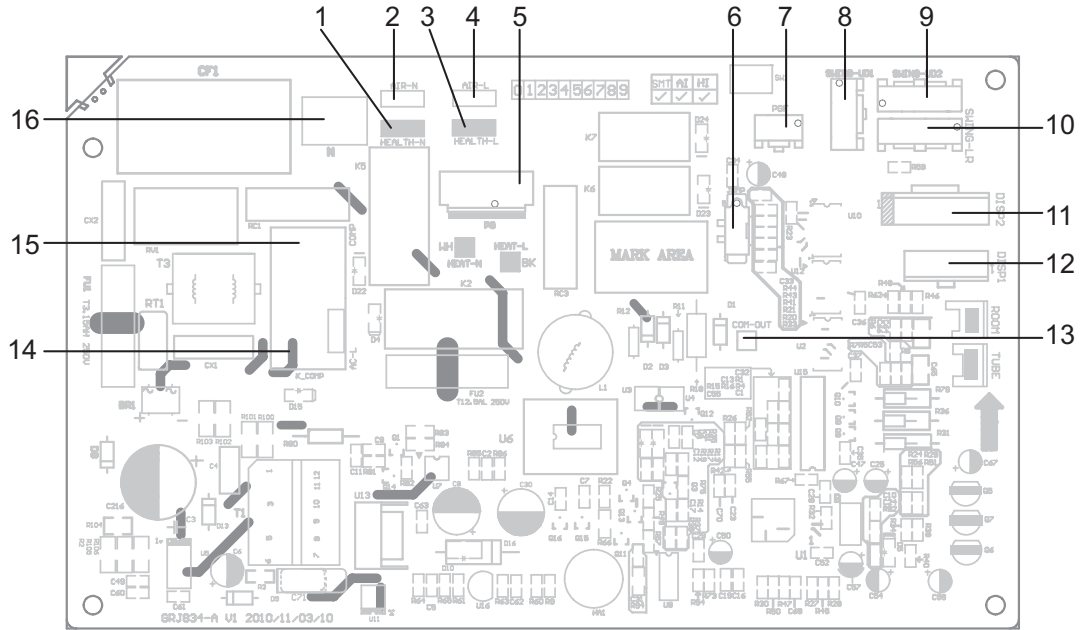

1	Neutral wire terminal of cold plasma	5	Wiring terminal of PG motor	9	Up&down swing terminal 2	13	Terminal of communication wire
2	Neutral wire terminal of air	6	Terminal of jumper cap	10	Up&down swing terminal	14	Terminal of power live wire, connect live wire of power
3	Live wire terminal of cold plasma	7	Feedback terminal of PG motor	11	Seven-needle terminal of display	15	Terminal of power live wire, connect live wire of outdoor unit
4	Live wire terminal of air	8	Up&down swing terminal 1	12	Six-needle terminal of display	16	Terminal of power live wire

●BOTTOM VIEW

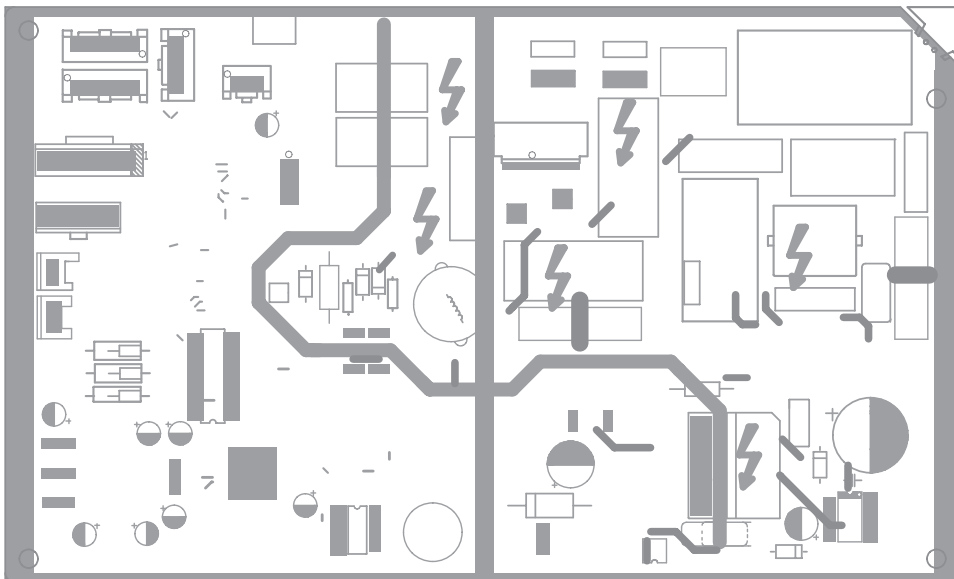

(2)Outdoor Unit

•TOP VIEW

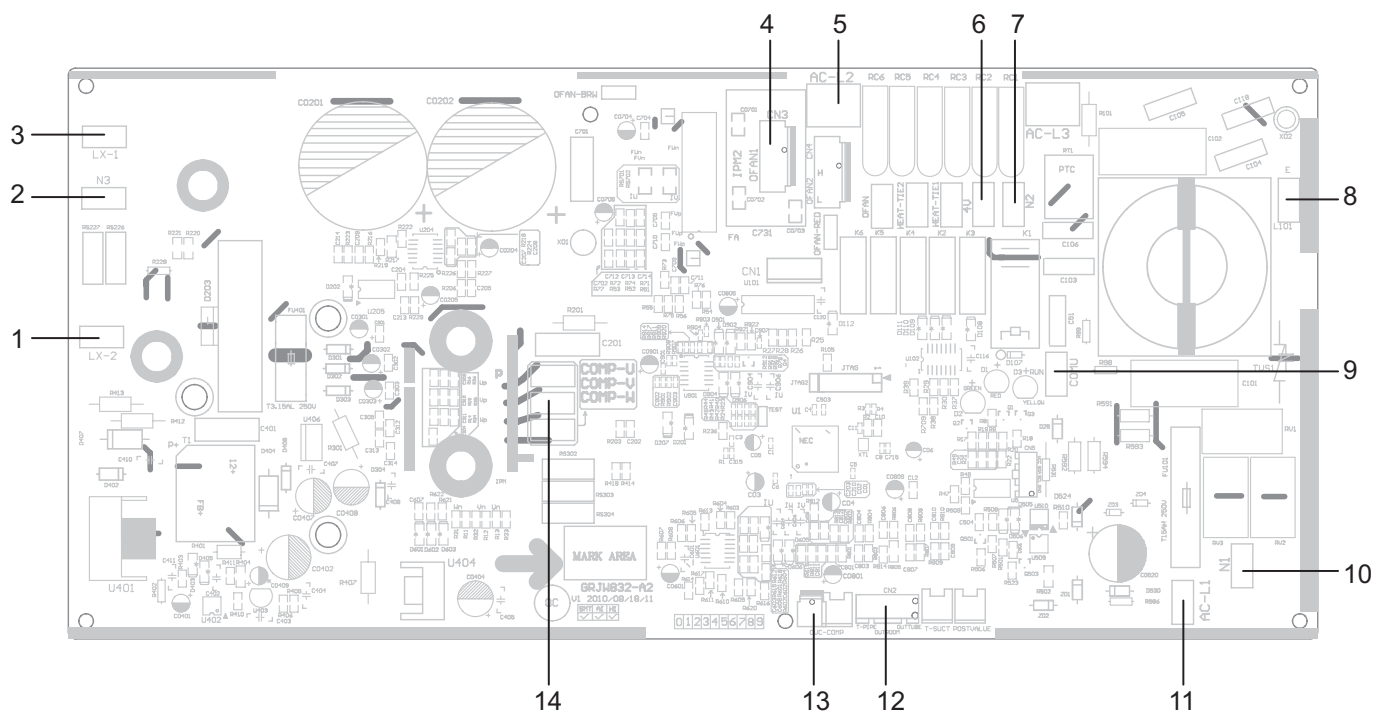

1	Terminal of reactor	5	Terminal of live wire for 4-way valve	9	Terminal of communication wire	13	Terminal of overload protection
2	Jumping terminal of neutral wire	6	Limit terminal of 4-way valve	10	Terminal of neutral wire	14	U,V,W three-phase wiring terminal of compressor
3	Terminal of reactor	7	Jumping terminal of neutral wire	11	Terminal of live wire	15	/
4	Terminal of DC fan	8	Terminal of earthing wire	12	Terminal of discharge temperature sensor of compressor, outdoor ambient temperature sensor and outdoor tube temperature sensor	16	/

•BOTTOM VIEW

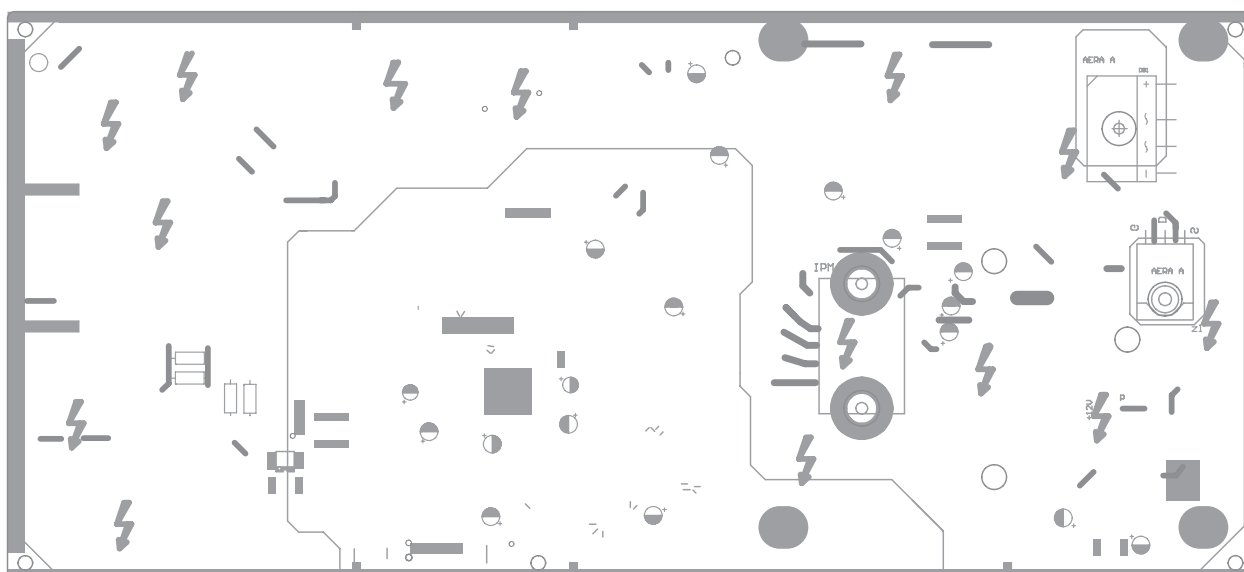

6. Function and Control

6.1 Remote Control Operations



- 1 ON/OFF**
Press it to start or stop operation.
- 2 -**
Press it to decrease temperature setting.
- 3 +**
Press it to increase temperature setting.
- 4 MODE**
Press it to select operation mode(AUTO/COOL/DRY/FAN/HEAT).
- 5 FAN**
Press it to set fan speed.
- 6 SWING**
Press it set swing angle.
- 7 I FEEL**
- 8**
Press it to set HEALTH or AIR function.
- 9 SLEEP**
- 10 TEMP**
- 11 QUIET**
Pressitto set QUIET function.
- 12 CLOCK**
Press it set clock.
- 13 T-ONIT-OFF**
Press it to set auto-off/auto-on timer.
- 14 TURBO**
- 15 LIGHT**
Press it to turn on/off the light.
- 16 X-FAN**

1 ON/OFF

Press this button to turn on the unit .Press this button again to turn off the unit.

2 -

Press this button to decrease set temperature. Holding it down above 2 seconds rapidly decreases set temperature. In AUTO mode, set temperature is not adjustable.

3 +

Press this button to increase set temperature.Holding it down above 2 seconds rapidly increases set temperature. In AUTO mode, set temperature is not adjustable.

4 MODE

Each time you press this button, a mode is selected in a sequence that goes from AUTO, COOL, DRY, FAN, and HEAT *, as the following:



*Note: Only for models with heating function.

After energization, AUTO mode is defaulted. In AUTO mode, the set temperature will not be displayed on the LCD, and the unit will automatically select the suitable operation mode in accordance with the room temperature to make indoor room comfortable.

5 FAN

This button is used for setting Fan Speed in the sequence that goes from AUTO, , , , , , to then back to Auto.

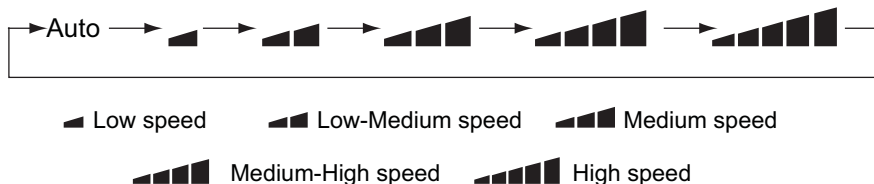

6 SWING

Press this button to set up & down swing angle, which circularly changes as below:



This remote controller is universal. If any command , or is sent out, the unit will carry out the command as indicates the guide louver swings as:

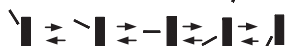

7 I FEEL

Press this button to turn on I FEEL function. The unit automatically adjust temperature according to the sensed temperature. Press this button again to cancel I FEEL function.

8

Press this button to achieve the on and off of healthy and scavenging functions in operation status. Press this button for the first time to start scavenging function; LCD displays " ". Press the button for the second time to start healthy and scavenging functions simultaneously; LCD displays " " and " ". Press this button for the third time to quit healthy and scavenging functions simultaneously. Press the button for the fourth time to start healthy function; LCD display " ". Press this button again to repeat the operation above.

9 SLEEP

- Press this button, can select Sleep 1 (), Sleep 2 (), Sleep 3 () and cancel the Sleep, circulate between these, after electrified, Sleep Cancel is defaulted.
- Sleep 1 is Sleep mode 1, in Cool, Dehumidify modes: sleep status after run for one hour, the main unit setting temperature will increase 1 , setting temperature increased 2 , the unit will run at this setting temperature; In Heat mode: sleep status after run for one hour, the setting temperature will decrease 1 , 2 hours, setting temperature will decrease 2 , then the unit will run at this setting temperature.
- Sleep 2 is sleep mode 2, that is air conditioner will run according to the presetting a group of sleep temperature curve.
- Sleep 3- the sleep curve setting under Sleep mode by DIY:
 - (1) Under Sleep 3 mode, press "Turbo" button for a long time, remote control enters into user individuation sleep setting status, at this time, the time of remote control will display "1hour", the setting temperature "88" will display the corresponding temperature of last setting sleep curve and blink (The first entering will display according to the initial curve setting value of original factory);
 - (2) Adjust "+" and "-" button, could change the corresponding setting temperature, after adjusted, press "Turbo" button for confirmation;
 - (3) At this time, 1hour will be automatically increased at the timer position on the remote control, (that are "2hours" or "3hours" or "8hours"), the place of setting temperature "88" will display the corresponding temperature of last setting sleep curve and blink;
 - (4) Repeat the above step (2) ~ (3) operation, until 8hours temperature setting finished, sleep, curve setting finished, at this time, the remote control will resume the original timer display; temperature display will resume to original setting temperature.
- Sleep3- the sleep curve setting under Sleep mode by DIY could be inquired:

The user could accord to sleep curve setting method to inquire the presetting sleep curve, enter into user individuation sleep setting status, but do not change the temperature, press "Turbo" button directly for confirmation. Note: In the above presetting or enquiry procedure, if continuously within 10s, there is no button pressed, the sleep curve setting status will be automatically quit and resume to display the original displaying. In the presetting or enquiry procedure, press "ON/OFF" button, "Mode" button, "Timer" button or "Sleep" button, the sleep curve setting or enquiry status will quit similarly.

10 TEMP

Press this button, could select displaying the indoor setting temperature or indoor ambient temperature. When the indoor unit firstly power on it will display the setting temperature, if the temperature's displaying status is changed from other status to " ", displays the ambient temperature, 5s later or within 5s, it receives other remote control signal that will return to display the setting temperature. If the users haven't set up the temperature displaying status, that will display the setting temperature.

11 QUIET

Press this button, the Quiet status is under the Auto Quiet mode (display "AUTO" signal) and Quiet mode (display " " signal) and Quiet OFF (there is no signal of " " displayed), after powered on, the Quiet OFF is defaulted. Note: the Quiet function cannot be set up in Fan and Dry mode; Under the Quiet mode (Display " " Under the Quiet mode (Display " " signal), the fan speed is not available.

12 CLOCK

Press CLOCK button, blinking " ". Within 5 seconds, pressing + or - button adjusts the present time. Holding down either button above 2 seconds increases or decreases the time by 1 minute every 0.5 second and then by 10 minutes every 0.5 second. During blinking after setting, press CLOCK button again to confirm the setting, and then " " will be constantly displayed.

13 T-ON/T-OFF

Press T-ON button to initiate the auto-ON timer. To cancel the auto-timer program, simply press this button again. After press of this button, " " disappears and "ON" blink s. 00:00 is displayed for ON time setting. Within 5 seconds, press + or - button to adjust the time value. Every press of either button changes the time setting by 1 minute. Holding down either button rapidly changes the time setting by 1 minute and then 10 minutes. Within 5 Seconds after setting, press TIMER ON button to confirm. Press T-OFF button to initiate the auto-off timer. To cancel the auto-timer program, simply press the button again. TIMER OFF setting is the same as TIMER ON.

14 TURBO

Press this button to activate / deactivate the Turbo function which enables the unit to reach the preset temperature in the shortest time. In COOL mode, the unit will blow strong cooling air at super high fan speed. In HEAT mode, the unit will blow strong heating air at super high fan speed.

15 LIGHT

Press LIGHT button to turn on the display's light and press this button again to turn off the display's light. If the light is turned on, " " is displayed. If the light is turned off, " " disappears.

16 X-FAN

Pressing X-FAN button in COOL or DRY mode, the icon " " is displayed and the indoor fan will continue operation for 10 minutes in order to dry the indoor unit even though you have turned off the unit. After energization, X-FAN OFF is defaulted. X-FAN is not available in AUTO, FAN or HEAT mode.

17 Combination of "+" and "-" buttons: About lock

Press "+" and "-" buttons simultaneously to lock or unlock the keypad. If the remote controller is locked, " " is displayed. In this case, pressing any button, " " blinks three times.

18 Combination of "MODE" and "-" buttons : About switch between Fahrenheit and centigrade At unit OFF, press "MODE" and "-" buttons simultaneously to switch between " " and " " .

19 Combination of "TEMP" and "CLOCK" buttons : About Energy-saving Function

Press "TEMP" and "CLOCK" simultaneously in COOL mode to start energy-saving function. Nixie tube on the remote controller displays "SE". Repeat the operation to quit the function.

20 Combination of "TEMP" and "CLOCK" buttons : About 8 Heating Function

Press "TEMP" and "CLOCK" simultaneously in HEAT mode to start 8 Heating Function Nixie tube on the remote controller displays " " and a selected temperature of " 8 " . (46 if Fahrenheit is adopted). Repeat the operation to quit the function.

21 About Back-lighting Function

The unit lights for 4s when energizing for the first time, and 3s for later press.

Replacement of Batteries

1. Remove the battery cover plate from the rear of the remote controller. (As shown in the figure)
2. Take out the old batteries.
3. Insert two new AAA1.5V dry batteries, and pay attention to the polarity.
4. Reinstall the battery cover plate.

Notes:

- When replacing the batteries, do not use old or different types of batteries,
- If the remote controller will not be used for a long time, please otherwise, it may cause malfunction.
- remove batteries to prevent batteries from leaking.
- The operation should be performed in its receiving range.
- It should be kept 1m away from the TV set or stereo sound sets.
- If the remote controller does not operate normally, please take the batteries out and reinsert them after 30 seconds. If it still can't operate properly, replace the batteries.

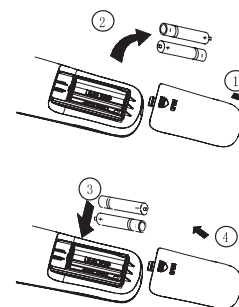

Sketch map for replacing batteries

6.2 Description of Each Control Operation

1. Temperature Parameters

◆ Indoor preset temperature (T_{preset})

◆ Indoor ambient temperature (T_{amb})

2. Basic Functions

Once energized, in no case should the compressor be restarted within less than 3 minutes. In the situation that memory function is available, for the first energization, if the compressor is at stop before de-energization, the compressor will be started without a 3-minute lag; if the compressor is in operation before de-energization, the compressor will be started with a 3-minute lag; and once started, the compressor will not be stopped within 6 minutes regardless of changes in room temperature;

(1) Cooling Mode

① Working conditions and process of cooling

When $T_{\text{amb}} \geq T_{\text{preset}}$, the unit will enter cooling operation, in which case the indoor fan, the outdoor fan and the compressor will work and the indoor fan will run at preset speed.

When $T_{\text{amb}} \leq T_{\text{preset}} - 2^\circ\text{C}$, the compressor will stop, the outdoor fan will stop with a time lag of 30s, and the indoor fan will run at preset speed.

When $T_{\text{preset}} - 2^\circ\text{C} < T_{\text{amb}} < T_{\text{preset}} + 1^\circ\text{C}$, the unit will remain at its previous state.

Under this mode, the four-way valve will be de-energized and temperature can be set within a range from 16 to 30°C .

If the compressor is shut down for some reason, the indoor fan and the swing device will operate at original state.

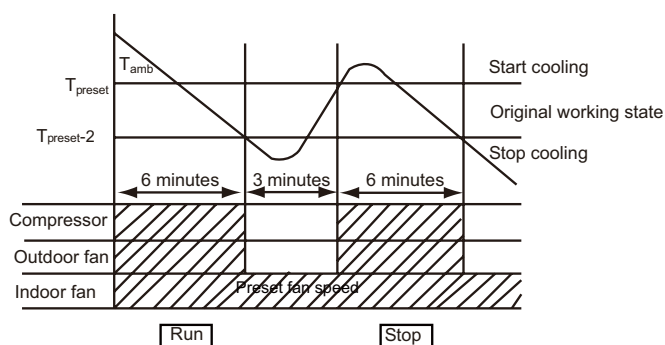

② Protection

◆ Freeze protection

Under cooling and dryingmode, 6 minutes after the compressor is started:

If $T_{\text{evap}} \leq 2^\circ\text{C}$, the compressor will operate at reduced frequency.

If $T_{\text{evap}} \leq -1^\circ\text{C}$ is detected for durative 3 minutes, the compressor will stop, and after 30 seconds, the outdoor fan will stop; and under cooling mode, the indoor fan and the swing motor will remain at the original state.

If $T_{\text{evap}} \geq 6^\circ\text{C}$ and the compressor has remained at OFF for at least 3 minutes, the compressor will resume its original operation state.

◆ Total current up and frequency down protection

If $I_{\text{total}} \leq 9\text{A}$, frequency rise will be allowed; if $I_{\text{total}} \geq 10\text{A}$, frequency rise will not be allowed; if $I_{\text{total}} \geq 11\text{A}$, the compressor will run at reduced frequency; and if $I_{\text{total}} \geq 13\text{A}$, the compressor will stop and the outdoor fan will stop with a time lag of 30s.

(2) Drying Mode

① Working conditions and process of drying

If $T_{\text{amb}} > T_{\text{preset}}$, the unit will enter cooling and dryingmode, in which case the compressor and the outdoor fan will operate and the indoor fan will run at low speed.

If $T_{\text{preset}} - 2^\circ\text{C} \leq T_{\text{amb}} \leq T_{\text{preset}}$, the compressor remains at its original operation state.

If $T_{\text{amb}} < T_{\text{preset}} - 2^\circ\text{C}$, the compressor will stop, the outdoor fan will stop with a time lag of 30s, and the indoor fan will operate at low speed.

② Protection

Protection is the same as that under the cooling mode.

(3) Heating Mode

① Working conditions and process of heating

If $T_{\text{amb}} \leq T_{\text{preset}} + 2^\circ\text{C}$, the unit enters heating mode, in which case the four-way valve, the compressor and the outdoor fan will operate simultaneously, and the indoor fan will run at preset speed in the condition of preset cold air prevention.

If $T_{\text{amb}} \geq T_{\text{preset}} + 5^\circ\text{C}$, the compressor will stop, the outdoor fan will stop with a time lag of 30s, and the indoor fan will stop after 60-second blow at low speed

If $T_{\text{preset}} + 2^\circ\text{C} < T_{\text{amb}} < T_{\text{preset}} + 5^\circ\text{C}$, the unit will maintain its original operating status.

Under this mode, the four-way valve is energized and temperature can be set within a range of 16 - 30°C . The operating symbol, the heating symbol and preset temperature are revealed on the display.

② Condition and process of defrost

When duration of successive heating operation is more than 45 minutes, or accumulated heating time more than 90 minutes, and one of the following conditions is reached, the unit will enter the defrost mode after 3 minutes.

- (1). $T_{\text{outdoor ambient}} > 5^{\circ}\text{C}$, $T_{\text{outdoor tube}} \leq -2^{\circ}\text{C}$;
- (2) $-2^{\circ}\text{C} \leq T_{\text{outdoor ambient}} < 5^{\circ}\text{C}$, $T_{\text{outdoor tube}} \leq -6^{\circ}\text{C}$;
- (3) $-5^{\circ}\text{C} \leq T_{\text{outdoor ambient}} < -2^{\circ}\text{C}$, $T_{\text{outdoor tube}} \leq -10^{\circ}\text{C}$;
- (4) $-10^{\circ}\text{C} \leq T_{\text{outdoor ambient}} < -5^{\circ}\text{C}$, $T_{\text{outdoor tube}} \leq (T_{\text{outdoor ambient}} - 6)^{\circ}\text{C}$.

At that time, the indoor fan stops and the compressor stops, and after 30 seconds the outer fan will stop, and then after 30 seconds, the four-way valve will stop. After 30 seconds, the compressor is initiated for raising the frequency to defrost frequency.

When the compressor has operated under defrost mode for 7.5 minutes, or $T_{\text{outdoor amb}} < -10^{\circ}\text{C}$, $T_{\text{outdoor tube}} \leq (T_{\text{outdoor amb}} - 4)^{\circ}\text{C}$, the compressor will be converted to 53Hz operation. After 30 seconds, the compressor will stop. And after another 30 seconds, the four-way valve will be opened, and after 60 seconds, the compressor and the outer fan will be started, the indoor fan will run under preset cold air prevention conditions, and H1 will be displayed at temperature display area on the display panel. Defrost frequency is 70Hz.

③ Protection

◆ Cold air prevention

The unit is started under heating mode (the compressor is ON):

① In the case of $T_{\text{indoor amb.}} < 24^{\circ}\text{C}$: if $T_{\text{tube}} \leq 40^{\circ}\text{C}$ and the indoor fan is at stop state, the indoor fan will begin to run at low speed with a time lag of 2 minutes. Within 2 minutes, if $T_{\text{tube}} > 40^{\circ}\text{C}$, the indoor fan also will run at low speed; and after 1-minute operation at low speed, the indoor fan will be converted to operation at preset speed. Within 1-minute low speed operation or 2-minute non-operation, if $T_{\text{tube}} > 42^{\circ}\text{C}$, the fan will run at present speed.

② In the case of $T_{\text{indoor amb.}} \geq 24^{\circ}\text{C}$: if $T_{\text{tube}} \leq 42^{\circ}\text{C}$, the indoor fan will run at low speed, and after one minute, the indoor fan will be converted to preset speed. Within one-minute low speed operation, if $T_{\text{tube}} > 42^{\circ}\text{C}$, the indoor fan will be converted to preset speed.

Note: $T_{\text{indoor amb.}}$ indicated in ① and ② refers to, under initially heating mode, the indoor ambient temperature before the command to start the compressor is performed according to the program, or after the unit is withdrawn from defrost, the indoor ambient temperature before the defrost symbol is cleared.

◆ Total current up and frequency down protection

If the total current $I_{\text{total}} \leq 9\text{A}$, frequency rise will be allowed; if $I_{\text{total}} \geq 10\text{A}$, frequency rise will not be allowed; if $I_{\text{total}} \geq 11\text{A}$, the compressor will run at reduced frequency; and if $I_{\text{total}} \geq 13\text{A}$, the compressor will stop and the outdoor fan will stop with a time lag of 30s.

(4) Fan Mode

Under the mode, the indoor fan will run at preset speed and the compressor, the outdoor fan, the four-way valve and the electric heater will stop.

Under the mode, temperature can be set within a range of 16 - 30°C .

(5) AUTO Mode

① Working conditions and process of AUTO mode

a. When $T_{\text{ambient}} \geq 26^{\circ}\text{C}$, the unit will operate in Cool mode. The set temperature is 25°C .

b. When $T_{\text{ambient}} \leq 22^{\circ}\text{C}$, the heat pump unit will operate in Heat mode., set temperature be 20°C ; the cooling only unit will operate in Fan mode, set temperature be 25°C .

c. When $23^{\circ}\text{C} \leq T_{\text{ambient}} \leq 25^{\circ}\text{C}$, the unit will operate in the previous state. If it is energized for the first time, it will operate in Fan mode.

d. When the unit operates in Auto mode, the compressor frequency during cooling operation is the same with that of heating mode.

② Protection

a. In cooling operation, protection is the same as that under the cooling mode;

b. In heating operation, protection is the same as that under the heating mode;

c. When ambient temperature changes, operation mode will be converted preferentially. Once started, the compressor will remain unchanged for at least 6 minutes.

(6) Common Protection Functions and Fault Display under COOL, HEAT, DRY and AUTO Modes

① Overload protection

T_{tube} : measured temperature of outdoor heat exchanger under cooling mode; and measured temperature of indoor heat exchanger under heating mode.

1) Cooling overload

a. If $T_{\text{tube}} \leq 52^{\circ}\text{C}$, the unit will return to its original operation state.

b. If $T_{\text{tube}} \geq 55^{\circ}\text{C}$, frequency rise is not allowed.

c. If $T_{\text{tube}} \geq 58^{\circ}\text{C}$, the compressor will run at reduced frequency.

d. If $T_{\text{tube}} \geq 62^{\circ}\text{C}$, the compressor will stop and the indoor fan will run at preset speed.

2) Heating overload

a. If $T_{\text{tube}} \leq 52^{\circ}\text{C}$, the unit will return to its original operation state.

b. If $T_{\text{tube}} \geq 55^{\circ}\text{C}$, frequency rise is not allowed.

c. If $T_{\text{tube}} \geq 58^{\circ}\text{C}$, the compressor will run at reduced frequency.

d. If $T_{\text{tube}} \geq 62^{\circ}\text{C}$, the compressor will stop and the indoor fan will blow residue heat and then stop.

② Exhaust temperature protection of compressor

If exhaust temperature $\geq 98^{\circ}\text{C}$, frequency is not allowed to rise.

If exhaust temperature $\geq 103^{\circ}\text{C}$, the compressor will run at reduced frequency.

If exhaust temperature $\geq 110^{\circ}\text{C}$, the compressor will stop.

If exhaust temperature $\leq 90^{\circ}\text{C}$ and the compressor has stayed at stop for at least 3 minutes, the compressor will resume its operation.

③ Communication fault

If the unit fails to receive correct signals for durative 3 minutes, communication fault can be justified and the whole system will stop.

④ Module protection

Under module protection mode, the compressor will stop. When the compressor remains at stop for at least 3 minutes, the compressor will resume its operation. If module protection occurs six times in succession, the compressor will not be started again.

⑤ Overload protection

If temperature sensed by the overload sensor is over 115°C , the compressor will stop and the outdoor fan will stop with a time lag of 30 seconds. If temperature is below 95°C , the overload protection will be relieved $^{\circ}\text{C}$.

If voltage on the DC bus is below 150V or over 420V, the compressor will stop and the outdoor fan will stop with a time lag of 30 seconds. When voltage on the DC bus returns to its normal value and the compressor has stayed at stop for at least 3 minutes, the compressor will resume its operation.

⑥ Faults of temperature sensors

Designation of sensors	Faults
Indoor ambient temperature	The sensor is detected to be open-circuited or short-circuited for successive 20 seconds
Indoor tube temperature	The sensor is detected to be open-circuited or short-circuited for successive 20 seconds
Outdoor ambient temperature	The sensor is detected to be open-circuited or short-circuited for successive 30 seconds
Outdoor tube temperature	The sensor is detected to be open-circuited or short-circuited for successive 30 seconds, and no detection is performed within 10 minutes after defrost begins.
Exhaust	After the compressor has operated for 3 minutes, the sensor is detected to be open-circuited or short-circuited for successive 30 seconds.
Overload	After the compressor has operated for 3 minutes, the sensor is detected to be open-circuited or short-circuited for successive 30 seconds.

3. Other Controls**(1) ON/OFF**

Press the remote button ON/OFF: the on-off state will be changed once each time you press the button.

(2) Mode Selection

Press the remote button MODE, then select and show in the following ways: AUTO, COOL, DRY, FAN, HEAT, AUTO.

(3) Temperature Setting Option Button

Each time you press the remote button TEMP+ or TEMP-, the setting temperature will be up or down by 1°C . Regulating Range: $16\sim 30^{\circ}\text{C}$, the button is useless under the AUTO mode.

(4) Time Switch

You should start and stop the machine according to the setting time by remote control.

(5) SLEEP State Control

a. When the air conditioner is under the mode of COOL, DRY, and the SLEEP mode has been set well, after the SLEEP state keeps about 1 hour, the pre-setting T will raise 1°C , and it will raise 1°C again after 2 hours, so it raise 2°C in 2 hours, then it will run on at the setting temperature and wind speed.

b. When the air conditioner is under the mode of HEAT, and the Timer has been set well, after the SLEEP state keeps about 1 hour, the pre-setting T will reduce 1°C , and it will reduce 1°C again after 2 hours, so it reduce 2°C in 2 hours, then it will run on at the setting temperature and wind speed.

c. The setting temperature keeps the same under the FAN mode and AUTO mode.

(6) Indoor Fan Control

The Indoor Fan can be set as HIGH, MED, LOW by remote control, and the Indoor Fan will be respectively run at high, medium, low speed. It will also be set as AUTO, and the Indoor Fan is as the followings at the automatic wind speed.

Cooling mode: $T_{\text{ring}} \geq T_{\text{setting}} + 2$, high speed; $T_{\text{setting}} - 2 < T_{\text{ring}} < T_{\text{setting}} + 2$, medium speed; $T_{\text{ring}} \leq T_{\text{setting}} - 2$, low speed.

Sending wind mode: : $T_{\text{ring}} > T_{\text{setting}} + 4$, high speed; $T_{\text{setting}} + 2 \leq T_{\text{ring}} \leq T_{\text{setting}} + 4$, medium speed; $T_{\text{ring}} < T_{\text{setting}} + 2$, low speed.

Moisture removal mode: force to be set as the low speed

Heating mode: $T_{\text{ring}} \leq T_{\text{setting}} + 1$ high speed; $T_{\text{setting}} + 1 < T_{\text{ring}} < T_{\text{setting}} + 5$, medium speed; $T_{\text{ring}} \geq T_{\text{setting}} + 2$, low speed.

(7) Buzzer Control

The buzzer will send a "Di" sound when the air conditioner is powered up or received the information sent by the remote control or there is a button input, the single tube cooler doesn't receive the remote control ON signal under the mode of heating mode.

(8) Auto button

If the controller is on, it will stop by pressing the button, and if the controller is off, it will be automatic running state by pressing the button, swing on and light on, and the main unit will run based on the remote control if there is remote control order.

(9) Up-and-Down Swinging Control

① After energization, the upper horizontal louver will firstly open to a certain degree and then the up & down horizontal louver will rotate to P0 to close the air outlet.

② Swing function has not been set after startup of the unit

Start up the unit, after finishing swinging and rotating to P0, the horizontal louver will firstly open to a certain degree and then the up & down horizontal louver will rotate at the same time. In other modes except heating mode, the up & down horizontal louver will rotate to P7. In heating mode, the up & down horizontal louver will rotate to P4.

③ Swing function is set when starting up the unit

In other modes except heating mode, the set degrees of swinging are: P7-P6-P5-P4-P3. In heating mode, the set degrees of swinging are: P2-P3-P4-P5-P6.

④ Auto swing

When receive the order of auto swing from the remote controller, under other modes except heating mode, the up & down horizontal louver will rotate from P7 to P3; under heating mode, the up & down horizontal louver will rotate from P2 to P6. If auto swing is cancelled, the horizontal louver will stop at the present position.

⑤ Anti-moisture protection (available in cooling, auto cooling and dry modes)

When the indoor fan runs in quiet speed, the rotation range of the upper horizontal louver is from P6-P4.

⑥ Anti-noise function

The indoor fan, the compressor and the outdoor fan are able to be energized when the horizontal louver rotates to P2.

⑦ Swing function after turning off the unit

After turning off the unit, the horizontal louver will close at P0.

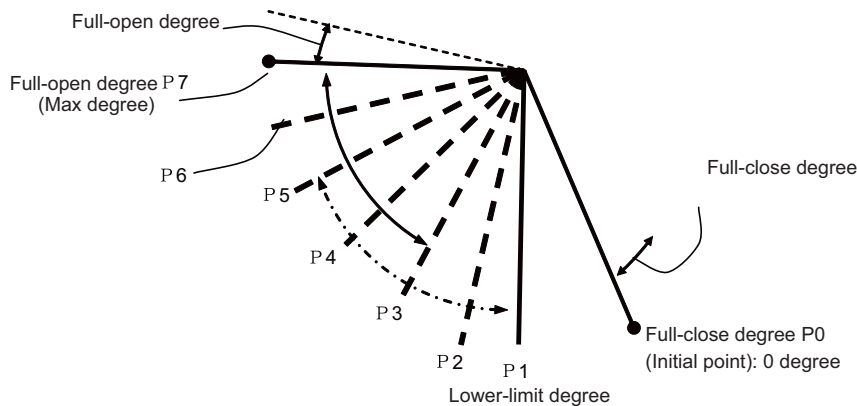

(10) Display

① Operation pattern and mode pattern display

All the display patterns will display for a time when the power on, the operation indication pattern will display in red under standby status. When the machine is start by remote control, the indication pattern will light and display the current operation mode (the mode light includes: Cooling, heating and dehumidify). If you close the light key, all the display patterns will close.

② Double-8 display

According to the different setting of remote control, the nixie light may display the current temperature (the temperature scope is from 16℃ to 30℃) and indoor ambient temperature. The heating and air supply temperature will display 25℃ under auto-mode, the temperature will display 18℃ under the heating mode, and the temperature will display H1 under the defrosting mode.(If you set the fahrenheit temperature display, the nixie light will display according to fahrenheit temperature)

(11) Protection function and failure display

E2: Freeze-proofing protection E4: Exhausting protection E5: Overcurrent protection

E6: Communication failure E8: Overload protection

F1: Indoor ambient sensor start and short circuit (continuously measured failure in 30S)

F2: Indoor evaporator sensor start and short circuit (continuously measured failure in 30S)

F3: Outdoor ambient sensor start and short circuit (continuously measured failure in 30S)

F4: Outdoor condenser sensor start and short circuit (continuously measured failure in 30S, and dont measure within 10 minutes after defrosted)

F5: Outdoor exhausting sensor start and short circuit (continuously measured failure in 30S after the compressor operated 3 minutes)

H3: Overload protection of compressor H5: Module protection

PH: High-voltage protection PL: Low-voltage protection

P1: Nominal cooling and heating P2: Maximum cooling and heating

P3: Medium cooling and heating P0: Minimum cooling and heating

(12) Memory function when interrupting the power supply

Memory content: mode, swing function, light, set temperature and wind speed. After interrupted the power supply, the machine will start when recovering the power according to the memory content automatically. If the last remote control command has not set the timed function, the system will remember the last remote control command and operate according it. If the last remote control command has set timed function and the power supply is interrupted before the timed time, the system will remember the timed function of the last remote control command, the timed time will recounted form power on. If the last remote control command has set timed function, the time is out and the system is start or stop according to the set time when the power supply is interrupted, the system will remember the operation status before the power supply was interrupted, and do not carry out timed action; The timed clock will not remembered.

(13)Quiet Mode

- ① Auto quiet: If auto quiet fan speed is selected, the fan speed will be adjusted according to the change of ambient temperature. When the temperature meets the setting requirement, it will run at low speed.
- ② Quiet mode: If quiet fan speed is selected, it will run at low speed directly.

(14)Energy-saving Mode

If energy-saving mode is set, the set temperature will be adjusted automatically in order to achieve the purposes of comfort and energy saving.

(15)Fan speed automatically adjust function in heating mode

In heating mode, when the indoor tube temperature is relatively low, the fan speed will turn low automatically to ensure comfortableness.

7. Installation Manual

7.1 Notices for Installation

Caution

- 1.The unit should be installed only by authorized service center according to local or government regulations and in compliance with this manual.
- 2.Before installing, please contact with local authorized maintenance center. If the unit is not installed by the authorized service center, the malfunction may not be solved due to inconvenient contact between the user and the service personnel.
- 3.When removing the unit to the other place, please firstly contact with the local authorized service center.
- 4.Warning: Before obtaining access to terminals, all supply circuits must be disconnected.
- 5.For appliances with type Y attachment, the instructions shall contain the substance of the following. If the supply cord is damaged, it must be replaced by the manufacturer, its service agent or similarly qualified persons in order to avoid a hazard.
- 6.The appliance must be positioned so that the plug is accessible.

7.The temperature of refrigerant line will be high; please keep the interconnection cable away from the copper tube.

8.The instructions shall state the substance of the following:

This appliance is not intended for use by persons(including children)with reduced physical, sensory or mental capabilities, or lack of experience and knowledge, unless they have been given supervision or instruction concerning use of the appliance by a person responsible for their safety.

Children should be supervised to ensure that they do not play with the appliance.

7.1.1 Installation Site Instructions

Proper installation site is vital for correct and efficient operation of the unit. Avoid the following sites where:

- strong heat sources, vapours, flammable gas or volatile liquids are emitted.
- high-frequency electro-magnetic waves are generated by radio equipment, welders and medical equipment.
- salt-laden air prevails (such as close to coastal areas).
- the air is contaminated with industrial vapours and oils.
- the air contains sulphures gas such as in hot spring zones.
- corrosion or poor air quality exists.

7.1.2 Installation Site of Indoor Unit

- 1.The air inlet and outlet should be away from the obstructions. Ensure the air can be blown through the whole room.
- 2.Select a site where the condensate can be easily drained out, and where it is easily connected to outdoor unit.
- 3.Select a place where it is out of reach of children.
- 4.Select a place where the wall is strong enough to withstand the full weight and vibration of the unit.
- 5.Be sure to leave enough space to allow access for routine maintenance. The installation site should be 250cm or more above the floor.
- 6.Select a place about 1m or more away from TV set or any other electric appliance.
- 7.Select a place where the filter can be easily taken out.
- 8.Make sure that the indoor unit is installed in accordance with installation dimension instructions.
- 9.Do not use the unit in the laundry or by swimming pool etc.

7.1.3 Installation Site of Outdoor Unit

- 1.Select a site where noise and outflow air emitted by the unit will not annoy neighbors.
- 2.S elect a site where there is sufficient ventilation.
- 3.Select a site where there is no obstruction blocking the inlet and outlet.
- 4.The site should be able to withstand the full weight and vibration.
- 5.Select a dry place, but do not expose the unit to direct sunlight or strong wind.
- 6.Make sure that the outdoor unit is installed in accordance with the installation instructions,and is convenient for maintenance and repair.
- 7.The height difference between indoor and outdoor units is within 10 m, and the length of the connecting tubing does not exceed 25m.
- 8.Select a place where it is out of reach of children.
- 9.Select a place where the unit does not have negative impact on pedestrians or on the city.

7.1.4 Safety Precautions for Electric Appliances

1. A dedicated power supply circuit should be used in accordance with local electrical safety regulations.
2. Don't drag the power cord with excessive force.
3. The unit should be reliably earthed and connected to an exclusive earth device by the professionals.
4. The air switch must have the functions of magnetic tripping and heat tripping to prevent short circuit and overload.
5. The minimum distance between the unit and combustive surface is 1.5m.
6. The appliance shall be installed in accordance with national wiring regulations.
7. An all-pole disconnection switch with a contact separation of at least 3mm in all poles should be connected in fixed wiring.

Note:

- **Make sure the live wire, neutral wire and earth wire in the family power socket are properly connected. There should be reliable circuit in the diagram.**
- **Inadequate or incorrect electrical connections may cause electric shock or fire.**

7.1.5 Earthing Requirements

1. Air conditioner is type I electric appliance. Please ensure that the unit is reliably earthed.
2. The yellow-green wire in air conditioner is the earthing wire which can not be used for other purposes. Improper earthing may cause electric shock.
3. The earth resistance should accord to the national criterion.
4. The power must have reliable earthing terminal. Please do not connect the earthing wire with the following:
 - ① Water pipe
 - ② Gas pipe
 - ③ Contamination pipe
 - ④ Other place that professional personnel consider is unreliable
5. The model and rated values of fuses should accord with the silk print on fuse cover or related PCB.

7.2 Installation Drawing

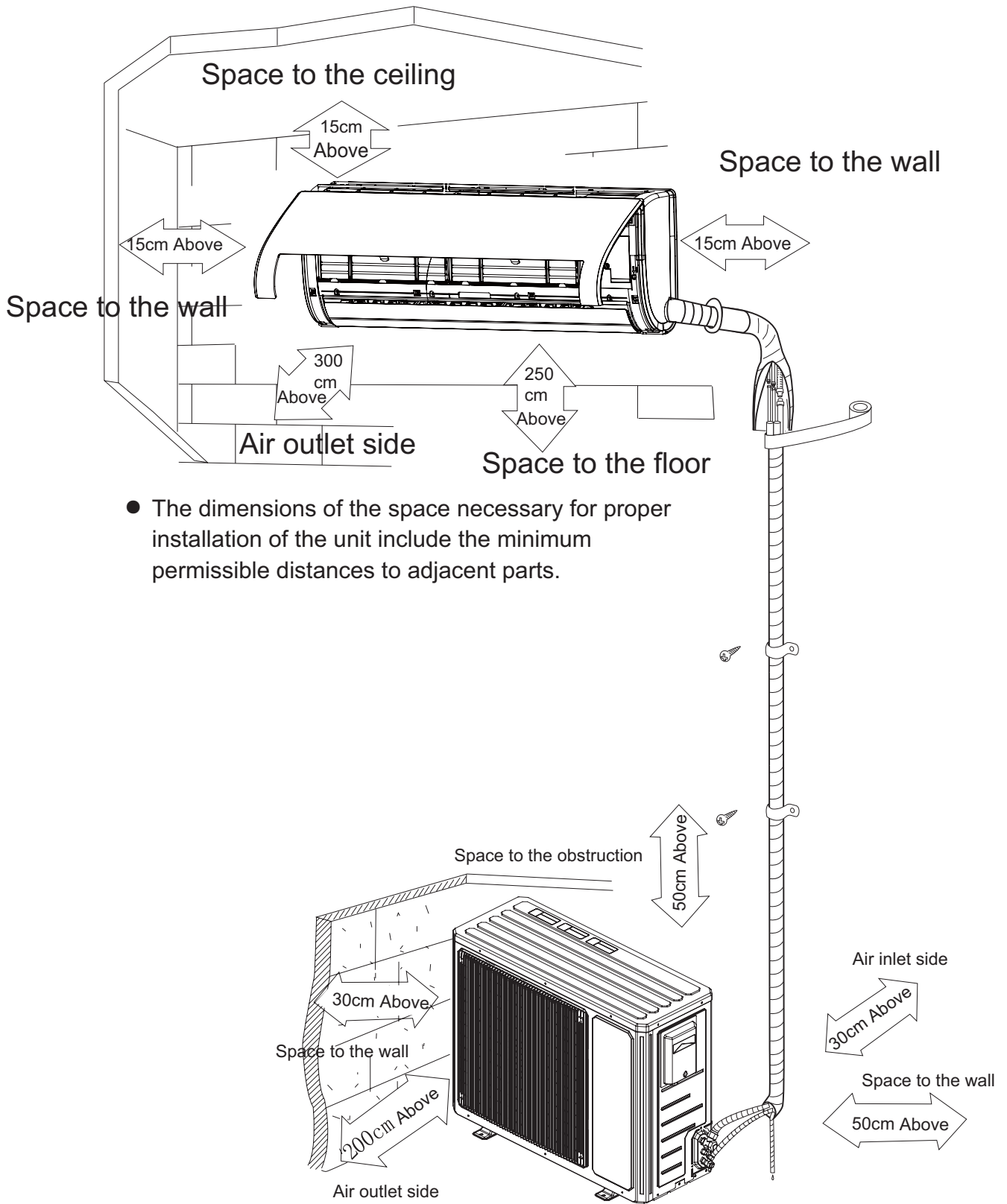

7.3 Install Indoor Unit

7.3.1 Installation of Mounting Plate

1. Mounting plate should be installed horizontally. As the water tray's outlet for the indoor unit is two-way type, during installation, the indoor unit should slightly slant to water tray's outlet for smooth drainage of condensate.
2. Fix the mounting plate on the wall with screws.
3. Be sure that the mounting plate has been fixed firmly enough to withstand about 60 kg. Meanwhile, the weight should be evenly shared by each screw.

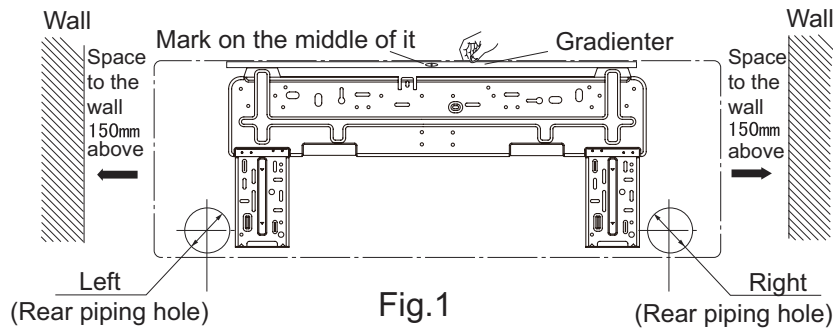

7.3.2 Drill Piping Hole

1. Slant the piping hole ($\Phi 55$) on the wall slightly downward to the outdoor side.
2. Insert the piping-hole sleeve into the hole to prevent the connection piping and wiring from being damaged when passing through the hole.

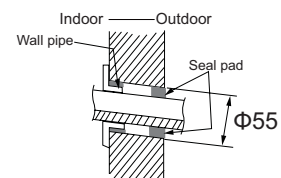

7.3.3 Installation of Drain Hose

1. Connect the drain hose to the outlet pipe of the indoor unit. Bind the joint with rubber belt.
2. Put the drain hose into insulating tube.

3. Wrap the insulating tube with wide rubber belt to prevent the shift of insulating tube. Slant the drain hose downward slightly for smooth drainage of condensate.

Note: The insulating tube should be connected reliably with the sleeve outside the outlet pipe. The drain hose should be slanted downward slightly, without distortion, bulge or fluctuation. Do not put the outlet in the water.

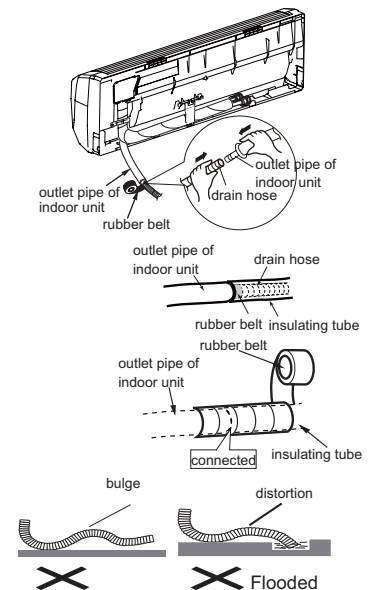

7.3.4 Connecting Indoor and Outdoor Electric Wires

1. Open the front panel.
2. Remove the wiring cover. Connect and fix the power connection cord to the terminal board, as shown in Fig 2.
3. Make the power connection cord pass through the hole at the back of indoor unit.
4. Reinstall the cord anchorage and wiring cover.
5. Reinstall the front panel.

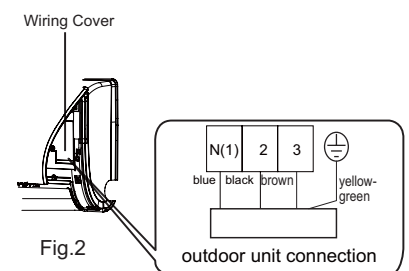

NOTE:

All wires between indoor and outdoor units must be connected by the qualified electric contractor.

- Electric wires must be connected correctly. Improper connection may cause malfunction.
- Tighten the terminal screws securely.
- After tightening the screws, pull the wire slightly to confirm whether it's firm or not.
- Make sure that the electric connections are earthed properly to prevent electric shock.
- Make sure that all wiring connections are secure and the cover plates are reinstalled properly. Poor installation may cause fire or electric shock.

7.3.5 Installation of Indoor Unit

- The piping can be output from right, right rear, left or left rear.
1. When routing the piping and wiring from the left or right side of indoor unit, cut off the tailings from the chassis when necessary (As shown in Fig.3)
 - (1) Cut off tailing 1 when routing the wiring only;
 - (2) Cut off tailing 1 and tailing 2 when routing both the wiring and piping.
 2. Take out the piping from body case; wrap the piping, power cords, drain hose with the tape and then make them pass through the piping hole. (As shown in Fig.4)
 3. Hang the mounting slots of the indoor unit on the upper hooks of the mounting plate and check if it is firm enough. (As shown in Fig.5)
 4. The installation site should be 250cm or more above the floor.

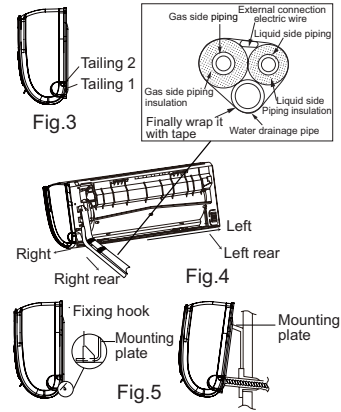

7.3.6 Installation of Connection Pipe

1. Align the center of the pipe flare with the related valve.
2. Screw in the flare nut by hand and then tighten the nut with spanner and torque wrench by referring to the following:

Tube diameter	Tightening torque, approximate(N·m)
Φ6.35(1/4")	14~18N·m(140-180kgf.cm)
Φ9.52(3/8")	34~42N·m(340-420kgf.cm)
Φ12.7(1/2")	49~61N·m(490-610kgf.cm)
Φ15.88(5/8")	68~82N·m(680-820kgf.cm)

NOTE: Connect the connection pipe to indoor unit at first and then to outdoor unit. Handle piping bending with care. Do not damage the connection pipe. Ensure that the joint nut is tightened firmly, otherwise, it may cause leakage.

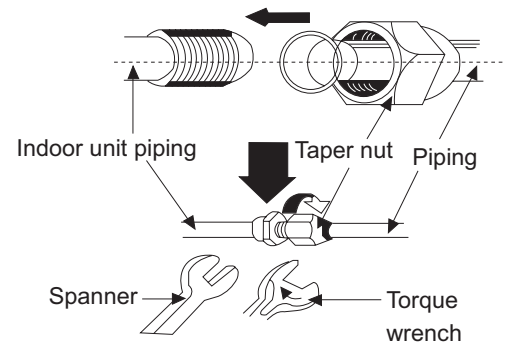

7.3.7 Notice for the disassembly of air connecting wire

• The notice for the disassembly of air connecting wire are only applicable for the unit with air function

1. Air power cord passes through the heat-shrinkable bushing at first, and then connect with the air connecting wire of indoor fan.
2. Set inside the butt terminal with heat-shrinkable, and then bundle a tieline at both sides.
3. Use type R wire clip fix the air connecting wire at this screw pole. The air connecting wire can't be mixed with the rubber insulated wire and power cord. Meanwhile, place the wire with bushing at this cavity to prevent it pressing during disassembly.

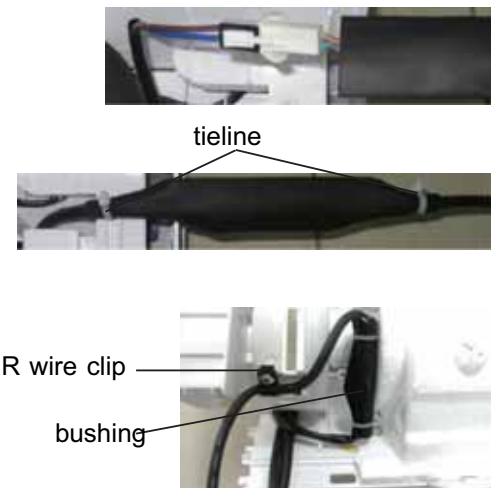

7.4 Install Outdoor Unit

7.4.1 Electric Wiring

- 1.Remove the handle on the outdoor unit right side plate.
- 2.Take off wire cord anchorage. Connect and fix the power connection cord to the terminal board. Wiring should fit that of indoor unit.
- 3.Fix the power connection cord with wire clamps and then connect the corresponding connector.
- 4.Confirm if the wire has been fixed properly.
- 5.Reinstall the handle.

NOTE:

- Incorrect wiring may cause malfunction of spare part.
 - After the wire has been fixed, ensure there is free space between the connection and fixing places on the lead wire.
- Schematic diagram being reference only, please refer to real product for authentic information.

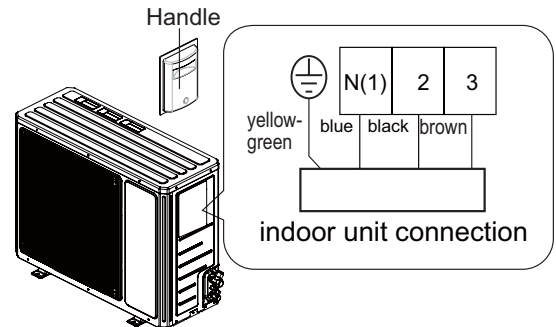

7.4.2 Air Purging and Leakage Test

- 1.Connect charging hose of manifold valve to charge end of low pressure valve (both high/low pressure valves must be tightly shut). Connect joint of charging hose to vacuum pump.
3. Fully open the handle of Lo manifold valve.
4. Open the vacuum pump for vacuumization. At the beginning, slightly loosen joint nut of low pressure valve to check if there is air coming inside (If noise of vacuum pump has been changed, the reading of multimeter is 0). Then tighten the nut.
- 5.Keep vacuuming for more than 15mins and make sure the reading of multi-meter is -1.0×10^5 pa(-76cmHg).
6. Fully open high/low pressure valves.
7. Remove charging hose from charging end of low pressure valve.
8. Tighten lid of low pressure valve. (As shown in Fig.6)

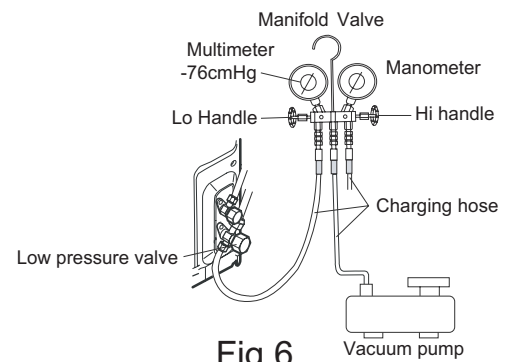
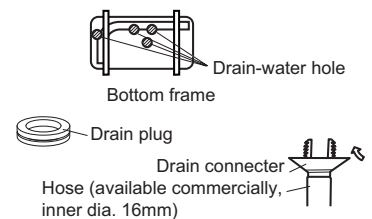

Fig.6

7.4.3 Outdoor Condensate Drainage (only for Heat pump unit)

During heating operation, the condensate and defrosting water should be drained out reliably through the drain hose. Install the outdoor drain connector in a $\Phi 25$ hole on the base plate and attach the drain hose to the connector so that the waste water formed in the outdoor unit can be drained out .The hole diameter 25 must be plugged.

Whether to plug other holes will be determined by the dealers according to actual conditions.



7.5 Check after Installation and Operation Test

7.5.1 Check after Installation

Items to be checked	Possible malfunction
Has it been fixed firmly?	The unit may drop, shake or emit noise.
Have you done the refrigerant leakage test?	It may cause insufficient cooling(heating)capacity
Is heat insulation sufficient?	It may cause condensation and dripping.
Is water drainage satisfactory?	It may cause condensation and dripping.
Is the voltage in accordance with the rated voltage marked on the nameplate?	It may cause electric malfunctionor damage the product.
Is the electric wiring and piping connection installed correctly and securely?	It may cause electric malfunction or damage the part.
Has the unit been connected to a secure earth connection?	It may cause electrical leakage.
Is the power cord specified?	It may cause electric malfunctionor damage the part.
Are the inlet and outlet openings blocked?	It may cause insufficient cooling(heating) capacity.
Is the length of connection pipes and refrigerant capacity been recorded?	The refrigerant capacity is not accurate.

7.5.2 Operation Test

1. Before Operation Test

- (1) Do not switch on power before installation is finished completely.
- (2) Electric wiring must be connected correctly and securely.
- (3) Cut-off valves of the connection pipes should be opened.
- (4) All the impurities such as scraps and thums must be cleared from the unit.

2. Operation Test Method

- (1) Switch on power and press "ON/OFF" button on the remote controller to start operation.
- (2) Press MODE button to select the COOL, HEAT (Not available for cooling only unit), FAN to check whether the operation is normal or not.

7.6 Installation and Maintenance of Healthy Filter

7.6.1 Installation of Healthy Filter

1. Press the clasp as shown by arrow (1) to loosen the clasps at the lower end until a sound of "crack" is heard; press the clasp as shown by arrow (2) to open the clasps at the upper end; open the panel and then pull the filter downward to remove it. (As shown in fig a)

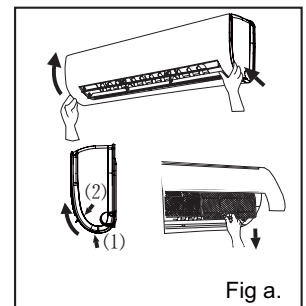

Fig a.

2. Install the healthy filter on the air filter (as shown in fig b). If the healthy filter fails to be installed on the air filter, please install the healthy filter on the front case (As shown in fig c).

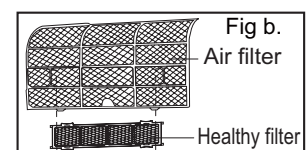
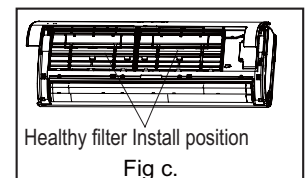

Fig b.



Healthy filter Install position
Fig c.

3.3. Install the air filter along arrow (1) direction and then buckle the panel cover along arrow (2). (As shown in fig d).

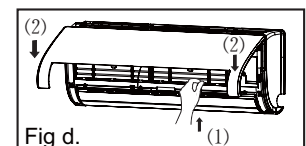

Fig d.

7.6.2 Cleaning and Maintenance

Remove the healthy filter and reinstall it after cleaning according to the installation instruction. Don't use brush or hard things to clean the filter. After cleaning, be sure to dry it in the shade.

7.6.3 Service Life

The general service life for the healthy filter is about one year under normal condition. As for silver ion filter, it is invalid when its surface becomes black (green).

● This supplementary instruction is provided for reference to the unit with healthy filter. If the graphics provided herein is different from the actual product, please refer to the actual product. The quantity of healthy filters is based on the actual delivery.

8. Exploded Views and Parts List

8.1 Indoor Unit

GWH18UC-K3DNA1A/I

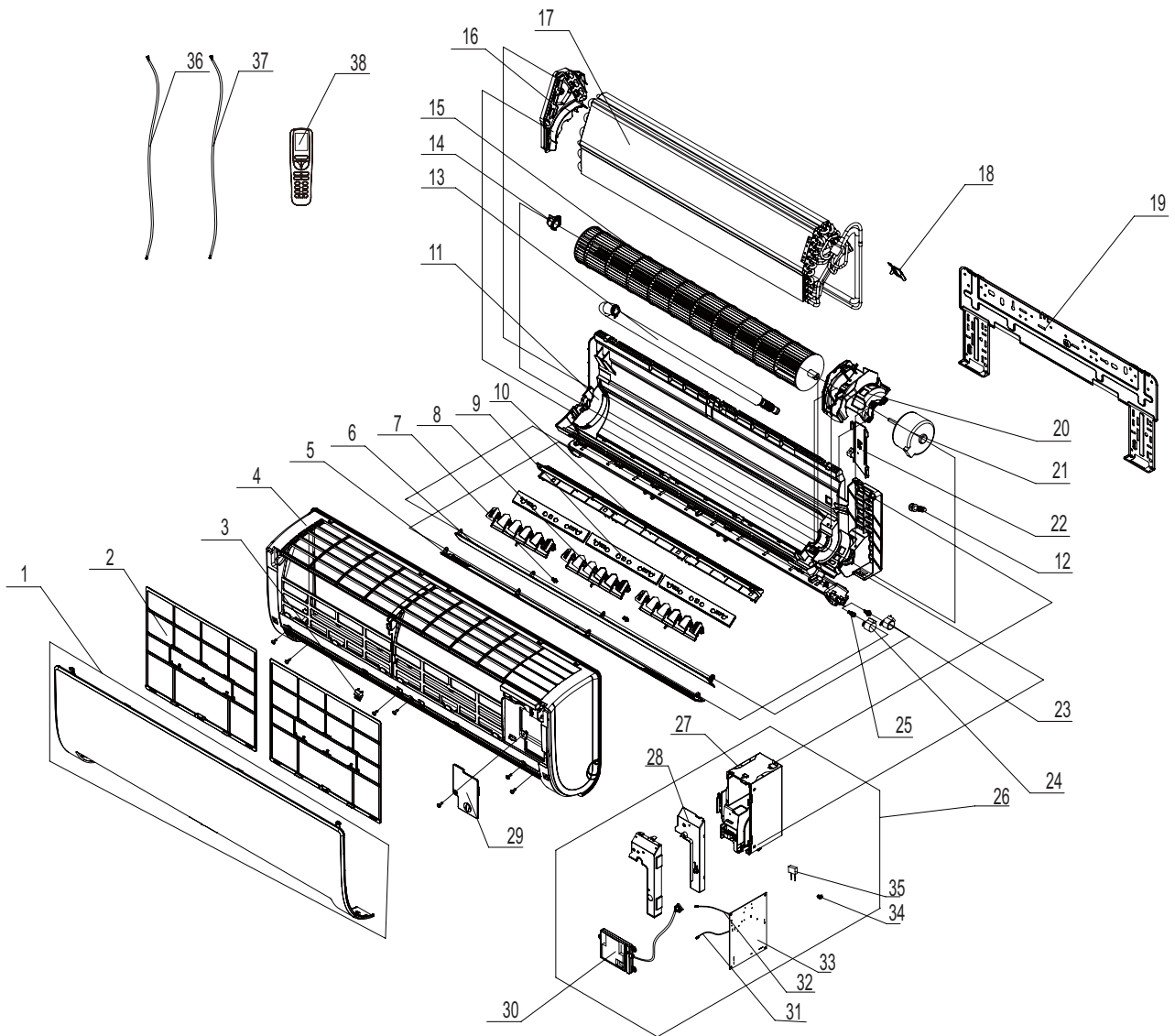

Exploded Views and Parts list

NO.	Description	Part Code		Qty
		GWH18UC-K3DNA1A/I		
		CB204N00600		
1	Front Panel Assy	2001280401		1
2	Filter Sub-Assy	11122133		2
3	Screw Cover	24252024		3
4	Front Case Sub-assy	20012805		1
5	Guide Louver 2	10512223		1
6	Guide Louver 1	10512222		1
7	Shaft of Guide Louver	1054202001		6
8	Air Louver(Manual)	10512221		3
9	Louver Clamp	26112493		3
10	Helicoid Tongue	26112495		1
11	Rear Case assy	22202472		1
12	Rubber Plug (Water Tray)	76712012		1
13	Drainage Hose	0523001406		1
14	Axile Bush Sub-assy	10542024		1
15	Cross Flow Fan	10352030		1
16	Evaporator Support	24212135		1
17	Evaporator Assy	01002327		1
18	Shield Board (Elbow)	01382010		1
19	Wall Mounting Frame	01252004		1
20	Motor Press Plate	26112295		1
21	Fan Motor	1501209802		1
22	Pipe Clamp	26112164		1
23	Step Motor	15212125		1
24	Step Motor	15212126		1
25	Crank	73012005		2
26	Electric Box Assy	20202963		1
27	Electric Box	20112134		1
28	Electric Box Cover	20122158		1
29	Electric Box Cover2	20122159		1
30	Display Board	30565134		1
31	Temperature Sensor	390000455		1
32	Temperature Sensor	390000592G		1
33	Main Board	30138901		1
34	Jumper	4202300111		1
35	Capacitor CBB61	33010034		1
36	Connecting Cable	40020553		0
37	Power Cord	400204877		1
38	Remote Controller	30510134		1

The data above are subject to change without notice.

GWH18UC-K3DNA2A/I

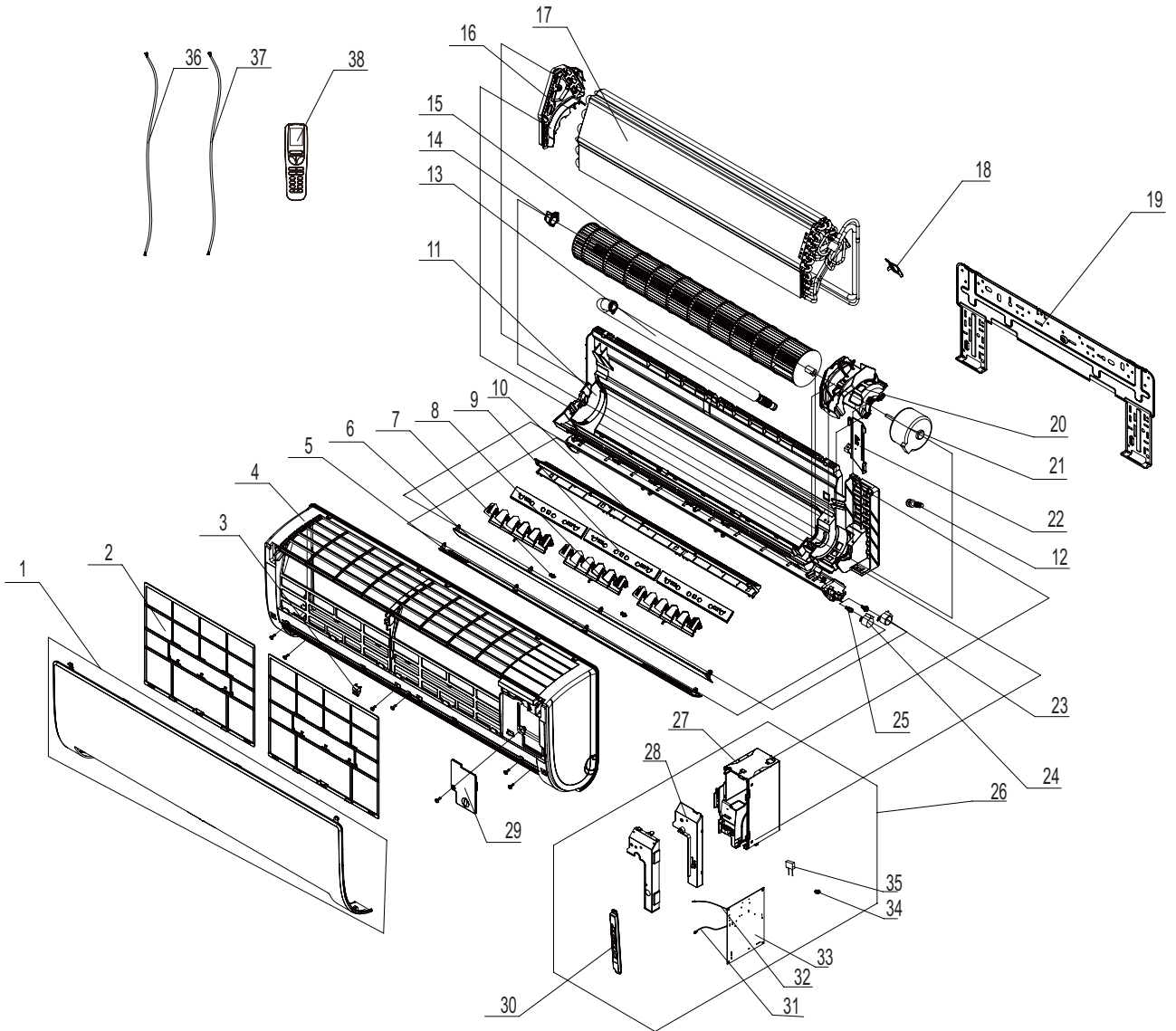

Exploded Views and Parts list

NO.	Description	Part Code		Qty
		GWH18UC-K3DNA2A/I		
		Product Code		
		CB221N00600		
1	Front Panel Assy	2001286702		1
2	Filter Sub-Assy	1112213302		2
3	Screw Cover	2425202401P		3
4	Front Case Sub-assy	2001280502		1
5	Guide Louver 2	1051222302P		1
6	Guide Louver 1	1051222202P		1
7	Shaft of Guide Louver	10542020		6
8	Air Louver(Manual)	1051222101		3
9	Louver Clamp	2611249301		3
10	Helicoid Tongue	2611249501		1
11	Rear Case assy	2220247201		1
12	Rubber Plug (Water Tray)	76712012		1
13	Drainage Hose	0523001406		1
14	Axile Bush Sub-assy	10542024		1
15	Cross Flow Fan	10352030		1
16	Evaporator Support	24212135		1
17	Evaporator Assy	01002327		1
18	Shield Board (Elbow)	01382010		1
19	Wall Mounting Frame	01252004		1
20	Motor Press Plate	26112295		1
21	Fan Motor	1501209802		1
22	Pipe Clamp	26112164		1
23	Step Motor	15212125		1
24	Step Motor	15212126		1
25	Crank	73012005		2
26	Electric Box Assy	20302093		1
27	Electric Box	20112134		1
28	Electric Box Cover	20122158		1
29	Electric Box Cover2	2012215902P		1
30	Display Board	30565153		1
31	Temperature Sensor	390000455		1
32	Temperature Sensor	390000592G		1
33	Main Board	30138901		1
34	Jumper	4202300111		1
35	Capacitor CBB61	33010034		1
36	Connecting Cable	40020553		0
37	Power Cord	400204877		1
38	Remote Controller	30510134		1

The data above are subject to change without notice.

8.2 Outdoor Unit

GWH18UC-K3DNA1A/O

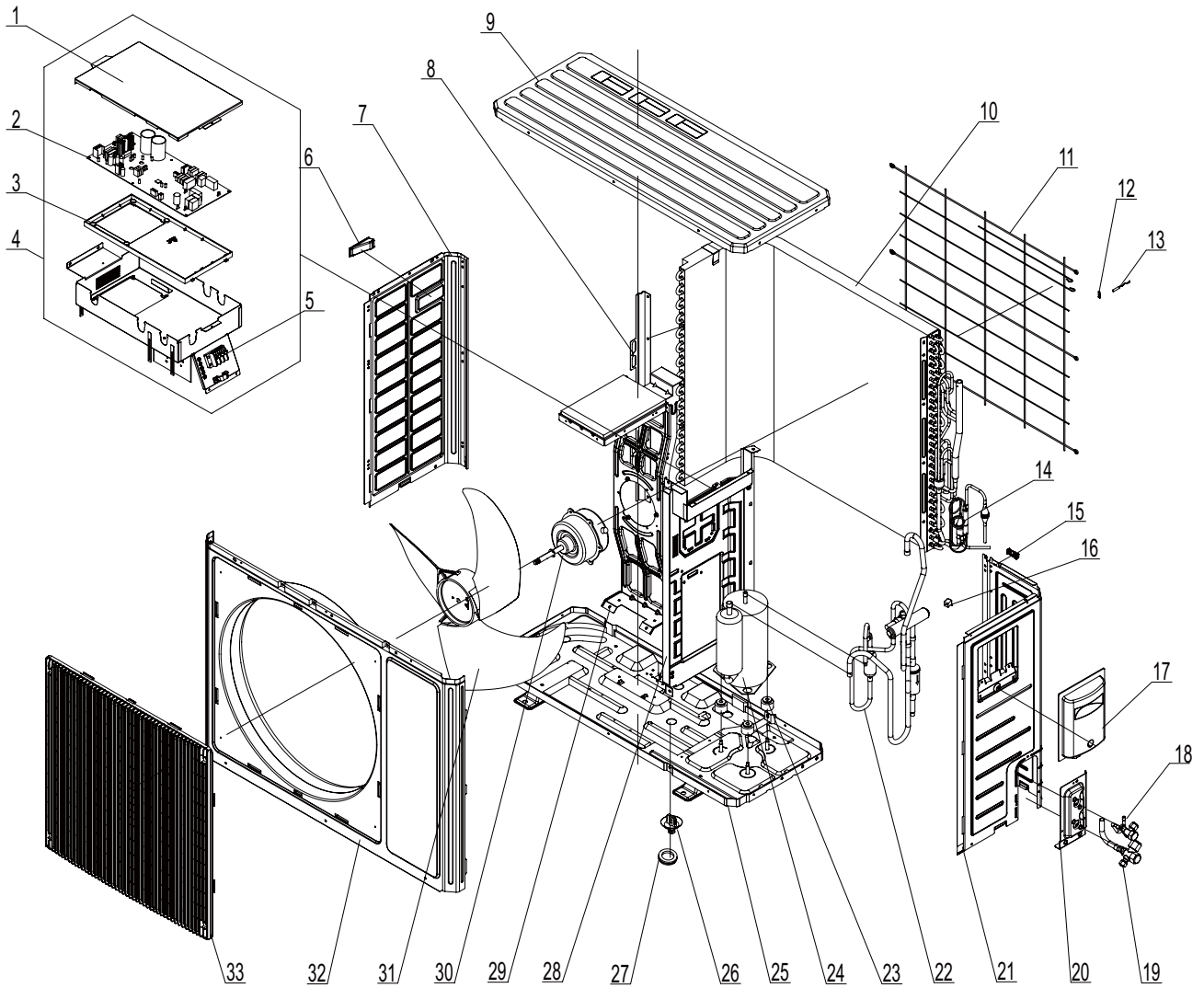

Exploded Views and Parts list

NO.	Description	Part Code	Qty
		GWH18UC-K3DNA1A/O	
		Product Code	
		CB204W00600	
1	Electric Box Cover	01413171	1
2	Main Board	30138957	1
3	Electric Box 1	20113005	1
4	Electric Box Assy	0260360901	1
5	Terminal Board	42011113	1
6	Left Handle	26235401	1
7	Left Side Plate	01305041P	1
8	Supporting	01795021	1
9	Top Cover	01255005P	1
10	Condenser Assy	01163132	1
11	Rear Grill	01473043	1
12	Sensor Insert	42020063	1
13	Temperature Sensor	3900030902G	1
14	Capillary Sub-assy	03063607	1
15	Wiring clamp	26115004	1
16	Magnet Coil	4300040047	1
17	Handle	26235254	1
18	Cut off Valve Sub-Assy	07133472	1
19	Cut off Valve Sub-Assy	07133060	1
20	Valve support assy	01715010P	1
21	Right Side Plate	01305053P	1
22	4-Way Valve Assy	03123700	1
23	Rubber Grommet	76815215	3
24	Compressor and fittings	00205262	1
25	Chassis Sub-assy	01203884P	1
26	Drainage Connector	06123401	1
27	Drainage Plug	06813401	3
28	Clapboard Sub-Assy	01232902	1
29	Motor Support Sub-Assy	01705259	1
30	Fan Motor	15013309	1
31	Axial Flow Fan	10335012	1
32	Front Panel	01535008P	1
33	Front Grill	22415002	1

The data above are subject to change without notice.

9. Troubleshooting

9.1 Malfunction Analysis

Note: When replacing the controller, be sure to insert the wire jumper into the new controller, otherwise the unit will display C5

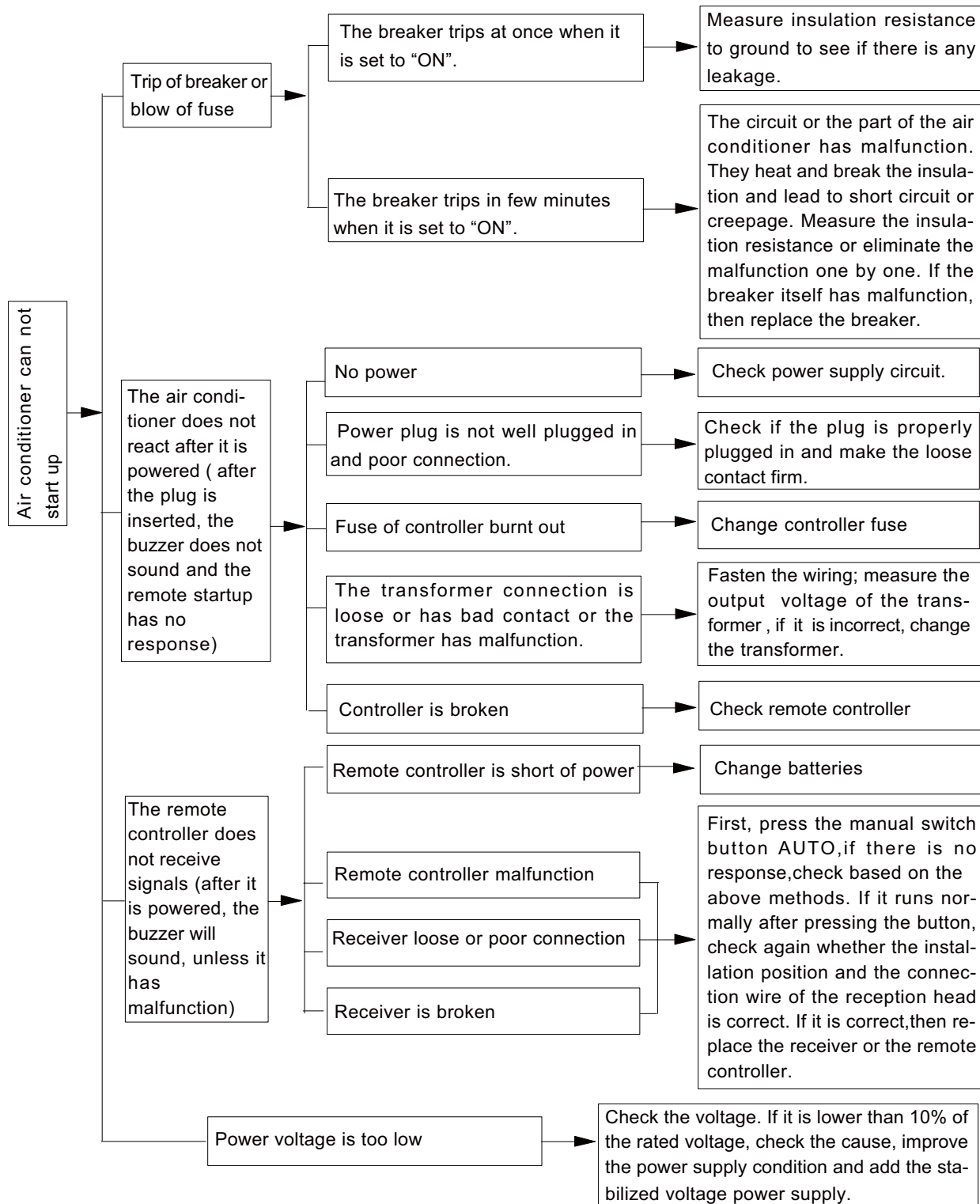

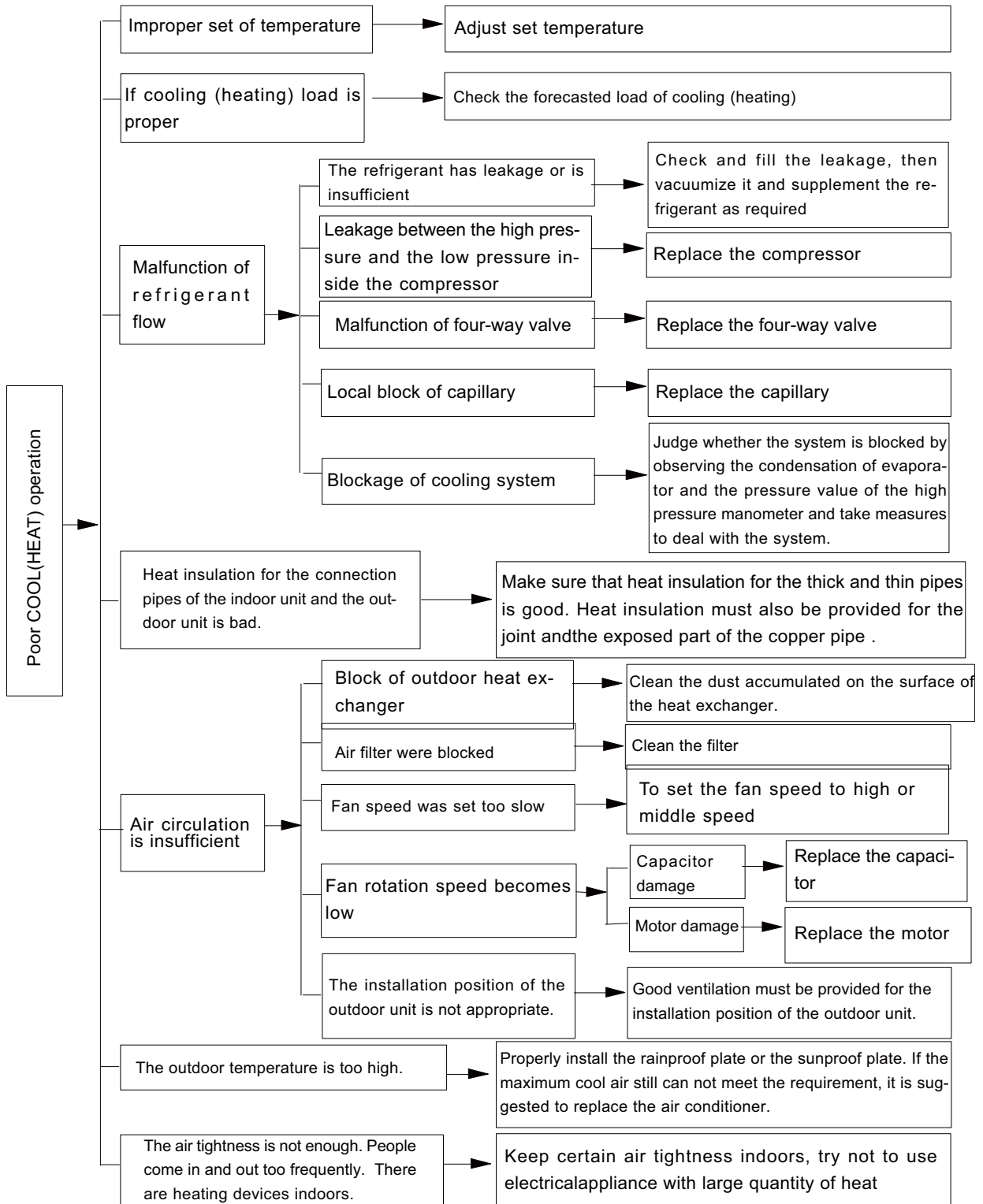

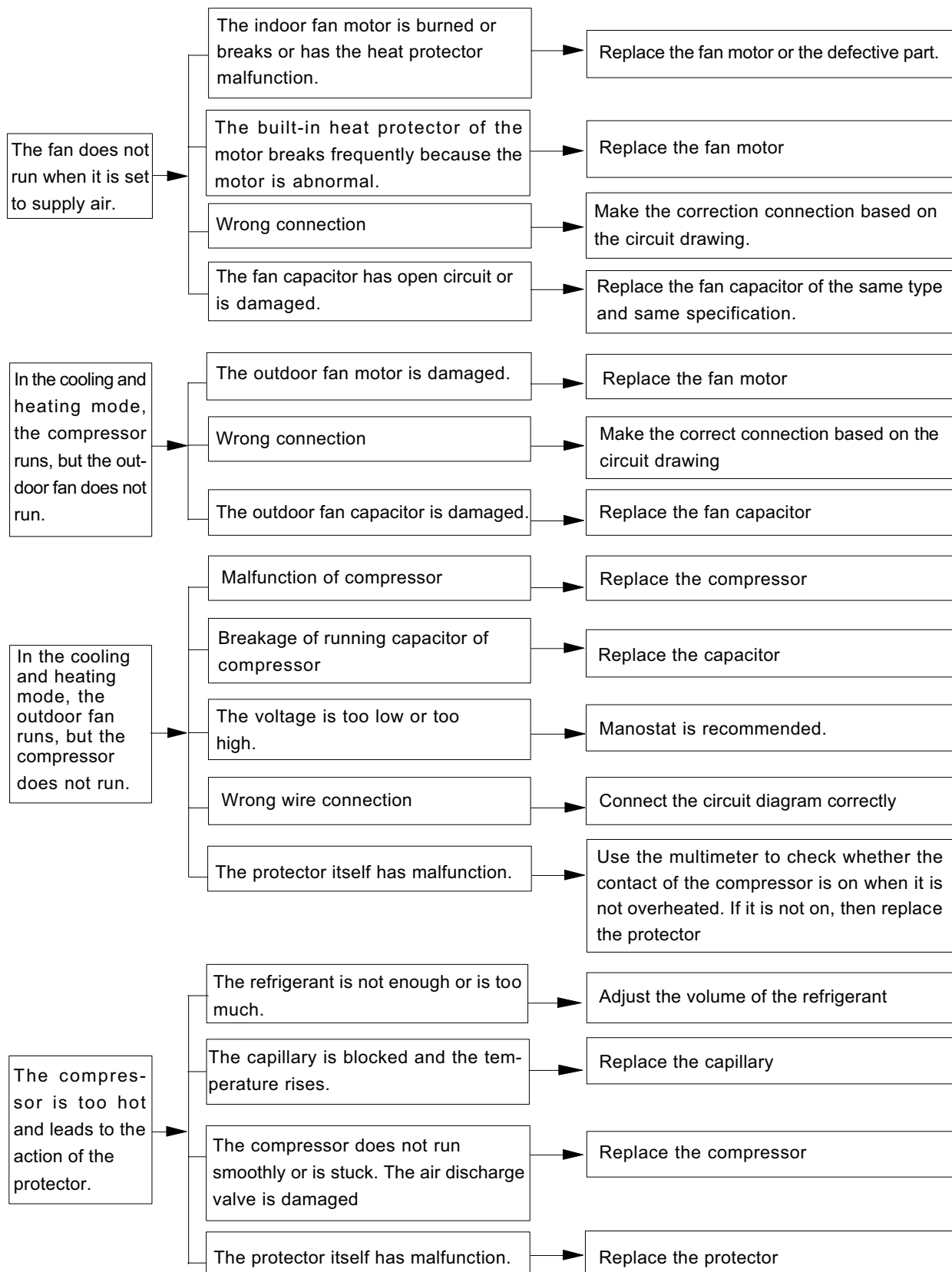

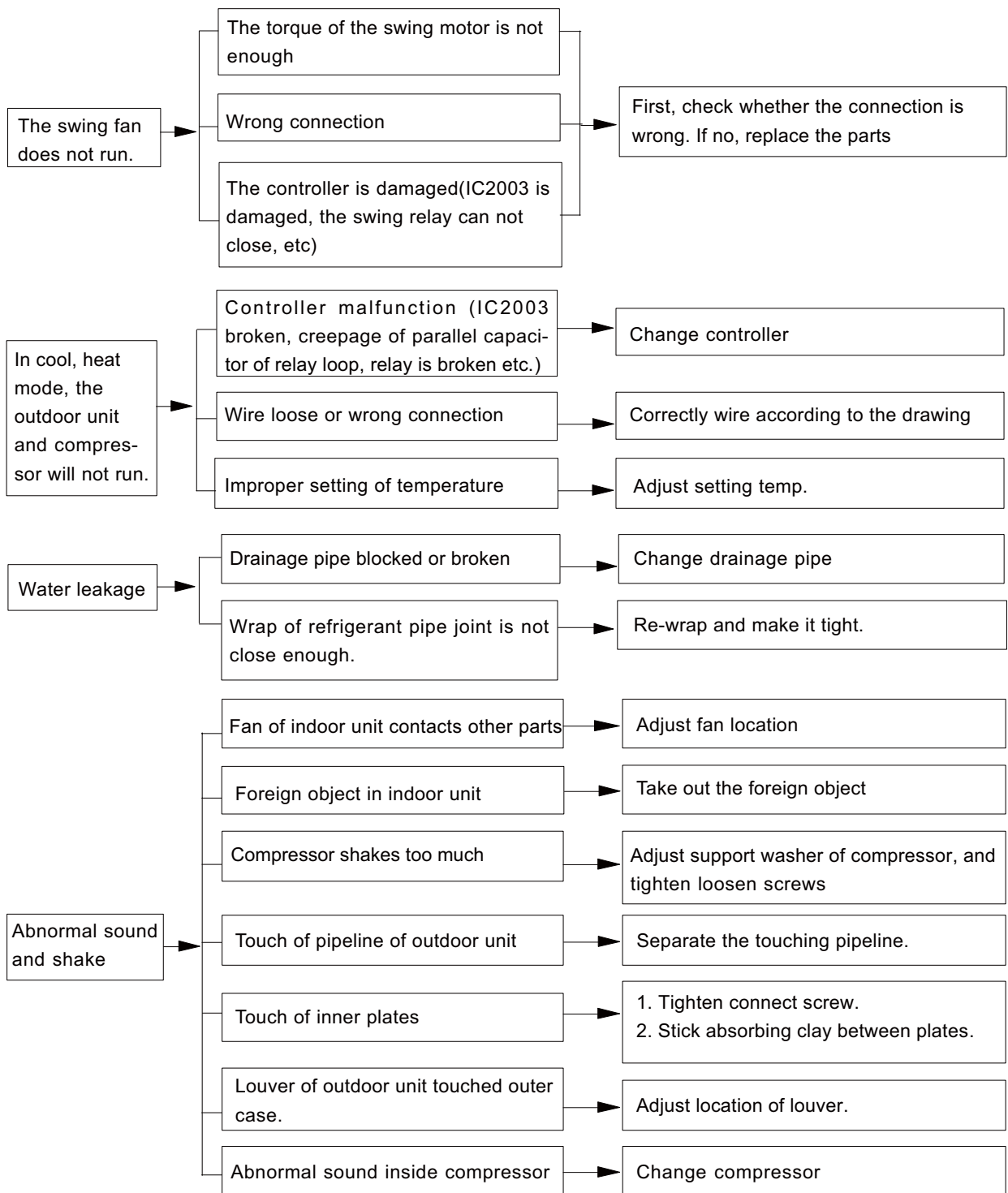

9.2 Flashing LED of Indoor/Outdoor Unit and Primary Judgement

Name of malfunction	Display of indoor unit	state of the lamps of outdoor unit PCB			Reasons
	ERROR CODE	GREEN-LED2	RED-LED3	YELLOW-LED4	
Stop for anti-freezing protection of indoor-unit	E2		blink-4 times	blink-3times	refrigerant leakage、 indoor unit air flow blocked up、 filter duty
Stop for exhaust protection	E4			blink-7 times	less refrigerant、 capillary blocked up、 ambient temperature is abominable
Stop for low voltage protection	E5			blink-5 times	low、 voltage、 ambient temperature is abominable
Stop for communication malfunction	E6	do not blink			communication line failure、 main PCB failure、 interfere souce、 connect line wrong
Stop for compressor overload protection	H3			blink-8 times	compressor shell over heat、 lessrefrigerant、 capillary blocked up
Overload protection	H4			blink-6 times	ambient temperature is abominable、 heat exchanger blocked up
Stop for IPMmodule protetion	H5			blink-4 times	IPM mouldel over heat、 low voltage、 silica gel
DC motor (indoor unit) does not operate	H6				DC motor control terminal does not contact well; Blade does not rotate fluently due to incorrect installation; motor or control panel is damaged
Indoor ambient temperature sensor malfunction	F1				terminal connect not reliable、 temperature sensor maifunction
Indoor tube temperature sensor malfunction	F2				terminal connect not reliable、 temperature sensor maifunction
Outdoor ambient temperature sensor malfunction	F3		blink-6 times		terminal connect not reliable、 temperature sensor maifunction
Outdoor tube temperature sensor malfunction	F4		blink-5 times		terminal connect not reliable、 temperature sensor maifunction
Outdoor exhaust temperature sensor malfunction	F5		blink-7 times		terminal connect not reliable、 temperature sensor maifunction
Automatic defrosting	H1			blink-2 times	H1is not error code,it is noemal operation. Just heat pump has this fuction
REMARK:	1.Error codes only can be seen in the type which has the temperature display pcb.maybe some type has not this function,the lamps on the outdoor pcb are avaiable 2.Normally,the communication between indoor unit and outdoor unit is successful, the gree lam				

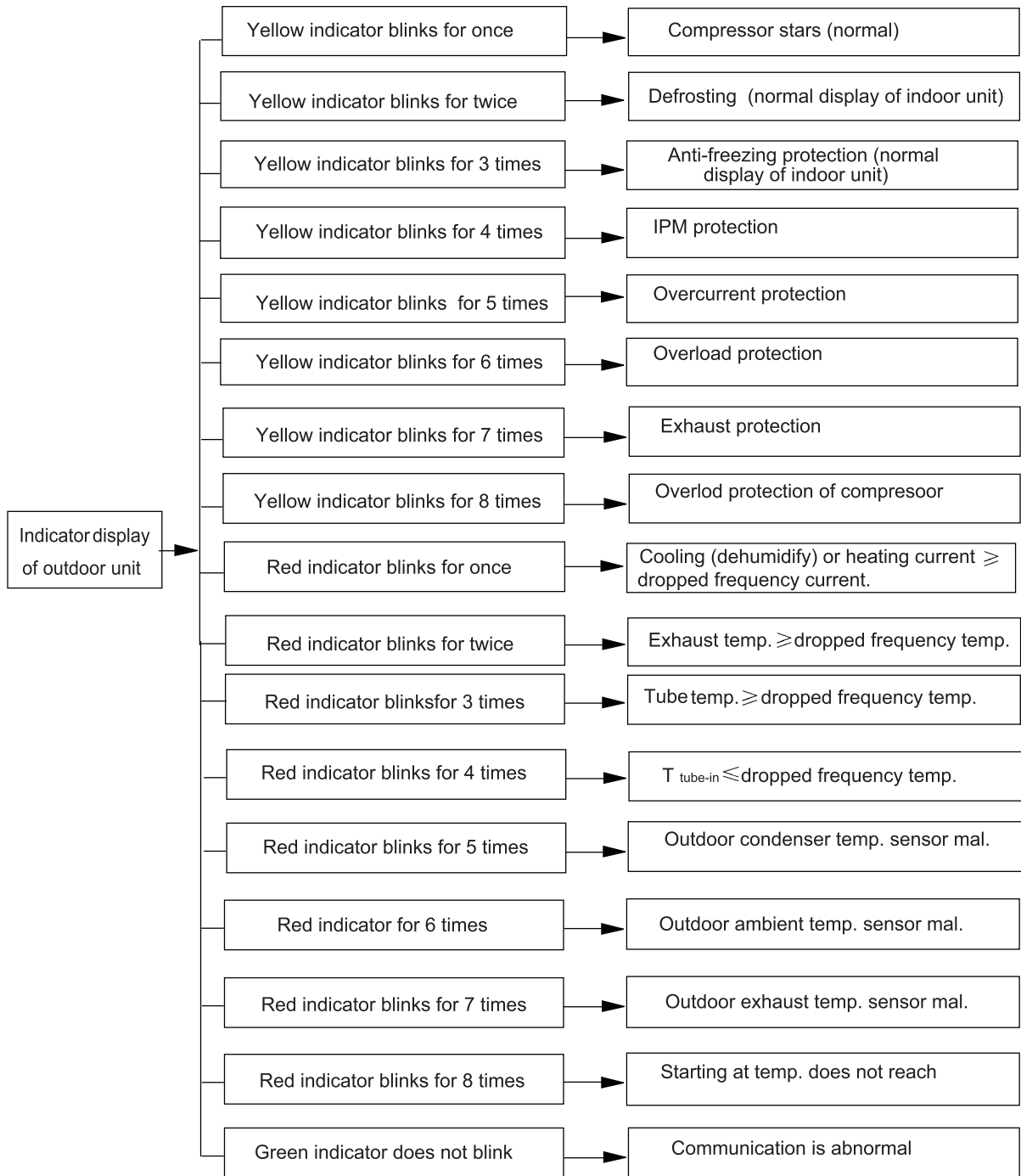

Analysis or processing of some of the malfunction display:

1. Compressor discharge protection

Possible causes: shortage of refrigerant; blockage of air filter; poor ventilation or air flow short pass for condenser; the system has noncondensing gas (such as air, water etc.); blockage of capillary assy (including filter); leakage inside four-way valve causes incorrect operation; malfunction of compressor; malfunction of protection relay; malfunction of discharge sensor; outdoor temperature too high.

Processing method: refer to the malfunction analysis in the above section.

2. Low voltage overcurrent protection

Possible cause: Sudden drop of supply voltage.

3. Communication malfunction

Processing method: Check if communication signal cable is connected reliably.

4. Sensor open or short circuit

Processing method: Check whether sensor is normal, connected with the corresponding position on the controller and if damage of lead wire is found.

5. Compressor over load protection

Possible causes: insufficient or too much refrigerant; blockage of capillary and increase of suction temp.; improper running of compressor, burning in or stuck of bearing, damage of discharge valve; malfunction of protector.

Processing method: adjust refrigerant amount; replace the capillary; replace the compressor; use universal meter to check if the contactor of compressor is fine when it is not overheated, if not replace the protector.

6. System malfunction

i.e. overload protection. When tube temperature (Check the temperature of outdoor heat exchanger when cooling and check the temperature of indoor heat exchanger when heating) is too high, protection will be activated.

Possible causes: Outdoor temperature is too high when cooling; insufficient outdoor air circulation; refrigerant flow malfunction. please refer to the malfunction analysis in the previous section for handling method.

7. IPM module protection

Processing method: Once the module malfunction happens, if it persists for a long time and can not be self-canceled, cut off the power and turn off the unit, and then re-energize the unit again after about 10 min. After repeating the procedure for several times, if the malfunction still exists, replace the module.

9.3 How to Check Simply The Main Part

(1) Capacitor charge fault (Fault with outdoor unit) (AP1 below refers to the outdoor control panel)

Main Check Points:

- Use AC voltmeter to check if the voltage between terminal L and N on the wiring board is within 210VAC~240VAC.
- Is the reactor (L) correctly connected? Is the connection loose or fallen? Is the reactor (L) damaged?

Fault diagnosis process:

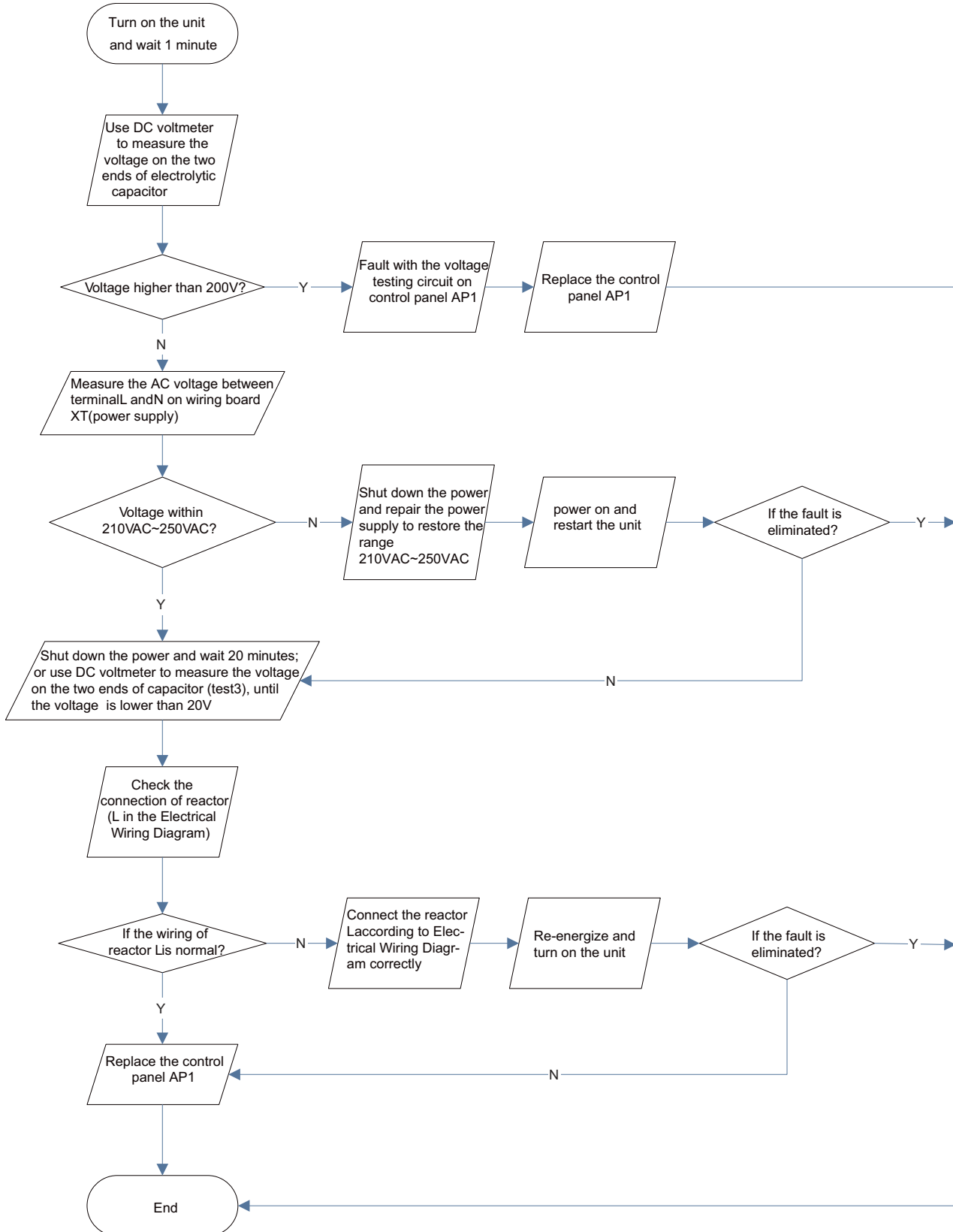

(2) IPM Protection, Out-of-step Fault, Compressor Phase Overcurrent (AP1 below refers to the outdoor control panel)

Main check points:

- Is the connection between control panel AP1 and compressor COMP secure? Loose? Is the connection in correct order?
- Is the voltage input of the machine within normal range? (Use AC voltmeter to measure the voltage between terminal L and N on the wiring board XT)
- Is the compressor coil resistance normal? Is the insulation of compressor coil against the copper tube in good condition?
- Is the working load of the machine too high? Is the radiation good?
- Is the charge volume of refrigerant correct?

Fault diagnosis process:

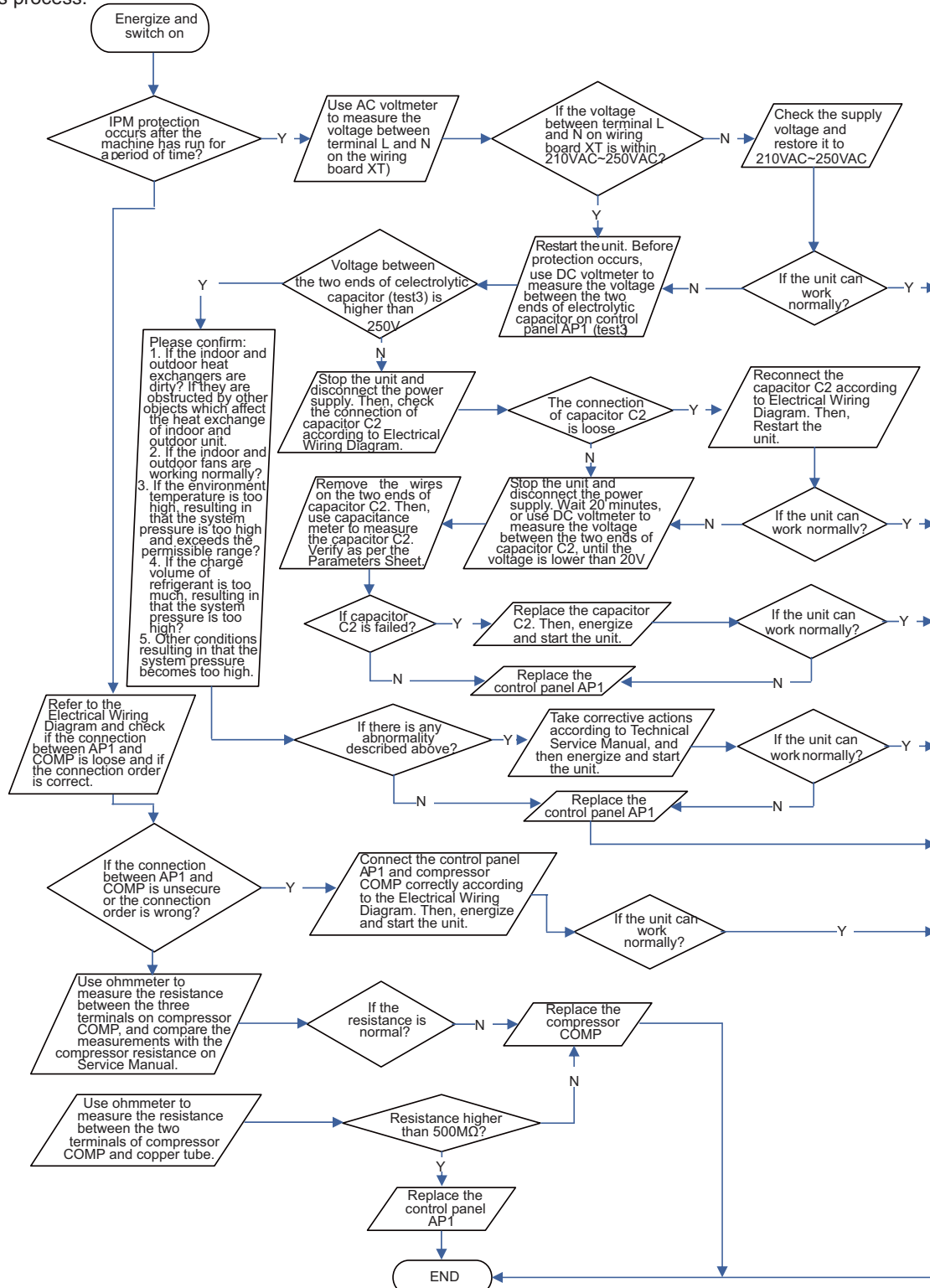

(3)High temperature and overload protection diagnosis (AP1 hereinafter refers to the control board of the outdoor unit)

Mainly detect:

- Is outdoor ambient temperature in normal range?
- Are the outdoor and indoor fans operating normally?
- Is the heat dissipation environment inside and outside the unit good?

Fault diagnosis process:

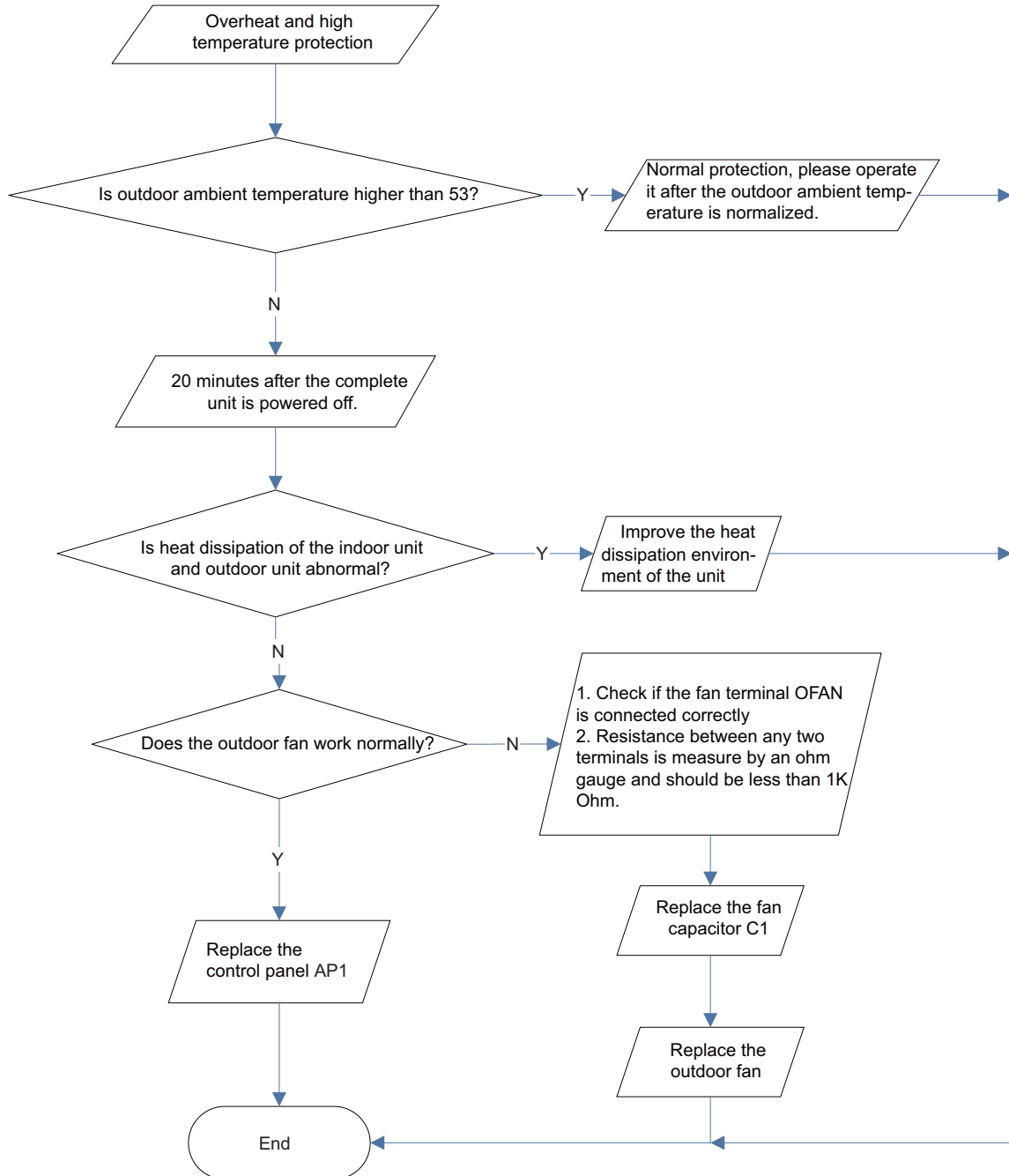

(4) Start-up failure (following AP1 for outdoor unit control board)

Mainly detect:

- Whether the compressor wiring is connected correct?
- Is compressor broken?
- Is time for compressor stopping enough?

Fault diagnosis process:

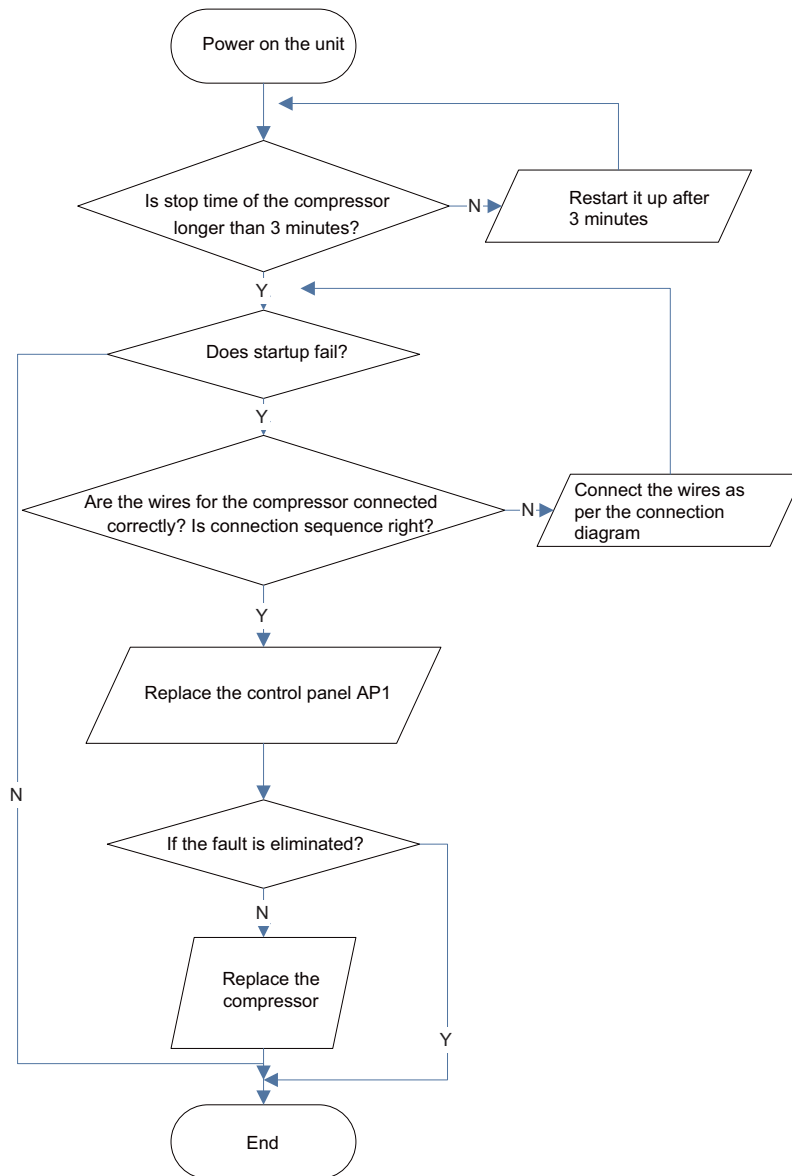

(5) Out of step diagnosis for the compressor (AP1 hereinafter refers to the control board of the outdoor unit)

Mainly detect:

- Is the system pressure too high?
- Is the input voltage too low?

Fault diagnosis process:

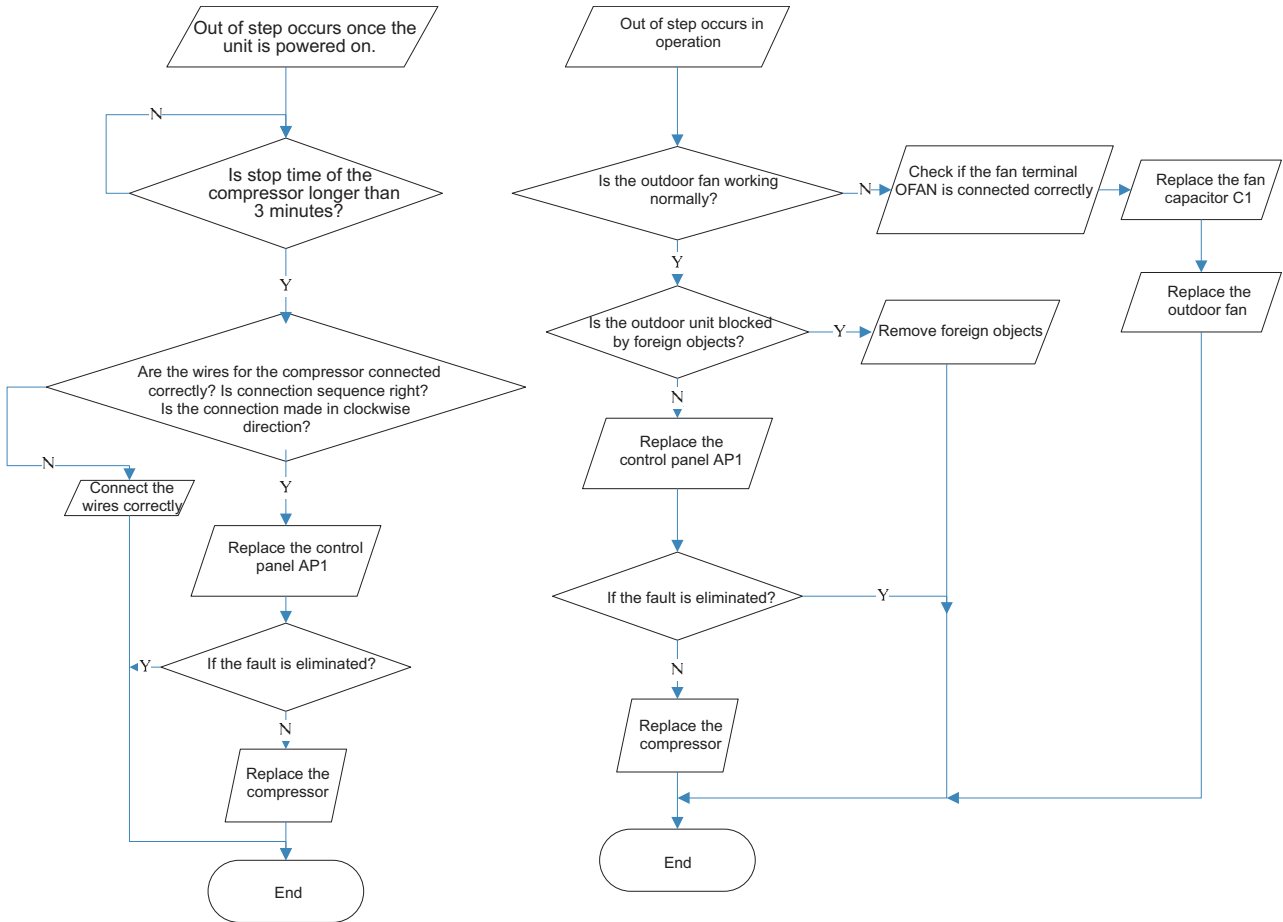

(6)Overload and air exhaust malfunction diagnosis (following AP1 for outdoor unit control board)

Mainly detect:

- Is the PMV connected well or not? Is PMV damaged?
- Is refrigerant leaked?

Fault diagnosis process:

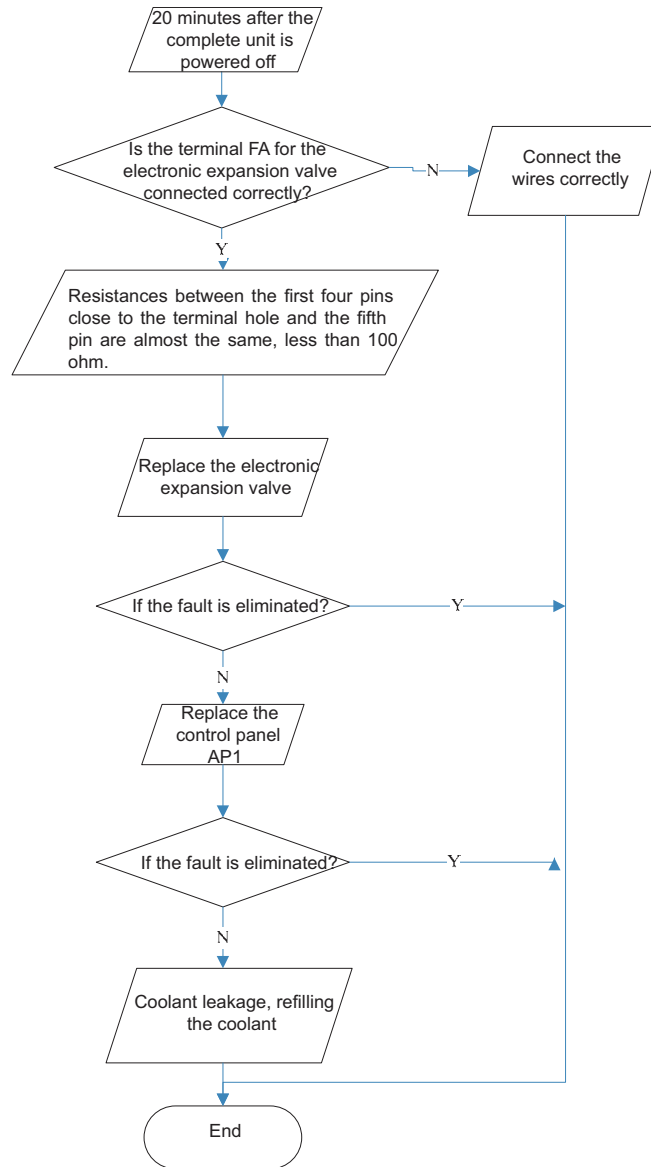

(7)Power factor correct or (PFC) fault (a fault of outdoor unit) (AP1 hereinafter refers to the control board of the outdoor unit)

Mainly detect:

- Check if the reactor (L) of the outdoor unit and the PFC capacitor are broken

Fault diagnosis process:

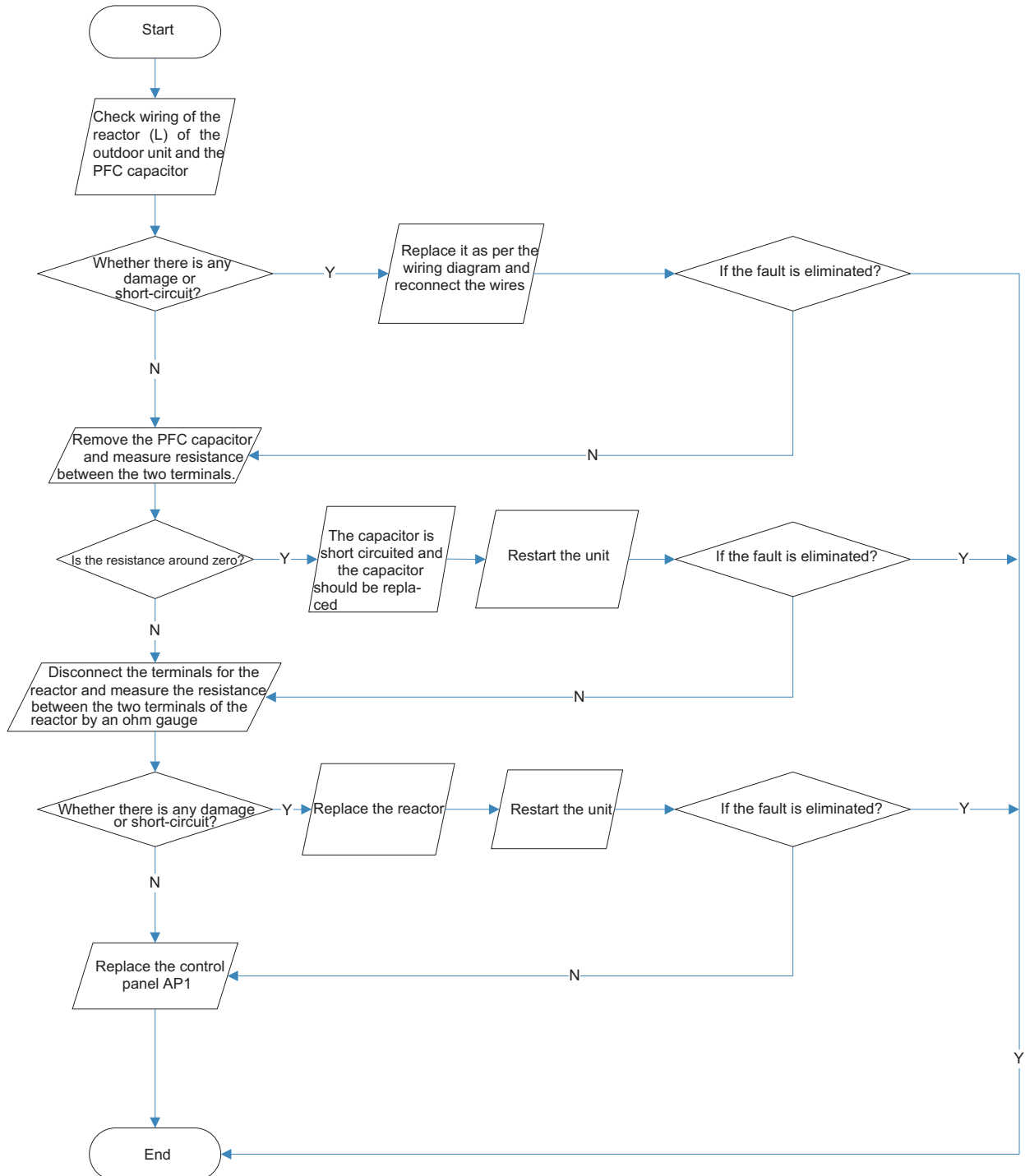

(8) Communication malfunction: (following AP1 for outdoor unit control board)

Mainly detect:

- Is there any damage for the indoor unit mainboard communication circuit? Is communication circuit damaged?
- Detect the indoor and outdoor units connection wire and indoor and outdoor units inside wiring is connect well or not, if is there any damage?

Fault diagnosis process:

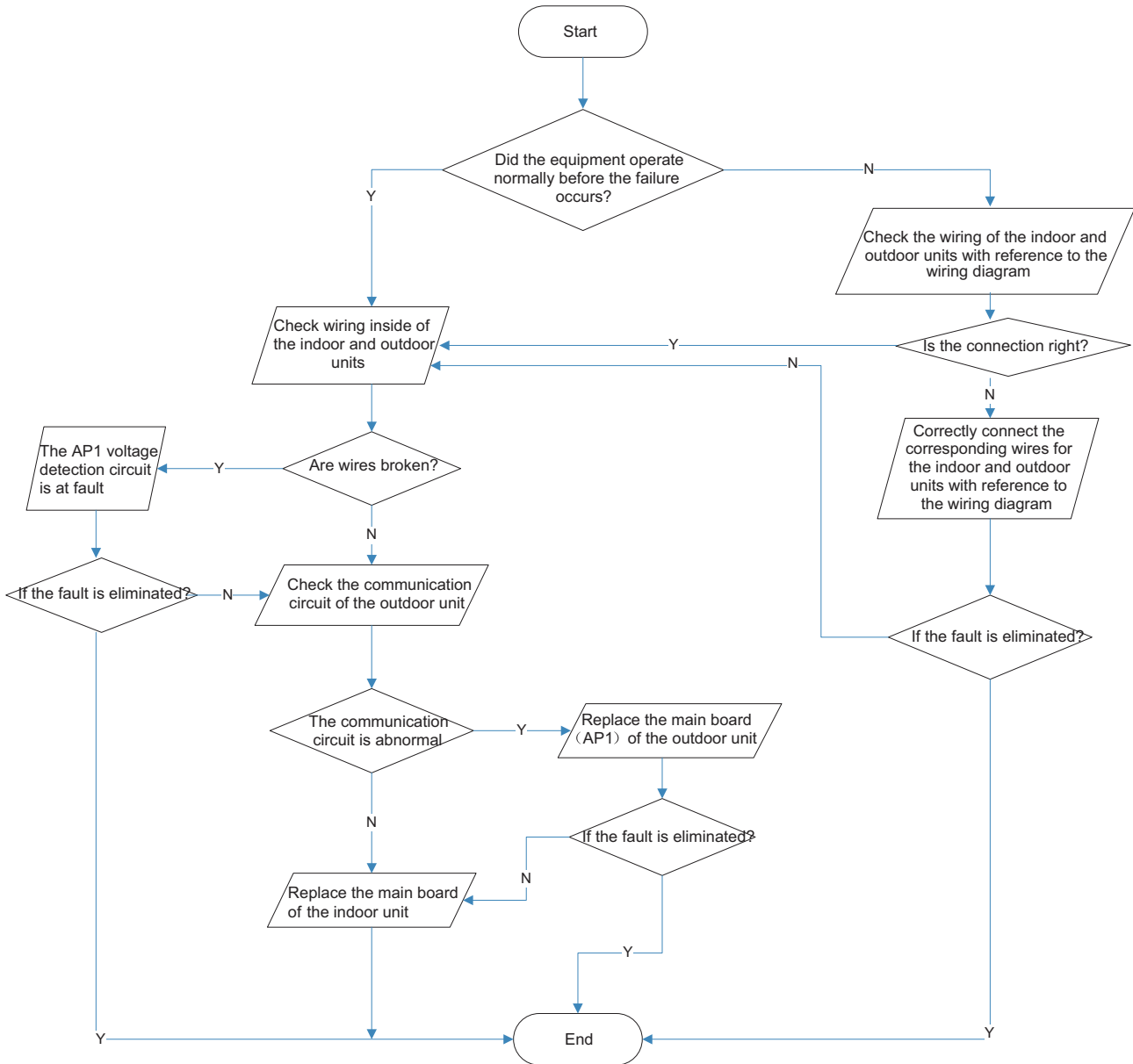

Appendix

Appendix 1: Resistance Table of Ambient Temperature Sensor for Indoor and Outdoor Units(15K)							
Temp. (°C)	Resistance(kΩ)	Temp. (°C)	Resistance(kΩ)	Temp. (°C)	Resistance(kΩ)	Temp. (°C)	Resistance(kΩ)
-19	138.1	20	18.75	59	3.848	98	1.071
-18	128.6	21	17.93	60	3.711	99	1.039
-17	121.6	22	17.14	61	3.579	100	1.009
-16	115	23	16.39	62	3.454	101	0.98
-15	108.7	24	15.68	63	3.333	102	0.952
-14	102.9	25	15	64	3.217	103	0.925
-13	97.4	26	14.36	65	3.105	104	0.898
-12	92.22	27	13.74	66	2.998	105	0.873
-11	87.35	28	13.16	67	2.896	106	0.848
-10	82.75	29	12.6	68	2.797	107	0.825
-9	78.43	30	12.07	69	2.702	108	0.802
-8	74.35	31	11.57	70	2.611	109	0.779
-7	70.5	32	11.09	71	2.523	110	0.758
-6	66.88	33	10.63	72	2.439	111	0.737
-5	63.46	34	10.2	73	2.358	112	0.717
-4	60.23	35	9.779	74	2.28	113	0.697
-3	57.18	36	9.382	75	2.206	114	0.678
-2	54.31	37	9.003	76	2.133	115	0.66
-1	51.59	38	8.642	77	2.064	116	0.642
0	49.02	39	8.297	78	1.997	117	0.625
1	46.6	40	7.967	79	1.933	118	0.608
2	44.31	41	7.653	80	1.871	119	0.592
3	42.14	42	7.352	81	1.811	120	0.577
4	40.09	43	7.065	82	1.754	121	0.561
5	38.15	44	6.791	83	1.699	122	0.547
6	36.32	45	6.529	84	1.645	123	0.532
7	34.58	46	6.278	85	1.594	124	0.519
8	32.94	47	6.038	86	1.544	125	0.505
9	31.38	48	5.809	87	1.497	126	0.492
10	29.9	49	5.589	88	1.451	127	0.48
11	28.51	50	5.379	89	1.408	128	0.467
12	27.18	51	5.197	90	1.363	129	0.456
13	25.92	52	4.986	91	1.322	130	0.444
14	24.73	53	4.802	92	1.282	131	0.433
15	23.6	54	4.625	93	1.244	132	0.422
16	22.53	55	4.456	94	1.207	133	0.412
17	21.51	56	4.294	95	1.171	134	0.401
18	20.54	57	4.139	96	1.136	135	0.391
19	19.63	58	3.99	97	1.103	136	0.382

Appendix 2: Resistance Table of Outdoor and Indoor Tube Temperature Sensors(20K)							
Temp. (°C)	Resistance(kΩ)		Temp. (°C)	Resistance(kΩ)		Temp. (°C)	Resistance(kΩ)
-19	181.4		20	25.01		59	5.13
-18	171.4		21	23.9		60	4.948
-17	162.1		22	22.85		61	4.773
-16	153.3		23	21.85		62	4.605
-15	145		24	20.9		63	4.443
-14	137.2		25	20		64	4.289
-13	129.9		26	19.14		65	4.14
-12	123		27	18.13		66	3.998
-11	116.5		28	17.55		67	3.861
-10	110.3		29	16.8		68	3.729
-9	104.6		30	16.1		69	3.603
-8	99.13		31	15.43		70	3.481
-7	94		32	14.79		71	3.364
-6	89.17		33	14.18		72	3.252
-5	84.61		34	13.59		73	3.144
-4	80.31		35	13.04		74	3.04
-3	76.24		36	12.51		75	2.94
-2	72.41		37	12		76	2.844
-1	68.79		38	11.52		77	2.752
0	65.37		39	11.06		78	2.663
1	62.13		40	10.62		79	2.577
2	59.08		41	10.2		80	2.495
3	56.19		42	9.803		81	2.415
4	53.46		43	9.42		82	2.339
5	50.87		44	9.054		83	2.265
6	48.42		45	8.705		84	2.194
7	46.11		46	8.37		85	2.125
8	43.92		47	8.051		86	2.059
9	41.84		48	7.745		87	1.996
10	39.87		49	7.453		88	1.934
11	38.01		50	7.173		89	1.875
12	36.24		51	6.905		90	1.818
13	34.57		52	6.648		91	1.736
14	32.98		53	6.403		92	1.71
15	31.47		54	6.167		93	1.658
16	30.04		55	5.942		94	1.609
17	28.68		56	5.726		95	1.561
18	27.39		57	5.519		96	1.515
19	26.17		58	5.32		97	1.47
						98	1.427
						99	1.386
						100	1.346
						101	1.307
						102	1.269
						103	1.233
						104	1.198
						105	1.164
						106	1.131
						107	1.099
						108	1.069
						109	1.039
						110	1.01
						111	0.983
						112	0.956
						113	0.93
						114	0.904
						115	0.88
						116	0.856
						117	0.833
						118	0.811
						119	0.77
						120	0.769
						121	0.746
						122	0.729
						123	0.71
						124	0.692
						125	0.674
						126	0.658
						127	0.64
						128	0.623
						129	0.607
						130	0.592
						131	0.577
						132	0.563
						133	0.549
						134	0.535
						135	0.521
						136	0.509

Appendix 3: Resistance Table of Outdoor Discharge Temperature Sensor(50K)

Temp. (°C)	Resistance(kΩ)	Temp. (°C)	Resistance(kΩ)	Temp. (°C)	Resistance(kΩ)	Temp. (°C)	Resistance(kΩ)
-29	853.5	10	98	49	18.34	88	4.754
-28	799.8	11	93.42	50	17.65	89	4.609
-27	750	12	89.07	51	16.99	90	4.469
-26	703.8	13	84.95	52	16.36	91	4.334
-25	660.8	14	81.05	53	15.75	92	4.204
-24	620.8	15	77.35	54	15.17	93	4.079
-23	580.6	16	73.83	55	14.62	94	3.958
-22	548.9	17	70.5	56	14.09	95	3.841
-21	516.6	18	67.34	57	13.58	96	3.728
-20	486.5	19	64.33	58	13.09	97	3.619
-19	458.3	20	61.48	59	12.62	98	3.514
-18	432	21	58.77	60	12.17	99	3.413
-17	407.4	22	56.19	61	11.74	100	3.315
-16	384.5	23	53.74	62	11.32	101	3.22
-15	362.9	24	51.41	63	10.93	102	3.129
-14	342.8	25	49.19	64	10.54	103	3.04
-13	323.9	26	47.08	65	10.18	104	2.955
-12	306.2	27	45.07	66	9.827	105	2.872
-11	289.6	28	43.16	67	9.489	106	2.792
-10	274	29	41.34	68	9.165	107	2.715
-9	259.3	30	39.61	69	8.854	108	2.64
-8	245.6	31	37.96	70	8.555	109	2.568
-7	232.6	32	36.38	71	8.268	110	2.498
-6	220.5	33	34.88	72	7.991	111	2.431
-5	209	34	33.45	73	7.726	112	2.365
-4	198.3	35	32.09	74	7.47	113	2.302
-3	199.1	36	30.79	75	7.224	114	2.241
-2	178.5	37	29.54	76	6.998	115	2.182
-1	169.5	38	28.36	77	6.761	116	2.124
0	161	39	27.23	78	6.542	117	2.069
1	153	40	26.15	79	6.331	118	2.015
2	145.4	41	25.11	80	6.129	119	1.963
3	138.3	42	24.13	81	5.933	120	1.912
4	131.5	43	23.19	82	5.746	121	1.863
5	125.1	44	22.29	83	5.565	122	1.816
6	119.1	45	21.43	84	5.39	123	1.77
7	113.4	46	20.6	85	5.222	124	1.725
8	108	47	19.81	86	5.06	125	1.682
9	102.8	48	19.06	87	4.904	126	1.64

Note: The information above is for reference only.

10. Removal Procedure

10.1 Removal Procedure of Indoor Unit



Warning

Be sure to wait for a minimum of 10 minutes after turning off all power supplies before disassembly.

NOTE: Take A1 panel for example.

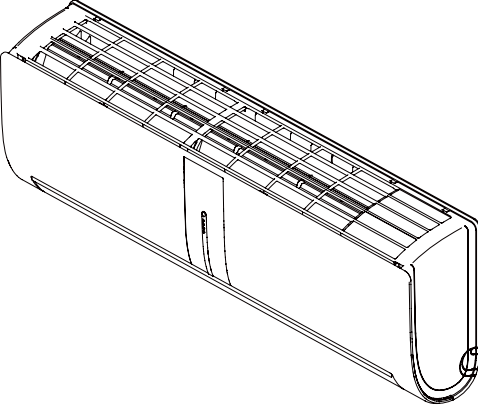
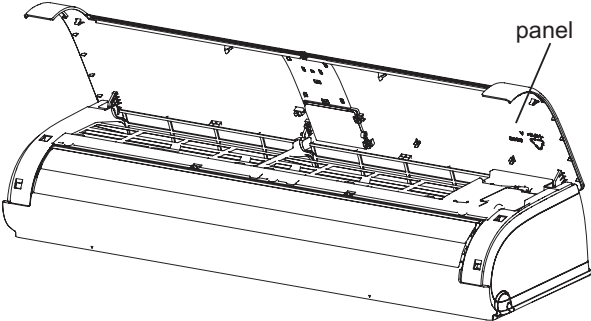
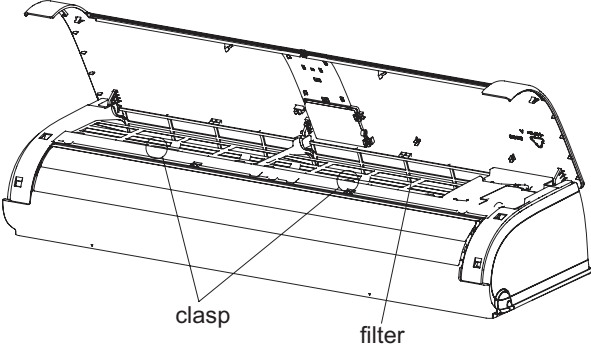
Steps	Procedure
1. Before disassembly	
2. Remove filter sub-assy	<p data-bbox="124 1301 718 1361">a Loosen the clasps at the left side and right side of the panel, and then open the front panel.</p>  <p data-bbox="124 1749 718 1832">b Loosen the clasps of the filter sub-assy; push the filter inwards, and then pull it upwards to remove the filter sub-assy.</p> 

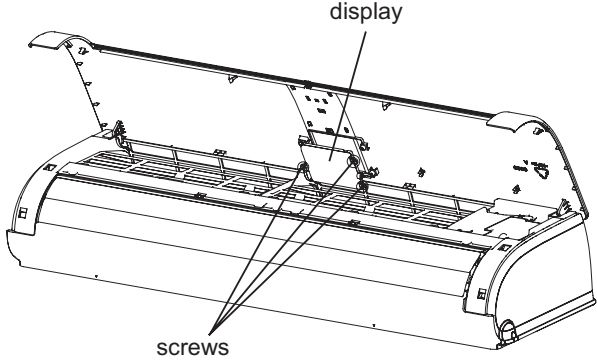
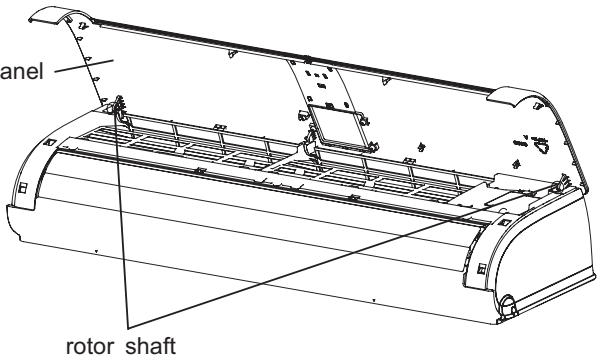
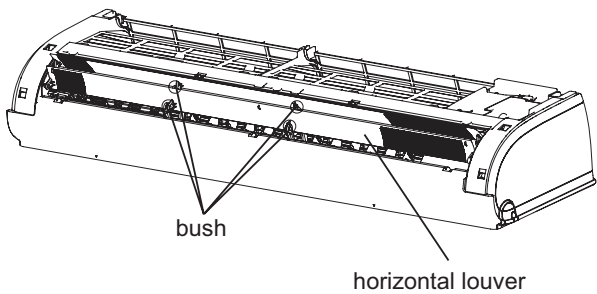
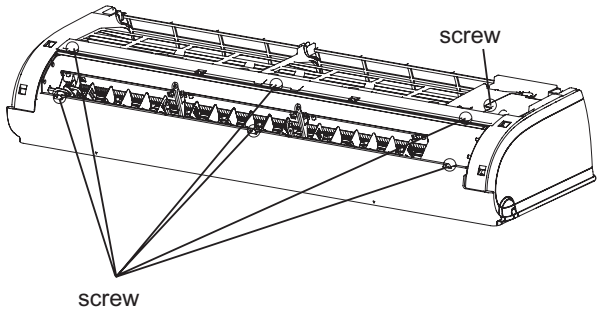
Steps	Procedure	
3.Remove panel		
a	Open the panel; remove the screws fixing the display on the panel.	 <p>A perspective view of the device's front panel. A line points to the 'display' area on the panel. Another line points to several 'screws' that are being removed from the panel's surface.</p>
b	Push the rotor shaft on both sides of the panel to make it separate from the groove, and then remove the panel.	 <p>A perspective view of the device's front panel. A line points to the 'panel' being lifted away from the device. Another line points to the 'rotor shaft' which is now visible after the panel has been partially removed.</p>
4.Remove horizontal louver		
	Push the bush of the horizontal louver. Bend the horizontal louver outwards and then remove it.	 <p>A perspective view of the device's front panel. A line points to a 'bush' located on the front edge of the panel. Another line points to the 'horizontal louver' which is being bent outwards.</p>
5.Remove front case		
a	Open the screw cap. Remove the 6 screws fixing the front case and the screw fixing the electric box cover 2.	 <p>A perspective view of the device's front panel. A line points to a 'screw' on the top edge of the panel. Another line points to a 'screw' on the bottom edge of the panel.</p>

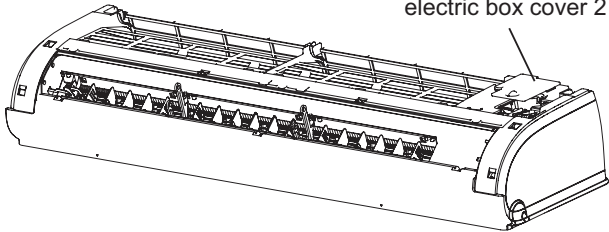
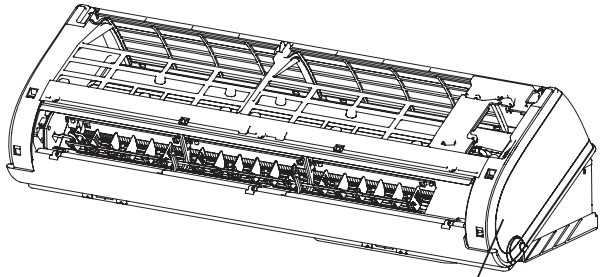
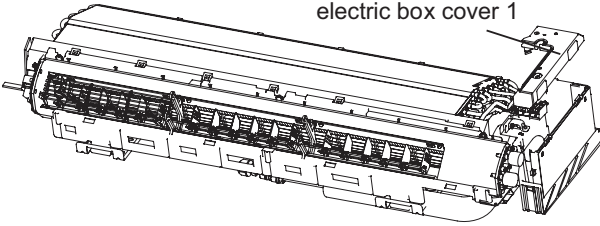
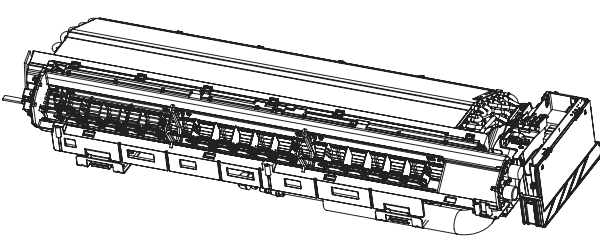
Steps	Procedure	
b	Remove the electric box cover 2.	 <p style="text-align: right;">electric box cover 2</p>
c	Loosen the clasp of the front case. Raise the front case to remove it.	 <p style="text-align: right;">front case</p>
6.Remove the electric box		
a	Loosen the clasp connecting the electric box cover 1 and electric box. Remove the electric box cover 1.	 <p style="text-align: right;">electric box cover 1</p>
b	Disconnect the terminal of the motor and the step motor.	

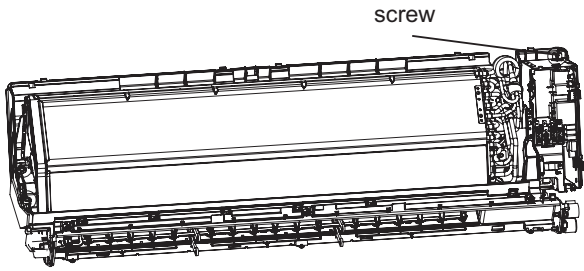
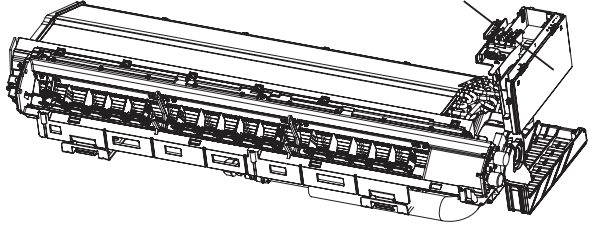
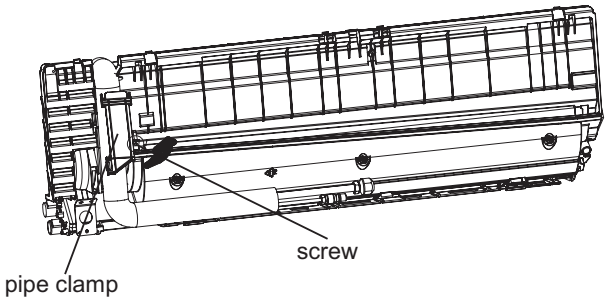
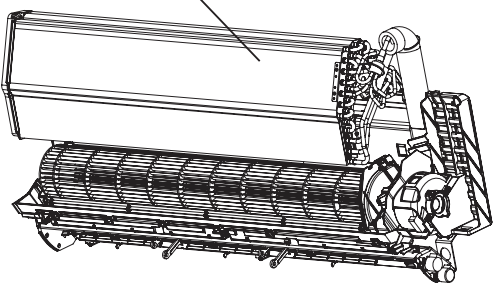
Steps	Procedure	
c	Remove the screw fixing the electric box.	 <p>screw</p>
d	Remove the electric box.	 <p>electric box</p>
7.Remove the evaporator		
a	Remove the screw of the pipe clamp. Remove the pipe clamp.	 <p>pipe clamp</p> <p>screw</p>
b	Remove the screw fixing the evaporator and the chassis. Adjust the pipe and remove the evaporator.	 <p>evaporator</p>

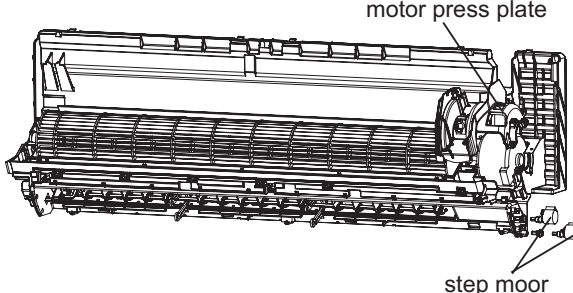
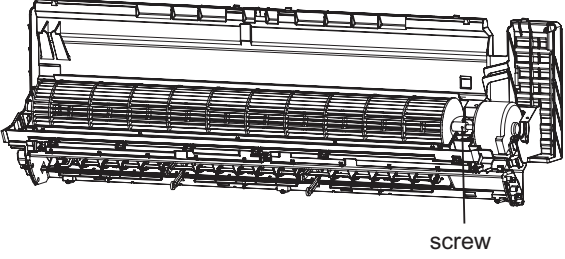
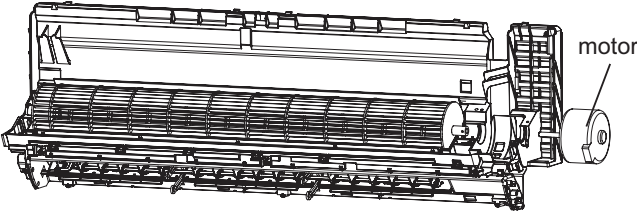
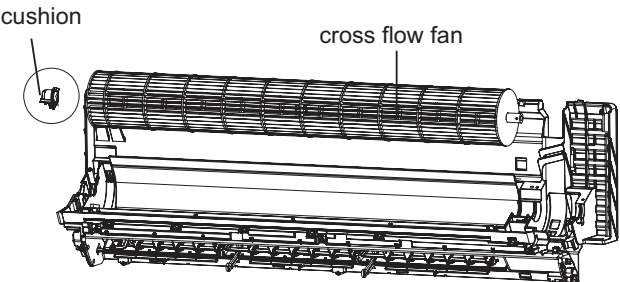
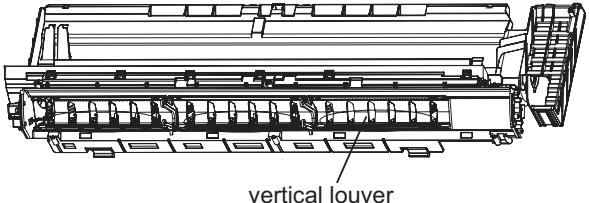
Steps	Procedure	
8.Remove the cross flow fan and the motor		
a	Remove the screws fixing the motor press plate and the step motor. Remove the motor press plate and the step motor.	
b	Remove the screws fixing the cross flow fan and the motor.	
c	Remove the motor.	
d	Remove the cushion of the bearing.	
9.Remove the vertical louver		
	Loosen the clasp of the vertical louver and the chassis. Remove the vertical louver.	

10.2 Removal Procedure of Outdoor Unit



Warning

Be sure to wait for a minimum of 10 minutes after turning off all power supplies before disassembly.

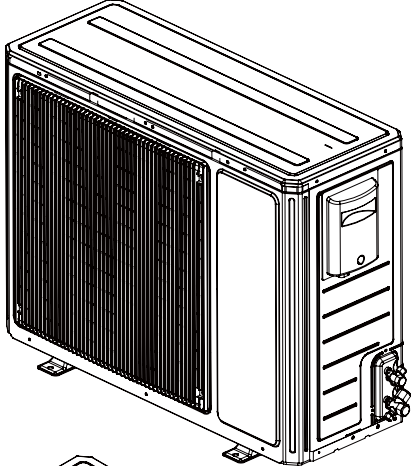
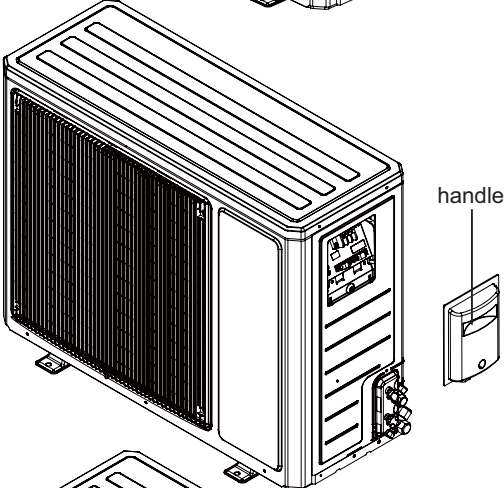
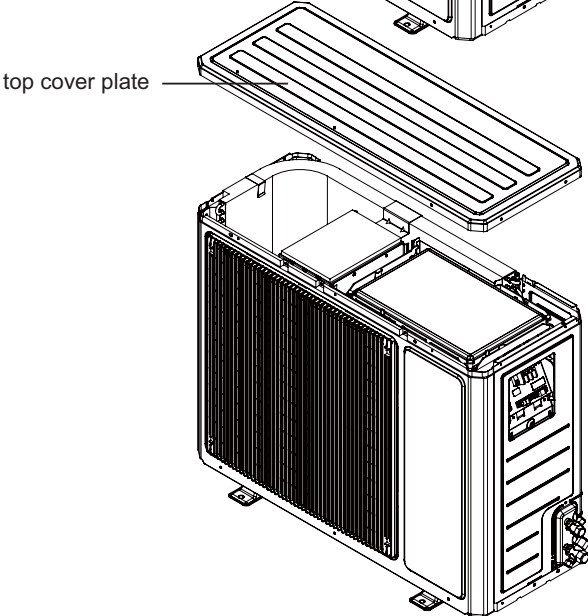
Steps	Procedure
<p>1.Remove handle and top cover</p>	
<p>a</p>	<p>Before disassembly.</p> 
<p>b</p>	<p>Twist off the screws used for fixing the handle, pull the handle upward to remove it.</p>  <p style="text-align: right;">handle</p>
<p>c</p>	<p>Twist off the screws used for fixing the top cover, pull the top cover upward to remove it.</p>  <p style="text-align: left;">top cover plate</p>

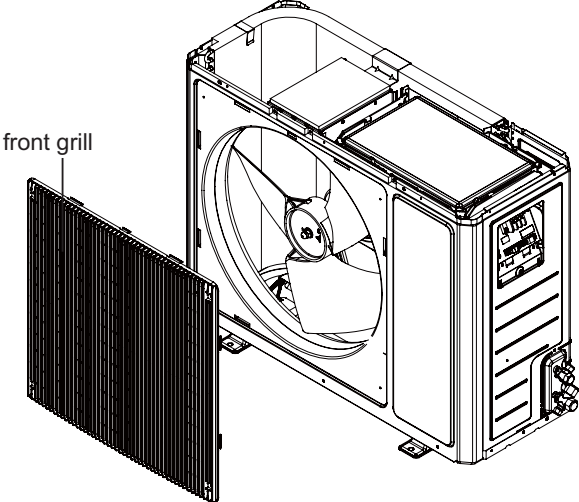
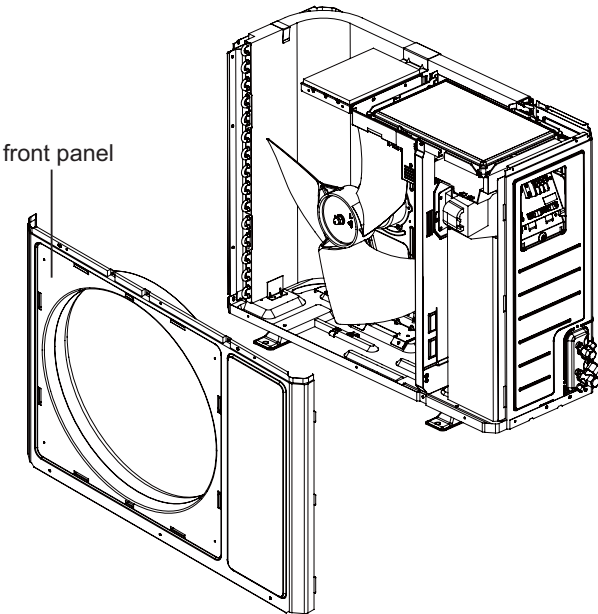
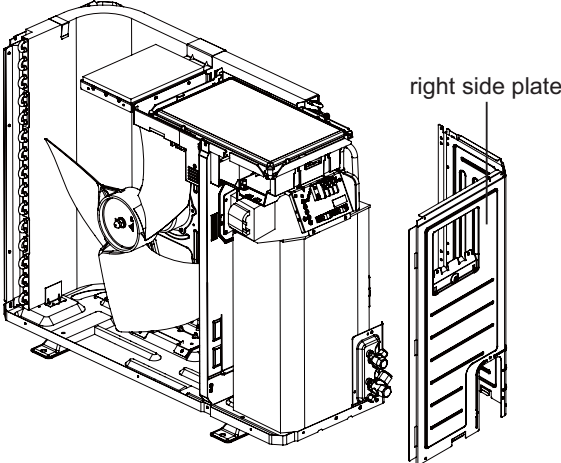
Steps	Procedure
<p>2.Remove front grill</p> <p>Remove the screws connecting the front grille and the front panel. Remove the front grille.</p>	 <p>The diagram shows a perspective view of the device's front. A rectangular front grill with vertical slats is shown being pulled away from the front panel. A label 'front grill' with a leader line points to the grill. The internal components, including a fan and various electronic parts, are visible through the opening.</p>
<p>3.Remove front panel</p> <p>Twist off the screws fixing the panel, pull it upward, loosen the clasp on the right side, rotate it to the left and then remove the front panel.</p>	 <p>The diagram shows the front panel being lifted and rotated away from the device. A label 'front panel' with a leader line points to the panel. The panel is shown in a partially detached state, revealing the internal components more clearly.</p>
<p>4.Remove right side plate</p> <p>Remove the screws connecting the right side plate with the chassis, the valve support and the electric box, and then remove the right side plate.</p>	 <p>The diagram shows the right side plate being removed from the device. A label 'right side plate' with a leader line points to the plate. The plate is shown being lifted away from the main chassis, revealing the internal components on the right side.</p>

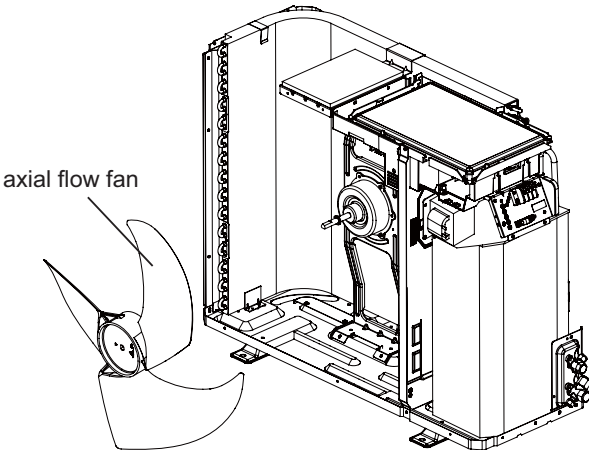
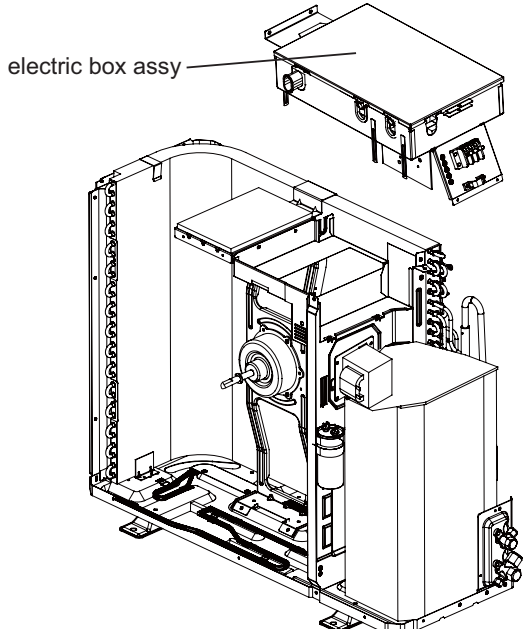
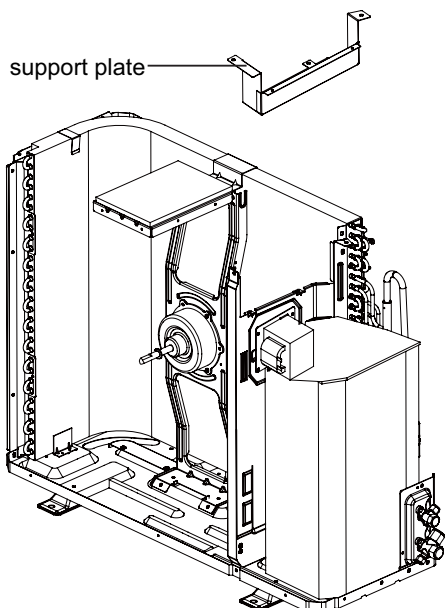
Steps	Procedure
<p>5.Remove axial flow fan</p>	<p>Remove the nuts fixing the blade and then remove the axial flow fan.</p> 
<p>6.Remove electric box assy</p>	<p>Remove the screws fixing the electric box sub-assy;loosen the wire bundle; pull out the wiring terminals and then pull the electric box upwards to remove it.</p> 
<p>7. Remove support plate</p>	<p>Remove screws fixing support plate,and then remove the support plate.</p> 

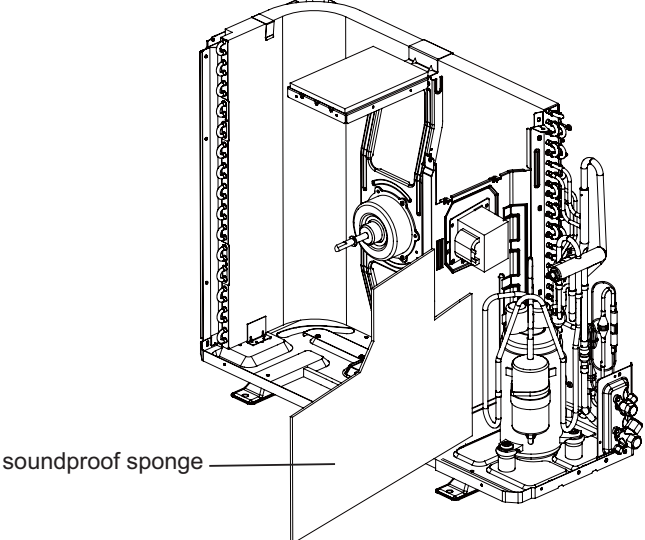
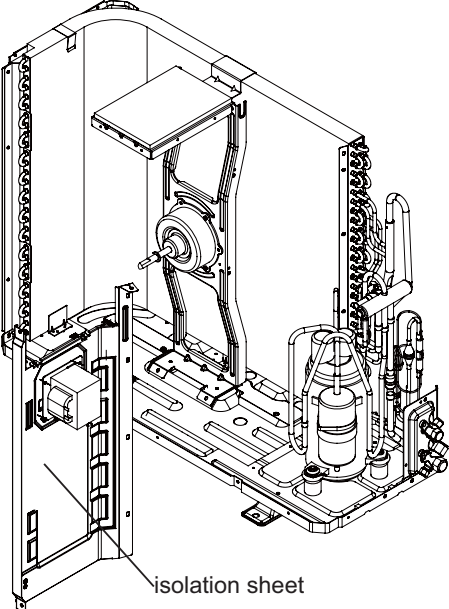
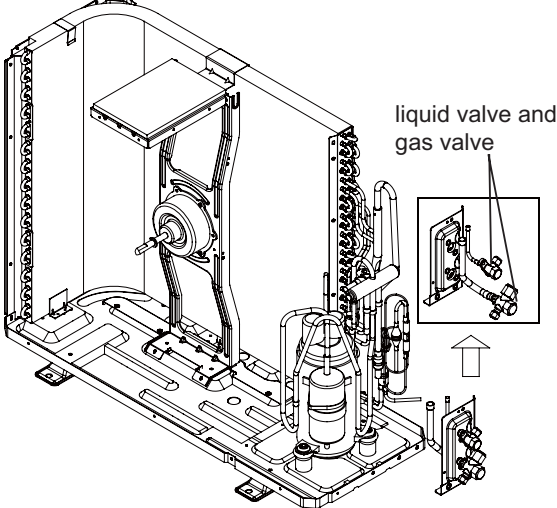
Steps	Procedure
<p data-bbox="150 264 528 293">8.Remove soundproof sponge</p>	<p data-bbox="248 445 687 499">Remove the soundproof sponge wrapping the compressor.</p>  <p data-bbox="762 712 965 741">soundproof sponge</p>
<p data-bbox="150 846 467 875">9.Remove isolation sheet</p>	<p data-bbox="248 1072 687 1126">Remove screws fixing isolation sheet and then remove the isolation sheet.</p>  <p data-bbox="1107 1429 1265 1458">isolation sheet</p>
<p data-bbox="150 1509 619 1538">10.Remove liquid valve and gas valve</p>	<p data-bbox="248 1632 687 1995">Remove the 2 bolts fixing the gas valve and unsolder the welding joint between the gas valve and the air-return pipe to remove the gas valve. (NOTE: Discharge the refrigerant completely before unsoldering;when unsoldering, wrap the gas valve with a wet cloth completely to avoid damage to the valve caused by high temperature). Remove the 2 bolts fixing the liquid valve and unsolder the welding joint connecting the liquid valve to the Y-type pipe to remove the liquid valve.</p>  <p data-bbox="1331 1621 1497 1675">liquid valve and gas valve</p>

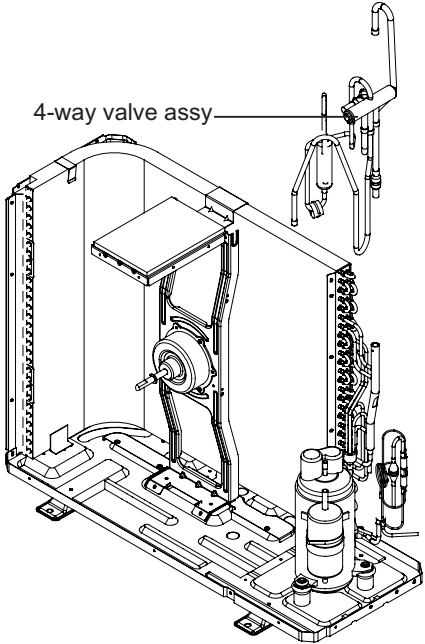
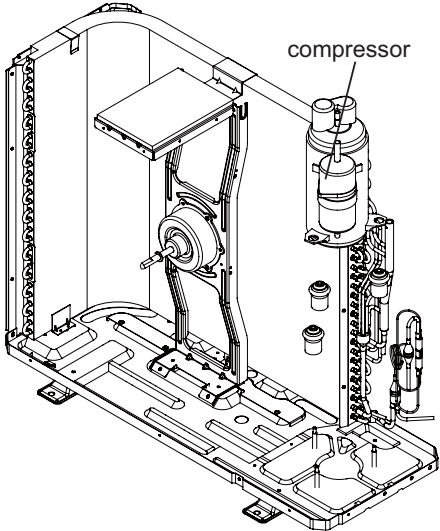
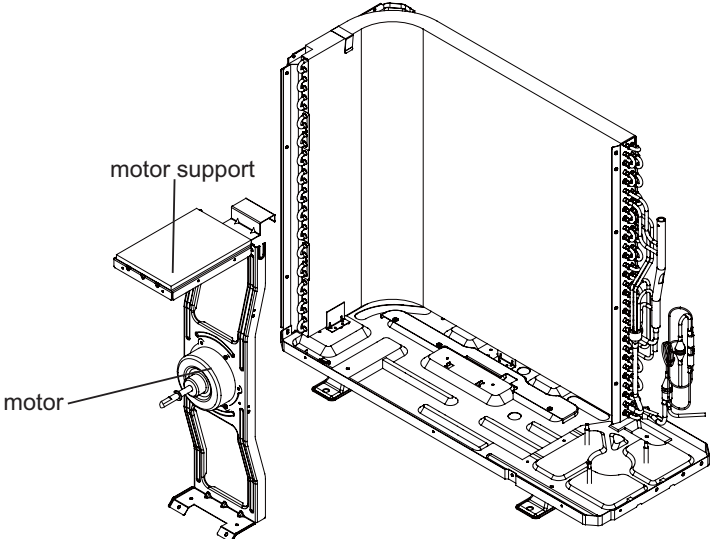
Steps	Procedure	Procedure
<p>11.Remove 4-way valve assy</p>	<p>unsolder the pipeline connecting the compressor and the condenser assy,and then remove the 4-way valve assy.</p>	
<p>12.Remove compressor</p>	<p>Twist off the three foot nuts on compressor and then remove the compressor.</p>	
<p>13.Remove motor support and motor</p>	<p>Remove the 4 tapping screws fixing the motor;disconnect the leading wire insert of the motor and then remove the motor. Remove the 2 tapping screws fixing the motor support and then pull the motor support upwards to remove it.</p>	

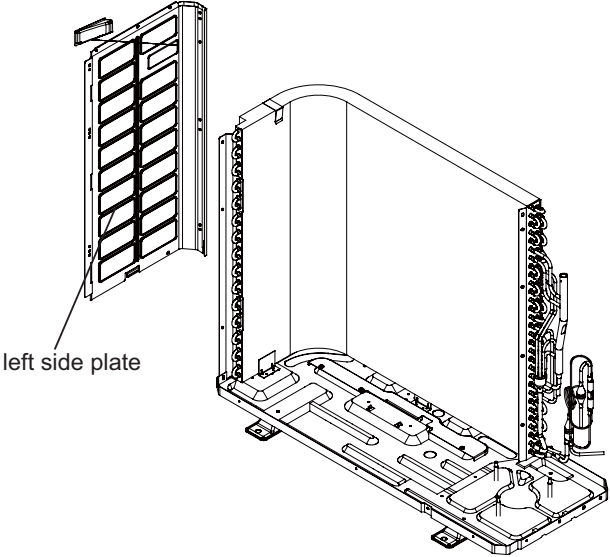
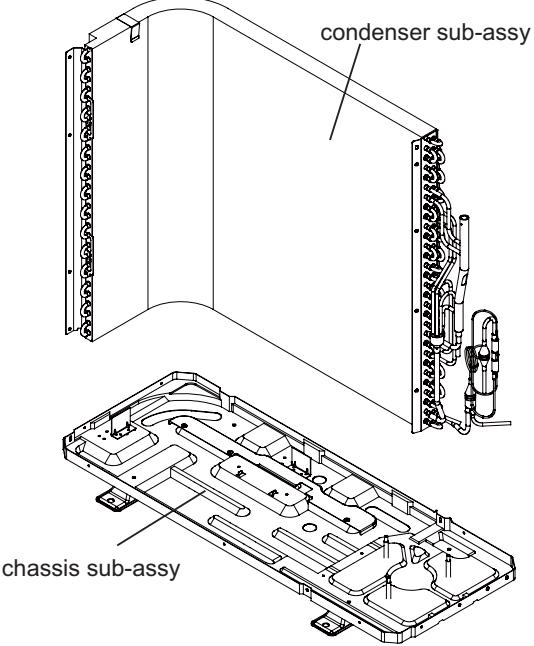
Steps	Procedure
<p data-bbox="150 264 464 293">14.Remove left side plate</p> <p data-bbox="248 450 655 528">Remove the screws connecting the left side plate and the chassis, and then remove the left side plate.</p>	 <p data-bbox="810 607 951 636">left side plate</p> <p>The diagram illustrates the removal of the left side plate. On the left, a separate view shows the left side plate, which is a vertical panel with a grid of horizontal slats. On the right, a perspective view shows the main chassis assembly with the left side plate being lifted away from its position. The chassis is a complex metal frame with various components and wiring visible on the right side.</p>
<p data-bbox="145 846 711 902">15.Remove chassis sub-assy and condenser sub-assy.</p> <p data-bbox="248 1070 608 1126">Remove the chassis sub-assy and condenser sub-assy.</p>	 <p data-bbox="1182 875 1398 904">condenser sub-assy</p> <p data-bbox="863 1406 1043 1435">chassis sub-assy</p> <p>The diagram illustrates the removal of the chassis and condenser sub-assemblies. On the left, a perspective view shows the condenser sub-assembly, which is a vertical panel with a grid of horizontal slats, similar to the left side plate. On the right, a perspective view shows the main chassis assembly with the condenser sub-assembly being lifted away from its position. The chassis is a complex metal frame with various components and wiring visible on the right side.</p>



GREE ELECTRIC APPLIANCES, INC. OF ZHUHAI

Add: Jinji west Rd. Qianshan Zhuhai Guangdong China
Tel: 86-756-8522219 (After sale Service Dept)
Post code: 519070