



# ***Service Manual***

## **U-MATCH HEAT PUMP AIR CONDITIONING**

(GC201902-I)

Capacity: 5.0kW~16.0kW

Rate Frequency: 50Hz

Operation Range: -15°C~48°C

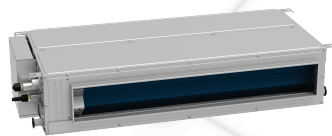
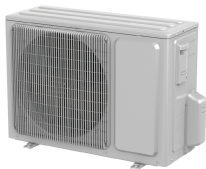



## Foreword

Thank you for choosing Gree U-Match air conditioners. In order to correctly install and use our units, and for the satisfactory operation effect, please read this manual carefully.

This manual specifies safe operation requirements from perspectives of product introduction, control, troubleshooting and maintenance, as well as basic principles and implementation methods. Professional operators must abide by relevant national (local) safety requirements and technical specifications set forth in this manual during operations; otherwise, the air conditioning system may fail or be damaged, and personnel safety accident may also occur.

## Safety Notice

	Before using the air conditioner, please first read the instruction manual.
	Before installing the air conditioner, please first read the instruction manual.
	Before repairing the air conditioner, please first read the technical service manual.

# CONTENTS

<b>Safety Notice on Maintenance .....</b>	<b>1</b>
<b>Safety Notice on Operation .....</b>	<b>2</b>
<b>1. Product Introduction .....</b>	<b>3</b>
1.1 Lists of Units .....	3
<b>2. Control .....</b>	<b>8</b>
2.1 Operation Mode.....	8
2.2 Control Mode.....	10
2.3 Functions.....	11
<b>3. Troubleshooting.....</b>	<b>20</b>
3.1 Wiring Diagrams .....	20
3.2 PCB Layout .....	25
3.3 Error Code .....	28
3.4 Troubleshooting.....	29
3.5 Failures Not Caused by Errors.....	46
<b>4. Maintenance .....</b>	<b>47</b>
4.1 System Diagram.....	47
4.2 Connection Pipe Vacuum Pumping .....	47
4.3 Refrigerant Charging .....	48
4.4 Removal of Major Components.....	50
4.5 Explosive View and Lists of Parts.....	87
<b>Appendices.....</b>	<b>142</b>
1. Resistance/temperature lists of temperature sensors .....	142
2. Temperature/Pressure List of Refrigerant.....	150
3. Operation Tools.....	150

# Safety Notice on Maintenance



## PROHIBITED:

1. Do not pierce or burn.
2. Please note that refrigerant may be odorless.
3. The appliance shall be stored in a room without continuously operating ignition sources (For example: open flames, an operating gas appliance or an operating electric heater).
4. Using unsuitable parts or tools may lead to electric shock or fire hazard.
5. If refrigerant leaks during maintenance, please ventilate the room immediately. Heavy leakage may lead to breathing difficulty, severe injury or death.
6. Disconnect power before disassembling the appliance for maintenance.



## WARNING:

1. If the working place is more than 2m's high, please wear a safety helmet, gloves and a safety belt.
2. Never mix any other substances except the specified refrigerant into the refrigerant circuit.
3. When re-locating the appliance, check whether the new location is strong enough to withstand the weight of the appliance.
4. If there is refrigerant leak, please fix the leak before charging in the refrigerant. After refrigerant is charged, check for refrigerant leaks. If you cannot spot the leak, stop the maintenance work. Please evacuate the system and close the service valve to prevent refrigerant leaking into the room.
5. Prepare suitable tools and protectors.
6. If you need to carry out maintenance or check the electric circuit without cutting off the power, please be careful not to touch the electrical parts.



## NOTICE:

1. If the appliance is maintained at a humid place, it should be grounded to avoid electric shock.
2. Never repair the unit with wet hands. Operating the unit with wet hands may lead to electric shock.
3. If the unit is not correctly grounded, please check and fix it.
4. Before cleaning the unit, please disconnect power to prevent the inner fan from starting up and running at high speed; otherwise personal injury may occur.
5. Measure the insulation resistance after maintenance. The resistance must be 1M or higher. Bad insulation may lead to electric shock.
6. Welding and cutting work must be done in a well-ventilated place.
7. Gas appliances, heaters and other fire sources should be kept away from the installation and maintenance site.
8. Maintenance should be done according to suggestions of the manufacturer.
9. Maintenance should be done only after the refrigerant is completely reclaimed from the unit.



## OBSERVED:

1. After the maintenance work is done, check the drainage of indoor unit.
2. Do not tilt the unit, otherwise, water may spill out from the unit and make the floor and furniture wet.
3. Disassembly of the unit, handling of the refrigerant, oil and accessories should all be done according to applicable local rules and regulations.

# Safety Notice on Operation



## PROHIBITED:

1. Never try to modify the unit, otherwise, it may cause electric shock, overheat or fire hazard.
2. If the power cord or conducting wires are scratched or destroyed, please replace them.
3. Never use connected or extended power cord or share the power socket with other appliances.
4. Prepare a specialized power circuit for the appliance.



## WARNING:

1. If the power plug is dirty, please clean it before inserting it to the power socket. If the power plug is loose, please tightening it up.
2. Do not damage the power cord. A damaged or refitted power cord may lead to electric shock or fire hazard.
3. Check frequently whether the appliance is in good condition.





## NOTICE:

1. After changing the batteries of remote control, please discard them to avoid being swallowed by children.
2. When the unit is working, do not remove the fan cover.
3. Do not use organic solvents to wipe the controller operating panel.
4. Before cleaning the unit, cut off the power supply.

# 1. Product Introduction

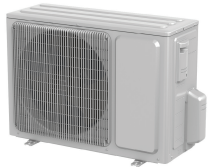
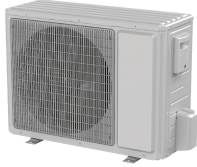
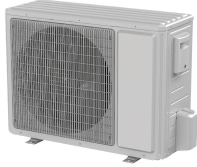
## 1.1 Lists of Units





Model	Power Supply	Finished Product Code	Appearance
	V/Ph/Hz		
GU50W/A1-K	220V-240V ~50Hz	CF021W2630	
GU71W/A1-K		CF021W2620	
GU85W/A1-K		CF021W2650	
GU100W/A1-M	380V-415V 3N ~50Hz	CF021W2640	
GU125W/A1-M		CF021W2660	
GU140W/A1-M		CF021W2520	
GU160W/A1-M		CF021W2560	

Note: 1Ton =12000Btu/h = 3.517kW

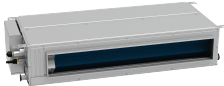
If one outdoor unit is to be connected with multiple indoor units, the indoor units must have the same cooling capacity and be of the same type.

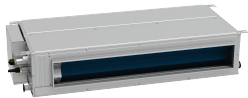
## 1.1.2 List of IDUs

Model		Rated Cooling (kW)	Rated Heating (kW)	Power Supply	Finished Product Code	Appearance
				(V,Ph,Hz)		
Cassette Type	GUD50T/A1-K	4.8	5.0	220V-240V ~50Hz	ET010N1750	
	GU71T/A1-K	7.1	7.4		ET010N1760	
	GU85T/A1-K	8.3	9.2		ET010N1820	
	GU100T/A1-K	10.0	12.0		ET010N1770	
	GU125T/A1-K	12.0	13.5		ET010N1830	
	GU140T/A1-K	14.01	15.1		ET01001590	
	GU160T/A1-K	15.0	17.4		ET01001580	
Duct Type	GU50P/A1-K	4.75	4.9	220V-240V ~50Hz	CF022N2330	
	GU71P/A1-K	7.0	7.4		CF022N2360	
	GU85P/A1-K	8.3	9.3		CF022N2400	
	GU100PH/A1-K	10.0	12.0		CF022N2320	
	GU125PH/A1-K	12.0	13.5		CF022N2380	
	GU140PH/A1-K	14.6	16.3		CF022N1950	
	GU160PH/A1-K	16.0	19.0		CF022N1920	

Model		Rated Cooling (kW)	Rated Heating (kW)	Power Supply	Finished Product Code	Appearance	
				(V,Ph,HZ)			
Duct Type(with pump)	GU50PS/A1-K	4.75	4.9	220V-240V ~50Hz	CF022N2340		
	GU71PS/A1-K	7.0	7.4		CF022N2350		
	GU85PS/A1-K	8.3	9.3		CF022N2410		
	GU100PHS/A1-K	10.0	12.0		CF022N2370		
	GU125PHS/A1-K	12.0	13.5		CF022N2390		
	GU140PHS/A1-K	14.6	16.3		CF022N1940		
	GU160PHS/A1-K	16.0	19.0		CF022N1930		
Floor Ceiling Type	GU50ZD/A1-K	5.0	5.2	220V-240V ~50Hz	ED020N2070		
	GU71ZD/A1-K	7.3	7.7		ED020N2080		
	GU85ZD/A1-K	8.6	9.3		ED020N2100		
	GU100ZD/A1-K	10.1	12.0		ED020N2090		
	GU125ZD/A1-K	12.0	13.2		ED020N2110		
	GU140ZD/A1-K	14.1	16.5		ED020N1880		
	GU160ZD/A1-K	15.8	19.1		ED020N1870		

**Note:**

The outdoor unit is generally suitable to any one of the three types of indoor units with no need of change (limited to cassette type, duct type and floor ceiling type).The above test results were all completed by using the power supply 230V,50Hz. Different power supplies may result in deviation.



## 1.2 Electrical Parameters

Model	Power Supply	Circuit Breaker Capacity	Min. Sectional Area of Power Cord
	V/Ph/Hz	A	mm <sup>2</sup>
GU50W/A1-K	220V-240V ~50Hz	16	1.5
GU71W/A1-K		20	2.5
GU85W/A1-K		25	2.5
GU100W/A1-M	380V-415V 3N ~50Hz	16	1.5
GU125W/A1-M		16	1.5
GU140W/A1-M		16	1.5
GU160W/A1-M		16	1.5

Model	Power Supply	Fuse Capacity	Circuit Breaker Capacity	Min. Sectional Area of Power Cord
	V/Ph/Hz	A	A	mm <sup>2</sup>
Indoor unit	220V-240V ~50Hz	3.15	6	1.0



### NOTICE:

- ① Fuse is located on the main board.
- ② Install a circuit breaker at every power terminal near the units (indoor and outdoor units) with at least 3mm contact gap. The units must be able to be plugged or unplugged.
- ③ Circuit breaker and power cord specifications listed in the above table are determined based on the maximum power input of the units.
- ④ Supply cords of parts of appliances for outdoor use shall not be lighter than polychloroprene sheathed flexible cord (code designation 60245 IEC57).
- ⑤ Specifications of circuit breaker are based on a working condition where the working temperature is 40°C. If working condition changes, please adjust the specifications according to national standards.
- ⑥ Adopt 2pc of 0.75mm<sup>2</sup> power cords to be the communication cords between indoor and outdoor units. The maximum length is 100m. Please select a proper length according to local conditions. Communication cords must not be twisted together. To be in compliance IOS5151, it is necessary to use 8 meters long wire.
- ⑦ The wire gauge of communication cord should not be less than 0.75mm<sup>2</sup>. It's recommended to use 0.75mm<sup>2</sup> power cords as the communication cords.
- ⑧ Calculation of the maximum permissible system impedance:
  - a) The following evaluation procedure shall be applied if the equipment emissions cannot meet the technical requirements of IEC 61000-3-3 and therefore the equipment cannot be declared compliant by the manufacturer in accordance with 6.2.1. In such a case the equipment shall only be connected to a supply having a system impedance lower than Zref.
  - b) To be in compliance with EN 61000-3-11, impedance value of power-supply system connected to product must be less than or equal to the allowable maximum value of |Zsys| in the following sheet:

Models	Max   Zsys   Unit: ohms
GU50W/A1-K	0.170

Models	Max   Zsys   Unit: ohms
GU71W/A1-K	0.090
GU85W/A1-K	0.071
GU100W/A1-M	0.416
GU125W/A1-M	0.142
GU140W/A1-M	0.173
GU160W/A1-M	0.193

- c) Before connecting the product to public power network, please consult your local power supply authority to ensure that the power network has met the above requirements. No requirement for the unlisted product's impedance value of power-supply system.

## 2. Control

### 2.1 Operation Mode

#### 2.1.1 Cooling Mode

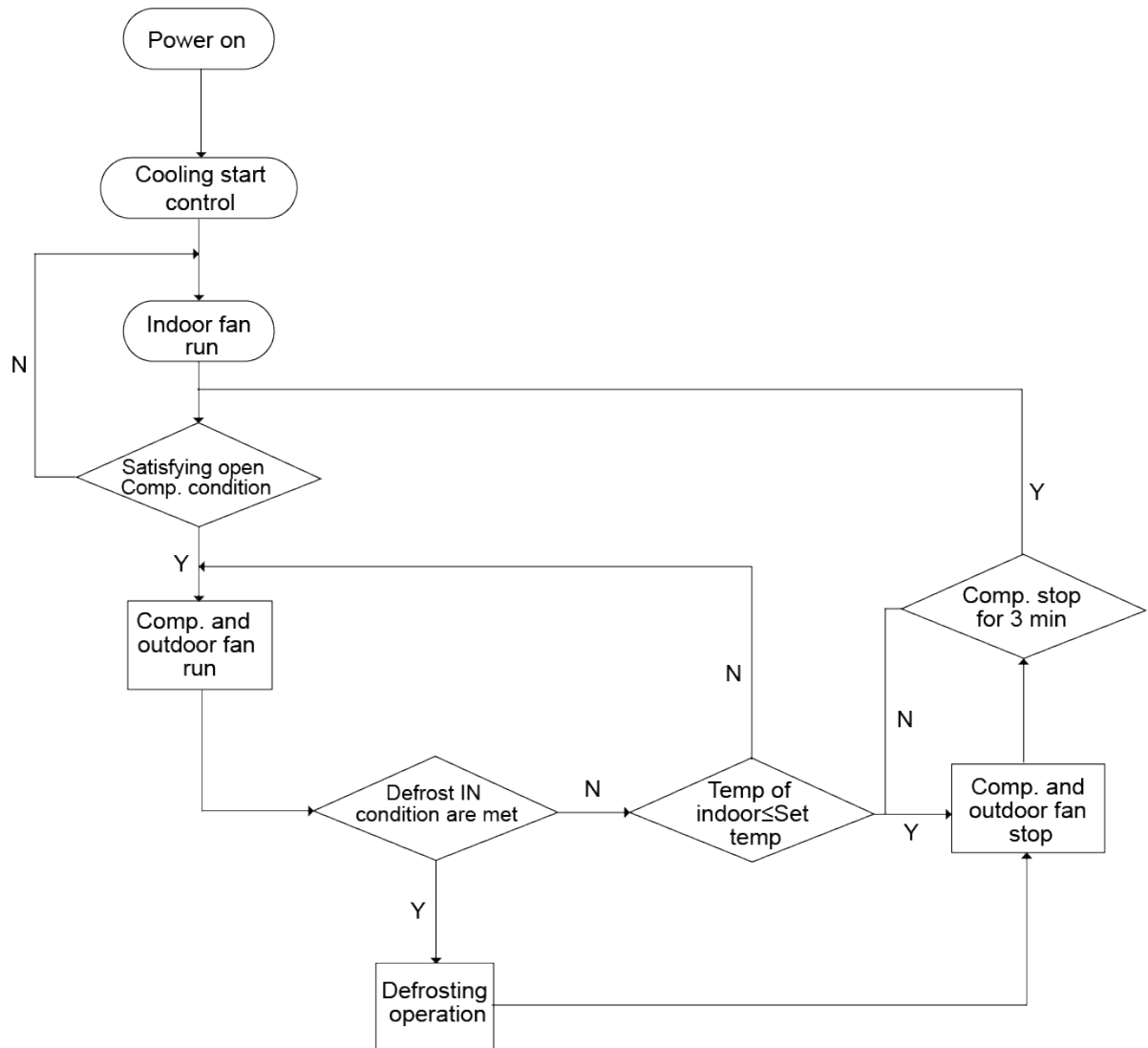

## 2.1.2 Heating Mode

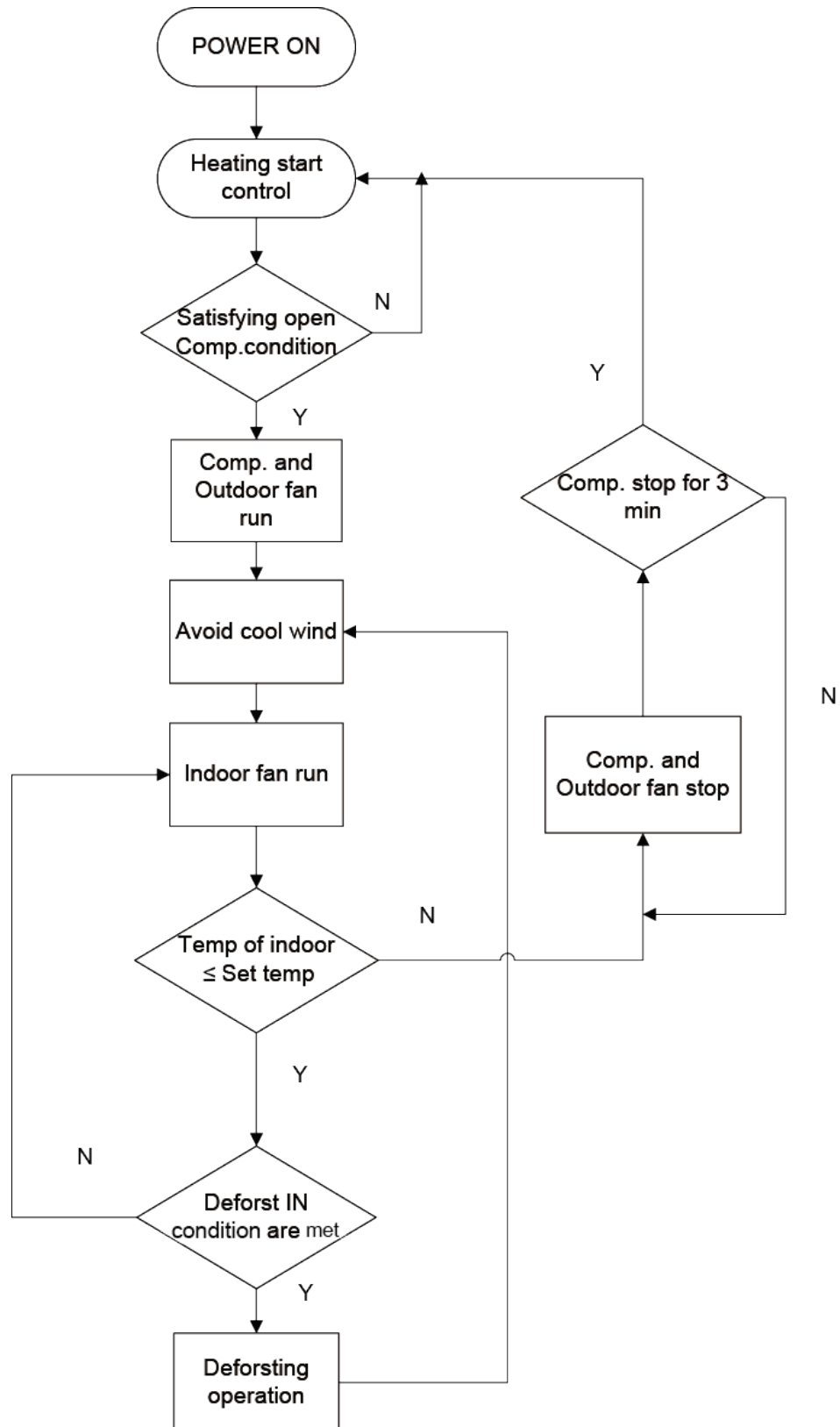

## 2.2 Control Mode

### 2.2.1 Based Control

#### 2.2.1.1 Compressor Control

When cooling mode is turned on, indoor fan will run for a while before the compressor starts. Under different modes, the compressor can only be stopped after running for some time (special cases excluded). This is to protect the compressor from frequent start or stop. Once the compressor is stopped, it must not be restarted right away. Please wait for a few minutes.

#### 2.2.1.2 EXV Control

When the unit is first started, the electronic expansion valve will reset control. During the process, the expansion valve will produce rattling sound. When cooling mode is turned on, the valve will be open at a certain step before the compressor starts. A few minutes later, the valve will start to control according to the target discharge Temperature preset by logic.

#### 2.2.1.3 Outdoor Fan Control

This series air conditioner has one type of outdoor units: one with a single fan. The outdoor fan can run at the highest level 6 and the lowest level 1. By controlling the speed of outdoor fan, the unit can achieve cooling at low temperature. In Fan mode, outdoor fan will not work.

### 2.2.2 Special Control

#### 2.2.2.1 Refrigerant Recovery Control(Pump Down)

Enabling method: Remote control and wired control both use the same enabling method. That is, within 5min after power is connected, start cooling mode (turn on the unit) and set temperature at 16°C, then press “+, -, +, -, +, -” (6 times of pressing) in 5s to enter the refrigerant recovery mode. If it is successfully enabled, the wired controller will display the corresponding code E3.

After the refrigerant recovery mode is enabled, if remote controller or wired controller sends a signal or the refrigerant recovery mode has been enabled for 10min, system will exit from refrigerant recovery. If outdoor unit is shut down because of malfunction, refrigerant recovery will be stopped immediately.

Please note that refrigerant recovery mode cannot be enabled under the following conditions:

- a) If temperature is shielded remotely, refrigerant recovery mode cannot be enabled. You need to first unlock the remote shield against temperature.
- b) If temperature is higher than 16 degrees under energy-saving mode, refrigerant recovery mode cannot be enabled. You need to first turn off the energy-saving mode.

#### 2.2.2.2 ODU Forced Operation Control

This control is used to quickly check whether the unit can operate normally after installation. Wired control has to be used to enable this control. For cassette type unit, you can enable the control through the light board.

Enabling method through the light board of cassette type unit: After the unit is installed and connected to power, press TEST button on the light board to enter forced operation mode. Short-press TEST button (less than

2s), cooling mode will be activated. Long-press TEST button (more than 2s), heating mode will be activated.

Enabling method through wired control:

Forced cooling: press the “▼” buttons continuously for 5s to enter the forced test mode; Forced heating: press the “▲” continuously for 5s to enter the forced test mode.

During test mode, press any button to quit the test mode.

Note:

Forced test mode can only be enabled when the unit is first turned on and not yet receives any remote control signal or button control signal.

## 2.2.3 Protection Control

### 2.2.3.1 High Pressure Protection Control

System will enable high pressure protection control if the high pressure switch is detected open. Under high pressure protection, system will be shut down and display error code E1.

When high pressure protection occurs for the first two time, system will restore operation if the high pressure switch is detected to be reclosed. When high pressure protection occurs for the third time in a certain time period, system will not restore operation. You need to manually turn off the unit and clear the error before restarting up the unit. (If high pressure protection occurs frequently, please send for professional personal to repair).

### 2.2.3.2 Low Pressure Protection Control

System will enable low pressure protection control if the low pressure switch is detected open. Under low pressure protection, system will be shut down and display error code E3. When low pressure protection occurs, system will restore operation if the low pressure switch is detected to be reclosed within 3s after shutdown. If low pressure protection occurs for 3 times in an hour, system will not restore operation automatically. You need to manually turn off the unit before restarting up the unit.

## 2.3 Functions

### 2.3.1 Setting of Filter Cleaning Reminder

When the unit is on, press Function button to switch to filter cleaning reminder. The icon  will blink and then the unit will enter the setting of filter cleaning reminder. Timer zone displays the set pollution level and you can press “▲” or “▼” button to adjust the level. Then press “SWING/ENTER” button to turn on this function.

When filter cleaning reminder is turned on, press Function button to switch to filter cleaning reminder. The icon  will blink. Then press “▲” or “▼” button to adjust the timer zone to “00”. Then press “SWING/ENTER” button to cancel this function.

When setting the filter cleaning reminder, timer zone will display 2 digits, of which the former indicates the pollution degree of operating place and the latter indicates the accumulated operating time of indoor unit. There are 4 types of situations:





- a) Cleaning Reminder is off (Timer zone shows “00”);
- b) Slight pollution: The former digit in timer zone shows “1” while the latter shows “0”, which indicates the accumulated operating time is 5500hr. Each time the latter digit increases 1, the accumulated operating time increases 500hr. When it reaches “9”, it means the accumulated operating time is 10000hr;

- c) Medium pollution: The former digit in timer zone shows “2” while the latter shows “0”, which indicates the accumulated operating time is 1400hr. Each time the latter digit increases 1, the accumulated operating time increases 400hr. When it reaches “9”, it means the accumulated operating time is 5000hr;
- d) Heavy pollution: The former digit in timer zone shows “3” while the latter shows “0”, which indicates the accumulated operating time is 100hr. Each time the latter digit increases 1, the accumulated operating time increases 100hr. When it reaches “9”, it means the accumulated operating time is 1000hr.

The detailed pollution level and the corresponding time are as shown in Table 2-4-1 below:

Pollution Level and Corresponding Time

Pollution Level	Accumulated Operating Time (hour)	Pollution Level	Accumulated Operating Time (hour)	Pollution Level	Accumulated Operating Time (hour)
10	5500	20	1400	30	100
11	6000	21	1800	31	200
12	6500	22	2200	32	300
13	7000	23	2600	33	400
14	7500	24	3000	34	500
15	8000	25	3400	35	600
16	8500	26	3800	36	700
17	9000	27	4200	37	800
18	9500	28	4600	38	900
19	10000	29	5000	39	1000

- (1) If filter cleaning reminder is turned on, the icon “” will be on.
- (2) If cleaning time is not reached, no matter the setting is changed or not, the accumulated operating time won't be recalculated when pressing “SWING/ENTER” button.
- (3) If cleaning time is reached, in unit on or off state, the icon “” will blink every 0.5s to remind the user. Press Function button to switch to the icon “” and press “▲” or “▼” button to adjust the level. Then press “SWING/ENTER” button, so the accumulated operating time won't be cleared (If the adjusted level is higher than the present accumulated operating time, the icon won't blink anymore; if the adjusted level is lower than the present accumulated operating time, the icon will go on blinking).
- (4) The only way to cancel filter cleaning reminder is to press Function button to switch to filter cleaning reminder. When the icon “” blinks, press “▲” or “▼” button to adjust timer zone to “00”. In this case, the accumulated operating time will be cleared.

## 2.3.2 Low Temperature Drying Function

Under dry mode and when set temperature is 16°C, continuously press “▼” button for twice and then the set temperature will be 12°C. In this case, the unit will enter low temperature drying function.

When low temperature drying function is turned on, press “▲” button or Mode button to exit low temperature drying function.

### 2.3.3 Lock Function

When the unit is normally turned on or turned off, pressing “▲” and “▼” buttons at the same time for 5s will turn on Lock function. LCD will display “”. Pressing “▲” and “▼” buttons at the same time for 5s to turn off this function.

When Lock function is turned on, any other buttons won't respond when pressing. This function can be memorized after power recovery.

### 2.3.4 Memory Function

Press Mode and “▲” buttons at the same time for 5s under off state of the unit to turn on or cancel memory function. If memory function is set, “” is displayed. If not, indoor unit is defaulted to be off after power recovery.

If memory function is set, indoor unit will resume original setting state after power recovery.

Note:

If power is cut off within 5s after memorized content is changed, the memorized content may be abnormal. Do not cut off power within 5s after memorized content is changed.

### 2.3.5 Access Control Function/ Human Sensitive Function

Access control function or human sensitive function can be selected (For more details, please refer to Debugging Function). These two functions can't be turned on at the same time.

When access control function is selected, the wired control will work when the room card is inserted and stop working when the room card is pulled out; when human sensitive function is selected, the wired control will work when it senses there is somebody in the room and stop working when it senses there is nobody in the room. When access control function senses the room card is not inserted or human sensitive function senses there is nobody in the room, wired control will display “”.

Note:

- ① In long-distance monitoring or centralized control, no matter the room card is inserted or not, the “ON/OFF” of unit can be controlled. If long-distance monitoring or centralized control information is received when the room card is not inserted, the icon “” is cleared. When the card is reinserted, access control function is judged to be turned on. If long-distance monitoring or centralized control information is received when the room card is inserted, it will keep the original status.
- ② The unit cannot be controlled by buttons when the card is not inserted.
- ③ When access control function and human sensitive function have been set at the same time, it is defaulted that access control function is valid and human sensitive function is invalid.

Note:

For this series, human sensitive function is invalid.

### 2.3.6 Switch between Fahrenheit and Centigrade

Under off state of the unit, press Mode and “▼” buttons at the same time for 5s to switch between Fahrenheit and Centigrade.



## 2.3.7 Enquiry of Ambient Temperature

Under off or on state of the unit, press "SWING/ENTER" for 5s to view the ambient temperature. In this case, timer zone displays ambient temperature type "01" or "02". Ambient temperature zone displays the corresponding temperature of that type. "01" stands for outdoor ambient temperature and "02" stands for indoor ambient temperature after compensation. Press Mode button to switch between "01" and "02". Pressing other buttons except Mode button or receiving remote control signal will exit enquiry state. If there is no operation within 20s, the unit will also exit enquiry state.

Note:

- ① If the unit is not connected to outdoor ambient temperature sensor, display of outdoor ambient temperature will be shielded after being energized for 12hrs.
- ② If there is malfunction of outdoor ambient temperature sensor, display of outdoor ambient temperature will be shielded after being energized for 12hrs.

## 2.3.8 Enquiry of Historical Malfunction

Under off or on state of the unit, continuously press Function and "▼" buttons for 5s to view historical malfunction.

In enquiry state, set temperature displaying zone displays "00". Press "▲" and "▼" buttons to view the 5 malfunctions happened recently. The timer displaying position displays the specific error code. The 5th displayed malfunction is the last malfunction.

## 2.3.9 Debugging Function

Under off state of the unit, press Function and Timer buttons at the same time for 5s to go to the debugging menu. Press Mode button to adjust the setting items and press "▲" or "▼" button to set the actual value.

### 2.3.9.1 Setting ambient temperature sensor (dual ambient temperature sensors function)

Under debugging state, press Mode button to adjust to "00" in temperature displaying zone. Timer zone displays setting state and press "▲" or "▼" button to adjust. There are 3 selections:

- (1) The ambient temperature at air return is set as indoor ambient temperature. (LCD displays 01)
- (2) The temperature at wired controller is set as indoor ambient temperature. (LCD displays 02)
- (3) Select the temperature sensor at air return in cooling, dry and fan mode; select the temperature sensor at wired controller in heating and auto mode. (LCD displays 03)

### 2.3.9.2 Selecting three speeds in high speed and three speeds in low speed of indoor fan motor

Under debugging state, press Mode button to adjust to "01" in temperature displaying zone. Timer zone displays setting state and press "▲" or "▼" button to adjust. There are 2 selections:

- (1) Three speeds in low speed. (LCD displays 01)
- (2) Three speeds in high speed. (LCD displays 02)

Three speeds in low speed include high, medium and low speeds; three speeds in high speed include super high, high and medium speed.

Note: For this series, this function is invalid.

### 2.3.9.3 Displaying setting of freeze protection error code

Under debugging state, press Mode button to adjust to "02" in temperature displaying zone. Timer zone displays setting state and press "▲" or "▼" button to adjust. There are 2 selections:

- (1) Displayed (LCD displays 01).
- (2) Not displayed (LCD displays 02).

It is defaulted to be not displayed for export unit and be displayed for domestic unit.

### 2.3.9.4 Setting refrigerant lacking protection function

Under debugging state, press Mode button to adjust to "04" in temperature displaying zone. Timer zone displays setting state and press "▲" or "▼" button to adjust. There are 2 selections:

- (1) With refrigerant lacking protection function. (LCD displays 01)
- (2) Without refrigerant lacking protection function. (LCD displays 02)

### 2.3.9.5 Selecting blowing residual heating of indoor unit

Under debugging state, press Mode button to adjust to "05" in temperature displaying zone. Timer zone displays setting state and press "▲" or "▼" button to adjust. There are 2 selections:

- (1) Mode 1 (LCD displays 00).
- (2) Mode 2 (LCD displays 01).

Note:

Blowing residual heating of indoor unit

Mode 1: Unit stops when reaching temperature point and indoor fan motor does not stop in cooling mode; after unit stops when reaching temperature point in heating mode, duct type unit and floor ceiling unit blow residual heat for 60s and then stop indoor unit, while cassette type unit always operates in low fan speed and blows residual heat for 60s when there is malfunction.

Mode 2: After unit stops when reaching temperature point, the indoor fan motor stops operation with a 10s-delay no matter in cooling mode or in heating mode.

### 2.3.9.6 Mode selecting of compressor electric heating belt

Under debugging state, press Mode button to adjust to "06" in temperature displaying zone. Timer zone displays setting state and press "▲" or "▼" button to adjust. There are 2 selections:

- (1) Mode 1 (LCD displays 00).
- (2) Mode 2 (LCD displays 01).

Note:

Mode 1: Compressor electric heating belt starts when outdoor ambient temperature is below 35°C and stops when outdoor ambient temperature is above 37°C. When outdoor ambient temperature is within 35°C ~ 37°C, the belt will keep its previous operation state.

Mode 2: Compressor electric heating belt starts when outdoor ambient temperature is below -2°C and stops when outdoor ambient temperature is above 0°C. When outdoor ambient temperature is within -2°C ~ 0°C, the belt will keep its previous operation state.

Note:

For this series, this function is invalid.

### 2.3.9.7 Selecting low-power consumption mode

Under debugging state, press Mode button to adjust to "07" in temperature displaying zone. Timer zone

displays setting state and press “▲” or “▼” button to adjust. There are 2 selections:

- (1) With low-power consumption mode. (LCD displays 00)
- (2) Without low-power consumption mode. (LCD displays 01)

Note:

For this series, this function is invalid.

### 2.3.9.8 Selecting door control function

Under debugging state, press Mode button to adjust to “08” in temperature displaying zone. Timer zone displays setting state and press “▲” or “▼” button to adjust. There are 2 selections:

- (1) Without door control function. (LCD displays 00)
- (2) With door control function. (LCD displays 01)

### 2.3.9.9 Selecting human sensitive function

Under debugging state, press Mode button to adjust to “09” in temperature displaying zone. Timer zone displays setting state and press “▲” or “▼” button to adjust. There are 2 selections:

- (1) Without human sensitive function. (LCD displays 00)
- (2) With human sensitive function. (LCD displays 00)

Note: For this series, this function is invalid.

### 2.3.9.10 Selecting long-distance monitoring or centralized controller

Under debugging state, press Mode button to adjust to “10” in temperature displaying zone. Timer zone displays setting state and press “▲” or “▼” button to adjust. There are 2 selections:

- (1) Centralized controller. (LCD displays 00)
- (2) Long-distance monitoring. (LCD displays 01)

### 2.3.9.11 Selecting compensation of temperature sensor at air return

Under debugging state, press Mode button to adjust to “12” in temperature displaying zone. Timer zone displays setting state and press “▲” or “▼” button to adjust. There are 16 selections:

- (1) Compensate 0°C (LCD displays 00)
- (2) Compensate 1°C (LCD displays 01)
- (3) Compensate 2°C (LCD displays 02)
- (4) Compensate 3°C (LCD displays 03)
- (5) Compensate 4°C (LCD displays 04)
- (6) Compensate 5°C (LCD displays 05)
- (7) Compensate 6°C (LCD displays 06)
- (8) Compensate 7°C (LCD displays 07)
- (9) Compensate 8°C (LCD displays 08)
- (10) Compensate 9°C (LCD displays 09)
- (11) Compensate 10°C (LCD displays 10)
- (12) Compensate 11°C (LCD displays 11)
- (13) Compensate 12°C (LCD displays 12)
- (14) Compensate 13°C (LCD displays 13)
- (15) Compensate 14°C (LCD displays 14)
- (16) Compensate 15°C (LCD displays 15)

Note:

Indoor ambient temperature compensation can be set through the wired control (E.g.: If 02 is selected, it indicates the compensation temperature is 2°C. If the indoor ambient temperature detected by the temperature sensor at air return is 29°C, the ambient temperature after compensation is  $29^{\circ}\text{C} - 2^{\circ}\text{C} = 27^{\circ}\text{C}$ ).

After finishing setting, press SWING/ENTER button to save and exit setting. After entering this interface, the system will exit this menu if there is no operation on the button within 20s. Normal off state interface will be displayed and present setting will not be saved.

### 2.3.9.12 Auto mode selection

Under debugging state, press Mode button to adjust to “16” in temperature displaying zone. Timer zone displays setting state and press “▲” or “▼” button to adjust. There are 2 selections:

- (1) Auto mode 1, the set temperature under auto mode can't be adjusted. (LCD displays 01)
- (2) Auto mode 2, the set temperature can be adjusted under auto mode. (LCD displays 02)

### 2.3.9.13 Defrost mode selection

Under debugging state, press Mode button to adjust to “17” in temperature displaying zone. Timer zone displays setting state and press “▲” or “▼” button to adjust. There are 2 selections:

- (1) Defrost mode 1 (LCD displays 01).
- (2) Defrost mode 2 (LCD displays 02).

Note:

For this series, this function is invalid.

### 2.3.9.14 Heat pump unit and cooling only unit selection

Under debugging state, press Mode button to adjust to “18” in temperature displaying zone. Timer zone displays setting state and press “▲” or “▼” button to adjust. There are 2 selections:

- (1) Heat pump type unit. (LCD displays 00)
- (2) Cooling only unit. (LCD displays 01)

After finishing setting, press “Swing/Enter” button to save and exit setting. After entering this interface, the system will exit this menu if there is no operation on the button within 20s. Normal off state interface will be displayed and present setting will not be saved.

## 2.3.10 Connect to Interface of Centralized Control

The indoor unit is with the interface of centralized controller. When centralized controller is connected, centralized control of unit can be realized even when the wired controller is not connected;

(1) Interface instruction:

1) The printing of interface on the indoor unit PCB is COM\_BMS, before connecting the centralized controller, a gateway model ME50-00/EG(M) is required, The following figure shows an example;

2) Electrical characteristic: none;

3) Working principle: centralized control the communication of indoor mainboard and realize the unit control;

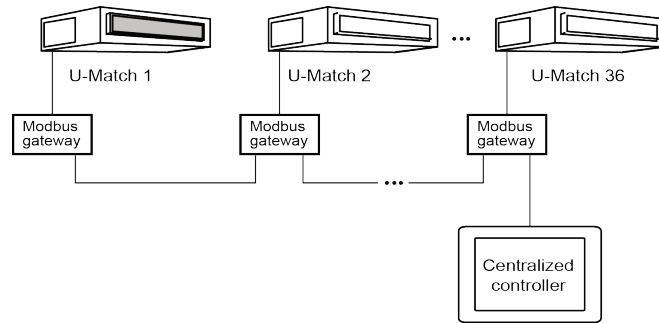

## (2) Function instructions:

In order to achieve this function, set the address mode and address through wired controller. Please refer to Point 3 for the setting method. The address mode is defaulted to be connecting to centralized controller mode and the defaulted address is 1;

When the centralized controller is connected, centralized control of the unit can be realized to control unit “ON/OFF”, operation mode, set fan speed/temperature and weekly timer.

## (3) Setting method:

### 1) Centralized control for up to 16 indoor units.

Firstly, set the address mode of wired controller into centralized controller address mode. The setting method is:

Under off state of the unit, press Function and Timer buttons at the same time for 5s to go to the debugging menu. Press Mode button to adjust to “10” in temperature displaying zone. Timer zone displays setting state and press “▲” or “▼” button to adjust. There are 2 selections:

- a. Centralized controller address mode (LCD displays 00).
- b. Long-distance control address mode (LCD displays 01).

Choose the first selection and then press “SWING/ENTER” button to save and exit setting. Now, the address of wired controller is set to match the address of centralized controller. The unit will memorize this setting status. The setting value will be memorized after power failure.

Address setting of each unit: when the address mode is set to be centralized controller address mode. The address setting value range is 01~16. The setting method is:

Under off state of the unit, press Function and Mode buttons at the same time for 5s to enter setting interface of wired controller address. LCD displays address sequence. Press “▲” or “▼” button to adjust the address sequence and then press “SWING/ENTER” button to confirm. The setting value will be memorized after power failure.

When the address is set, the wired controller can be removed and connect the centralized controller to the indoor mainboard. Then connect the required units to realize centralized control of these units;

Note:

- ① When centralized controller is to be connected, set the address mode into centralized controller address mode through wired controller. Long-distance control address mode cannot be set;
- ② The unit addresses in the same network must be different, otherwise, communication malfunction will occur and the unit cannot work normally;
- ③ When centralized controller is to be connected, the unit address range is 1-16. Only 16 sets of unit in maximum can be connected;
- ④ The code and model of wired controller is as below:

Name	Product Code	Remark
Centralized controller CE50-24/E	MC207025	Only 16 sets of unit in Maximum can be connected to this controller

2) Centralized control for up to 36 indoor units.

Firstly, set the address mode of wired controller into Long-distance control address mode. The setting method is:

Under off state of the unit, press Function and Timer buttons at the same time for 5s to go to the debugging menu. Press Mode button to adjust to "10" in temperature displaying zone. Timer zone displays setting state and press "▲" or "▼" button to adjust. There are 2 selections:

- a. Centralized controller address mode (LCD displays 00).
- b. Long-distance control address mode (LCD displays 01).

Choose the second selection and then press "Swing/Enter" button to save and exit setting. Now, the address of wired controller is set to match the address of centralized controller. The unit will memorize this setting status. The setting value will be memorized after power failure.

Address setting of each unit: when the address mode is set to be Long-distance control address mode. The address setting value range is 01~36. The setting method is:

Under off state of the unit, press Function and Mode buttons at the same time for 5s to enter setting interface of wired controller address. LCD displays address sequence. Press "▲" or "▼" button to adjust the address sequence and then press "Swing/Enter" button to confirm. The setting value will be memorized after power failure.

When the address is set, the wired controller can be removed and connect the centralized controller to the indoor mainboard. Then connect the required units to realize centralized control of these units;

Note:

- ① The unit addresses in the same network must be different, otherwise, communication malfunction will occur and the unit cannot work normally.
- ② When centralized controller is to be connected, the unit address range is 1-36. Only 36 sets of unit in maximum can be connected.
- ③ The code and model of wired controller is as below:

Name	Product Code	Remark
Centralized controller CE52-24/F(C)	MC207052	Only 36 sets of unit in maximum can be connected to this controller

# 3. Troubleshooting

## 3.1 Wiring Diagrams

Note:

The Wiring Diagrams may be changed due to the product improvement, please check the newest information with the Wiring Diagrams on unit.

### 3.1.1 Wiring Diagrams of ODUs

Model: GU50W/A1-K

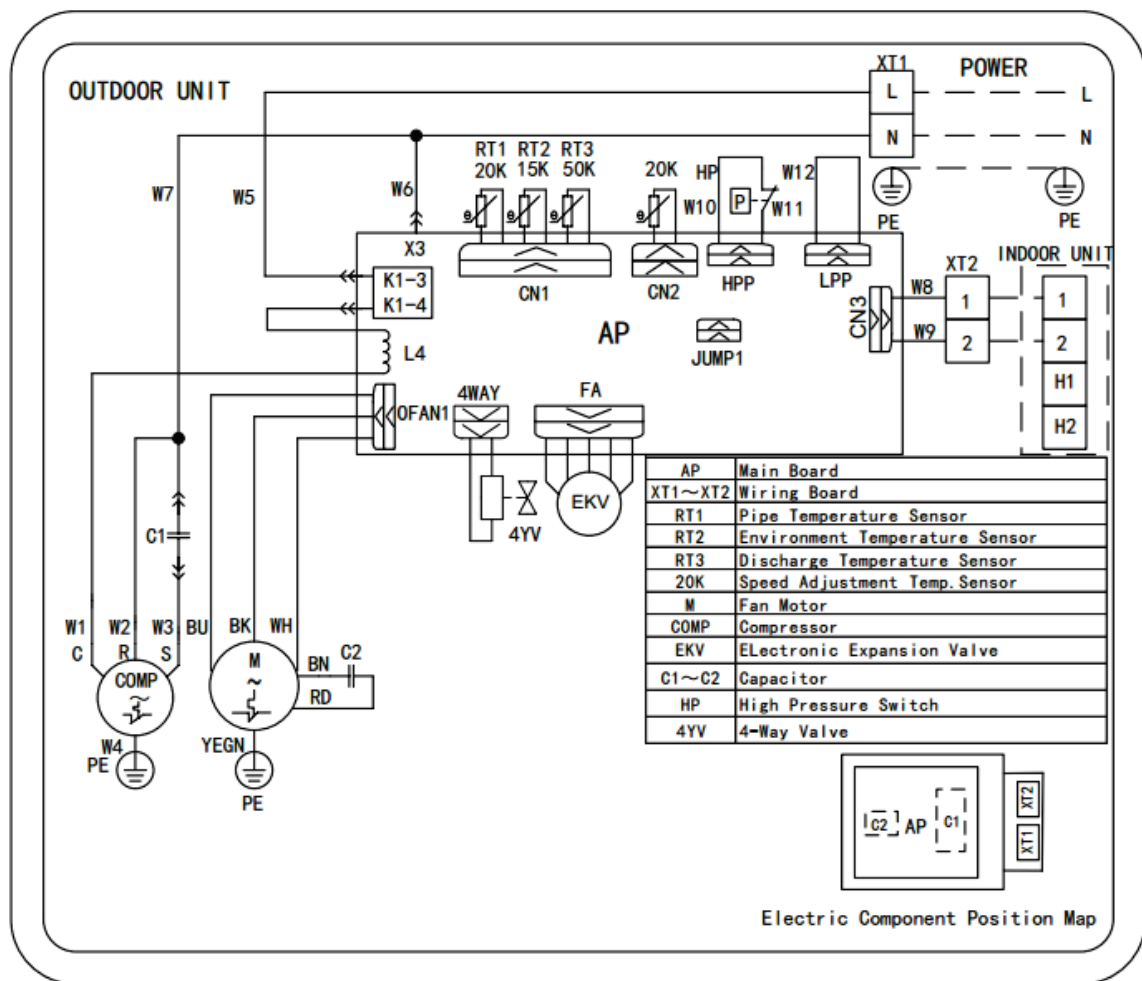

Model: GU71W/A1-K;GU85W/A1-K

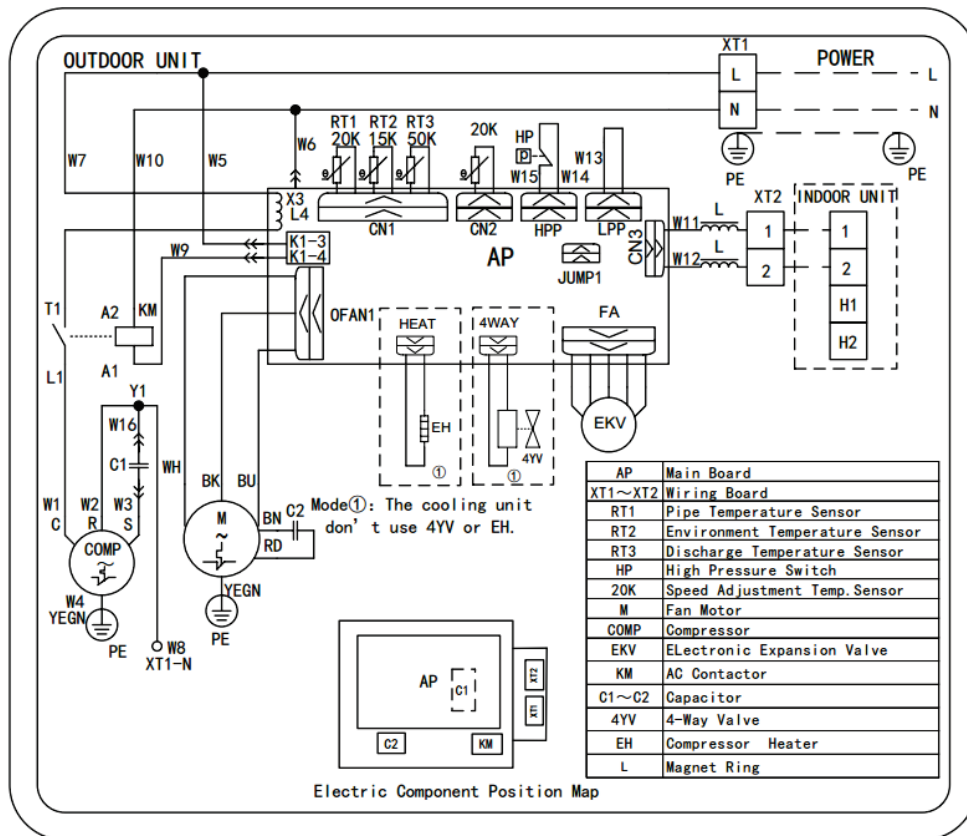

Model: GU100W/A1-M

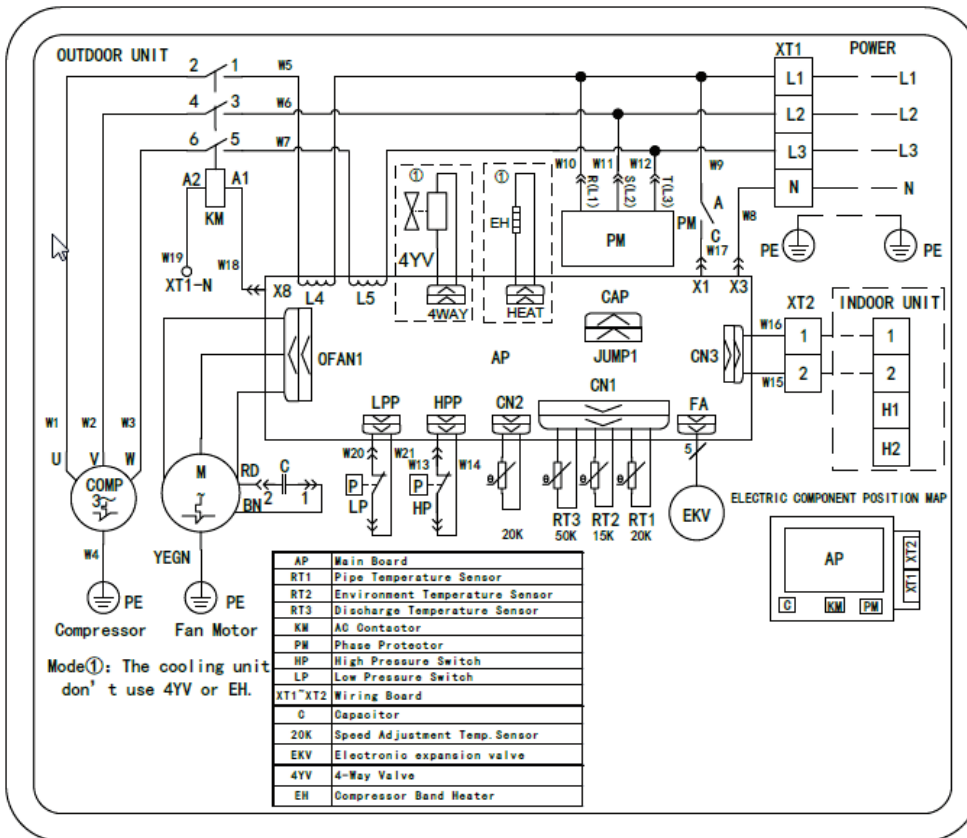



Model: GU125W/A1-M; GU140W/A1-M; GU160W/A1-M

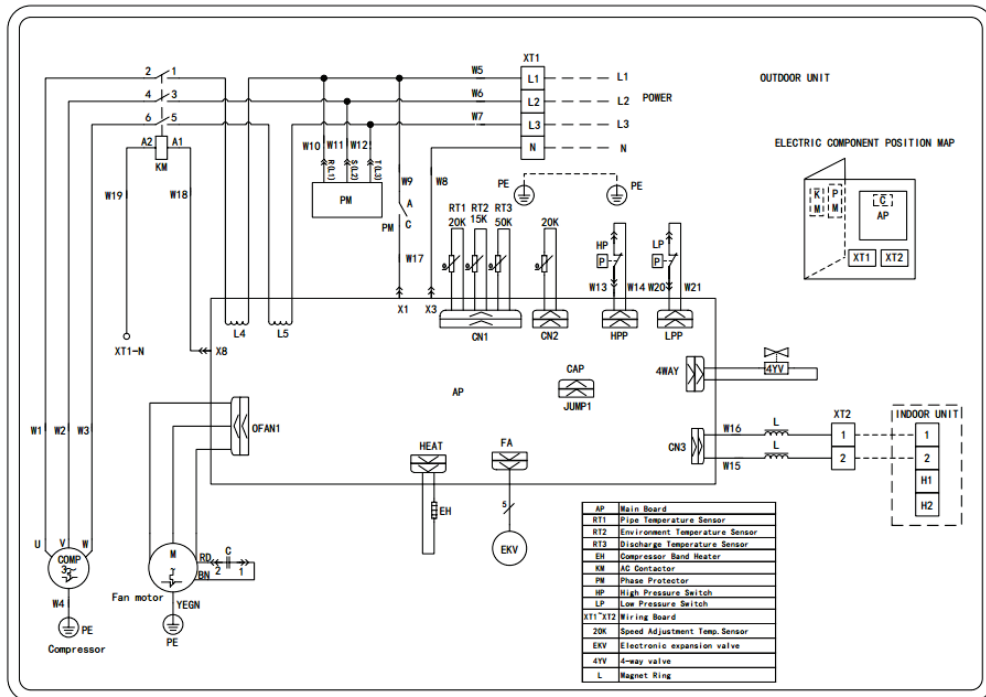

### 3.1.2 Wiring Diagrams of IDUs

#### Cassette Type

Model: GUD50T/A1-K

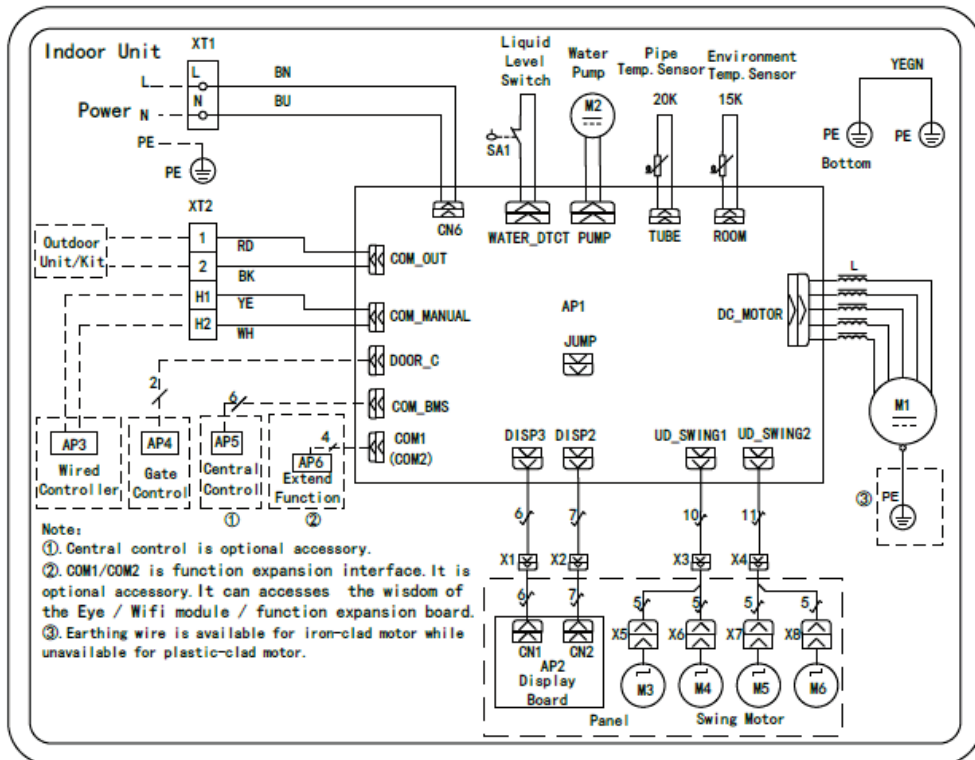

**Model:** GU71T/A1-K; GU85T/A1-K ;GU100T/A1-K;  
GU125T/A1-K; GU140T/A1-K; GU160T/A1-K

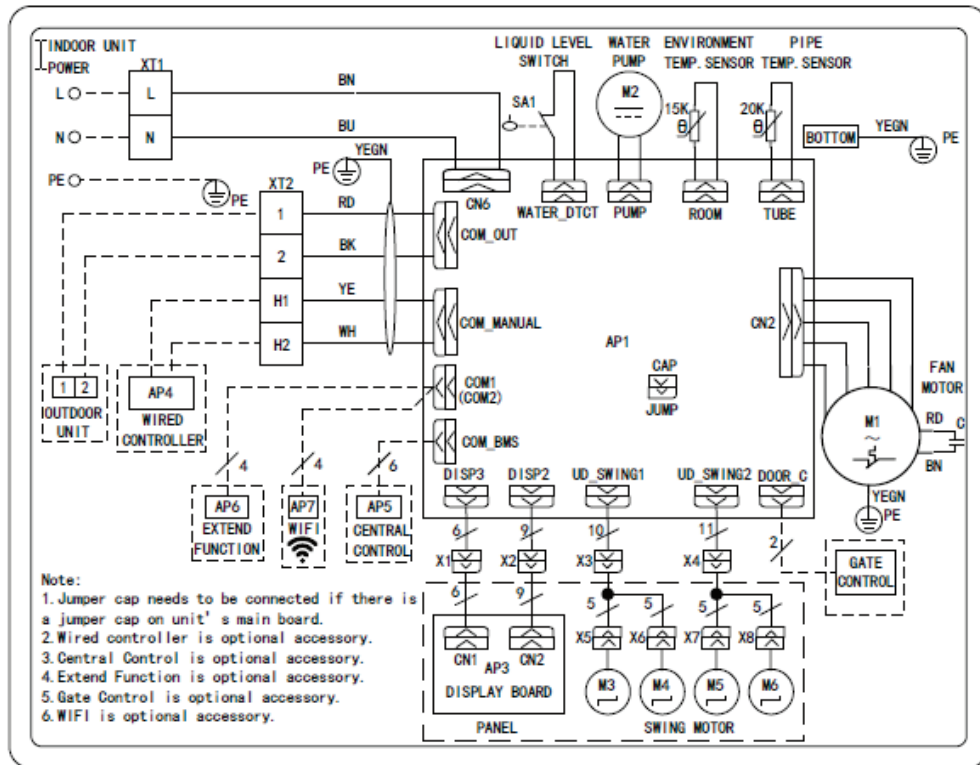

**Floor Ceiling Type:** GU50ZD/A1-K ; GU71ZD /A1-K; GU85ZD/A1-K ;GU100ZD/A1-K;  
GU125ZD/A1-K; GU140ZD /A1-K; GU160ZD/A1-K

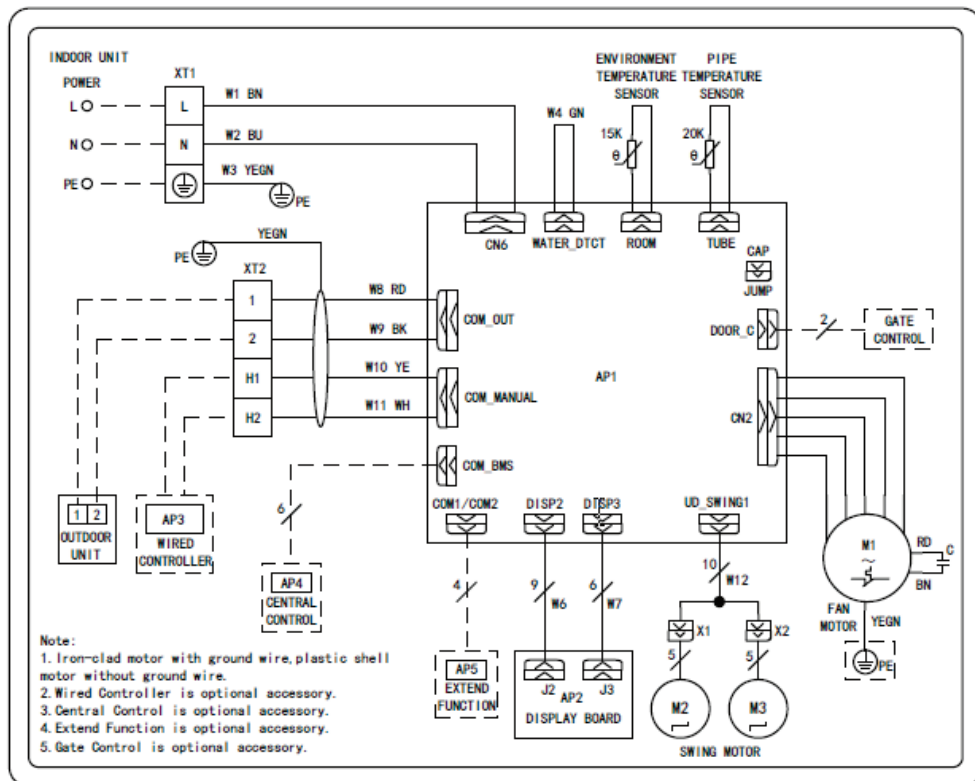

**Model:** GU50P/A1-K; GU71P/A1-K; GU85P/A1-K; GU100PH/A-K;  
 GU50PS/A1-K; GU71PS/A1-K; GU85PS/A1-K; GU100PHS/A-K

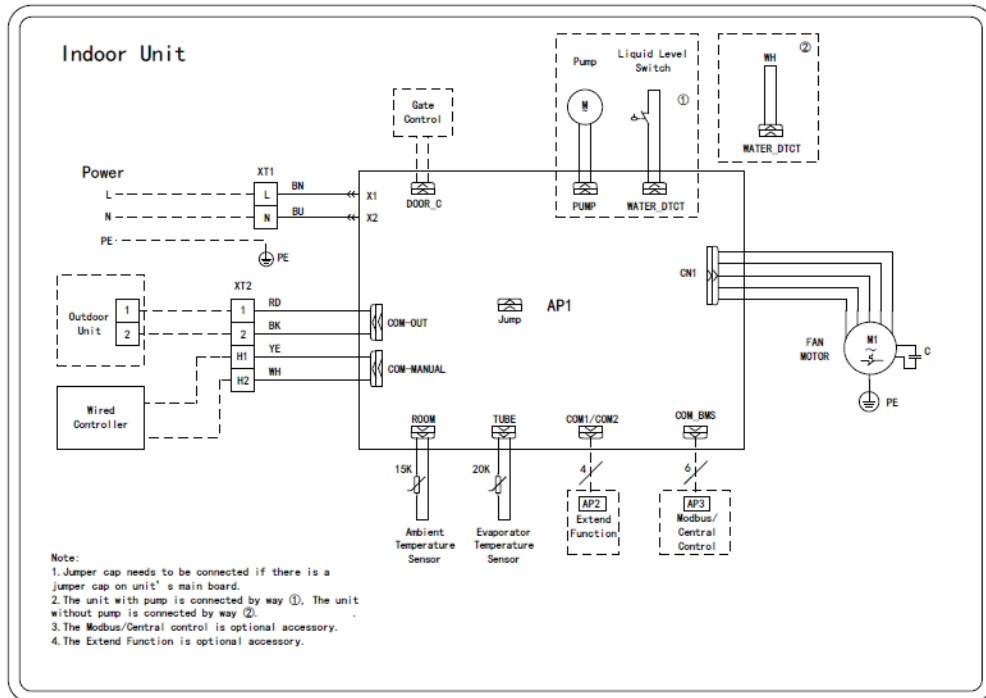

**Model:** GU125PH/A1-K; GU140PH/A1-K; GU160PH/A1-K;  
 GU125PHS/A1-K; GU140PHS/A1-K; GU160PHS/A1-K

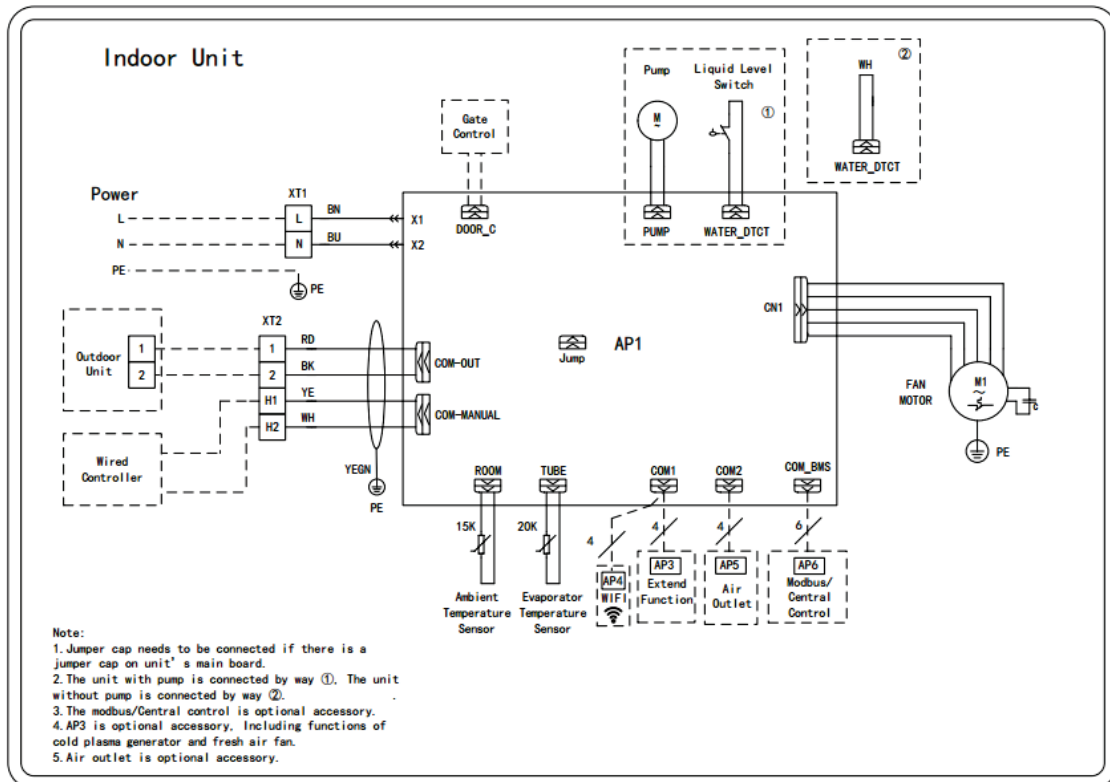

## 3.2 PCB Layout

Indoor Unit:

Cassette Type/Floor Ceiling Type:

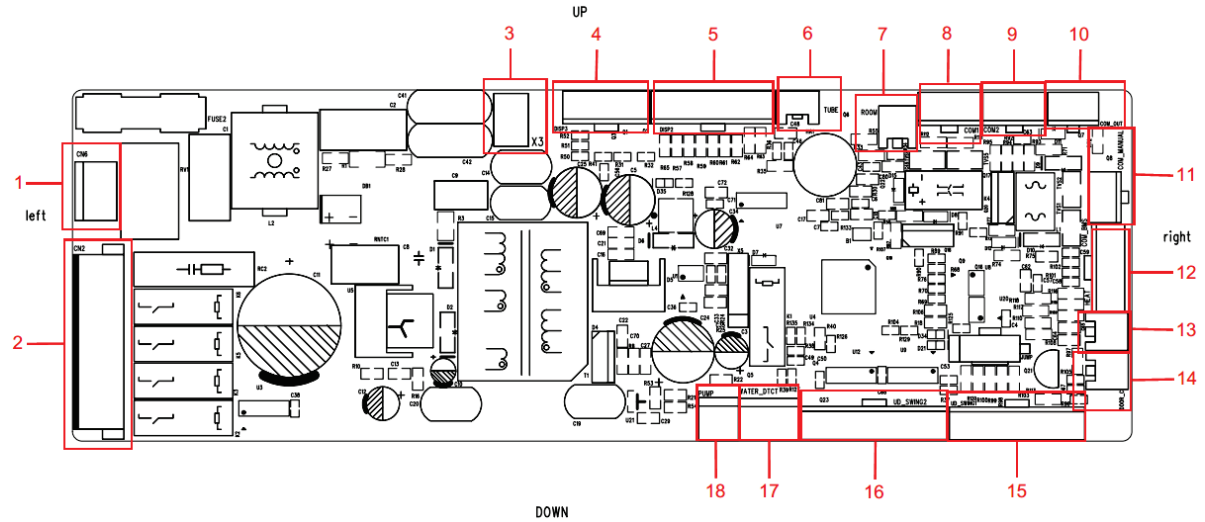

NO.	Printing	Interface	NO.	Printing	Interface
1	CN6	Power supply	2	CN2	motor Interface
3	X3	Ground wire	4	DISP3	Light board interface 3
5	DISP2	Light board interface 2	6	TUBE	Evaporator temperature sensor
7	ROOM	Ambient temperature	8	COM1	Accessories communication interface 1
9	COM2	Accessories Communication interface 2	10	COM_OUT	ODU communication interface
11	COM_MANAUL	Wired control communication interface	12	COM_BMS	MODBUS gateway interface
13	HEAT	Electric heating interface	14	DOOR_C	Access control interface
15	UD_SWING1	Vertical swing output 1	16	UD_SWING2	Vertical swing output 2
17	WATER_DTCT	Water level switch	18	PUMP	DC water pump

**Duct Type:**

**Models:** GU50P/A1-K; GU71P/A1-K; GU85P/A1-K; GU100PH/A1-K;  
 GU125PH/A1-K; GU140PH/A1-K; GU160PH/A1-K;  
 GU50PS/A1-K; GU71PS/A1-K; GU85PS/A1-K; GU100PHS/A1-K;  
 GU125PHS/A1-K; GU140PHS/A1-K; GU160PHS/A1-K

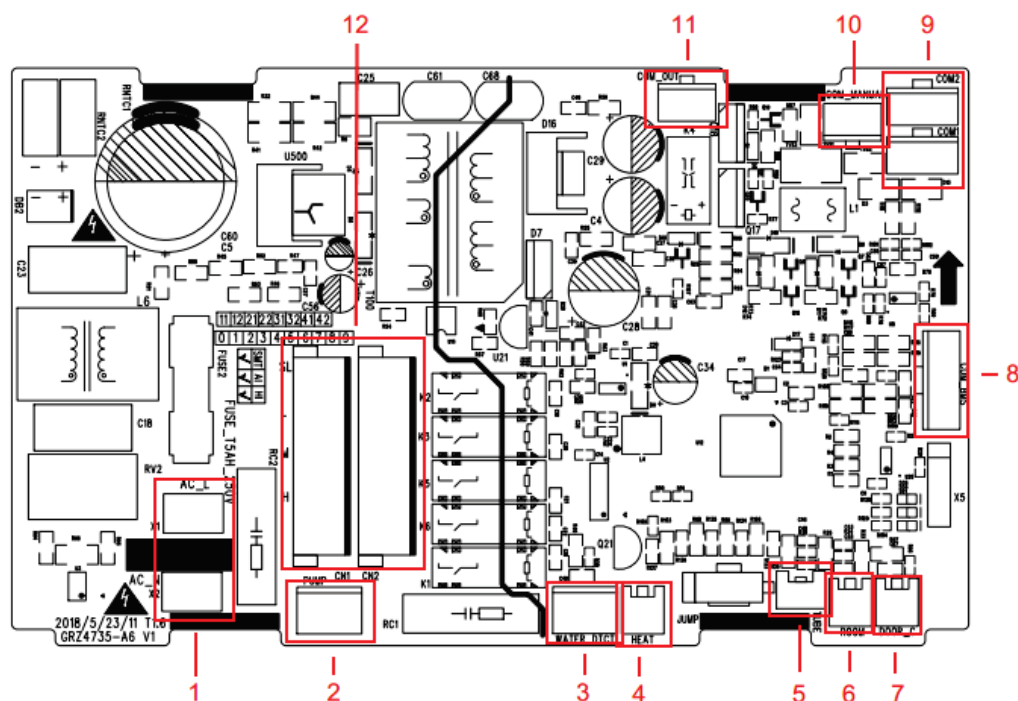

NO.	Printing	Interface	NO.	Printing	Interface
1	X1、X2	Power supply	2	PUMP	Water pump interface
3	WATER_DTCT	Water overflow detection	4	HEAT	Auxiliary heating interface (reserved)
5	TUBE	Indoor tube temperature sensor interface	6	ROOM	Room ambient temperature sensor interface
7	DOOR_C	Access control sensing interface	8	COM_BMS	MODBUS gateway interface
9	COM1、COM2	Accessories(Extended function board /WIFI)communication interface	10	COM-MANUAL	Wired control communication interface
11	COM-OUT	ODU communication interface	12	CN1、CN2	AC motor Interfaces

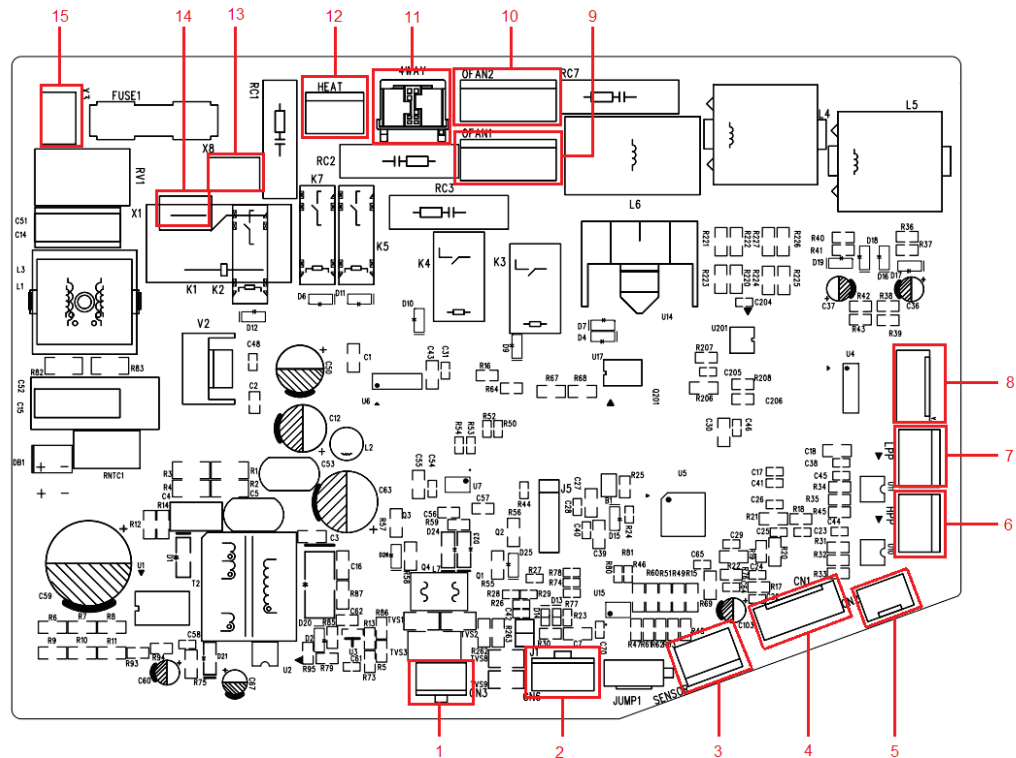
**Outdoor unit:****Mainboard**

NO.	Printing	Interface	NO.	Printing	Interface
1	CN3	IDU communication interface	2	CN6	GPRS communication interface
3	SENSOR	Pressure sensor interface (with CN2 two-for-one)	4	CN1	Outdoor tube temperature sensor interface; Outdoor ambient temperature sensor interface; Discharge temperature sensor interface
5	CN2	Low temperature cooling temperature sensing	6	HPP	System high pressure protection interface
7	LPP	System low pressure protection interface	8	FA	Electronic expansion valve
9	OFAN1	External drive DC fan	10	OFAN2	External drive DC fan
11	4WAY	4-way valve	12	HEAT	Electric heating interface
13	COMP	Compressor AC contactor interface	14	AC-L	Live wire input
15	AC-N	Neutral wire input			

### 3.3 Error Code

No.	Error code	Error
1	E1	Compressor high pressure protection.
2	E2	Indoor anti-freeze protection.
3	E3	Compressor low pressure protection, refrigerant lack protection and refrigerant collecting mode.
4	E4	Compressor air discharge high-temperature protection.
5	E6	Communication error.
6	E8	Indoor fan error.
7	E9	Water-full protection.
8	F0	Indoor ambient temperature sensor error.
9	F1	Evaporator temperature sensor error.
10	F2	Condenser temperature sensor error.
11	F3	Outdoor ambient temperature sensor error.
12	F4	Discharge temperature sensor error.
13	F5	Wired control temperature sensor error.
14	C5	IDU jumper cap error.
15	EE	IDU or ODU memory chip error.
16	H3	Compressor overload protection.
17	H4	Overload.
18	C4	ODU jumper cap error.
19	EL	Emergency Stop(Fire Alarm).

If malfunction occurs during operation, LCD temperature display zone will show the failure information. If several malfunctions occur at the same time, their corresponding error codes will be shown in turn. When malfunction occurs, please shut off the unit and send for professional personnel to repair. For example, E1 (as shown below) indicates high pressure protection.

