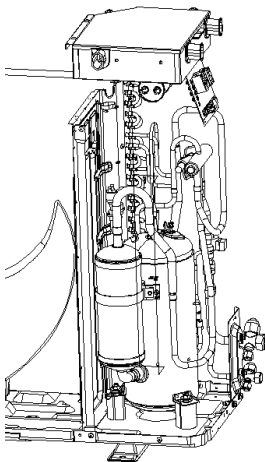
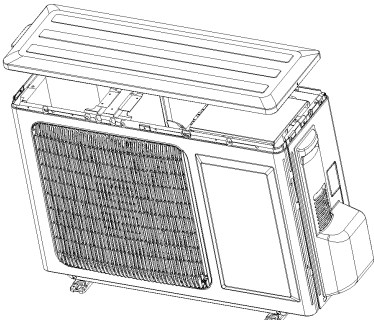
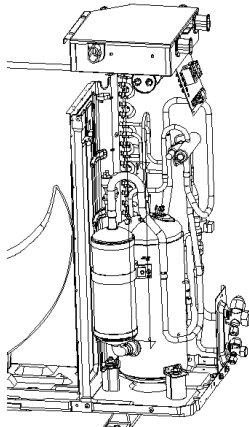
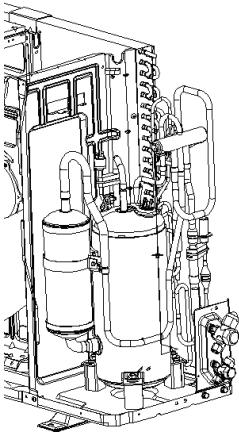
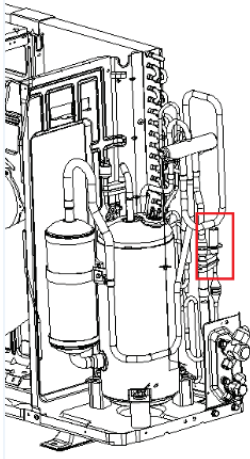
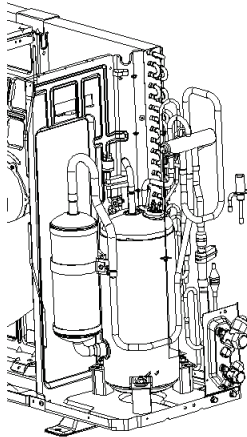
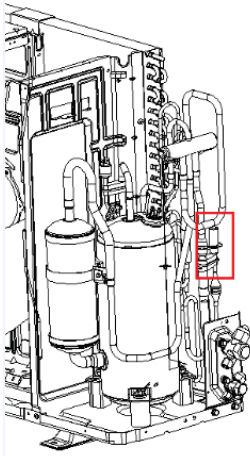
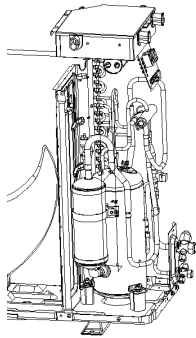
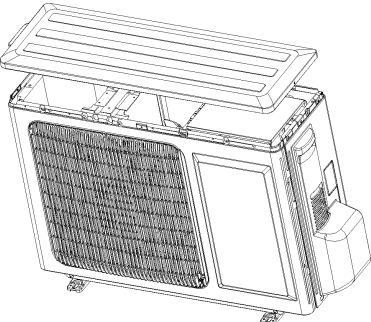

Removal of condenser		
Note: Before removing the condenser, make sure there is no refrigerant in the pipeline and power is cut off.		
Step	Picture	Work instruction
6. Secure the electric box and arrange the wires according to the requirement.		Put the electric box in place and tighten up the screws of electric box. Arrange and secure the wires as original.
7. Check and open the upper and side panels.		Check whether each component and connection wire is well connected. If everything is OK, place back the upper, left and right side panels.

**Model:** GU50W/A1-K; GU71W/A1-K; GU85W/A1-K

Removal of electronic expansion valve		
Note: Before removing the electronic expansion valve, make sure there is no refrigerant in the pipeline and power is cut off.		
Step	Picture	Work instruction
1. Loosen the wire clamp at the bottom of the electric box and the screws of electric box.		Remove the upper, lower and front panels. Loosen the wire clamp at the bottom of the electric box. Unscrew the screws of electric box.

Removal of electronic expansion valve		
Note: Before removing the electronic expansion valve, make sure there is no refrigerant in the pipeline and power is cut off.		
Step	Picture	Work instruction
2.Remove the electric box.		The connection wires inside and outside the electric box should be removed. When removing the electric box, be careful to protect the components.
3.Remove the electronic expansion valve.		Take off the coil of electronic expansion valve. Loosen the connection pipe of electronic expansion valve by welding. Then remove the connection pipe. Note: When welding the pipe, do not let the flame burn the other components.
4.Take out the electronic expansion valve.		Take out the electronic expansion valve

Removal of electronic expansion valve		
Note: Before removing the electronic expansion valve, make sure there is no refrigerant in the pipeline and power is cut off.		
Step	Picture	Work instruction
5. Install the new electronic expansion valve.		<p>Weld the connection pipe of electronic expansion valve.</p> <p>When welding the electronic expansion valve, the valve should be wrapped with wet cloth.</p> <p>Nitrogen welding: the pressure of nitrogen is <math>0.5 \pm 0.1 \text{ kgf/cm}^2</math> (relative pressure).</p> <p>Note: When welding the pipes, do not let the flame burn the other components.</p> <p>Install the coil of electronic expansion valve.</p>
6. Secure the electric box and arrange the wires as required.		<p>Put the electric box back in place and tighten up the screws.</p> <p>Arrange the wires as original.</p>
7. Check and install the panels.		<p>Check whether each component and connection wire is well connected.</p> <p>If everything is OK, install the upper, left and right panels. Tighten up the screws.</p>

**Model:** GU100W/A1-M

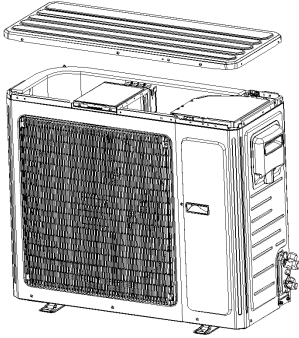
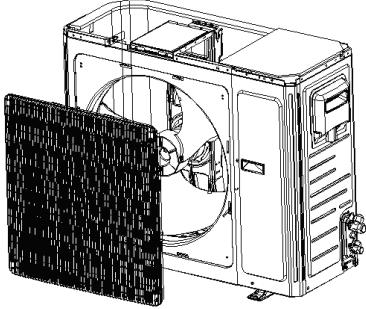
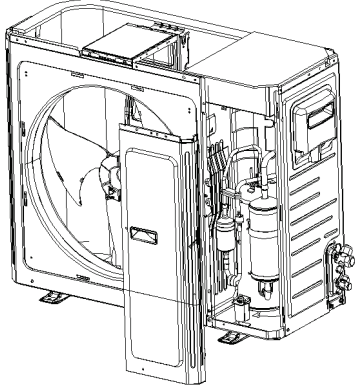
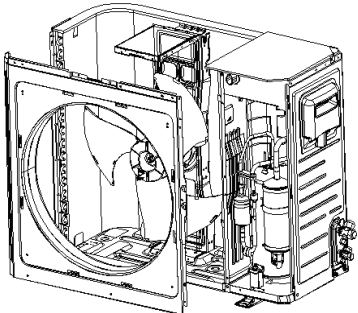
Removal of front panel		
Note: Before removing the front panel, make sure power is cut off.		
Step	Picture	Work instruction
1.Remove the upper cover plate.		Unscrew the screws of the upper cover plate with a screwdriver.
2.Remove the front grill.		Unscrew the screws of the front grill with a screwdriver.
3.Remove the front panel.		Unscrew the screws that connect the front panel to the middle insulating board and screws around the front panel.
		

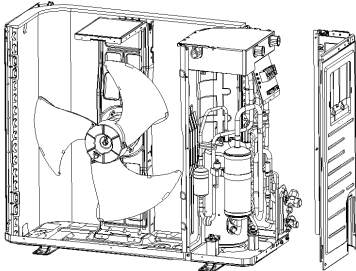
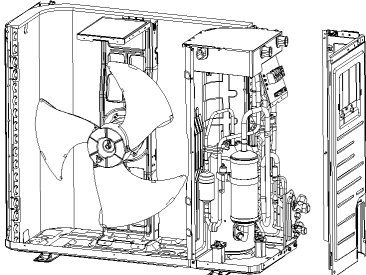
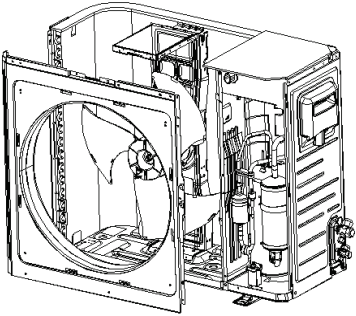
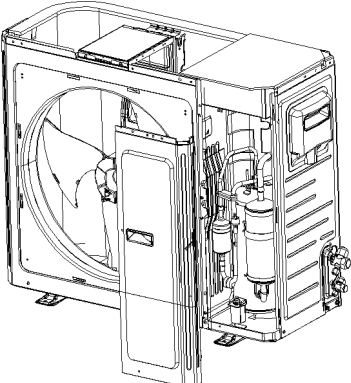
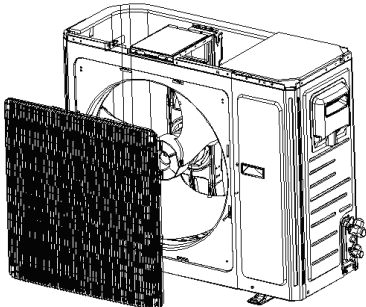
Removal of front panel		
Note: Before removing the front panel, make sure power is cut off.		
Step	Picture	Work instruction
4.Remove the right side plate.		Unscrew the screws that connect the right side plate to the electric box and the screws around the right side plate.
5.Install the right side plate		Screw up the screws around the right side plate. Be careful to handle well the clasps at the bottom of the right side plate.
6.Install the front side plate.		Tighten up the screws around the front side plate.
		
7.Install the grill.		Attach the grill back in place and tighten up the screws.

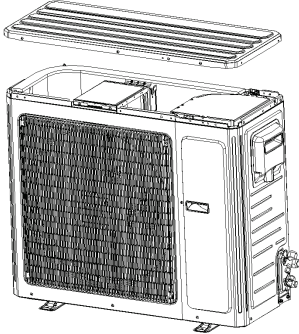
Removal of front panel		
Note: Before removing the front panel, make sure power is cut off.		
Step	Picture	Work instruction
8. Install the upper cover plate.		Tighten up the screws around the upper cover plate.

**Model:** GU100W/A1-M

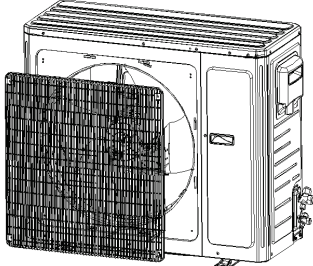
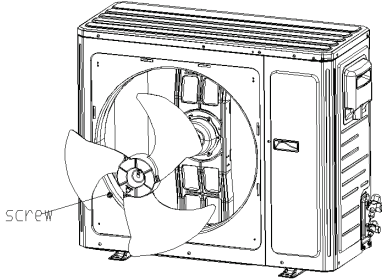
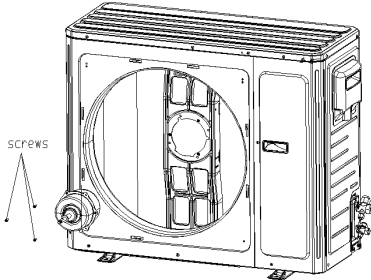
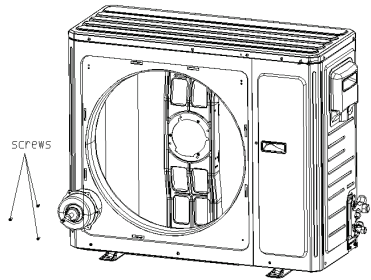
Removal of fan and motor		
Note: Before removing the fan, make sure power is cut off.		
Step	Picture	Work instruction
1. Remove the grill.		Use a screwdriver to unscrew the two screws on the upper left and lower right corners.
2. Remove the fan.		Use a wrench to remove the specialized nut and gasket of the fan. Note: Please keep the nut and gasket safe after removing them from the fan.
3. Remove motor.		Use a screwdriver to unscrew the bolt of motor. Note: Motor wire should be first removed from the electric box.
4. Install a new motor.		Replace with a new motor. Then tighten up the screw bolt.

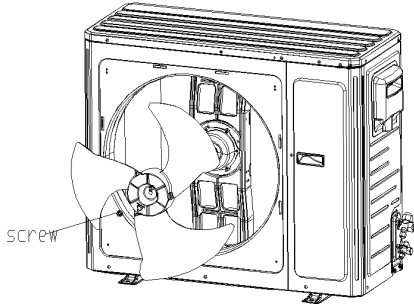
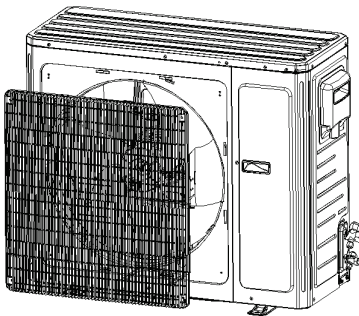
Removal of fan and motor		
Note: Before removing the fan, make sure power is cut off.		
Step	Picture	Work instruction
5. Install the fan.		<p>Install the fan in place. Put on the gasket and use a wrench to secure the screw nut.</p> <p>Note: After installing the fan, turn the fan by hand to see if it can run normally. If not, please check for the reason.</p>
6. Install the grill.		<p>After replacing the motor, use a screwdriver to tighten up the screw bolt that secures the motor.</p>

**Model:** GU100W/A1-M

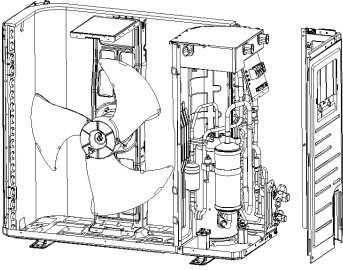
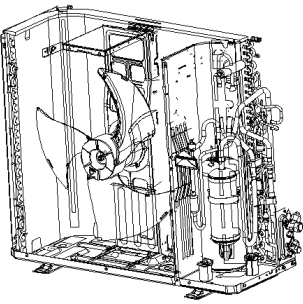
Removal of condenser		
Note: Before removing the condenser, make sure there is no refrigerant in the pipeline and power is cut off.		
Step	Picture	Work instruction
1. Remove the panels.		<p>Remove the upper, lower and front panels.</p>
2. Remove the electric box.		<p>Loosen the wire clamp at the bottom of the electric box.</p> <p>Unscrew the screws of electric box.</p> <p>The connection wires inside and outside the electric box should be removed.</p>

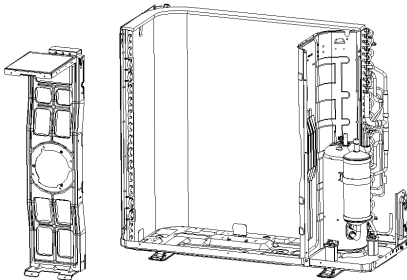
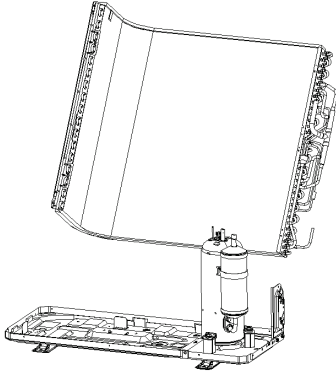
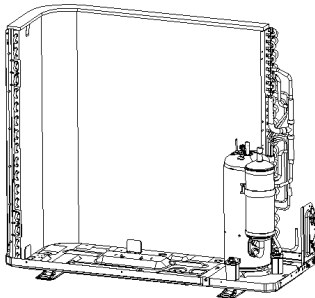
Removal of condenser		
Note: Before removing the condenser, make sure there is no refrigerant in the pipeline and power is cut off.		
Step	Picture	Work instruction
3.Remove motor support.		When removing the motor support, be careful to protect the components.
4.Remove the condenser.		Heat up the welding points of connection pipes through gas welding until the pipes break off. Loosen the securing screws of condenser support. Take off the plate type heat exchanger and the support as a whole. Note: When welding the pipes, do not let the flame burn the other components. The welding points of condenser are steel and copper welding points. Be sure to maintain the welding quality.
5.Install the new condenser.		Secure the screws of condenser and support. Then fix them together on the chassis. Install the condenser by referring to the positions of entering and leaving pipes. Weld the connection pipes. Nitrogen welding: the pressure of nitrogen is $0.5 \pm 0.1 \text{ kgf/cm}^2$ (relative pressure). Note: When welding the pipes, do not let the flame burn the other components.

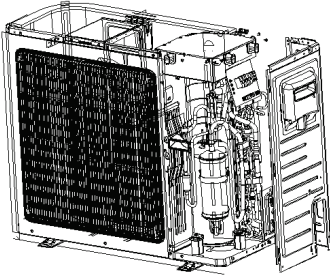
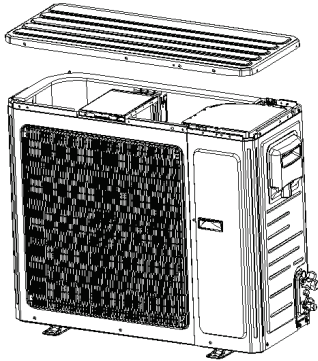

Removal of condenser		
Note: Before removing the condenser, make sure there is no refrigerant in the pipeline and power is cut off.		
Step	Picture	Work instruction
6. Secure the electric box and arrange the wires according to the requirement.		Put the electric box in place and tighten up the screws of electric box. Arrange and secure the wires as original.
7. Check and back the upper and side panels.		Check whether each component and connection wire is well connected. If everything is OK, place back the upper, left and right side panels.

**Model:** GU100W/A1-M

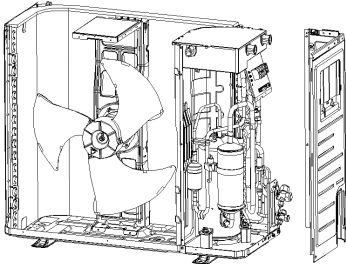
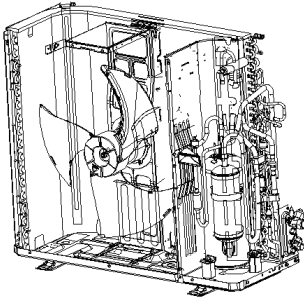
Removal of electronic expansion valve		
Note: Before removing the electronic expansion valve, make sure there is no refrigerant in the pipeline and power is cut off.		
Step	Picture	Work instruction
1. Loosen the wire clamp at the bottom of the electric box and the screws of electric box.		Remove the upper, lower and front panels. Loosen the wire clamp at the bottom of the electric box. Unscrew the screws of electric box.
2. Remove the electric box.		The connection wires inside and outside the electric box should be removed. When removing the electric box, be careful to protect the components.

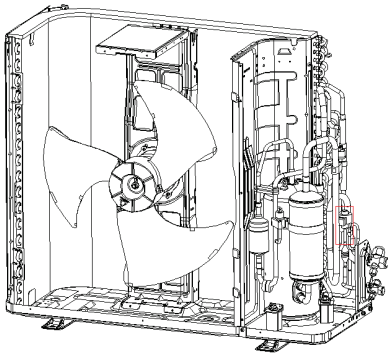
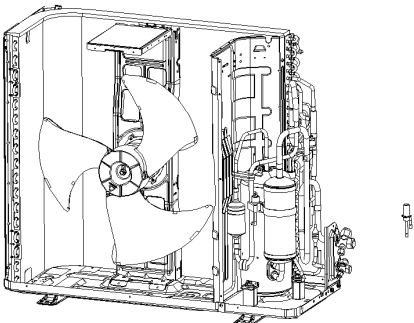
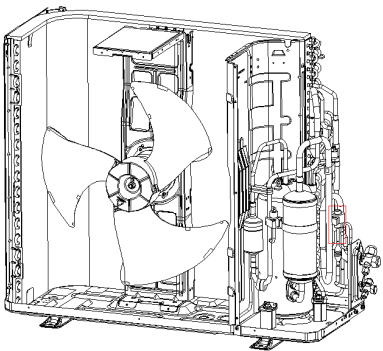
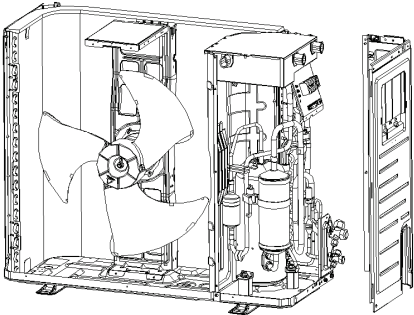
Removal of electronic expansion valve		
Note: Before removing the electronic expansion valve, make sure there is no refrigerant in the pipeline and power is cut off.		
Step	Picture	Work instruction
3.Remove the electronic expansion valve.		Take off the coil of electronic expansion valve. Loosen the connection pipe of electronic expansion valve by welding. Then remove the connection pipe. Note: When welding the pipe, do not let the flame burn the other components.
4.Take out the electronic expansion valve.		Take out the electronic expansion valve.
5.Install the new electronic expansion valve.		Weld the connection pipe of electronic expansion valve. When welding the electronic expansion valve, the valve should be wrapped with wet cloth. Nitrogen welding: the pressure of nitrogen is $0.5 \pm 0.1 \text{ kgf/cm}^2$ (relative pressure). Note: When welding the pipes, do not let the flame burn the other components. Install the coil of electronic expansion valve.
6.Secure the electric box and arrange the wires as required.		Put the electric box back in place and tighten up the screws. Arrange the wires as original.

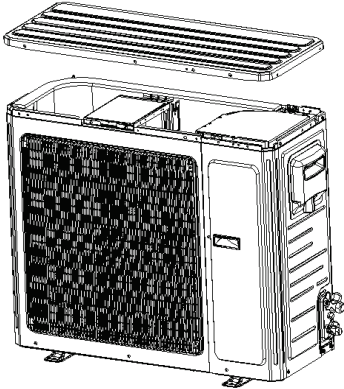
Removal of electronic expansion valve		
Note: Before removing the electronic expansion valve, make sure there is no refrigerant in the pipeline and power is cut off.		
Step	Picture	Work instruction
7. Check and install the panels.		<p>Check whether each component and connection wire is well connected.</p> <p>If everything is OK, install the upper, left and right panels.</p> <p>Tighten up the screws.</p>

**Model:** GU125W/A1-M;GU140W/A1-M;GU160W/A1-M

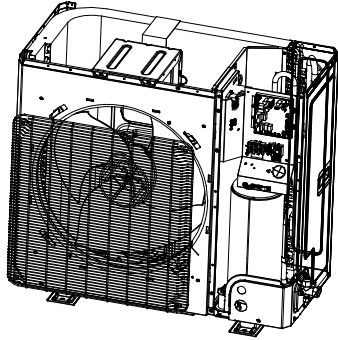
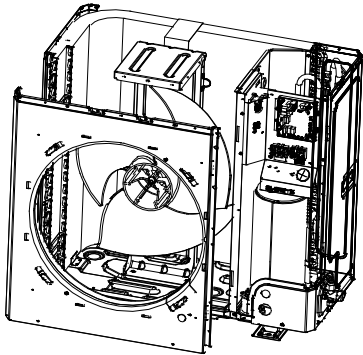
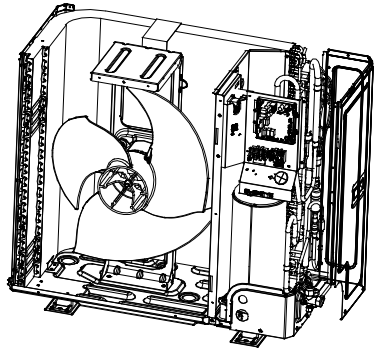
Removal of front panel		
Note: Before removing the front panel, make sure power is cut off.		
Step	Picture	Work instruction
1. Remove the upper cover plate.		<p>Unscrew the screws of the upper cover plate with a screwdriver.</p>
2. Remove the front side plate.		<p>Unscrew the screws of the upper and front side plate with a screwdriver.</p>
3. Remove the front grill.		<p>Unscrew the screws of the front grill with a screwdriver.</p>