



**U-MATCH SERIES A/A DC INVERTER AIR CONDITIONERS
SERVICE MANUAL**

**T1/R410A/50Hz
(GC201111-I)**

CONTENTS

PRODUCT	2
1 MODELS LIST	2
1.1 Outdoor Unit	2
1.2 Indoor Unit	3
2 NOMENCLATURE.....	4
3 PRODUCT DATA.....	5
3.1 Product Data of Indoor Unit	5
3.2 Operation Range	34
3.3 Electrical Data	34
4 PIPING DIAGRAM.....	35
CONTROL.....	37
1 OPERATION FLOWCHART.....	37
1.1 Cooling/Dry Operation.....	37
1.2 Heating Operation	38
2 WIRELESS REMOTE CONTROLLER.....	39
2.1 Operation View	39
3.2 Display View	41
3 WIRED REMOTE CONTROLLER.....	42
3.1 Operation View	42
3.2 Buttons.....	43
3.3 Installation of Wired Controller and Project Debugging	45
3.4 Error Display.....	46
3.5 Dimension	47
4 CENTRALIZED CONTROLLER.....	47
4.1 Centralized Controller-week timer	47
4.2 Smart Zone Controller	49
INSTALLATION.....	53
1 INDOOR UNIT INSTALLATION	53
1.1 Installation of Duct Type.....	53
1.2 Installation of Ceiling Type.....	60
1.3 Installation of Cassette Type.....	63
2 OUTDOOR UNIT INSTALLATION	70
2.1 Before Installation.....	70
2.2 Installation Site.....	71
2.3 Caution for Installation	71
2.4 Dimension Data	72
2.5 Installation Clearance Data	72
3 REFRIGERATION PIPING WORK.....	72
3.1 Refrigeration Piping Work Procedures	72
3.2 Caution in Connecting Pipes	75
3.3 Specification of Connection Pipe	76
4 ELECTRIC WIRING WORK	76
4.1 Wiring Principle.....	76
4.2 Electric Wiring Design	78

4.3 Specification of Power Supply Wire and Air Switch	82
MAINTENANCE	84
1 TROUBLE TABLE	84
2 FLOW CHART OF TROUBLESHOOTING	89
2.1 System Troubleshooting	89
2.2 Typical Troubleshooting for C series Outdoor Unit Drive (Inverter) by Single-phase Motor	95
2.3 Typical Troubleshooting for C series Outdoor Unit Drive (Inverter) by Single-phase Motor	99
2.4 Typical Troubleshooting Outdoor Unit Drive (Inverter) by Three-phase Motor.....	103
3 WIRING DIADRAM.....	110
3.1 Outdoor unit.....	110
3.2 Indoor unit	117
4 DISASSEMBLY AND ASSEMBLY PROCEDURE OF MAIN PARTS	121
4.1 Outdoor Unit	121
4.2.Indoor Unit	154
5 EXPLODED VIEWS AND SPARE PART LIST	166
5.1 Outdoor Unit	166
5.2 Indoor Unit	192



PRODUCT

PRODUCT

1 MODELS LIST

1.1 Outdoor Unit

Model Name	Product Code	Power Supply (V, Ph, Hz)	Appearance
GUHD09NK3CO	CF090W0260	220-240V~ 50Hz	
GUHD12NK3CO	CF090W0270	220-240V~ 50Hz	
GUHD09NK3C1O	CF090W0340	220-240V~ 50Hz	
GUHD12NK3C1O	CF090W0350	220-240V~ 50Hz	
GUHD18NK3CO	CF090W0281	220-240V~ 50Hz	
GUHD18NK3C1O	CF090W0500	220-240V~ 50Hz	
GUHD24NK3CO	CF090W0290	220-240V~ 50Hz	
GUHD24NK3C1O	CF090W0510	220-240V~ 50Hz	
GUHD30NK3CO	CF090W0330	220-240V~ 50Hz	
GUHD30NK3C1O	CF090W0520	220-240V~ 50Hz	
GUHD36NK3CO	CF090W0300 /CF090W0301	220-240V~ 50Hz	
GUHD36NK3C1O	CF090W0530	220-240V~ 50Hz	
GUHD42NK3CO	CF090W0310 /CF090W0311	220-240V~ 50Hz	
GUHD42NK3C1O	CF090W0540	220-240V~ 50Hz	
GUHD36NM3CO	CF090W0410 /CF090W0411	380-415V 3N~ 50Hz	
GUHD36NM3C1O	CF090W0560	380-415V 3N~ 50Hz	
GUHD42NM3CO	CF090W0420/CF090W0421	380-415V 3N~ 50Hz	
GUHD42NM3C1O	CF090W0570	380-415V 3N~ 50Hz	
GUHD48NK3CO	CF090W0320	220-240V~ 50Hz	
GUHD48NK3C1O	CF090W0550	220-240V~ 50Hz	
GUHD48NM3CO	CF090W0430	380-415V 3N~ 50Hz	
GUHD48NM3C1O	CF090W0580	380-415V 3N~ 50Hz	
GUHD60NM3CO	CF090W0440	380-415V 3N~ 50Hz	
GUHD60NM3C1O	CF090W0590	380-415V 3N~ 50Hz	

The unit GUHD*N*3C1O is capable for low ambient cooling.

1.2 Indoor Unit

Type	Model Name	Product Code	Nominal Capacity Cooling/ Heating (Btu/h)	Power Supply (V, Ph, Hz)	Appearance	
Duct Type	GFH09K3CI	CF060N0220	9212/10000	220-240V ~ 50Hz		
	GFH12K3CI	CF060N0231	12000/13000			
	GFH18K3CI	CF060N0240	18000/21000			
	GFH24K3CI	CF060N0250	24000/25500			
	GFH30K3CI	CF060N0260	28000/30000			
	GFH36K3CI	CF060N0270	34120/39238			
	GFH42K3CI	CF060N0290	37530/42650			
	GFH48K3CI	CF060N0280	48000/56300			
	GFH60K3CI	CF060N0300	58000/61400			
Cassette Type	GKH12K3CI	ET010N0170	11600/12600	220-240V ~ 50Hz		
	GKH18K3CI	ET010N0180	18000/21000			
	GKH24K3CI	ET010N0190	24000/27000			
	GKH30K3CI	ET010N0200	30000/32400			
	GKH36K3CI	ET010N0210	34120/37530			
	GKH42K3CI	ET010N0230	37530/42300			
Ceiling Type	GTH09K3CI	ED020N0171	10236/10236	220-240V ~ 50Hz		
	GTH12K3CI	ED020N0181	11600/13000			
	GTH18K3CI	ED020N0191	18000/21000			
	GTH24K3CI	ED020N0200	24000/27000			
	GTH30K3CI	ED020N0210	30000/32400			
	GTH36K3CI	ED020N0220	35826/39238			
	GTH42K3CI	ED020N0310	39238/42650			
		GTH48K3CI	ED020N0230	48000/56000	220-240V ~ 50Hz	
		GTH60K3CI	ED020N0440	54500/59700		

Note: 1 Ton = 12000 Btu/h = 3.517 kW

NOTES:

The universal outdoor units means that the customer can choose any of three kind of indoor unit to match the outdoor unit without any change with it.

2 NOMENCLATURE

G	U	H	D	09	N	K	3	C1	O
1	2	3	4	5	6	7	8	9	10

NO.	Description	Options
1	Gree Electric Appliances Inc	Capital Letter :G
2	Unit Type	U=U-Match Outdoor Unit
3	Product Type	C=Cool Only H=Heat Pump without Aux Electric Heaters
4	Compressor Power Supply Type Code	N=Constant Frequency D=DC Inverter A=AC Inverter
5	Nominal Cooling Capacity	Nominal Cooling Capacity =Number×1000Btu/h
6	Climate Type	N=Climate T1 Condition T= Climate T3 Condition
7	Power Supply Code	K= 220-240V~ 50Hz M=380-415V 3N~ 50Hz
8	Refrigerant	1 =R22; 2=R407C; 3=R410A
9	Design Code	Design Code: A, B, C, D..... Design Change Code=0 (default) 1,2,3.....
10	Unit Code	O=Outdoor unit

G	F	H	09	T	K	3	C	I
1	2	3	4	5	6	7	8	9

NO.	Description	Options
1	Gree Electric Appliances Inc	Capital Letter :G
2	Unit Type	F=Duct Type; K=Cassette Type; T= Floor-ceiling Type
3	Product Type	C=Cool Only H=Heat Pump without Aux Electric Heaters
4	Nominal Cooling Capacity	Nominal Cooling Capacity =Number×1000Btu/h
5	Climate Type	N=Climate T1 Condition T= Climate T3 Condition
6	Power Supply Code	K= 220-240V~ 50Hz M=380-415V 3N~ 50Hz
7	Refrigerant	1 =R22; 2=R407C; 3=R410A
8	Design Code	Design Code: A, B, C, D..... Design Change Code=0 (default) 1,2,3.....
9	Unit Code	I=indoor unite

3 PRODUCT DATA

3.1 Product Data of Indoor Unit

3.1.1 Duct Type

Model	Indoor unit		GFH09K3CI	GFH12K3CI
	Product Code		CF060N0220	CF060N0231
	Outdoor unit		GUHD09NK3CO	GUHD12NK3CO
	Product Code		CF090W0260	CF090W0270
Nominal Capacity	Cooling	kW	2.7	3.5
		Btu/h	9212	12000
	Heating	kW	2.9	3.8
		Btu/h	9895	13000
Power Input	Cooling	kW	0.83	1.077
	Heating	kW	0.803	0.974
EER/COP		W/W	3.25/3.61	3.25/3.9
Indoor Unit			GFH09K3CI	GFH12K3CI
Power Supply		—	220-240V~ 50Hz	
Heat Exchange		—	Cross Fin Coil	Cross Fin Coil
Fan	Drive	—	direct	direct
	Motor Output	kW	0.04×1	0.06×1
	Air Flow	m ³ /h	800	840
	Rated Ext. Static Pressure	Pa	25	25
Sound Pressure Level(H/M/L)		dB(A)	40/38/36	37/35/33
Air Filter		—	Standard washable synthetic	
Drain Piping		mm	Φ20×1.2	Φ30×1.5
Outline Dimensions (W×H×D)		mm	880×250×665	980×266×721
Net Weight		kg	26	34
Outdoor Unit			GUHD09NK3CO	GUHD12NK3CO
Power Supply		—	220-240V~ 50Hz	
Heat Exchange		—	Cross Fin Coil	
Compressor	Type	—	ROTARY	ROTARY
	Power Input	W	1070	1070
Refrigerant	Control	—	Capillary Tube	
	Charge	kg	1.2	1.35
Outline Dimensions (W×H×D)		mm	776×540×320	776×540×320
Net Weight		kg	28	30
Piping Connections	Liquid	Inch	Φ1/4	Φ1/4
	Gas	Inch	Φ3/8	Φ3/8
	Max. Length	m	20	20
	Max. Height	m	15	15

Continued 1

Model	Indoor unit		GFH09K3CI	GFH12K3CI
	Product Code		CF060N0220	CF060N0231
	Outdoor unit		GUHD09NK3C10	GUHD12NK3C10
	Product Code		CF090W0340	CF090W0350
Nominal Capacity	Cooling	kW	2.7	3.5
		Btu/h	9212	12000
	Heating	kW	2.9	3.8
		Btu/h	9895	13000
Power Input	Cooling	kW	0.83	1.077
	Heating	kW	0.803	0.974
EER/COP		W/W	3.25/3.61	3.25/3.90
Indoor Unit		GFH09K3CI	GFH12K3CI	
Power Supply		—	220-240V~ 50Hz	
Heat Exchange		—	Cross Fin Coil	Cross Fin Coil
Fan	Drive	—	direct	direct
	Motor Output	kW	0.04×1	0.06×1
	Air Flow	m ³ /h	800	840
	Rated Ext. Static Pressure	Pa	25	25
Sound Pressure Level(H/M/L)		dB(A)	40/38/36	37/35/33
Air Filter		—	Standard washable synthetic	
Drain Piping		mm	Φ20×1.2	Φ30×1.5
Outline Dimensions (W×H×D)		mm	880×250×665	980×266×721
Net Weight		kg	26	34
Outdoor Unit		GUHD09NK3C10	GUHD12NK3C10	
Power Supply		—	220-240V~ 50Hz	
Heat Exchange		—	Cross Fin Coil	
Compressor	Type	—	ROTARY	ROTARY
	Power Input	W	1070	1070
Refrigerant	Control	—	Capillary Tube	
	Charge	kg	1.2	1.25
Outline Dimensions (W×H×D)		mm	848×540×320	848×540×320
Net Weight		kg	33	33
Piping Connections	Liquid	Inch	Φ1/4	Φ1/4
	Gas	Inch	Φ3/8	Φ3/8
	Max. Length	m	20	20
	Max. Height	m	15	15

Continued 2

Model	Indoor unit		GFH18K3CI	GFH24K3CI	GFH30K3CI
	Product Code		CF060N0240	CF090W0290	CF060N0260
	Outdoor unit		GUHD18NK3CO	GUHD24NK3CO	GUHD30NK3CO
	Product Code		CF090W0281	CF060N0250	CF090W0330
Nominal Capacity	Cooling	kW	5.3	7	8.2
		Btu/h	18000	24000	28000
	Heating	kW	6.15	7.5	8.8
		Btu/h	21000	25500	30000
Power Input	Cooling	kW	1.65	2.18	2.55
	Heating	kW	1.7	2.07	2.43
EER/COP		W/W	3.21/3.62	3.21/3.62	3.22/3.62
Indoor Unit			GFH18K3CI	GFH24K3CI	GFH30K3CI
Power Supply		—	220-240V~ 50Hz		
Heat Exchange		—	Cross Fin Coil	Cross Fin Coil	Cross Fin Coil
Fan	Drive	—	direct	direct	direct
	Motor Output	kW	0.07×1	0.15×1	0.15×1
	Air Flow	m ³ /h	1000/800/600	1600/1400/1200	1500/1300/1100
	Rated Ext. Static Pressure	Pa	25	25	37
Sound Pressure Level(H/M/L)		dB(A)	42/38/36	47/44/42	47/44/42
Air Filter		—	Standard washable synthetic		
Drain Piping		mm	Φ30×1.5	Φ20×1.2	Φ20×1.2
Outline Dimensions (W×H×D)		mm	980×266×721	1270×268×530	1270×268×530
Net Weight		kg	34	37	36
Outdoor Unit			GUHD18NK3CO	GUHD24NK3CO	GUHD30NK3CO
Power Supply		—	220-240V~ 50Hz		
Heat Exchange		—	Cross Fin Coil		
Compressor	Type	—	ROTARY	ROTARY	ROTARY
	Power Input	W	1630	2200	2200
Refrigerant	Control	—	Electronic Expansion Valve		
	Charge	kg	1.4	2.4	2.6
Outline Dimensions (W×H×D)		mm	955×700×396	980×790×427	980×790×427
			1029× 750×458	1083×855×488	1083×855×488
Net Weight		kg	48	65	68
Piping Connections	Liquid	Inch	Φ1/4	Φ3/8	Φ3/8
	Gas	Inch	Φ1/2	Φ5/8	Φ5/8
	Max. Length	m	20	30	30
	Max. Height	m	15	15	15

Continued 3

Model	Indoor unit		GFH18K3CI	GFH24K3CI	GFH30K3CI
	Product Code		CF060N0240	CF060N0250	CF060N0260
	Outdoor unit		GUHD18NK3C1O	GUHD24NK3C1O	GUHD30NK3C1O
	Product Code		CF090W0500	CF090W0510	CF090W0520
Nominal Capacity	Cooling	kW	5.3	7	8.2
		Btu/h	18000	24000	28000
	Heating	kW	6.15	7.5	8.8
		Btu/h	21000	25500	30000
Power Input	Cooling	kW	1.65	2.18	2.55
	Heating	kW	1.70	2.07	2.43
EER/COP		W/W	3.21/3.62	3.21/3.62	3.22/3.62
Indoor Unit			GFH18K3CI	GFH24K3CI	GFH30K3CI
Power Supply		—	220-240V~ 50Hz		
Heat Exchange		—	Cross Fin Coil	Cross Fin Coil	Cross Fin Coil
Fan	Drive	—	direct	direct	direct
	Motor Output	kW	0.07×1	0.15×1	0.15×1
	Air Flow	m ³ /h	1000/800/600	1600/1400/1200	1500/1300/1100
	Rated Ext. Static Pressure	Pa	25	25	37
Sound Pressure Level(H/M/L)		dB(A)	42/38/36	47/44/42	47/44/42
Air Filter		—	Standard washable synthetic		
Drain Piping		mm	Φ30×1.5	Φ20×1.2	Φ20×1.2
Outline Dimensions (W×H×D)		mm	980×266×721	1270×268×530	1270×268×530
Net Weight		kg	34	37	36
Outdoor Unit			GUHD18NK3C1O	GUHD24NK3C1O	GUHD30NK3C1O
Power Supply		—	220-240V~ 50Hz		
Heat Exchange		—	Cross Fin Coil		
Compressor	Type	—	ROTARY	ROTARY	ROTARY
	Power Input	W	1630	2200	2200
Refrigerant	Control	—	Electronic Expansion Valve		
	Charge	kg	1.4	2.4	2.6
Outline Dimensions (W×H×D)		mm	955×700×396	980×790×427	980×790×427
Net Weight		kg	46	65	68
Piping Connections	Liquid	Inch	Φ1/4	Φ3/8	Φ3/8
	Gas	Inch	Φ1/2	Φ5/8	Φ5/8
	Max. Length	m	20	30	30
	Max. Height	m	15	15	15

Continued 4

Model	Indoor unit		GFH36K3CI	GFH42K3CI	GFH36K3CI
	Product Code		CF060N0270	CF060N0290	CF060N0270
	Outdoor unit		GUHD36NK3CO	GUHD42NK3CO	GUHD36NM3CO
	Product Code		CF090W0301	CF090W0311	CF090W0411
Nominal Capacity	Cooling	kW	10.0	11.0	10.3
		Btu/h	34120	37530	35140
	Heating	kW	11.5	12.5	11.5
		Btu/h	39238	42650	39238
Power Input	Cooling	kW	3.115	3.42	3.2
	Heating	kW	3.18	3.46	3.18
EER/COP		W/W	3.21/3.61	3.21/3.61	3.21/3.61
Indoor Unit			GFH36K3CI	GFH42K3CI	GFH36K3CI
Power Supply		—	220-240V~ 50Hz		
Heat Exchange		—	Cross Fin Coil	Cross Fin Coil	Cross Fin Coil
Fan	Drive	—	direct	direct	direct
	Motor Output	kW	0.5×1	0.5×1	0.5×1
	Air Flow	m ³ /h	2300/2110/1850	2300/2110/1850	2300/2110/1850
	Rated Ext. Static Pressure	Pa	37	37	37
Sound Pressure Level(H/M/L)		dB(A)	53/50/46	53/50/46	53/50/46
Air Filter		—	Standard washable synthetic		
Drain Piping		mm	Φ20×1.2	Φ20×1.2	Φ20×1.2
Outline Dimensions (W×H×D)		mm	1226×290×775	1226×290×775	1226×290×775
Net Weight		kg	57	57	57
Outdoor Unit			GUHD36NK3CO	GUHD42NK3CO	GUHD36NM3CO
Power Supply		—	220-240V~ 50Hz		380-415V 3N~ 50Hz
Heat Exchange		—	Cross Fin Coil		Cross Fin Coil
Compressor	Type	—	ROTARY		ROTARY
	Power Input	W	3010±7.5%		3010±7.5%
Refrigerant	Control	—	Electronic Expansion Valve		
	Charge	kg	3.8	3.8	3.8
Outline Dimensions (W×H×D)		mm	1107×1100×440		1107×1100×440
Net Weight		kg	90/101	90/101	92/103
Piping Connections	Liquid	Inch	Φ3/8	Φ3/8	Φ3/8
	Gas	Inch	Φ5/8	Φ5/8	Φ5/8
	Max. Length	m	30	50	30
	Max. Height	m	15	30	15

Continued 5

Model	Indoor unit		GFH36K3CI	GFH42K3CI	GFH36K3CI
	Product Code		CF060N0270	CF060N0290	CF060N0270
	Outdoor unit		GUHD36NK3CO	GUHD42NK3CO	GUHD36NM3CO
	Product Code		CF090W0300	CF090W0310	CF090W0410
Nominal Capacity	Cooling	kW	10.3	11.0	10.3
		Btu/h	35140	37530	35140
	Heating	kW	11.5	13.2	11.5
		Btu/h	39238	45038	39238
Power Input	Cooling	kW	3.208	3.427	3.17
	Heating	kW	3.066	3.4	3.1
EER/COP		W/W	3.21/3.75	3.21/3.88	3.25/3.71
Indoor Unit			GFH36K3CI	GFH42K3CI	GFH36K3CI
Power Supply		—	220-240V~ 50Hz		
Heat Exchange		—	Cross Fin Coil	Cross Fin Coil	Cross Fin Coil
Fan	Drive	—	direct	direct	direct
	Motor Output	kW	0.5×1	0.5×1	0.5×1
	Air Flow	m ³ /h	2300/2110/1850	2300/2110/1850	2300/2110/1850
	Rated Ext. Static Pressure	Pa	37	37	37
Sound Pressure Level(H/M/L)		dB(A)	53/50/46	53/50/46	53/50/46
Air Filter		—	Standard washable synthetic		
Drain Piping		mm	Φ20×1.2	Φ20×1.2	Φ20×1.2
Outline Dimensions (W×H×D)		mm	1226×290×775	1226×290×775	1226×290×775
Net Weight		kg	57	57	57
Outdoor Unit			GUHD36NK3CO	GUHD42NK3CO	GUHD36NM3CO
Power Supply		—	220-240V~ 50Hz		380-415V 3N~ 50Hz
Heat Exchange		—	Cross Fin Coil		Cross Fin Coil
Compressor	Type	—	ROTARY		ROTARY
	Power Input	W	3010±7.5%		3010±7.5%
Refrigerant	Control	—	Electronic Expansion Valve		
	Charge	kg	3.5	3.8	3.5
Outline Dimensions (W×H×D)		mm	1107×1100×440		1107×1100×440
Net Weight		kg	86	90	95
Piping Connections	Liquid	Inch	Φ3/8	Φ3/8	Φ3/8
	Gas	Inch	Φ5/8	Φ5/8	Φ5/8
	Max. Length	m	30	50	30
	Max. Height	m	15	30	15

Continued 6

Model	Indoor unit		GFH36K3CI	GFH42K3CI	GFH36K3CI
	Product Code		CF060N0270	CF060N0290	CF060N0270
	Outdoor unit		GUHD36NK3C10	GUHD42NK3C10	GUHD36NM3C10
	Product Code		CF090W0530	CF090W0540	CF090W0560
Nominal Capacity	Cooling	kW	10.0	11.0	10.0
		Btu/h	34100	37530	34100
	Heating	kW	11.0	12.0	11.0
		Btu/h	37500	40944	37500
Power Input	Cooling	kW	3.115	3.426	3.115
	Heating	kW	3.047	3.3	3.047
EER/COP		W/W	3.21/3.61	3.21/3.61	3.21/3.61
Indoor Unit			GFH36K3CI	GFH42K3CI	GFH36K3CI
Power Supply		—	220-240V~ 50Hz		
Heat Exchange		—	Cross Fin Coil		
Fan	Drive	—	direct		
	Motor Output	kW	0.5×1		
	Air Flow	m ³ /h	2300/2110/1850		2300/2110/1850
	Rated Ext. Static Pressure	Pa	37		37
Sound Pressure Level(H/M/L)		dB(A)	53/50/46		53/50/46
Air Filter		—	Standard washable synthetic		
Drain Piping		mm	Φ20×1.2	Φ20×1.2	Φ20×1.2
Outline Dimensions (W×H×D)		mm	1226×290×775	1226×290×775	1226×290×775
Net Weight		kg	57	57	57
Outdoor Unit			GUHD36NK3C10	GUHD42NK3C10	GUHD36NM3C10
Power Supply		—	220-240V~ 50Hz		380-415V 3N~ 50Hz
Heat Exchange		—	Cross Fin Coil		Cross Fin Coil
Compressor	Type	—	ROTARY		ROTARY
	Power Input	W	3010±7.5%		3010±7.5%
Refrigerant	Control	—	Electronic Expansion Valve		
	Charge	kg	3.8	3.8	3.8
Outline Dimensions (W×H×D)		mm	1107×1100×440		1107×1100×440
Net Weight		kg	89	89	88
Piping Connections	Liquid	Inch	Φ3/8	Φ3/8	Φ3/8
	Gas	Inch	Φ5/8	Φ5/8	Φ5/8
	Max. Length	m	30	50	30
	Max. Height	m	15	30	15

Continued: 7

Model	Indoor unit		GFH42K3CI	GFH42K3CI	GFH48K3CI
	Product Code		CF060N0290	CF060N0290	CF060N0280
	Outdoor unit		GUHD42NM3CO	GUHD42NM3CO	GUHD48NK3CO
	Product Code		CF090W0421	CF090W0420	CF090W0320
Nominal Capacity	Cooling	kW	11	11	14
		Btu/h	37530	37530	48000
	Heating	kW	12.5	13.2	16.5
		Btu/h	42650	45038	56300
Power Input	Cooling	kW	3.42	3.4	4.35
	Heating	kW	3.46	3.4	4.5
EER/COP		W/W	3.21/3.61	3.24/3.88	3.22/3.67
Indoor Unit			GFH42K3CI	GFH42K3CI	GFH48K3CI
Power Supply		—	220-240V~ 50Hz		
Heat Exchange		—	Cross Fin Coil		
Fan	Drive	—	direct		
	Motor Output	kW	0.5×1	0.5×1	0.5×1
	Air Flow	m ³ /h	2300/2110/1850	2300/2110/1850	2500/2300/2100
	Rated Ext. Static Pressure	Pa	37	37	50
Sound Pressure Level(H/M/L)		dB(A)	53/50/46	53/50/46	53/50/46
Air Filter		—	Standard washable synthetic		
Drain Piping		mm	Φ20×1.2	Φ20×1.2	Φ30×1.5
Outline Dimensions (W×H×D)		mm	1226×290×775	1226×290×775	1226×330×815
Net Weight		kg	57	57	64
Outdoor Unit			GUHD42NM3CO	GUHD42NM3CO	GUHD48NK3CO
Power Supply		—	380-415V 3N~ 50Hz		220-240V~ 50Hz
Heat Exchange		—	Cross Fin Coil		
Compressor	Type	—	ROTARY		
	Power Input	W	3010±7.5%	3010±7.5%	4220
Refrigerant	Control	—	Electronic Expansion Valve		
	Charge	kg	3.8	3.8	4.3
Outline Dimensions (W×H×D)		mm	1107×1100×440	1107×1100×440	1085×1365×427
Net Weight		kg	92	98	116
Piping Connections	Liquid	Inch	Φ3/8	Φ3/8	Φ3/8
	Gas	Inch	Φ5/8	Φ5/8	Φ5/8
	Max. Length	m	50	50	50
	Max. Height	m	30	30	30

Continued: 8

Model	Indoor unit		GFH42K3CI	GFH48K3CI	GFH48K3CI
	Product Code		CF060N0290	CF060N0280	CF060N0280
	Outdoor unit		GUHD42NM3C1O	GUHD48NM3C1O	GUHD48NK3C1O
	Product Code		CF090W0570	CF090W0580	CF090W0550
Nominal Capacity	Cooling	kW	11	14	14
		Btu/h	37530	48000	48000
	Heating	kW	12.0	16.0	16.0
		Btu/h	40944	54600	54600
Power Input	Cooling	kW	3.426	4.36	4.36
	Heating	kW	3.3	4.43	4.43
EER/COP		W/W	3.24/3.61	3.21/3.61	3.21/3.61
Indoor Unit			GFH42K3CI	GFH48K3CI	GFH48K3CI
Power Supply		—	220-240V~ 50Hz		
Heat Exchange		—	Cross Fin Coil		
Fan	Drive	—	direct		
	Motor Output	kW	0.5×1	0.5×1	0.5×1
	Air Flow	m ³ /h	2300/2110/1850	2500/2300/2100	2500/2300/2100
	Rated Ext. Static Pressure	Pa	37	50	50
Sound Pressure Level(H/M/L)		dB(A)	53/50/46	53/50/46	53/50/46
Air Filter		—	Standard washable synthetic		
Drain Piping		mm	Φ20×1.2	Φ30×1.5	Φ30×1.5
Outline Dimensions (W×H×D)		mm	1226×290×775	1226×330×815	1226×330×815
Net Weight		kg	57	64	64
Outdoor Unit			GUHD42NM3C1O	GUHD48NM3C1O	GUHD48NK3C1O
Power Supply		—	380-415V 3N~ 50Hz		220-240V~ 50Hz
Heat Exchange		—	Cross Fin Coil		
Compressor	Type	—	ROTARY		
	Power Input	W	3010±7.5%	4220	4220
Refrigerant	Control	—	Electronic Expansion Valve		
	Charge	kg	3.8	4.3	4.3
Outline Dimensions (W×H×D)		mm	1107×1100×440	1085×1365×427	
Net Weight		kg	88	116	116
Piping Connections	Liquid	Inch	Φ3/8	Φ3/8	Φ3/8
	Gas	Inch	Φ5/8	Φ5/8	Φ5/8
	Max. Length	m	50	50	50
	Max. Height	m	30	30	30

Continued: 9

Model	Indoor unit		GFH48K3CI	GFH60K3CI	GFH60K3CI
	Product Code		CF060N0280	ED020N0440	ED020N0440
	Outdoor unit		GUHD48NM3CO	GUHD60NM3CO	GUHD60NM3C1O
	Product Code		CF090W0430	CF090W0440	CF090W0590
Nominal Capacity	Cooling	kW	14	17	17
		Btu/h	48000	58000	58000
	Heating	kW	16.5	18	18
		Btu/h	56300	61400	61400
Power Input	Cooling	kW	4.35	5.29	5.3
	Heating	kW	4.5	4.98	5.0
EER/COP		W/W	3.22/3.67	3.21/3.61	3.21/3.61
Indoor Unit			GFH48K3CI	GFH60K3CI	GFH60K3CI
Power Supply		—	220-240V~ 50Hz		
Heat Exchange		—	Cross Fin Coil	Cross Fin Coil	Cross Fin Coil
Fan	Drive	—	direct	direct	direct
	Motor Output	kW	0.5×1	0.33×1	0.33×1
	Air Flow	m ³ /h	2500/2300/2100	3150	3150
	Rated Ext. Static Pressure	Pa	50	50	50
Sound Pressure Level(H/M/L)		dB(A)	53/50/46	54/51/48	54/51/48
Air Filter		—	Standard washable synthetic		
Drain Piping		mm	Φ30×1.5	Φ30×1.5	Φ30×1.5
Outline Dimensions (W×H×D)		mm	1226×330×815	1463×389×799	1463×389×799
Net Weight		kg	64	87	87
Outdoor Unit			GUHD48NM3CO	GUHD60NM3CO	GUHD60NM3C1O
Power Supply		—	380-415V 3N~ 50Hz		
Heat Exchange		—	Cross Fin Coil	Cross Fin Coil	Cross Fin Coil
Compressor	Type	—	ROTARY	ROTARY	ROTARY
	Power Input	W	4220	4220	4220
Refrigerant	Control	—	Electronic Expansion Valve		
	Charge	kg	4.3	5.5	5.5
Outline Dimensions (W×H×D)		mm	1085×1365×427	1085×1365×427	1085×1365×427
Net Weight		kg	116	121	118
Piping Connections	Liquid	inch	Φ3/8	Φ3/8	Φ3/8
	Gas	inch	Φ5/8	Φ3/4	Φ3/4
	Max. Length	m	50	50	50
	Max. Height	m	30	30	30

4.1.2 Cassette Type

Model	Indoor unit		GKH12K3CI	GKH18K3CI	GKH24K3CI
	Product Code		ET010N0170	ET010N0180	ET010N0190
	Outdoor unit		GUHD12NK3CO	GUHD18NK3CO	GUHD24NK3CO
	Product Code		CF090W0350	CF090W0281	CF090W0290
Nominal Capacity	Cooling	kW	3.4	5.3	7
		Btu/h	11600	18000	24000
	Heating	kW	3.7	6.15	8.0
		Btu/h	12600	21000	27000
Power Input	Cooling	kW	1.03	1.65	2.18
	Heating	kW	1.025	1.7	2.21
EER/COP		W/W	3.3/3.61	3.21/3.62	3.21/3.62
Indoor Unit			GKH12K3CI	GKH18K3CI	GKH24K3CI
Power Supply		—	220-240V~ 50Hz		
Heat Exchange		—	Cross Fin Coil		
Fan	Drive	—	direct	direct	direct
	Motor Output	kW	0.011x1	0.035x1	0.040x1
	Air Flow	m ³ /h	550/450/350	1180/1080/1000	1400/1270/1170
Sound Pressure Level(H/M/L)		dB(A)	47/45/43	47/45/43	51/49/48
Air Filter		—	Standard washable synthetic		
Drain Piping		mm	Φ32×3	Φ32×3	Φ32×3
Outline Dimensions (W×H×D)		mm	600×230×600	840×240×840	840×240×840
Net Weight		kg	20	27	27
Panel Dimensions (Outline/Package) (W×H×D)		mm	650 ×50×650	950×60×950	950×60×950
			673 ×117×733	1028×130×1043	1028×130×1043
Panel Weight(Net/Gross)		kg	2.5/3.5	6.5/10	6.5/10
Outdoor Unit			GUHD12NK3CO	GUHD18NK3CO	GUHD24NK3CO
Power Supply		—	220-240V~ 50Hz		
Heat Exchange		—	Cross Fin Coil		
Compressor	Type	—	ROTARY	ROTARY	ROTARY
	Power Input	W	1070	1630	2200
Refrigerant	Control	—	Capillary Tube	Electronic Expansion Valve	
	Charge	kg	1.35	1.4	2.4
Outline Dimensions (W×H×D)		mm	776×320×540	955×700×396	980×790×427
Net Weight		kg	30	48	65
Piping Connections	Liquid	Inch	Φ1/4	Φ1/4	Φ3/8
	Gas	Inch	Φ3/8	Φ1/2	Φ5/8
	Max. Length	m	20	20	30
	Max. Height	m	15	15	15

Continued: 1

Model	Indoor unit		GKH12K3CI	GKH18K3CI	GKH24K3CI
	Product Code		ET010N0170	ET010N0180	ET010N0190
	Outdoor unit		GUHD12NK3C1O	GUHD18NK3C1O	GUHD24NK3C1O
	Product Code		CF090W0350	CF090W0500	CF090W0510
Nominal Capacity	Cooling	kW	3.4	5.3	7
		Btu/h	11600	18000	24000
	Heating	kW	3.7	6.15	8.00
		Btu/h	12600	21000	27000
Power Input	Cooling	kW	1.03	1.65	2.18
	Heating	kW	1.025	1.7	2.21
EER/COP		W/W	3.3/3.61	3.21/3.62	3.21/3.62
Indoor Unit			GKH12K3CI	GKH18K3CI	GKH24K3CI
Power Supply		—	220-240V~ 50Hz		
Heat Exchange		—	Cross Fin Coil		
Fan	Drive	—	direct	direct	direct
	Motor Output	kW	0.011×1	0.035×1	0.040×1
	Air Flow	m ³ /h	550/450/350	1180/1080/1000	1400/1270/1170
Sound Pressure Level(H/M/L)		dB(A)	47/45/43	47/45/43	51/49/48
Air Filter		—	Standard washable synthetic		
Drain Piping		mm	Φ32×3	Φ32×3	Φ32×3
Outline Dimensions (W×H×D)		mm	600×230×600	840×240×840	840×240×840
Net Weight		kg	20	27	27
Panel Dimensions (Outline/Package) (W×H×D)		mm	650 ×50×650	950×60×950	950×60×950
			673 ×117×733	1028×130×1043	1028×130×1043
Panel Weight(Net/Gross)		kg	2.5/3.5	6.5/10	6.5/10
Outdoor Unit			GUHD12NK3C1O	GUHD18NK3C1O	GUHD24NK3C1O
Power Supply		—	220-240V~ 50Hz		
Heat Exchange		—	Cross Fin Coil		
Compressor	Type	—	ROTARY	ROTARY	ROTARY
	Power Input	W	1070	1630	2200
Refrigerant	Control	—	Capillary Tube	Electronic Expansion Valve	
	Charge	kg	1.25	1.4	2.4
Outline Dimensions (W×H×D)		mm	848×540×320	955×700×396	980×790×427
Net Weight		kg	33	46	65
Piping Connections	Liquid	Inch	Φ1/4	Φ1/4	Φ3/8
	Gas	Inch	Φ3/8	Φ1/2	Φ5/8
	Max. Length	m	20	20	30
	Max. Height	m	15	15	15

Continued: 2

Model	Indoor unit		GKH30K3CI	GKH36K3CI	GKH42K3CI
	Product Code		ET010N0200	ET010N0210	ET010N0230
	Outdoor unit		GUHD30NK3CO	GUHD36NK3CO	GUHD42NK3CO
	Product Code		CF090W0330	CF090W0301	CF090W0311
Nominal Capacity	Cooling	kW	8.8	10	11
		Btu/h	30000	34120	37530
	Heating	kW	9.5	11.0	12.0
		Btu/h	32400	37532	40944
Power Input	Cooling	kW	2.74	3.115	3.42
	Heating	kW	2.63	3.047	3.324
EER/COP		W/W	3.21/3.61	3.21/3.61	3.21/3.61
Indoor Unit			GKH30K3CI	GKH36K3CI	GKH42K3CI
Power Supply		—	220-240V~ 50Hz		
Heat Exchange		—	Cross Fin Coil		
Fan	Motor Output	kW	0.060×1	0.06	0.06
	Air Flow	m ³ /h	1660/1570/1500	1660/1570/1500	1660/1570/1500
Sound Pressure Level(H/M/L)		dB(A)	53/51/48	53/51/48	53/51/48
Air Filter		—	Standard washable synthetic		
Drain Piping		mm	Φ32×3	Φ32×3	Φ32×3
Outline Dimensions		mm	840×320×840	840×320×840	840×320×840
Net Weight		kg	32	32	32
Panel Dimensions (Outline/Package)(W×H×D)		mm	950×60×950/	950×60×950/	950×60×950
			1028×130×1043	1028×130×1043	1028×130×1043
Panel Weight(Net/Gross)		kg	6.5/10	6.5/10	6.5/10
Outdoor Unit			GUHD30NK3CO	GUHD36NK3CO	GUHD42NK3CO
Power Supply		—	220-240V~ 50Hz		
Heat Exchange		—	Cross Fin Coil		
Compressor	Type	—	ROTARY	ROTARY	
	Power Input	W	2200	3010±7.5%	
Refrigerant	Control	—	Electronic Expansion Valve		
	Charge	kg	2.6	3.8	3.8
Outline Dimensions (W×H×D)		mm	980×790×427	1107×1100×440	
Net Weight		kg	68	90	90
Piping Connections	Liquid	Inch	Φ3/8	Φ3/8	Φ3/8
	Gas	Inch	Φ5/8	Φ5/8	Φ5/8
	Max. Length	m	30	30	50
	Max. Height	m	15	15	30

Continued: 3

Model	Indoor unit		GKH36K3CI	GKH42K3CI
	Product Code		ET010N0210	ET010N0230
	Outdoor unit		GUHD36NK3CO	GUHD42NK3CO
	Product Code		CF090W0300	CF090W0310
Nominal Capacity	Cooling	kW	10.3	11
		Btu/h	35140	37530
	Heating	kW	11.2	12.4
		Btu/h	38210	42300
Power Input	Cooling	kW	3.2	3.427
	Heating	kW	3.0	3.434
EER/COP		W/W	3.22/3.73	3.21/3.61
Indoor Unit			GKH36K3CI	GKH42K3CI
Power Supply		—	220-240V~ 50Hz	
Heat Exchange		—	Cross Fin Coil	
Fan	Type	—	Centrifugal fan	
	Drive	—	direct	direct
	Motor Output	kW	0.06	0.06
	Air Flow	m ³ /h	1660/1570/1500	1660/1570/1500
Sound Pressure Level(H/M/L)		dB(A)	53/51/48	53/51/48
Air Filter		—	Standard washable synthetic	
Drain Piping		mm	Φ32×3	Φ32×3
Outline Dimensions		mm	840×320×840	840×320×840
Net Weight		kg	32	32
Panel Dimensions (Outline/Package) (W×H×D)		mm	950×60×950/	950×60×950
			1028×130×1043	1028×130×1043
Panel Weight(Net/Gross)		kg	6.5/10	6.5/10
Outdoor Unit			GUHD36NK3CO	GUHD42NK3CO
Power Supply		—	220-240V~ 50Hz	
Heat Exchange		—	Cross Fin Coil	
Compressor	Type	—	ROTARY	
	Power Input	W	3010±7.5%	
Refrigerant	Control	—	Electronic Expansion Valve	
	Charge	kg	3.5	3.8
Outline Dimensions (W×H×D)		mm	1107×1100×440	
Net Weight		kg	86	90
Piping Connections	Liquid	Inch	Φ3/8	Φ3/8
	Gas	Inch	Φ5/8	Φ5/8
	Max. Length	m	30	50
	Max. Height	m	15	30

Continued:4

Model	Indoor unit		GKH30K3CI	GKH36K3CI	GKH42K3CI
	Product Code		ET010N0200	ET010N0210	ET010N0230
	Outdoor unit		GUHD30NK3C1O	GUHD36NK3C1O	GUHD42NK3C1O
	Product Code		CF090W0520	CF090W0531	CF090W0541
Nominal Capacity	Cooling	kW	8.8	10.0	11
		Btu/h	30000	34100	37530
	Heating	kW	9.5	11.0	12.0
		Btu/h	32400	37500	40944
Power Input	Cooling	kW	2.74	3.115	3.426
	Heating	kW	2.63	3.047	3.3
EER/COP		W/W	3.21/3.61	3.21/3.61	3.21/3.61
Indoor Unit			GKH30K3CI	GKH36K3CI	GKH42K3CI
Power Supply		—	220-240V~ 50Hz		
Heat Exchange		—	Cross Fin Coil		
Fan	Drive	—	direct	direct	direct
	Motor Output	kW	0.060×1	0.06	0.06
	Air Flow	m ³ /h	1660/1570/1500	1660/1570/1500	1660/1570/1500
Sound Pressure Level(H/M/L)		dB(A)	53/51/48	53/51/48	53/51/48
Air Filter		—	Standard washable synthetic		
Drain Piping		mm	Φ32×3	Φ32×3	Φ32×3
Outline Dimensions		mm	840×320×840	840×320×840	840×320×840
Net Weight		kg	32	32	32
Panel Dimensions (Outline/Package) (W×H×D)		mm	950×60×950	950×60×950	950×60×950
			1028×130×1043	1028×130×1043	1028×130×1043
Panel Weight(Net/Gross)		kg	6.5/10	6.5/10	6.5/10
Outdoor Unit			GUHD30NK3C1O	GUHD36NK3C1O	GUHD42NK3C1O
Power Supply		—	220-240V~ 50Hz		
Heat Exchange		—	Cross Fin Coil		
Compressor	Type	—	ROTARY	ROTARY	
	Power Input	W	2200	3010±7.5%	
Refrigerant	Control	—	Electronic Expansion Valve		
	Charge	kg	2.6	3.8	3.8
Dimensions (W×H×D)		mm	980×790×427	1107×1100×440	
Net Weight		kg	68	89	89
Piping Connections	Liquid	Inch	Φ3/8	Φ3/8	Φ3/8
	Gas	Inch	Φ5/8	Φ5/8	Φ5/8
	Max. Length	m	30	30	50
	Max. Height	m	15	15	30

Continued:5

Model	Indoor unit		GKH36K3CI	GKH42K3CI
	Product Code		ET010N0210	ED020N0310
	Outdoor unit		GUHD36NM3CO	GUHD42NM3CO
	Product Code		CF090W04101	CF090W0421
Nominal Capacity	Cooling	kW	10	11
		Btu/h	34120	37530
	Heating	kW	11.0	12.0
		Btu/h	37532	42300
Power Input	Cooling	kW	3.115	3.42
	Heating	kW	3.047	3.324
EER/COP		W/W	3.21/3.61	3.21/3.61
Indoor Unit			GKH36K3CI	GKH42K3CI
Power Supply		—	220-240V~ 50Hz	
Heat Exchange		—	Cross Fin Coil	Cross Fin Coil
Fan	Drive	—	direct	direct
	Motor Output	kW	0.06	0.06
	Air Flow	m ³ /h	1660/1570/1500	1660/1570/1500
Sound Pressure Level(H/M/L)		dB(A)	53/51/48	53/51/48
Air Filter		—	Standard washable synthetic	
Drain Piping		mm	Φ32×3	Φ32×3
Outline Dimensions		mm	840×320×840	840×320×840
Net Weight		kg	32	32
Panel Dimensions (Outline/Package) (W×H×D)		mm	950×60×950	950×60×950
			11028×130×1043	1028×130×1043
Panel Weight(Net/Gross)		kg	6.5/10	6.5/10
Outdoor Unit			GUHD36NM3CO	GUHD42NM3CO
Power Supply		—	380-4150V 3N~ 50Hz	380-4150V 3N~ 50Hz
Heat Exchange		—	Cross Fin Coil	Cross Fin Coil
Compressor	Type	—	ROTARY	ROTARY
	Power Input	W	3010±7.5%	3010±7.5%
Refrigerant	Control	—	Electronic Expansion Valve	
	Charge	kg	3.8	3.8
Outline Dimensions (W×H×D)		mm	1107×1100×440	1107×1100×440
Net Weight		kg	92	92
Piping Connections	Liquid	Inch	Φ3/8	Φ3/8
	Gas	Inch	Φ5/8	Φ5/8
	Max. Length	m	30	50
	Max. Height	m	15	30

Continued:6

Model	Indoor unit		GKH36K3CI	GKH42K3CI
	Product Code		ET010N0210	ED020N0310
	Outdoor unit		GUHD36NM3CO	GUHD42NM3CO
	Product Code		CF090W04100	CF090W0420
Nominal Capacity	Cooling	kW	10.3	11
		Btu/h	35140	37530
	Heating	kW	11.2	12.4
		Btu/h	38210	42300
Power Input	Cooling	kW	3.18	3.3
	Heating	kW	3.1	3.3
EER/COP		W/W	3.24/3.61	3.33/3.75
Indoor Unit			GKH36K3CI	GKH42K3CI
Power Supply		—	220-240V~ 50Hz	
Heat Exchange		—	Cross Fin Coil	Cross Fin Coil
Fan	Drive	—	direct	direct
	Motor Output	kW	0.06	0.06
	Air Flow	m ³ /h	1660/1570/1500	1660/1570/1500
Sound Pressure Level(H/M/L)		dB(A)	53/51/48	53/51/48
Air Filter		—	Standard washable synthetic	
Drain Piping		mm	Φ32×3	Φ32×3
Outline Dimensions		mm	840×320×840	840×320×840
Net Weight		kg	32	32
Panel Dimensions (Outline/Package) (W×H×D)		mm	950×60×950	950×60×950
			11028×130×1043	1028×130×1043
Panel Weight(Net/Gross)		kg	6.5/10	6.5/10
Outdoor Unit			GUHD36NM3CO	GUHD42NM3CO
Power Supply		—	380-4150V 3N~ 50Hz	380-4150V 3N~ 50Hz
Heat Exchange		—	Cross Fin Coil	Cross Fin Coil
Compressor	Type	—	ROTARY	ROTARY
	Power Input	W	3010±7.5%	3010±7.5%
Refrigerant	Control	—	Electronic Expansion Valve	
	Charge	kg	3.8	3.8
Outline Dimensions (W×H×D)		mm	1107×1100×440	1107×1100×440
Net Weight		kg	95	98
Piping Connections	Liquid	Inch	Φ3/8	Φ3/8
	Gas	Inch	Φ5/8	Φ5/8
	Max. Length	m	30	50
	Max. Height	m	15	30

Continued:7

Model	Indoor unit		GKH36K3CI	GKH42K3CI
	Product Code		CF060N0270	ET010N0230
	Outdoor unit		GUHD36NM3C1O	GUHD42NM3C1O
	Product Code		CF090W0560	CF090W0570
Nominal Capacity	Cooling	kW	10.0	11.0
		Btu/h	34100	37530
	Heating	kW	11.0	12.0
		Btu/h	37500	40944
Power Input	Cooling	kW	3.115	3.426
	Heating	kW	3.047	3.3
EER/COP		W/W	3.21/3.61	3.22/3.61
Indoor Unit			GKH36K3CI	GKH42K3CI
Power Supply		—	220-240V~ 50Hz	
Heat Exchange		—	Cross Fin Coil	Cross Fin Coil
Fan	Drive	—	direct	direct
	Motor Output	kW	0.06	0.06
	Air Flow	m ³ /h	1660/1570/1500	1660/1570/1500
Sound Pressure Level(H/M/L)		dB(A)	53/51/48	53/51/48
Air Filter		—	Standard washable synthetic	
Drain Piping		mm	Φ32×3	Φ32×3
Outline Dimensions		mm	840×320×840	840×320×840
Net Weight		kg	32	32
Panel Dimensions (Outline/Package) (W×H×D)		mm	950×60×950	950×60×950
			1028×130×1043	1028×130×1043
Panel Weight(Net/Gross)		kg	6.5/10	6.5/10
Outdoor Unit			GUHD36NM3C1O	GUHD42NM3C1O
Power Supply		—	380-4150V 3N~ 50Hz	380-4150V 3N~ 50Hz
Heat Exchange		—	Cross Fin Coil	Cross Fin Coil
Compressor	Type	—	ROTARY	ROTARY
	Power Input	W	3010±7.5%	3010±7.5%
Refrigerant	Control	—	Electronic Expansion Valve	
	Charge	kg	3.8	3.8
Outline Dimensions (W×H×D)		mm	1107×1100×440	1107×1100×440
Net Weight		kg	88	88
Piping Connections	Liquid	Inch	Φ3/8	Φ3/8
	Gas	Inch	Φ5/8	Φ5/8
	Max. Length	m	30	50
	Max. Height	m	15	30

4.1.3 Ceiling Type

Model	Indoor unit		GTH09K3CI	GTH12K3CI
	Product Code		ED020N0171	ED020N0181
	Outdoor unit		GUHD09NK3CO	GUHD12NK3CO
	Product Code		CF090W0260	CF090W0270
Nominal Capacity	Cooling	kW	3.0	3.4
		Btu/h	10236	11600
	Heating	kW	3.0	3.8
		Btu/h	10236	13000
Power Input	Cooling	kW	0.857	1.059
	Heating	kW	0.75	0.927
EER/COP		W/W	3.5/4.0	3.21/4.1
Indoor Unit		GTH09K3CI		GTH12K3CI
Power Supply		—	220-240V~ 50Hz	
Heat Exchange		—	Cross Fin Coil	
Fan	Drive	—	Direct	
	Motor Output	kW	0.008×1	0.015×1
	Air Flow	m ³ /h	650/550/450	700/600/500
Sound Pressure Level(H/M/L)		dB(A)	39/37/35	39/37/35
Air Filter		—	Standard washable synthetic	
Drain Piping		mm	Φ17×1.75	Φ17×1.75
Outline Dimensions (W×H×D)		mm	1220×225×700	1220×225×700
Net Weight		kg	40	40
Outdoor Unit		GUHD09NK3CO		GUHD12NK3CO
Power Supply		—	220-240V~ 50Hz	
Heat Exchange		—	Cross Fin Coil	
Compressor	Type	—	ROTARY	ROTARY
	Power Input	W	1070	1070
Refrigerant	Control	—	Capillary Tube	
	Charge	kg	1.2	1.35
Outline Dimensions (W×H×D)		mm	776 ×540×320	776 ×540×320
Net Weight		kg	28	30
Piping Connections	Liquid	Inch	Φ1/4	Φ1/4
	Gas	Inch	Φ3/8	Φ3/8
	Max. Length	m	20	20
	Max. Height	m	15	15

Continued:1

Model	Indoor unit		GTH09K3CI	GTH12K3CI
	Product Code		ED020N0171	ED020N0181
	Outdoor unit		GUHD09NK3C1O	GUHD12NK3C1O
	Product Code		CF090W0340	CF090W0350
Nominal Capacity	Cooling	kW	3.0	3.4
		Btu/h	10236	11600
	Heating	kW	3.0	3.8
		Btu/h	10236	13000
Power Input	Cooling	kW	0.857	1.059
	Heating	kW	0.75	0.927
EER/COP		W/W	3.5/4.0	3.21/4.1
Indoor Unit			GTH09K3CI	GTH12K3CI
Power Supply		—	220-240V~ 50Hz	
Heat Exchange		—	Cross Fin Coil	
Fan	Drive	—	Direct	
	Motor Output	kW	0.008×1	0.015×1
	Air Flow	m ³ /h	650/550/450	700/600/500
Sound Pressure Level(H/M/L)		dB(A)	39/37/35	39/37/35
Air Filter		—	Standard washable synthetic	
Drain Piping		mm	Φ17×1.75	Φ17×1.75
Outline Dimensions (W×H×D)		mm	1220×225×700	1220×225×700
Net Weight		kg	40	40
Outdoor Unit			GUHD09NK3C1O	GUHD12NK3C1O
Power Supply		—	220-240V~ 50Hz	
Heat Exchange		—	Cross Fin Coil	
Compressor	Type	—	ROTARY	ROTARY
	Power Input	W	1070	1070
Refrigerant	Control	—	Capillary Tube	
	Charge	kg	1.2	1.25
Outline Dimensions (W×H×D)		mm	848×540×320	848×540×320
Net Weight		kg	33	33
Piping Connections	Liquid	Inch	Φ1/4	Φ1/4
	Gas	Inch	Φ3/8	Φ3/8
	Max. Length	m	20	20
	Max. Height	m	15	15

Continued:2

Model	Indoor unit		GTH18K3CI	GTH24K3CI	GTH30K3CI
	Product Code		ED020N0191	ED020N0200	ED020N0210
	Outdoor unit		GUHD18NK3CO	GUHD24NK3CO	GUHD30NK3CO
	Product Code		CF090W0281	CF090W0290	CF090W0330
Nominal Capacity	Cooling	kW	5.3	7	8.8
		Btu/h	18000	24000	30000
	Heating	kW	6.15	8	9.5
		Btu/h	21000	27000	32400
Power Input	Cooling	kW	1.65	2.18	2.74
	Heating	kW	1.7	2.21	2.63
EER/COP		W/W	3.21/3.62	3.21/3.62	3.21/3.61
Indoor Unit			GTH18K3CI	GTH24K3CI	GTH30K3CI
Power Supply		—	220-240V~ 50Hz		
Heat Exchange		—	Cross Fin Coil		
Fan	Drive	—	Direct	Direct	Direct
	Motor Output	kW	0.02×1	0.05×1	0.075×1
	Air Flow	m ³ /h	900/800/700	1200/1050/900	1600/1450/1300
Sound Pressure Level(H/M/L)		dB(A)	45/42/39	52/49/46	50/48/46
Air Filter		—	Standard washable synthetic		
Drain Piping		mm	Φ17×1.75	Φ17×1.75	Φ17×1.75
Outline Dimensions (W×H×D)		mm	1220×225×700	1220×225×700	1420×245×700
Net Weight		kg	42	43	51
Outdoor Unit			GUHD18NK3CO	GUHD24NK3CO	GUHD30NK3CO
Power Supply		—	220-240V~ 50Hz		
Heat Exchange		—	Cross Fin Coil		
Compressor	Type	—	ROTARY	ROTARY	ROTARY
	Power Input	W	1630	2200	2200
Refrigerant	Control	—	Electronic Expansion Valve		
	Charge	kg	1.4	2.4	2.6
Outline Dimensions (W×H×D)		mm	955×700×396	980×790×427	980×790×427
Net Weight		kg	48	65	68
Piping Connections	Liquid	Inch	Φ1/4	Φ3/8	Φ3/8
	Gas	Inch	Φ1/2	Φ5/8	Φ5/8
	Max. Length	m	20	30	30
	Max. Height	m	15	15	15

Continued:3

Model	Indoor unit		GTH18K3CI	GTH24K3CI	GTH30K3CI
	Product Code		ED020N0191	ED020N0200	ED020N0210
	Outdoor unit		GUHD18NK3C10	GUHD24NK3C10	GUHD30NK3C10
	Product Code		CF090W0500	CF090W0510	CF090W0520
Nominal Capacity	Cooling	kW	5.3	7	8.8
		Btu/h	18000	24000	30000
	Heating	kW	6.15	8	9.5
		Btu/h	21000	27000	32400
Power Input	Cooling	kW	1.65	2.18	2.74
	Heating	kW	1.7	2.21	2.63
EER/COP		W/W	3.21/3.61	3.21/3.62	3.21/3.61
Indoor Unit			GTH18K3CI	GTH24K3CI	GTH30K3CI
Power Supply		—	220-240V~ 50Hz		
Heat Exchange		—	Cross Fin Coil		
Fan	Drive	—	Direct	Direct	Direct
	Motor Output	kW	0.02×1	0.05×1	0.075×1
	Air Flow	m ³ /h	900/800/700	1200/1050/900	1600/1450/1300
Sound Pressure Level(H/M/L)		dB(A)	45/42/39	52/49/46	50/48/46
Air Filter		—	Standard washable synthetic		
Drain Piping		mm	Φ17×1.75	Φ17×1.75	Φ17×1.75
Outline Dimensions (W×H×D)		mm	1220×225×700	1220×225×700	1420×245×700
Net Weight		kg	42	43	51
Outdoor Unit			GUHD18NK3C10	GUHD24NK3C10	GUHD30NK3C10
Power Supply		—	220-240V~ 50Hz		
Heat Exchange		—	Cross Fin Coil		
Fan	Type	—	Axial fan		
	Fan Motor Speed	rpm	840	840	840
Compressor	Type	—	ROTARY	ROTARY	ROTARY
	Power Input	W	1630	2200	2200
Refrigerant	Control	—	Electronic Expansion Valve		
	Charge	kg	1.4	2.4	2.6
Outline Dimensions (W×H×D)		mm	955×700×396	980×790×427	980×790×427
Net Weight		kg	46	65	68
Piping Connections	Liquid	Inch	Φ1/4	Φ3/8	Φ3/8
	Gas	Inch	Φ1/2	Φ5/8	Φ5/8
	Max. Length	m	20	30	30
	Max. Height	m	15	15	15

Continued:4

Model	Indoor unit		GTH36K3CI	GTH42K3CI	GTH36K3CI
	Product Code		ED020N0220	ED020N0310	ED020N0220
	Outdoor unit		GUHD36NK3CO	GUHD42NK3CO	GUHD36NM3CO
	Product Code		CF090W0301	CF090W0311	CF090W0411
Nominal Capacity	Cooling	kW	10.5	11.5	10.5
		Btu/h	35826	39238	35800
	Heating	kW	11.5	12.5	11.5
		Btu/h	39238	42650	39238
Power Input	Cooling	kW	3.27	3.58	3.27
	Heating	kW	3.18	3.46	3.18
EER/COP		W/W	3.21/3.61	3.21/3.61	3.21/3.61
Indoor Unit			GTH36K3CI	GTH42K3CI	GTH36K3CI
Power Supply		—	220-240V~ 50Hz		220-240V~ 50Hz
Heat Exchange		—	Cross Fin Coil		Cross Fin Coil
Fan	Drive	—	Direct	Direct	Direct
	Motor Output	kW	0.15	0.15	0.15
	Air Flow	m3/h	2000/1630/1520	2000/1630/1520	2000/1630/1520
Sound Pressure Level(H/M/L)		dB(A)	54/51/48	54/51/48	54/51/48
Air Filter		—	Standard washable synthetic		
Drain Piping		mm	Φ17×1.75	Φ17×1.75	Φ17×1.75
Outline Dimensions (W×H×D)		mm	1420×245×700	1420×245×700	1420×245×700
Net Weight		kg	53	55	53
Outdoor Unit			GUHD36NK3CO	GUHD42NK3CO	GUHD36NM3CO
Power Supply		—	220-240V~ 50Hz		380-415V 3N~ 50Hz
Heat Exchange		—	Cross Fin Coil		Cross Fin Coil
Compressor	Type	—	ROTARY		ROTARY
	Power Input	W	3010±7.5%		3010±7.5%
Refrigerant	Control	—	Electronic Expansion Valve		
	Charge	kg	3.8	3.8	3.8
Outline Dimensions (W×H×D)		mm	1107×1100×440		1107×1100×440
Net Weight		kg	90	90	92
Piping Connections	Liquid	Inch	Φ3/8	Φ3/8	Φ3/8
	Gas	Inch	Φ5/8	Φ5/8	Φ5/8
	Max. Length	m	30	50	30
	Max. Height	m	15	30	15

Continued:5

Model	Indoor unit		GTH36K3CI	GTH42K3CI	GTH36K3CI
	Product Code		ED020N0220	ED020N0310	ED020N0220
	Outdoor unit		GUHD36NK3CO	GUHD42NK3CO	GUHD36NM3CO
	Product Code		CF090W0300	CF090W0310	CF090W0410
Nominal Capacity	Cooling	kW	10.6	11.9	10.5
		Btu/h	36160	40600	35800
	Heating	kW	12.0	13.5	12
		Btu/h	40940	46060	40940
Power	Cooling	kW	3.26	3.707	3.27
Input	Heating	kW	3.16	3.3	3.18
EER/COP		W/W	3.25/3.8	3.21/4.09	3.25/3.9
Indoor Unit			GTH36K3CI	GTH42K3CI	GTH36K3CI
Power Supply		—	220-240V~ 50Hz		220-240V~ 50Hz
Heat Exchange		—	Cross Fin Coil		Cross Fin Coil
Fan	Drive	—	Direct	Direct	Direct
	Motor Output	kW	0.15	0.15	0.15
	Air Flow	m ³ /h	2000/1630/1520	2000/1630/1520	2000/1630/1520
Sound Pressure Level(H/M/L)		dB(A)	54/51/48	54/51/48	54/51/48
Air Filter		—	Standard washable synthetic		
Drain Piping		mm	Φ17×1.75	Φ17×1.75	Φ17×1.75
Outline Dimensions (W×H×D)		mm	1420×245×700	1420×245×700	1420×245×700
Net Weight		kg	53	55	53
Outdoor Unit			GUHD36NK3CO	GUHD42NK3CO	GUHD36NM3CO
Power Supply		—	220-240V~ 50Hz		380-415V 3N~ 50Hz
Heat Exchange		—	Cross Fin Coil		Cross Fin Coil
Compressor	Type	—	ROTARY		ROTARY
	Power Input	W	3010±7.5%		3010±7.5%
Refrigerant	Control	—	Electronic Expansion Valve		
	Charge	kg	3.8	3.8	3.8
Outline Dimensions (W×H×D)		mm	1107×1100×440		1107×1100×440
Net Weight		kg	86	90	95
Piping Connections	Liquid	Inch	Φ3/8	Φ3/8	Φ3/8
	Gas	Inch	Φ5/8	Φ5/8	Φ5/8
	Max. Length	m	30	50	30
	Max. Height	m	15	30	15

Continued:6

Model	Indoor unit		GTH36K3CI	GTH42K3CI	GTH36K3CI
	Product Code		ED020N0220	ED020N0310	ED020N0220
	Outdoor unit		GUHD36NK3C10	GUHD42NK3C10	GUHD36NM3C10
	Product Code		CF090W0531	CF090W0541	CF090W0561
Nominal Capacity	Cooling	kW	10.5	11.5	10.5
		Btu/h	35800	39238	35800
	Heating	kW	11.2	12.5	11.2
		Btu/h	38200	42650	38200
Power Input	Cooling	kW	3.27	3.58	3.27
	Heating	kW	3.10	3.46	3.10
EER/COP		W/W	3.21/3.61	3.21/3.61	3.21/3.61
Indoor Unit			GTH36K3CI	GTH42K3CI	GTH36K3CI
Power Supply		—	220-240V~ 50Hz		220-240V~ 50Hz
Heat Exchange		—	Cross Fin Coil		Cross Fin Coil
Fan	Drive	—	Direct	Direct	Direct
	Motor Output	kW	0.15	0.15	0.15
	Air Flow	m ³ /h	2000/1630/1520	2000/1630/1520	2000/1630/1520
Sound Pressure Level(H/M/L)		dB(A)	54/51/48	54/51/48	54/51/48
Air Filter		—	Standard washable synthetic		
Drain Piping		mm	Φ17×1.75	Φ17×1.75	Φ17×1.75
Outline Dimensions (W×H×D)		mm	1420×245×700	1420×245×700	1420×245×700
Net Weight		kg	53	55	53
Outdoor Unit			GUHD36NK3C10	GUHD42NK3C10	GUHD36NM3C10
Power Supply		—	220-240V~ 50Hz		380-415V 3N~ 50Hz
Heat Exchange		—	Cross Fin Coil		Cross Fin Coil
Compressor	Type	—	ROTARY		ROTARY
	Power Input	W	3010±7.5%		3010±7.5%
Refrigerant	Control	—	Electronic Expansion Valve		
	Charge	kg	3.8	3.8	3.8
Outline Dimensions (W×H×D)		mm	1107×1100×440		1107×1100×440
Net Weight		kg	89	89	88
Piping Connections	Liquid	Inch	Φ3/8	Φ3/8	Φ3/8
	Gas	Inch	Φ5/8	Φ5/8	Φ5/8
	Max. Length	m	30	50	30
	Max. Height	m	15	30	15

Continued:7

Model	Indoor unit		GTH42K3CI	GTH48K3CI	GTH42K3CI
	Product Code		ED020N0310	ED020N0230	ED020N0310
	Outdoor unit		GUHD42NM3CO	GUHD48NM3CO	GUHD42NM3CO
	Product Code		CF090W0421	CF090W0430	CF090W0420
Nominal Capacity	Cooling	kW	11.5	14	11.9
		Btu/h	39238	48000	40600
	Heating	kW	12.5	16.5	13
		Btu/h	42650	56300	44356
Power Input	Cooling	kW	3.58	4.2	3.6
	Heating	kW	3.46	4.4	3.3
EER/COP		W/W	3.21/3.61	3.33/3.75	3.33/3.94
Indoor Unit			GTH42K3CI	GTH48K3CI	GTH42K3CI
Power Supply		—	220-240V~ 50Hz		
Heat Exchange		—	Cross Fin Coil		
Fan	Drive	—	Direct		
	Motor Output	kW	0.15	0.18	0.15
	Air Flow	m ³ /h	2000/1630/1520	2300/2100/1900	2000/1630/1520
Sound Pressure Level(H/M/L)		dB(A)	54/51/48	58/55/52	54/51/48
Air Filter		—	Standard washable synthetic		
Drain Piping		mm	Φ17×2.5	Φ17×1.75	Φ17×2.5
Outline Dimensions (W×H×D)		mm	1420×245×700	1700×245×700	1420×245×700
Net Weight		kg	55	64	55
Outdoor Unit			GUHD42NM3CO	GUHD48NM3CO	GUHD42NM3CO
Power Supply		—	380-415V 3N~ 50Hz		
Heat Exchange		—	Cross Fin Coil		Cross Fin Coil
Compressor	Type	—	ROTARY		ROTARY
	Power Input	W	3010±7.5%	4220	3010±7.5%
Refrigerant	Control	—	Electronic Expansion Valve		
	Charge	kg	3.8	4.3	3.8
Outline Dimensions (W×H×D)		mm	1107×1100×440	1085×1365×427	1107×1100×440
Net Weight		kg	92	116	98
Piping Connections	Liquid	Inch	Φ3/8	Φ3/8	Φ3/8
	Gas	Inch	Φ5/8	Φ5/8	Φ5/8
	Max. Length	m	50	50	50
	Max. Height	m	30	30	30

Continued:8

Model	Indoor unit		GTH42K3CI	GTH48K3CI	GTH48K3CI
	Product Code		ED020N0310	ED020N0230	ED020N0230
	Outdoor unit		GUHD42NM3C1O	GUHD48NM3C1O	GUHD48NK3C1O
	Product Code		CF090W0570	CF090W0580	CF090W0550
Nominal Capacity	Cooling	kW	11.3	14	14
		Btu/h	38555	48000	48000
	Heating	kW	12.5	16.0	16.0
		Btu/h	42650	54600	54600
Power Input	Cooling	kW	3.52	4.36	4.36
	Heating	kW	3.46	4.43	4.43
EER/COP		W/W	3.21/3.61	3.21/3.61	3.21/3.61
Indoor Unit			GTH42K3CI	GTH48K3CI	GTH48K3CI
Power Supply		—	220-240V~ 50Hz		
Heat Exchange		—	Cross Fin Coil		
Fan	Drive	—	Direct		
	Motor Output	kW	0.15	0.18	0.18
	Air Flow	m ³ /h	2000/1630/1520	2300/2100/1900	2300/2100/1900
Sound Pressure Level(H/M/L)		dB(A)	54/51/48	58/55/52	58/55/52
Air Filter		—	Standard washable synthetic		
Drain Piping		mm	Φ17×1.75	Φ17×1.75	Φ17×1.75
Outline Dimensions (W×H×D)		mm	1420×245×700	1700×245×700	
Net Weight		kg	55	64	64
Outdoor Unit			GUHD42NM3C1O	GUHD48NM3C1O	GUHD48NK3C1O
Power Supply		—	380-415V 3N~ 50Hz		220-240V~ 50Hz
Heat Exchange		—	Cross Fin Coil		
Refrigerant	Control	—	Electronic Expansion Valve		
	Charge	kg	3.8	4.3	4.3
Outline Dimensions (W×H×D)		mm	1107×1100×440	1085×1365×427	
Net Weight		kg	88	116	116
Piping Connections	Liquid	Inch	Φ3/8	Φ3/8	Φ3/8
	Gas	Inch	Φ5/8	Φ5/8	Φ5/8
	Max. Length	m	50	50	50
	Max. Height	m	30	30	30

Continued:9

Model	Indoor unit		GTH48K3CI	GTH60K3CI	GTH60K3CI
	Product Code		ED020N0230	ED020N0440	ED020N0440
	Outdoor unit		GUHD48NK3CO	GUHD60NM3CO	GUHD60NM3C1O
	Product Code		CF090W0320	CF090W0440	CF090W0590
Nominal Capacity	Cooling	kW	14	16	16
		Btu/h	48000	54500	54500
	Heating	kW	16.5	17.5	17.5
		Btu/h	56300	59700	59700
Power Input	Cooling	kW	4.2	4.98	4.98
	Heating	kW	4.4	4.84	4.84
EER/COP		WW	3.33/3.75	3.21/3.61	3.21/3.61
Indoor Unit			GTH48K3CI	GTH60K3CI	GTH60K3CI
Power Supply		—	220-240V~ 50Hz		220-240V~ 50Hz
Heat Exchange		—	Cross Fin Coil		Cross Fin Coil
Fan	Drive	—		Direct	Direct
	Motor Output	kW	0.18	0.25×1	0.25×1
	Air Flow	m ³ /h	2300/2100/1900	2300/2100/1900	2300/2100/1900
Sound Pressure Level(H/M/L)		dB(A)	58/55/52	58/55/52	58/55/52
Air Filter		—	Standard washable synthetic		
Drain Piping		mm	Φ17×1.75	Φ17×1.75	Φ17×1.75
Outline Dimensions (W×H×D)		mm	1700×245×700		1700×245×700
Net Weight		kg	64		65
Outdoor Unit			GUHD48NK3CO	GUHD60NM3CO	GUHD60NM3C1O
Power Supply		—	220-240V~ 50Hz	380-4150V 3N~ 50Hz	
Heat Exchange		—	Cross Fin Coil		
Compressor	Type	—	ROTARY	ROTARY	ROTARY
	Power Input	W	4220	4220	4220
Refrigerant	Control	—	Electronic Expansion Valve		
	Charge	kg	4.3	5.5	5.5
Outline Dimensions (W×H×D)		mm	1085×1365×427	1085×1365×427	1085×1365×427
Net Weight		kg	116	121	118
Piping Connections	Liquid	Inch	Φ3/8	Φ3/8	Φ3/8
	Gas	Inch	Φ5/8	Φ3/4	Φ3/4
	Max. Length	m	50	50	50
	Max. Height	m	30	30	30

Note: Nominal capacities are based on the following conditions.

Mode	Indoor	Outdoor
Cooling	DB: 27°C (80.6°F) WB: 19°C (66.2°F)	DB: 35°C (95°F) WB: 24°C (75.2°F)
Heating	DB: 20°C (68°F) WB: -1°C (-32°F)	DB: 7°C (44.6°F) WB: 6°C (42.8°F)
Piping Length	5m	

The air volume is measured at the relevant standard external static pressure.

Noise is tested in the Semianechoic room, so it should be slightly higher in the actual operation due to environmental change.

3.2 Operation Range

Mode	Range of Outdoor Temperature°C
Cooling	18°C/-15°C--48°C
Heating	-7°C-24°C

3.3 Electrical Data

Model	Compressor			Fan Motor FLA	Fuse/ Breaker Capacity	Min. Power Supply Cord
	Power Supply	Qty.	RLA			
	V,Ph,HZ	—	A	A	A	mm ²
GUHD09NK3CO/GUHD09NK3C1O	220-240 1, 50	1	4.8	0.35	5/16	2.5
GUHD12NK3CO/GUHD12NK3C1O		1	4.8	0.35	5/16	2.5
GUHD18NK3CO/GUHD18NK3C1O		1	8.38	0.58	5/20	4.0
GUHD24NK3CO/GUHD24NK3C1O		1	9.7	0.85	5/20	4.0
GUHD30NK3CO/GUHD30NK3C1O		1	9.7	0.85	5/20	4.0
GUHD36NK3CO/GUHD36NK3C1O		1	13.5	1.1	5/25	4.0
GUHD42NK3CO/GUHD42NK3C1O		1	13.5	1.1	5/25	4.0
GUHD48NK3CO/GUHD48NK3C1O		1	-	0.58	5/32	6.0
GUHD36NM3CO/GUHD36NM3C1O	380-415~ 3, 50	1	9.3	1.1	5/16	2.5
GUHD42NM3CO/GUHD42NM3C1O		1	9.3	1.1	5/16	2.5
GUHD48NM3CO/GUHD48NM3C1O		1	-	0.58	5/16	2.5
GUHD60NM3CO/GUHD60NM3C1O		1	-	0.8	5/16	2.5

Model	Power Supply	Fan Motor FLA	Fuse/ Breaker Capacity	Min. Power Supply Cord
	V,Ph,HZ	A	A	mm ²
GFH09K3CI	220-240 1, 50	0.31	5/6	1.0
GTH09K3CI		0.10	5/6	
GFH12K3CI		0.41	5/6	1.0
GTH12K3CI		0.10	3.15/6	
GKH12K3CI		0.2	5/6	1.0
GFH18K3CI		0.71	5/6	
GTH18K3CI		0.21	3.15/6	1.0
GKH18K3CI		0.35	5/6	
GFH24K3CI		1.52	5/6	1.0
GTH24K3CI		0.51	3.15/6	
GKH24K3CI		0.40	5/6	1.0
GFH30K3CI		1.52	5/6	
GTH30K3CI		0.76	3.15/6	1.0
GKH30K3CI		0.61	5/6	
GFH36K3CI		5.05	5/6	1.0
GTH36K3CI		1.52	3.15/6	
GKH36K3CI		0.61	5/6	1.0
GFH42K3CI		5.05	5/6	
GTH42K3CI		1.52	3.15/6	1.0
GKH42K3CI		0.61	5/6	

Model	Power Supply	Fan Motor FLA	Fuse/ Breaker Capacity	Min. Power Supply Cord
	V,Ph,Hz	A	A	mm ²
GFH48K3CI	220-240 1, 50	5.05	5/6	1.0
GTH48K3CI		2.53		
GFH60K3CI		3.33	5/6	1.0
GTH60K3CI		2.53		

Notes:
 RLA:Rated load amperes
 LRA:Locked rotor amperes
 FLA:Full load current
 Fuse: On the main board

4 PIPING DIAGRAM

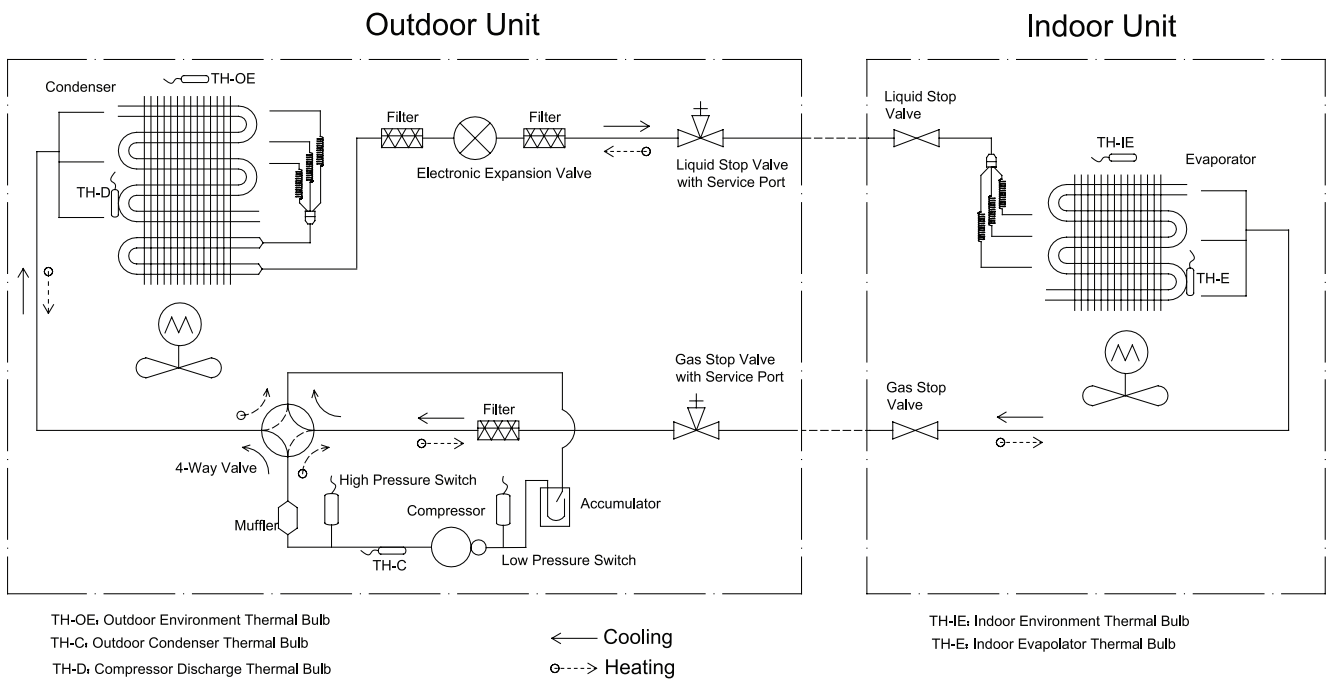

TH-OE: Outdoor Environment Thermal Bulb
 TH-C: Outdoor Condenser Thermal Bulb
 TH-D: Compressor Discharge Thermal Bulb

TH-IE: Indoor Environment Thermal Bulb
 TH-E: Indoor Evaporator Thermal Bulb

← Cooling
 ○---> Heating

Note:
 1.it is just a schematic diagram and some parts may differ from the real objects inside the unit.
 2.The throttling device for units 09K and 12K is the capillary rather than the electronic expansion valve.

CONTROL

CONTROL

1 OPERATION FLOWCHART

1.1 Cooling/Dry Operation

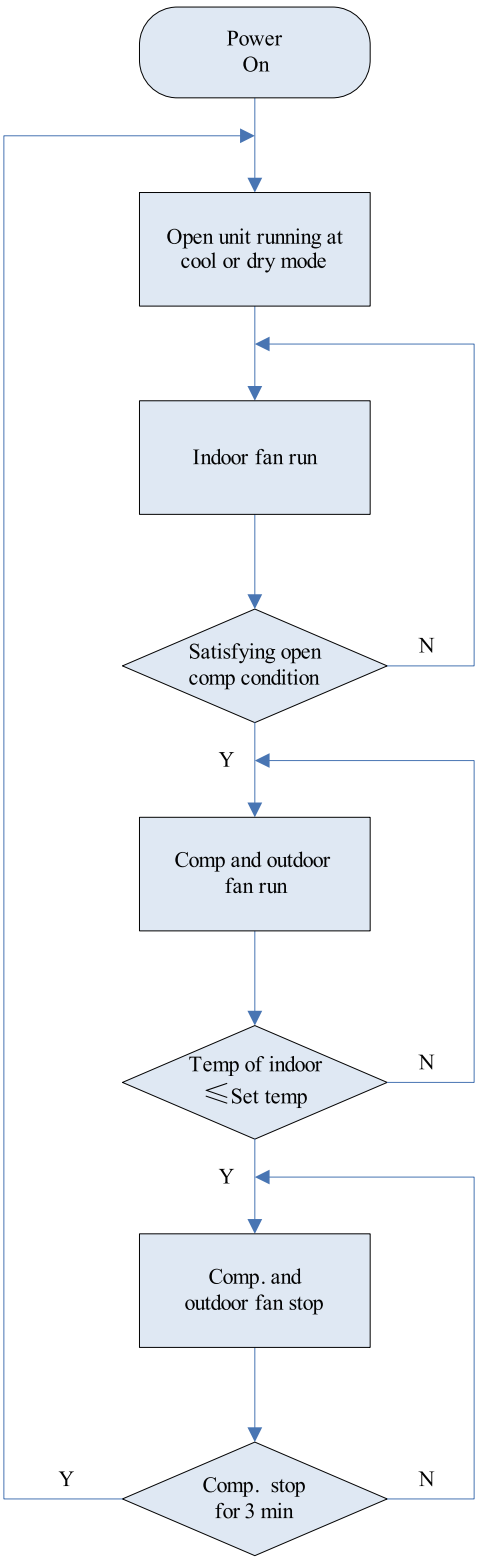

1.2 Heating Operation

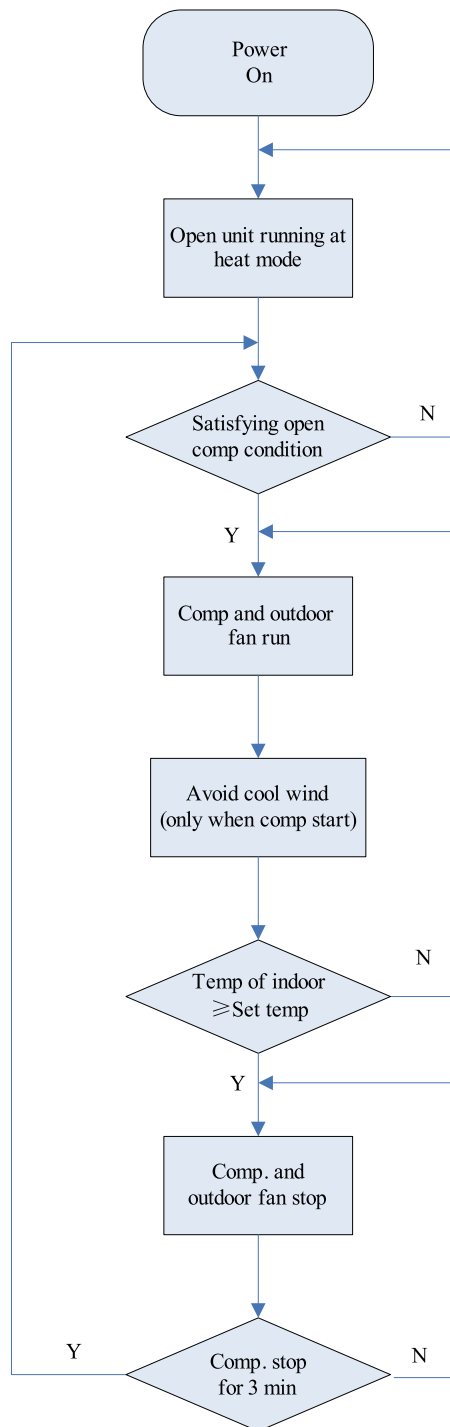

2 WIRELESS REMOTE CONTROLLER

2.1 Operation View

2.1.1 Controller-Duct Type

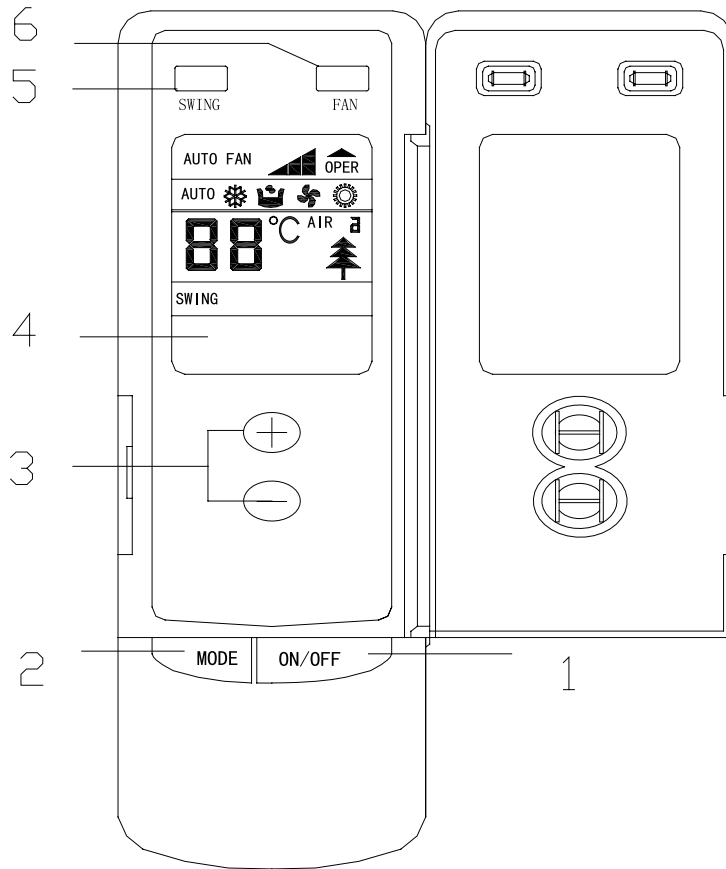

NO.	Name	Function description
1	ON/OFF button	Press the button to set turning on/off the unit.
2	Mode button	Press the button to select the mode, cooling , heating , fan or auto mode.
3	Increase/Decrease button	Press this button to increase/decrease the setup temp.
4	LCD Screen	Display the status of remote information.
5	Swing button	Press this button set swing function.
6	Fan speed button	Press this button to set fan speed.

2.1.2 Controller-Cassette Type and Ceiling Type

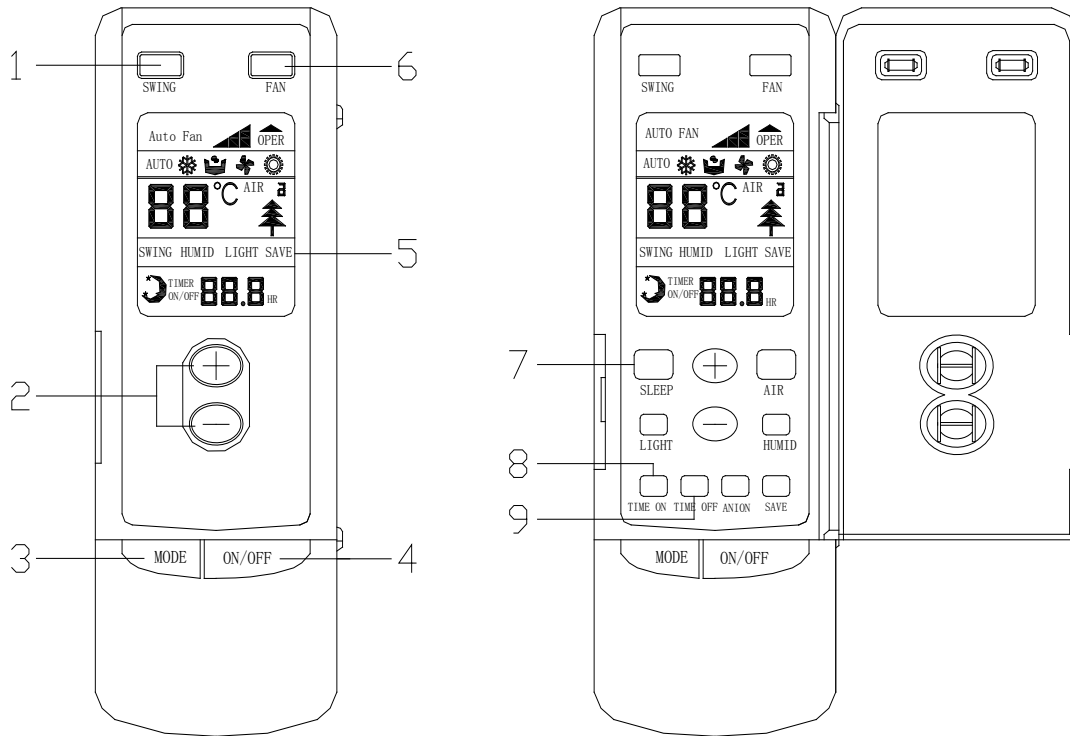

NO.	Name	Function description
1	Swing button	Press this button to set swing function.
2	Increase/Decrease button	Press this button to increase/decrease the setup temp.
3	Mode button	Press the button to select the mode, cooling , heating , fan or auto mode.
4	ON/OFF button	Press the button to set start or close unit.
5	LCD Screen	Display the status of remote information.
6	Fan speed button	Press this button to set fan speed.
7	Sleep button	Press the button to set sleep function.
8	Time on	Press the button to set time on function.
9	Time off	Press the button to set time off function.

3.2 Display View

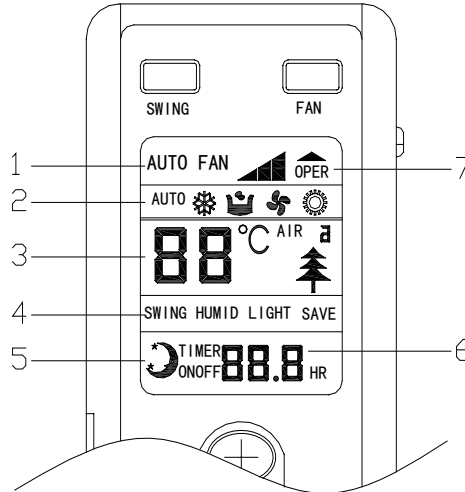

No.	Display	Function description
1	Fan Speed	AUTO FAN : auto fan speed; : low fan speed, : middle fan speed; : high fan speed.
2	Run Mode	AUTO : Auto running; : Cool running. : Dry Running ; : Fan Running. : Heat running (Heat and Cool unit only)
3	Setup temp	Temperature value of setting
4	Swing function	Swing is on
5	Sleep mode	Sleep mode is on
6	Time value	Timing value of setting
7	OPER	The controller is on

3 WIRED REMOTE CONTROLLER

3.1 Operation View

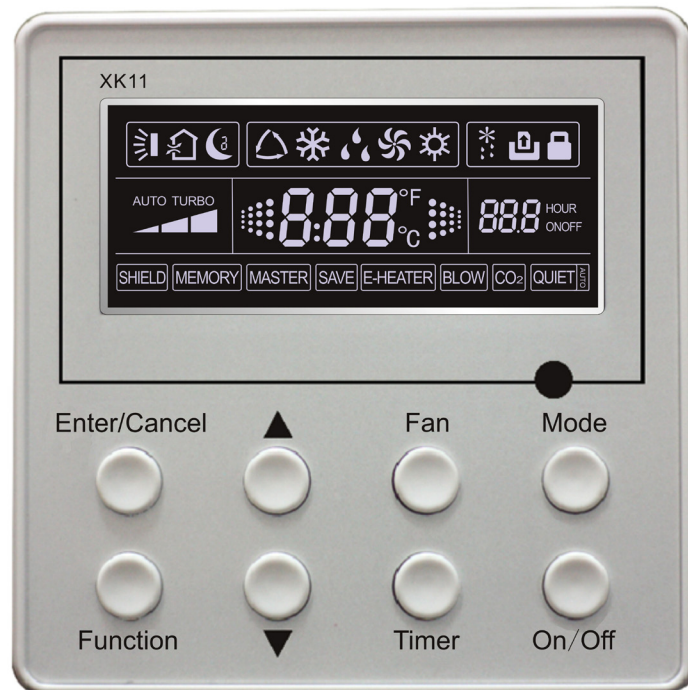

3.1.1 LCD Display of Wired Controller

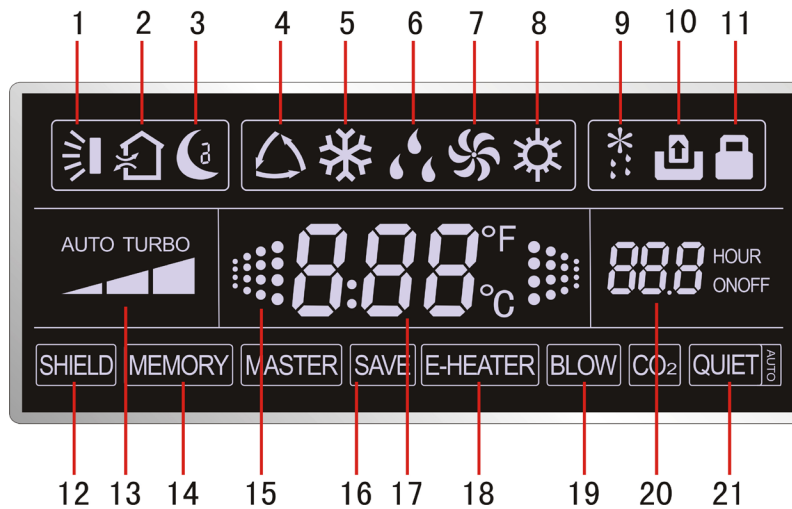

3.1.2 Instruction to LCD Display

No.	Description	Instruction to Displaying Contents
1	Swing	Swing function
2	Air	Air exchange function
3	Sleep	Sleeping states
4	Running mode	Each kind of running mode of indoor unit (auto mode)
5	Cooling	Cooling mode
6	Dry	Dry mode
7	Fan	Fan mode
8	Heating	Heating mode
9	Defrost	Defrosting state
10	Gate-control card*	Gate control
11	Lock	Lock state
12	Shield	Shielding state (buttons, temperature, on/off, mode or save is shielded by long-distance monitoring)
13	Turbo	Turbo function state
14	Memory	Memory state (Indoor unit resumes original setting state after power failure and then power recovery)
15	Twinkle	Flicking when unit is on without operation of buttons
16	Save	Energy-saving state
17	Temperature	Ambient/setting temperature value
18	E-Heater*	Mark that E-heater is allowed to turned on
19	Blow	Blow mark
20	Timer	Timer-displayed location
21	Quiet	Quiet state(two types: quiet and auto quiet)

Notes: The functions with * are reserved for other models and are not applicable for the models listed in this manual.

3.2 Buttons

3.2.1 Silk Screen of Buttons

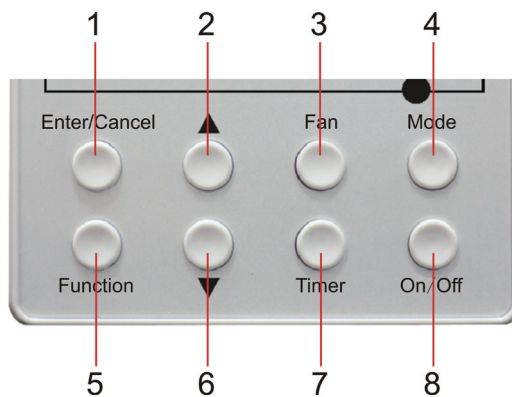

Fig. 4-2-1 Silk screen of butto

3.2.2 Instruction to Function of Buttons

No.	Description	Function of Button.
1	Enter/cancel	Function selection and canceling; Press it for 5s to enquiry the outdoor ambient temperature.
2	▲	Running temperature setting of indoor unit, range :16-30°C ; Timer setting, range:0.5-24hr; Switchover between quiet/auto quiet.
6	▼	
3	Fan	Setting of high/middle/low/auto fan speed.
4	Mode	Setting of cooling/heating/fan/dry mode of indoor unit.
5	Function	Switch over among these functions of air/sleep/turbo/save/e-heater/blow / quiet
7	Timer	Timer setting.
8	On/off	Turn on/off indoor unit.
4 Mode and 2 ▲	Memory function	Press Mode and ▲ for 5s under off state of the unit to enter/cancel key memory function (If memory is set, indoor unit will resume original setting state after power failure and then power recovery. If not, indoor unit is defaulted to be off after power recovery. Memory function is defaulted to be set before outgoing.).
2 ▲ and 6 ▼	Lock	Upon startup of the unit without malfunction or under off state of the unit, press ▲ ▼ key at the same time for 5s in to lock state. In this case, any other buttons won't respond the press. Repress ▲ ▼ key for 5s to quit lock state.
4 Mode and 5 Function	Enquiry and setting of address of wired controller	Under the off-state of the unit, press Mode/Function button for 5 seconds to set the address.
5 Function And 7Timer	Setting Ambient Temperature Sensor and three Grades of Speed for Indoor Fan	Under off state of the unit, press Function and Timer buttons continuously for 5s to go to the debugging menu. Press Mode button to adjust the setting items and ▲ or ▼ button to set the actual value.
5 Function and 6 ▼	Enquiry of Historical Errors	Continuously press Function and ▼ buttons for 5s to go to the enquiry state. In this state, press Enter/Cancel button to quit, or it will automatically quit after there is not any operation of button in 30min.

3.3 Installation of Wired Controller and Project Debugging

3.3.1 Installation of Wired Controller

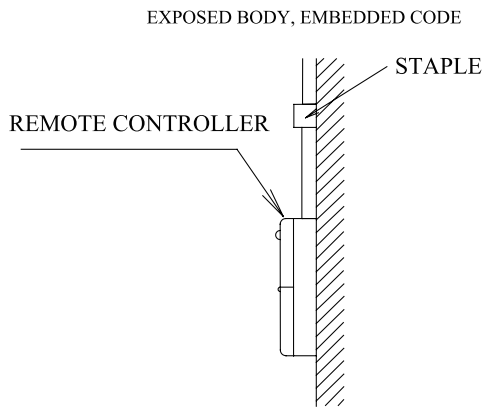

Fig.3.3.1: Fig.1 Surface mounting of Cable

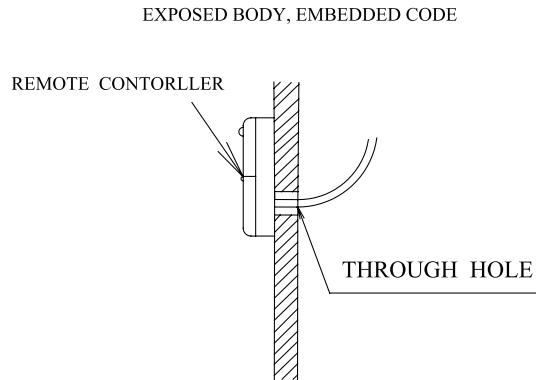

Fig.3.3.2: Fig.2 Concealed mounting of Cable

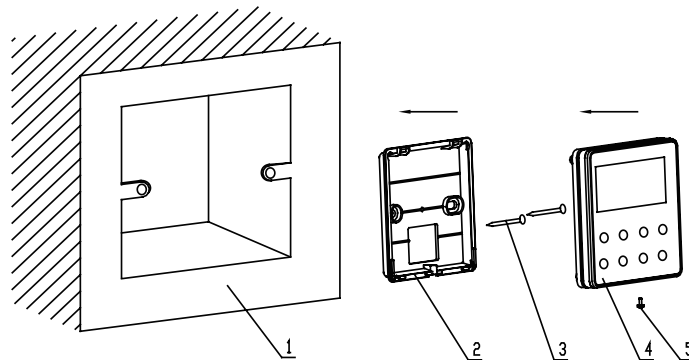

Fig.3.3.3: Sketch for Installation of Wired Controller

No.	1	2	3	4	5
Description	Socket's base box installed in the wall	Soleplate of controller	Screw M4×12	Front panel of controller	Screw ST2.9×6

Fig.3.3.3: Sketch for Installation of Wired Controller. Pay attention to the following items during installation of wired controller:

1. Cut off power supply of heavy-current wire embedded in mounting hole in the wall before installation. It is prohibited to perform the whole procedure with electricity.
2. Pull out 4-core twisted pair line in mounting hole and then make it through the rectangle hole at the back of controller's soleplate.
3. Joint the controller's soleplate on wall face and then fix it in mounting hole with screws M4×12.
4. Insert the 4-core twisted pair line through rectangle hole into controller's slot and buckle the front panel and soleplate of controller together.
5. At last, fix the controller's front panel and soleplate with screws ST2.9×6.

Caution:

During connection of wirings, pay special attention to the following items to avoid interference of electromagnetism to unit and even failure of it.

1. To ensure normal communication of the unit, signal line and wiring (communication) of wired controller should be separate from power cord and indoor/outdoor connection lines. The distance between them should be kept 20cm in min.

2. If the unit is installed at the place where there is interference of electromagnetism, signal line and wiring (communication) of wired controller must be shielded by twisted pair lines.

3.4 Error Display

If there is malfunction during running of the system, LCD will display error code at temperature–displayed location. Once there is more than one malfunction, error codes will be displayed circularly. If there are multiple circuit systems, the system number of failed system will be displayed before the colon (not for single system).

If malfunction occurs, turn off the unit and contact nearest dealer for help.

As shown in Fig.3.4.1, it means high pressure protection of system 2 under unit on.

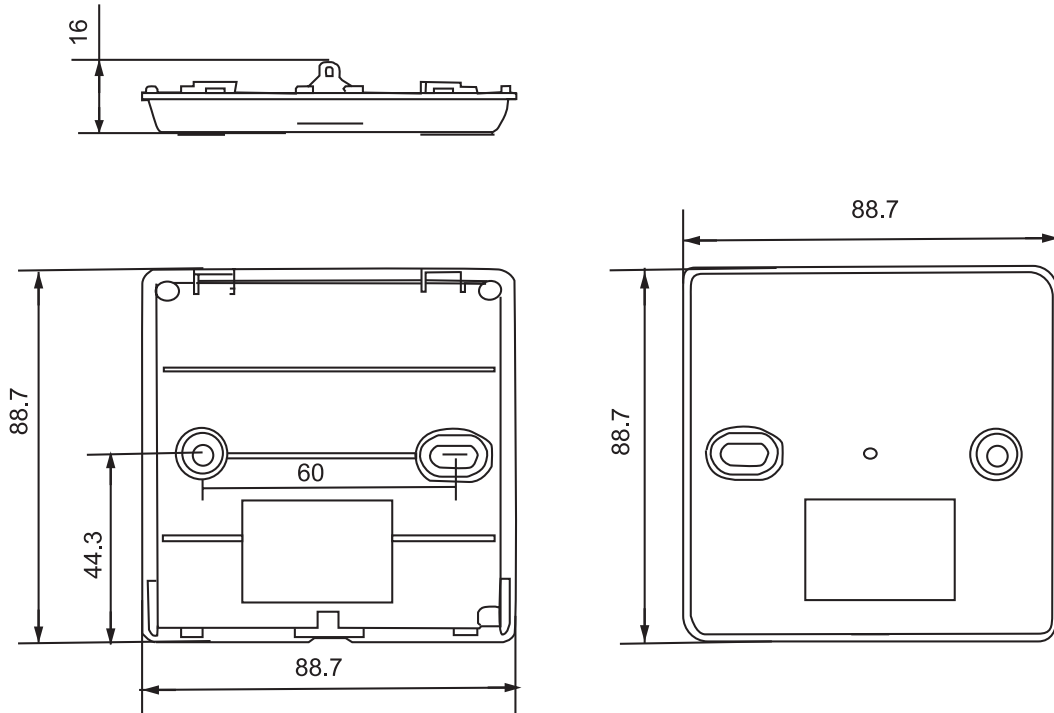

Fig.3.4.1

Error code meaning:

Error code	Malfunction
E1	High pressure protection of compressor
E2	Indoor anti-freezing protection
E3	Low pressure protection of compressor
E4	High discharge temperature protection of compressor
E5	Compressor overload or drive error
E6	Communication malfunction
E9	Water overflow protection
F0	Indoor unit ambient sensor malfunction at air return opening
F1	Evaporator sensor malfunction
F2	Condenser sensor malfunction
F3	Outdoor unit ambient temperature sensor mal
F4	Discharge temperature sensor malfunction
F5	Ambient sensor malfunction on the wired controller (or LED board)

3.5 Dimension



4 CENTRALIZED CONTROLLER

4.1 Centralized Controller-week timer

4.1.1 Function

Centralized Control and Week Timer Functions: The centralized controller and the weekly timer are integrated in the same wire controller. The system has both the centralized control and the week timing functions. Up to 16 sets of units can be controlled simultaneously by the centralized controller (weekly timer). The weekly timer has the function of invalidating the lower unit. The weekly timing function is able to realized four timing ON/OFF periods for any unit every day, so as to achieve fully automatic operation. No timing control can be set for holidays. On and off of every duct type unit can be done through the Timer On/Off of this WEEKLY TIMER it can not set other functions except on-off function of units.

4.1.2 Operation View

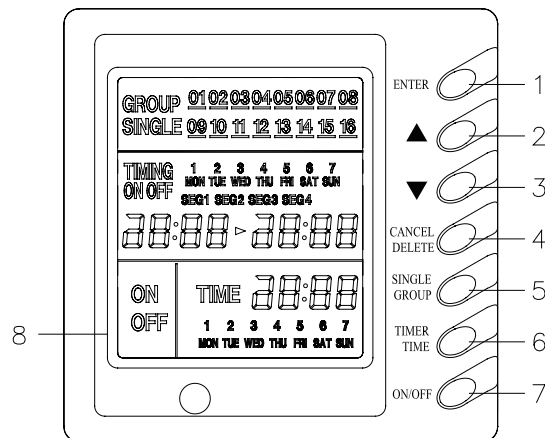

NO.	Name	Function description
1	ENTER button	Press the button to let setting validate.
2	Increasing button	Press “▲” and selected the unit or a certain day in one week or specific value. Press “▲” can set week part of time.
3	Decreasing button	Press “▼” and selected the unit or a certain day in one week or specific value. Press “▼” can set week part of time.
4	CANCEL/DELETE button	short-press “cancel/delete” to back to default page or last process, long-press “cancel/delete” to cancel timer of a certain time period in a certain day.
5	SINGLELE/GROUP button	short-press “single/group” to enter single control setting. “SINGLE” displayed. long-press “single/group” to enter group control setting. “GROUP” displayed
6	TIMER/TIME button	Short-press “timer/time” to enter timer setting. Long-press “timer/time” under default page can begin time setting.
7	On/off button	Press the button to set start or close the unit.
8	LCD display	Display unit information.

4.1.3 Display View

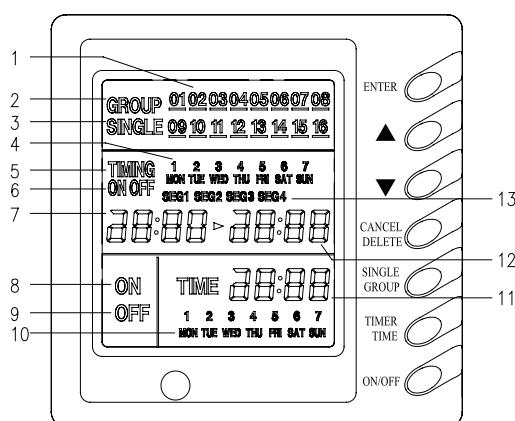

NO.	Name	Function description
1	Unit's no. displays	Display unit's numbers
2	Group control displays	when group controls, it will display
3	Single control displays	when single unit controls, it will display
4	Timer time in week displays	Display time in week
5	Timer displays	Display time
6	timer state displays	“on”: when set unit on, “on” will display; “off”: when set unit off, “off” will display;
7	timer on time displays	Display starts time
8	on control displays	When set unit or group on, it will display,
9	off control displays	When set unit or group off, it will display,
10	present time in week display	Display present time of week.
11	present time in Hr:Min displays	Display time of hour and minute now
12	timer off time displays	Display over time
13	timer period displays	Set to different time segment

Note:

Please read corresponding manual of weekly timer controller to be familiar with it.

4.1.4 Dimensions

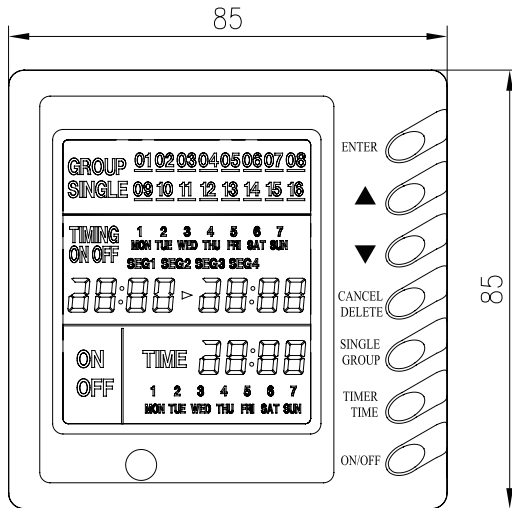

4.2 Smart Zone Controller

4.2.1 Function

The smart zone controller can directly control up to 16 sets of indoor units in a control network and is available to check the running status of any unit through the LCD, including running mode, timer, fan speed, central control and shielding setting etc.

4.2.2 Outline Drawing of Press Buttons



4.2.3 Functions of Press Buttons

Table 2: Functions of Press Buttons

No.	Name	Function Description
1	Mode	It is used for the switchover among different modes.
2	Fan	It is used to set the fan speed, <i>high</i> , <i>medium</i> , <i>low</i> or <i>auto</i> .
3	On/Off	It is used to set the on/off status of the indoor unit.

4	▲	1. Under the single/centralized control status:It is used to set the running temperature of the indoor unit with max.30°C anmin.16°C;
5	▼	2. Under the timing setting status:It is used to set the timing period with max.24 hours and min.0 hour; 3. Under the clock setting status: it is used to set the hour (max.:23, min.: 0) and minute (max.:59, min.: 0) of the clock.
6	Mon 1/9	It is used for the switchover between unit 1 and unit 9; Under the timing or clock setting status, it indicates Monday.
7	Tue 2/10	It is used for the switchover between unit 2 and unit 10; Under the timing or clock setting status, it indicates Tuesday.
8	Wed 3/11	It is used for the switchover between unit 3 and unit 11; Under the timing or clock setting status, it indicates Wednesday.
9	Thu 4/12	It is used for the switchover between unit 4and unit 12; Under the timing or clock setting status, it indicates Thursday.
10	Fri 5/13	It is used for the switchover between unit 5and unit 13; Under the timing or clock setting status, it indicates Friday.
11	Sat 6/14	It is used for the switchover between unit 6 and unit 14; Under the timing or clock setting status, it indicates Saturday.
12	Sun 7/15	It is used for the switchover between unit 7 and unit 15; Under the timing or clock setting status, it indicates Sunday.
13	8/16	It is used for the switchover between unit 8 and unit 16.
14	Timer/Time	It is used to set the timing or on/off time of the selected indoor unit as well as to set the clock of the system.
15	Central	It is used for the switchover between single and centralized control modes.
16	Shield	It is used to deactivate some or all functions of a single or a group the indoor unit(s).
17	All on/off	It is used to start/stop all indoor units.

4.2.4 LCD of the Controller

4.2.4.1 Outline Drawing of the LCD

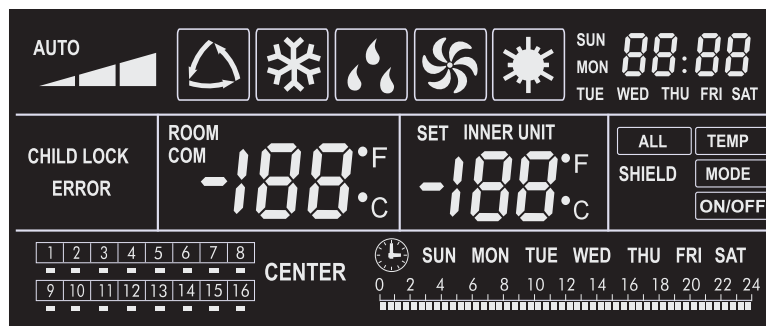

5.2.4.2 Introduction to Symbols on the LCD

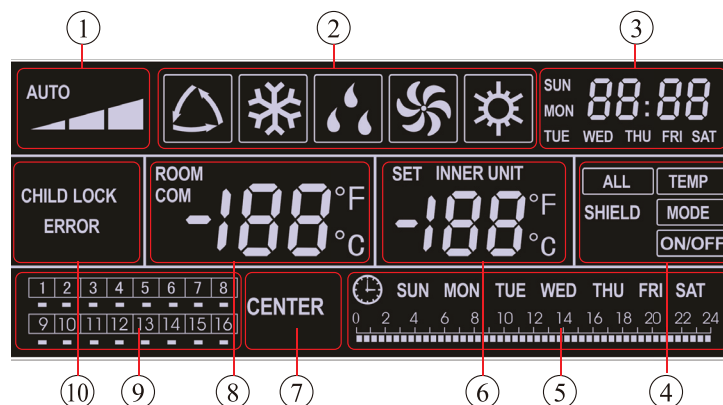
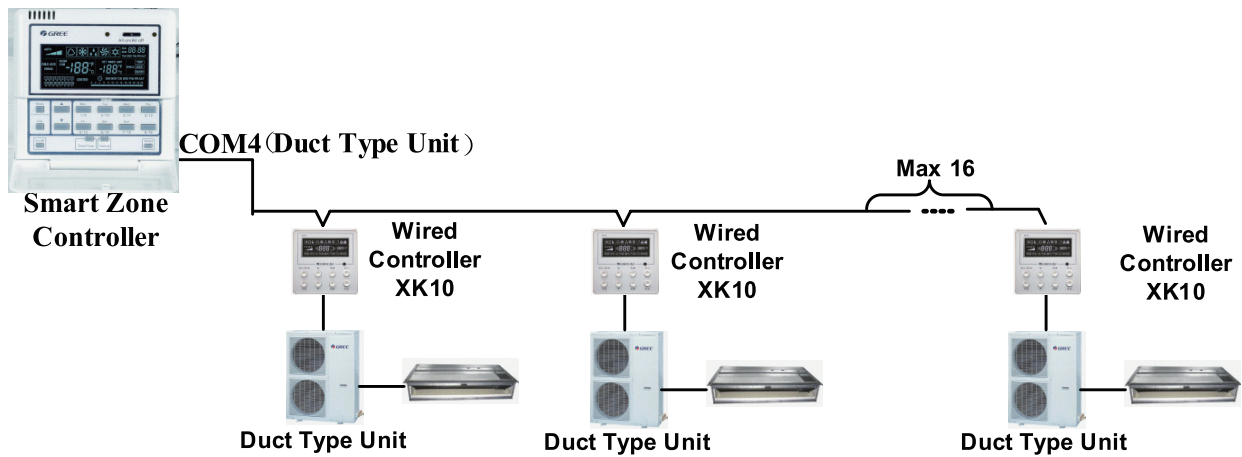

Table 1: Introduction to the Symbols on the LCD

No.	Name	Description
1	Fan speed	It displays the fan speed of the indoor unit, <i>high</i> , <i>medium</i> , <i>low</i> and <i>auto</i> .
2	Running mode	It displays the running mode of the indoor unit, <i>auto</i> , <i>cool</i> , <i>dry</i> , <i>fan</i> and <i>heat</i> .
3	System clock	It displays the current time (hour and minute) in 24-hour time system and also the week day.
4	Shield	It displays the shield status, "ALL", "TEMP", "MODE" and 'On/Off'.
5	Weekly timer	It displays the timing period (unit: 0.5 hour) which will circulate every week.
6	Set temperature Indoor unit code	It displays the set temperature, indoor unit code (01-16), and symbols of Celsius and Fahrenheit scale.
7	Control mode	It displays "CENTER" under the centralized control mode and no display under the single control mode.
8	Ambient temperature Serial port	It displays the ambient temperature, serial port as well as symbols of Celsius and Fahrenheit scale.
9	Indoor unit code On/off status	Numbers indicate the indoor unit codes which will be displayed when the corresponding indoor unit is online; "□" indicates the on/off status of the indoor unit, its flashing for "on" or else for "off"
10	Error Child lock	It displays the error codes when some error(s) arises and also "CHILD LOCK" when this function is activated.

4.2.4.3 Network Topology

Network Connection of the Smart Zone Controller



4.2.4.4 Dimensions

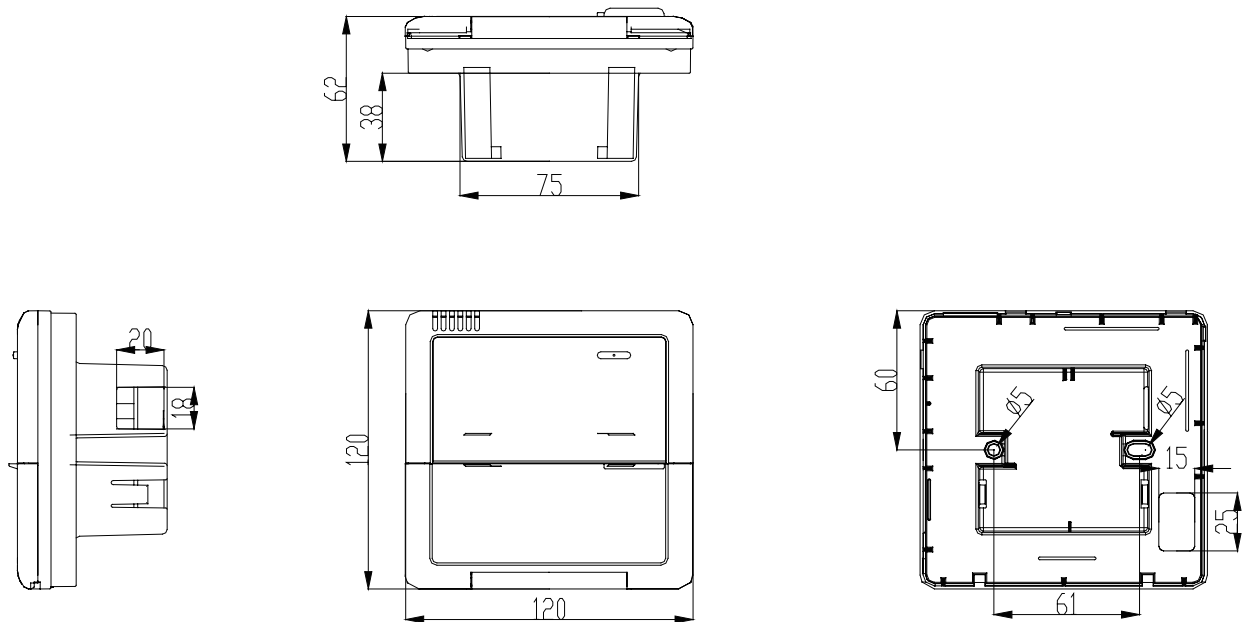

INSTALLATION

INSTALLATION

1 INDOOR UNIT INSTALLATION

1.1 Installation of Duct Type

1.1.1 Before Installation

- After receiving the machine, please check for any transport damage. If finding any surface or internal damage, please immediately report to the transport company or equipment company in writing.
- After receiving the machine, please check the unit and accessories in reference to the packing list. Ensure that the model is correct and the machine is in good condition. Please also check if the specification and quantity of accessory parts are correct.
- Determine the correct handling route and methods, thus to avoid damaging the unit or causing possible hazard. For the sake of protection and safety, it is suggested to move the unit with the packaging box. Even though it is not permitted to do like this under special occasions, do not remove the packaging box, thus to avoid loosening or falling during handling.
- Confirm if the installing foundation is solid. When this unit is to be installed on the metal section of the building, make sure that the electrical insulation must comply with applicable standards.
- Ensure that the place of installation is far from the area where the inflammable or explosive substances are stored, thus to avoid possible explosion or fire due to leakage.

1.1.2 Installation Site

- Ensure the top hanging piece has strong strength to withstand the weight of the unit.
- The drainage pipe has convenient flow of water.
- There is no obstacle blocking the return air inlet and exhaust outlet, so as to ensure sound air circulation.
- The installation spaces required by the drawing must be ensured, so as to provide enough space for the service and maintenance.
- The installation site must be far away from heat source, leakage of inflammable gas or smoke.
- The indoor unit is of ceiling mount (indoor unit is hidden inside the ceiling).
- The indoor and outdoor units, the power cable and the connecting electrical lines must be at least 1 meter from any TV set or radio. This is to avoid image interference or noise of the TV set or radio. (Even if the distance is 1 meter, noise can also exist if there is strong electric wave.)

1.1.3 Caution for Installation

- Generally, the unit is installed indoor on ceiling. For ceiling mounting, ensure that the hangers on ceiling have adequate strength to support the weight of the unit.
- To meet the noise and vibration requirements, the unit shall be installed by using rubber pad (thickness $\geq 20\text{mm}$) and rubber connector.
- Insert a M10 expansion bolt into the hole. Drive a nail into the bolt. Refer to the profile dimensions drawing of the indoor unit for the distance between the holes. Refer to Figure 1 for the installation of the expansion bolt, as Figure 1-1-1 shows.

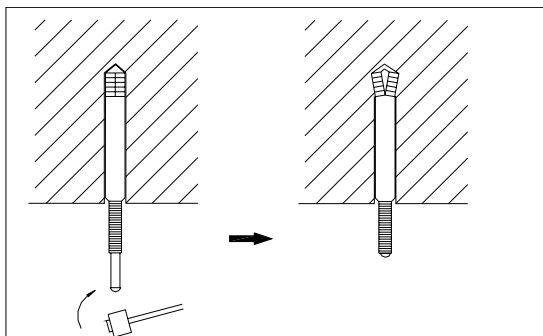

Figure 1-1-1

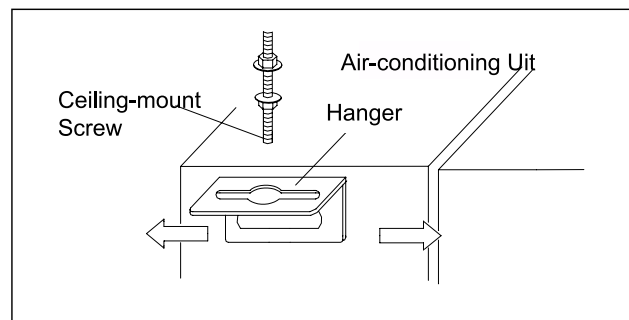

Figure 1-1-2

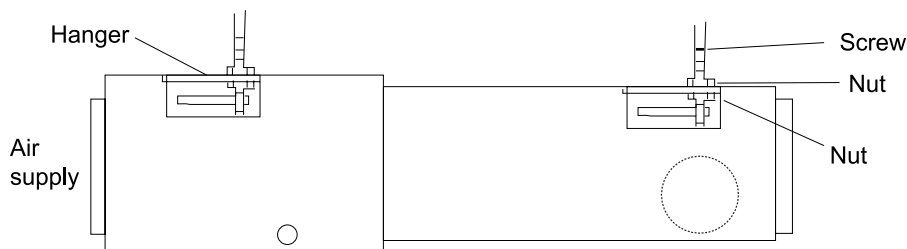

Figure 1-1-3

- d. Install the hanger onto the indoor unit as Figure 1-1-2 and Figure 1-1-3 shows.
- e. Install the indoor unit at the ceiling as Figure 1-1-5 shows.

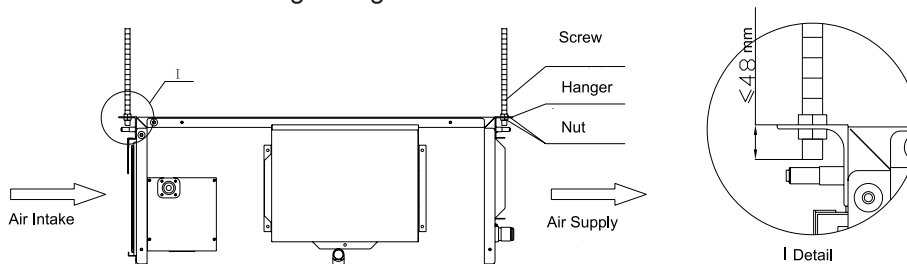

Figure 1-1-5

f. Precautions for unfavorable installation:

The preparation of all pipes (connecting pipes and drainage pipes) and cables (connecting lines of wire controller, indoor unit and outdoor unit) must be ready before the installation, so as to achieve smooth installation.

Drill an opening on the ceiling. Maybe it is required to support the ceiling to ensure the evenness of it and avoid the vibration of it. Consult with the user or a construction company for details.

In case the strength of ceiling is not enough, use angle iron sections to set up a beam support. Place the unit at the beam and fix it.

g. Level inspection of the indoor unit

After the indoor unit is installed, it is required to check the level of the whole unit. The unit must be placed horizontally, but the condensate pipe shall be installed obliquely, so as to facilitate the drainage of condensate.

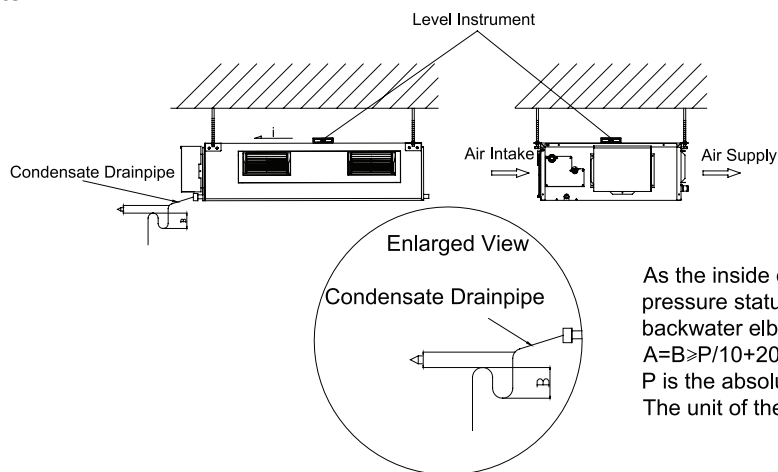
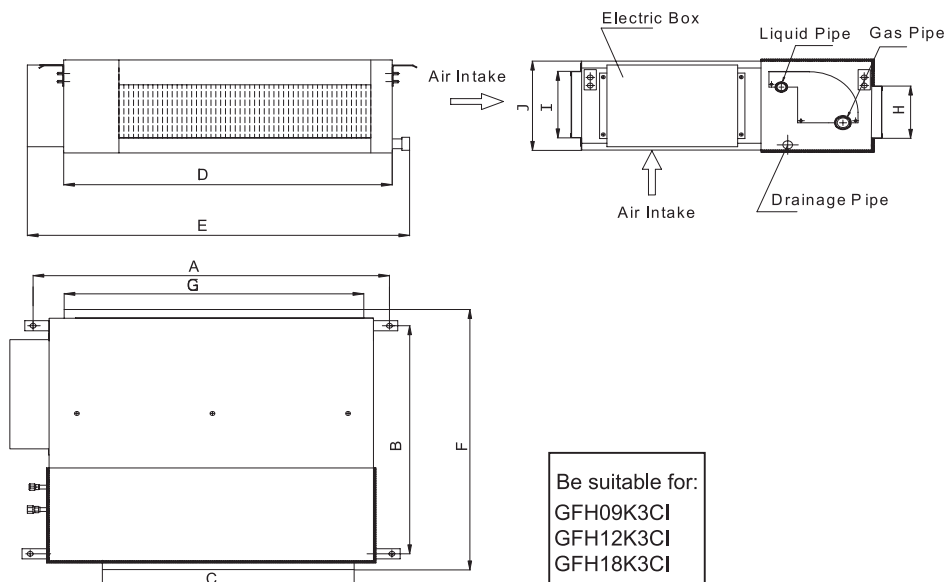

Figure 1-1-6

1.1.4 Dimension Data



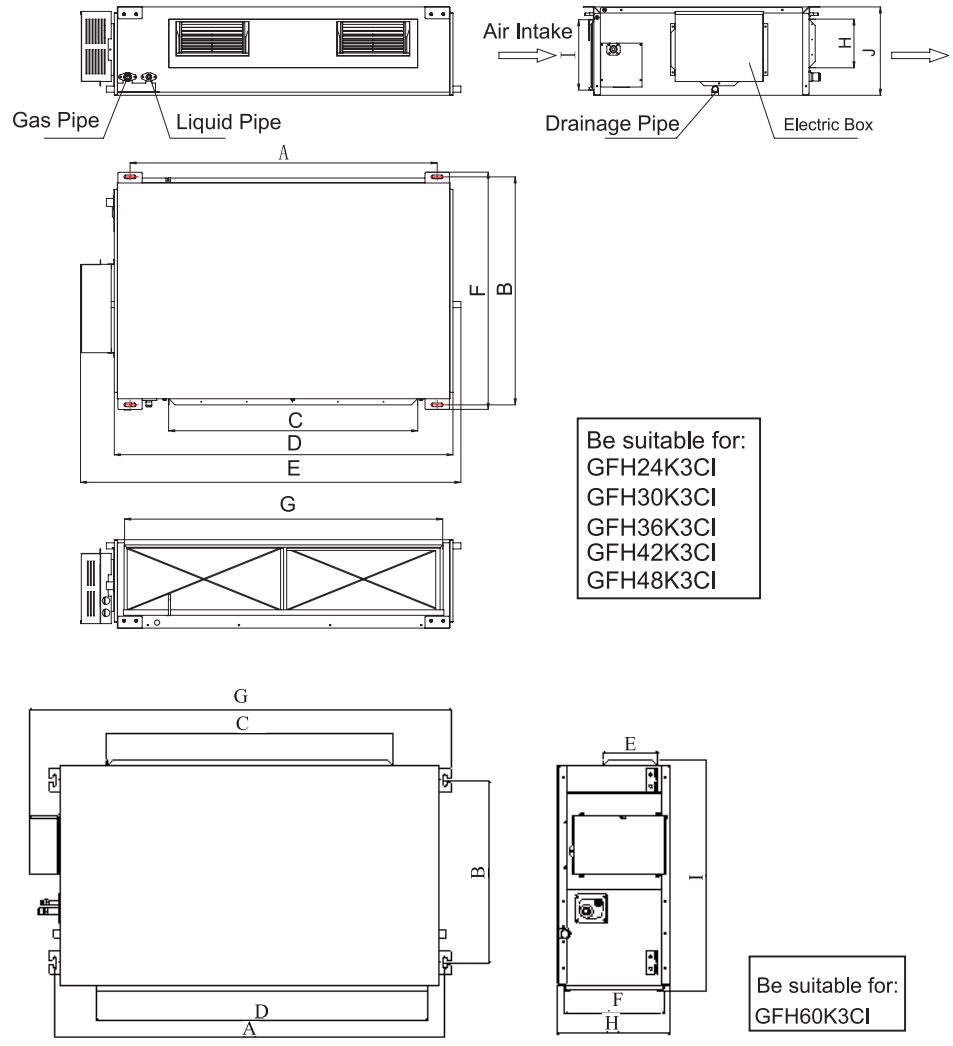

Figure 1-1-7

Unit:mm

Item / Model	A	B	C	D	E	F	G	H	I	J
GFH09K3CI	840	561	635	790	880	665	738	125	203	250
GFH12K3CI	932	430	738	892	980	721	738	125	203	266
GFH18K3CI	932	430	738	892	980	721	738	125	203	266
GFH24K3CI GFH30K3CI	1101	515	820	1159	1270	530	1002	160	235	268
GFH36K3CI GFH42K3CI	1011	748	820	1115	1226	775	979	160	231	290
GFH48K3CI	1015	788	820	1115	1226	815	979	160	261	330
GFH60K3CI	1353	632	992	1150	192	343	1463	385	799	--

Installation Accessories List for Duct-type Indoor Unit

Name & Shape	QTY	Notes
Installation and Operating Instructions	1	
Insulation materials for gas pipe	1	Used for gas pipe connector on indoor unit
Insulation materials for liquid pipe	1	Used for liquid pipe connector on indoor unit
Insulation materials for drainage pipe	2	Used for wrapping the condensate pipe and rubber plug.
Nut M8 with gasket	8	Use for fixing the hanger hook
	4	4 sets, used for ceiling mounting of the indoor unit
Nut and spring gasket	4	
Hook	4	Used for ceiling mounting of the indoor unit
Strap	4 or 8 pcs	4 pcs for 18KBtu/h unit and 8 pcs for others
Wired controller	1	
Remote controller	1	
Battery	2	
Flexibile pipe	0.2 or 4 pcs	0 pc for 18 KBtu/h unit; 2 pcs for 22.5,27KBtu/h unit; and 4 pcs for 36-45KBtu/h unit
Power cord	1 – 2 pcs	2 pcs for36-45 KBtu/h unit and 1 pc for others
Connection wire		

1.1.5 Installation Clearance Data

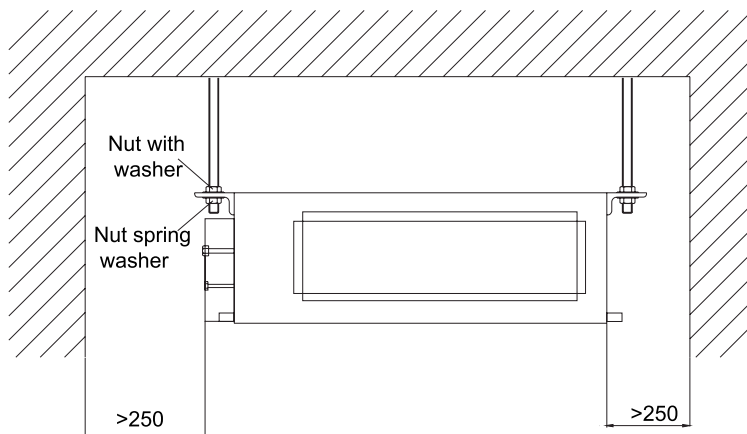

Be suitable for:
GFH09K3CI
GFH12K3CI
GFH18K3CI

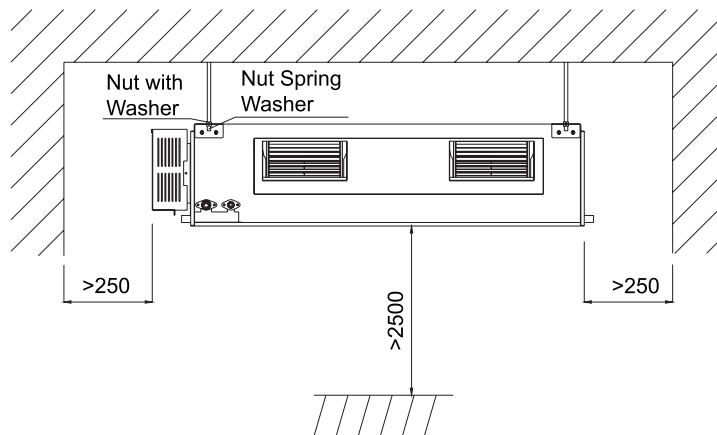

Be suitable for:
GFH24K3CI
GFH30K3CI
GFH36K3CI
GFH42K3CI
GFH48K3CI

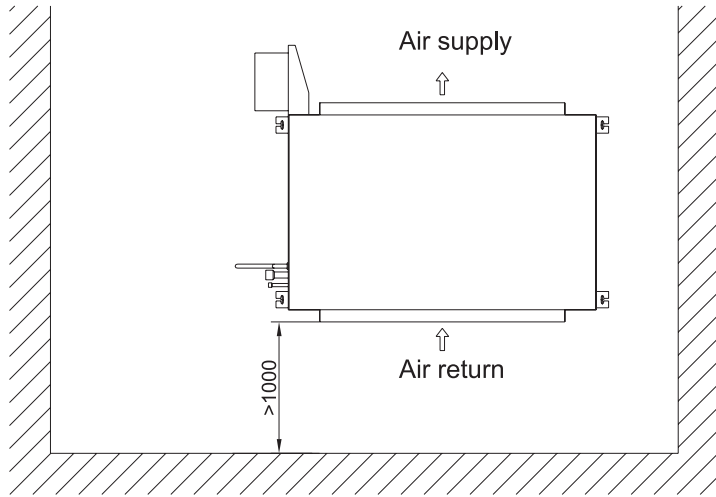
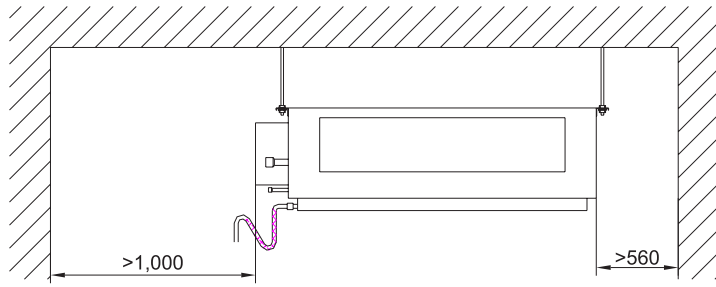

Be suitable for:
GFH60K3CI

Figure 1-1-8

Warning: The height of installation for the indoor unit should be 2.5m above.

1.1.6 Drain Piping Work

a. Installation of Drainage Pipeline

- A drainage outlet is located at both the left and right sides of the indoor unit. After selecting one drainage outlet, the other outlet shall be blocked by rubber plug. Bundle the blocked outlet with string to avoid leakage, and also use thermal insulation materials to wrap the blocked outlet.
- When shipped out from factory, both the Drainage outlets are blocked by rubber plugs.
- When connecting the drainage pipe with the unit, do not apply excessive force to the pipeline at the side of the unit. The fixing position of the pipeline shall be near the unit.
- Purchase general-purpose hard PVC pipe locally to be used as the drainage pipeline. When carrying out connection, place the end of the PVC pipeline into the drainage hole. Use flexible drainage tube and tighten it with thread loop. Never use adhesive to connect the drainage hole and the flexible drainage tube. (As shown in Figure 1-1-9)
- When the laid drainage pipe is used for multiple units, the common pipe shall be about 100mm lower than the drainage outlet of each set of unit. A pipe with thicker wall shall be used for such purpose.

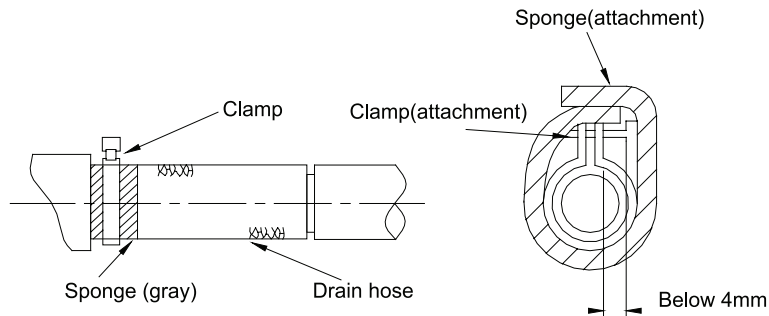

Figure 1-1-9

b. Testing of Drainage System

After the electrical installation is completed, carry out the testing of the drainage system. During the test, check if the water correctly flows through the pipelines. Carefully observe the joints to ensure that there is no leakage. If the unit is to be installed in a new house, carry out testing before decorating the ceiling.

c. Matters of Attention

- The joint of Drainage Pipeline must not have leakage.
- The Drainage Pipeline shall be installed with an inclining angel of 5~10°, so as to facilitate the drainage of condensate. The joints of the Drainage Pipeline must be covered by thermal insulation materials to avoid generation of exterior condensate. (As shown in Figure 1-1-10)

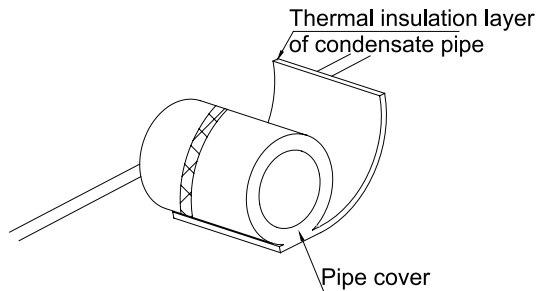

Figure 1-1-10

1.1.7 Installation of air duct and round duct for duct-type unit

Caution:

- The supply air duct, the return air duct and the fresh air duct must be covered with a layer of thermal insulation, so as to avoid thermal leakage and condensation. Firstly apply liquid nail on the duct, and then attach the thermal insulation cotton with a layer of tinfoil. Use the liquid nail cover to fix it. Lastly use tinfoil adhesive tape to carefully seal the joints; other good thermal insulation materials can also be used.
- The supply air duct and the return air duct shall be fixed to the prefabricated boards of the ceiling by using iron supports. The joints of the pipes must be sealed by glue so as to avoid leakage.
- The design and installation of air duct must be in conformity with the relevant state engineering criteria.
- The edge of the return air duct must be at least 150mm away from the wall. The return air inlet must be covered with filter.
- Silencing and shock absorption shall be considered in the design and installation of the air duct. Additionally, the noise source must be far away from where people stay. The return air inlet shall not be located above the place where users stay (offices and rest places, etc.).

a. Installation of supply air duct

- Installation of rectangular air duct, as shown in Fig. 1-1-11

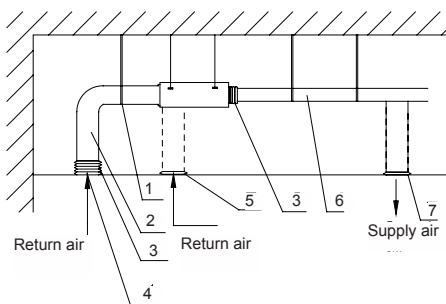

Figure 1-1-11

Serial No.	Name	Serial No.	Name
1	Hanger rod	5	Filter
2	Return air duct	6	Main supply air duct
3	Canvas air duct	7	Supply air outlet
4	Return air inlet		

- Installation of round air duct, as shown in Fig. 1-1-12

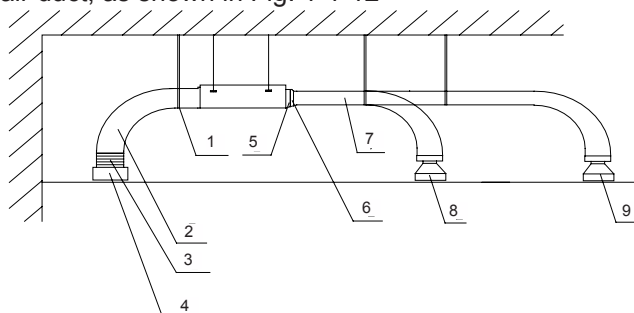

Figure 1-1-12

Number	Name	Number	Name
1	Hanger rod	6	Transition air duct
2	Return air duct	7	Supply air duct
3	Canvas air duct	8	Diffuser
4	Return air louver	9	Diffuser joint
5	Supply air outlet		

Notes:

The above two figures only indicate the installation of back return return air inlet. Down return air inlet may also be used as needed for actual installation. The installation method is similar to that of back return air inlet. Among all the Supply air outlets, at least one shall be kept open. Round air duct can also be used, in which a thermally insulated round hose is used to supply the air to the room. Both the supply air duct and return air duct shall be thermally insulated.

b. Installation of fresh air duct (Limited to excessive residual pressure unit with a cooling capacity over 6000W)

- Cut off the fresh air baffle when connecting the fresh air duct, as shown in Fig. 1-1-13(a). If not using the fresh air duct, please use sponge to seal the fresh air baffle clearance.
- Mount the round flange for connection of the fresh air duct, as shown in Fig. 1-1-14(b).
- Both the air duct and round flange shall be well sealed and thermally insulated.
- The fresh air shall be the air that is filtered.

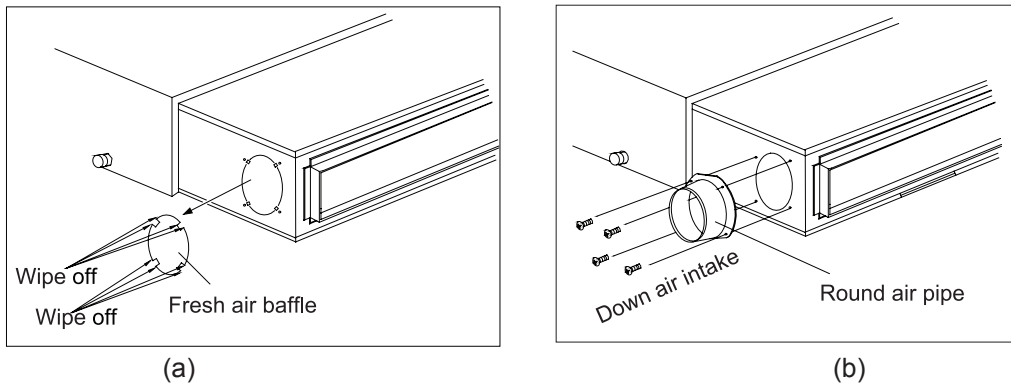

Figure 1-1-13

c. Installation of return air duct

The square flange is mounted on rear section when it is shipped. The return air inlet cover plate is mounted beneath, as shown in Fig. 1-1-14.

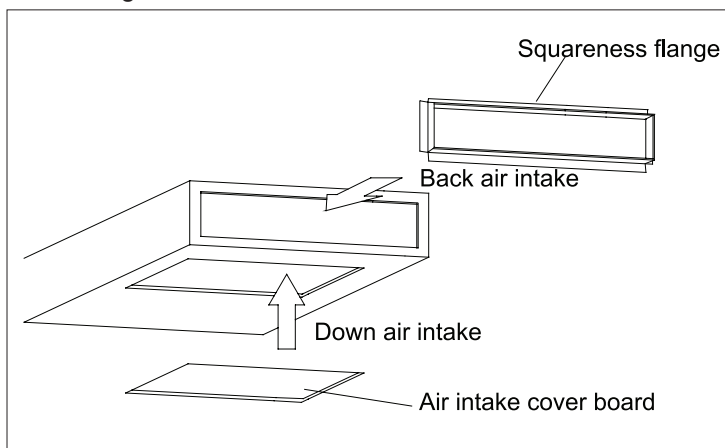

Figure 1-1-14

- If down return air inlet is to be used, just change the position between square flange and cover plate of return air inlet.
- Rivet the return air duct to the return air inlet of indoor unit and connect another end to return air window. For free adjustment of the height, you may fabricate a section of canvas air duct and reinforce with 8# iron wire in folded form. You may select the installation methods in overall consideration of the building and maintenance conditions, as shown in Fig. 1-1-15.

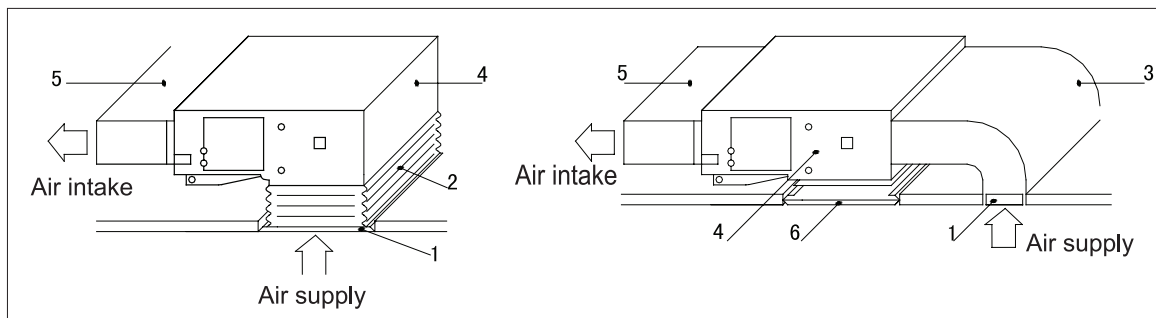

Figure 1-1-15

Number	Name	Number	Name
1	Return air window (with filter)	4	
2	Canvas air duct	5	Supply air duct
3	Return air duct	6	Test grill

d. Installation of round Supply air outlet

(Installation sketch for round supply air outlet)

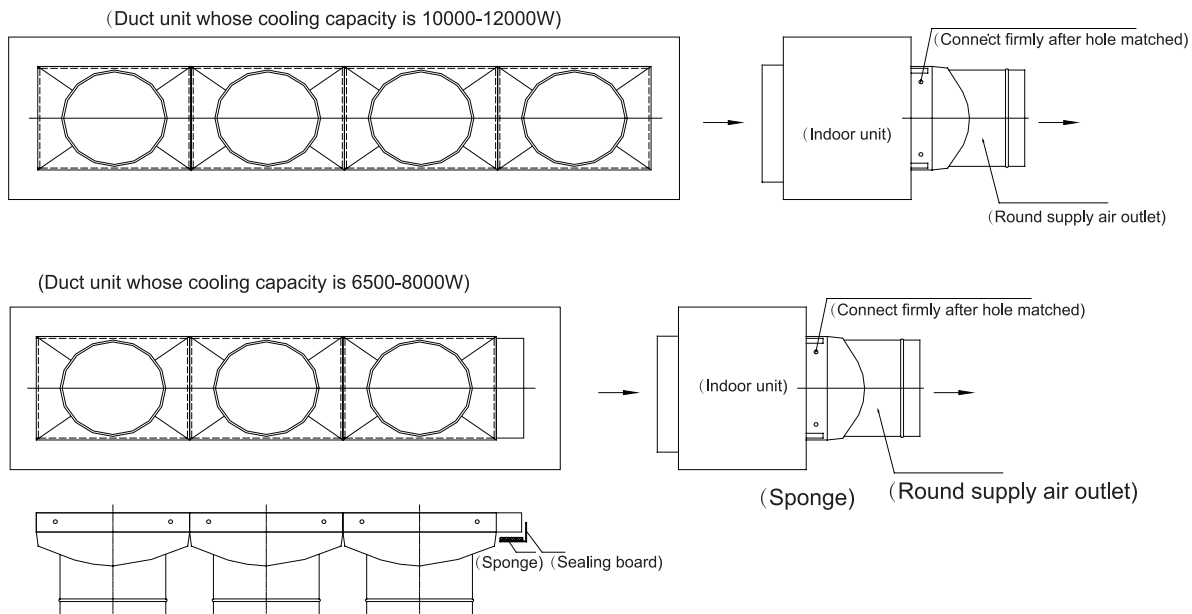

Figure 1-1-16

1.2 Installation of Ceiling Type

1.2.1 Before Installation

- After receiving the machine, please check for any transport damage. If finding any surface or internal damage, please immediately report to the transport company or equipment company in writing.
- After receiving the machine, please check the unit and accessories in reference to the packing list. Ensure that the model is correct and the machine is in good condition. Please also check if the specification and quantity of accessory parts are correct.
- Determine the correct handling route and methods, thus to avoid damaging the unit or causing possible hazard. For the sake of protection and safety, it is suggested to move the unit with the packaging box. Even though it is not permitted to do like this under special occasions, do not remove the packaging box, thus to avoid loosening or falling during handling.
- Confirm if the installing foundation is solid. When this unit is to be installed on the metal section of the building, make sure that the electrical insulation must comply with applicable standards.
- Ensure that the place of installation is far from the area where the inflammable or explosive substances are stored, thus to avoid possible explosion or fire due to leakage.

1.2.2 Installation Site

- Such a place where cool air can be distributed throughout the room.

- Such a place where condensation water is easily drained out.
- Such a place that can handle the weight of indoor unit.
- Such a place which has easy access for maintenance.
- Such a place where is permitting easy connection with the outdoor unit.
- Such a place where is 1m or more away from other electric appliances such as television, audio device, etc.
- Avoid a location where there is heat source, high humidity or inflammable gas.
- Do not use the unit in the immediate surroundings of a laundry, a bath, a shower or a swimming pool.
- Be sure that the installation conforms to the installation dimension diagram.
- The space around the unit is adequate for ventilation.

1.2.3 Caution for Installation

- Adjust the distance from the unit to the ceiling slab beforehand (Refer to Figure 1-2-1).
- Fix the hanger bracket to the suspension bolt (Refer to Figure 1-2-2).
- Make sure that extended suspension bolt from the ceiling stays inside the arrowed position. Readjust the hanger bracket when it is outside the arrowed position. (Refer to Figure 1-2-3)
- Suspension bolt stays inside the cap of indoor unit .Never remove the cap. Lift the unit and slide forward unit the dent. (Refer to Figure 1-2-4)
- Screw tightly both hanger bracket setting bolts (M8) (Refer to Figure 1-2-2)
- Screw tightly both hanger bracket fixing bolts (M6) to prevent the movement of the indoor unit. (Refer to Figure 1-2-2)
- Adjust the height by turning the nut with a spanner. Insert the spanner from the hanger bracket opening. (Refer to Figure 1-2-5)

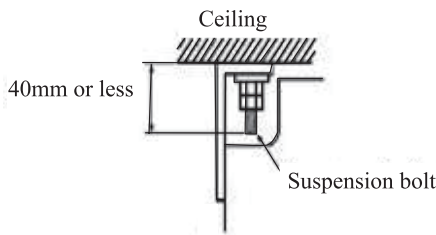

Figure 1-2-1 Hanger bracket

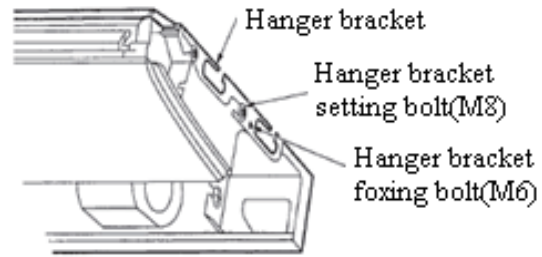

Figure 1-2-2

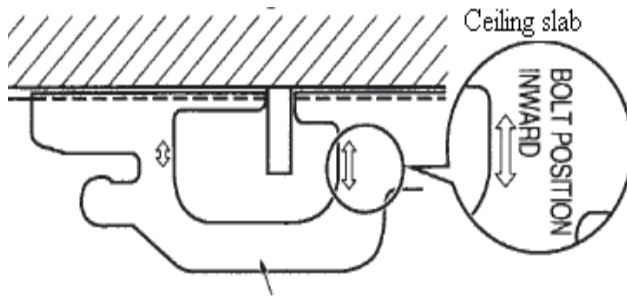

Figure 1-2-3 Hanger bracket

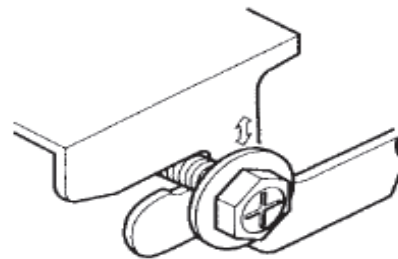

Figure 1-2-4

In case of hanging:

It is possible to install using inward facing hanger bracket by not removing the brackets from the indoor unit. (Refer to Figure 1-2-6) Be sure to use only the specified accessories and parts for installation work.

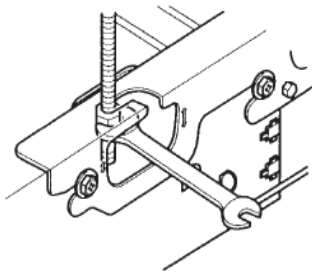

Figure 1-2-5

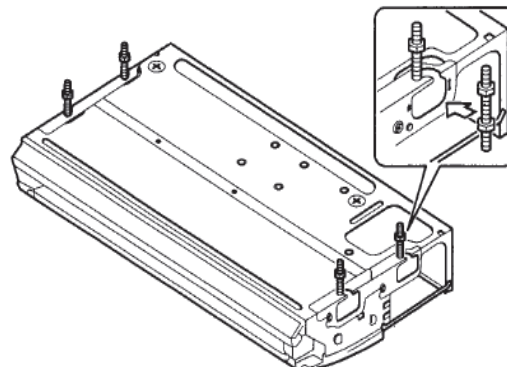

Figure 1-2-6

1.2.4 Dimension Data

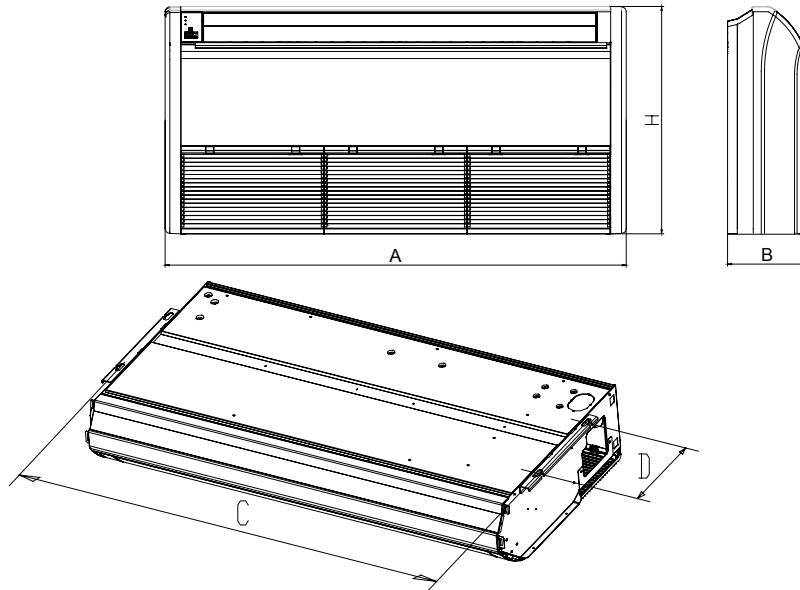

Figure 1-2-7

Unit: mm

Model	A	B	C	H	E
GTH09K3CI GTH12K3CI GTH18K3CI GTH24K3CI	1220	225	1158	700	280
GTH30K3CI GTH36K3CI GTH42K3CI	1420	245	1354	700	280
GTH48K3CI GTH60K3CI	1700	245	1634	700	280

1.2.5 Installation Clearance Data

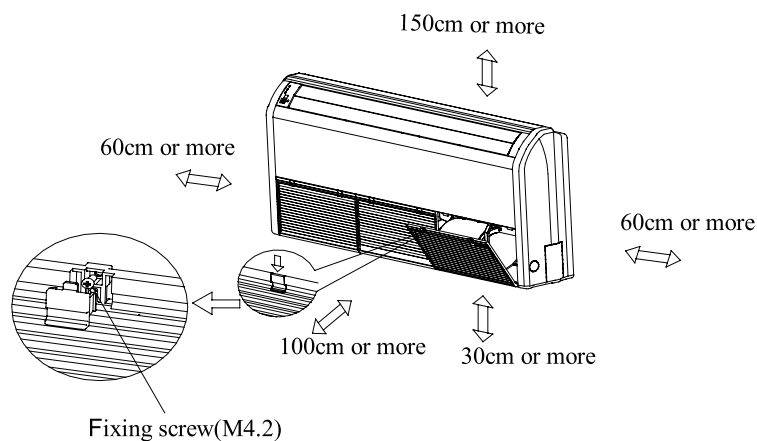

Figure 1-2-8

1.2.6 Drain Piping Work

a. Installation of Drainage Pipeline

- A Drainage outlet is located at both the left and right sides of the indoor unit. After selecting one Drainage outlet, the other outlet shall be blocked by rubber plug. Bundle the blocked outlet with string to avoid leakage, and also use thermal insulation materials to wrap the blocked outlet.
- When shipped out from factory, both the Drainage outlets are blocked by rubber plugs.
- When connecting the drainage pipe with the unit, do not apply excessive force to the pipeline at the

side of the unit. The fixing position of the pipeline shall be near the unit.

- Purchase general-purpose hard PVC pipe locally to be used as the drainage pipeline. When carrying out connection, place the end of the PVC pipeline into the drainage hole. Use flexible drainage tube and tighten it with thread loop. Never use adhesive to connect the drainage hole and the flexible drainage tube. (As shown in Figure 1-2-9)

- When the laid drainage pipe is used for multiple units, the common pipe shall be about 100mm lower than the drainage outlet of each set of unit. A pipe with thicker wall shall be used for such purpose.

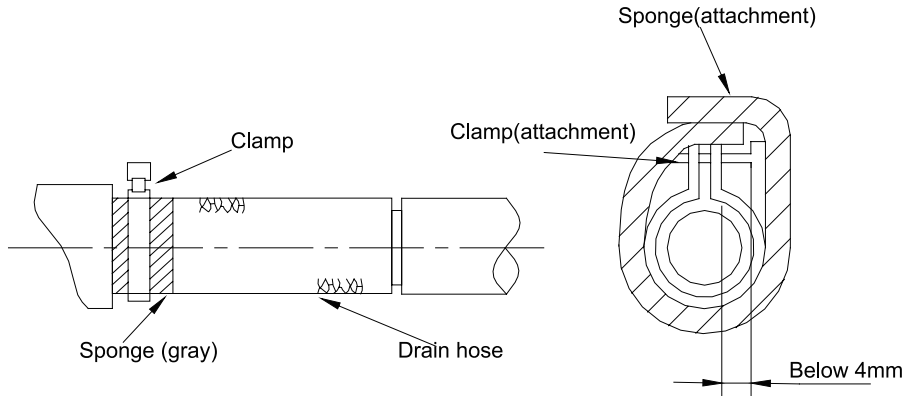

Figure 1-2-9

b. Testing of Drainage System

- After the electrical installation is completed, carry out the testing of the drainage system.

- During the test, check if the water correctly flows through the pipelines. Carefully observe the joints to ensure that there is no leakage. If the unit is to be installed in a new house, carry out testing before decorating the ceiling.

- Matters of Attention

- The drain pipe outlet direction can be chosen from either the right rear or right.

- The diameter of the drain pipe should be equal to or greater than the diameter of the connecting pipe.

(Vinyl tube; pipe size: 20mm; outer dimension: 26mm)

- Keep the drain pipe short and incline downwards at a gradient of at least 1/100 to prevent air pockets.

(Refer to Figure 1-2-10)

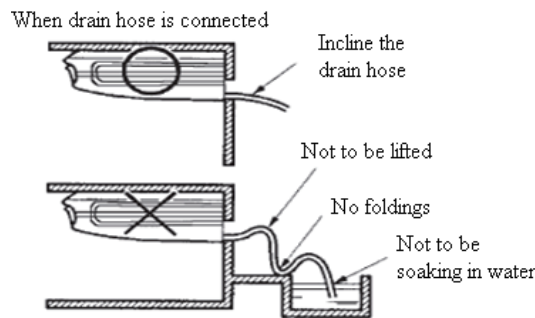

Figure 1-2-10

- No folding of drain hose inside the indoor unit. (Refer to Figure 1-2-11)

- Confirm that smooth drainage is achieved after the piping work. Pour 600 cc of water into the drain pan from the air outlet for confirming drainage. (Refer to Figure 1-2-12)

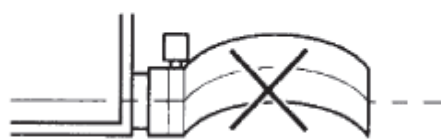

Figure 1-2-11

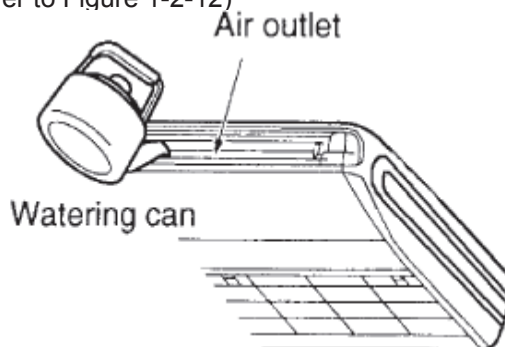

Figure 1-2-12

1.3 Installation of Cassette Type

1.3.1 Before Installation

- After receiving the machine, please check for any transport damage. If finding any surface or internal damage, please immediately report to the transport company or equipment company in writing.

- After receiving the machine, please check the unit and accessories in reference to the packing list. Ensure that the model is correct and the machine is in good condition. Please also check if the specification and quantity of accessory parts are correct.

- Determine the correct handling route and methods, thus to avoid damaging the unit or causing possible hazard. For the sake of protection and safety, it is suggested to move the unit with the packaging box. Even though it is not permitted to do like this under special occasions, do not remove the packaging box, thus to avoid loosening or falling during handling.

- Confirm if the installing foundation is solid. When this unit is to be installed on the metal section of the building, make sure that the electrical insulation must comply with applicable standards.

- Ensure that the place of installation is far from the area where the inflammable or explosive substances are stored, thus to avoid possible explosion or fire due to leakage.

1.3.2 Installation Site

- Obstruct should put away from the intake or outlet vent of the indoor unit so that the airflow can be blown through all the room.

- Make sure that the installation had accord with the requirement of the schematic diagram of installation spaces.

- Select the place where can stand 4 times of the weight of the indoor unit and would not increase the operating noise and oscillate.

- The horizontally of the installation place should be guaranteed.

- Select the place where is easy to drain out the condensate water, and connect with outdoor unit.

- Make sure that there are enough space for care and maintenance. Make sure that the weight between the indoor unit and ground is above 2300mm.

- When installing the steeve bolt, check if the install place can stand the weight 4 times of the unit's. If not, reinforce before installation. (Refer to the install cardboard and find where should be reinforced) The appliance shall not be installed in laundry.

Cautions:

There will be lots of lampblack and dust stick on the acentric, heat exchanger and water pump in dining room and kitchen, which would reduce the capacity of heat exchanger, lead water leakage and abnormal operation of the water pump.

The following treatment should be taken under this circumstance:

Ensure that the smoke trap above cooker has enough capacity to obviate lampblack to prevent the indraft of the lampblack by the air conditioner.

Keep the air conditioner far from the kitchen so that the lampblack would not be indraft by the air conditioner.

1.3.3 Caution for Installation

a. Important notice:

- To guarantee the good performance, the unit must be installed by professional personnel according with this instruction.

- Please contact the local Gree special nominated repair department before installation. Any malfunction caused by the unit that is installed by the department that is not special nominated by Gree would not deal with on time by the inconvenience of the business contact.

b. Dimension of ceiling opening and location of the hoisting screw (M10)

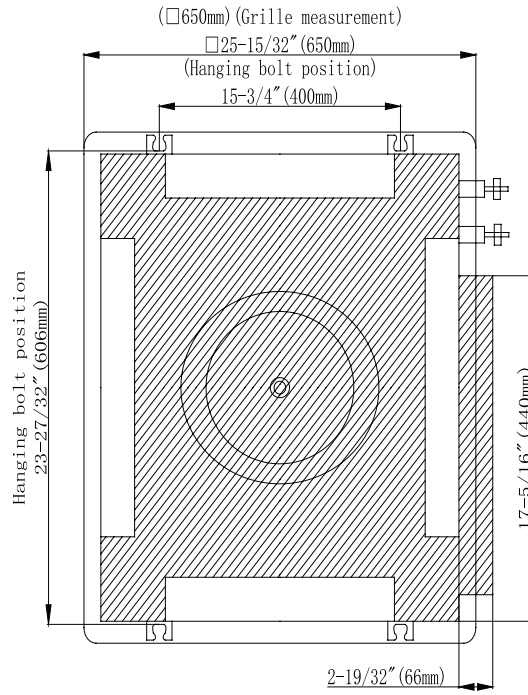

GKH12K3CI

Figure 1-3-1

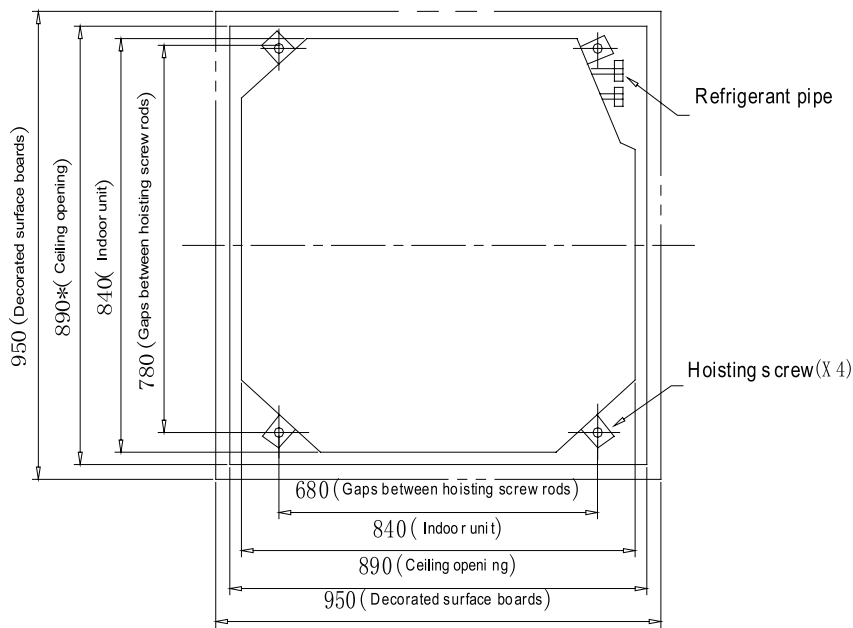

GKH18K3CI / GKH24K3CI / GKH30K3CI / GKH36K3CI / GKH42K3CI

Figure 1-3-2

The drilling of holes in the ceiling must be done by the professional personnel.

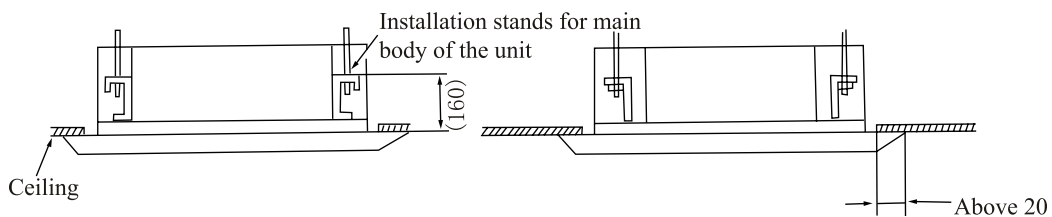

Figure 1-3-3

Cautions:

The dimension for the ceiling openings with * marks can be as large as 910mm. But the overlapping sections of the ceiling and the decorated surface boards should be maintained at no less than 20mm.

c. Main body of hoisting air conditioner

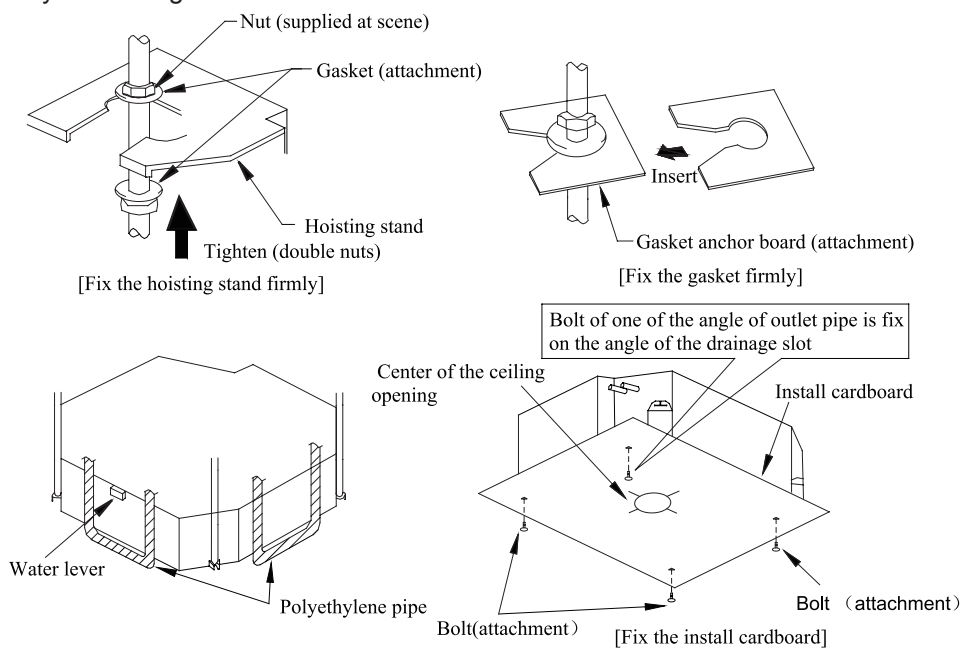

Figure 1-3-4

- The primary step for install the indoor unit.

When attach the hoisting stand on hoisting screw, do use nut and gasket individually at the upper and lower of the hoisting stand to fix it. The use of gasket anchor board can prevent gasket break off.

- Use install cardboard

Please refer to the install cardboard about the dimension of ceiling opening.

The central mark of the ceiling opening is marked on the install cardboard.

Install the install cardboard on the unit by bolt (3 piece), and fix the angle of the drainage pipe at the outlet vent by bolt.

- Adjust the unit to the suitable install place.
- Check if the unit is horizontal.

Inner drainage pump and bobber switch are included in the indoor unit, check if 4 angle of every unit are horizontal by water lever. (If the unit is slant toward the opposite of the coagulate water flow, there may be malfunction of the bobber switch and lead water drop.)

- Backout the gasket anchor board used to prevent gasket break off and tighten the nut on it.
- Backout the install cardboard.

Cautions:

Please do tighten the nuts and bolts to prevent air conditioner break off.

1.3.4 Dimension Data

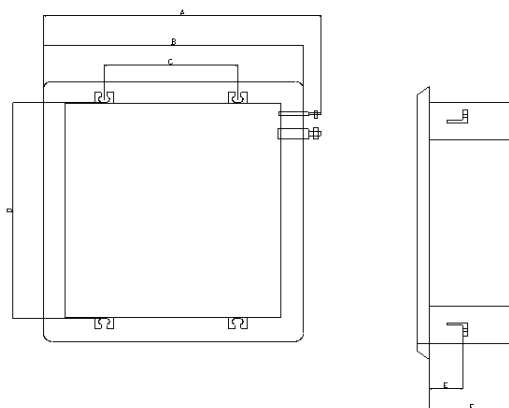

Figure 1-3-5

Model	A	B	C	D	E	F
GKH12K3CI	710	650	400	606	160	250

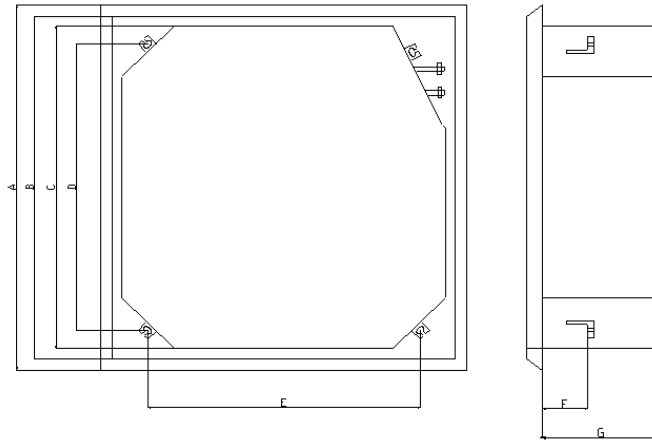

Figure 1-3-6

Model	A	B	C	D	E	F	G
GKH18K3CI	950	890	840	780	680	160	240
GKH24K3CI	950	890	840	780	680	160	240
GKH30K3CI	950	890	840	780	680	160	320
GKH36K3CI							
GKH42K3CI							

1.3.5 Installation Clearance Data

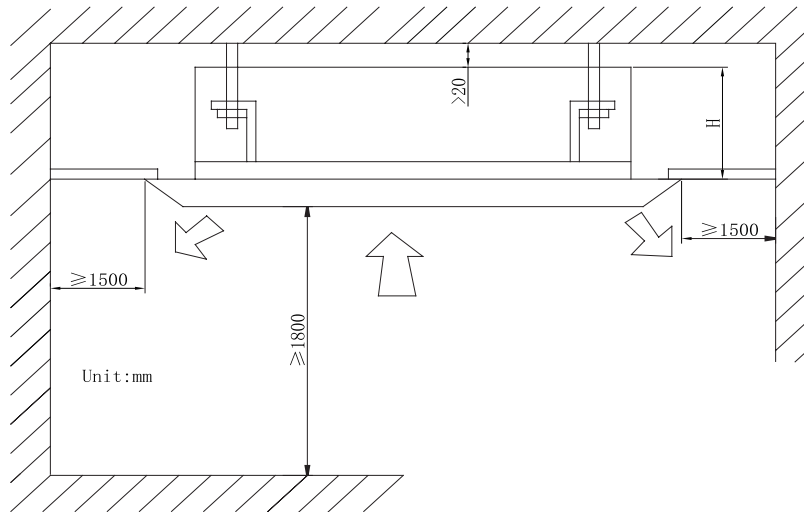

Figure 1-3-7

Models	H(mm)
GKH12K3CI	250
GKH18K3CI GKH24K3CI	260
GKH30K3CI GKH36K3CI GKH42K3CI	340

1.3.6 Drain Piping Work

a. Installation of Drainage Pipeline

- When connecting the drainage pipe with the unit, do not apply excessive force to the pipeline at the side of the unit. The fixing position of the pipeline shall be near the unit.
- Purchase general-purpose hard PVC pipe locally to be used as the drainage pipeline. When carrying out connection, place the end of the PVC pipeline into the drainage hole. Use flexible drainage tube and tighten it with thread loop. Never use adhesive to connect the drainage hole and the flexible drainage tube. (As shown in Figure 1-3-7)
- When the laid drainage pipe is used for multiple units, the common pipe shall be about 100mm lower

than the drainage outlet of each set of unit. A pipe with thicker wall shall be used for such purpose.

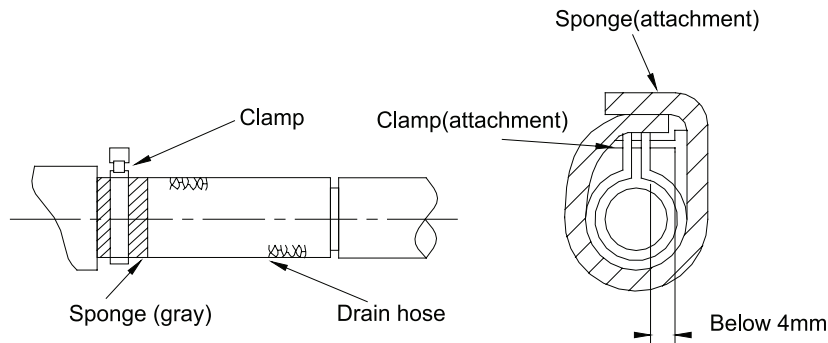

Figure 1-3-8

b. Testing of Drainage System

- After the electrical installation is completed, carry out the testing of the drainage system.
- During the test, check if the water correctly flows through the pipelines. Carefully observe the joints to ensure that there is no leakage. If the unit is to be installed in a new house, carry out testing before decorating the ceiling.

c. Matters of Attention

- The diameter of the drain hose should be equal or bigger than the connection pipe's. (The diameter of polythene pipe: Outer diameter 25mm Surface thickness $\geq 1.5\text{mm}$)
- Drain hose should be short and drooping gradient should at less 1/100 to prevent the formation of air bubble.
- If drain hose cannot has enough drooping gradient, drain raising pipe should be added.
- To prevent bent of the drain hose, the distance between hoisting stand should is 1 to 1.5m. (As shown in Figure 1-3-8)

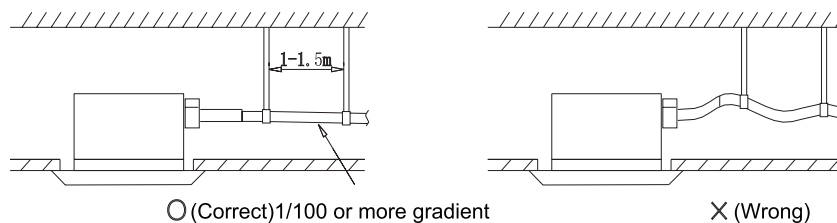

Figure 1-3-9

- The install height of the drain raising pipe should less than 280mm.
- The drain raising pipe should form a right angle with the unit, and distance to unit should not beyond 300mm. (As shown in Figure 1-3-9)

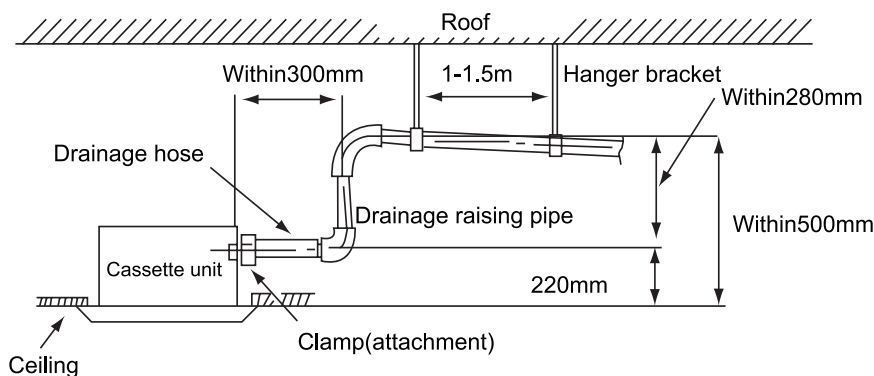

Figure 1-3-10

- The slant gradient of the attached drain hose should be within 75mm so that the drain hole doesn't has to endure the unnecessary outside force. (As shown in Figure 1-3-10)

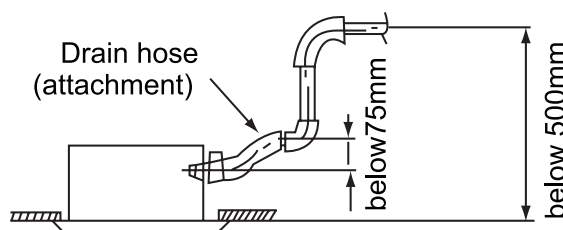
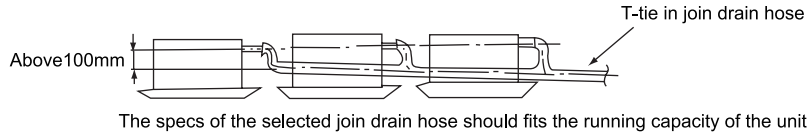

Figure 1-3-11

- Please install the drain hose according to the following process if several drain hoses join together. (As shown in Figure 1-3-11)



- Check the smoothness of drain after installation.
- Check the drain state by immiting 600cc water slowly from the outlet vent or test hole. (As shown in Figure 1-3-12)
- Check the drain in the state of refrigerating after installation of the electric circuit.

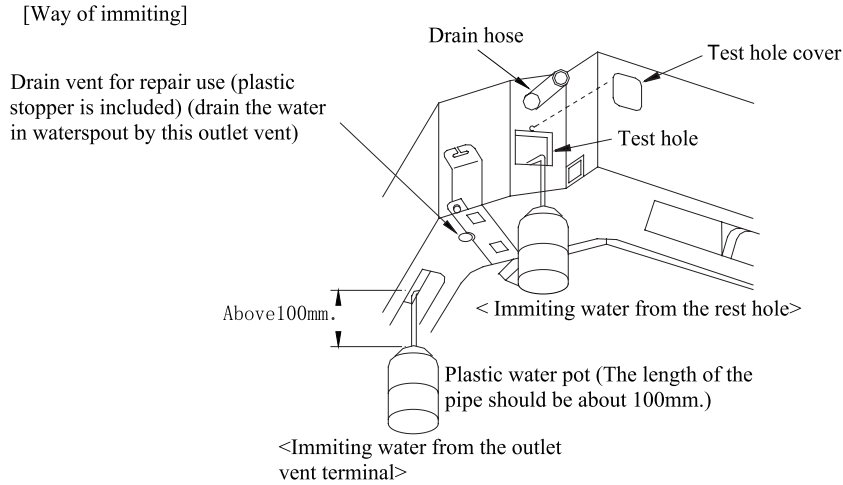

Figure 1-3-12

1.3.7 Installation of panel

- Set the panel to the indoor unit body by matching the position of the swing flap motor of the decoration panel to the piping position of the panel to the piping position of the indoor unit as shown in Figure 1-3-13.

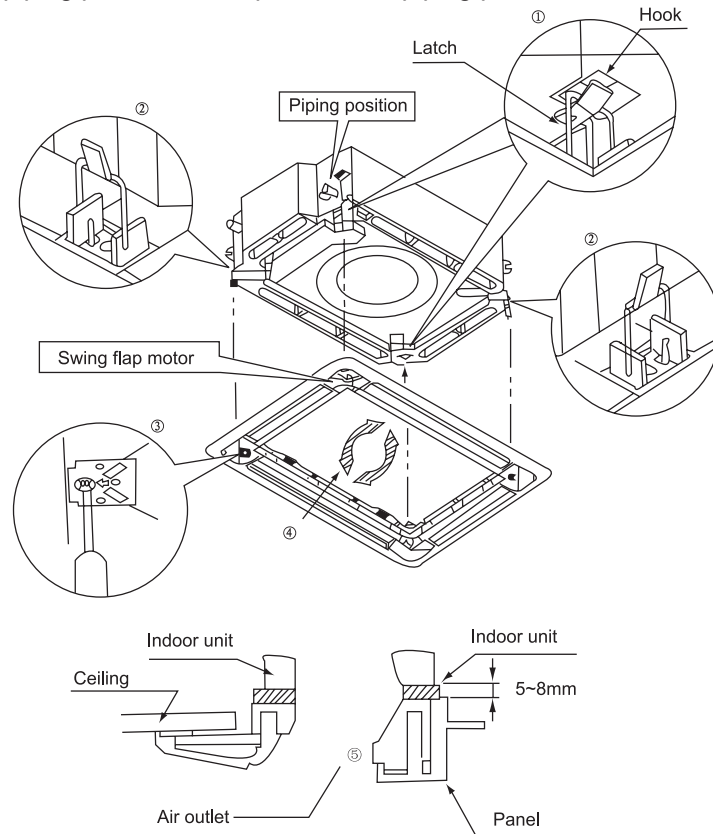

Figure 1-3-13

- Hang the latch, which is located on the opposite side of the swing flap motor on the panel, temporarily to the book of the indoor unit. (2 Positions)
- Temporarily hang the remaining 2 latches to the hooks on the sides of the indoor unit.(Be careful not

to let the swing motor lead wire get caught in the sealing material.)

- Screw all 4 hexagon head screws located right beneath the latches in approximately 15mm.(Panel will rise)
- Adjust the panel by turning it to the arrowed direction in Fig.4 so that the ceiling opening is completely covered.
- Tighten the screws until the thickness of the sealing material between the panel and the indoor unit body is reduced to 5~8 mm.

b. Precautions:

- Improper screwing of the screws may cause the troubles shown in Figure 1-3-14.

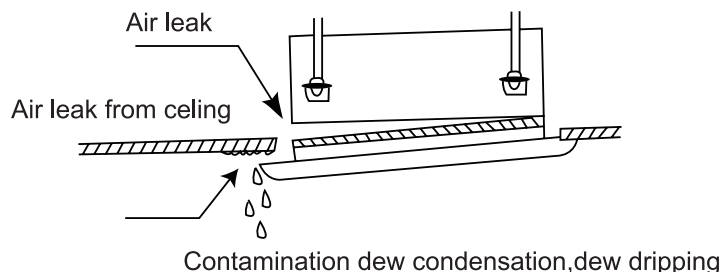

Figure 1-3-14

- If gap is still left between the ceiling and the panel after screwing the screws, readjust the height of the indoor unit body (Refer to Figure 1-3-15).

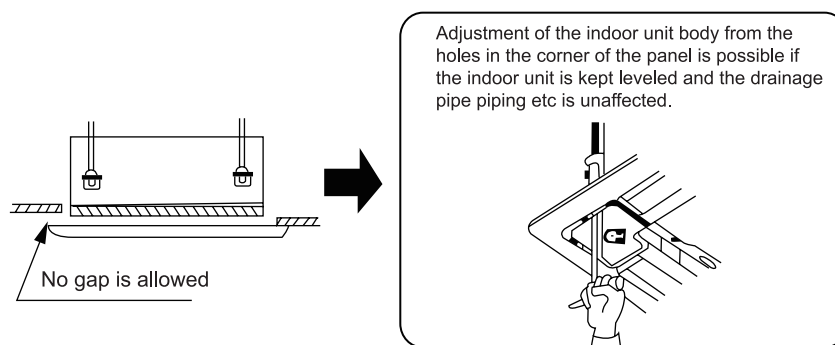

Figure 1-3-15

- After fixing be sure no gap left between the ceiling and the panel.

c. Wiring of the decoration panel.

- Connect the joints for swing flap motor lead wire (at 2 places) installed on the panel (Refer to Figure 1-3-16).

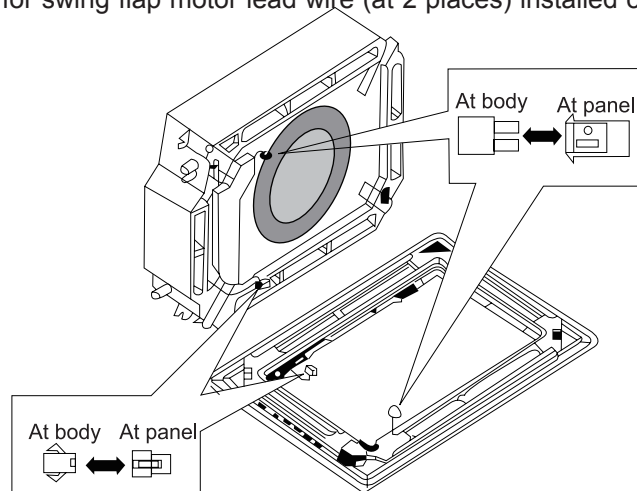

Figure 1-3-16

2 OUTDOOR UNIT INSTALLATION

2.1 Before Installation

- After receiving the machine, please check for any transport damage. If finding any surface or internal damage, please immediately report to the transport company or equipment company in writing.
- After receiving the machine, please check the unit and accessories in reference to the packing list. Ensure that the model is correct and the machine is in good condition. Please also check if the specification

and quantity of accessory parts are correct.

- Determine the correct handling route and methods, thus to avoid damaging the unit or causing possible hazard. For the sake of protection and safety, it is suggested to move the unit with the packaging box. Even though it is not permitted to do like this under special occasions, do not remove the packaging box, thus to avoid loosening or falling during handling.
- Confirm if the installing foundation is solid. When this unit is to be installed on the metal section of the building, make sure that the electrical insulation must comply with applicable standards.
- Ensure that the place of installation is far from the area where the inflammable or explosive substances are stored, thus to avoid possible explosion or fire due to leakage.

2.2 Installation Site

- To ensure the unit in proper function, selection of installation location must be in accordance with following principles:
 - Outdoor unit shall be installed so that the air discharged by outdoor unit will not return and that sufficient space for repair shall be provided around the machine.
 - The installation site must have good ventilation, so that the outdoor unit can take in and exhaust enough air. Ensure that there is no obstacle for the return air inlet and exhaust of the outdoor unit. If there is any obstacle blocking the return air inlet or exhaust, remove it.
 - Place of installation shall be strong enough to support the weight of outdoor unit, and it shall be able to insulate noise and prevent vibration. Ensure that the wind and noise from the unit will not affect your neighbors.
 - Avoid direct sunshine over the unit. It is better to set up a sun shield as the protection.
 - Place of installation must be able to drain the rainwater and defrosting water.
 - Place of installation must ensure the machine will not be buried under snow or subject to the influence of rubbish or oil fog.
 - The installation site must be at a place where the air exhaust outlet does not face strong wind.
 - The outdoor unit must be lifted by using the designated lift hole. During lifting, take care to protect the air conditioner and avoid knocking the metal parts, thus to prevent rusting in the future.
 - To meet the noise and vibration requirements, the outdoor unit shall be installed by using rubber damping pad or spring damper.
 - The installing dimension shall comply with the installation requirements in these instructions. The outdoor unit must be fixed at the installing position.
 - The installation shall be done by specialist technicians.

2.3 Caution for Installation

- The outdoor unit shall be so installed that the air discharged out of the outdoor unit will not flow back and that enough space shall be maintained around the machine for repair;
- The installing position shall be in good ventilation, so that the machine can breathe and exhaust enough air. Ensure that there is no obstruction at the inlet and outlet of the machine. If any, please remove the obstructions blocking the air inlet and outlet.
 - If the outdoor unit is installed on concrete or solid ground, it shall be fixed by using M10 bolts and nuts. And ensure that the machine is kept vertical and horizontal.
 - The outdoor unit must be lifted by using the designated lift hole. During lifting, take care to protect the air conditioner and avoid knocking the metal parts, thus to prevent rusting in the future.
 - To meet the noise and vibration requirements, the outdoor unit shall be installed by using rubber damping pad or spring damper.
 - To install the drainage pipe, please insert the drainage joint to the drainage hole on the outdoor chassis and connect a drainage pipe on the drainage joint. (The installing height of outdoor unit shall be at least 5cm if drainage joint is to be used).
 - To insert the pipe through the wall, the wall-cross tube must be installed.
 - The installing dimension shall comply with the installation requirements in these instructions. The outdoor unit must be fixed at the installing position.
 - The installation shall be done by specialist technicians.

2.4 Dimension Data

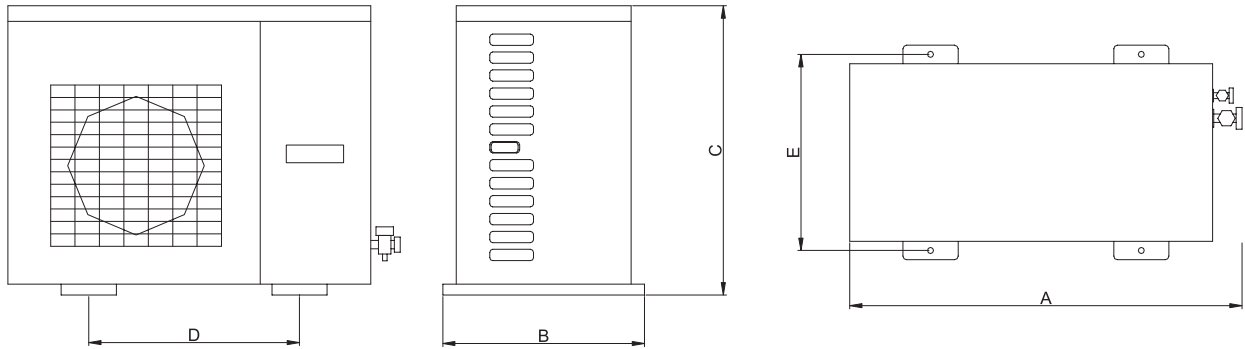

Figure 1-3-17

Unit:mm

Item	A	B	C	D	E
model					
GUHD09NK3CO/GUHD12NK3CO	776	320	540	510	286
GUHD09NK3C1O/GUHD12NK3C1O	848	320	540	540	286
GUHD18NK3CO/GUHD18NK3C1O	955	396	700	560	360
GUHD24NK3CO/GUHD24NK3C1O GUHD30NK3CO/GUHD30NK3C1O	980	427	790	610	395
GUHD36NK3CO/GUHD36NK3C1O GUHD36NM3CO/GUHD36NM3C1O GUHD42NK3CO/GUHD42NK3C1O GUHD42NM3CO/GUHD42NM3C1O	1107	440	1100	631	400
GUHD48NK3CO/GUHD48NK3C1O GUHD48NM3CO/GUHD48NM3C1O GUHD60NM3CO/GUHD60NM3C1O	1085	427	1365	620	395

2.5 Installation Clearance Data

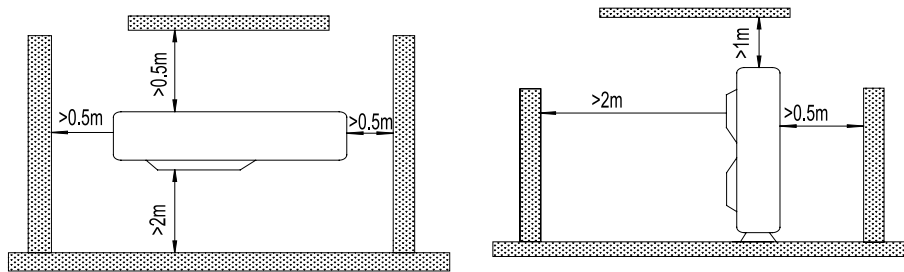

Figure 1-3-18

3 REFRIGERATION PIPING WORK

3.1 Refrigeration Piping Work Procedures

a. Connection Pipe

- The connection pipe must meet the following requirements. The three basic principles are that the pipe shall be kept dry, clean and no leakage.

The principles of refrigerant piping

Dry	Clean	Air tight
Make sure there is no moisture inside the pipe.	Make sure there is no dirt inside the pipe.	Make sure the refrigerant does not leak out.

Figure 3-1-1

- Align the flared end of copper pipe with the center of threaded connector and use your hands to securely tighten the flared nuts.
- Tighten the flared nuts with torque wrench, until you hear a ‘KATA’ sound from the torque wrench, as shown in Fig. 3-1-1. See Table 3-1-1 for the torque required for tightening the nuts.

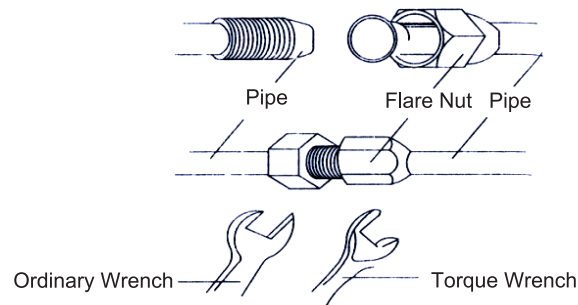

Figure 3-1-2

Form 3-1-1 the tightening torque needed for tightening nut

Pipe diameter	Tightening Torque
1/4 (Inch)	15-30 (N·m)
3/8(Inch)	35-40 (N·m)
5/8(Inch)	60-65 (N·m)
1/2 (Inch)	45-50 (N·m)
3/4 (Inch)	70-75 (N·m)
7/8 (Inch)	80-85 (N·m)

- The bend of pipe shall not be too small; otherwise the pipe might be broken. Please use pipe bender to bend the pipe.
- Generally, the pipe shall be welded with the weld junction upward or horizontal. Avoid welding with the pipe opening downward. (Downward welding is easy to cause defects, which may affect the weld quality or even cause leakage, as show in Fig. 3-1-3).

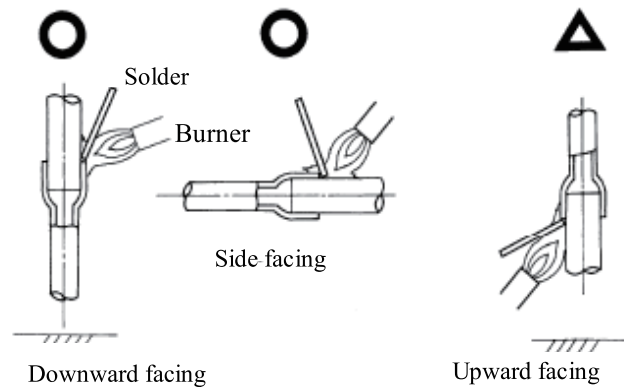

Figure 3-1-3

- Use sponge to wrap the connection pipes and connectors that are not thermally insulated, and tighten with plastic tapes.
- b. Vacuum and Leakage Detection
 - Remove the cap from liquid valve and gas valve.
 - Align with the pipe center and tighten the jointing nuts adequately with your hand.
 - Tighten the nuts with wrench.
 - Remove the 1-way cap from the gas valve.
 - Use the hexagonal socket spanner to rotate the element of liquid valve for 1/4 turns and use the screwdriver to prop up the element of gas valve to discharge the gas.
 - Discharge the gas for 15 seconds, until refrigerant gas appears. The, immediately close the 1-way valve and tighten the valve cap.
 - Open the element of liquid valve and gas valve to full (See Fig. 3-1-4).

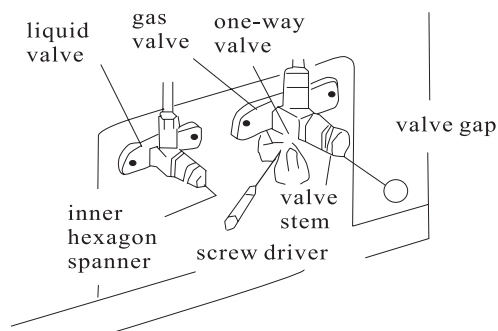

Figure 3-1-4

- Tighten the valve cap and then use soap water or leakage detector to check the connection between outdoor unit and pipe for any leakage.

Caution:

If possible, it is best to discharge the air out of the machine from the valve by using vacuum pump. To establish vacuum by using vacuum pump, please operate as follows:

- Take out the nut cover of the inlet for refrigerant.
- Connect the tube of the vacuum watch with the vacuum pump, having the low-pressure end linking to the inlet for refrigerant. (As shown in Figure 3-1-5)

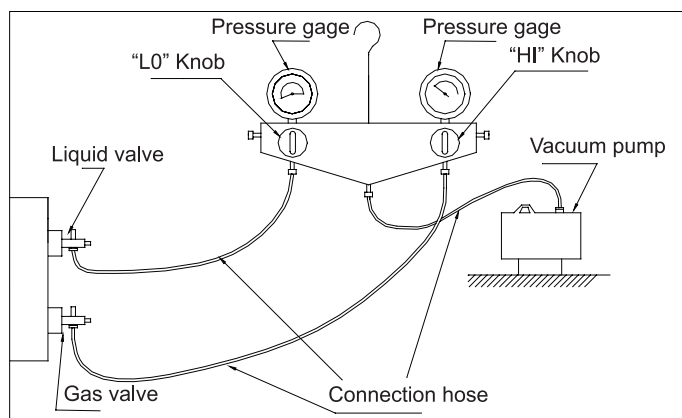

Figure 3-1-5

- Starting the vacuum pump, when the indicator turns to -1 bar, closing the low pressure handle and stopping vacuumize. Keep for 15 minutes, ensuring the pressure of the vacuum watch remains.
- Take out the valve cover of the gas valve together with the liquid valve.
- Loosing the cord of liquid valve until the pressure rise to 0 bar.
- Dismantle the tube from the cover of the inlet for refrigerant then, tighten the cover.
- Loose the valve cord of the gas valve as well as the liquid valve entirely.
- Tighten the valve cover of the gas valve and liquid valve so as to check whether leakage occurred.

c. Installation of Protective Layer of Connecting Pipe

• To avoid generation of condensate on the connecting pipe and avoid leakage, the big pipe and the small pipe of the connecting pipe must be covered by thermal insulation materials, be bundled by adhesive tape, and be isolated from air.

• The joint connecting to the indoor unit must be wrapped by thermal insulation material. There shall be no gap between the connecting pipe joint and the wall of the indoor unit. Refer to Figure 3-1-6.

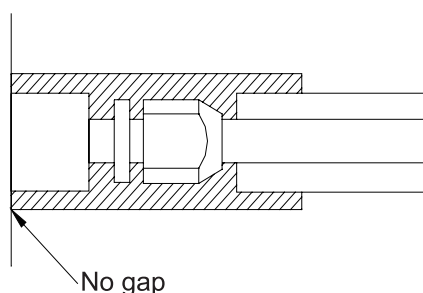

Figure 3-1-6

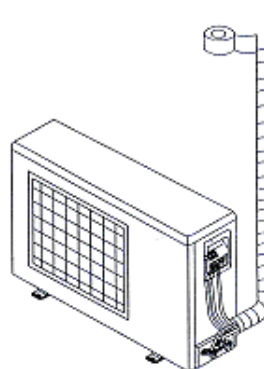

Figure 3-1-7

- Use adhesive tape to bundle the connecting pipe and the cables together. To prevent condensate from overflowing out from the drainage pipe, separate the drainage pipe from the connecting pipe and the cables.
- Use thermal insulation tape to wrap the pipes from the bottom of the outdoor unit until the upper end of the pipe where the pipe enters the wall. When wrapping thermal insulation tape, the later circle of tape must cover half of the front circle of tape (Figure 3-1-7).
- Wrapped pipe must be fixed to wall using pipe clamps.

Caution:

After the pipes are wrapped by protective materials, never bend the pipes to form very small angle, and otherwise the pipes may crack or break.

Do not wrap the protective tape too tight, otherwise the efficiency of thermal insulation may be decreased. Ensure that the condensate drainage flexible tube is separate from the bundled pipes.

After the protective work is completed and the pipes are wrapped, use seal material to block the hole in the wall, so as to prevent rain and wind from entering the room.

3.2 Caution in Connecting Pipes

The layout of connection pipes shall be in reference to the following principles according to site conditions:

- Shorten the connection pipe to minimum, preferably within 5m.
- Reduce the height difference between indoor and outdoor units as it might be.
- Minimize the number of elbows on connection pipe.

If the connection pipe is longer than 20m, it is needed to check if the lubricating oil in the system is enough. Add if needed.

The refrigerant charge volume inside the machine is suitable for 7m connection pipe. To extend the length of connection pipe, it is needed to add an appropriate quantity of refrigerant. For extension of pipe length by every 1 meter, the refrigerant to be added is as follows. The maximum allowable length of pipe is as follows.

If the height difference between indoor and outdoor units is over 10m, it is required to install an oil trap every 6 meters.

When the indoor and outdoor units are on different height, please refer to Fig. 30201 for pipe layout.

- _____ Liquid pipe (i.e. fine pipe)
- Gas pipe (i.e. coarse pipe)

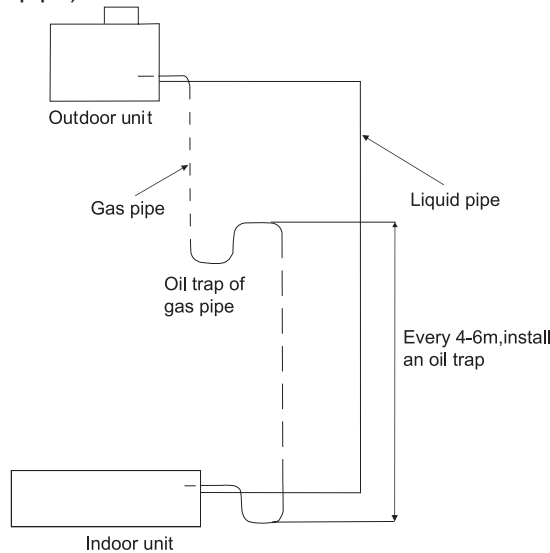

Figure 3-2-1

3.3 Specification of Connection Pipe

Model \ Item	Size of Fitting Pipe(Inch)		Max. Pipe Length (m)	Max. Height Difference between Indoor Unit and Outdoor Unit m	Amount of Additional Refrigerant to be Filled (For Extra Length of Pipe)
	Liquid	Gas			
GUHD09NK3CO/GUHD09NK3C1O GUHD12NK3CO/GUHD12NK3C1O	1/4	3/8	20	15	30g/m
GUHD18NK3CO/GUHD18NK3C1O	1/4	1/2			
GUHD24NK3CO/GUHD24NK3C1O GUHD30NK3CO/GUHD30NK3C1O GUHD36NK3CO/GUHD36NK3C1O GUHD36NM3CO/GUHD36NM3C1O	3/8	5/8	30	15	60g/m
GUHD42NK3CO//GUHD42NK3C1O GUHD42NM3CO/GUHD42NM3C1O GUHD48NK3CO/GUHD48NK3C1O GUHD48NM3CO/GUHD48NM3C1O	3/8	5/8	50	30	60g/m
GUHD60NM3CO/GUHD60NM3C1O	3/8	3/4	50	30	60 g/m

4 ELECTRIC WIRING WORK

4.1 Wiring Principle

4.1.1 General

- a. Perform wiring of the power supply in conformance with the regulations of the local electric company.
- b. For the control wires connecting indoor units, and between indoor and outdoor units, use of double-core shield wires is recommended to prevent noise trouble.
- c. Be sure to set the earth leakage breaker and the switches to the power supply section of the indoor unit.
- d. Supply power to each outdoor unit and provide an earth leakage breaker or hand switch for each outdoor unit.
- e. Store wiring system for control and refrigerant piping system in the same line.
- f. Arrange the cables so that the electric wires do not come to contact with high-temperature part of the refrigerant pipe; otherwise coating melts and an accident may be caused.
- g. Do not turn on power of the indoor unit until vacuuming of the refrigerant pipe will finish.
- h. Installation should be conducted by National Wiring Regulation.
- i. The rated voltage and exclusive power supply must be adopted for the air conditioners.
- j. The power cable should be reliable and fixed, in order to avoid the wiring terminal be suffered from force. And do not drag the power cable forcibly.
- k. The wire diameter of power cable should be large enough, if power cable and connection wire be damaged, it should be replaced by the exclusive cable.
- l. All electric installation must be done by professional personnel according to local law, regulation and this manual.
- m. It should be reliably earthed, and it should be connected to the special earth device, the installation work should be operated by the professional.
- n. The creepage protect switch and air switch must be installed.
- o. Air switch should have the thermal dropout and magnetic dropout function, in order to avoid the short circuit and overload.
- p. The on spot connection should refer to the circuit diagram, which is stuck on the unit body.
- q. The unit should be reliably earth, if it is improperly earthed that may cause electric shock or fire.
- r. Air conditioner is the "I" class electric appliance, thus please do conduct reliable grounding measure.
- s. The yellow-green two-color wiring of air conditioner is grounding wire and cannot be used for other purposes. It cannot be cut off and be fixed by screw, otherwise it would cause electric shock.
- t. The user must offer the reliable grounding terminal. Please don't connect the grounding wire to the following places:
 - Water pipe
 - Gas pipe
 - Blowing pipe
 - Other places that professional personnel consider them unreliable.

4.1.2 Connection between power cables and wiring terminals

Caution

Before installing the electrical equipment, please pay attention to the following matters which have been specially pointed out by our designers:

Check to see if the power supply used conforms to the rated power supply specified on the nameplate. The capacity of the power supply must be large enough. The section area of fitting line in the room shall be larger than 2.5mm².

The lines must be installed by professional personnel.

An electricity leakage protection switch and an air switch with gap between electrode heads larger than 3 mm shall be installed in the fixed line.

a. Connection of single wire

- Use wire stripper to strip the insulation layer (25mm long) from the end of the single wire.
- Remove the screw at the terminal board of the air-conditioning unit.
- Use pliers to bend the end of the single wire so that a loop matching the screw size is formed.
- Put the screw through the loop of the single wire and fix the loop at the terminal board.

b. Connection of multiple twisted wires

- Use wire stripper to strip the insulation layer (10mm long) from the end of the multiple twisted wires.
- Remove the screw at the terminal board of the air-conditioning unit.
- Use crimping pliers to connect a terminal (matching the size of the screw) at the end of the multiple twisted wires.

- Put the screw through the terminal of the multiple twisted wires and fix the terminal at the terminal board.

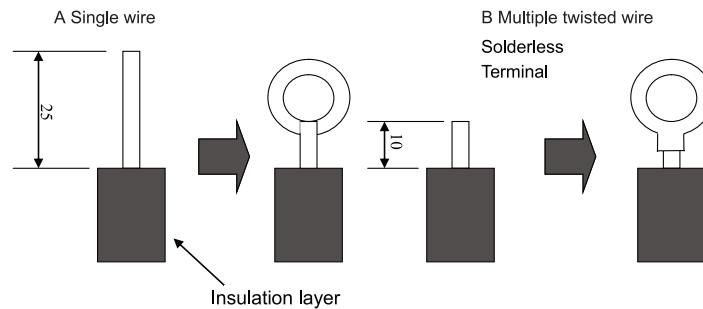

Warning:

If the power supply flexible line or the signal line of the equipment is damaged, only use special flexible line to replace it.

Before connecting lines, read the voltages of the relevant parts on the nameplate. Then carry out line connection according to the schematic diagram.

The air-conditioning unit shall have special power supply line which shall be equipped with electricity leakage switch and air switch, so as to deal with overload conditions.

The air-conditioning unit must have grounding to avoid hazard owing to insulation failure.

All fitting lines must use crimp terminals or single wire. If multiple twisted wires are connected to terminal board, arc may arise.

All line connections must conform to the schematic diagram of lines. Wrong connection may cause abnormal operation or damage of the air-conditioning unit.

Do not let any cable contact the refrigerant pipe, the compressor and moving parts such as fan.

Do not change the internal line connections inside the air-conditioning unit. The manufacturer shall not be liable for any loss or abnormal operation arising from wrong line connections.

4.1.3 Power Cable Connection

a. Air-conditioning unit with single-phase power supply

- Remove the front-side panel of the outdoor unit.
- Pass the cable through rubber ring.
- Connect the power supply cable to the "L, N" terminals and the grounding screw.
- Use cable fastener to bundle and fix the cable.

b. Air-conditioning unit with 3-phase power supply

- Remove the front-side panel of the outdoor unit.
- Attach rubber ring to the cable-cross hole of the outdoor unit.
- Pass the cable through rubber ring.
- Connect the power cable to the terminal and earthing screws marked "L1, L2, L3 & N".
- Use cable fastener to bundle and fix the cable.
- Caution:

- For air-conditioner with auxiliary heater, it is required to connect the power cable to the “L1, L2 L3” terminals and the grounding screw.

4.1.4 Connection of Signal Line of Wire Controller

Caution:

Take great care when carrying out the following connections, so as to avoid malfunction of the air-conditioning unit because of electromagnetic interference.

The signal line of the wire controller must be separated from the power line and the connecting line between the indoor unit and the outdoor unit.

In case the unit is installed in a place vulnerable by electromagnetic interference, it is better to use shielded cable or double-twisted cable as the signal line of the wire controller.

Open the cover of the electric box of the indoor unit.

Pull the signal cable of the wire controller through the rubber ring.

Plug the signal line of the wire controller onto the 4-bit pin socket at the circuit board of the indoor unit.

Use cable fastener to bundle and fix the signal cable of the wire controller.

4.1.5 Cable Connection

Remove the right side plate of the indoor unit and punch through the cable-cross hole. Mount the cable-cross loop.

Remove the cable clamp. Connect the power cable to the terminal and fix it.

Fix the power cable and signal control wire with cable clamp. Then, connect to corresponding connector properly.

Confirm if the cables are securely fixed.

Mount the front side plate.

4.2 Electric Wiring Design

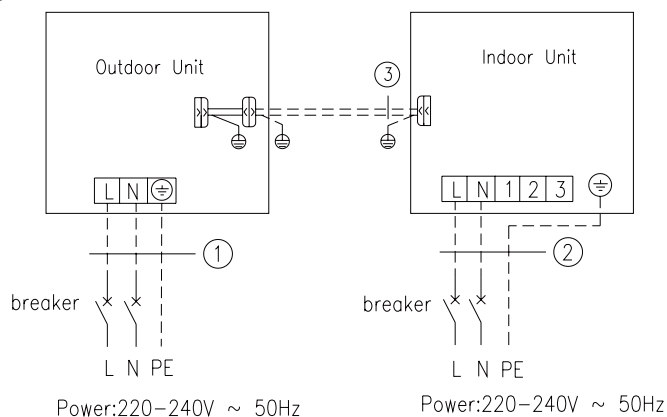

GUHD09NK3CO / GUHD09NK3C1O + GFH09K3CI GUHD12NK3CO / GUHD12NK3C1O + GFH12K3CI 1. Power cord 3×2.5 mm ² (H07RN-F) 2. Power cord 3×1.0 mm ² (H05VV-F) 3. Communication Cords	
GUHD36NK3CO/ GUHD36NK3C1O + GFH36K3CI GUHD42NK3CO/ GUHD42NK3C1O + GFH42K3CI 1.Power cord 3×4.0 mm ² (H07RN-F) 2.Power cord 3×1.0 mm ² (H05VV-F) 3.Communication Cords	
GUHD48NK3CO/ GUHD48NK3C1O + GFH48K3CI 1.Power cord 3×6.0 mm ² (H07RN-F) 2.Power cord 3×1.0mm ² (H05VV-F) 3.Communication Cords	

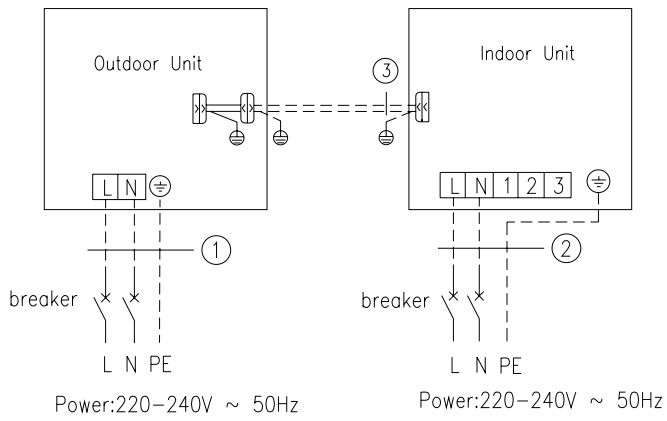

GUHD18NK3CO / GUHD18NK3C1O + GFH18K3CI
 GUHD24NK3CO / GUHD24NK3C1O + GFH24K3CI
 GUHD30NK3CO / GUHD30NK3C1O + GFH30K3CI
 1. Power cord 3×4.0mm²(H07RN-F) 2. Power cord 3×1.0 mm²(H05VV-F)
 3. Communication Cords

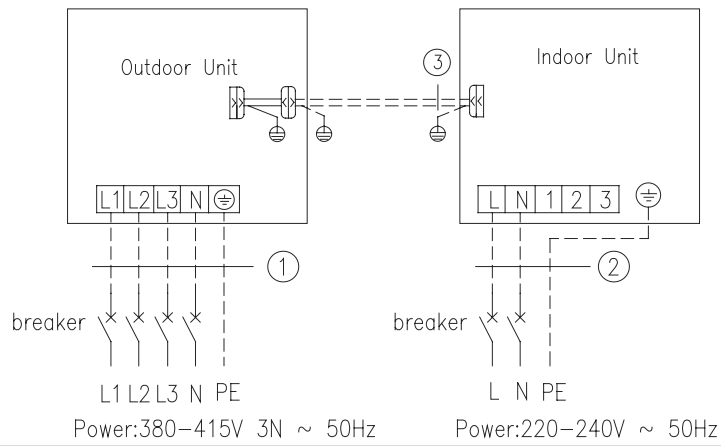

GUHD36NM3CO/ GUHD36NM3C1O + GFH36K3CI
 GUHD42NM3CO / GUHD42NM3C1O + GFH42K3CI
 GUHD48NM3CO / GUHD48NM3C1O + GFH48K3CI
 GUHD60NM3CO / GUHD60NM3C1O + GFH60K3CI
 1.Power cord 5×2.5 mm²(H07RN-F) 2.Power cord 3×1.0 mm²(H05VV-F)
 3.Communication Cords

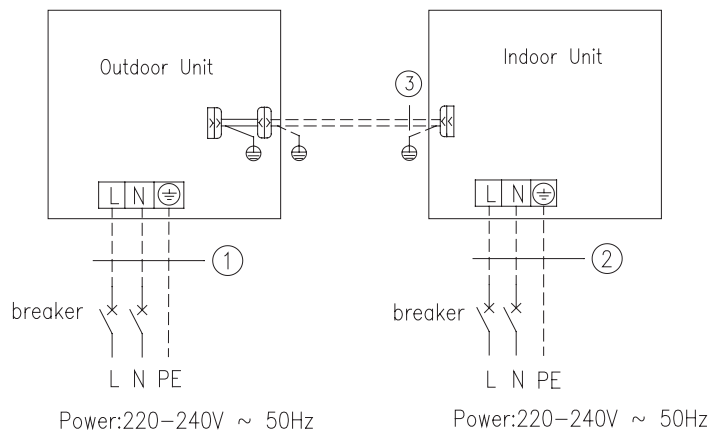

GUHD09NK3CO/ GUHD09NK3C1O + GTH09K3CI
 GUHD12NK3CO/ GUHD12NK3C1O + GTH12K3CI
 1.Power cord 3×2.5 mm²(H07RN-F) 2.Power cord 3×1.0 mm²(H05VV-F)
 3.Communication Cords

<p>GUHD36NK3CO/ GUHD36NK3C1O + GTH36K3CI GUHD42NK3CO/ GUHD42NK3C1O + GTH42K3CI 1.Power cord 3×4.0 mm²(H07RN-F) 2.Power cord 3×1.0 mm²(H05VV-F) 3.Communication Cords</p>
<p>GUHD48NK3CO/ GUHD48NK3C1O + GTH48K3CI 1.Power cord 3×6.0 mm²(H07RN-F) 2.Power cord 3×1.0 mm²(H05VV-F) 3.Communication Cords</p>

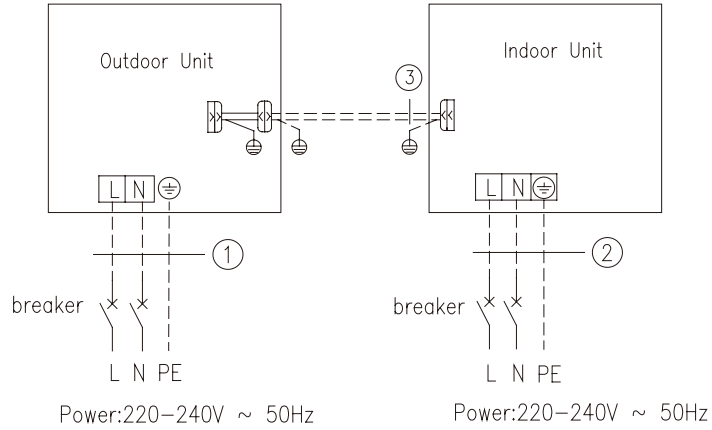

<p>GUHD18NK3CO/ GUHD18NK3C1O + GTH18K3CI GUHD24NK3CO/ GUHD24NK3C1O + GTH24K3CI GUHD30NK3CO/ GUHD30NK3C1O + GTH30K3CI 1.Power cord 3×4.0 mm²(H07RN-F) 2.Power cord 3×1.0 mm²(H05VV-F) 3.Communication Cords</p>

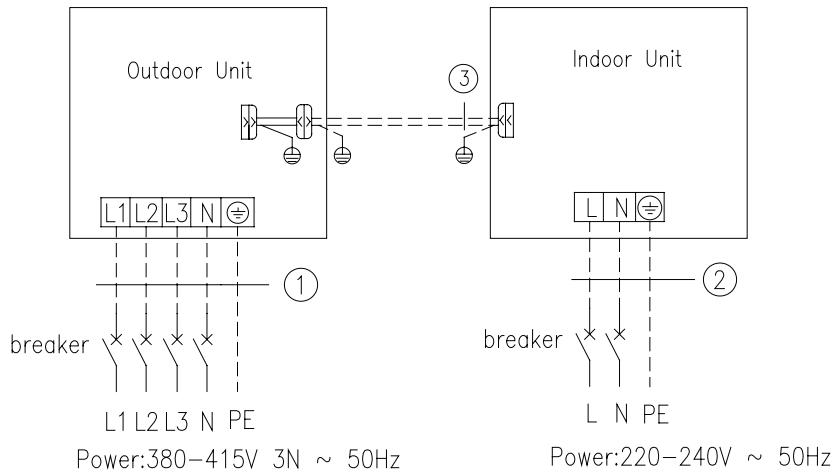

<p>GUHD36NM3CO/ GUHD36NM3C1O + GTH36K3CI GUHD42NM3CO/ GUHD42NM3C1O + GTH42K3CI GUHD48NM3CO/ GUHD48NM3C1O + GTH48K3CI GUHD60NM3CO/ GUHD60NM3C1O + GTH60K3CI 1.Power cord 5×2.5 mm²(H07RN-F) 2.Power cord 3×1.0 mm²(H05VV-F) 3.Communication Cords</p>
--

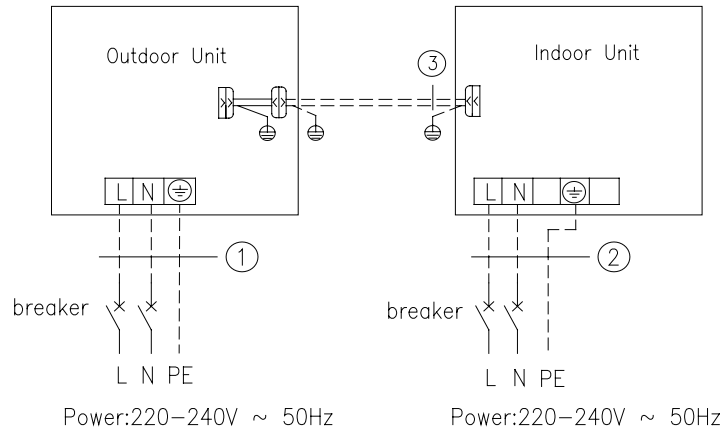

GUHD12NK3CO/ GUHD12NK3C1O + GKH12K3CI 1.Power cord 3×2.5 mm ² (H07RN-F) 2.Power cord 3×1.0 mm ² (H05VV-F) 3.Communication Cords	
GUHD36NK3CO/ GUHD36NK3C1O + GKH36K3CI GUHD42NK3CO/ GUHD42NK3C1O + GKH42K3CI 1.Power cord 3×4.0 mm (H07RN-F) 2.Power cord 3×1.0 mm ² (H05VV-F) 3.Communication Cords	

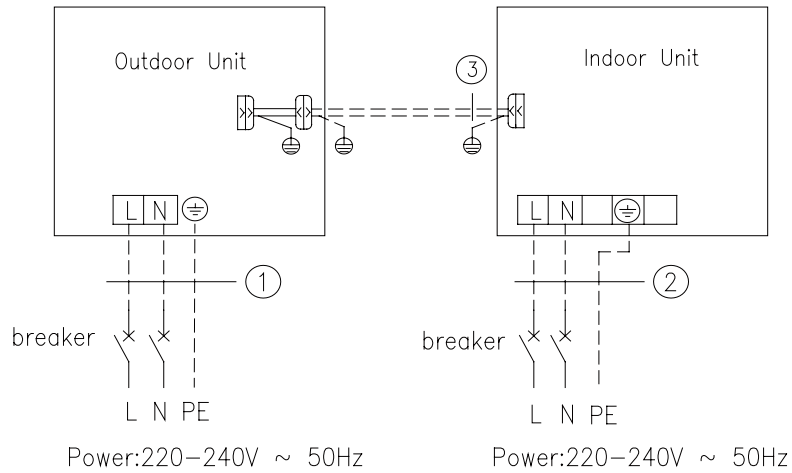

GUHD18NK3CO/ GUHD18NK3C1O + GKH18K3CI GUHD24NK3CO/ GUHD24NK3C1O + GKH24K3CI GUHD30NK3CO/ GUHD30NK3C1O + GKH30K3CI 1.Power cord 3×4.0mm ² (H07RN-F) 2.Power cord 3×1.0 mm ² (H05VV-F) 3.Communication Cords	
---	--

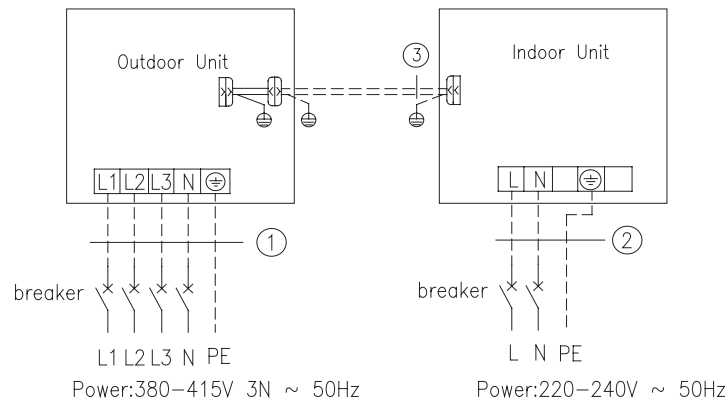

GUHD36NM3CO/ GUHD36NM3C1O + GKH36K3CI GUHD42NM3CO/ GUHD42NM3C1O + GKH42K3CI 1.Power cord 5×2.5mm ² (H07RN-F) 2.Power cord 3×1.0mm ² (H05VV-F) 3.Communication Cords	
---	--

4.3 Specification of Power Supply Wire and Air Switch

Model	Power Supply	Capability of Air Switch(A) (Outdoor/Indoor)	Minimum Sectional Area of Earth Wire (mm ²) (Outdoor/Indoor)	Minimum Sectional Area of power Wire (mm ²) (Outdoor/Indoor)
GUHD09NK3CO/ GUHD09NK3C1O	220-240V 50HZ	16/6	2.5/1.0	2.5/1.0
GUHD12NK3CO/ GUHD12NK3C1O		16/6	2.5/1.0	2.5/1.0
GUHD18NK3CO/ GUHD18NK3C1O		20/6	4.0/1.0	4.0/1.0
GUHD24NK3CO/ GUHD24NK3C1O		20/6	4.0/1.0	4.0/1.0
GUHD30NK3CO/ GUHD30NK3C1O		20/6	4.0/1.0	4.0/1.0
GUHD36NK3CO/ GUHD36NK3C1O		25/6	4.0/1.0	4.0/1.0
GUHD42NK3CO/ GUHD42NK3C1O		25/6	4.0/1.0	4.0/1.0
GUHD48NK3CO/ GUHD48NK3C1O		32/6	6.0/1.0	6.0/1.0
GUHD36NM3CO/ GUHD36NM3C1O	380-415V 3N,50Hz	16/6	2.5/1.0	2.5/1.0
GUHD42NM3CO/ GUHD42NM3C1O		16/6	2.5/1.0	2.5/1.0
GUHD48NM3CO/ GUHD48NM3C1O		16/6	2.5/1.0	2.5/1.0
GUHD60NM3CO/ GUHD60NM3C1O		16/6	2.5/1.0	2.5/1.0

Note:

The parameters of the power cord listed above are only applicable to the BV single-core power cord which is laid within the plastic bushing and used at 40°C, and those of the air switch are applicable to the one which also is used at 40°C. If the actual installation conditions changes, please refer to the instructions of the power cord and the air switch.



MAINTENANCE

MAINTENANCE

1 TROUBLE TABLE

Table 1 Fault Display on Indoor Wired Controller:

Trouble Code	Trouble Name	Origin of Trouble Signal	Control Description
E0	Water Pump Malfunction	Water pump	If the water-full protection cannot be recovered after 2 hours, it is believed that the water pump is failed, in which case all the loads will be switched off and cannot be recovered automatically.
E1	High Pressure Protection of Compressor	High-pressure Switch	When high pressure protection is detected for 3 seconds successively, all the loads (except the heating 4-way valve) will be switched off, in which case all the keys and remote control signals except ON/OFF function will be disabled and cannot be recovered automatically. To eliminate the fault, it is needed to switch off and on the machine or recover from power failure.
E2	Indoor Anti-frozen Protection	Indoor evaporator sensor	If detecting that the evaporator sensor is lower than protective temp. value after the unit has been running for a period of time under cooling or dry mode, the unit will report this fault, in which case the compressor and outdoor fan will be stopped. The unit will not run until this temperature exits the protective temperature value and the compressor is stopped for 3 minutes.
E3	Low Pressure Protection of Compressor	Low-pressure Switch	If it is detected within 30 seconds successively that the low-pressure switch is cut off under ON or standby state (If the compressor is started, the detection will start 3 minutes after the compressor has run), the unit will report this fault. For the first two faults within 30 minutes, the unit can be recovered automatically. If over three times, the unit cannot be recovered automatically.
E4	Air Discharge High-temperature Protection of Compressor	Exhaust Over temperature Protection	After the compressor is started, if it is detected within 30 seconds successively that the exhaust temperature is 130°C or higher, E4 will be displayed, in which case all the loads (except the 4-way valve of heating) will be stopped. The complete unit can only be recovered until the compressor has stopped for 3 minutes and the exhaust temperature is lower than 90°C. For this protection occurs three times, the complete unit cannot be recovered automatically.
E5	Compressor Overload or drive error	Compressor	After the unit is energized, if it is detected within 3 seconds successively that the compressor overload switch is cut off, it will be deemed compressor overload protection. In this case, all the loads will be stopped (except the 4-way valve of heating) and E5 will be displayed. If the fault is eliminated, the compressor will be restarted after 3 minutes. If three compressor overload protections are detected successively in 30 minutes from the first detection to the occurrence of fault, the compressor cannot be recovered automatically and the buzzer will alarm. You shall need to press ON/OFF to stop the unit and clear the sound alarm before pressing ON/OFF again. The unit will be restarted if the high pressure protection disappears; otherwise the fault code will be displayed. Besides, "E5" also will also be displayed on the controller in the event of an error of the compressor drive module.
E6	Communications Failure	Communication between indoor and outdoor mainboard	If the outdoor unit does not receive data from indoor unit for 30 seconds successively once energized, this indicates indoor communication failure. In this case, the compressor and outdoor fan will be stopped. Under heating mode, the 4-way valve will be stopped if the compressor has been stopped for 2 minutes. If the indoor unit does not receive message from outdoor unit for 1 minute, this indicates communication failure. In this case, the indoor unit will be stopped and the indicator will blink. If the display board does not receive message from outdoor unit in 1 minute, it can be judged that it is communication failure, in which case the fault will be displayed and the machine will not function. After the communication is resumed to normal, the system will run as per the working mode before. This can recover automatically.

Trouble Code	Trouble Name	Origin of Trouble Signal	Control Description
E9	Full Water Protection	Liquid level switch	If "full water" is detected for 8 seconds successively once energized, the system will enter into full water protection and the indicator will blink (or display E9): Under cooling and dry mode, the outdoor fan and compressor will be stopped, while the indoor fan will be stopped after 1 minute. Under heating mode, the outdoor fan and compressor will be stopped, the 4-way valve will maintain its original state, and the indoor unit will be stopped after 1 minute. Under fan mode, the indoor loads will not be stopped.
F0	Malfunction of Indoor Environment Sensor at Return air Vent	Indoor room sensor	If the indoor sensor is detected of open circuit or short circuit for 5 seconds successively, the indoor room temperature will forcibly set to 24°C. In this case, the system will not perform any treatment, only the indicator will blink or display the fault code. The system can automatically resume after the failure is eliminated. Under fan mode, only the fault will be displayed, but the indoor unit will run normally. The fault disappears after it is eliminated.
F1	Evaporator Temp. Sensor Malfunction	Outdoor evaporator sensor	If the evaporator sensor is detected of open circuit or short circuit for 5 seconds successively: When under cooling and dry mode, the system will be stopped. When under heating mode, all of the loads except the 4-way valve will be stopped, while the indicator will blink or display the fault code F1. After the fault is eliminated, the system can automatically resume to operation and clear the fault display. Under fan mode, only the fault will be displayed, and the indoor unit will run normally. The fault disappears after it is eliminated.
F2	Condenser Temp. Sensor Malfunction	Outdoor condenser sensor	If the condenser sensor is detected of open circuit or short circuit for 5 seconds successively: When under cooling and dry mode, the system will be stopped. When under heating mode, all of the loads except the 4-way valve will be stopped, while the indicator will blink or display the fault code F2. After the fault is eliminated, the system can automatically resume to operation and clear the fault display. Under fan mode, only the fault will be displayed, and the indoor unit will run normally. The fault disappears after it is eliminated. For cooling-only unit, the other units except the duct type will not detect the condenser sensor fault.
F3	Outdoor Environment Sensor Malfunction	Outdoor environment sensor	If the outdoor environment sensor is detected of open circuit or short circuit for 5 seconds successively: When under cooling and dry mode, the system will be stopped. When under heating mode, all of the loads except the 4-way valve will be stopped, while the indicator will blink or display the fault code F3. After the fault is eliminated, the system can automatically resume to operation and clear the fault display. Under fan mode, only the fault will be displayed, and the indoor unit will run normally. The fault disappears after it is eliminated.
F4	Malfunction of Exhaust Temp. Sensor	Exhaust temperature sensor	If the outdoor temperature sensor is detected of open circuit for 5 seconds successively after the compressor is started: When under cooling and dry mode, all the loads will be stopped. When under heating mode, all of the loads except the 4-way valve will be stopped, while the indicator will blink or display the fault code F4 and the buzzer will alarm. After the fault is eliminated, the system can automatically resume to operation and clear the fault code. If the outdoor temperature sensor is detected of short circuit: When under cooling and dry mode, all the loads will be stopped. When under heating mode, all of the loads except the 4-way valve will be stopped, while the indicator will blink or display the fault code F4 and the buzzer will alarm. After the fault is eliminated, the system can automatically resume to operation and clear the fault code.
F5	Malfunction Of Indoor Environment Sensor at Wire Controller	Wired controller	If the wired controller is detected of open circuit or short circuit for 5 seconds successively, the indoor room temperature will forcibly set to 24°C. In this case, the system will not perform any treatment, only the indicator will blink or display the fault code. The system can automatically resume to operation after the failure is eliminated. Under fan mode, only the fault will be displayed, but the indoor unit will run normally. The fault disappears after it is eliminated.

Trouble Code	Trouble Name	Origin of Trouble Signal	Control Description
FF	All of The Terminal Air Valve Colsed (not failure)	System	The air valve on end will be fully closed.
CC	Wire Controller Invalid (not failure)	wire controller	the units is remotely monitored or controlled by centralized controller and the wire controller's functions are invalidated (not failure)
EE	Keys Locked (not failure)	wire controller	keys on wire controller are locked (not failure)

Table2.Cassette Type Indoor Unit's Error Indicating

LED	No error	Flash times every two seconds	Error description
yellow: Timing indicating lamp	It goes on as per the set time, And it flashes when the temperature sensor error occurs	once	the indoor ambient temperature sensor error
		twice	the evaporator temperature sensor error
		three times	the condenser temperature sensor error
		four times	the outdoor ambient temperature sensor error
		five times	the discharge air temperature sensor error
green:Compressor indicating lamp	It goes on/off as the compressor is turned on/off. And it flashes when defrosting or the compressor error occurs	twice	Defrosting
		three times	high pressure protection
		four times	the low pressure protection
		five times	Overload protection
		six times	Discharge high temperature protection
red:Running indicating lamp	It goes on/off as the unit is turned on/off, And it flashes when the indoor unit error occurs	once	Communication error
		twice	the water overflow protection
		three times	the anti-freezing error
		four times	Anti-high temperature protection

Floor Ceiling Type LED board

Note:

If the floor ceiling type unit has LED board, then no wired remote controller.

There is one red LED, one green LED, one yellow LED, two nixie lights on the LED board.

a. RED LED

It is on when power is on.

It is off when power is off.

b. GREEN LED

It is on during running of cool mode.

It is off when the unit is not at cool mode.

c. YELLOW LED

It is on during running of heat mode.

It is off when the unit is not at heat mode.

d. Nixie Lights

When there is no error, it will display the temp setup for 5s, then display the temp of indoor.

When the unit has error,it will display error code,

Its error code as the same as Table 1 Fault Display on Indoor Wired Controller.

Table3 This section is applicable to the electric control box of the outdoor unit 09~12K .

NO	Running Status	Yellow Lamp	Red Lamp	Green Lamp	
1	Compressor started	Flash once			
2	Defrosting	Flash twice			Displayed
3	Anti-freezing protection	Flash 3 times			E2
4	IPM protection	Flash 4 times			E5
5	Over-current protection	Flash 5 times			E5
6	Heat exchanger overload protection	Flash 6 times			/
7	Discharge protection	Flash 7 times			E4
8	Compressor overload protection	Flash 8 times			E5
9	Power protection	Flash 9 times			E5
10	Module overheating protection	Flash 10 times			E5
11	EEPROM reading error	Flash 11 times			E5
12	Low voltage protection	Flash 12 times			E5
13	High voltage protection	Flash 13 times			E5
14	PFC over-current protection	Flash 14 times			E5
15	Unmatched indoor and outdoor units	Flash 16 times			/
16	Limited frequency(current)		Flash once		/
17	Limited frequency (discharge)		Flash twice		/
18	Limited frequency (overload)		Flash 3 times		/
19	Reduced frequency (anti-freezing)		Flash 4 times		/
20	Outdoor ambient temperature sensor error		Flash 6 times		F3
21	Outdoor pipe temperature sensor error		Flash 5 times		F2
22	Outdoor discharge temperature sensor error		Flash 7 times		F4
23	Up to the startup temperature		Flash 8 times		/
26	Limited frequency (module temperature)		Flash 11 times		/
28	Limited frequency (power)		Flash 13 times		/
31	Communication normal			Flash continuously	/
32	Communication error			Black out	E6
33	Indoor ambient temperature sensor error				F0
34	Indoor pipe temperature sensor error				F1

Table 4 Main board dual 8 numeral tube Display Codes for Outdoor Unit of 18~60k

Malfunction Item	Outdoor unit display of dual 8 numeral tube	Indoor Unit Display
DC busbar over-voltage protection	PH	E5
IPM or PFC over-temperature protection	P8	E5
Current sense circuit error	Pc	E5
IPM or PFC temperature sensor error	P7	E5
Compressor current protection	P5	E5
DC busbar under-voltage protection	PL	E5
Compressor startup failure	Lc	E5
PFC protection	Hc	E5
Drive module reset	P0	E5
Compressor motor desynchronizing	H7	E5
Phase loss	Ld	E5
Drive-to-main-control communication error	P6	E5
IPM protection	H5	E5
High-pressure protection	E1	E1
Low-pressure protection	E3	E3
Exhaust protection	E4	E4
Compressor overload protection	H3	E5
Communication malfunction (among indoor unit, outdoor unit and wired controller)	E6	E6
Outdoor ambient temperature sensor malfunction	F3	F3
Coil pipe intermediate temperature sensor malfunction of outdoor unit	F2	F2
Exhaust temperature sensor malfunction	F4	F4
Defrosting (non-malfunction)	08	defrost
Oil return (non-malfunction)	09	no display
Mismatch of indoor unit model	LP	no display
AC current protection (input side)	PA	E5
Input AC voltage abnormality	PP	E5
Charging circuit error	PU	E5
DC fan error	H6	E5

2 FLOW CHART OF TROUBLESHOOTING

2.1 System Troubleshooting

Service personnel shall collect the malfunction information as much as possible and research them thoroughly, list these electrical parts which may cause malfunction, service personnel shall be able to determine the specific reason and solve the faulted parts.

Observe the status of the complete device and do not observe the partial

It is advised to start from the simple operation during analyzing, judging and confirming malfunction reason, then conduct the complicated operations such removal of device, part replacement and refrigerant filling.

Find the malfunction reason carefully as unit may occur several malfunction at the same time and one malfunction may develop into several malfunction, so entire system analysis shall be established to make the judged result exact and credible.

- Malfunction display: E1 Compressor High Pressure Protection

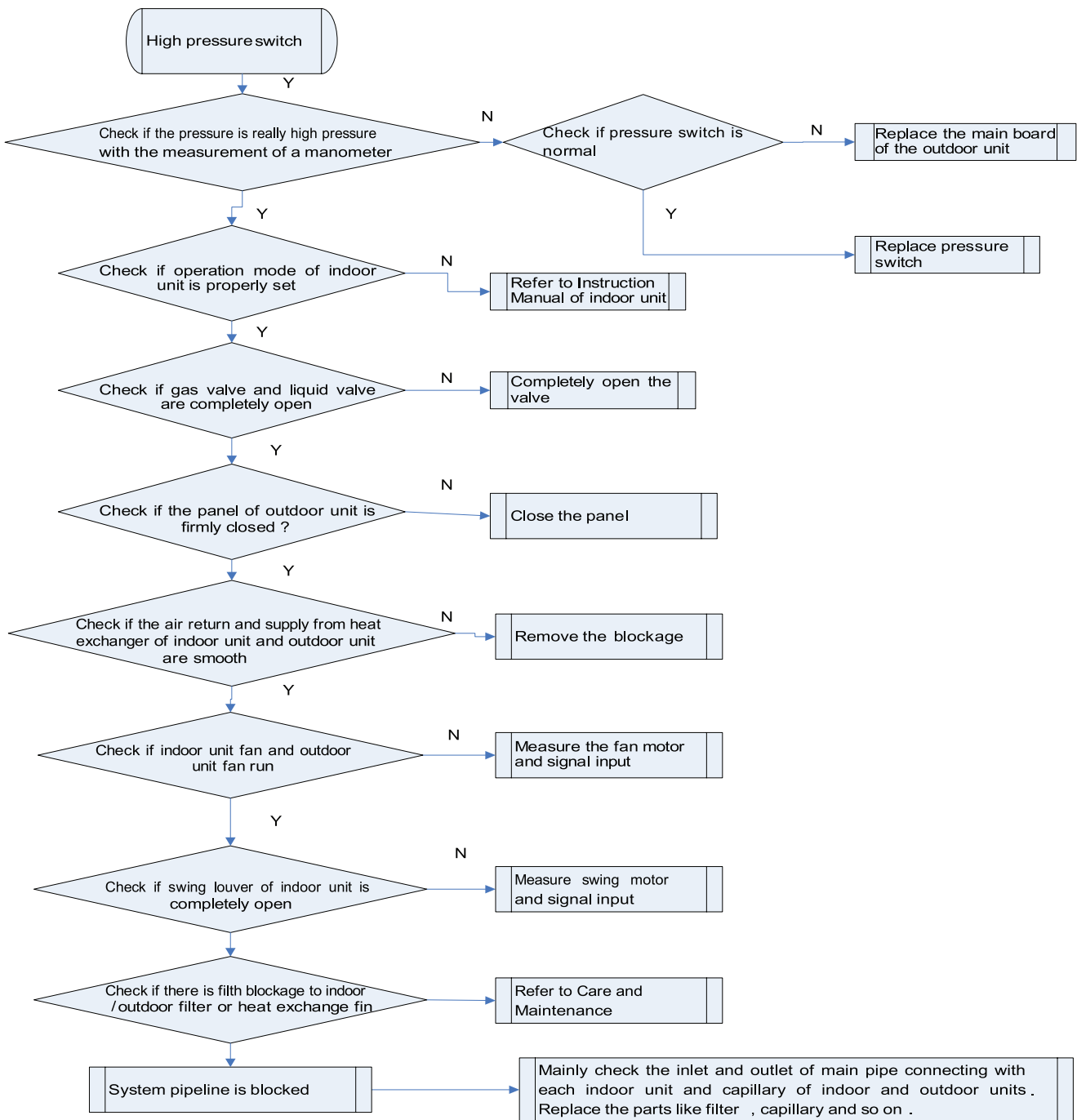

● Malfunction display: E3 Compressor Low Pressure Protection

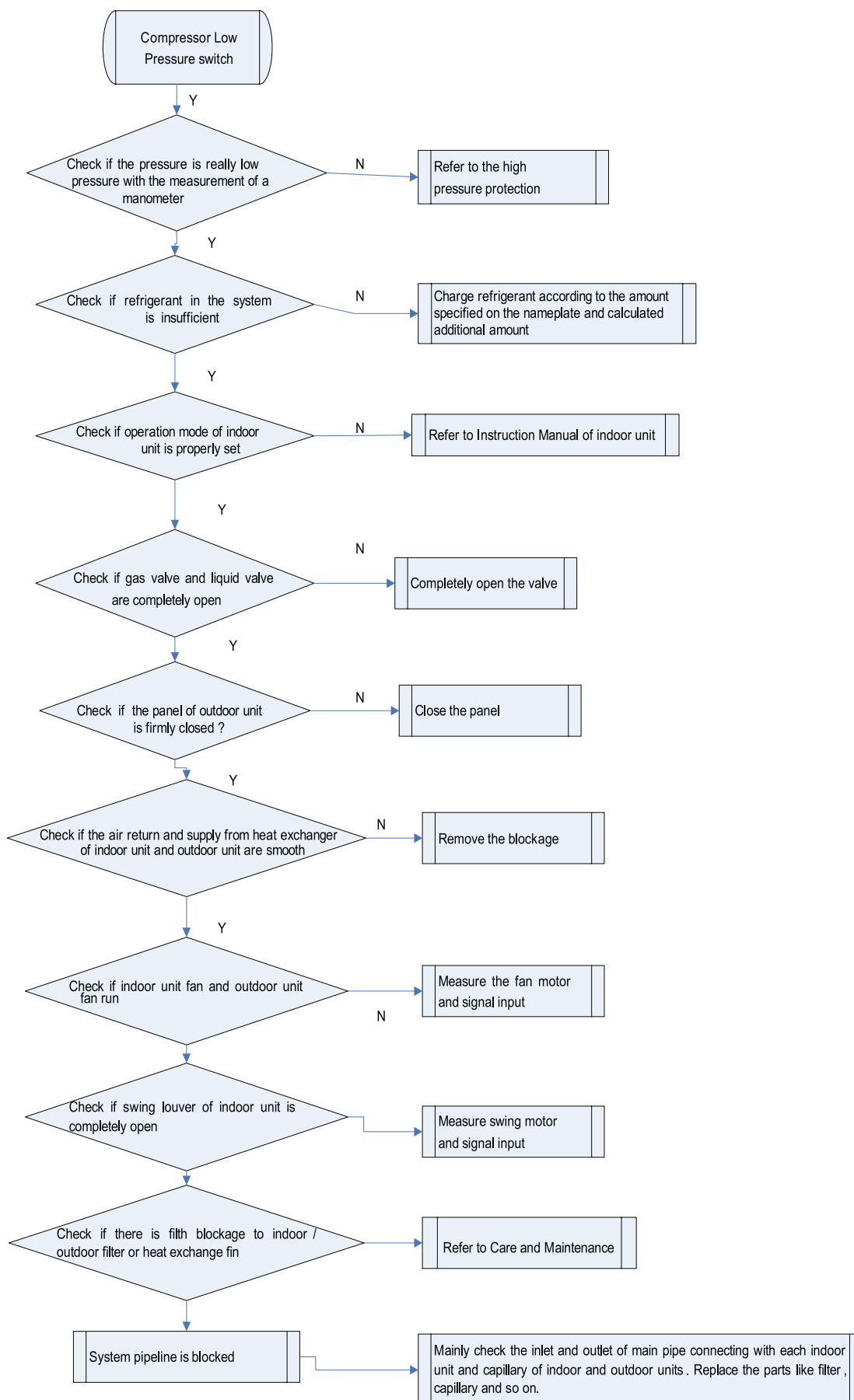

- Malfunction display: E4 Compressor Exhaust High Temperature Protection

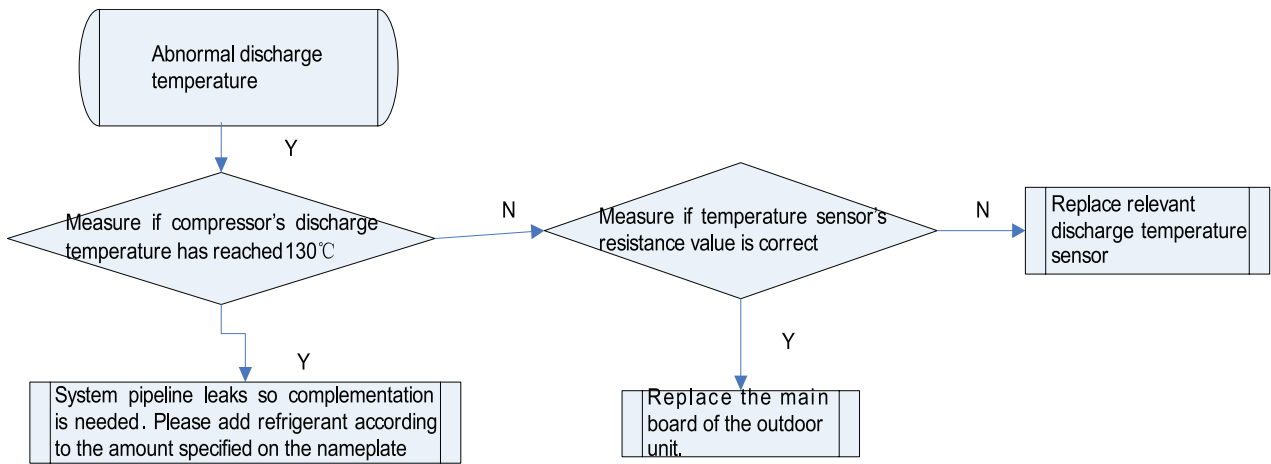

- Malfunction display: E5 Compressor Overheat (Please check the corresponding method of drive protection)

- Malfunction display: E6 Communications Failure

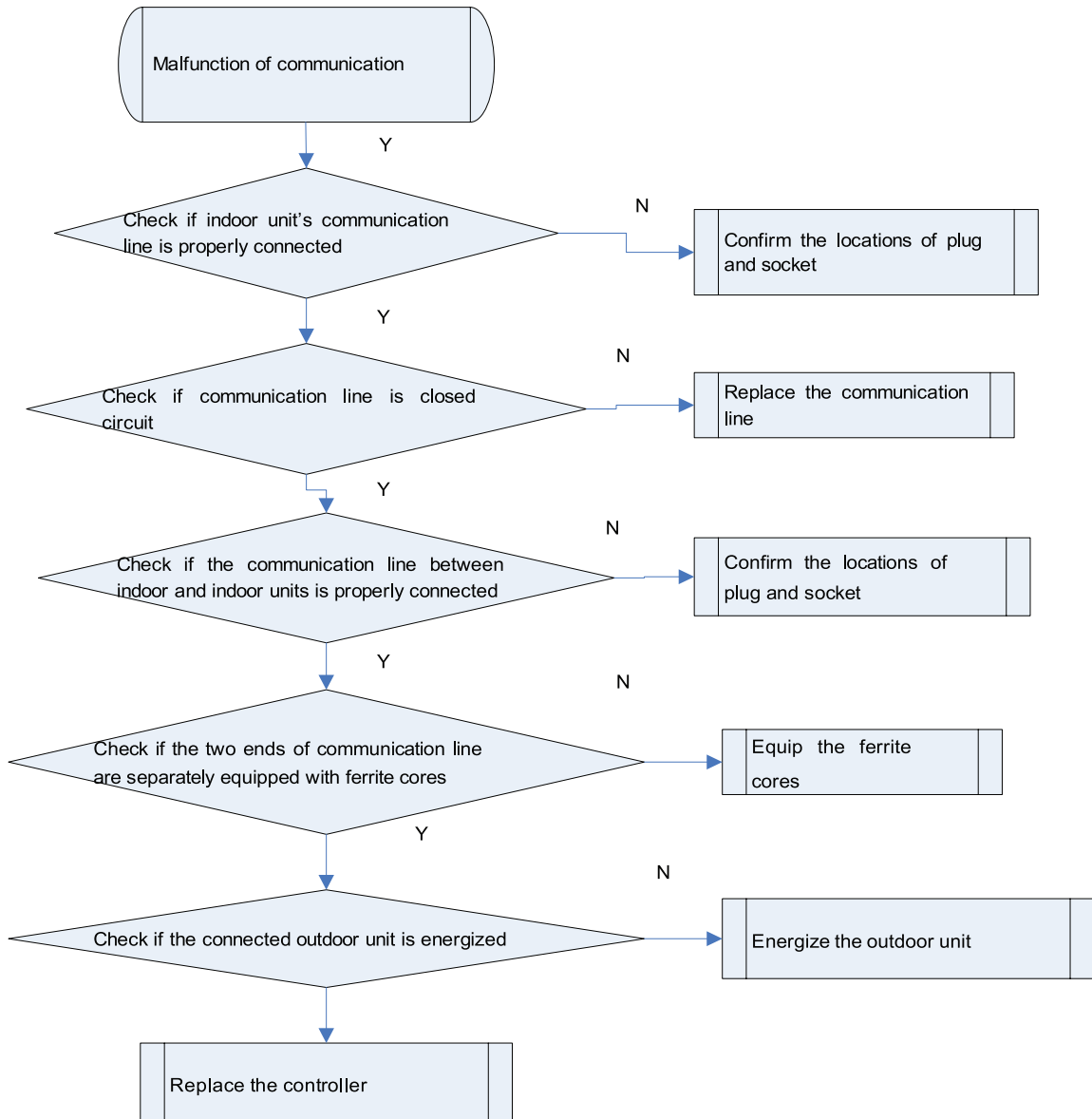

• Malfunction display: E9 Full Water Protection

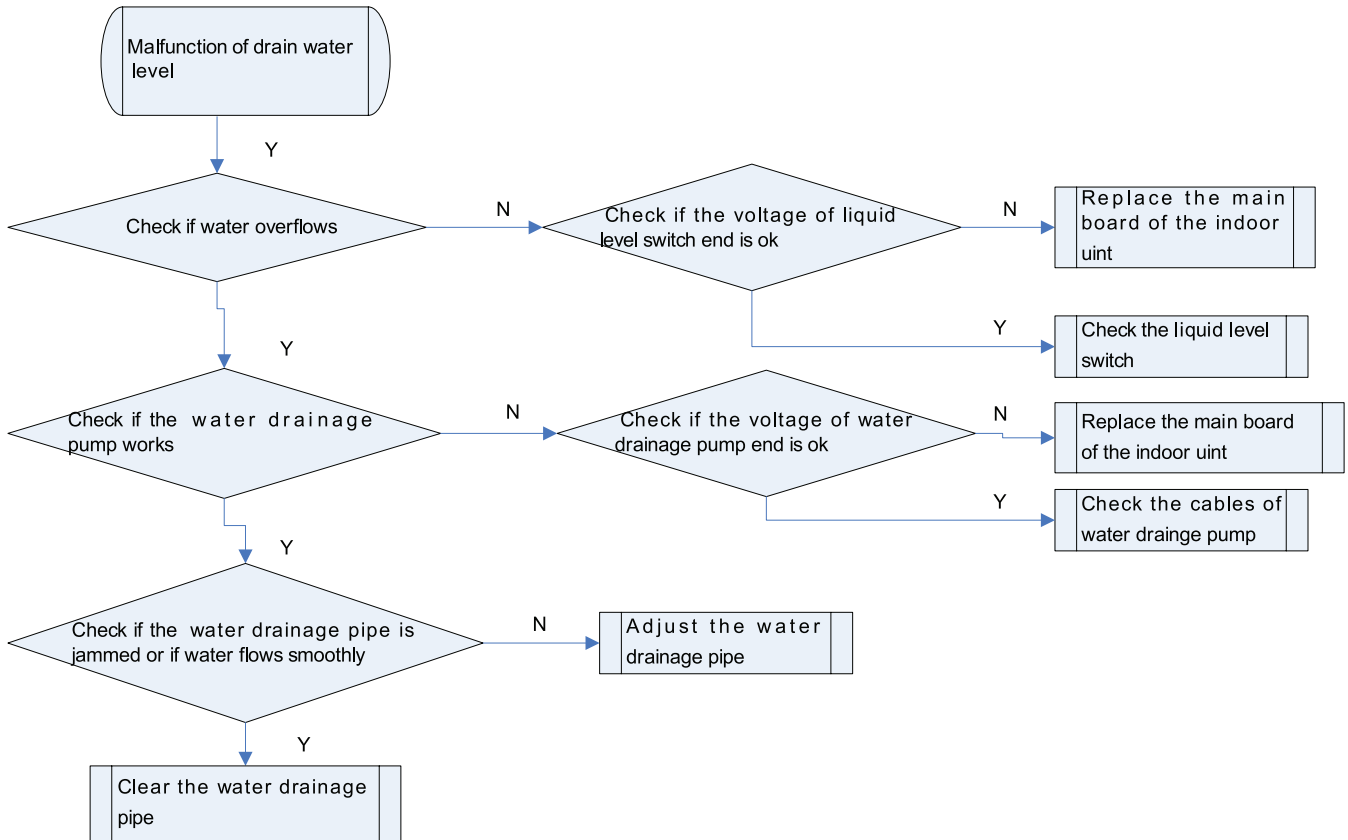

• Malfunction display: F0 Failure of Indoor Room Sensor at Return air inlet

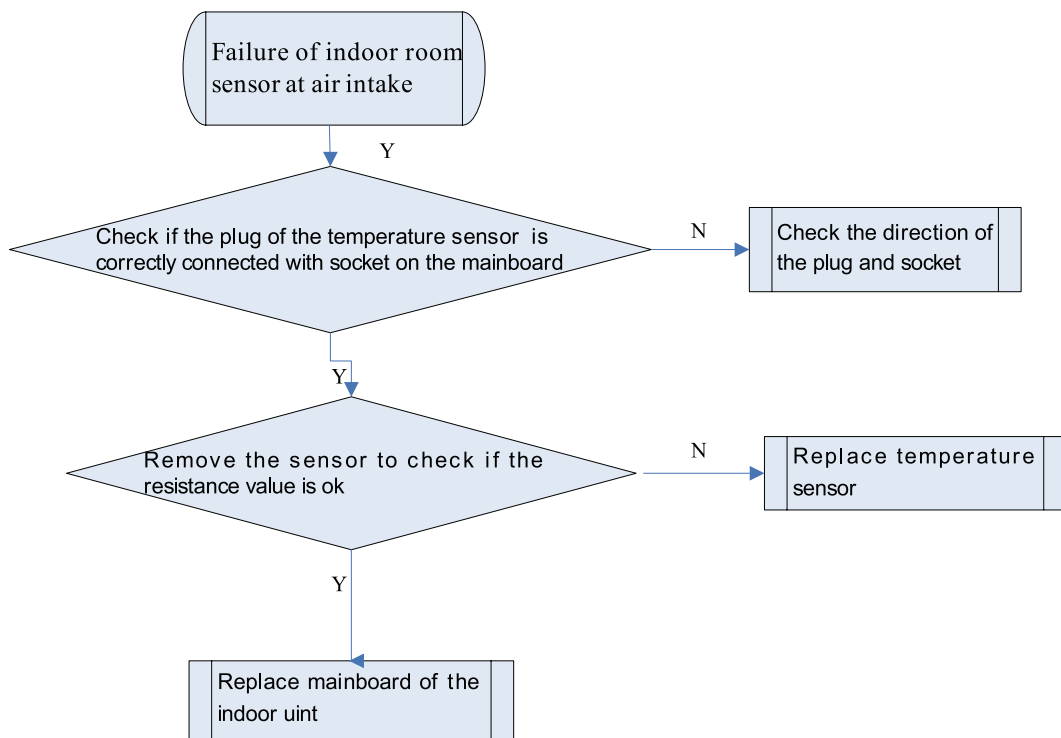

• Malfunction display: F1 Failure of Evaporator Temp. Sensor

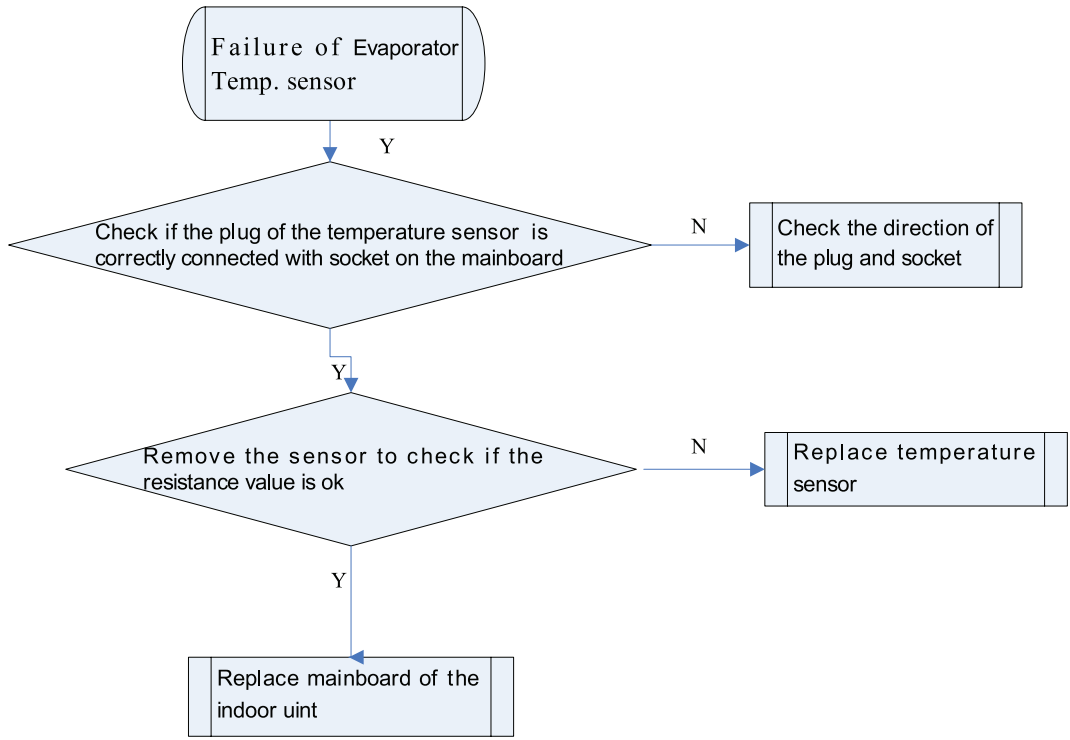

• Malfunction display: F2 Failure of Condenser Temp. Sensor

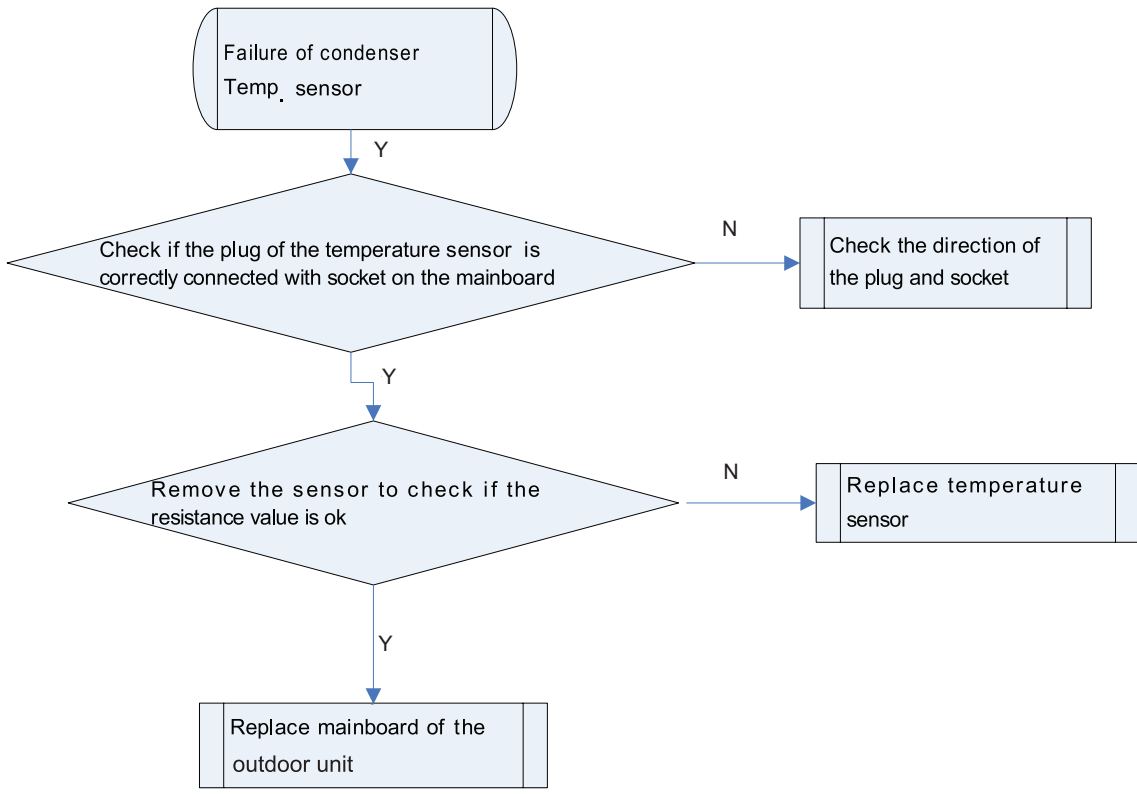

• Malfunction display: F3 Failure of Outdoor Ambient Sensor

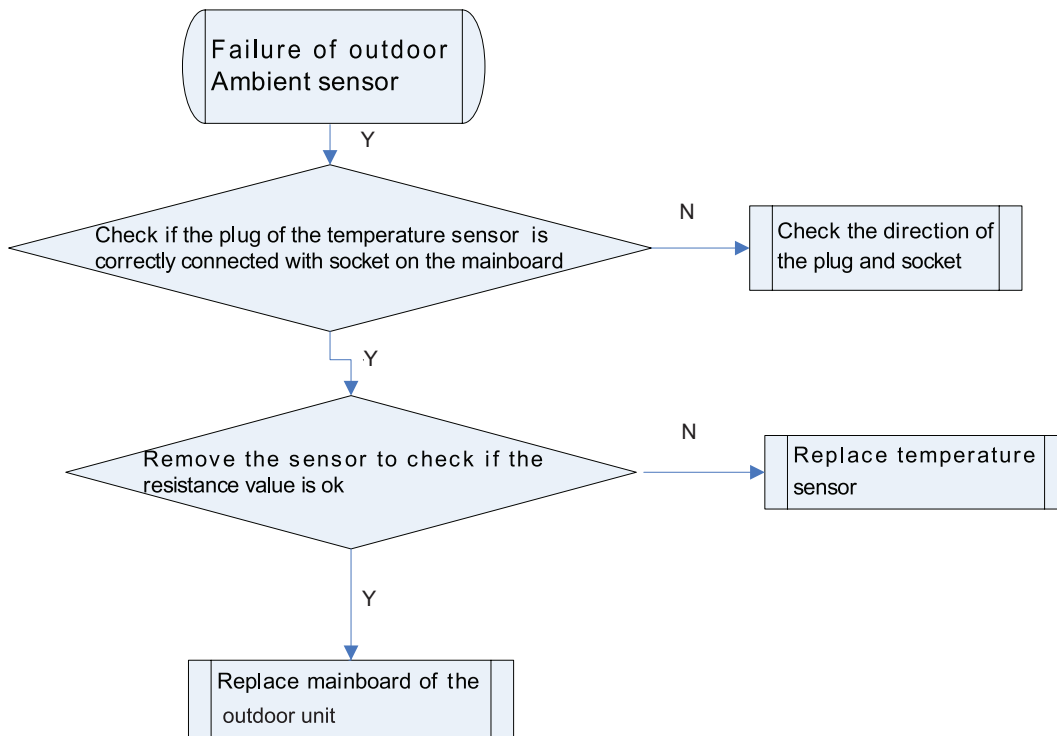

• Malfunction display: F4 Failure of Exhaust Temp. Sensor

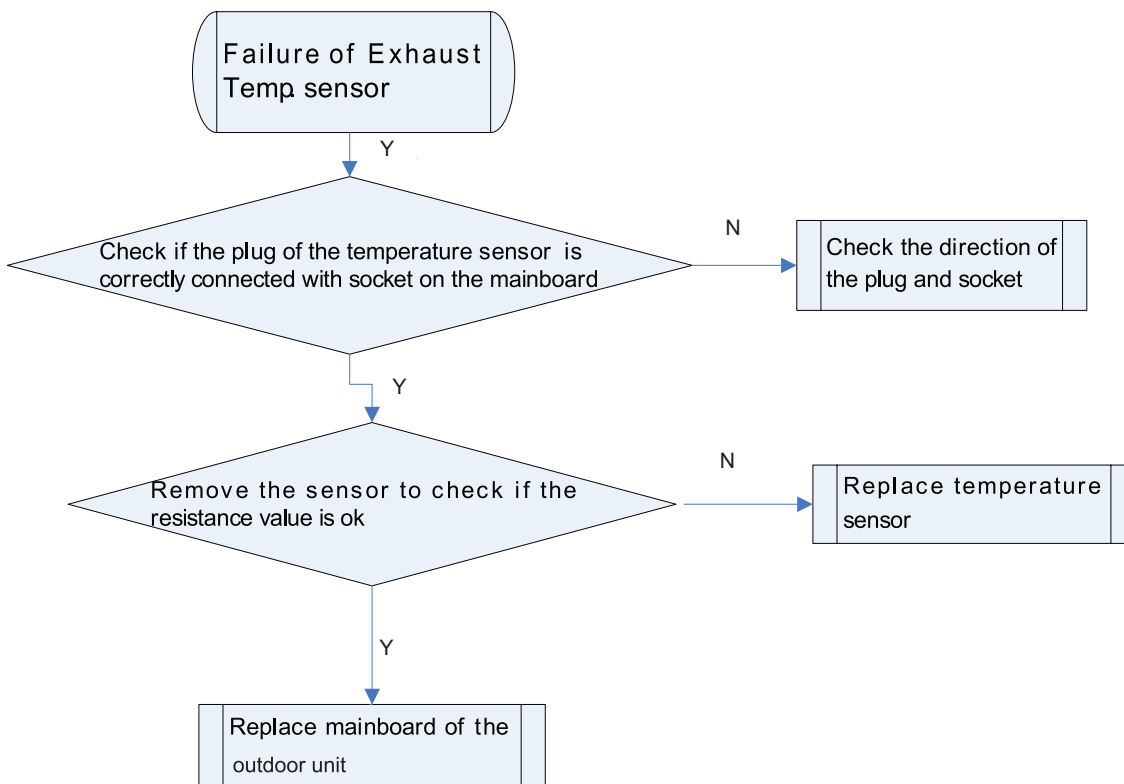

- Malfunction display: F5 Failure of Indoor Room Sensor at Wire Controller

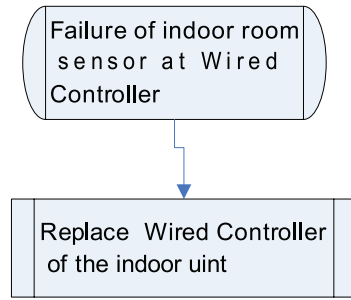

2.2 Typical Troubleshooting for C series Outdoor Unit Drive (Inverter) by Single-phase Motor

2.2.1 Brief Introduction to the Electric Control Box of the Outdoor Unit .(Applicable to 09~12K)

1.Schematic of Outdoor Unit Electric Control Box (Control board on the left; filter plate board on the right)

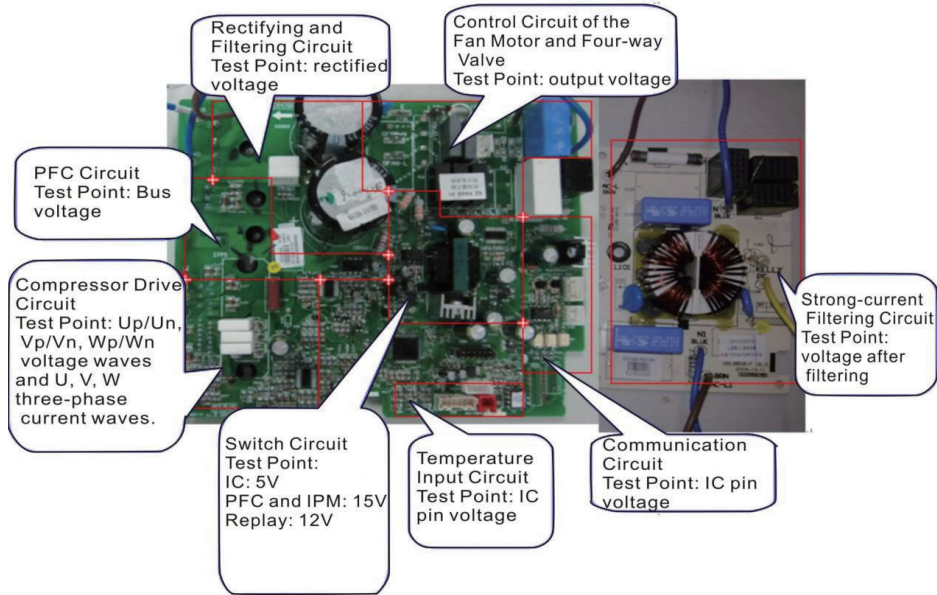

2. Testing Method to the Key Points on the Outdoor Unit's Electric Control Box

2.1 Test Points and Testing Method of 15V/12V/5V Power Supplies.

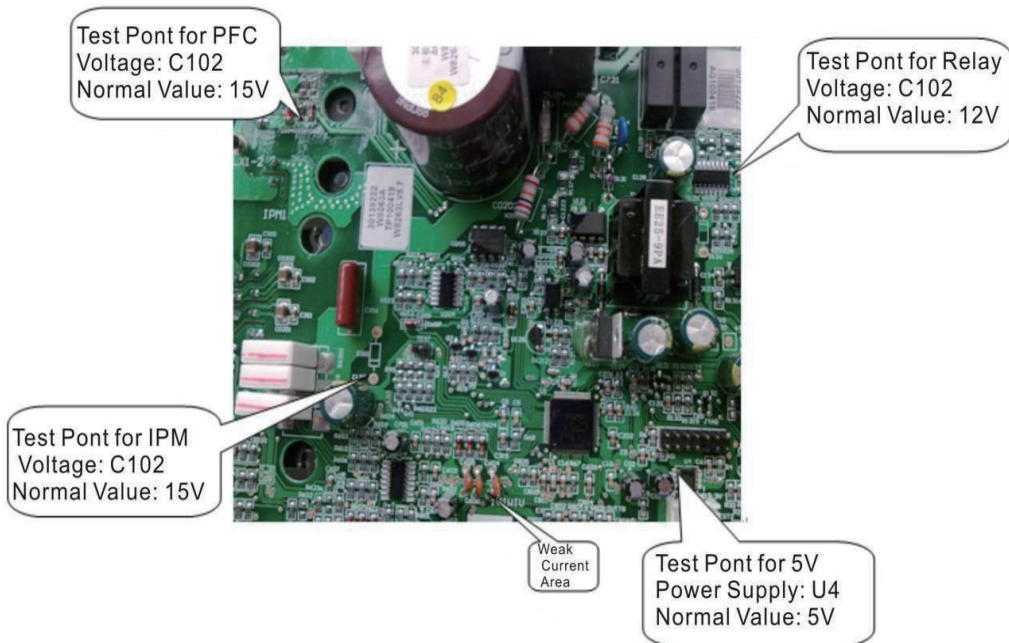

2.2 Test Points and Testing Method of 5V and 3.3V Power Supplies.

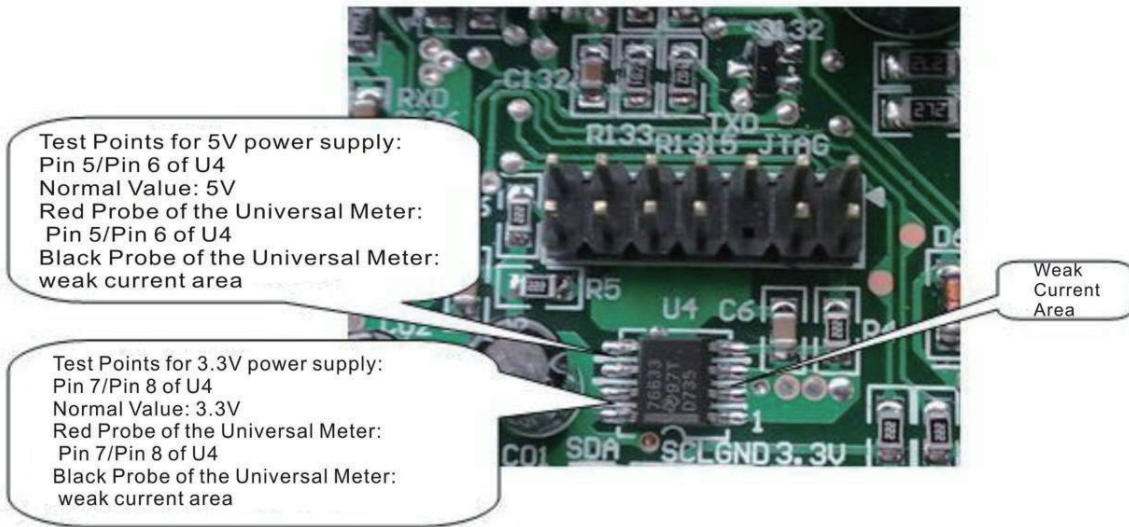

2.3 Test Points and Testing Method of IGBT and IPM Module

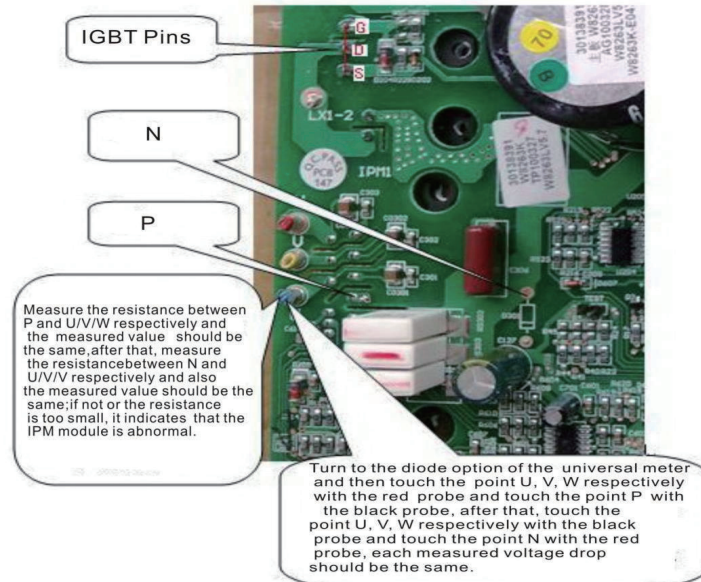

2.4 Test Points and Testing Method of the Rectifier

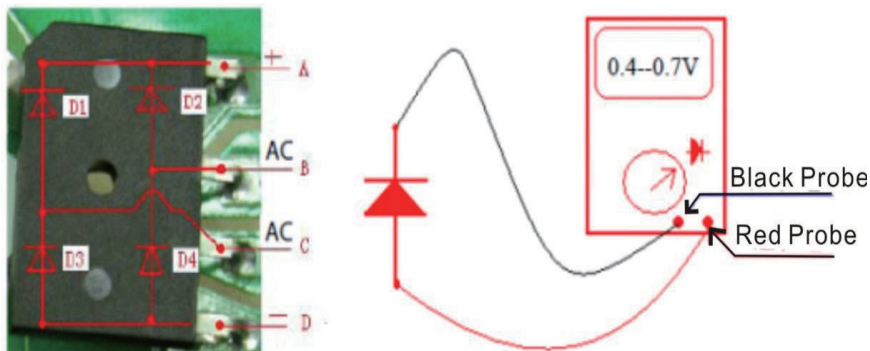

3 Status Indicating Lamp of the Electric Control Box of the Outdoor Unit

There are three independent indicating lamps on the electric control box of the outdoor unit, and they will flash on for five seconds and then black out for another five seconds, which is called a round. Once the lamp blacks out for more than 1 seconds, it means this round is over and the next round begins as it flashes on again.

2.2.2 Analysis to the Common After-Sales Faults

1. Stalling of the Outdoor Fan Motor

Method of testing the AC fan motor: pull out the terminals of the fan motor, then measure the resistance between the red, brown, and black wires with the universal meter; the normal resistance is several hundreds ohms, if not, it indicates there is an open circuit and the fan motor is defective.

If the measured resistance of the fan motor is abnormal, please replace the fan motor; if not, please replace the control of the outdoor unit.

2. Temperature Sensing Fault

This fault can be confirmed according to the error code displayed on the indoor unit.

Replace the corresponding temperature sensor according to the error code. If possible, pull out the temperature sensor and measure the resistance between its two ends to see if it is defective or not.

If the fault still exists after the replacement of the temperature sensor, then please replace the electric control box of the outdoor unit.

3. IPM Protection(H5)

a. Pull out the power plug for three minutes and then plug it again, in which case, if H5 appears in no time, check if the terminals of the compressor are improperly connected or loosened; if not, replace the electric control box of the outdoor unit; if the fault still exists, then it indicates the compressor is defective and should be replaced.

b. When H5 appears after the unit has run for a period of time, then it is necessary to see if the running environment is really bad (e.g. the condenser is blocked with filth). If not, there is a need of a further check to see if the wiring of the compressor is reverse, the screws of the module is tightened, or if the compressor is defective etc; If the fault is beyond the statement above, please replace the electric control box of the outdoor unit.

4. Heating Failure

1. Under the heating status, measure the voltage between two wires of the four-way valve with a universal meter. The testing points are 4V and AC-L2. If the measured voltage is not about AC230V, then it indicates that the electric control box of the outdoor unit is defective and should be replaced.

2. If the measured voltage is about AC230V, then cut off the power supply and pull out these two wires of the four-way valve and measure the resistance between the test points to see if it is about 1-2K. If it is much larger, it indicates that there is an open circuit among the coils of the four-way valve which then should be replaced.

3. If the coils of the four-way valve is normal, then the failure may be caused by the system abnormality.

5. Cooling Failure

The cooling failure is posed generally when the Relay K5's contactor of the four-way valve of the outdoor unit's electric control box is bonded, and it can be checked out by the universal meter.

2.2.3 Solutions to the Unsolved Faults after the Replacement of the Electric Control Box

1. After the Replacement of the Electric Control Box of the Outdoor Unit

If the faults still exist after the replacement of the electric control box of the outdoor unit, please take a check to see if the communication line, temperature sensor, reactor, fan motor, or compressor is normal or not.

Communication line: check if the communication line, live line, or neutral line are connected improperly or the contactor of the terminals are not good. If the line is extended, then check if the joint is in good condition.

Temperature sensor: measure the grounding resistance between the points 3.3V and IPM15V (the testing method is same as above); if the grounding is shortcut, please check if each temperature sensor is damaged or if there is arcing trace on its outer housing or metal ends

Reactor: if the communication error remains after the replacement of the electric control box, then pull out the two terminals of the reactor and measure the resistance between them with a universal meter; if the measure valve is about several ohms, it indicates the terminals of the reactor is likely to break off.

Fan motor: pull out the terminals of the fan motor and measure the resistance between the red, brown

and black wires with a universal meter; The normal value is about several hundreds ohms, if the measure value is beyond this range, it indicates there is a open circuit or the fan motor is defective.

Compressor: apart from the badly running environment, improper connection, or systematic abnormality, if H5 still occurs frequently after the replacement of the electric control box, then it indicates that the compressor is probably defective.

Four-way valve: pull out two purple wires and measure the resistance between them with a universal meter to see if it is about 1~2K. If it is much larger, it indicates that there is a open circuit among the coils of the four-way valve which then should be replaced.

If the fault is beyond the statement above, then please check the indoor unit.

2 .After the Replacement of the Electric Control Box of the Indoor Unit

If the fault remains after the replacement of the electrical control box of the indoor unit, then there is a need to check if the wiring is proper and the fan motor and temperature sensor is in good condition. Besides, if the fault is beyond the statement above, please check the outdoor unit.

2.2.4 Precautions

1. Prior to the replacement of the main board of the outdoor unit's control box, it must be certain that it is the qualified product and necessary tests as follows should be taken:

- a, test if there is a short circuit between any two of three IGBT pins. If so, the main board can not be used.
- b. test if there is a short circuit between the points P and N of the DC bus. If so, the main board can not be used.
- c. test if there is a short circuit between any U/V/W and P, U/V/W and N. If so, the main board can not be used.
- d. see the section 1.2.3 for the test point and testing method of IGBT and IPM module.

2. Each compressor is matched with only certain type main board of the electric control box, so prior to the replacement of the main board, it must be sure what model the main board is; otherwise the main board would fail to match with the compressor.

3 .As for the replacement of the compressor, it also must be sure what model the compressor is (it can be found on the label of the fan motor capacitor); otherwise the compress would failed to match with the piping system and the electric control box.

4. Never allow any wire to contact the pipes, four-way valve, compressor, and sharp edge of the metal sheet. And the earth leads of the compressor, fan motor and electric control box must be inside a separate screw hole.

5. Necessary measurers should be taken to against water, moisture and static electricity. Besides, during the dismantlement and installation of the electrical control box, a antistatic strip must be put on and do not touch the component as much as possible.

6.The wiring should be done strictly according to the wiring diagram labeled on the electric control box and each wiring terminal should be on the right place. Besides the wires can not be stretched too tightly or else it would break away from the socket, connector or the insulating bushing. The bonding tie should be kept 3mm-5mm long, as the longer one would cause unusual sound by the friction with the cover plate.

2.3 Typical Troubleshooting for C series Outdoor Unit Drive (Inverter) by Single-phase Motor

(Applicable to GUHD18NK3CO/GUHD24NK3CO/ GUHD30NK3CO/ GUHD36NK3CO/ GUHD42NK3CO/ GUHD48NK3CO/GUHD18NK3C1O/GUHD24NK3C1O/ GUHD30NK3C1O/ GUHD36NK3C1O/ GUHD42NK3C1O/ GUHD48NK3C1O)

- P0 Drive module reset
- P7 IPM or PFC temperature sensor error
- PA AC current protection (input side)
- PC Current sense circuit error
- Hc PFC protection

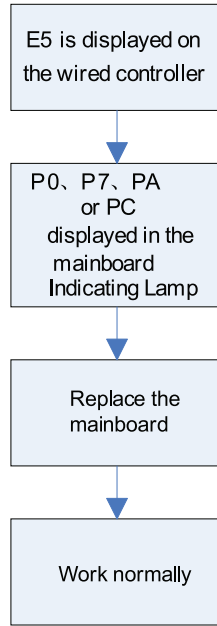

- P8 IPM or PFC over-temperature protection

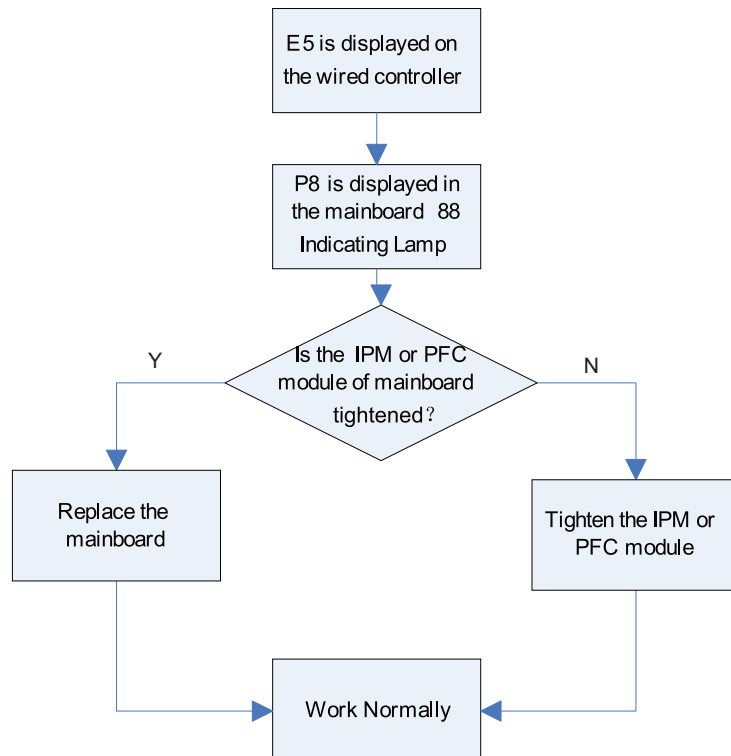

- PH DC busbar over-voltage protection
- PL DC busbar under-voltage protection

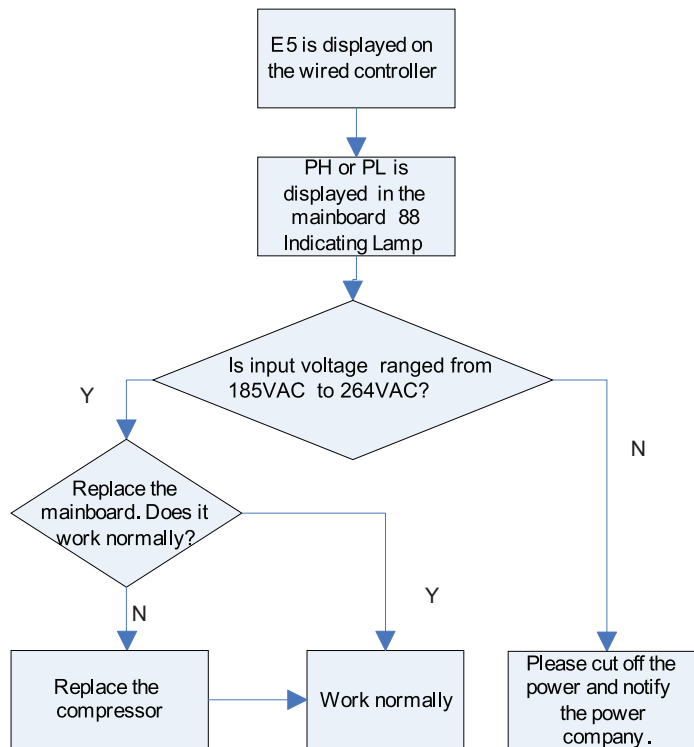

- P6 Drive-to-main-control communication error

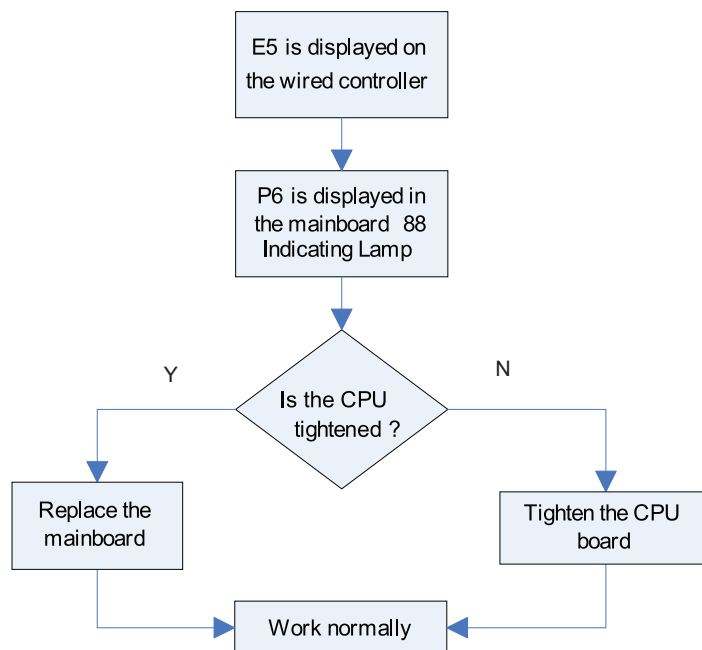

- Lc Compressor Startup Failure

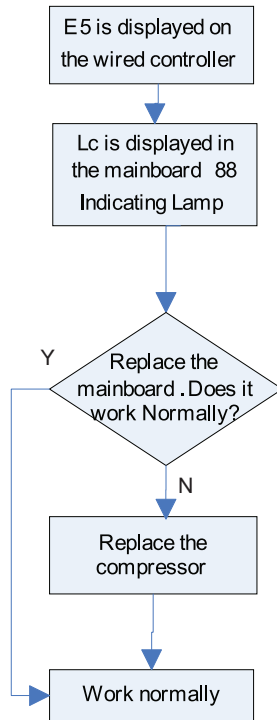

- P5 Compressor current protection
- H7 Compressor motor desynchronizing
- H5 IPM protection
- Ld Phase loss

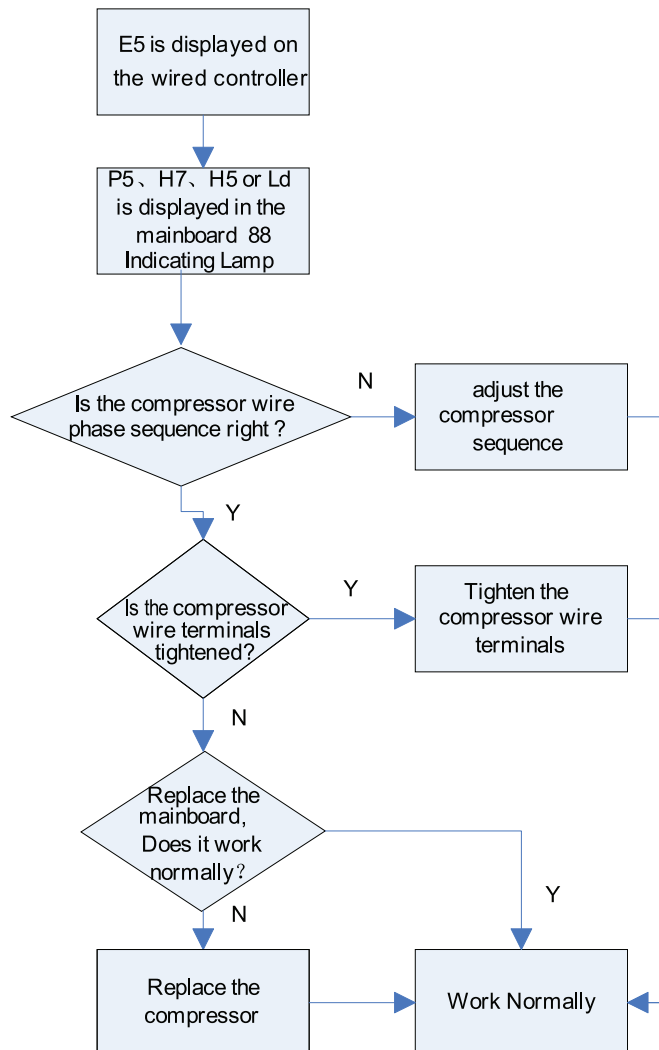

• PU Charging circuit error

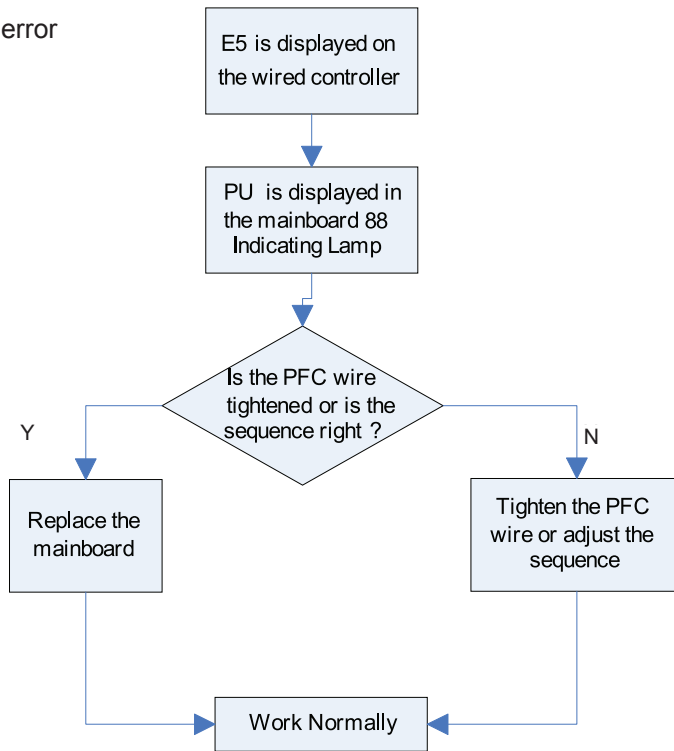

• H6 DC fan error

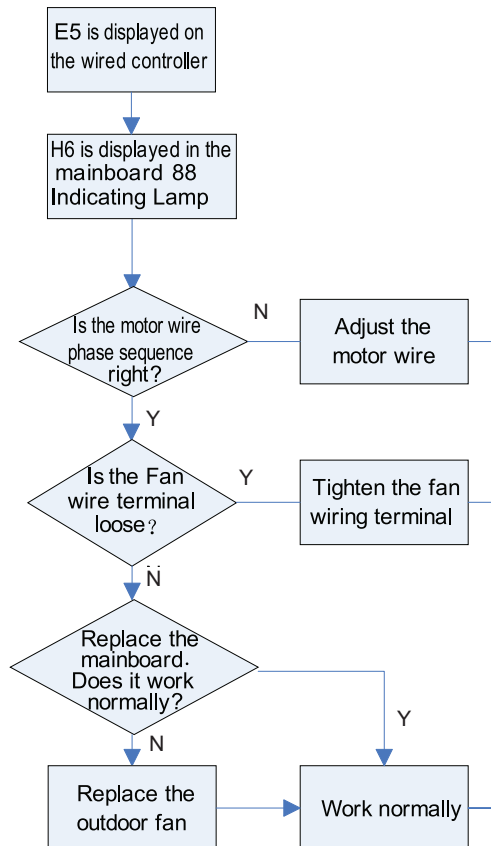

2.4 Typical Troubleshooting Outdoor Unit Drive (Inverter) by Three-phase Motor

(Applicable to GUHD36NM3CO/ GUHD42NM3CO/ GUHD48NM3CO/ GUHD60NM3CO/
GUHD36NM3C1O/ GUHD42NM3C1O/ GUHD48NM3C1O/ GUHD60NM3C1O)

- IPM Module Protection

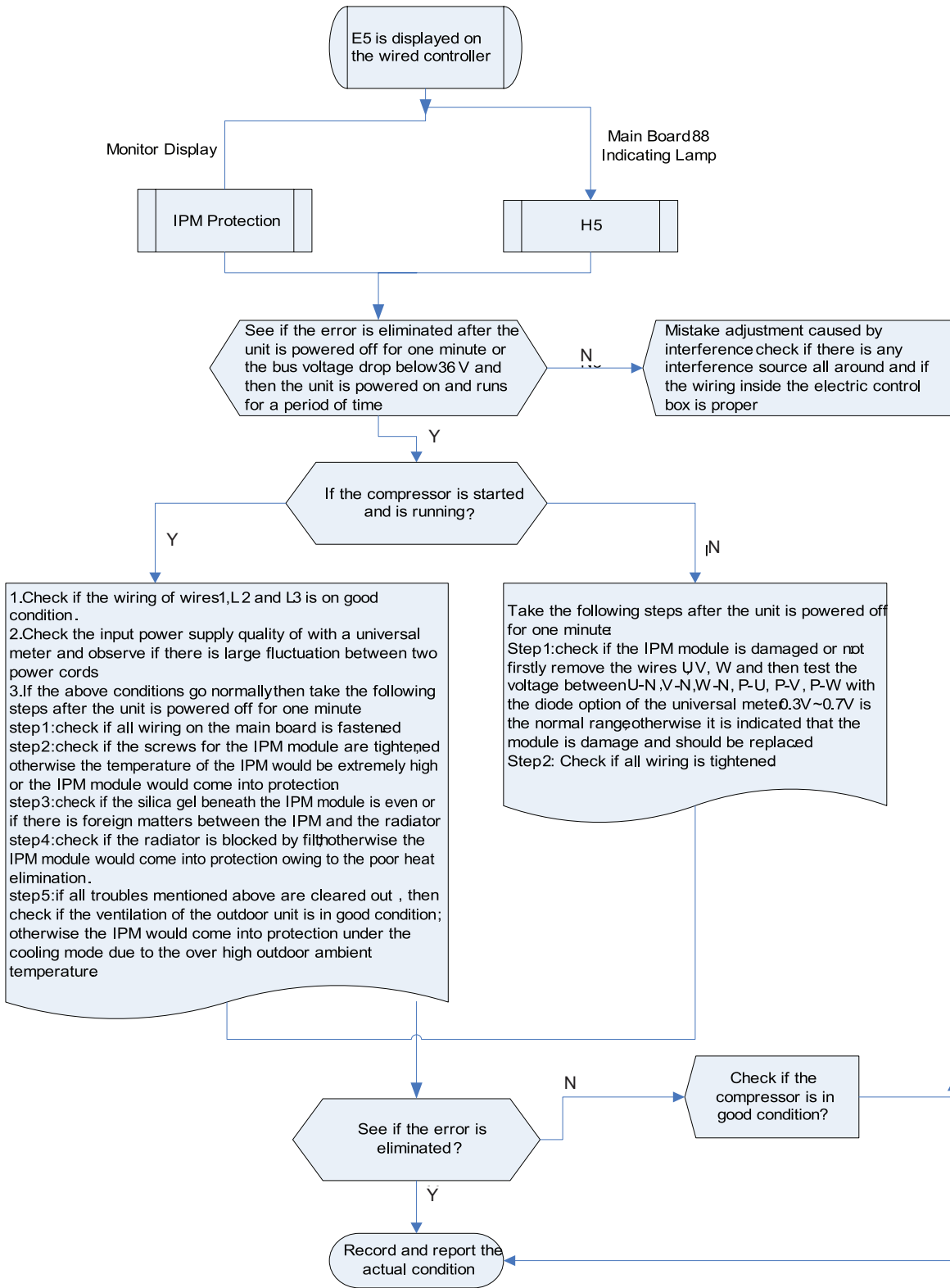

Method of Testing IPM Module Short Circuit:

1. Preparation before test: prepare a universal meter and turn to its diode option, and then remove the wires U, V, W of the compressor after it is powered off for one minute.

2. Testing Steps

Step 1: put the black probe on the place P and the red one on the wiring terminal U, V, W respectively as shown in the following figure to measure the voltage between UP, VP and WP.

Step 2: put the red probe on the place N and the black one on the wiring terminal U, V, W respectively as shown in the following figure to measure the voltage between NU, NV and NW.

3. If the measured voltages between UP, VP, WP, NU, NV, NV are all among 0.3V-0.7V, then it indicates the IPM module is normal; If any measured value is 0, it indicates the IMP is damaged.

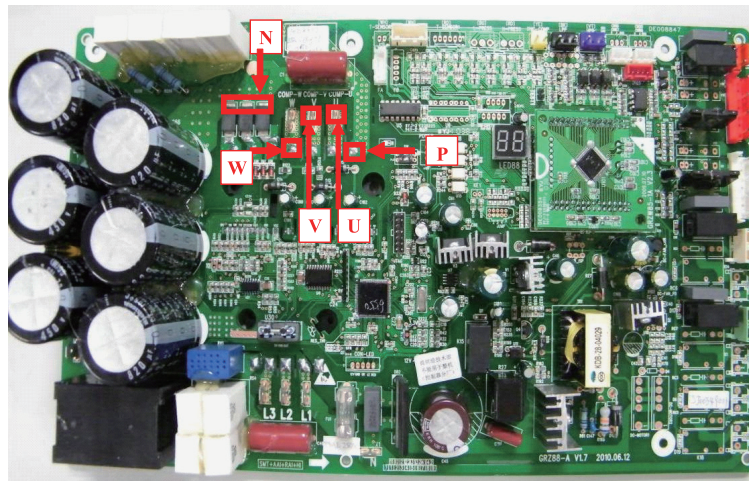

• PFC or IPM module overheat

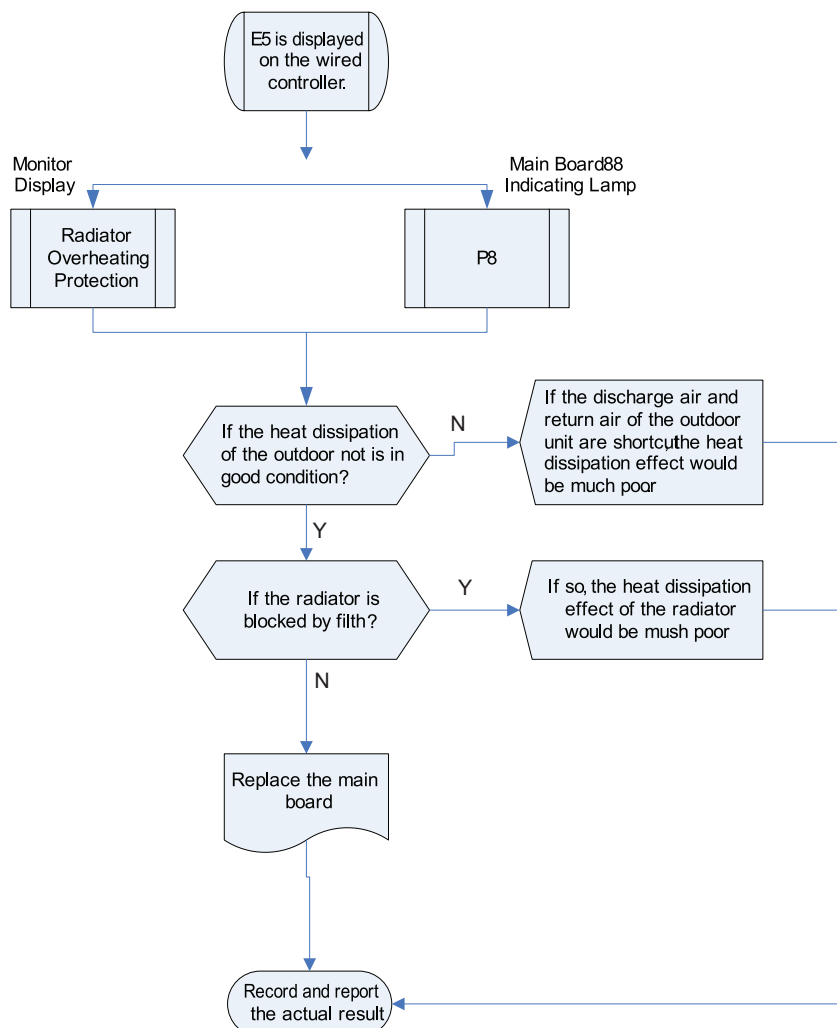

• Tripping

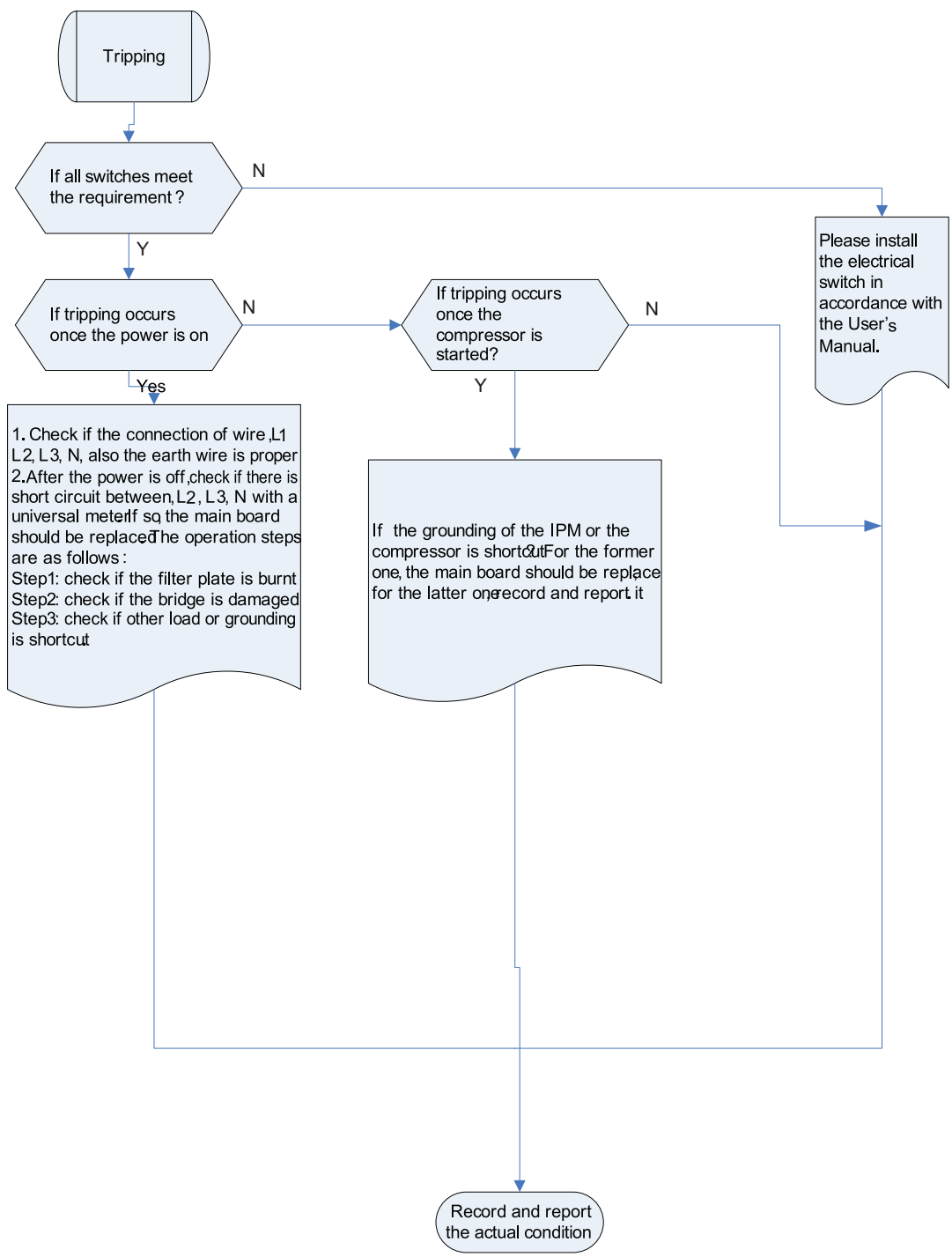

• DC Busbar underVoltage Protection

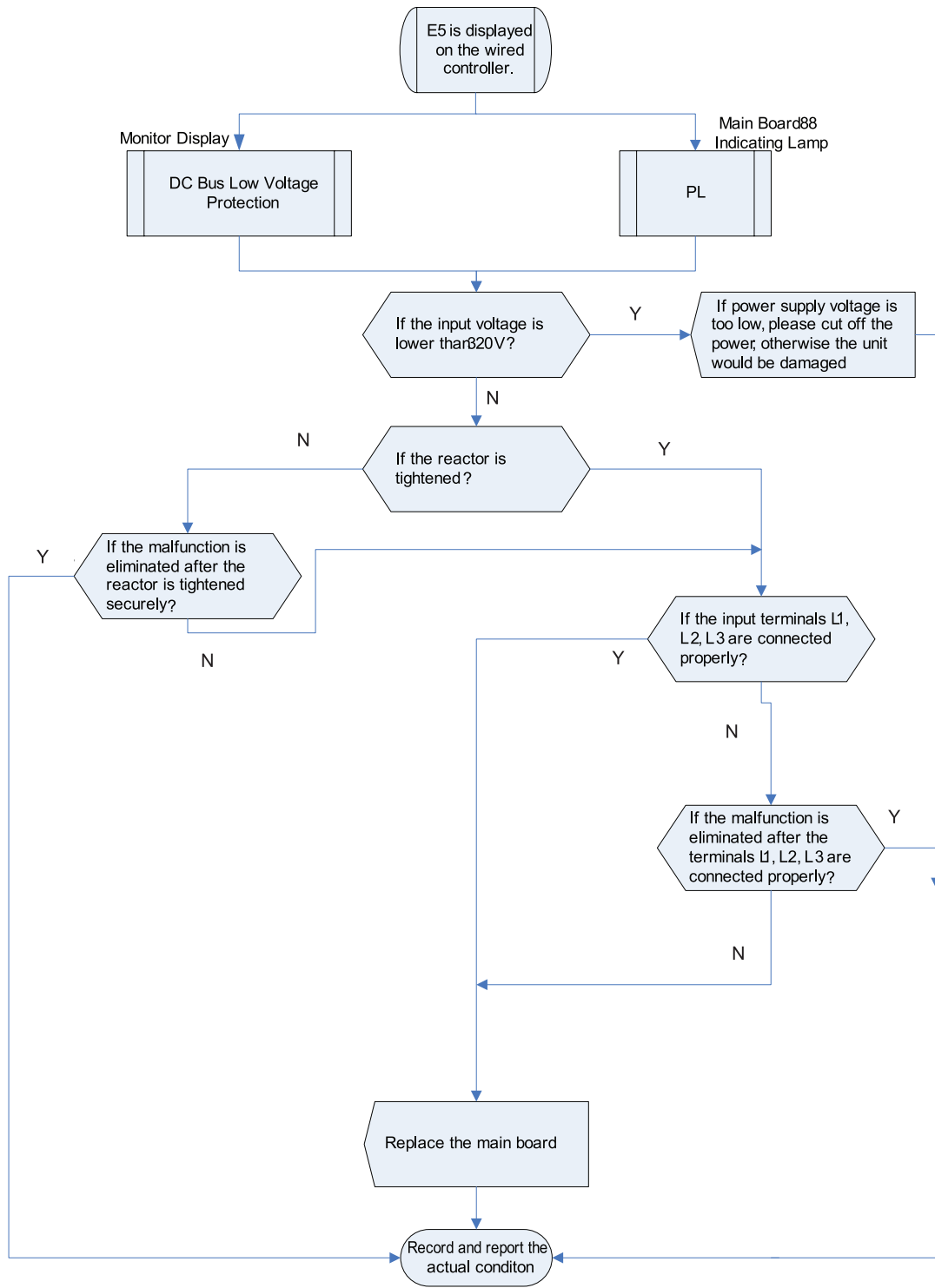

- DC busbar high voltage protection

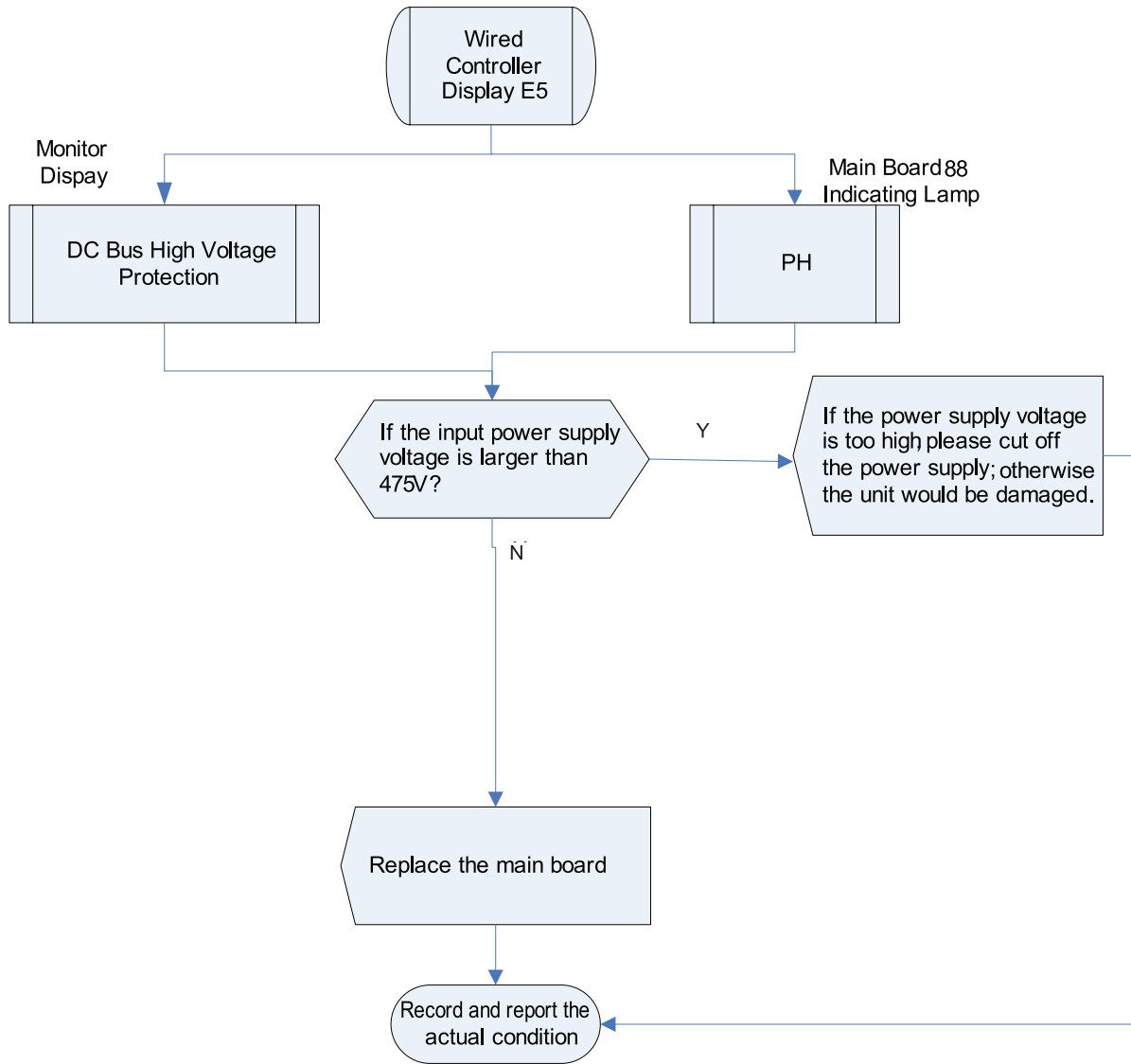

• Open Phase

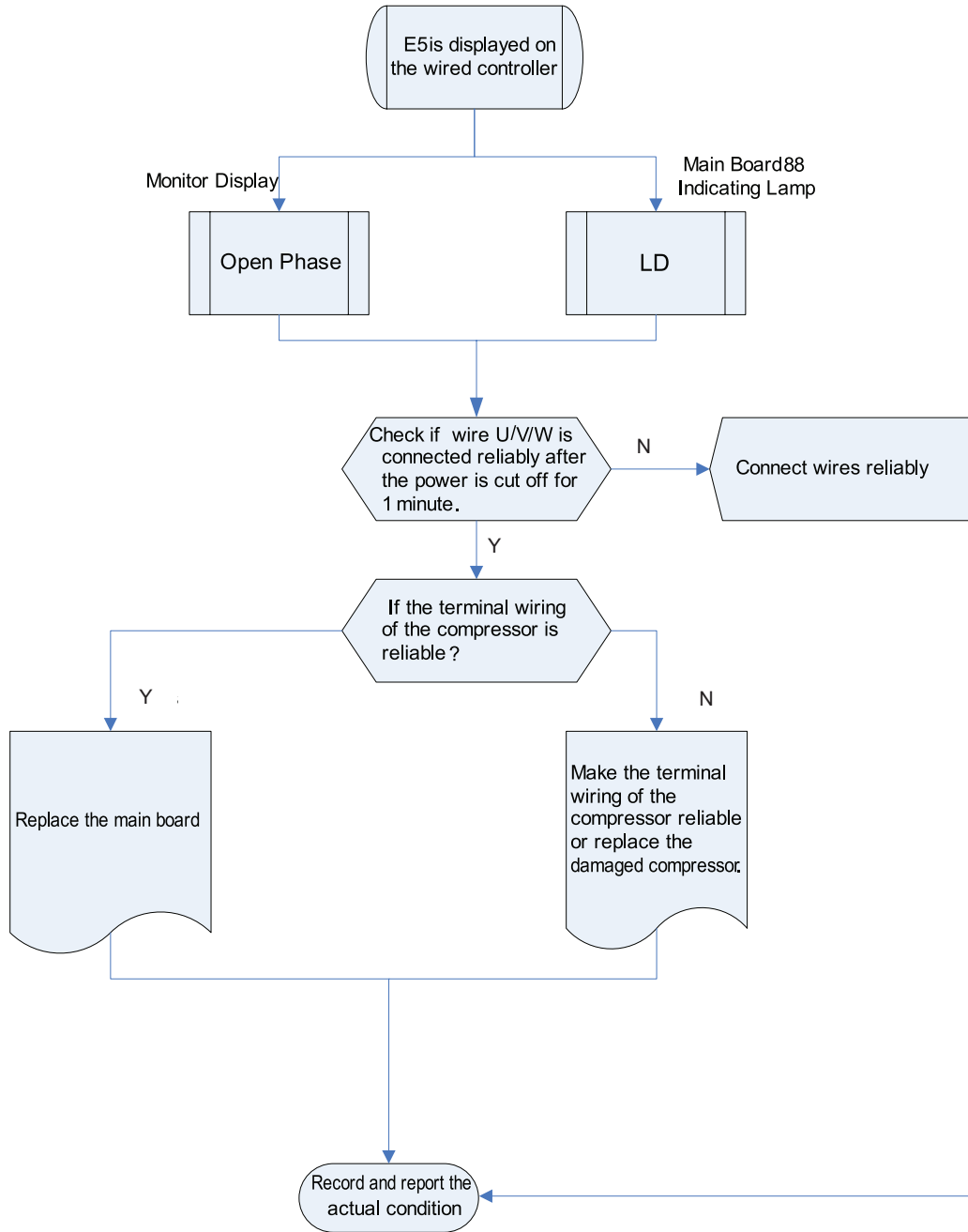

• Communication Error between the Indoor and Outdoor Units

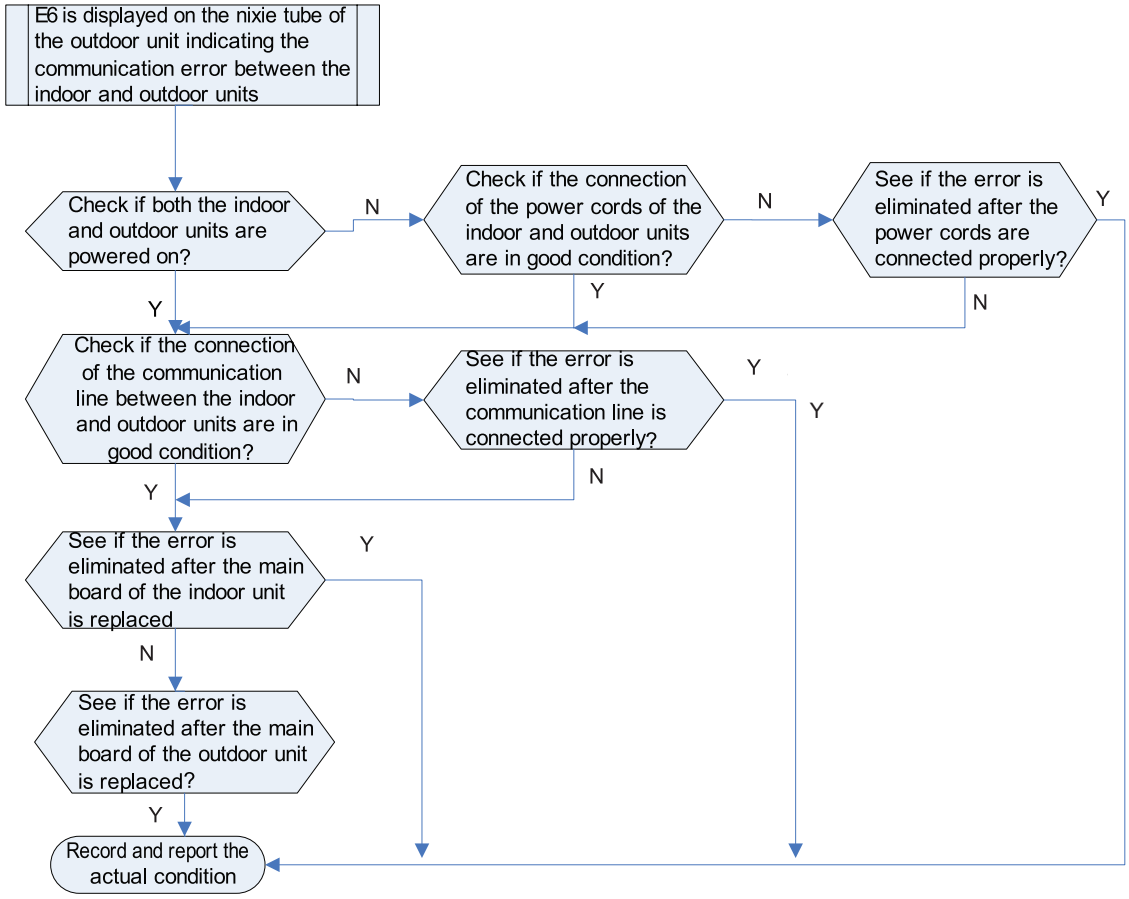

3 WIRING DIADRAM

3.1 Outdoor unit

The actual wiring should always refer to the wiring diagram of the unit.
Model: GUHD09NK3CO/ GUHD12NK3CO

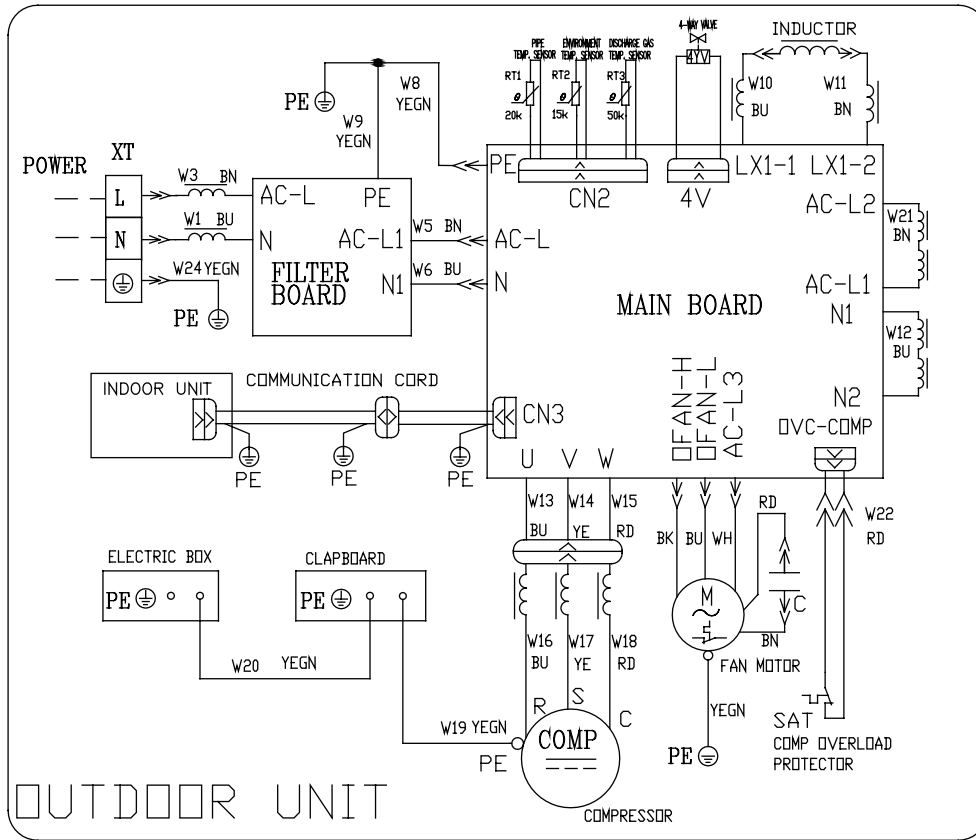

Model: GUHD18NK3CO

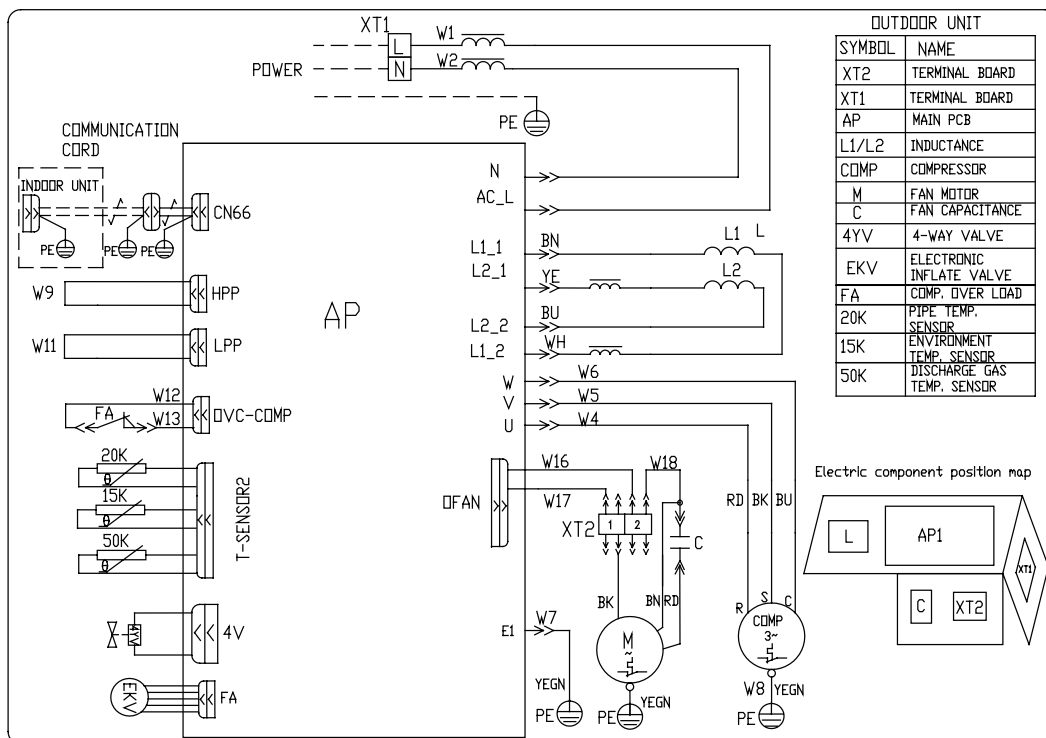

Model: GUHD09NK3C0/ GUHD12NK3C10

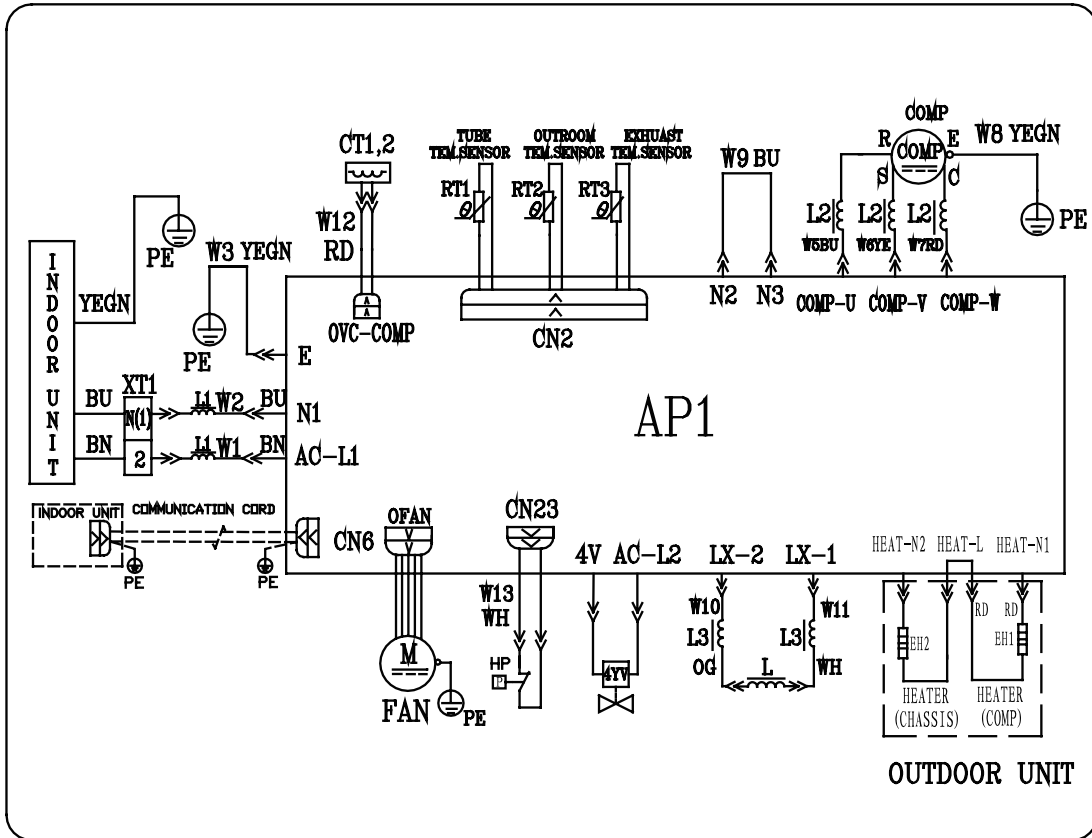

Model: GUHD18NK3C10

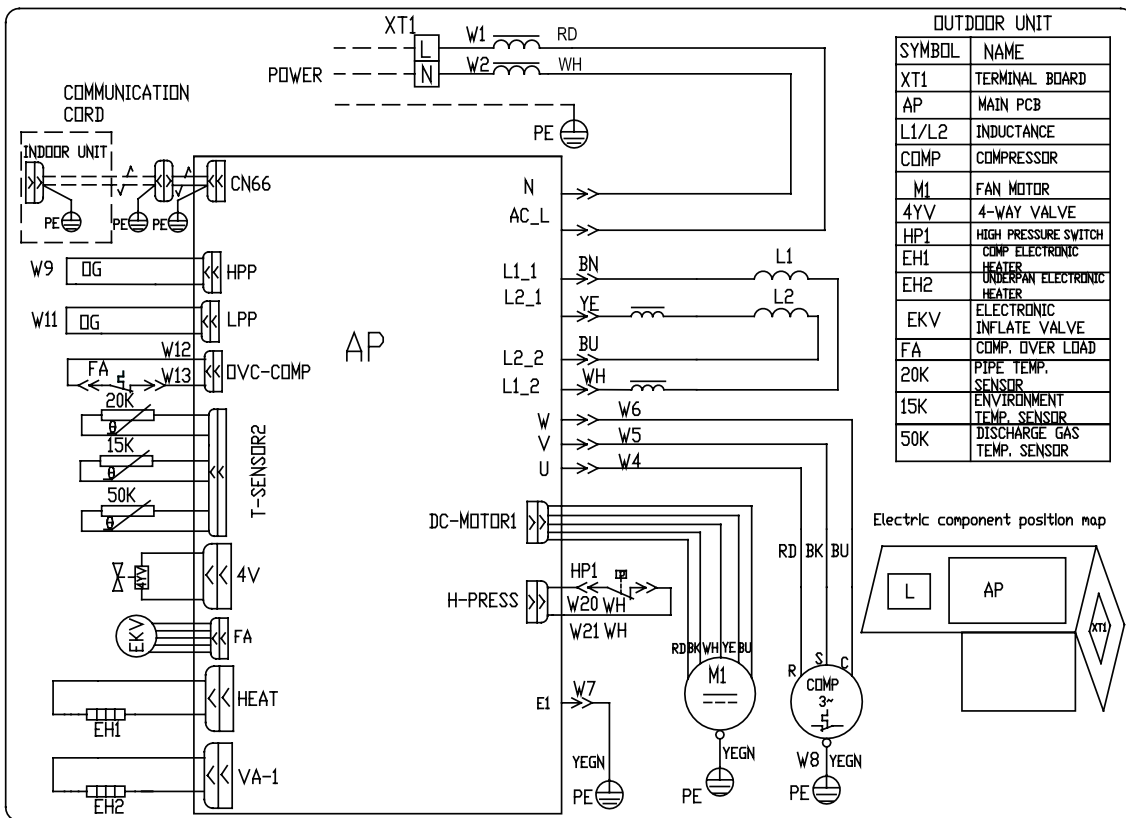

Model:GUHD24NK3C10/ GUHD30NK3C10

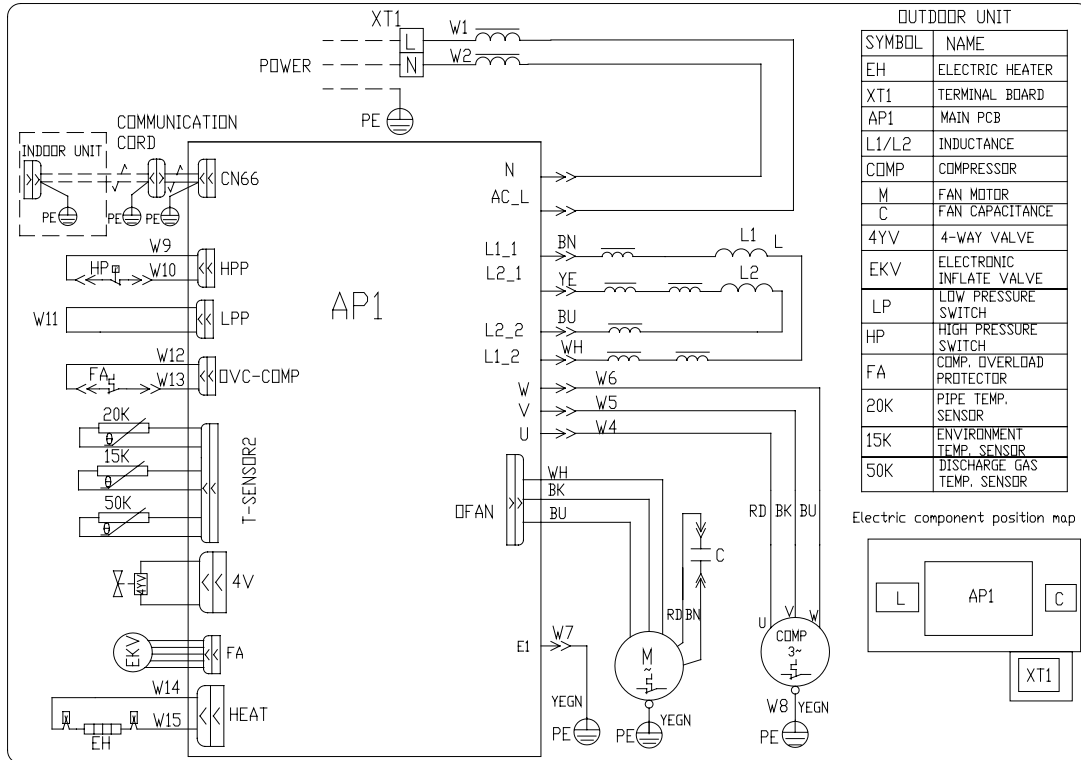

Model:GUHD36NK3CO/ GUHD42NK3CO

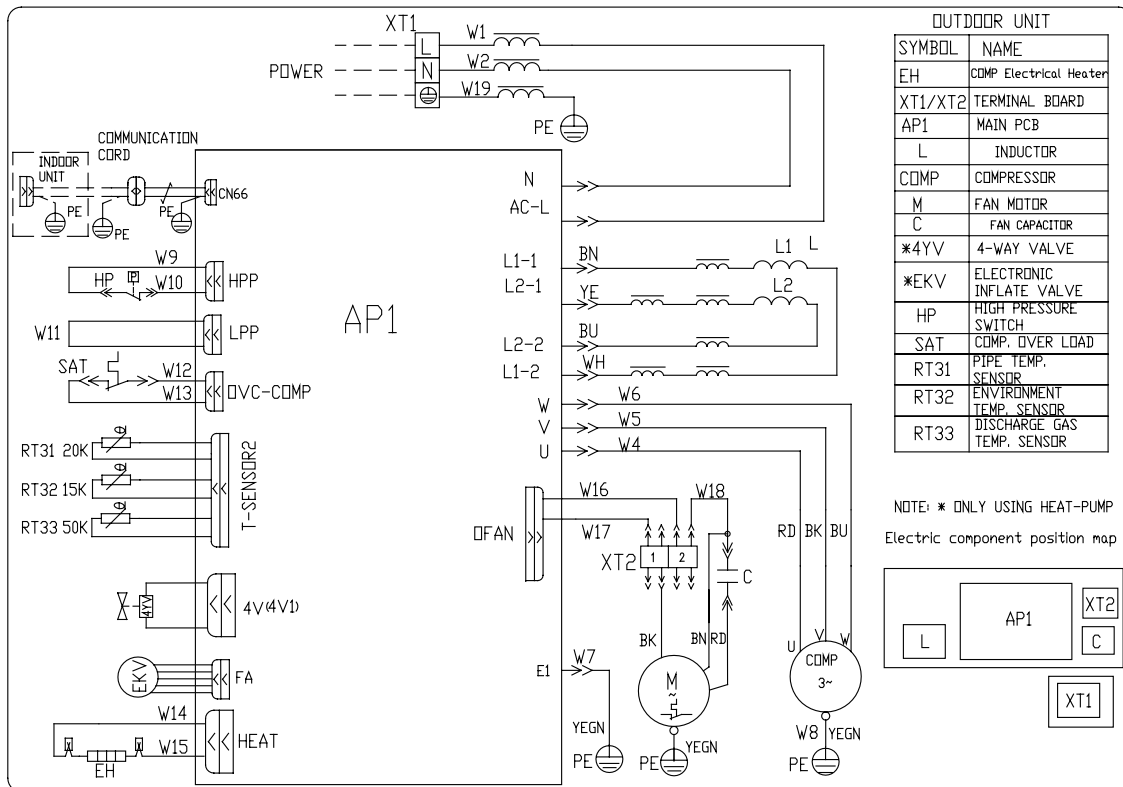

Model:GUHD24NK3C10/ GUHD30NK3C10

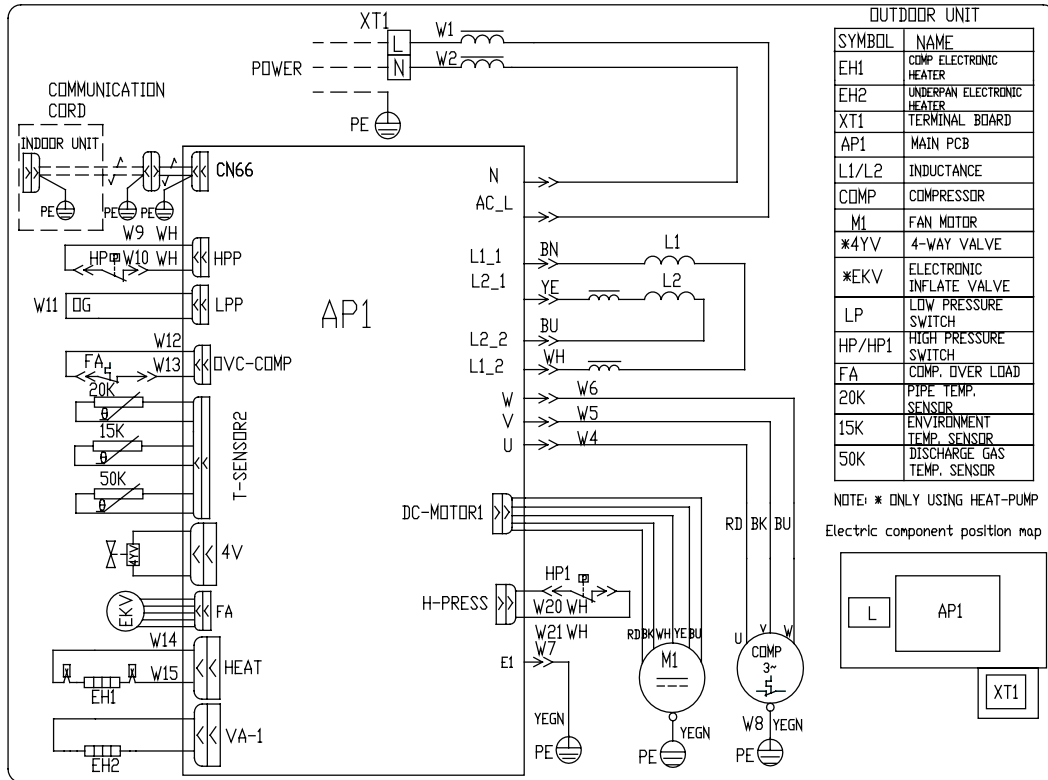

Model:GUHD36NK3C10/ GUHD42NK3C10

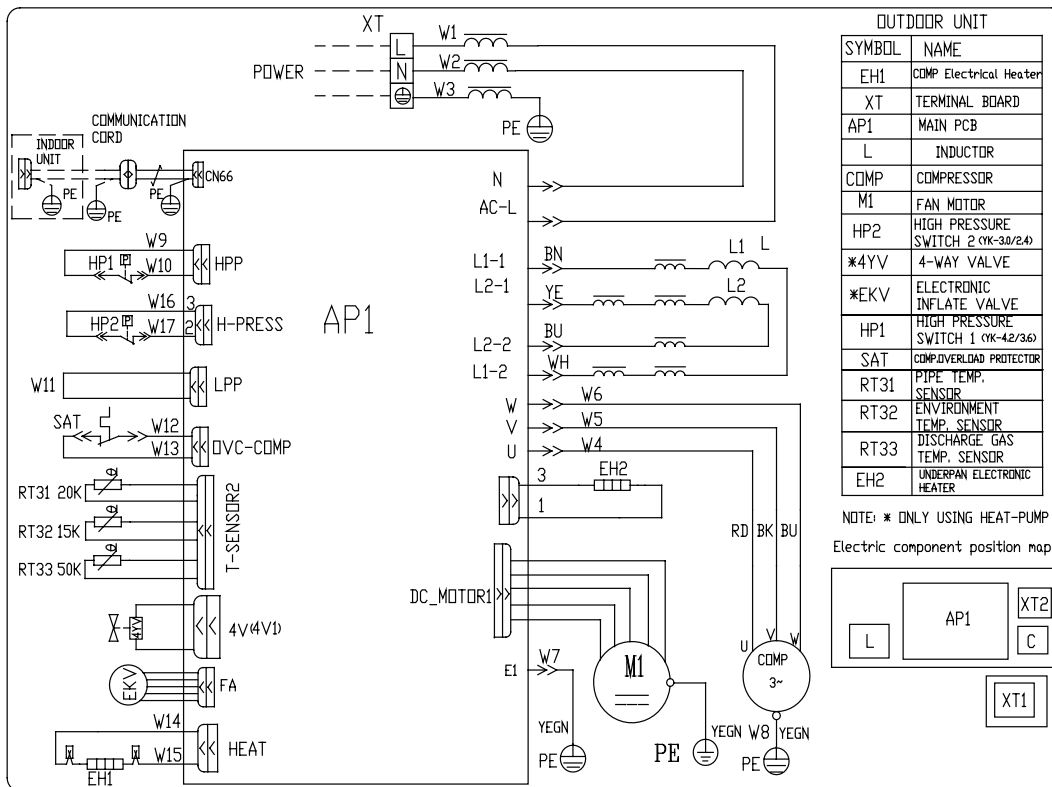

Model:GUHD48NK3CO

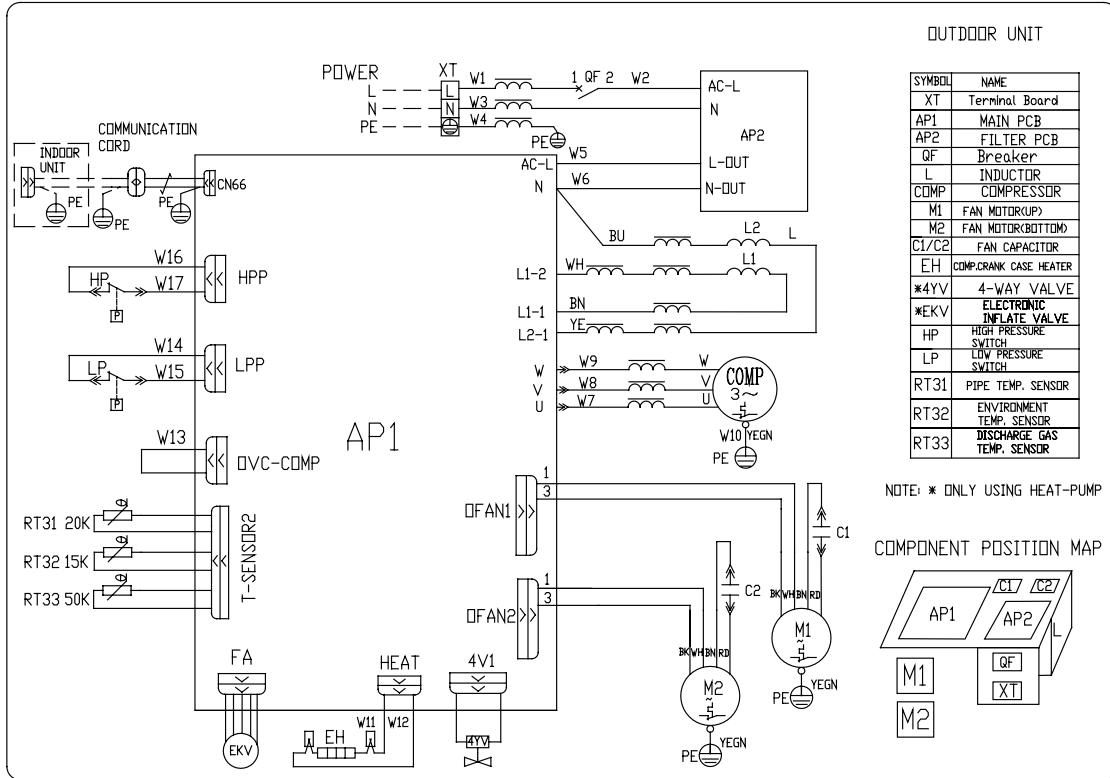

Model:GUHD36NM3CO/GUHD42NM3CO

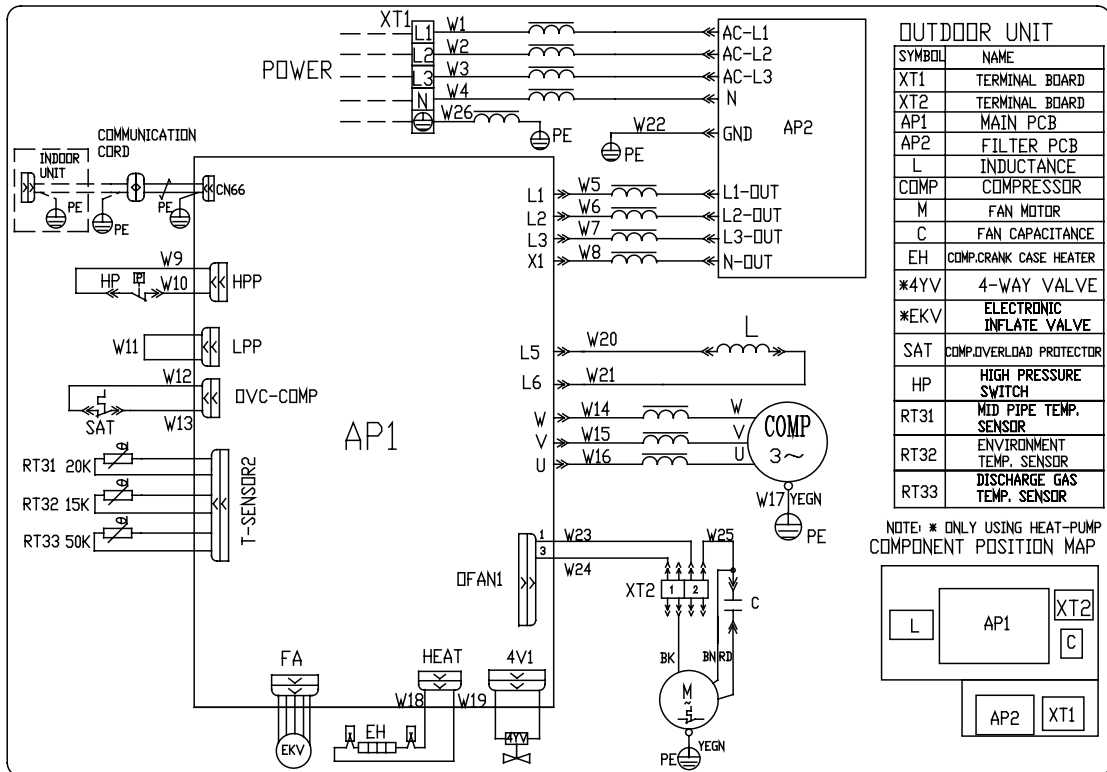

Model:GUHD48NK3C10

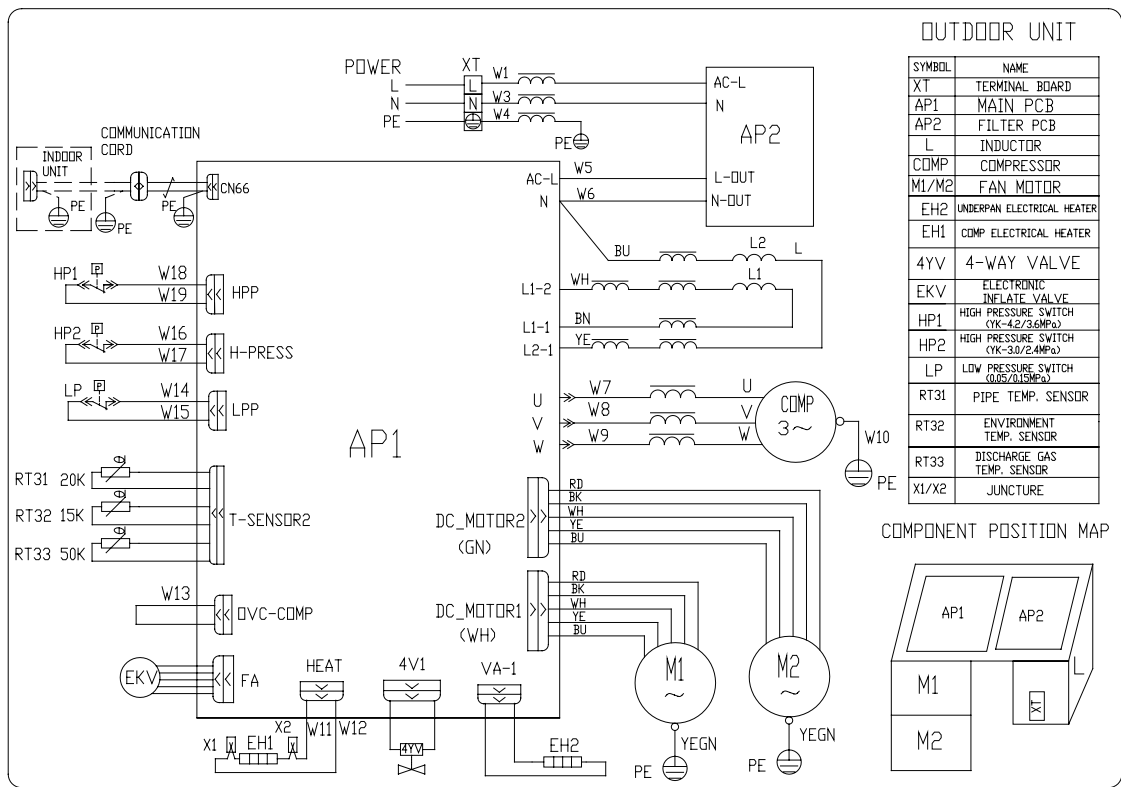

Model:GUHD36NM3C10/ GUHD42NM3C10

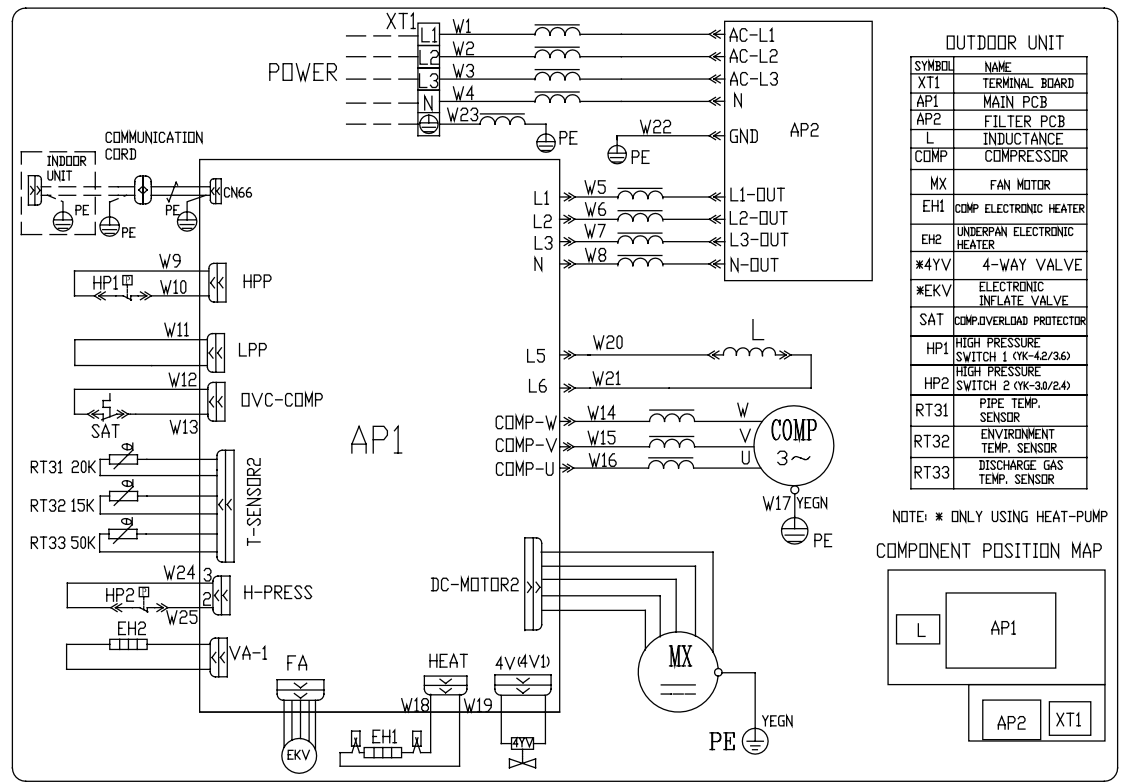

Model:GUHD48NM3CO

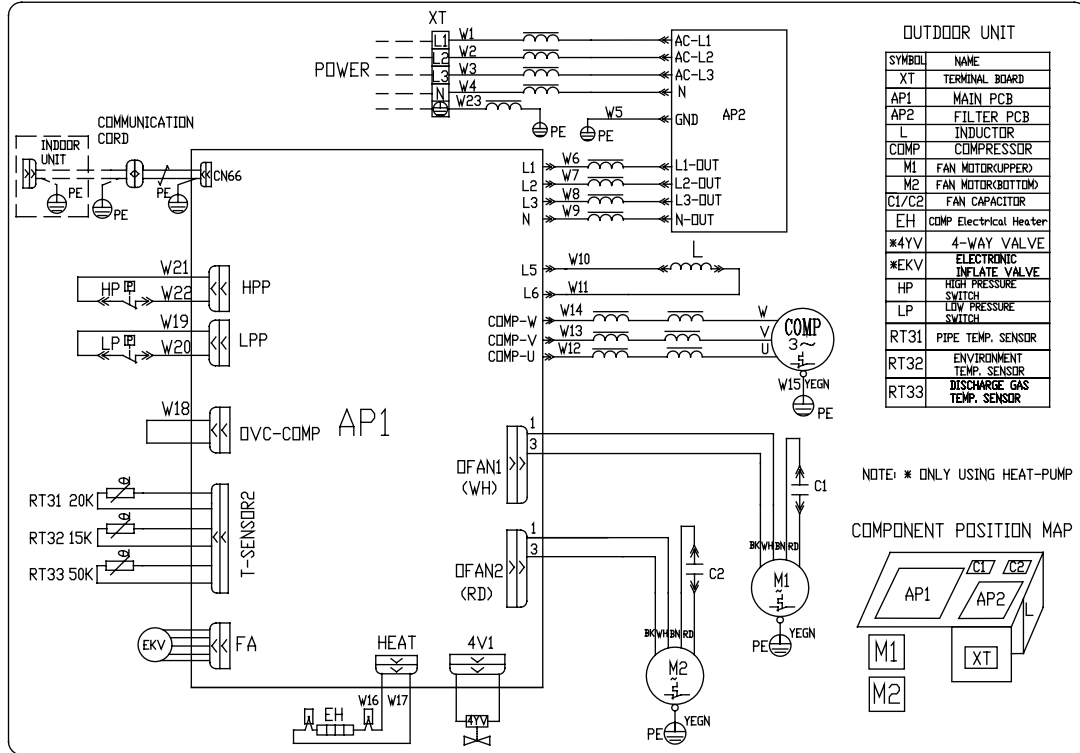

Model:GUHD60NM3CO

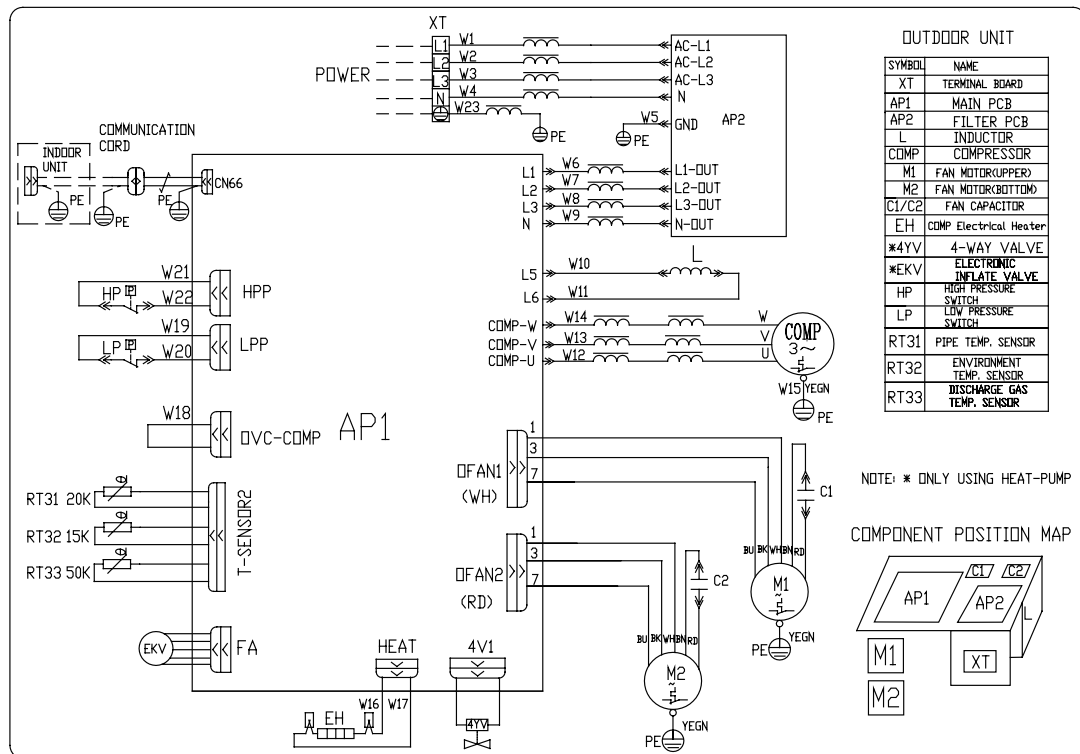

Model:GUHD48NM3C1O/ GUHD60NM3CO

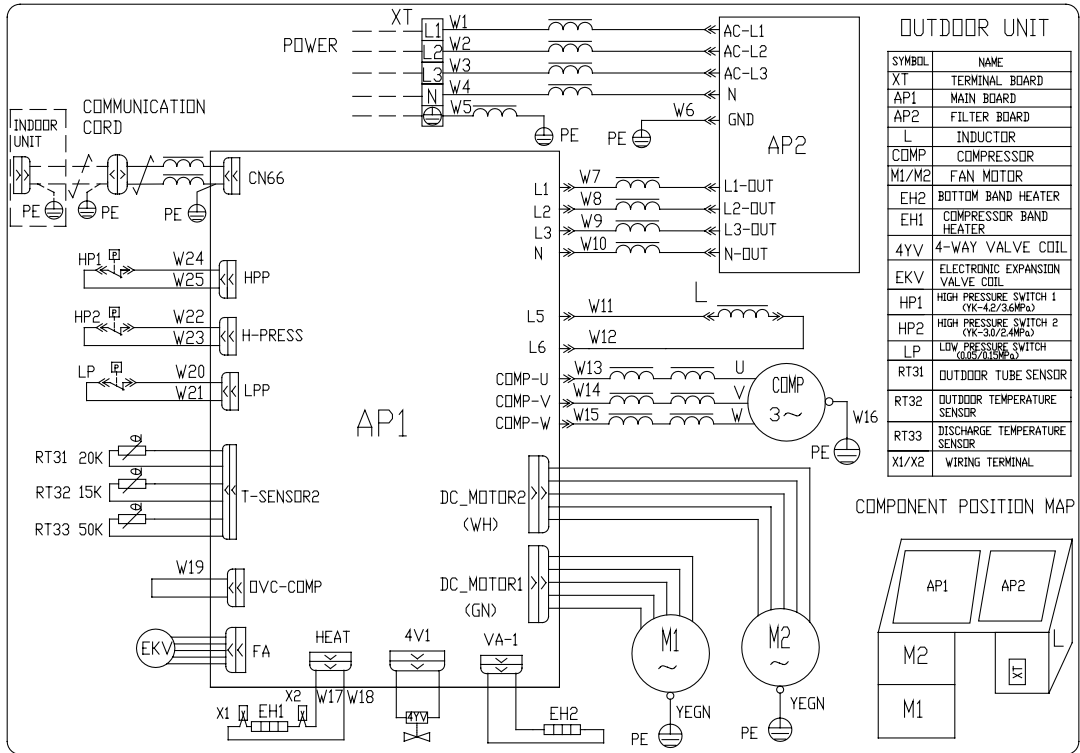

3.2 Indoor unit

The actual wiring should always refer to the wiring diagram of the unit.

Duct Type

Model:GFH09K3CI/GFH12K3CI/GFH18K3CI/GFH24K3CI/GFH30K3CI/GFH36K3CI/ GFH42K3CI/ GFH48K3CI/ GFH60K3CI

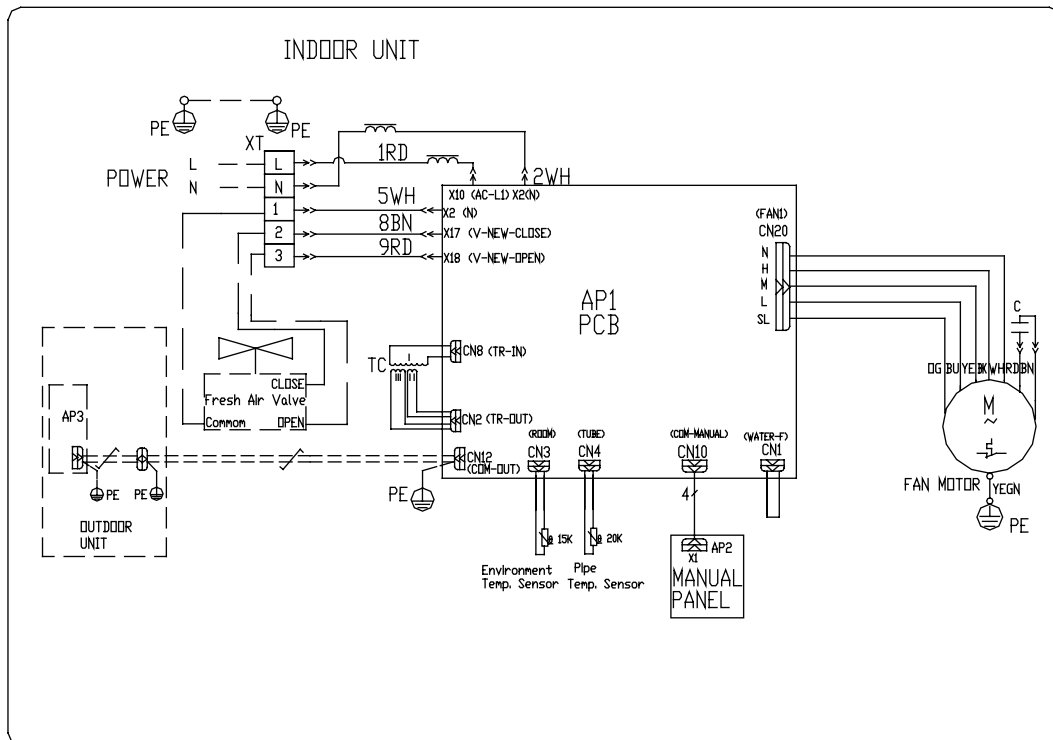

Floor Ceiling Type

Model:GTH09K3CI/ GTH12K3CI/ GTH18K3CI /GTH24K3CI

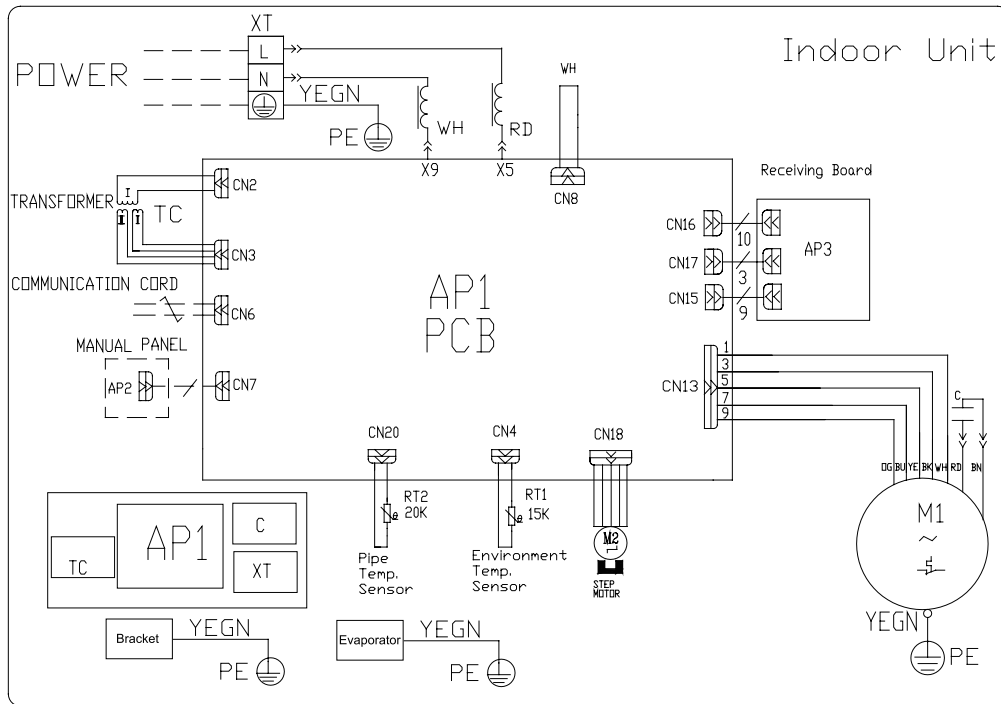

Model:GTH30K3CI/ GTH36K3CI/ GTH42K3CI

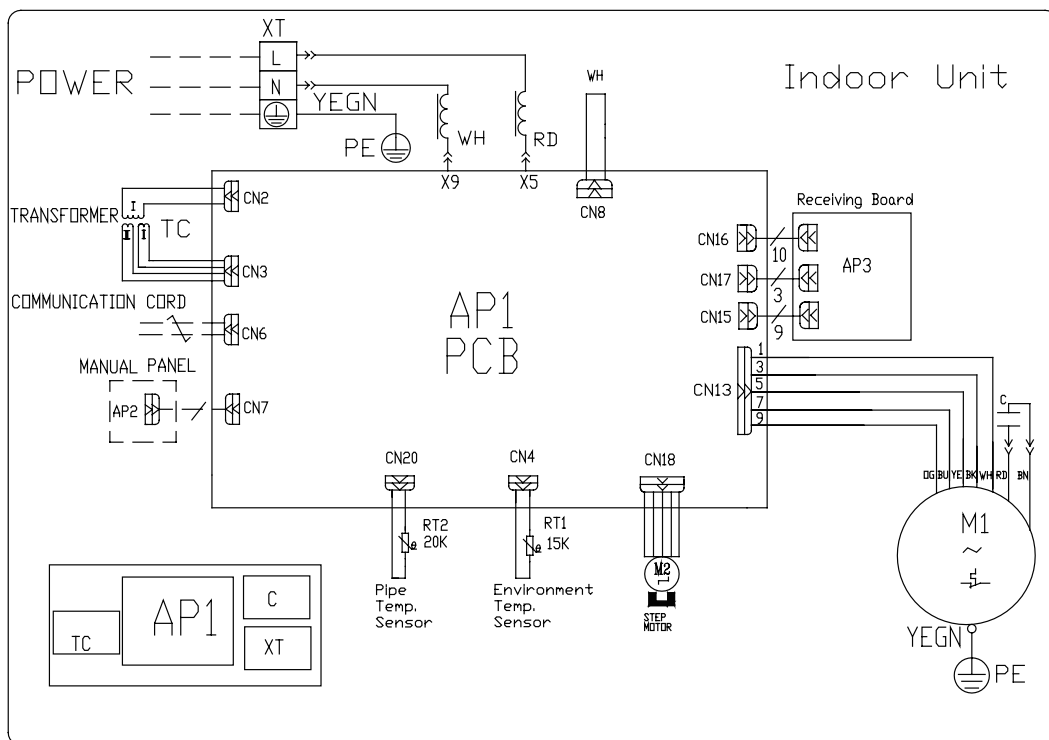

Model:GTH48K3CI/ GTH60K3CI

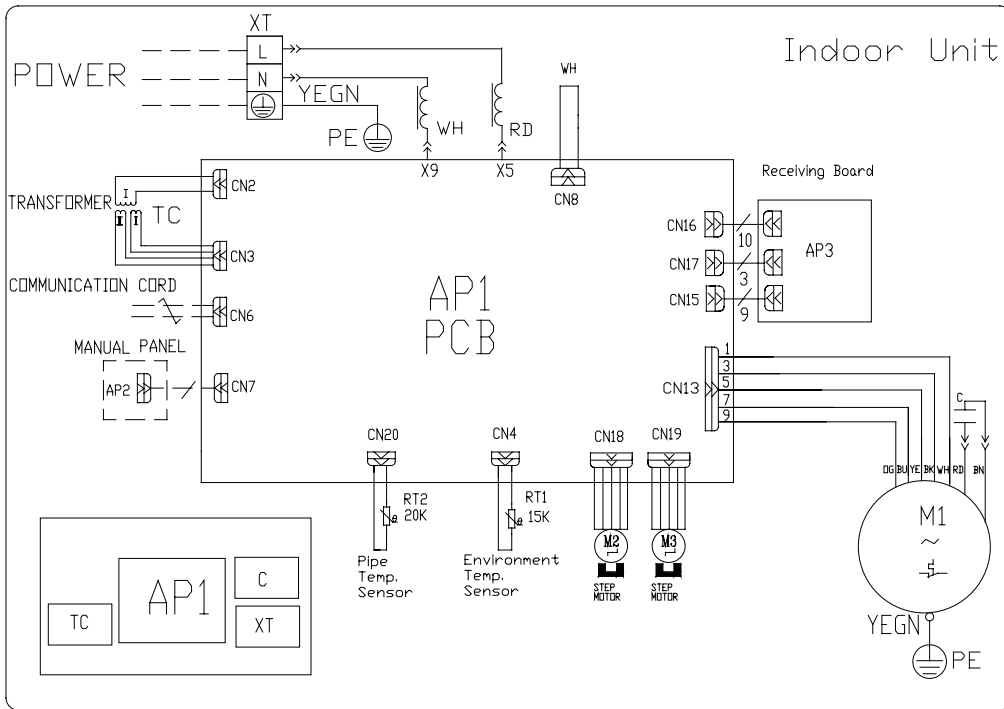

Casstee Type

Model:GKH12K3CI

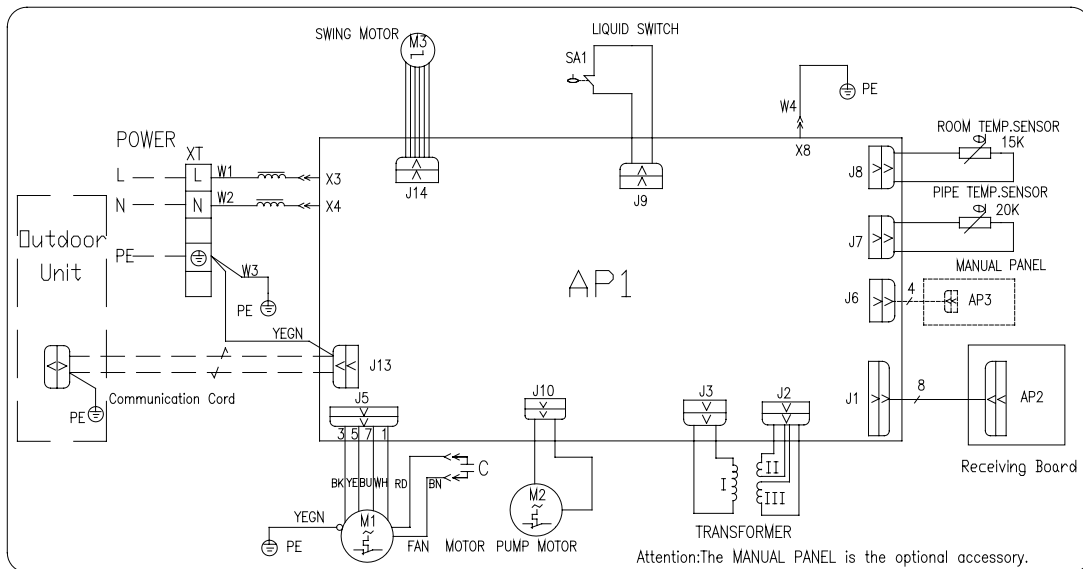

Model:GKH24K3CI

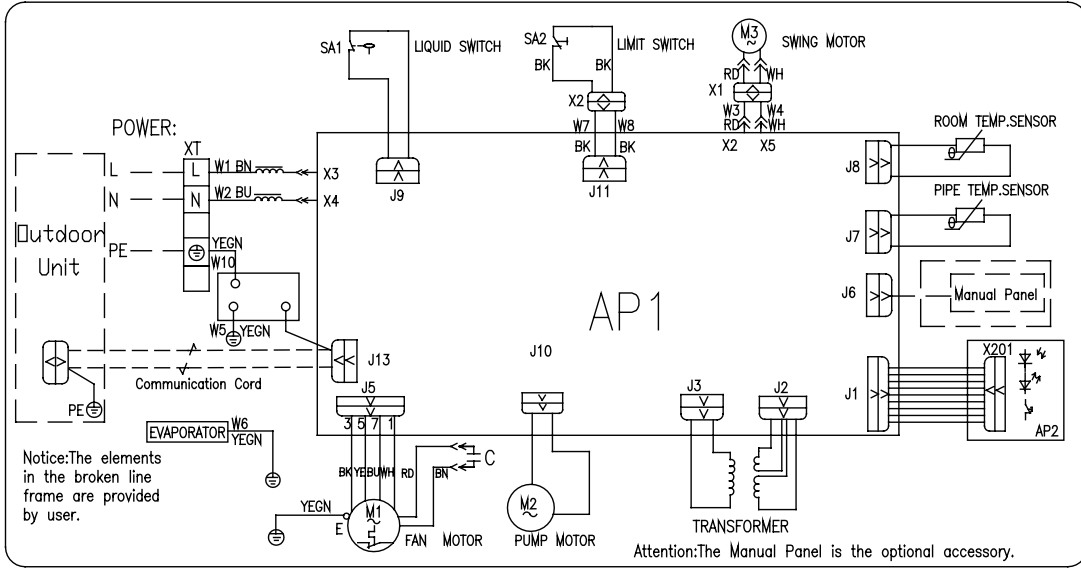

Model:GKH18K3CI/GKH30K3CI/ GTH36K3CI/ GTH42K3CI

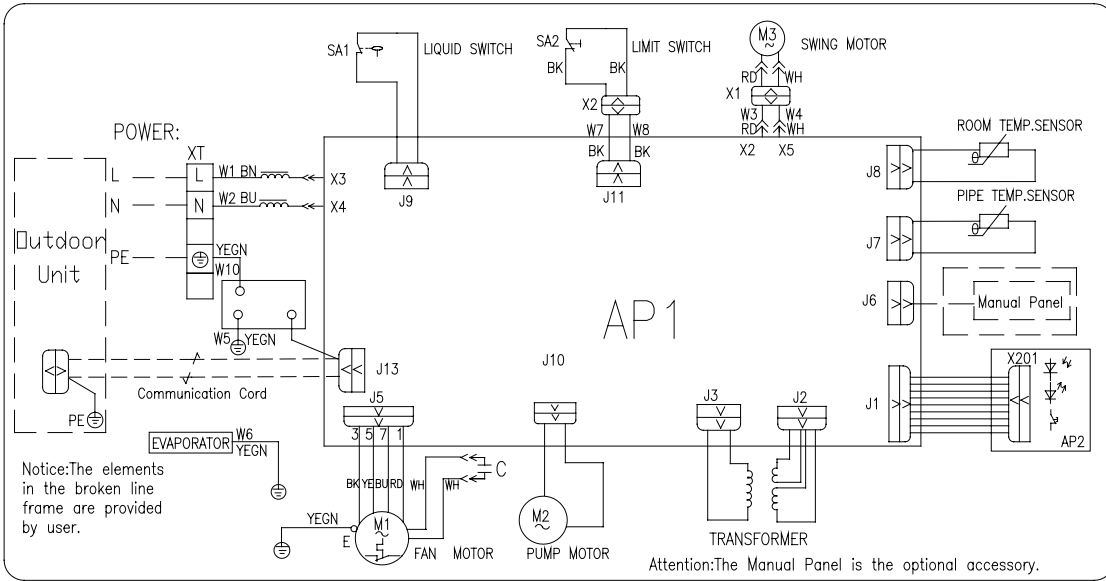

4 DISASSEMBLY AND ASSEMBLY PROCEDURE OF MAIN PARTS

4.1 Outdoor Unit

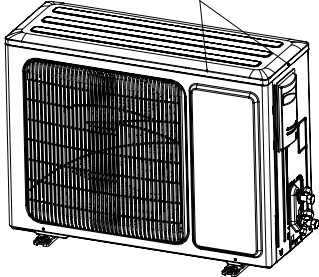
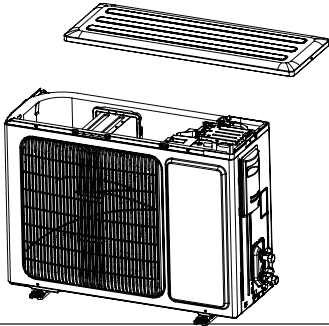
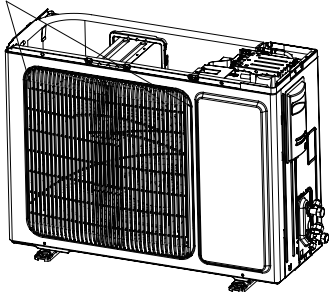
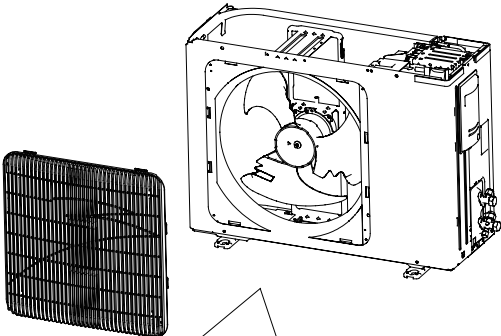
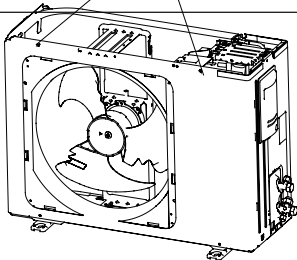
Double-fan Inverter Outdoor Unit, applicable to 9 KBtu/h~12 KBtu/h		
Disassembly and Assembly of external casing		
Note: Before removing the outer housing, make sure that the unit has been cut off from the power supply.		
Step	Illustration	Handling Instruction
1 Disassemble the top panel		a. Cut off the power supply b. Recover the refrigerant c. Loosen the screws on the top panel with a screw driver.
2 Remove the top panel		Remove upwards the top panel away from the unit.
3. Disassemble the grille		Loosen the screws on the grille with a screw driver.
4.Remove the grille		Remove the grille away from the unit .
5. Disassemble the back panel		Loosen the screws between the front panel and the partition board with a screw driver.

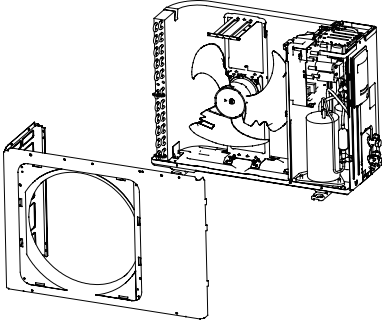
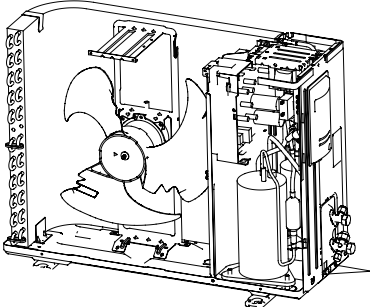
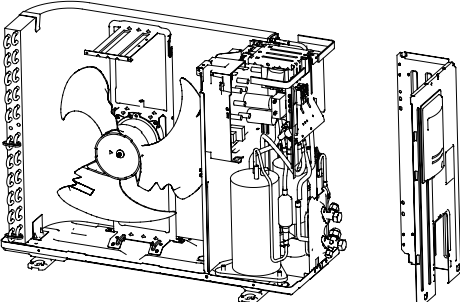
<p>6. Remove the back panel.</p>		<p>Remove the back panel away from the unit .</p>
<p>7. Disassemble the right side panel.</p>		<p>Loosen the screws on the side panel with a screw drive.</p>
<p>8. Remove the right side panel.</p>		<p>Remove the right side panel away from the unit.</p>

Removal and Installation of Gas-liquid Separator and Compressor

Remark: Before removing the compressor, make sure that there is no refrigerant inside the pipe system and that the power has been cut off.

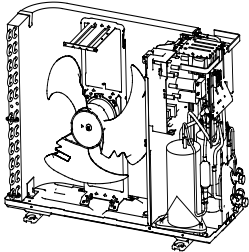
Step	Illustration	Handling Instruction
<p>1. Disconnect the wiring of the power supply of the compressor</p>		<p>a. Open the cover of the power supply box with a wrench. b. Disconnect the power cord of the compressor with the pliers. c. Pull out the power supply plug of the compressor.</p>
<p>2. Loosen the screws on the compressor</p>		<p>Loosen the screws between the compressor and the compressor base with a wrench.</p>

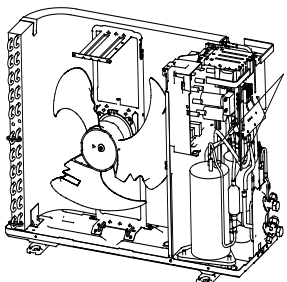
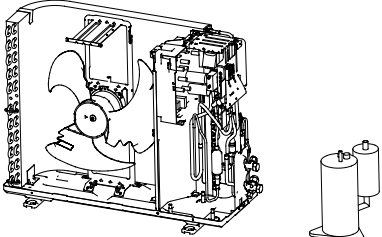
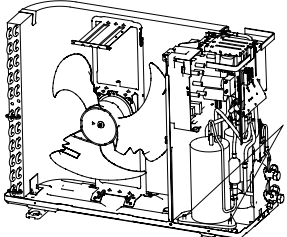
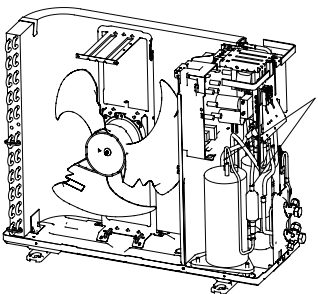
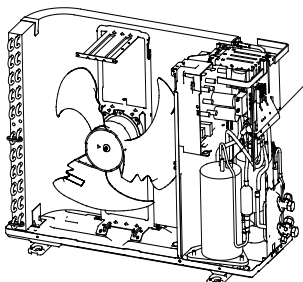
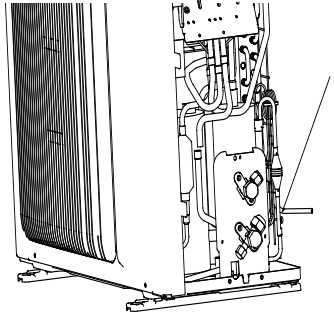
<p>3. Disconnect the suction and discharge pipes of the compressor</p>		<p>a. Dismantle the gas-liquid separator through heating its inlet/outlet pipe by the means of gas welding. b. During the welding, nitrogen should be inflated and its pressure should be $0.5 \pm 0.1 \text{ kgf/cm}^3$ (relative pressure) c. Attention should be taken during the heating to avoid the surrounding objects burnt due to the high temperature.</p>
<p>4. Remove the compressor away</p>		<p>Remove the compressor away from its base.</p>
<p>5. Place the new compressor on the base</p>		<p>a. Put the new compressor in the right place. b. Tighten the screws of the compressor with a wrench c. Never put the compress upside down</p>
<p>6. Connect the suction/discharge pipes of the compressor with the system piping.</p>		<p>a. Connect the suction/discharge pipes of the compressor by means of gas welding. b. During the welding, nitrogen should be inflated and its pressure should be $0.5 \pm 0.1 \text{ kgf/cm}^3$ (relative pressure) c. Attention should be taken during the heating to avoid the surrounding objects burnt due to the high temperature.</p>
<p>7. Connect the power cord of the compressor</p>		<p>a. Connect the power cord as the reverse way of disconnection mentioned above. b. Tighten the cover of the compressor with a screw driver.</p>
<p>8. Establish vacuum through liquid valve</p>		<p>Establish vacuum inside the system through liquid valve.</p>

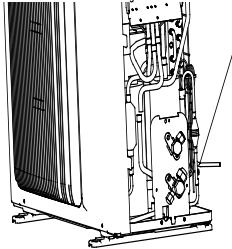
<p>9. Charge refrigerant through liquid valve</p>		<p>Recharge the refrigerant to the system through liquid valve.</p> <p>The charge volume must be identical to the indications on nameplate.</p>
---	---	---

Disassembly and Assembly of 4-way valve
 Note: Before removing the 4-way valve, make sure that there is no refrigerant inside the pipe system and that the power has been cut off.

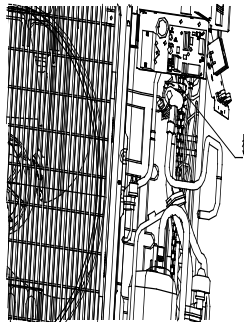
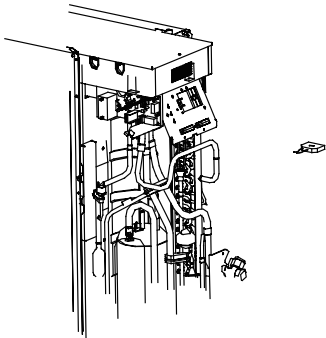
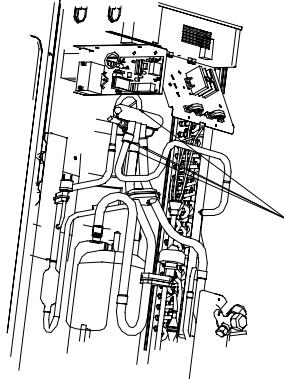
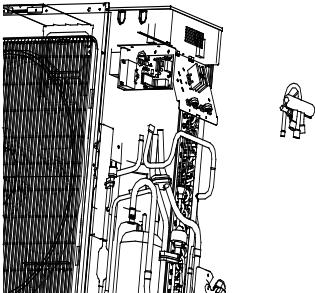
Step	Illustration	Handling Instruction
<p>1. Loosen the solenoid valve</p>		<p>a. Cut off the power supply b. Recover the refrigerant. c. Loosen the bolts on the solenoid valve with a wrench.</p>
<p>2. Remove the solenoid valve</p>		<p>Remove the solenoid away from the four-way valve.</p>
<p>3. Remove the 4-way valve</p>		<ul style="list-style-type: none"> ● Use gas welding to heat the pipes connected on the four openings of 4-way valve. Then, pull them out from 4-way valve. ● Before welding 4-way valve, please record the orientation of 4-way valve and installing position of each opening.
<p>4. Remove 4-way valve</p>		<ul style="list-style-type: none"> ● Remove the old 4-way valve from the unit.

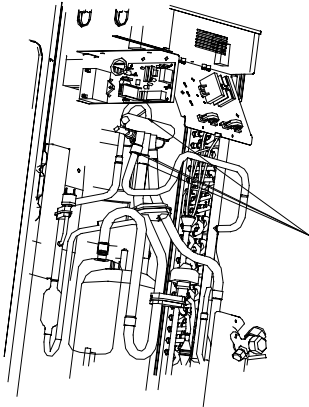
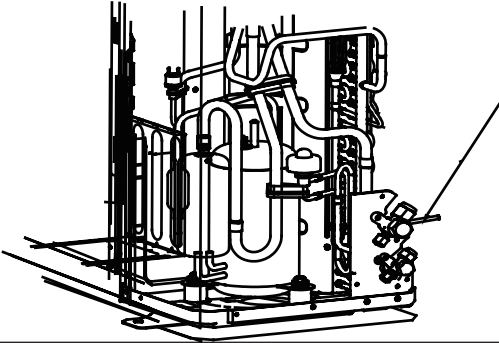
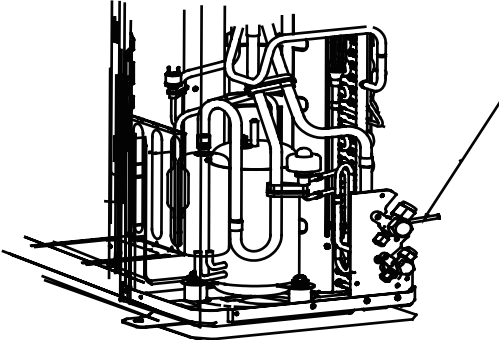
<p>5. Connect the new 4-way valve to the pipe.</p>		<ul style="list-style-type: none"> ● Install the new 4-way valve to correct position. ● When welding the 4-way valve, please wrap the valve body with wet cloth, thus to prevent the guide inside the valve body from burn. Also take care to prevent any water from flowing into the pipe. ● Weld by charging nitrogen, with the nitrogen pressure kept at $0.5 \pm 0.1 \text{ kgf/c}$ (relative pressure).
<p>6. Establish vacuum inside the system through liquid valve.</p>		<ul style="list-style-type: none"> ● Establish vacuum inside the system through liquid valve.
<p>7 Recharge the refrigerant to the system through liquid valve.</p>		<ul style="list-style-type: none"> ● Recharge the refrigerant to the system through liquid valve. ● The charge volume must be identical to the indications on nameplate.

Removal and Installation of Fan and Motor

Note : Before the dismantlement of the motor, make sure the unit is powered off.

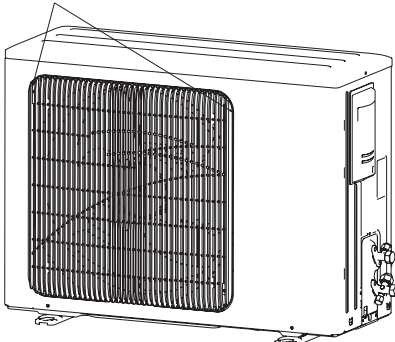
Step	Illustration	Handling Instruction
<p>1 Loosen the grille.</p>		<p>Loosen the screws between the grille and the back panel with a screw driver.</p>

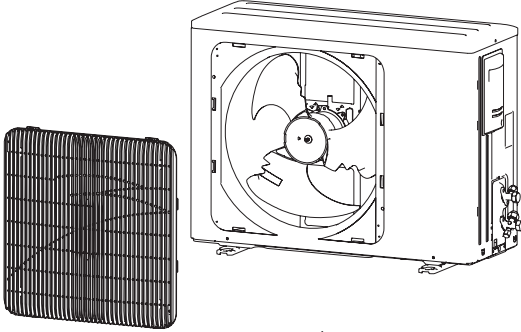
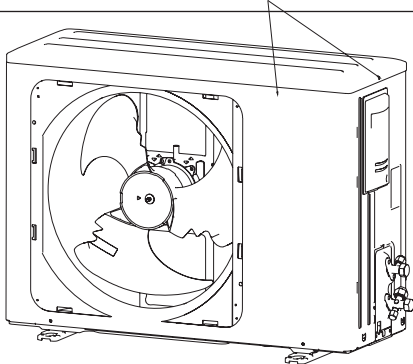
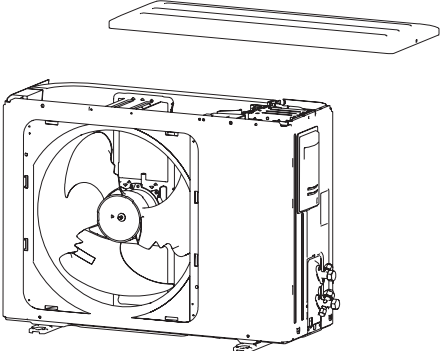
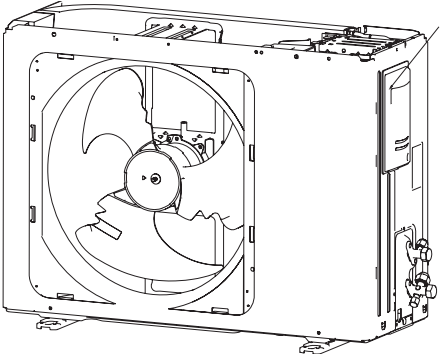
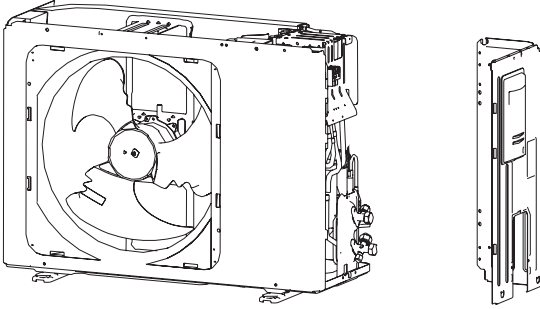
<p>2. Remove the grille</p>		<p>Remove the grill away from the back panel.</p>
<p>3. Loosen the top panel</p>		<p>Loosen the screws on the top panel with a screw driver.</p>
<p>4. Remove the electric box cover</p>		<ul style="list-style-type: none"> ●Use screwdriver to loosen the screws on electric box cover. ●Remove the cover from electric box.
<p>5. Loosen the backside panel</p>		<p>Loosen the screws on the backside panel with a screw driver.</p>
<p>6. Remove the rear side plate.</p>		<p>Remove the rear side plate away from the unit</p>

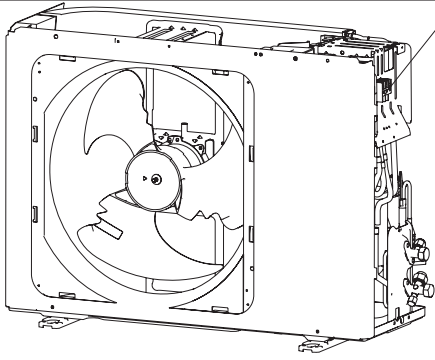
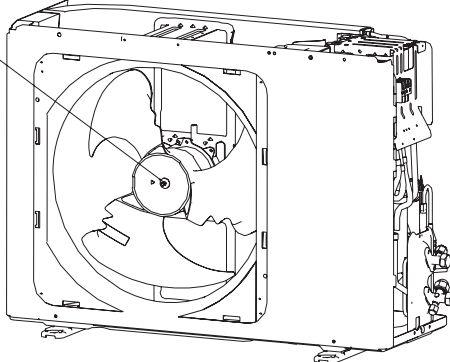
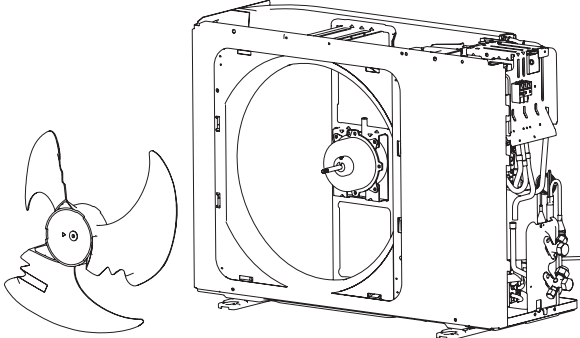
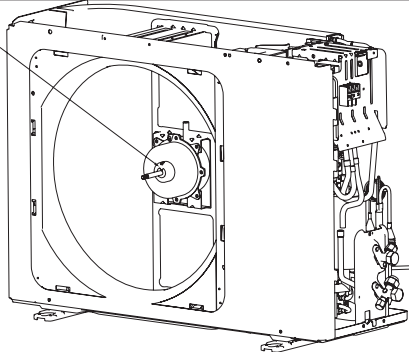
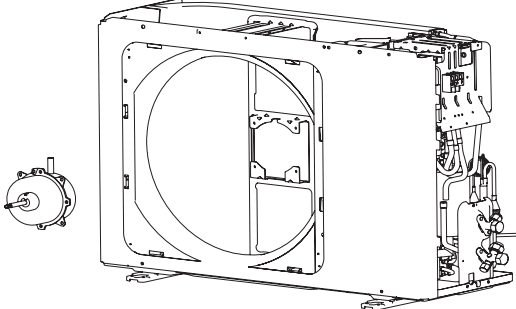
<p>7. Disconnect the power cord of the motor</p>		<p>Disconnect the motor power cord on the main board with hands or pliers</p>
<p>8 Remove the fan from motor</p>		<p>Remove the fan from motor.</p>
<p>9. Remove the fan blades</p>		<p>Remove the fan blades away from the motor.</p>
<p>10. Loosen the motor</p>		<p>Loosen the bolts on the motor with a wrench.</p>
<p>11. Remove the motor</p>		<ul style="list-style-type: none">●Use spanner and screwdriver to remove the bolts fixing the motor.●Remove the motor from motor support.

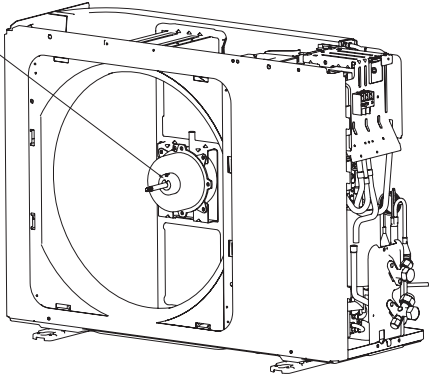
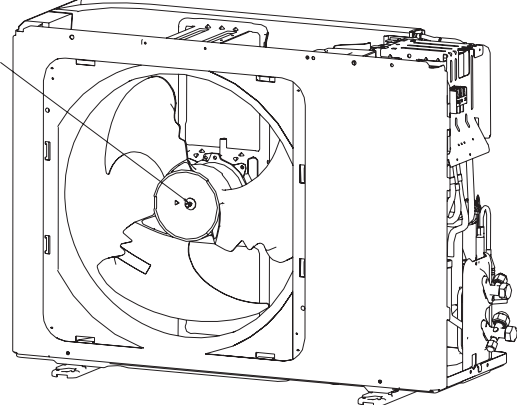
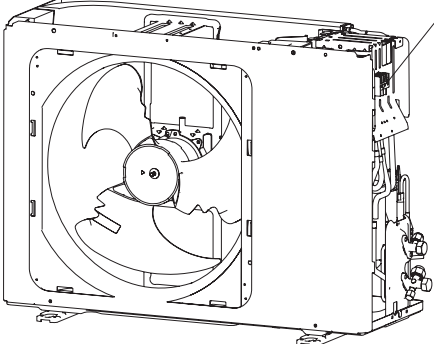
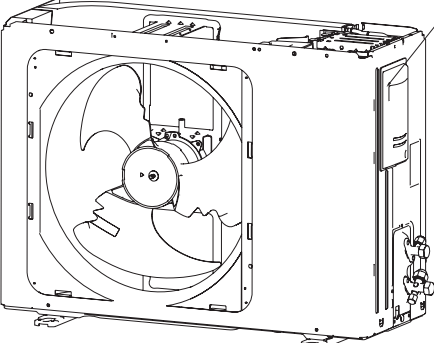
<p>12. Install a new motor to motor support</p>		<ul style="list-style-type: none"> ●Put the new motor to correct position. ●Use spanner and screwdriver to fix the motor to motor support with bolts.
<p>13. Assemble the fan</p>		<ul style="list-style-type: none"> ●Assemble the axial flow fan to correct position and fix it to the motor shaft in reverse to the disassembly procedures. ●Put the electric box cover to correct position and fix it onto the electric box according to disassembly procedures.
<p>14. Connect the motor power cable</p>		<ul style="list-style-type: none"> ●Connect the insert of motor power cable to the mainboard terminal in reverse to the disassembly procedures.
<p>15. Assemble the electric box cover</p>		<ul style="list-style-type: none"> ●Assemble the electric box cover to correct position ● Use screwdriver to fix the cover onto electric box.

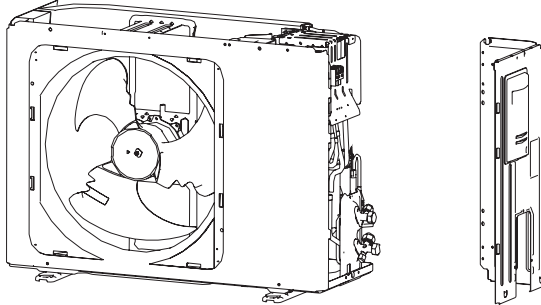
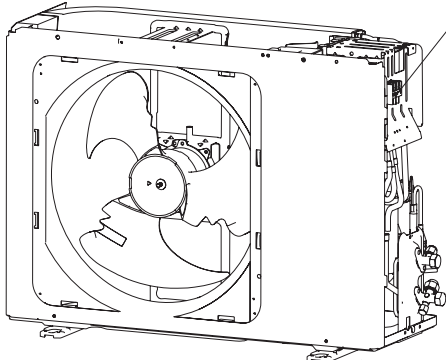
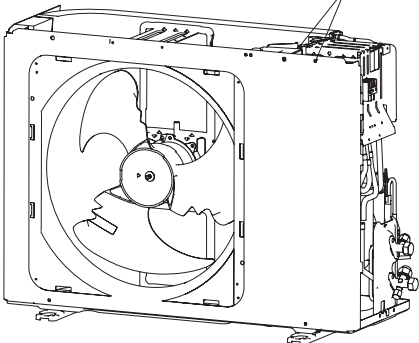
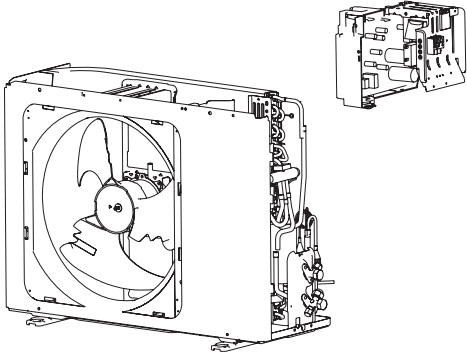
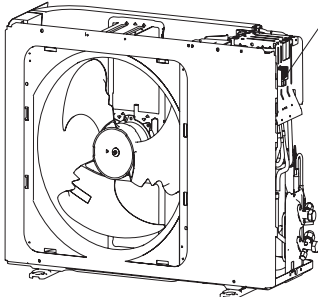
Disassembly and Assembly of electrical parts box		
Remark : Before removing the electric box or electric box sub-assembly, make sure that the power has been cut off.		
Step	Illustration	Handling Instruction
1. Remove the backside panel		Remove the backside panel away from the unit
2. Disconnect the power cord of the motor		Disconnect the motor power cord on the main board with hands or pliers.
3. Loosen the screws between the electric box and side panel and motor base.		Loosen the screws between the electric box and side panel and motor base with a screw driver.
4. Remove the electric box sub-assembly		<ul style="list-style-type: none"> ● Move the electric box sub-assembly upward from the middle isolation plate.
5. Mount a new electric box sub-assembly		<ul style="list-style-type: none"> ● Assemble the new electric box sub-assembly to correct position ● Use the screwdriver to fix the electric box sub-assembly to middle isolation plate and rear side plate according to disassembly procedures.

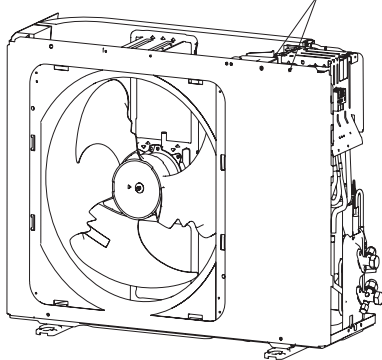
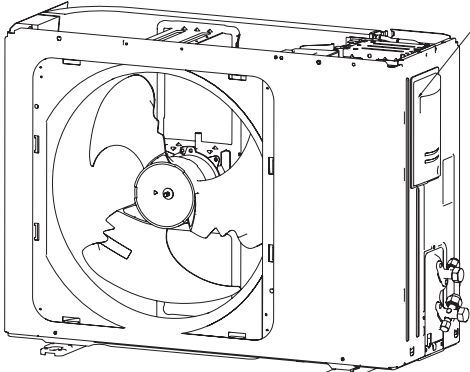
<p>6. Connect the power cable of each component</p>		<ul style="list-style-type: none"> • Connect the wires of each component to correct position according to disassembly procedures. For details, please refer to the wiring diagram.
<p>7. Place and fix the backside panel on.</p>		<p>Place and fix the backside panel on.</p>

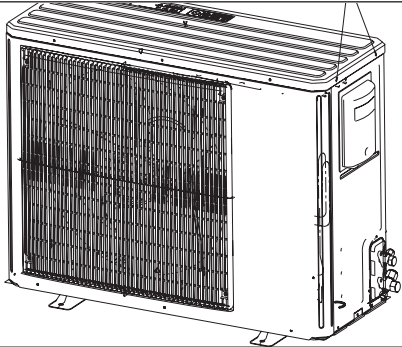
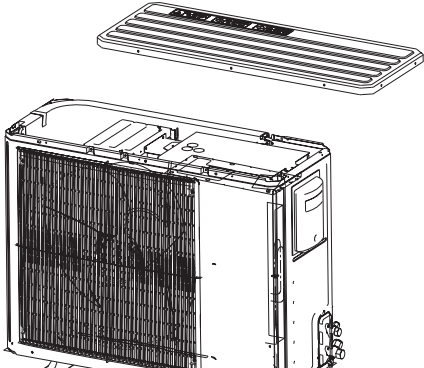
<p>Double-fan Inverter Outdoor Unit, applicable to 18KBtu/h~42 KBtu/h</p>		
<p>Disassembly and Assembly of external casing</p>		
<p>Note: Before removing the outer housing, make sure that the unit has been cut off from the power supply.</p>		
Step	Illustration	Handling Instruction
<p>1 Disassemble the top panel</p>		<p>a. Cut off the power supply b. Recover the refrigerant c. Loosen the screws on the top panel with a screw driver.</p>
<p>2 Remove the top panel</p>		<p>Remove upwards the top panel away from the unit.</p>

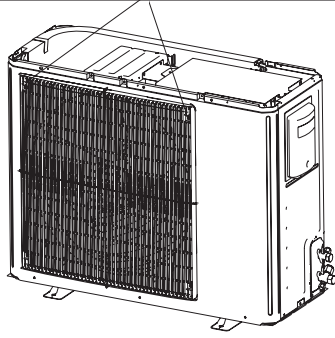
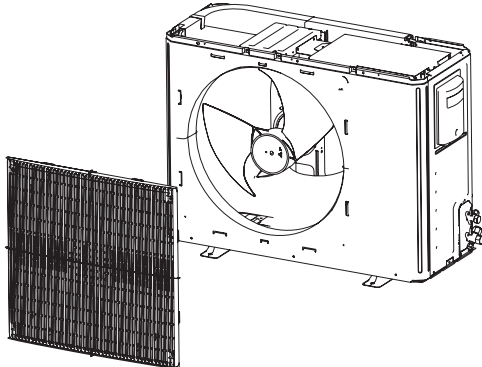
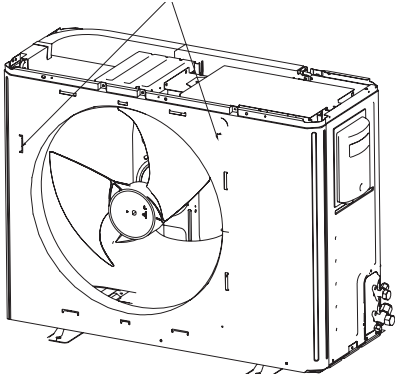
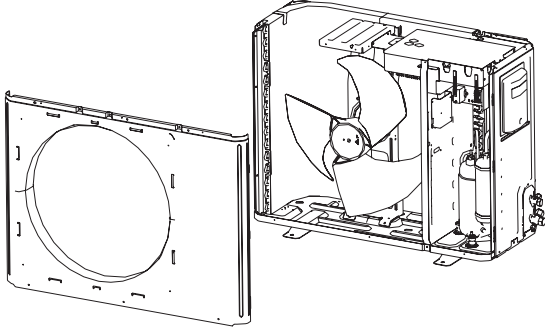
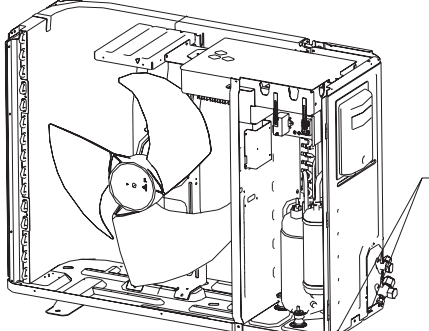
<p>3. Disassemble the grille</p>		<p>Loosen the screws on the grille with a screw driver.</p>
<p>4. Remove the grille</p>		<p>Remove the grille away from the unit .</p>
<p>5. Disassemble the back panel</p>		<p>Loosen the screws between the front panel and the partition board with a screw driver.</p>
<p>6. Remove the back panel.</p>		<p>Remove the back panel away from the unit .</p>
<p>7. Disassemble the right side panel.</p>		<p>Loosen the screws on the side panel with a screw drive.</p>

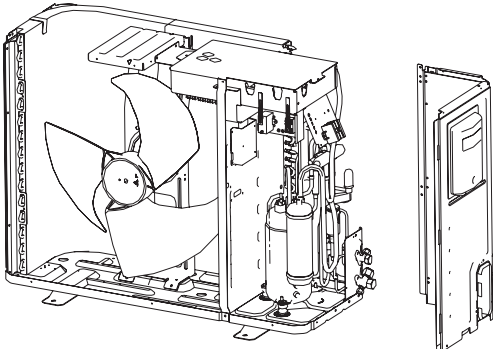
<p>8. Remove the right side panel.</p>		<p>Remove the right side panel away from the unit.</p>
--	---	--

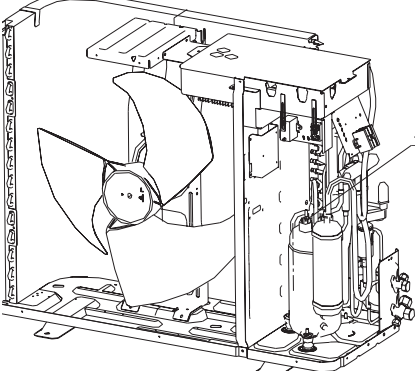
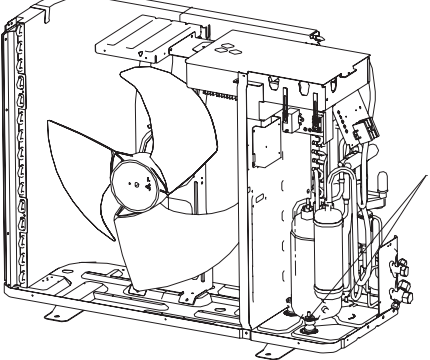
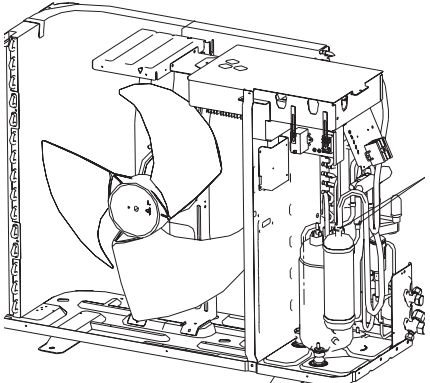
Removal and Installation of Gas-liquid Separator and Compressor		
Remark: Before removing the compressor, make sure that there is no refrigerant inside the pipe system and that the power has been cut off.		
Step	Illustration	Handling Instruction
<p>1. Disconnect the wiring of the power supply of the compressor</p>		<p>a. Open the cover of the power supply box with a wrench. b. Disconnect the power cord of the compressor with the pliers. c. Pull out the power supply plug of the compressor.</p>
<p>2. Loosen the screws on the compressor</p>		<p>Loosen the screws between the compressor and the compressor base with a wrench.</p>
<p>3. Disconnect the suction and discharge pipes of the compressor</p>		<p>a. Dismantle the gas-liquid separator through heating its inlet/outlet pipe by the means of gas welding. b. During the welding, nitrogen should be inflated and its pressure should be $0.5 \pm 0.1 \text{ kgf/cm}^3$ (relative pressure) c. Attention should be taken during the heating to avoid the surrounding objects burnt due to the high temperature.</p>

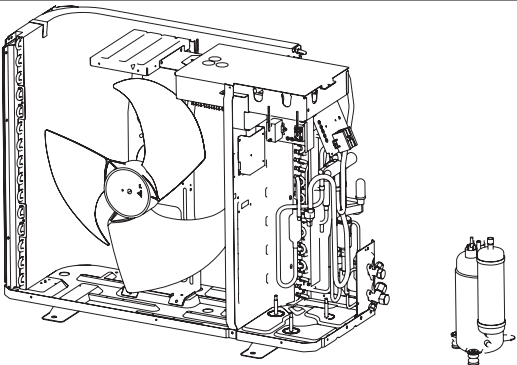
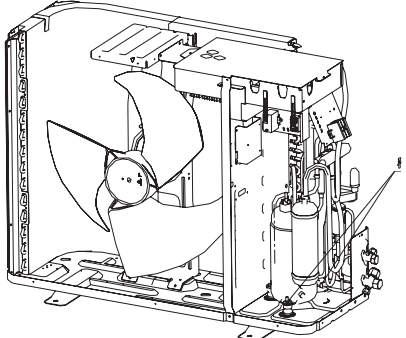
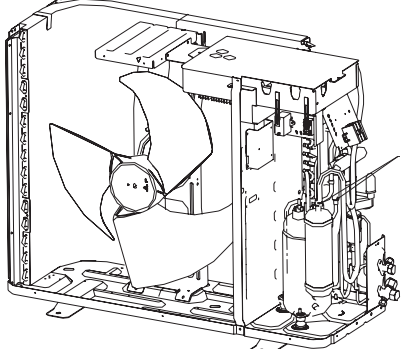
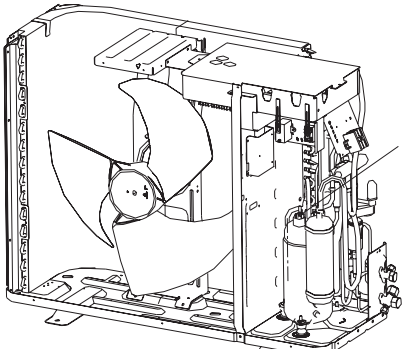
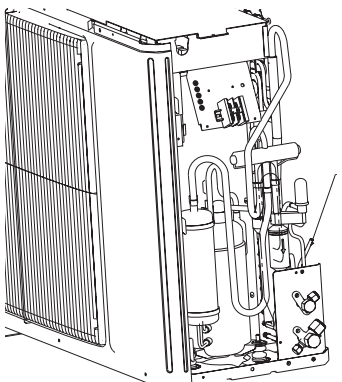
<p>4. Remove the compressor away</p>		<p>Remove the compressor away from its base.</p>
<p>5. Place the new compressor on the base</p>		<p>a. Put the new compressor in the right place. b. Tighten the screws of the compressor with a wrench c. Never put the compress upside down</p>
<p>6. Connect the suction/discharge pipes of the compressor with the system piping.</p>		<p>a. Connect the suction/discharge pipes of the compressor by means of gas welding. b. During the welding, nitrogen should be inflated and its pressure should be $0.5 \pm 0.1 \text{ kgf/cm}^3$ (relative pressure) c. Attention should be taken during the heating to avoid the surrounding objects burnt due to the high temperature.</p>
<p>7. Connect the power cord of the compressor</p>		<p>a. Connect the power cord as the reverse way of disconnection mentioned above. b. Tighten the cover of the compressor with a screw driver.</p>
<p>8. Establish vacuum through liquid valve</p>		<p>Establish vacuum inside the system through liquid valve.</p>

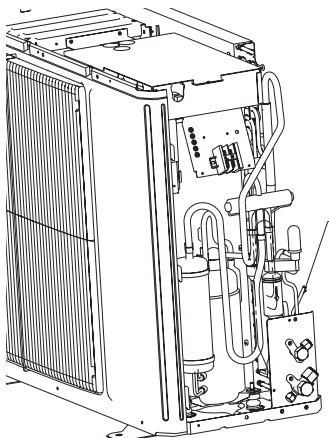
<p>9. Charge refrigerant through liquid valve</p>		<p>Recharge the refrigerant to the system through liquid valve.</p> <p>The charge volume must be identical to the indications on nameplate.</p>
---	---	---

Disassembly and Assembly of 4-way valve
 Note: Before removing the 4-way valve, make sure that there is no refrigerant inside the pipe system and that the power has been cut off.

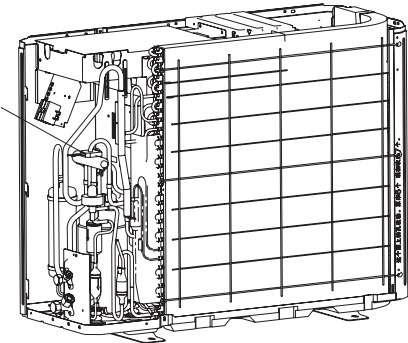
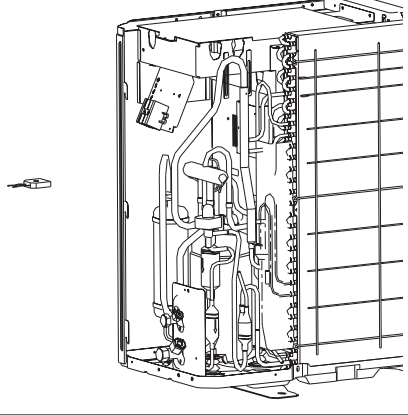
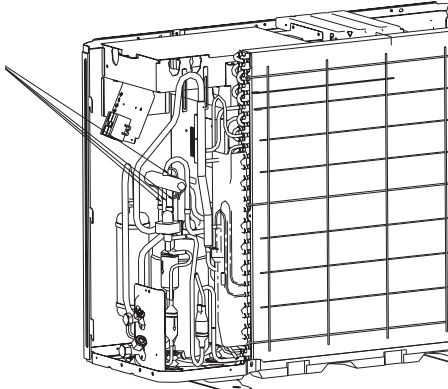
Step	Illustration	Handling Instruction
<p>1. Loosen the solenoid valve</p>		<p>a. Cut off the power supply b. Recover the refrigerant. c. Loosen the bolts on the solenoid valve with a wrench.</p>
<p>2. Remove the solenoid valve</p>		<p>Remove the solenoid away from the four-way valve.</p>
<p>3. Remove the 4-way valve</p>		<ul style="list-style-type: none"> ● Use gas welding to heat the pipes connected on the four openings of 4-way valve. Then, pull them out from 4-way valve. ● Before welding 4-way valve, please record the orientation of 4-way valve and installing position of each opening.

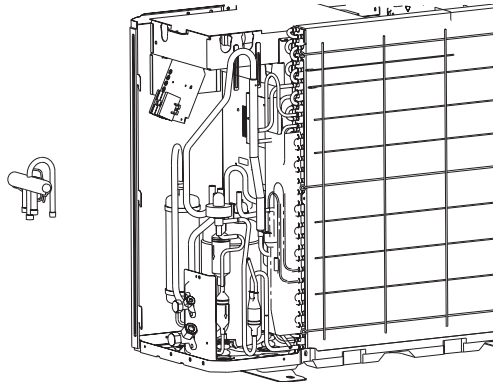
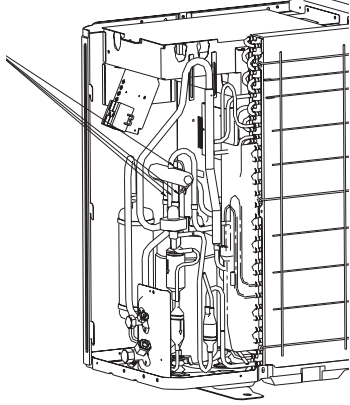
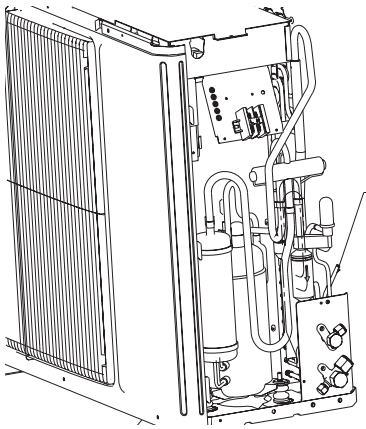
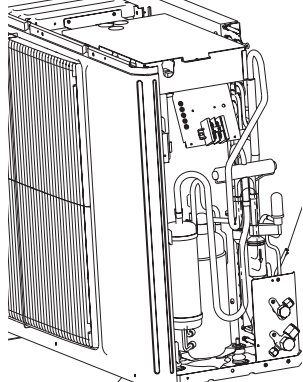
<p>4. Remove 4-way valve</p>		<ul style="list-style-type: none"> ● Remove the old 4-way valve from the unit.
<p>5. Connect the new 4-way valve to the pipe.</p>		<ul style="list-style-type: none"> ● Install the new 4-way valve to correct position. ● When welding the 4-way valve, please wrap the valve body with wet cloth, thus to prevent the guide inside the valve body from burn. Also take care to prevent any water from flowing into the pipe. ● Weld by charging nitrogen, with the nitrogen pressure kept at $0.5 \pm 0.1 \text{ kgf/c}$ (relative pressure).
<p>6. Establish vacuum inside the system through liquid valve.</p>		<ul style="list-style-type: none"> ● Establish vacuum inside the system through liquid valve.
<p>7 Recharge the refrigerant to the system through liquid valve.</p>		<ul style="list-style-type: none"> ● Recharge the refrigerant to the system through liquid valve. ● The charge volume must be identical to the indications on nameplate.

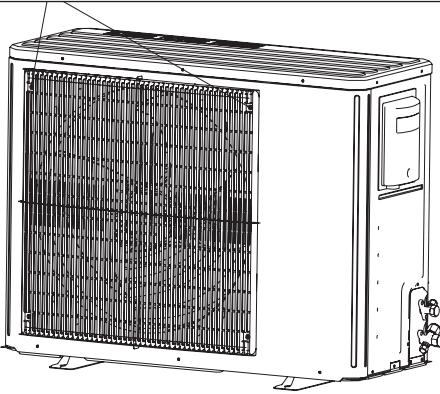
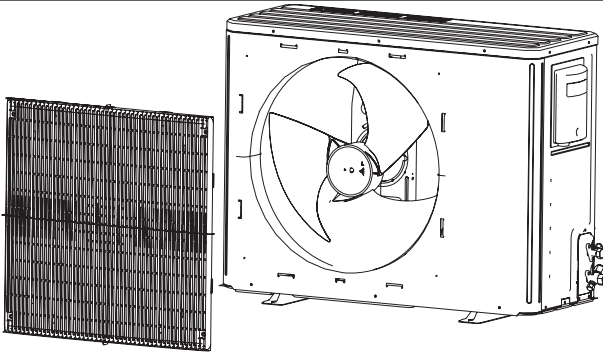
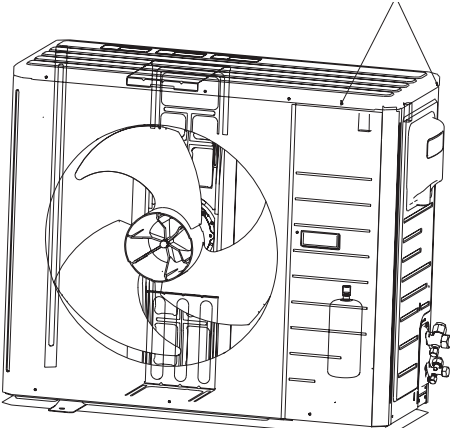
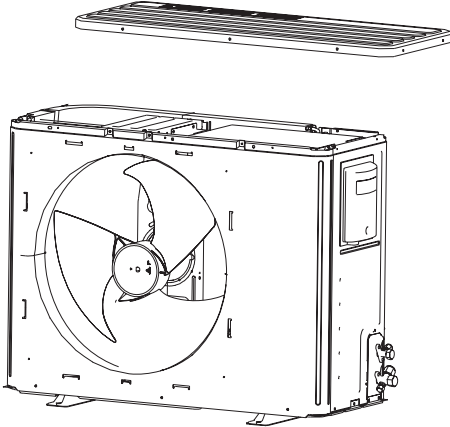
Removal and Installation of Fan and Motor		
Note : Before the dismantlement of the motor, make sure the unit is powered off.		
Step	Illustration	Handling Instruction
1 Loosen the grille.		Loosen the screws between the grille and the back panel with a screw driver.
2. Remove the grille		Remove the grill away from the back panel.
3. Loosen the top panel		Loosen the screws on the top panel with a screw driver.
4. Remove the electric box cover		<ul style="list-style-type: none"> ●Use screwdriver to loosen the screws on electric box cover. ●Remove the cover from electric box.

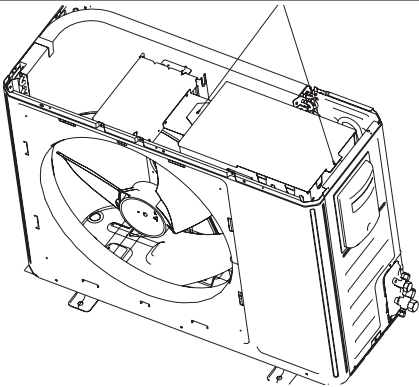
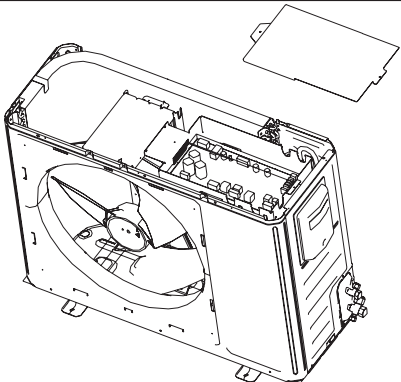
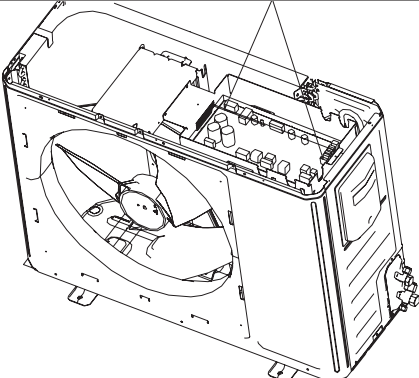
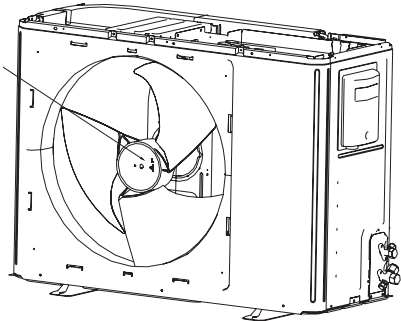
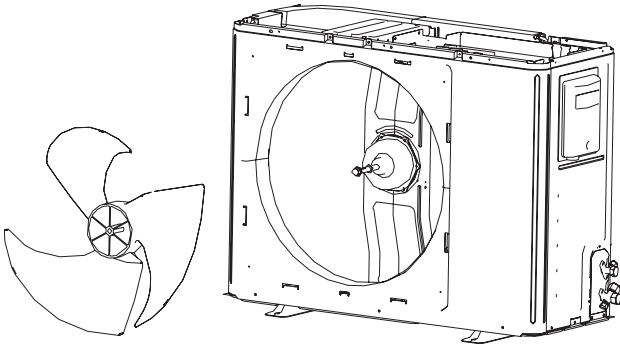
<p>5. Loosen the backside panel</p>		<p>Loosen the screws on the backside panel with a screw driver.</p>
<p>6. Remove the rear side plate.</p>		<p>Remove the rear side plate away from the unit</p>
<p>7. Disconnect the power cord of the motor</p>		<p>Disconnect the motor power cord on the main board with hands or pliers</p>
<p>8 Remove the fan from motor</p>		<p>Remove the fan from motor.</p>
<p>9. Remove the fan blades</p>		<p>Remove the fan blades away from the motor.</p>

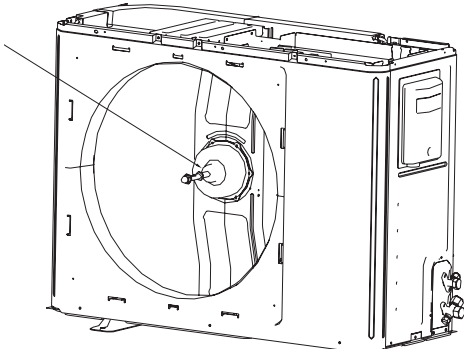
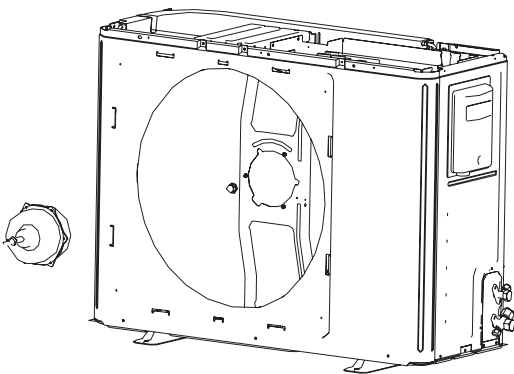
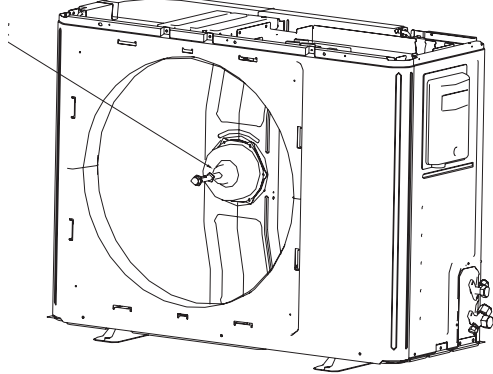
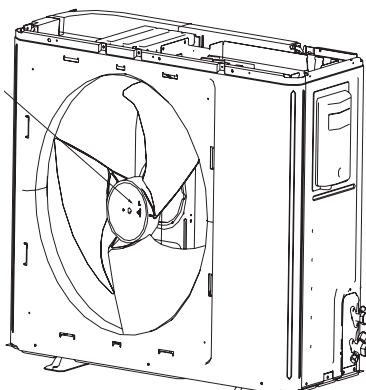
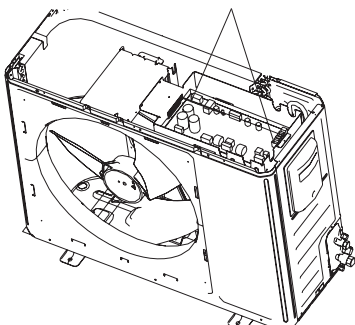
<p>10. Loosen the motor</p>		<p>Loosen the bolts on the motor with a wrench.</p>
<p>11. Remove the motor</p>		<ul style="list-style-type: none"> ●Use spanner and screwdriver to remove the bolts fixing the motor. ●Remove the motor from motor support.
<p>12. Install a new motor to motor support</p>		<ul style="list-style-type: none"> ●Put the new motor to correct position. ●Use spanner and screwdriver to fix the motor to motor support with bolts.
<p>13. Assemble the fan</p>		<ul style="list-style-type: none"> ●Assemble the axial flow fan to correct position and fix it to the motor shaft in reverse to the disassembly procedures. ●Put the electric box cover to correct position and fix it onto the electric box according to disassembly procedures.
<p>14. Connect the motor power cable</p>		<ul style="list-style-type: none"> ●Connect the insert of motor power cable to the mainboard terminal in reverse to the disassembly procedures.

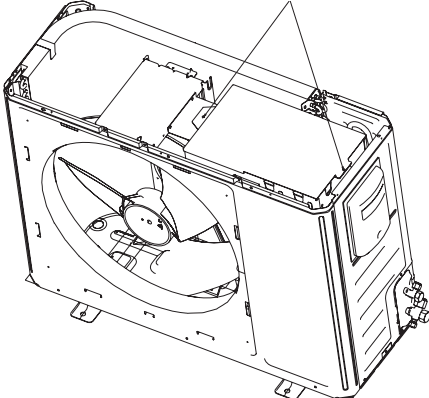
<p>15. Assemble the electric box cover</p>		<ul style="list-style-type: none"> ● Assemble the electric box cover to correct position ● Use screwdriver to fix the cover onto electric box.
--	---	--

Removal and Installation of Electronic Expansion Valve

Note : Before removing the compressor, make sure that there is no refrigerant inside the pipe system and that the power has been cut off.

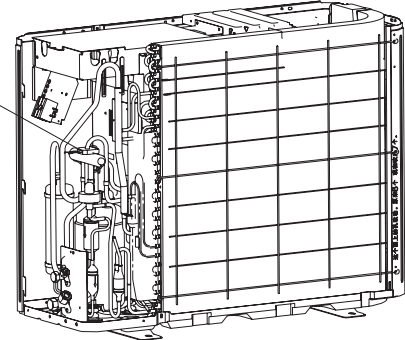
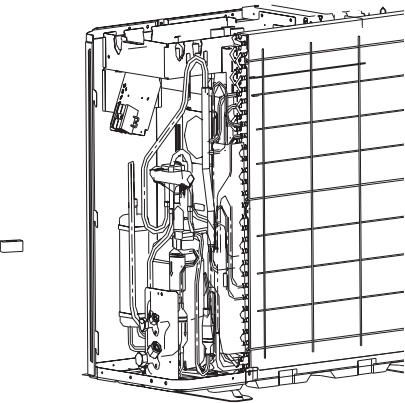
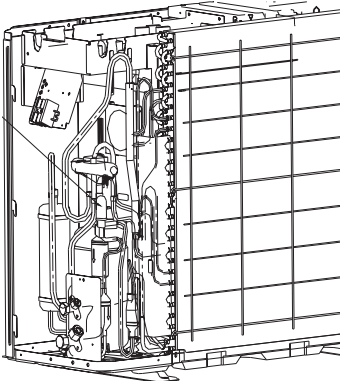
Step	Illustration	Handling Instruction
<p>1. Loosen the electric expand valve fitting</p>		<p>Loosen the coil of the electric expansion valve.</p>
<p>2 Remove the electric expand valve fitting</p>		<p>Remove the coil of the electric expansion valve.</p>
<p>3 Remove electric expansion valve</p>		<p>A. Unsolder the connecting pipes on both sides of the electric expansion valve. Pull off the electric expansion valve. B. During soldering, charge nitrogen with pressure of $0.5 \pm 0.1 \text{ kgf/cm}^2$ (relative pressure) C. Do not burn the surrounding material during heating.</p>

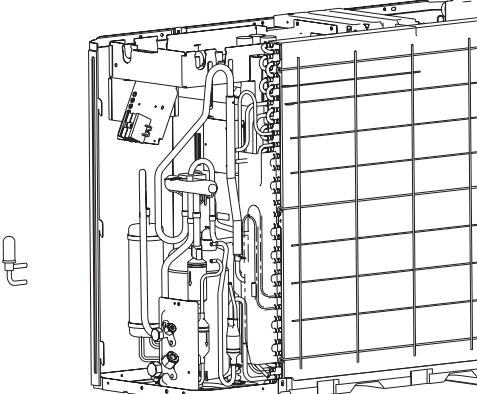
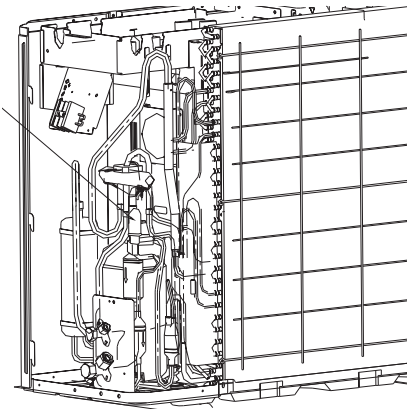
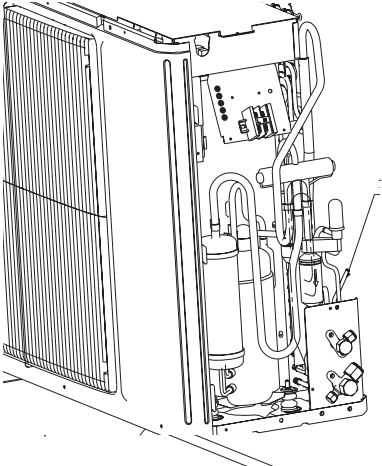
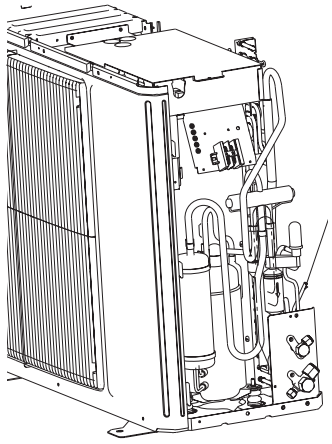
<p>4.Remove the old expansion valve.</p>		<p>Remove the old expansion valve.</p>
<p>5. Install a new electric expansion valve and connect it to system</p>		<p>A.Weld the electric expansion valve B.During soldering, charge nitrogen with pressure of $0.5\pm 0.1\text{kgf/cm}^2$ (relative pressure) C.Do not burn the surrounding material during heating.</p>
<p>6.Establish vacuum inside the system through liquid valve.</p>		<ul style="list-style-type: none"> • Establish vacuum inside the system through liquid valve.
<p>7.Recharge the refrigerant to the system through liquid valve.</p>		<ul style="list-style-type: none"> • Recharge the refrigerant to the system through liquid valve. • The charge volume must be identical to the indications on nameplate.

Double-fan Inverter Outdoor Unit, applicable to 48KBtu/h~60 KBtu/h

Disassembly and Assembly of external casing .

Note: Before removing the outer housing, make sure that the unit has been cut off from the power supply.

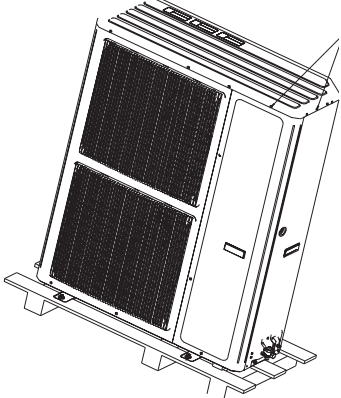
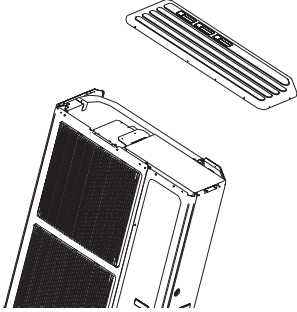
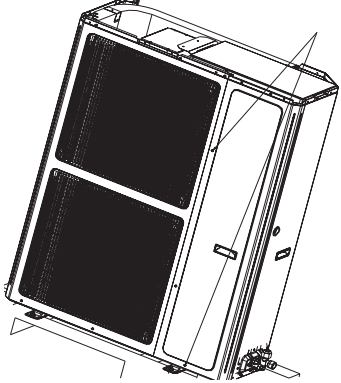
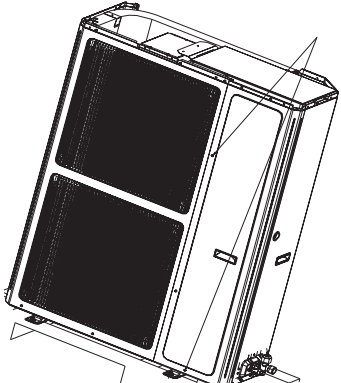
Step	Illustration	Handling Instruction
1 Disassemble the top panel		<p>a. Cut off the power supply b. Recover the refrigerant c. Loosen the screws on the top panel with a screw driver.</p>
2 Remove the top panel		<p>Remove upwards the top panel away from the unit.</p>
3. Remove the front side plate,		<p>Looson the screws on the front side plate.</p>
4. Remove the front side plate		<p>Remove front side plate</p>

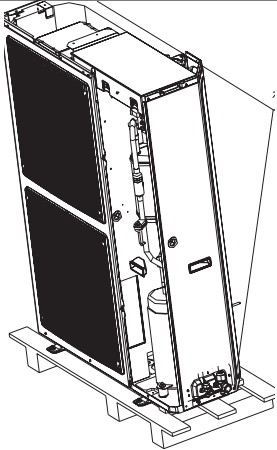
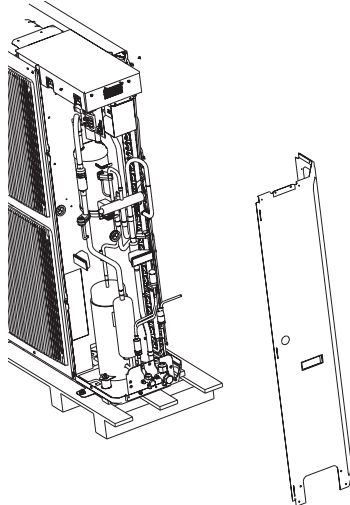
<p>5. Loosen the back side plate</p>		<p>Loosen the screws fixing the back side plate.</p>
<p>6. Remove the backside plate</p>		<p>Remove the back side plate.</p>

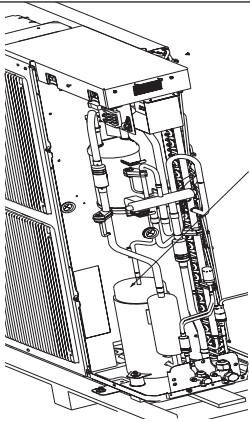
Removal and Installation of Gas-liquid Separator and Compressor		
Remark: Before removing the compressor, make sure that there is no refrigerant inside the pipe system and that the power has been cut off.		
Step	Illustration	Handling Instruction
<p>1. Remove power connecting wire of compressor</p>		<p>A. Loosen the power box cover of the compressor. B. Pull out the power connecting wire of the compressor. C. Remove the power insert of the compressor</p>

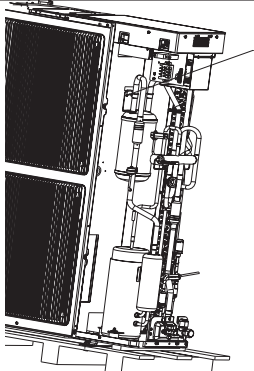
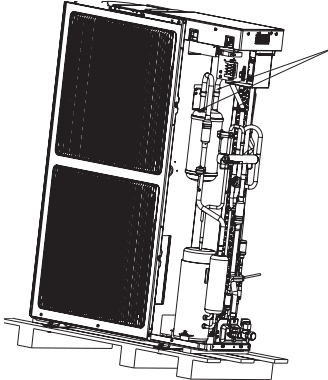
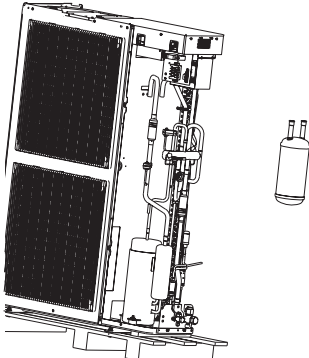
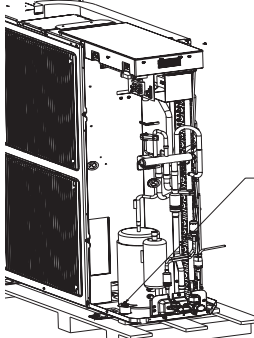
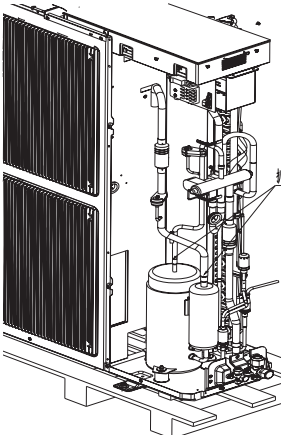
<p>2. Remove the screw fixing the gas-liquid separator</p>		<p>Remove the screw fixing the gas-liquid separator.</p>
<p>3. Remove the inlet pipe and outlet pipe of gas-liquid separator</p>		<p>A. Unsolder the inlet pipe and outlet pipe of the gas-liquid separator. B. During soldering, charge nitrogen with pressure of $0.5 \pm 0.1 \text{ kgf/cm}^2$ (relative pressure) C. Do not burn the surrounding material during heating.</p>
<p>4. Remove the gas-liquid separator.</p>		<p>Remove the gas-liquid separator.</p>
<p>5. Remove the screws fixing the compressor.</p>		<p>Remove the screws fixing the compressor.</p>
<p>6. Remove the air inlet pipe and the outlet pipe of the compressor</p>		<p>A. Unsolder the inlet pipe and outlet pipe of the gas-liquid separator. B. During soldering, charge nitrogen with pressure of $0.5 \pm 0.1 \text{ kgf/cm}^2$ (relative pressure) C. Do not burn the surrounding material during heating.</p>

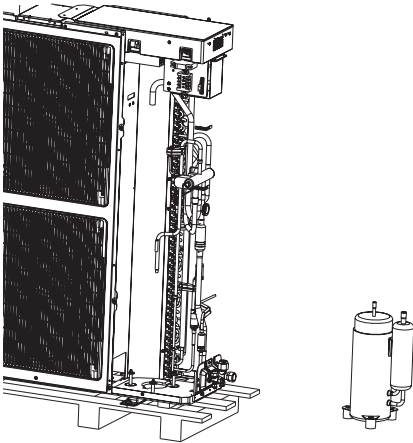
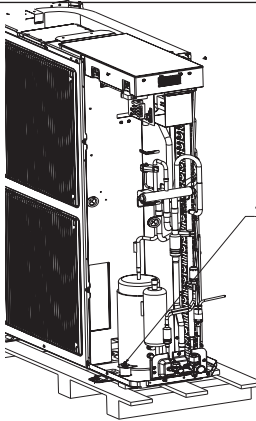
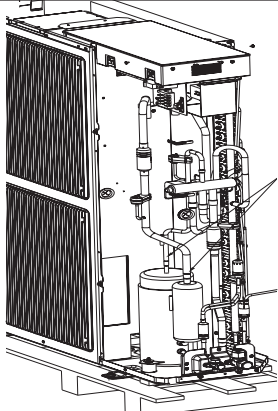
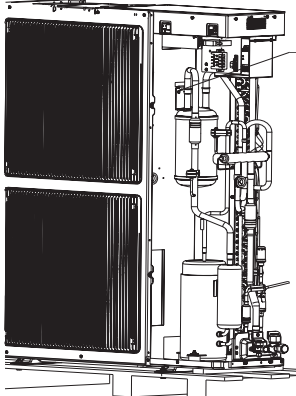
<p>7. Remove the compressor .</p>		<p>Remove the compressor from the compressor support.</p>
<p>8. Install a new compressor on the compressor support.</p>		<p>A. Put a new compressor in the right place. B. Tighten the nuts fixing the compressor. C. The compressor should not be up-side down.</p>
<p>9. Connect the pipes of the compressor to the system .</p>		<p>A. Weld the pipes of the compressor. B. During soldering, charge nitrogen with pressure of $0.5 \pm 0.1 \text{ kg/cm}^2$ (relative pressure) C. Do not burn the surrounding material during heating.</p>
<p>10. Install a gas-liquid separator and fix it .</p>		<p>A. Put the gas-liquid separator in the right place. B. Tighten the screws fixing the gas-liquid separator and the isolation sheet.</p>

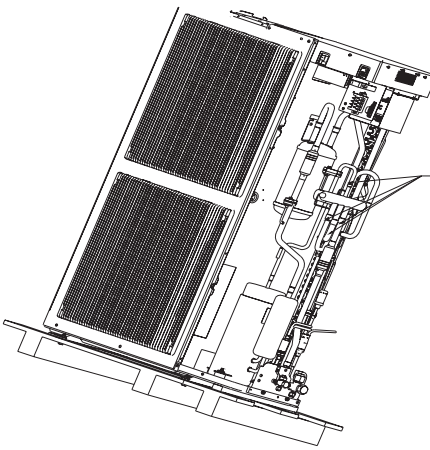
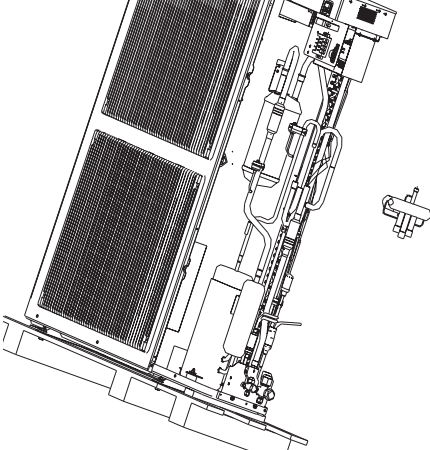
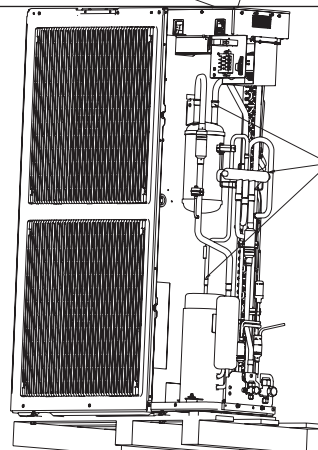
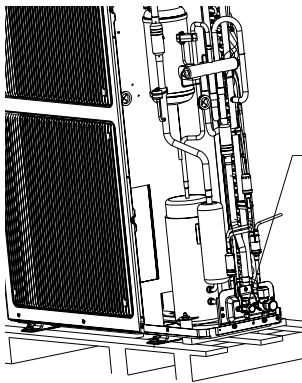
Disassembly and Assembly of 4-way valve		
Note: Before removing the 4-way valve, make sure that there is no refrigerant inside the pipe system and that the power has been cut off.		
Step	Illustration	Handling Instruction
1. Remove the 4-way valve		<ul style="list-style-type: none"> ● Use gas welding to heat the pipes connected on the four openings of 4-way valve. Then, pull them out from 4-way valve. ● Before welding 4-way valve, please record the orientation of 4-way valve and installing position of each opening.
2. Remove 4-way valve		<ul style="list-style-type: none"> ● Remove the old 4-way valve from the unit.
3. Connect the new 4-way valve to the pipe.		<ul style="list-style-type: none"> ● Install the new 4-way valve to correct position. ● When welding the 4-way valve, please wrap the valve body with wet cloth, thus to prevent the guide inside the valve body from burn. Also take care to prevent any water from flowing into the pipe. ● Weld by charging nitrogen, with the nitrogen pressure kept at $0.5 \pm 0.1 \text{ kgf/cm}^2$ (relative pressure).
4. Establish vacuum inside the system through liquid valve.		<ul style="list-style-type: none"> ● Establish vacuum inside the system through liquid valve.

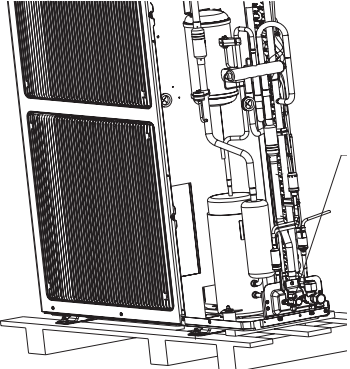
<p>5. Recharge the refrigerant to the system through liquid valve.</p>		<ul style="list-style-type: none"> ● Recharge the refrigerant to the system through liquid valve. ● The charge volume must be identical to the indications on nameplate.
--	---	--

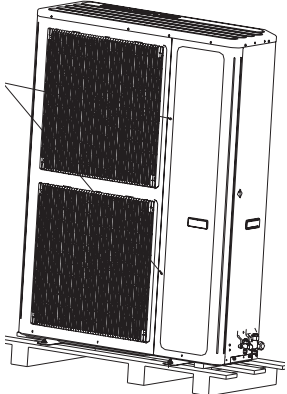
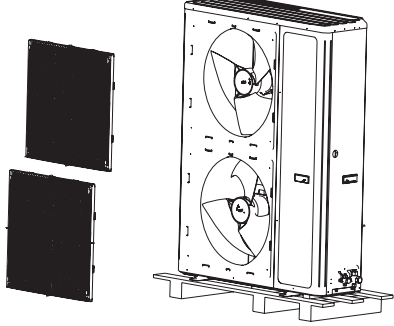
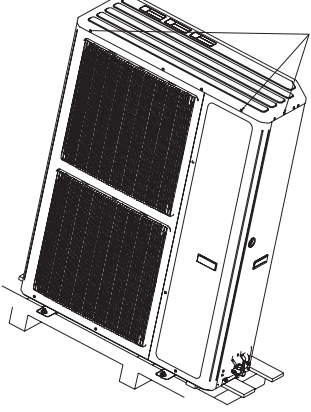
Removal and Installation of Fan and Motor		
Note : Before the dismantlement of the motor, make sure the unit is powered off.		
Step	Illustration	Handling Instruction
<p>1. Loosen the front grille</p>		<p>Loosen the screws fixing the front grille and the panel.</p>
<p>2. Remove the front grille</p>		<p>Remove the front grille from the unit.</p>
<p>3. Remove the top cover</p>		<p>Loosen the screws fixing the top cover.</p>

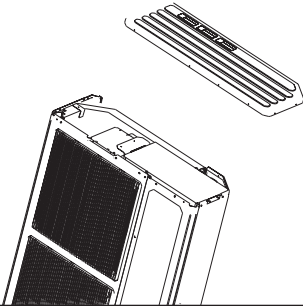
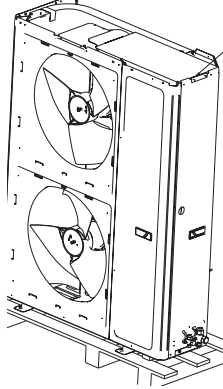
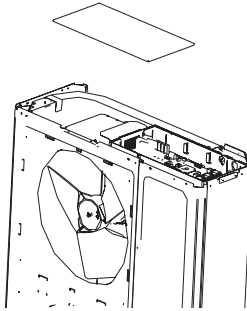
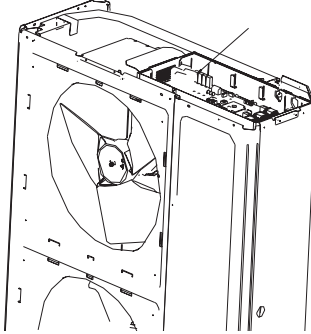
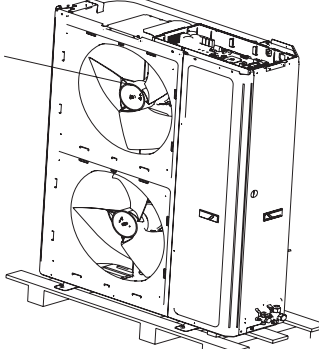
<p>4. Remove the electric box cover</p>		<ul style="list-style-type: none"> ●Use screwdriver to loosen the screws on electric box cover. ●Remove the cover from electric box.
<p>5. Remove the motor power cable</p>		<ul style="list-style-type: none"> ●Use hand or forceps to pull out the motor power cable from mainboard. (Note: Before removal, please mark the insert position of the upper and lower motor power cables correctly).
<p>6. Remove the electronic box cover</p>		<p>Remove the electric box cover from the electric box.</p>
<p>7. Remove the power cord of the motor</p>		<p>Pull out the power cord of the motor from the mainboard.</p>
<p>8. Remove the axial flow fan</p>		<ul style="list-style-type: none"> ● Hold the fan and do not let it run ● Use spanner to remove the tightening nuts fixing the fan.

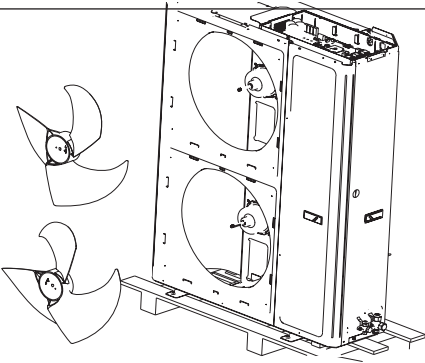
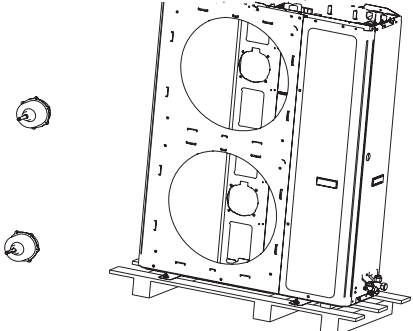
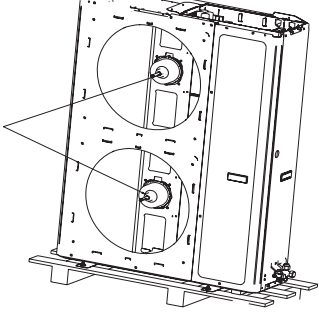
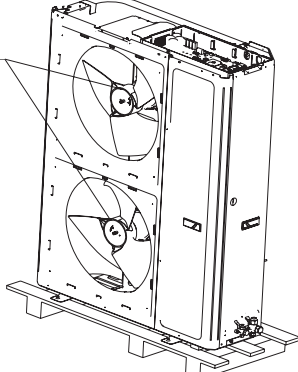
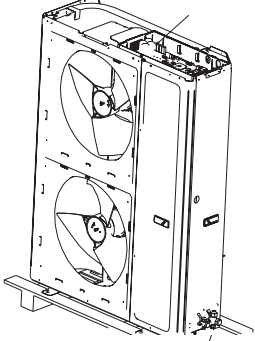
<p>9. Remove the fan from motor</p>		<p>Remove the fan from motor.</p>
<p>10. Remove the motor</p>		<ul style="list-style-type: none"> ● Use spanner and screwdriver to remove the bolts fixing the motor. ● Remove the motor from motor support.
<p>11. Install a new motor to motor support</p>		<ul style="list-style-type: none"> ● Put the new motor to correct position. ● Use spanner and screwdriver to fix the motor to motor support with bolts.
<p>12. Assemble the fan</p>		<ul style="list-style-type: none"> ● Assemble the axial flow fan to correct position and fix it to the motor shaft in reverse to the disassembly procedures. ● Put the electric box cover to correct position and fix it onto the electric box according to disassembly procedures.
<p>13. Connect the motor power cable</p>		<ul style="list-style-type: none"> ● Connect the insert of motor power cable to the mainboard terminal in reverse to the disassembly procedures.

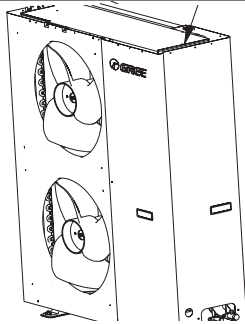
<p>14. Assemble the electric box cover</p>		<ul style="list-style-type: none"> ● Assemble the electric box cover to correct position. ● Use screwdriver to fix the cover onto electric box.
--	---	---

Removal and Installation of Electronic Expansion Valve

Note : Before removing the compressor, make sure that there is no refrigerant inside the pipe system and that the power has been cut off.

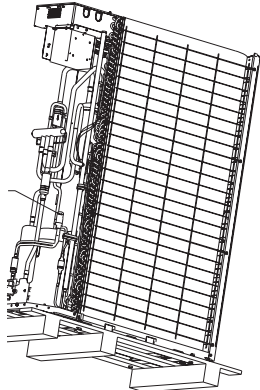
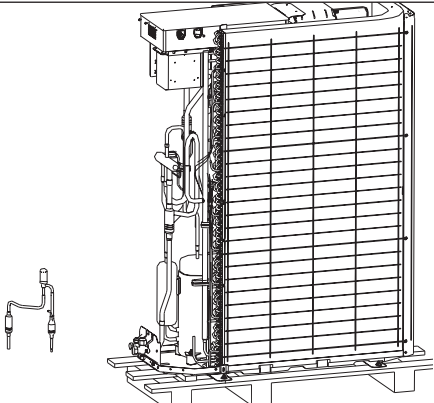
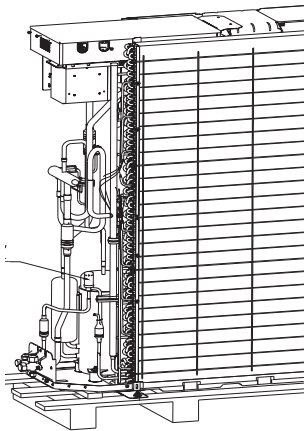
Step	Illustration	Handling Instruction
<p>1. Loosen the electric expand valve fitting</p>		<p>A Unsolder the connecting pipes on both sides of the electric expansion valve. Pull off the electric expansion valve. B. During soldering, charge nitrogen with pressure of $0.5 \pm 0.1 \text{ kgf/cm}^2$ (relative pressure) C . Do not burn the surrounding material during heating.</p>
<p>2. Remove the old expansion valve.</p>		<p>Remove the old expansion valve.</p>
<p>3. Install a new electric expansion valve and connect it to system</p>		<p>A. Weld the electric expansion valve B. During soldering, charge nitrogen with pressure of $0.5 \pm 0.1 \text{ kgf/cm}^2$ (relative pressure) C. Do not burn the surrounding material during heating.</p>

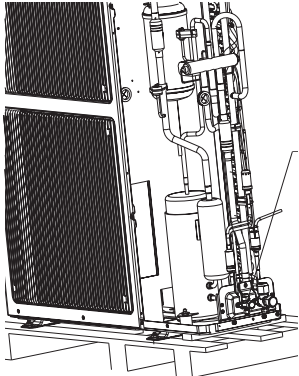
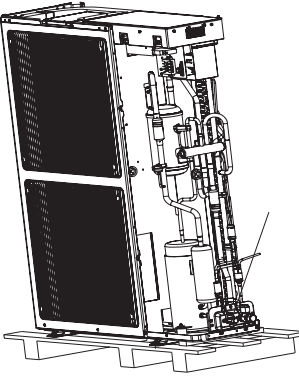
<p>4. Establish vacuum inside the system through liquid valve.</p>		<p>Establish vacuum inside the system through liquid valve.</p>
<p>5. Recharge the refrigerant to the system through liquid valve.</p>		<ul style="list-style-type: none"> • Recharge the refrigerant to the system through liquid valve. • The charge volume must be identical to the indications on nameplate.

Disassembly and Assembly of electrical parts box

Note: Before removing the 4-way valve, make sure that there is no refrigerant inside the pipe system and that the power has been cut off.

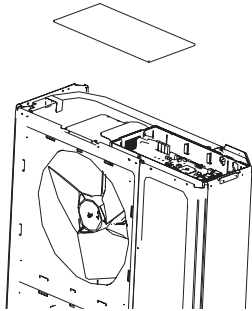
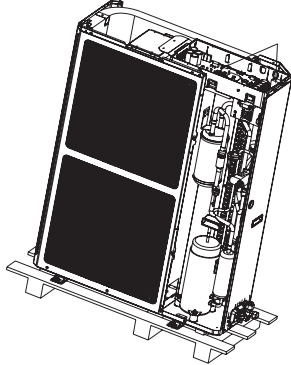
Step	Illustration	Handling Instruction
<p>1. Remove the electric box cover</p>		<ul style="list-style-type: none"> • Cut off the power. • Use the screwdriver to remove the fixing screws between electric box cover and electric box. • Remove the cover from electric box.
<p>2. Remove the power cord of the electric box</p>		<p>Remove the power cord of the electric box .</p>

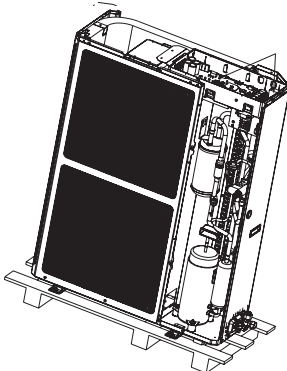
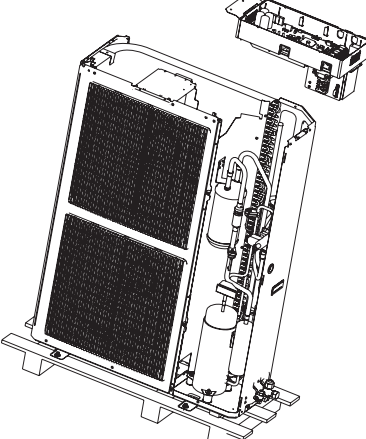
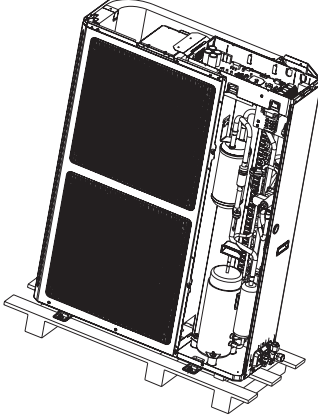
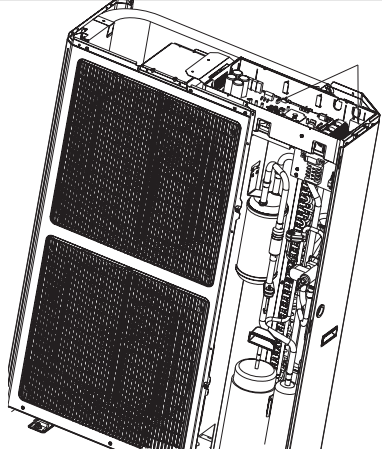
<p>3. Loosen the screws between the electric box and side panel and motor base.</p>		<p>Loosen the screws between the electric box and side panel and motor base with a screw driver.</p>
<p>4. Remove the electric box sub-assembly</p>		<ul style="list-style-type: none">• Move the electric box sub-assembly upward from the middle isolation plate.
<p>5. Mount a new electric box sub-assembly</p>		<ul style="list-style-type: none">• Assemble the new electric box sub-assembly to correct position• Use the screwdriver to fix the electric box sub-assembly to middle isolation plate and rear side plate according to disassembly procedures.
<p>6. Connect the power cable of each component</p>		<ul style="list-style-type: none">• Connect the wires of each component to correct position according to disassembly procedures. For details, please refer to the wiring diagram.

7. Assemble the electric box cover.

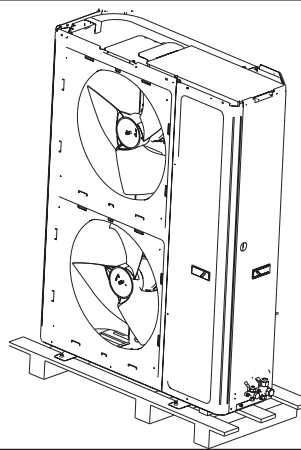

- Assemble the electric box cover to correct position and use screwdriver to tighten the fixing screws.

4.2. Indoor Unit

4.2.1 Duct type

For GFH09K3CI /GFH12K3CI/GFH18K3CI

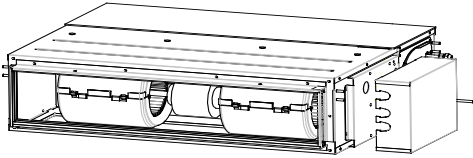
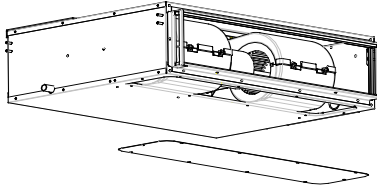
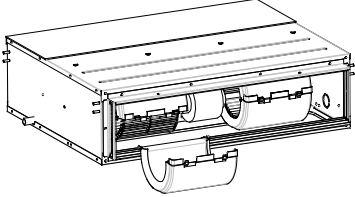
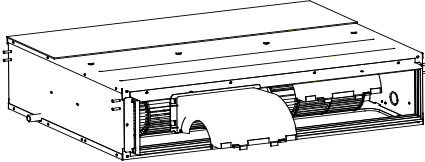
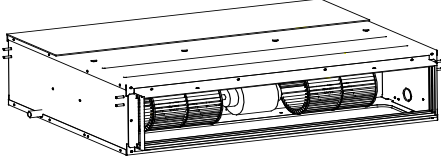
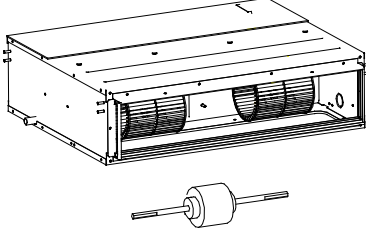
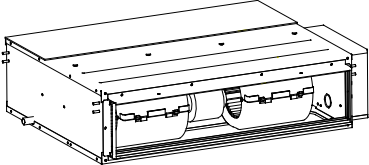
Removal and Assembly of Fan Motor		
Remarks: Before removing the fan, make sure to cut off the power firstly.		
Step	Illustration	Handling Instruction
1. Unplug the motor cables		Cut off the power supply of indoor unit. Use screwdriver to remove the electric box cover and unplug the motor cables in electric box.
2. Remove the filter sub-assembly and air inlet cover board		Remove the filter sub-assembly from the air inlet frame and use screwdriver to remove the air inlet cover board.
3. Remove the screws on fan sub-assembly.		Remove the screws on fan sub-assembly.
4. Overturn the propeller housing		Rotate the propeller housing to the air inlet according to arrow direction.
5. Loosen the fan and motor.		Use inner hexagonal spanner to loosen the screws on fan and remove the clamp fixing the motor.
6. Replace the motor		Firstly, disengage the motor from motor support. Then, sequentially disengage the fan sub-assembly from the motor shaft. Remove the motor from the air inlet and replace with new motor. In which, for the motor with automatic motor support, the motor support shall be removed in advance and then changed to the unit.
7. Assemble the unit in reverse to the disassembly procedures		Assemble the unit in reverse to the disassembly procedures and energize it for testing.

For GFH24K3CI/GFH30K3CI/GFH36K3CI/GFH42K3CI/GFH48K3CI/GFH60K3CI

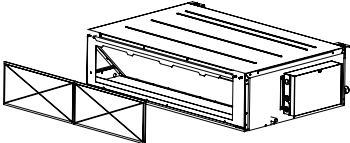
Disassembly of filter screen for return air.		
Remark: Make sure that the power supply is cut off before disassembling and protect all the parts during disassembly. Do not put filter screen near the high temperature heat source.		
Step	Illustration	Handling Instruction
1. Disassembly of filter screen for return air		Compress the filter screen for return air down on the guide slot sponge, and remove according to the direction shown by the arrow. There are 2 filter screen for return air.

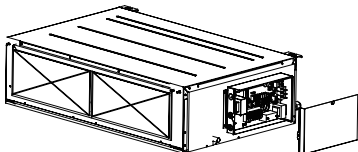
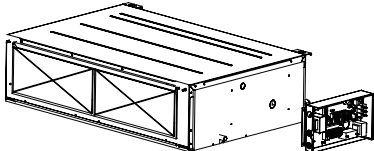
Disassembly of electrical parts box cover panel and electrical parts box		
Remark: Make sure that the power supply is cut off before disassembling and protect all the parts during disassembly, especially the electrical components. Do not dampen or hit them		
Step	Illustration	Handling Instruction
2. Disassembly of electric box cover		Disassemble the screw according to the position shown in the circle and the box and remove the electric box in the direction of the arrow.
3. Disassembly of electric parts box		Disassemble the fastening screw and remove the electrical parts box. (As is shown in the graph, there are 2 fastening screws in the circle and the screws in the direction of arrow shall be disassembled too.)

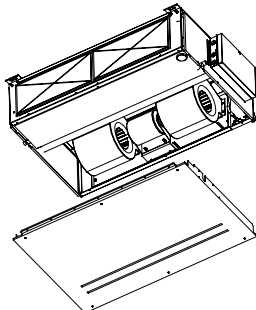
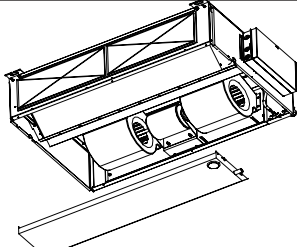
Disassembly of water-containing plate		
Remark: Make sure that the power supply is cut off before disassembling and protect all the parts during disassembly.		
Step	Illustration	Handling Instruction
4. Disassembly of cover plate		Disassemble the fastening screws on the cover plate and remove the cover plate. (As is shown in the graph, circle represents 6 fastening screws under the cover plate and the box represents two fastening screws on water-containing plate symmetrically arranged both on left and right.)
5. Disassembly of water-containing plate		Disassemble the fastening screws on the water-containing plate, pull upward and remove the water-containing plate. Disassembled water-containing plate is shown in the graph.

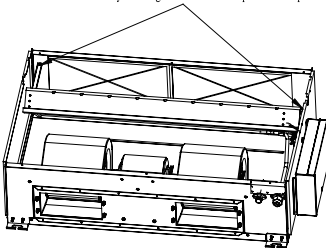
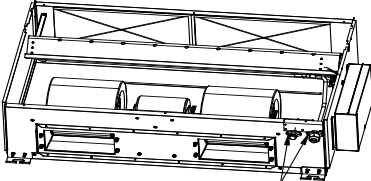
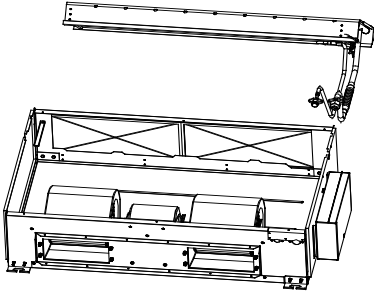
Disassembly of evaporator		
Remark: Make sure that the power supply is cut off and protect the copper tube and aluminum fin. If the time for disassembly shall be long, put the copper tube under pressurized condition.		
Step	Illustration	Handling Instruction
1. Disassembly of fixing screws on the side panels of evaporator	<p>Disassembly of fixing screws on the side panels of evaporator</p> 	Disassemble the fastening screw connecting left and right side panels on the evaporator and the upper cover plate. (As is shown in the arrows direction in Graph .)
2. Disassemble fastening screws connecting evaporator valve seal-plate and joint flange	 <p>Disassemble fastening screws connecting evaporator valve seal-plate and joint flange</p>	Disassemble the fastening screws on the valve seal-plate and remove the valve seal-plate. Disassemble the fastening screws on the evaporators joint flange. (As is shown in the graph, box represents fastening screws on seal-plates while circle the fastening screws on joining flange.
3. Removal of evaporator		Remove the evaporator. Removed evaporator is shown in the graph.

4.2.2Cassette-type Unit

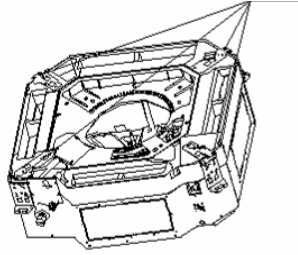
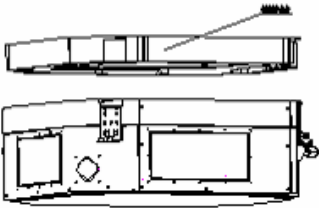
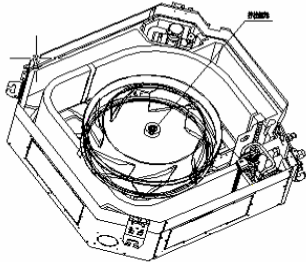
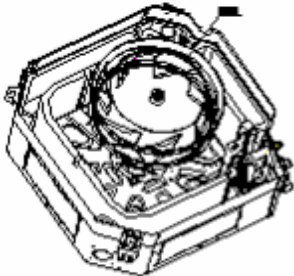
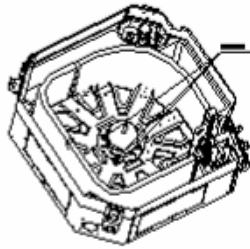
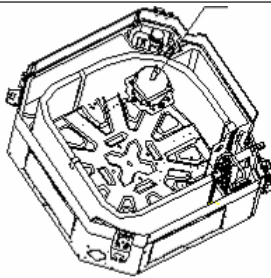
Removal and Assembly of Fan Motor.		
Step	Illustration	Handling Instruction
1. Loosen the screws fixing the water tray		Use screwdriver to loosen the screws fixing the water tray.
2. Remove the water tray		Remove the water tray.
3. Loosen the bolts fixing the fan		Use spanner to loosen the bolts fixing the fan.
4. Remove the fan		Remove the fan.
5. Loosen the screws fixing the motor		Use screwdriver to loosen the screws fixing the motor
6. Remove the motor and replace it		Remove the motor and replace it.

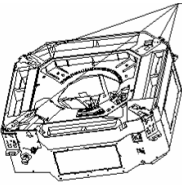
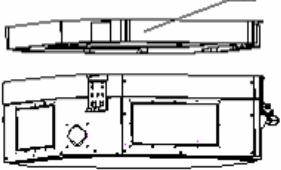
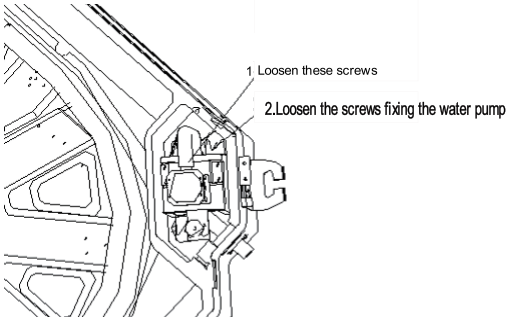
Removal and Installation of Drainage Pump		
Step	Illustration	Handling Instruction
1. Loosen the screws fixing the water tray		Use screwdriver to loosen the screws fixing the water tray.
2. Remove the water tray		Remove the water pump and replace it.
3. Pull out the water outlet pipe and loosen the screws fixing the water pump.		Pull out the water outlet pipe and use screwdriver to loosen the screws fixing the water pump.

4.2.3 Floor Ceiling Type

Model: GTH09K3CI/GTH12K3CI/GTH18K3CI/GTH24K3CI/GTH30K3CI/GTH36K3CI/GTH42K3CI

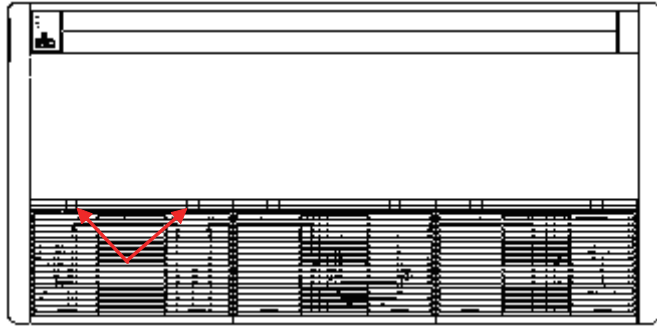
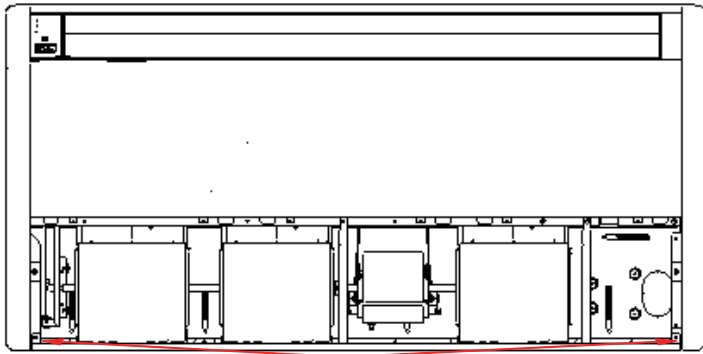
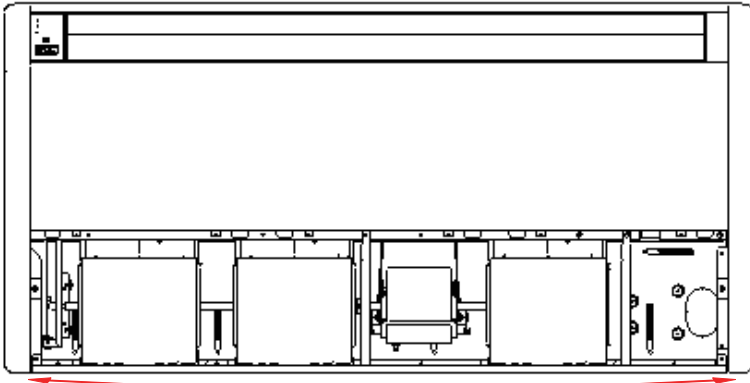
Remove panel grating module		
Remark: Make sure that the power supply is cut off before disassembling and protect all the parts during disassembly. Do not put filter screen near the high temperature heat source.		
Step	Illustration	Handling Instruction
Remove sub-assy of front grill		Move down the clip of the sub-assy of front grill until the front grill is open. (As is shown in the graph, arrow represents the position of buttons. There are two clips for each grating.)
Remove right and left finishing plates		
Remark: Make sure the power supply is cut off before disassembling and protect all the parts during disassembly. Do not scratch the outer parts.		
Step	Illustration	Handling Instruction
Remove right and left finishing plates		<ul style="list-style-type: none"> Remove the screws as shown in the graph with screwdriver and then push upward to remove the right and left finishing plates.(As is shown in the graph, arrow represents the position of screws.)
Remove right and left finishing plates		<ul style="list-style-type: none"> Remove the screws as shown in the graph with screwdriver and then push upward to remove the right and left finishing plates.(As is shown in the graph, arrow represents the position of screws.)

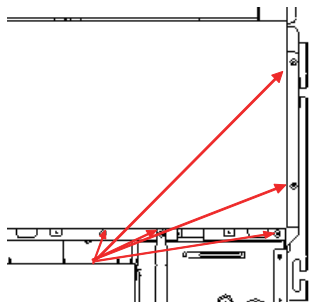
Remove panel parts		
Remark: Make sure the power supply is cut off before disassembling and protect all the parts during disassembly. Do not scratch the outer parts.		
Step	Illustration	Handling Instruction
Remove panel parts		<ul style="list-style-type: none"> Remove the screws shown by the arrow in the graph with screwdriver (two on both right and left and 4 in the front) and then remove the panel parts.

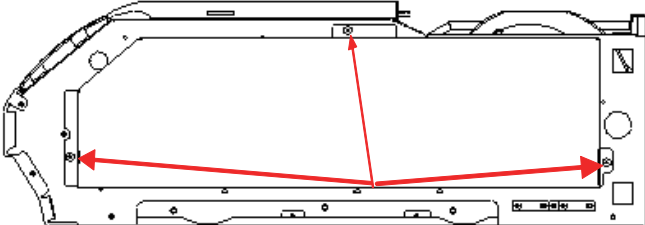
Remove sub-assy of electric box		
Remark: Make sure that the power supply is cut off before disassembling and protect all the parts during disassembly, especially the components inside the box in case of water and hit.		
Step	Illustration	Handling Instruction
1. Remove electric box cover		<ul style="list-style-type: none"> Remove 3 screws as shown by the arrow in the graph on left and remove the electric box cover.

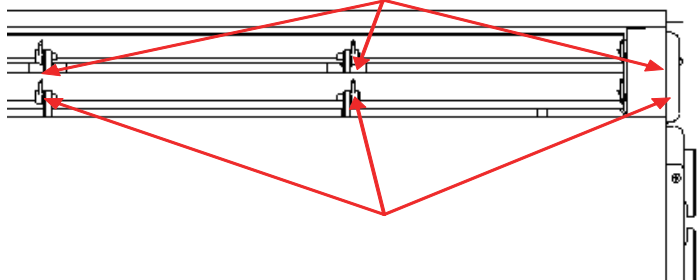
Remove air deflecting plate modules.		
Remark: Make sure the power supply is cut off before disassembling and protect all the parts during disassembly, especially the joints of the air deflecting plate.		
Step	Illustration	Handling Instruction
Remove sub-assy of air deflecting plate		<ul style="list-style-type: none"> Remove the air deflecting plates from the air deflecting plate support assembly, and then remove both ends from the air sweeping motor joint. (As is shown in the graph, arrow represents the support assembly and circle the air sweeping motor joint.)

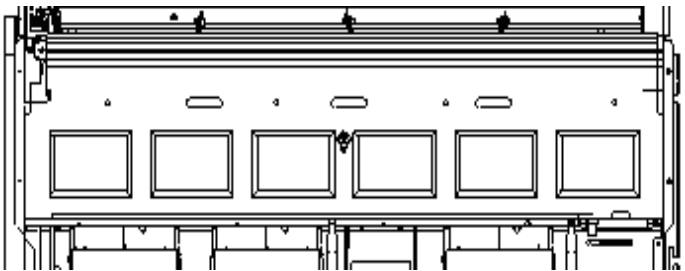
Remove water-containing plate modules		
Remark: Make sure the power supply is cut off before disassembling and protect all the parts during disassembly.		
Step	Illustration	Handling Instruction
Remove water-containing plate modules		<ul style="list-style-type: none"> Remove the water-containing plate modules.

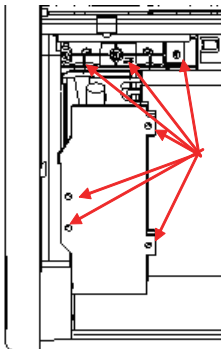
Remove evaporator components		
Remark: Make sure that the power supply is cut off and protect the copper tube and aluminum fin. If the time for disassembly shall be long, seal the copper tube.		
Step	Illustration	Handling Instruction
Remove evaporator components		<ul style="list-style-type: none"> Remove the screws as shown by the arrow in the graph with screwdriver. (There are 6 screws on left and right of the evaporator and 5 on evaporator outlet press plate modules)

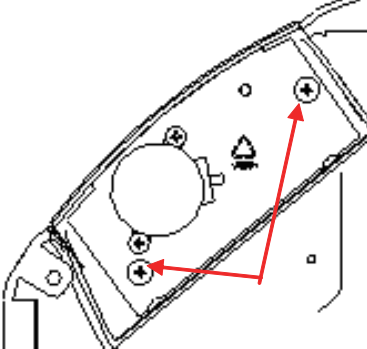
Remove fixing plate sub-assy for air sweeping fans		
Remark: Make sure that the power supply is cut off before disassembling and protect all the parts during disassembly.		
Remark: Make sure that the power supply is cut off before disassembling and protect all the parts during disassembly.		
Step	Illustration	Handling Instruction
Remove fixing plate sub-assy for air sweeping fans		<ul style="list-style-type: none"> Remove the screws shown in the graph with screwdriver.

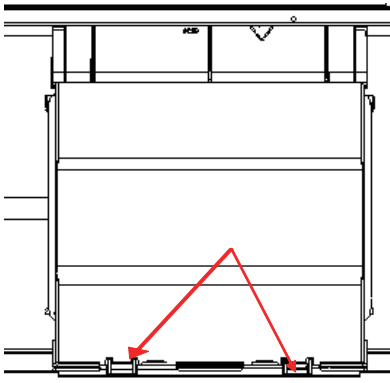
Remove fan and motor components		
Remark: Make sure that the power supply is cut off before disassembling and protect all the parts during disassembly, especially the fastening screws for fans.		
Step	Illustration	Handling Instruction
1. Remove front and back scroll cases		<ul style="list-style-type: none"> Press the buckle at the joints of front and back scroll cases with hands and pull upward to remove the front scroll case. Then remove the screws on the back scroll case. Lift the buckle of back scroll case with hands and remove it. (As is shown in the graph, circle represents 2 screws on left and right.)

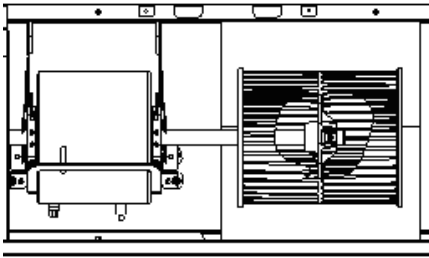
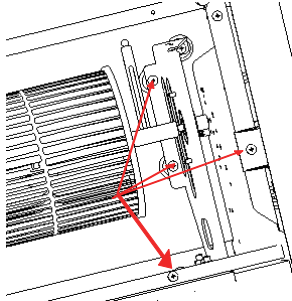
<p>2. Remove fans</p>		<ul style="list-style-type: none"> ● Remove the fixing screws of fan wheel with inner hexagonal and remove the wheel. The inner hexagonal and its direction of effect are shown by the arrow in the graph.
<p>3. Remove bearing fixing plates</p>		<ul style="list-style-type: none"> ● Remove 4 screws on the bearing fixing plates with screwdriver. (As shown in the box in the graph)

Model:GTH48K3CI/GTH60K3CI

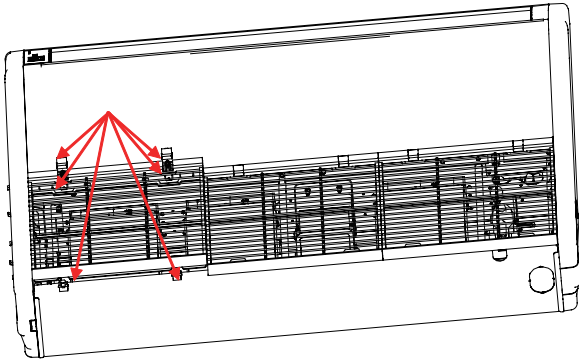
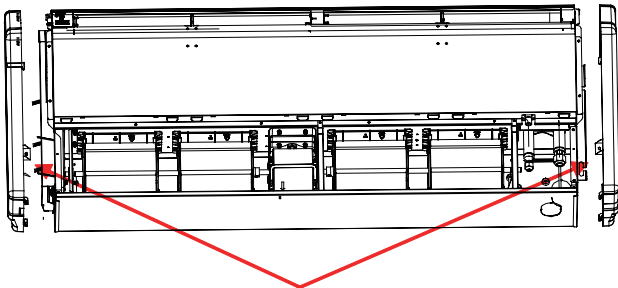
<p>Disassembly of panel grating module</p>		
<p>Remark: Make sure that the power supply is cut off before disassembling and protect all the parts during disassembly. Do not put filter screen near the high temperature heat source.</p>		
<p>Step</p>	<p>Illustration</p>	<p>Handling Instruction</p>
<p>Disassembly of sub-assy of front grill</p>		<ul style="list-style-type: none"> ● Unscrew the 2 clasps of the upper grill and the 2 screws of the clasps. ● Open the grill, disassemble the 2 down clasps to remove the grill
<p>Disassembly of right and left finishing plates</p>		
<p>Remark: Make sure the power supply is cut off before disassembling and protect all the parts during disassembly. Do not scratch the outer parts.</p>		
<p>Step</p>	<p>Illustration</p>	<p>Handling Instruction</p>
<p>Disassembly of right and left finishing plates</p>		<ul style="list-style-type: none"> ● Disassemble the screws as shown in the graph with screwdriver and then push upward to remove the right and left finishing plates.(As is shown in the graph, arrow represents the position of screws.)
<p>Disassembly of panel parts</p>		
<p>Remark: Make sure the power supply is cut off before disassembling and protect all the parts during disassembly. Do not scratch the outer parts.</p>		

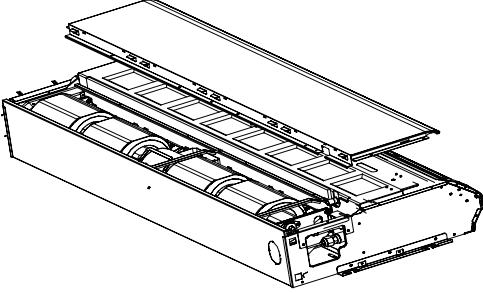
Step	Illustration	Handling Instruction
Disassembly of panel parts		<ul style="list-style-type: none"> •Unscrew the 3 sides' screws on the cover to remove the cover.

Disassembly of sub-assy of electric box

Remark: Make sure that the power supply is cut off before disassembling and protect all the parts during disassembly, especially the components inside the box in case of water and hit.

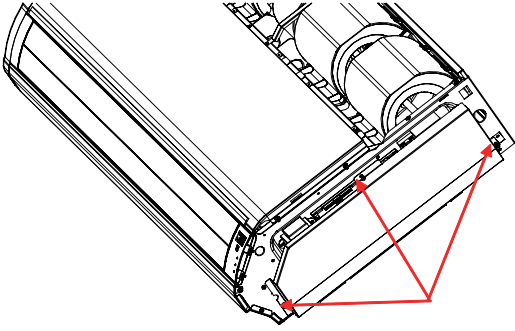
Step	Illustration	Handling Instruction
1. Disassembly of electric box cover		<ul style="list-style-type: none"> •Disassemble 3 screws as shown by the arrow in the graph on left and remove the electric box cover.

Disassembly of air deflecting plate modules

Remark: Make sure the power supply is cut off before disassembling and protect all the parts during disassembly, especially the joints of the air deflecting plate.

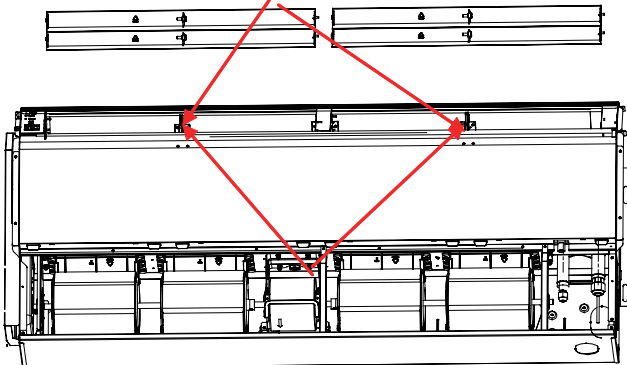
Step	Illustration	Handling Instruction
Disassembly of sub-assy of air deflecting plate		<ul style="list-style-type: none"> •Remove the air deflecting plates from the air deflecting plate support assembly, and then remove both ends from the air sweeping motor joint. (As is shown in the graph, arrow represents the support assembly and circle the air sweeping motor joint.)

Disassemble of water-containing plate modules

Remark: Make sure the power supply is cut off before disassembling and protect all the parts during disassembly.

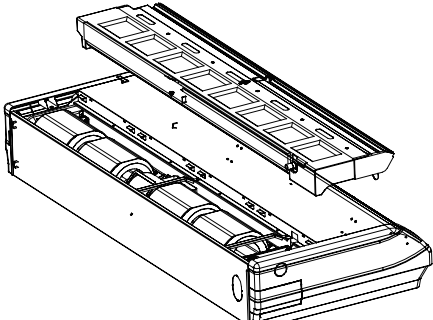
Step	Illustration	Handling Instruction
Disassemble of water-containing plate modules		<ul style="list-style-type: none"> •remove the water-containing plate modules.

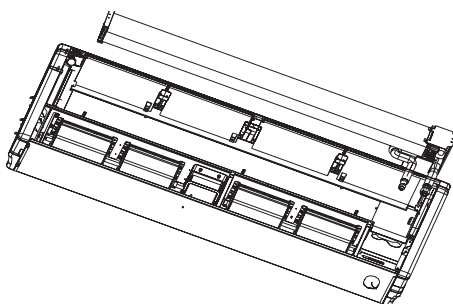
Disassembly of evaporator components		
Remark: Make sure that the power supply is cut off and protect the copper tube and aluminum fin. If the time for disassembly shall be long, seal the copper tube .		
Step	Illustration	Handling Instruction
Disassembly of evaporator components		<ul style="list-style-type: none"> •Unscrew the 6 screws of evaporator, 3 screws of water groove press board and the 2 screws of water board to remove the evaporator.

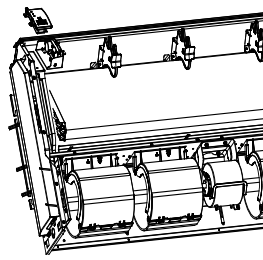
Disassembly of fixing plate sub-assy for air sweeping fans		
Remark: Make sure that the power supply is cut off before disassembling and protect all the parts during disassembly.		
Step	Illustration	Handling Instruction
Disassembly of fixing plate sub-assy for air sweeping fans		<ul style="list-style-type: none"> •Remove the display board, mounting support and mounting plate of swing motor in turn.

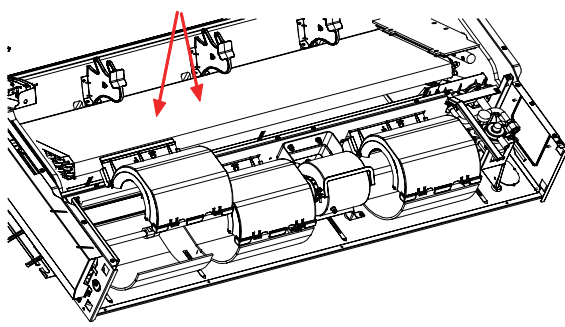
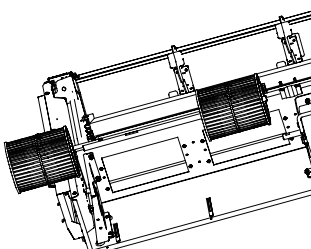
Disassembly of fan and motor components		
Remark: Make sure that the power supply is cut off before disassembling and protect all the parts during disassembly, especially the fastening screws for fans.		
Step	Illustration	Handling Instruction
1. Disassembly of front and back scroll cases		<ul style="list-style-type: none"> •Press the buckle at the joints of front and back scroll cases with hands and pull upward to remove the front scroll case. Then remove the screws on the back scroll case. Lift the buckle of back scroll case with hands and remove it.(As is shown in the graph, circle represents 2 screws on left and right.)
2. Disassembly of fans		<ul style="list-style-type: none"> •Unscrew the 2 screws of coupling, take out the rotating shaft and louver, then loosen the tighten screw of louver to remove the louver.

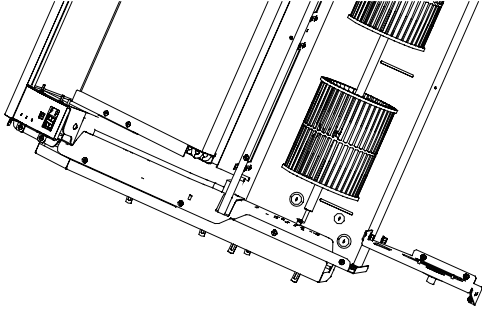
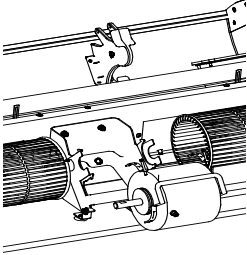
Step	Illustration	Handling Instruction
3. Disassembly of bearing fixing plates		<ul style="list-style-type: none"> • Unscrew the 3 screws and 2 nuts of support to remove the mounting support
4. Disassembly of motor		<ul style="list-style-type: none"> • Loosen the 2 screws of the motor attaching clamp, remove the motor attaching clamp and motor attaching clamp subassembly to remove the motor.

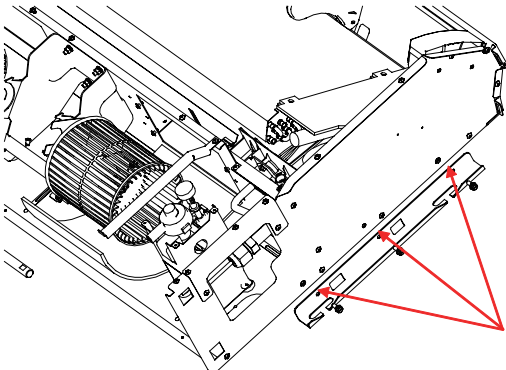
Disassembly of right and left fixing plates		
Remark: Make sure that the power supply is cut off before disassembling and protect all the parts during disassembly.		
Step	Illustration	Handling Instruction
Disassembly of right and left fixing plates		<ul style="list-style-type: none"> • Disassemble the bolts on right and left fixing plates with tools. (As is shown by the arrow in the graph.)

5 EXPLODED VIEWS AND SPARE PART LIST

5.1 Outdoor Unit

Model: GUHD09NK3CO/GUHD12NK3CO Exploded Views and spare parts list:

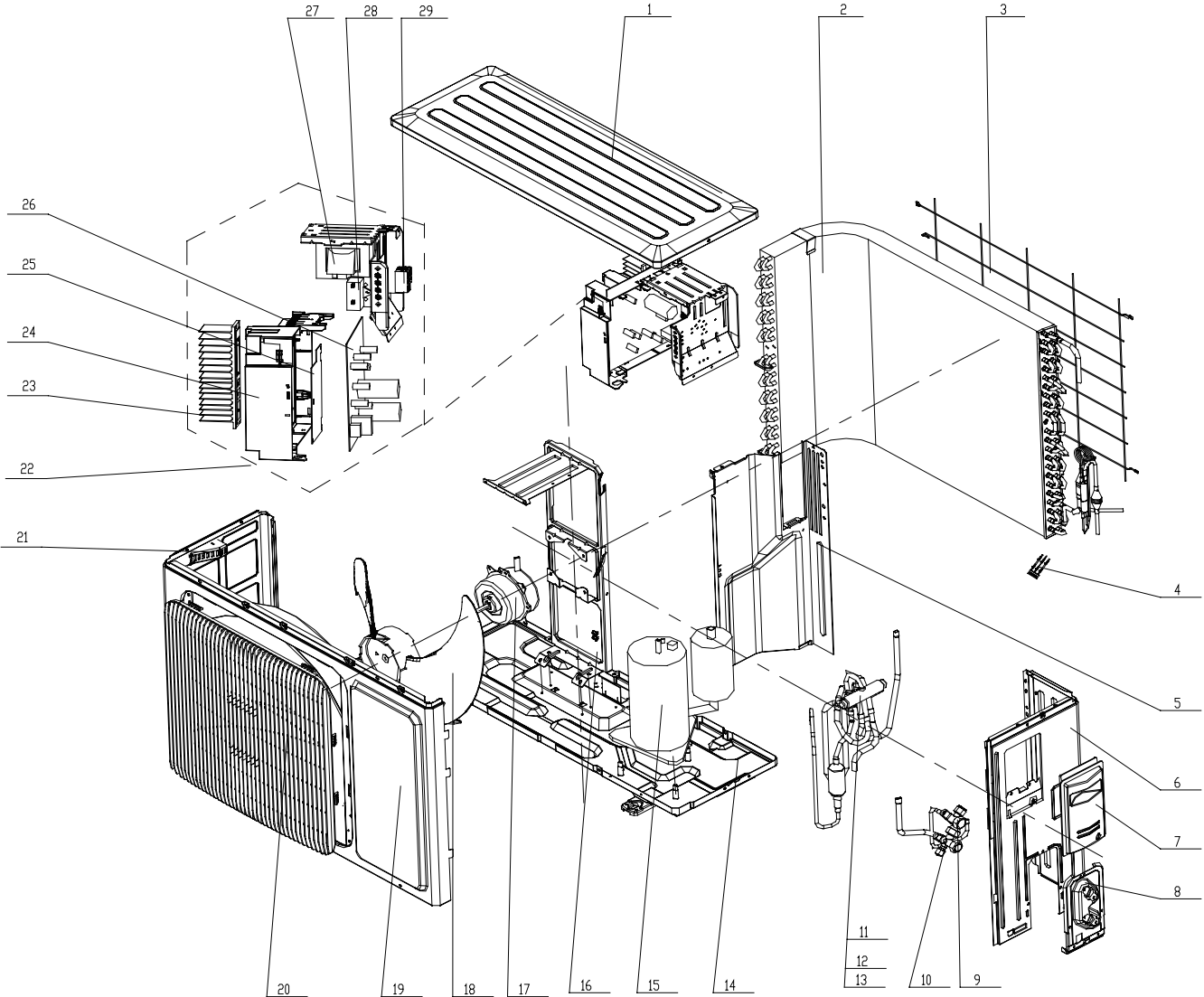

NO.	Description	GUHD09NK3CO	GUHD12NK3CO	Qty
		CF090W0260	CF090W0270	
	Name of Part	Part Code	Part Code	
1	Top Cover Sub-Assy	01253454	01253454	1
2	Condenser Assy	01125387	01125386	1
3	Rear Grill	01473042	01473042	1
4	Temperature Sensor	3900028008	3900028008	1
5	Clapboard Sub-Assy	01233385	01233385	1
6	Right Side Plate Sub-Assy	0130317801	0130317801	1
7	Big Handle	26233433	26233433	1
8	Valve Support	01703089P	01703089P	1
9	Cut-off Valve	07130239	07130239	1
10	Valve	07100005	07100005	1
11	Magnet Coil	4300040050	4300040050	1
12	4-way Valve	430004022	430004022	1
13	4-way Valve Assy	03123385	03123385	1
14	Chassis Sub-assy	01203912P	01203912P	1
15	Compressor and fittings	00103209	00103209	1

16	Motor Support	01703058	01703058	1
17	Fan Motor	1501306713	1501306713	1
18	Axial Flow Fan	10333004	10333004	1
19	Front Panel	01533027P	01533027P	1
20	Front grill	22413433	22413433	1
21	Small Handle	'26233100	'26233100	1
22	Electric Box Assy	01395860	01395860	1
23	Radiator	49013027	49013027	1
24	Electric Box	20113014	20113014	1
25	Filter Board	30033073	30033073	1
26	Main Board	30228206	30228207	1
27	Reactor	43130184	43130184	1
28	Capacitor	'33010026	'33010026	1
29	Terminal Board	42011154	42011154	1

Model: GUHD09NK3C10/GUHD12NK3C10 Exploded View and spare parts list:

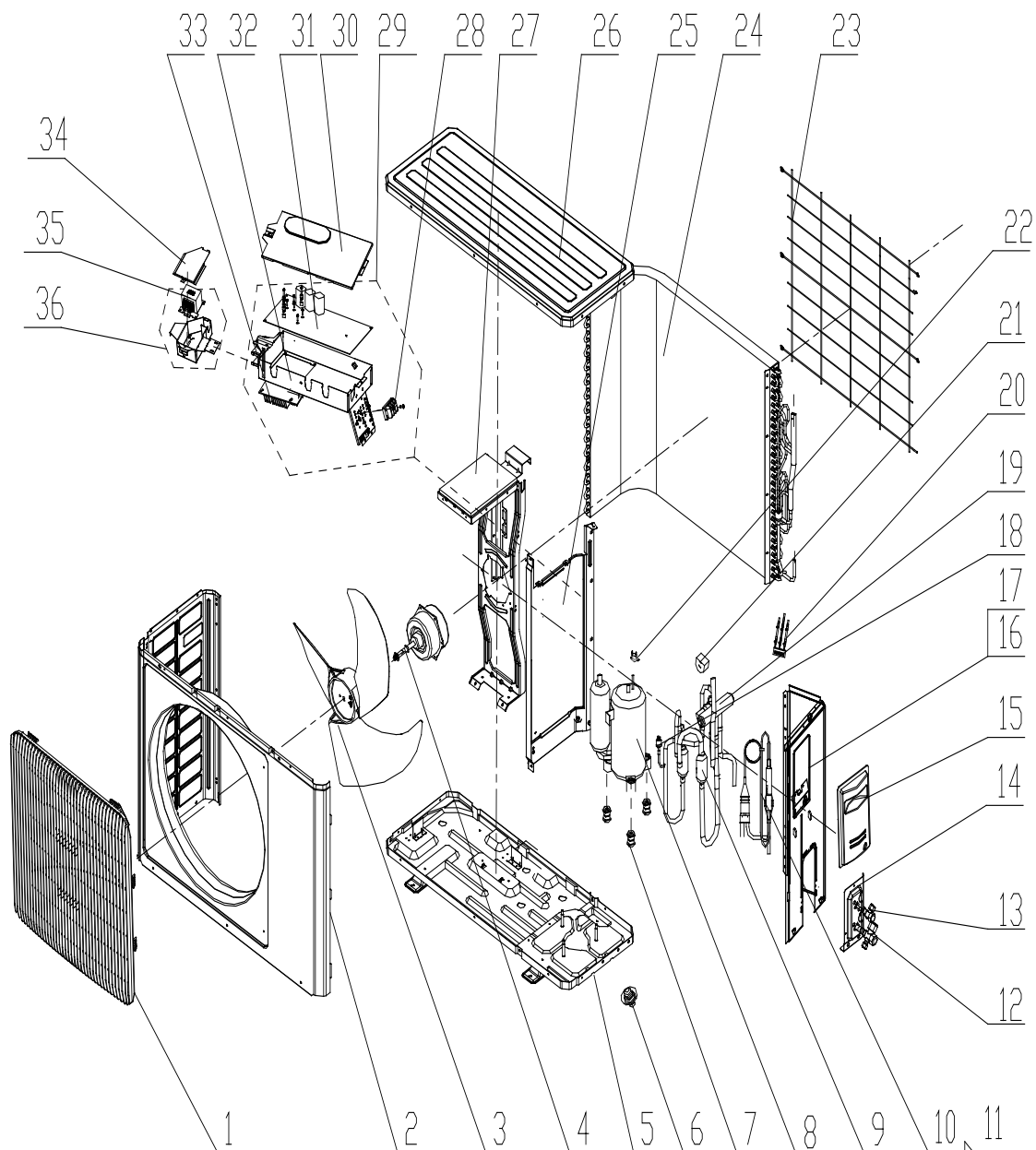

NO.	Description	GUHD09NK3C10	GUHD12NK3C10	Qty
		CF090W0340	CF090W0350	
	Name of Part	Part Code	Part Code	
1	Front Grill	22413433	22413433	1
2	Front Panel	22413433	015330124	1
3	Axial Flow Fan	015330124	10333012	1
4	Fan Motor	10333012	15013159	1
5	Chassis Sub-assy	15013159	01195320P	1
6	Drainage Connector	01195320P	06123401	1
7	Compressor Gasket	06123401	76711040	3
8	Compressor and Fittings	76711040	00103209	1
9	Silencer	00103209	07245007	1
10	StrainerA	07245007	07210022	1
11	Capillary Sub-Assy	07210022	04105736	1
12	Cut off Valve	07133082	07133082	1
13	Valve	07100005	07100005	1
14	Valve Support	01713041	01713041	1
15	Big Handle	26233433	26233433	1
16	Right Side Plate Assy	0130200404	0130200404	1
17	Right Side Plate	0130304802	0130304802	1
18	Pressure Protect Switch	46020003	46020003	1
19	4-Way Valve	430004022	430004022	1
20	Temperature Sensor	39000310	39000310	1
21	Magnet Coil	4300040047	4300040047	1
22	Overload Protector	00180030	00180030	1
23	Rear Grill	01473057	01473057	1
24	Condenser Assy	01125423	01125422	1
25	Clapboard Sub-Assy	01233034	01233034	1
26	Top Cover Plate	01253443	01253443	1
27	Motor Support Sub-Assy	01703101	01703101	1
28	Terminal Board	42011154	42011154	1
29	Electric Box Assy	02405235	02405235	1
30	Electric Box Cover Sub-Assy	0260309601	0260309601	1
31	Main Board	30228209	30228209	1
32	Electric Box 1	20113005	20113005	1
33	Radiator	49010252	49010252	2
34	Cover of Reactor Box	01413029	01413029	1
35	Reactor	43130185	43130185	1
36	Reactor Sub-assy	01403616	01403616	1

Model: GUHD18NK3CO Exploded View and spare parts list:

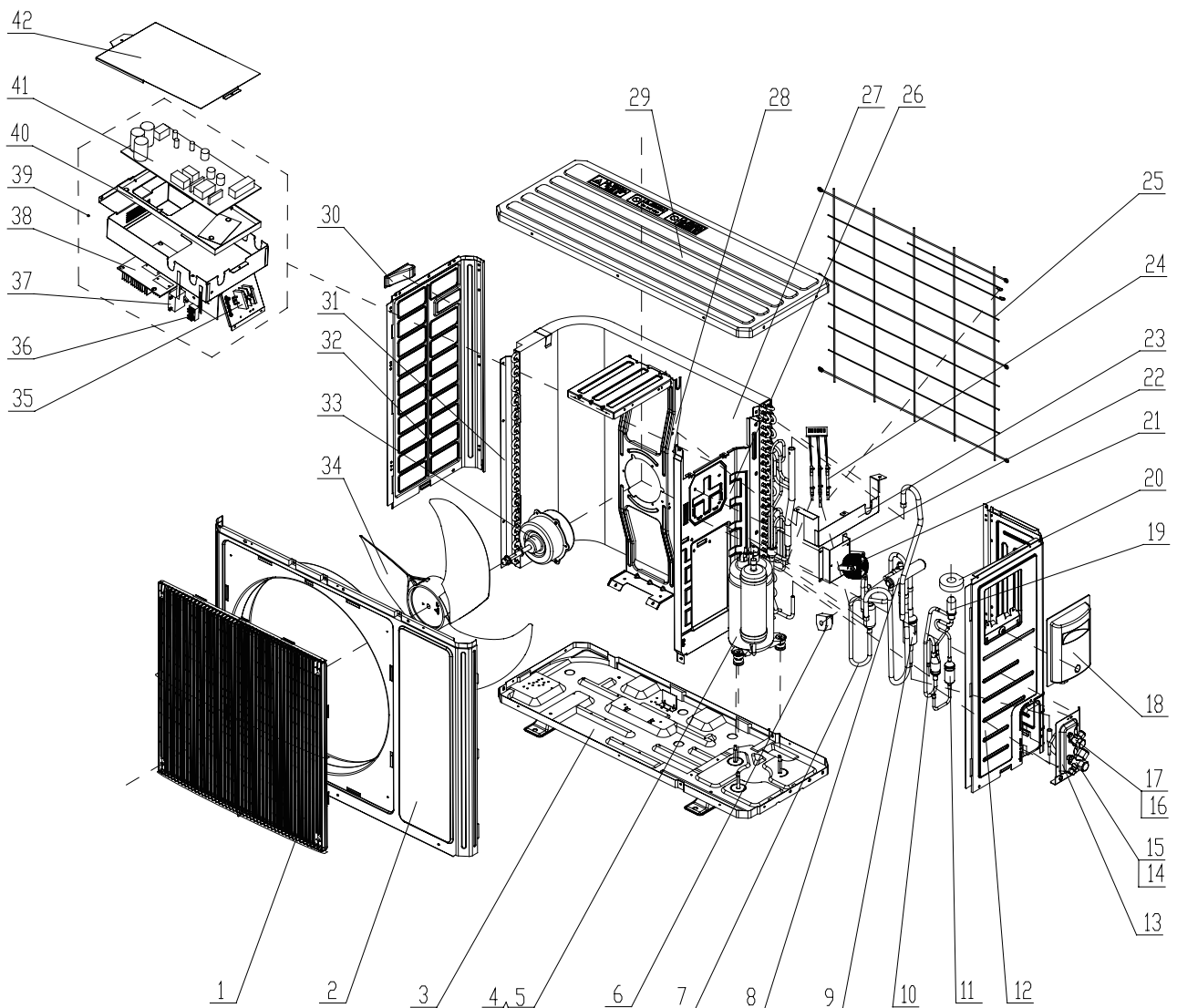

NO.	Dscription	GUHD18NK3CO	Qty
		CF090W0281	
		Name of Part Part Code	
1	Front Grill	'22415002	1
2	Front Panel	'01535008P	1
3	Chassis Sub-Assy	'0120371401P	1
4	Compressor And Fittings	'00103501	1
5	Compressor Gasket	'76710236	3
6	Magnet Coil	'4300040033	1
7	4-way Valve Assy	'04145373	1
8	4-way Valve	'430004032	1
9	Gas Tube Filter	'072190511	1
10	Electronic Expansion Valve Assy	'07335277	1
11	Strainer	'07220019	1
12	Right Side Plate	'01305053P	1
13	Valve Support Assy	'01715010P	1
14	Cut-off Valve Sub-Assy	'07133060	1

15	Cut-off Valve	'071302392	1
16	Cut-off Valve Sub-Assy	'07133058	1
17	Cut-off Valve	'07130239	1
18	Handle	'26235254	1
19	Electronic Expansion Valve	'07134601	1
20	Electric expand valve fitting	'4300876703	1
21	Inductance	'4312002001	1
22	Supporter	'01805405	1
23	Supporting Strip	'01895240	1
24	Temperature Sensor	'3900028010	1
25	Rear Grill	'01473043	1
26	Clapboard Sub-Assy	'01232902	1
27	Condenser Assy	'01113386	1
28	Motor Support Sub-Assy	'01705020	1
29	Top Cover	'01255005P	1
30	Left Handle	'26235401	1
31	Supporting board	01795010	1
32	Left Side Plate	'01305041P	1
33	Fan Motor	'1501506104	1
34	Axial Flow Fan	'10335008	1
35	Terminal Board	'420111451	1
36	Terminal Board	'42011103	1
37	Capacitor CBB61	'33010010	1
38	Radiator	49018114	1
39	Electric Box Assy	'01395861	1
40	Electric Box 1	'20113001	1
41	Main Board	'30224308	1
42	Electric Box Cover	01425333	1

Model: GUHD18NK3C1O Exploded View and spare parts list:

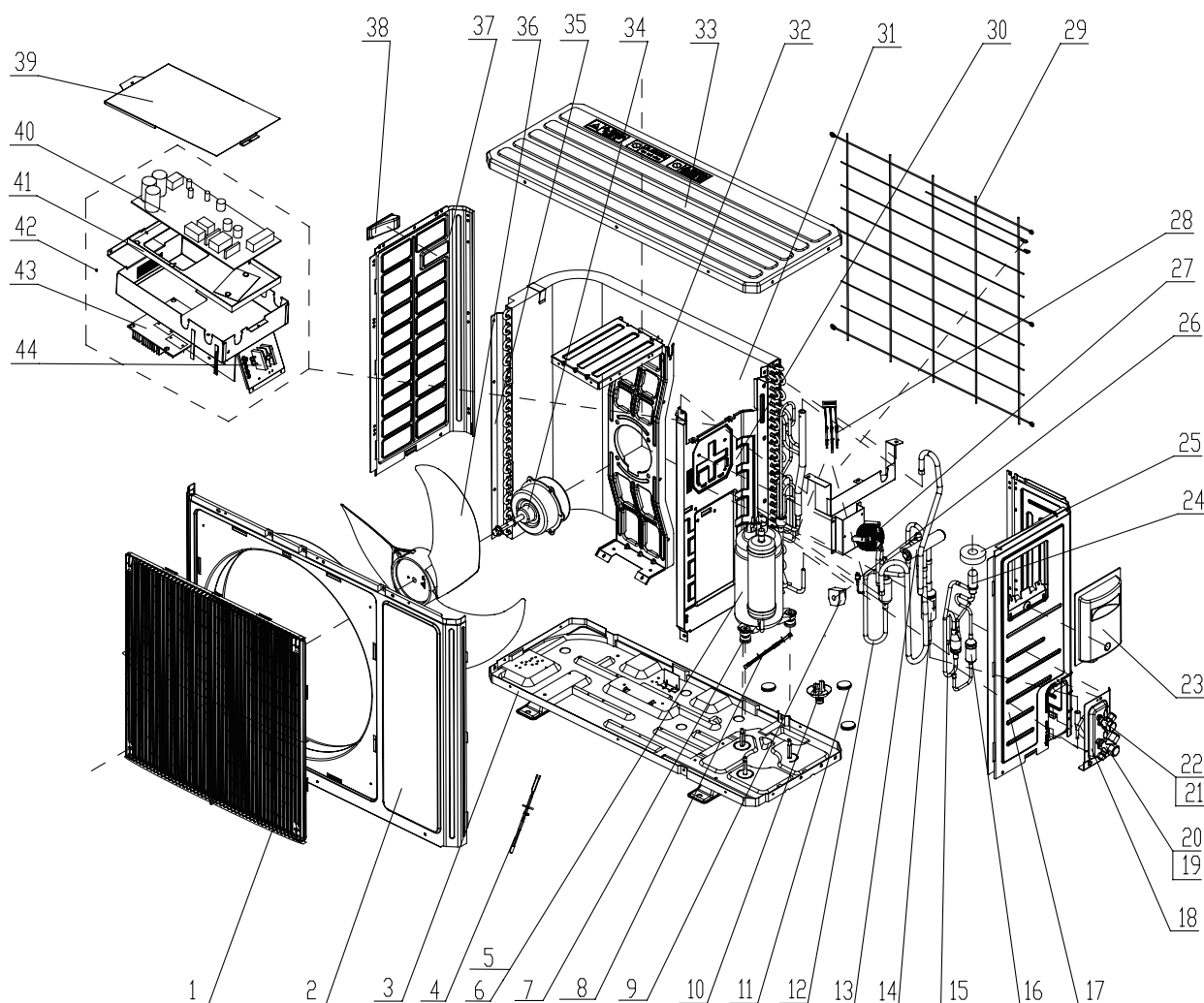

NO.	Description	GUHD18NK3C1O	
		CF090W0500	Qty
		Name of Part	
1	Front Grill	'22415002	1
2	Front Panel	'01535008P	1
3	Chassis Assy	'01195709	1
4	Electrical Heater	'765100047	1
5	Compressor and Fittings	'00103501	1
6	Overload Protector	'00180002	1
7	Rubber Grommet	'76710236	3
8	Electric Heater(Compressor)	'7651300402	1
9	Magnet Coil	'4300040033	1
10	Drainage Connector	'06123401	1
11	Drainage Plug	'06813401	3
12	4-Way Valve Assy	'04145730	1
13	4-Way Valve	'430004032	1
14	Gas Tube Filter	'072190511	1
15	Electronic Expansion Valve assy	'07335277	1
16	Strainer	'0721004501	1

17	Right Side Plate	'01305053P	1
18	Valve support assy	'01715010P	1
19	Cut off Valve Sub-Assy	'07133060	1
20	Cut off Valve	'071302392	1
21	Cut off Valve Sub-Assy	'07133058	1
22	Cut off Valve	'07130239	1
23	Handle	'26235254	1
24	Electronic Expansion Valve	'07134601	1
25	Electric expand valve fitting	'4300876703	1
26	Pressure Protect Switch	'46020003	1
27	Inductance	'4312002001	1
28	Temperature Sensor	'3900028010G	1
29	Rear Grill	'01473043	1
30	Clapboard Sub-Assy	'01232902	1
31	Condenser Assy	'01113386	1
32	Motor Support Assy	'01805455	1
33	Top Cover	'01255005P	1
34	Fan Motor	'1570411502	1
35	Supporting Board(Condenser)	'01795010	1
36	Axial Flow Fan	'10335008	1
37	Left Side Plate	'01305041P	1
38	Left Handle	'26235401	1
39	Electric Box Cover	'01425333	1
40	Main Board	'30224073	1
41	Electric Box 1	'20113001	1
42	Electric Box Assy	'02405228	1
43	Radiator	'49018114	1
44	Terminal Board	'420111451	1

Model: GUHD24NK3CO Exploded View and spare parts list.

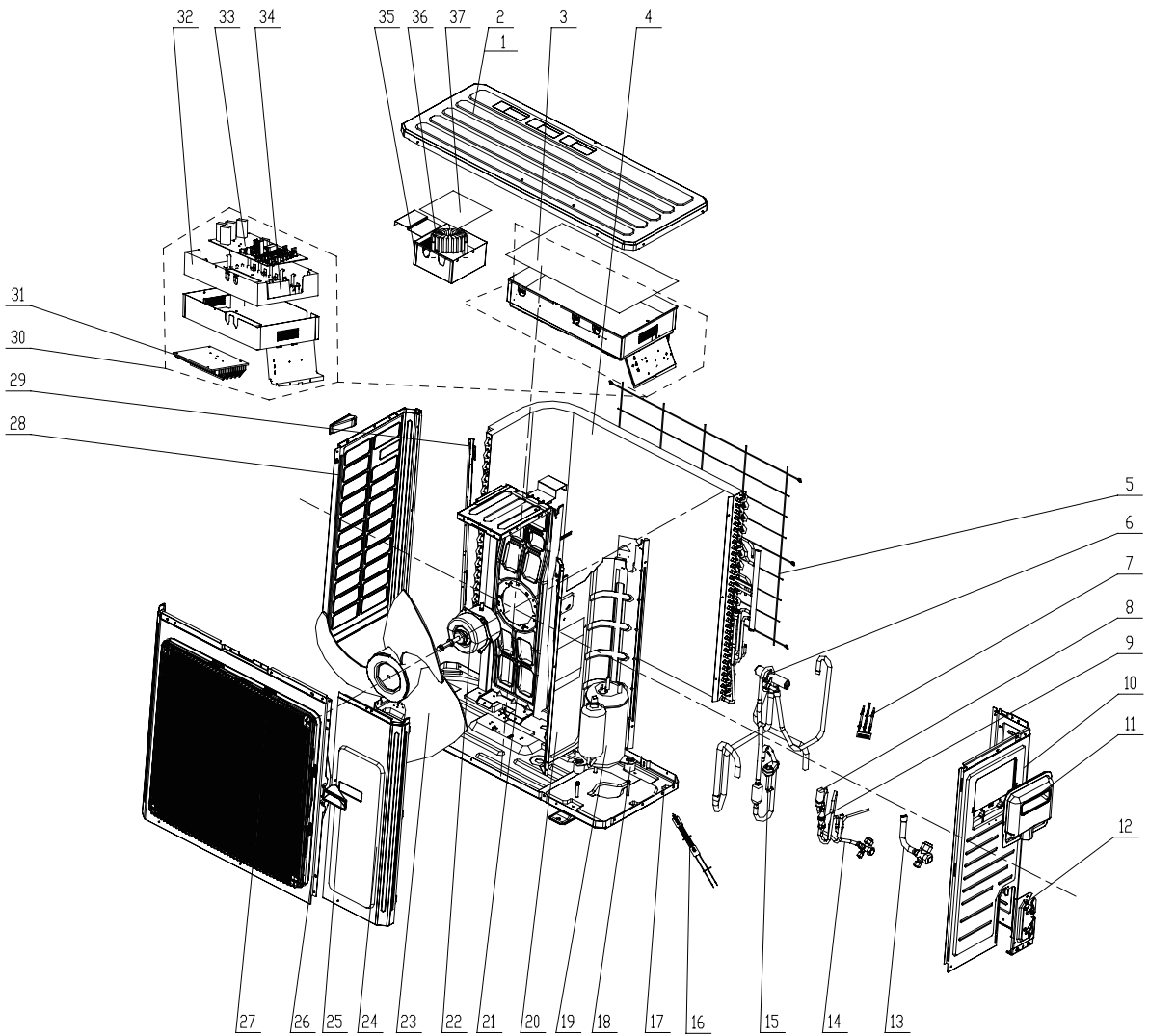

NO.	Description Name of Part	GUHD24NK3CO	Qty
		CF090W0290	
		Part Code	
1	Top Cover	'01255006P	1
2	Top Cover Sub-Assy	'01255007	1
3	Electric Box Cover	'01425281	1
4	Condenser Assy	'01125394	1
5	Rear Grill	'01475008	1
6	4-way Valve	'4300008201	1
7	Temperature Sensor	'3900028010	1
8	Electronic Expansion Valve	'07334193	1
9	StrainerA	'07210022	2
10	Right Side Plate	'01305044P	1
11	Big Handle	'26235001	1
12	Valve Support Sub-Assy	'01715012P	1
13	Cut-off Valve	'07133157	1
14	Valve	'07100005	1
15	Pressure Protect Switch	'460200061	1
16	electrical heater	'76518732	1

17	Chassis Sub-assy	'01195307P	1
18	Compressor Gasket	'76710207	3
19	Compressor and fittings	'00105036	1
20	Clapboard	'01245237	1
21	Motor Support Sub-Assy	'01805362	1
22	Fan Motor	'15705224	1
23	Axial Flow Fan	'10335005	1
24	Front Side Plate	'01305072P	1
25	left handle	'26235401	2
26	Cabinet	'01435004P	1
27	Front Grill	'22415003	1
28	Left Side Plate	'01305043P	1
29	Condenser support plate	'01175092	1
30	Electric Box Assy	'01395898	1
31	Radiator	'49018112	1
32	Electric Box	'26905211	1
33	Main Board	'30224306	1
34	Capacitor CBB61	'33010009	1
35	Electric Box Sub-Assy	'01395787	1
36	PFC Inductance	'43128003	1
37	Electric Box Cover	'01425279	1

Model: GUHD30NK3CO Exploded View and spare parts list:

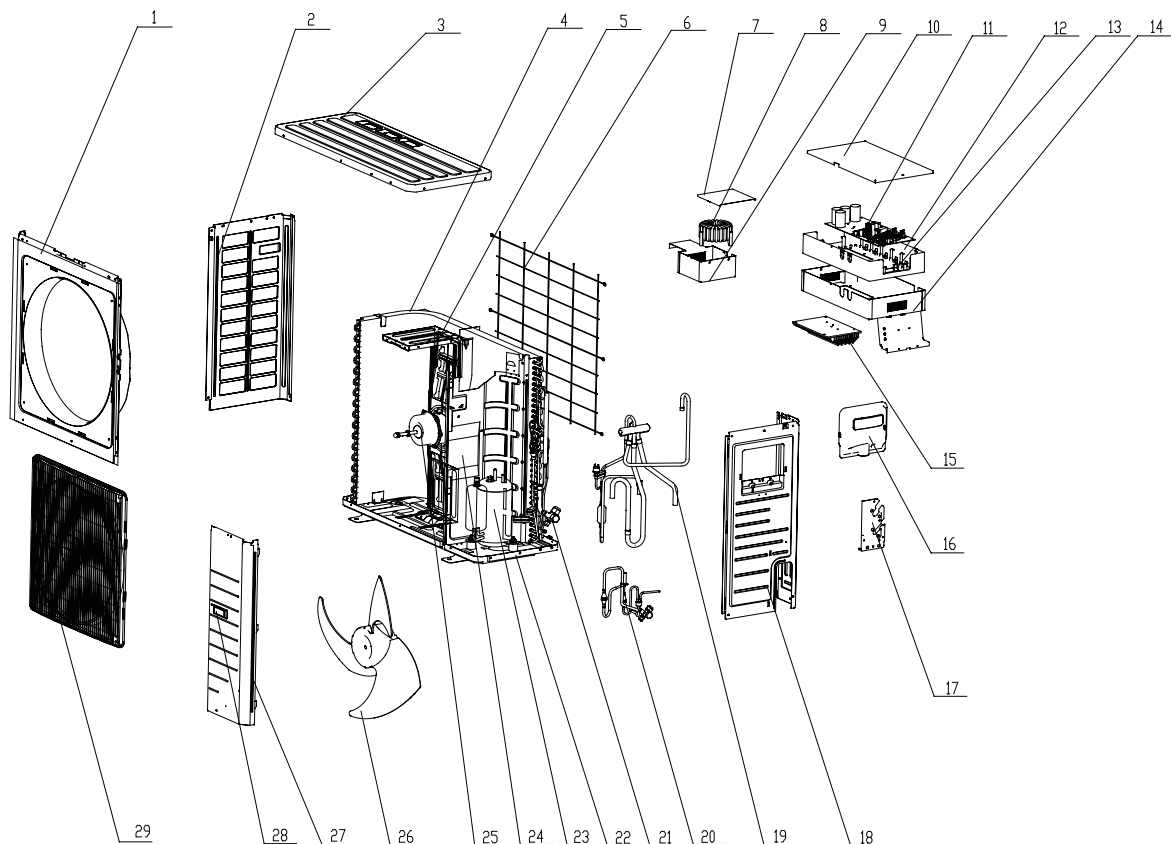

NO.	Description	GUHD30NK3CO	Qty
		CF090W0290	
	Name of Part	Part Code	
1	Cabinet	'01435004P	1
2	Left Side Plate	'01305043P	1
3	Top Cover Sub-Assy	'01255007	1
4	Condenser Assy	'01125396	1
5	Motor Support Sub-Assy	01805429	1
6	Rear Grill	'01475008	1
7	Electric Box Cover	'01425279	1
8	PFC Inductance	'43128003	1
9	Inductance Box Assy	01395909	1
10	Electric Box Cover	'01425281	1
11	Main Board	'30224306	1
12	Electric Box	'26905211	1
13	Capacitor CBB61	'33010009	1
14	Electric Box Sub-Assy	01395991	1
15	Radiator	'49018112	1
16	Big Handle	'26235001	1
17	Valve Support Sub-Assy	'01715012P	1
18	Right Side Plate	'01305044P	1
19	4-way Valve Assy	'04145366	1
20	Electric Expansion Valve Sub-Assy	07335274	1
21	Cut-off Valve	'07133157	1
22	Chassis Sub-assy	01195311P	1
23	Compressor and fittings	'00105036	1
24	Clapboard	01245254	1
25	Fan Motor	'15705224	1
26	Axial Flow Fan	'10335005	1
27	Front Side Plate	'01305072P	1
28	left handle	'26235401	2

Model: GUHD24NK3C10\GUHD30NK3C10 Exploded View and spare parts list

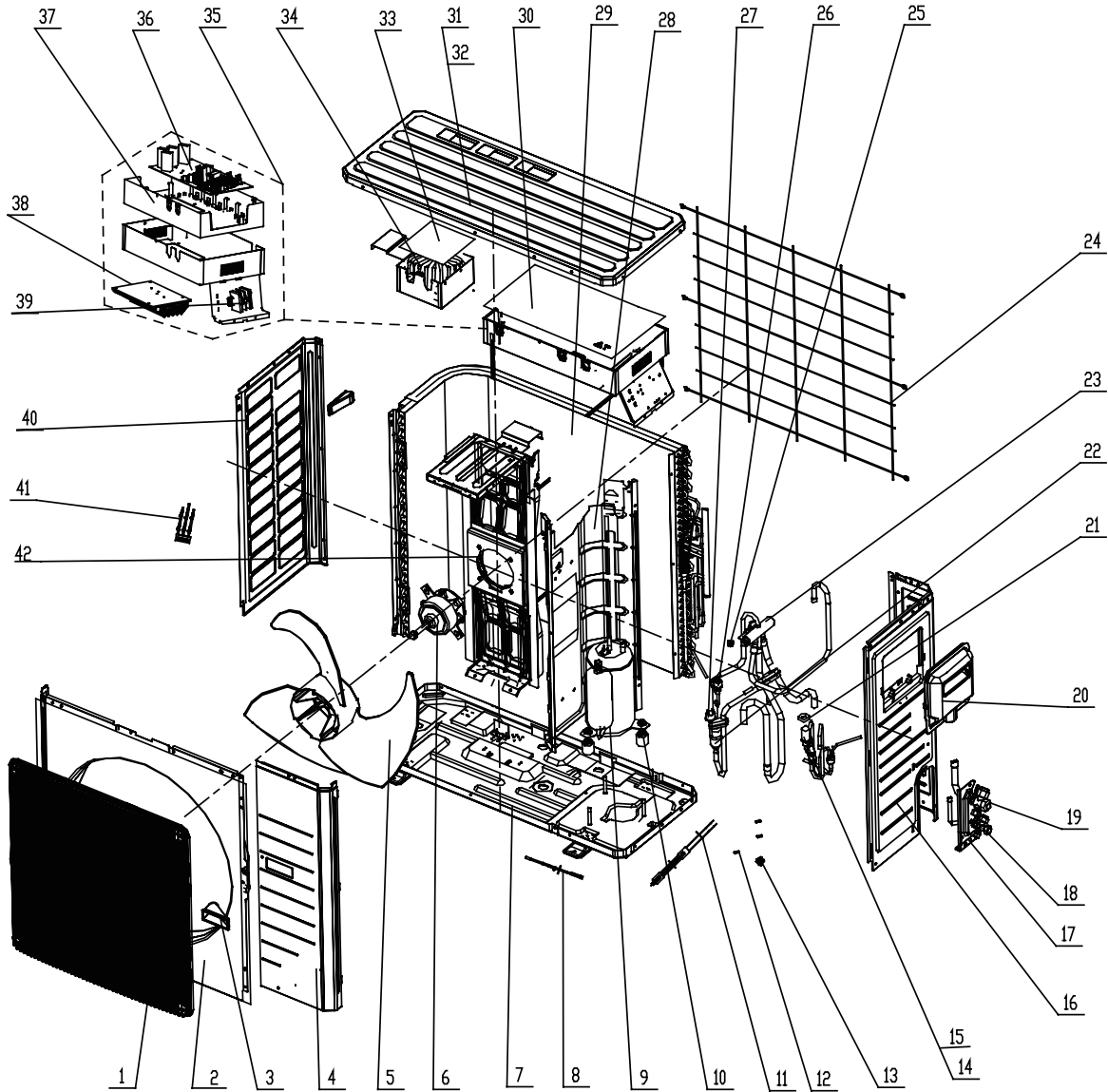

NO.	Description	GUHD24NK3C10	GUHD30NK3C10	Qty
		CF090W0510	CF090W0520	
	Name of Part	Part Code	Part Code	
1	Front Grill	'22415003	'22415003	1
2	Cabinet	'01435004P	'01435004P	1
3	Left Handle	'26235401	'26235401	2
4	Front Side Plate	01305086P	01305086P	1
5	Axial Flow Fan	10335005	10335005	1
6	Fan Motor	'15702802	'1570280202	1
7	Chassis Sub-assy	01195314P	01195314P	1
8	Electrical Heater	'765100047	'765100047	1
9	Compressor and Fittings	'00105036	'00105036	1
10	Rubber Grommet	'76710207	'76710207	3
11	Electrical heater	'76518732	'76518732	1
12	Drainage Plug	'06813401	'06813401	3
13	Drainage Connector	'06123401	'06123401	1

14	StrainerA	'07210022	'07210022	2
15	Electronic Expansion Valve	'07334193	'07334193	1
16	Right Side Plate	'01305044P	'01305044P	1
17	Valve Support Sub-Assy	'01715012P	'01715012P	1
18	Valve	'07100005	'07100005	1
19	Cut off Valve	'07133157	'07133157	1
20	Big Handle	'26235001	'26235001	1
21	Electric Expand Valve Fitting	4300010818	4300010818	1
22	Silencer	'07245007	'07245007	1
23	4-way Valve	'4300008201	'4300008201	1
24	Rear Grill	'01475008	'01475008	1
25	Magnet Coil	'4300040029	'4300040029	1
26	Pressure Protect Switch	'46020006	'46020006	1
27	Pressure Protect Switch	'46020003	'46020003	1
28	Clapboard	01245237	01245237	1
29	Condenser Assy	01125394	01125396	1
30	Electric Box Cover	'01425281	01425281	1
31	Top Cover	'01255006P	01255006P	1
32	Top Cover Sub-Assy	'01255007	01255007	1
33	Electric Box Cover	'01425279	01425279	1
34	PFC Inductance	'43128003	43128003	1
35	Electric Box Assy	02405227	02405227	1
36	Main Board	30224074	30224074	1
37	Electric Box	26905211	26905211	1
38	Radiator	49018112	49018112	1
39	Terminal Board	420111451	420111451	1
40	Left Side Plate	'01305043P	'01305043P	1
41	Temperature Sensor	3900028016G	3900028016G	1
42	Motor Support Assy	01805452	01805452	1

Model: GUHD36NK3CO/GUHD42NK3CO Exploded View and spare parts list

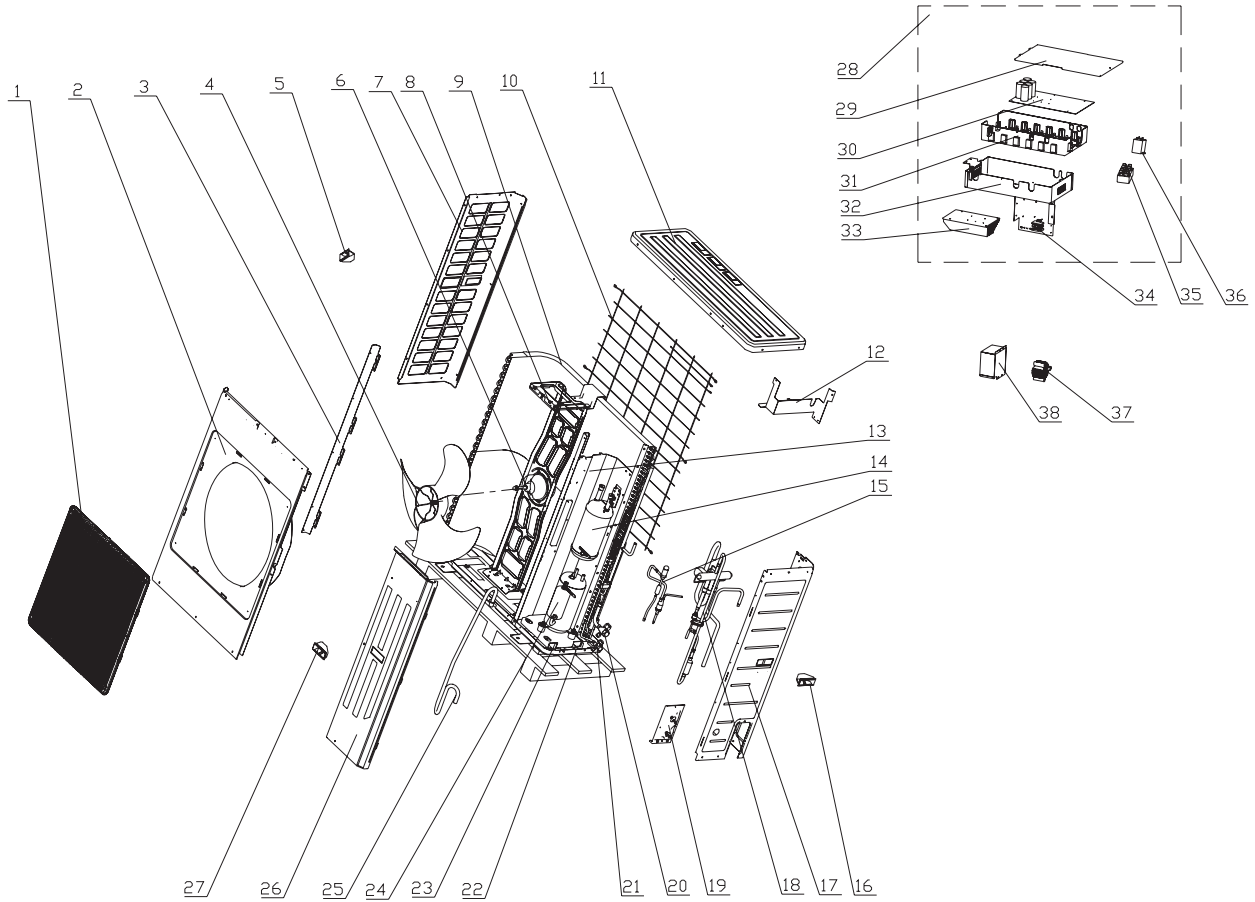

NO.	Description	GUHD36NK3CO		GUHD42NK3CO		Qty
		CF090W0300	CF090W0301	CF090W0310	CF090W0311	
	Name of Part	Part Code	Part Code	Part Code	Part Code	
1	Front Grill	22415005	22415005	22415005	22415005	1
2	Cabinet	01435007P	01435007P	01435007P	01435007P	1
3	Condenser support plate	01895309	01795020	1895309	1895309	1
4	Axial Flow Fan	10335010	10335010	10335010	10335010	1
5	left handle	26235401	26235401	26235401	26235401	1
6	Fan Motor	150154516	150154516	150154516	150154516	1
7	Left Side Plate	01305064P	01305064P	01305064P	01305064P	1
8	Motor Support Sub-Assy	1805396	1805396	1805396	1805396	1
9	Condenser Assy	01125736	01125392	1125392	1125392	1
10	Rear Grill	1475012	1475012	1475012	1475012	1
11	Top Cover	01255009P	01255009P	01255009P	01255009P	1
12	Air Guard	1355204	1355204	1355204	1355204	1
13	Clapboard Sub-assy	1245246	1245246	1245246	1245246	1
14	Gas-liquid Separator Sub-Assy	7255201	7255201	7255201	7255201	1
15	Electric Expansion Valve Sub-Assy	07335263	07335271	7335271	7335271	1
16	Handle	26235253	26235253	26235253	26235253	1
17	Right Side Plate Sub-Assy	01305441P	'01305089P	01305441P	'01305089P	1
18	4-way Valve Assy	04145342	04145748	04145362	04145748	1

19	Valve Support Sub-Assy	01715257P	01715257P	01715257P	01715257P	1
20	Cut-off Valve	'07133157	'07133157	'07133157	'07133157	1
21	Valve	'07133185	'07133185	'07133185	'07133185	1
22	Chassis Sub-assy	01195244P	01195244P	01195244P	01195244P	1
23	Retaining Plate Sub-Assy	01845235P	01845235P	01845235P	01845235P	1
24	Compressor and fittings	00205230	00205275	205230	00205275	1
25	Inhalation Tube	4655520	4655520	4655520	4655520	1
26	Front Side Plate Sub-Assy	1305508	1305508	1305508	1305508	1
27	Handle	26235253	26235253	26235253	26235253	1
28	Electric Box Sub-assy	1395852	1395852	1395852	1395852	1
29	Electric Box Cover	1425326	1425326	1425326	1425326	1
30	Main Board	30224305	30224305	30224305	30224305	1
31	Electric box	1425330	1425330	1425330	1425330	1
32	Electric box-Assy	1395810	1395810	1395810	1395810	1
33	Radiator	49010252	49010252	49010252	49010252	1
34	Terminal Board	42011242	42011242	42011242	42011242	1
35	Terminal Board	42011103	42011103	42011103	42011103	1
36	Capacitor	33010009	33010009	33010009	33010009	1
37	PFC Inductance	43120011	43120011	43120011	43120011	1
38	Electric Box Cover Sub-assy	1425326	1425326	1425326	1425326	1

Model: GUHD36NK3C10/GUHD42NK3C10 Exploded View and spare parts list

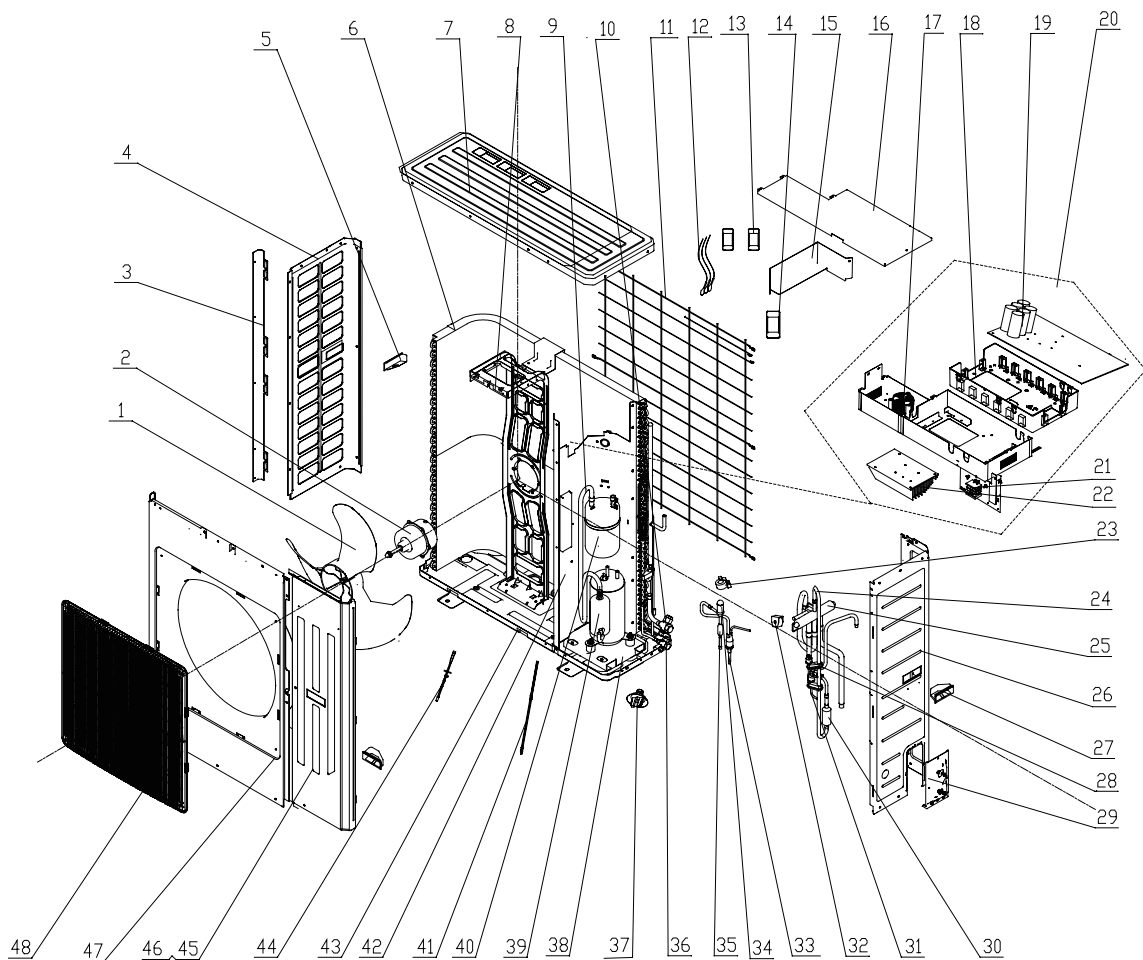

NO.	Description	GUHD36NK3C10	GUHD42NK3C10	Qty
		CF090W0530	CF090W0540	
	Name of Part	Part Code	Part Code	
1	Axial Flow Fan	'10335010	'10335010	1
2	Fan Motor	1570280201	1570280201	1
3	Condenser support plate	'01895309	'01895309	1
4	Left Side Plate	'01305064P	'01305064P	1
5	Left Handle	'26235401	'26235401	1
6	Condenser Assy	01125736	'01125392	1
7	Top Cover	'01255009P	'01255009P	1
8	Motor Support Sub-Assy	'01705111	'01705111	1
9	Inhalation Tube 1	'04655520	'04655520	1
10	Cut off Valve	'07133157	'07133157	1
11	Rear Grill	'01475012	'01475012	1
12	Temperature Sensor	'3900028002G	'3900028002G	1
13	Magnetic Ring	49010104	49010104	2
14	Magnetic Ring	49010109	49010109	1
15	Air Guard	'01355204	'01355204	1
16	Electric Box Cover	'01425326	'01425326	1
17	PFC Inductance	43120011	43120011	1
18	Electric Box	26905211	26905211	1
19	Main Board	30224075	30224075	1
20	Electric Box Assy	02405224	02405224	1
21	Terminal Board	42011242	42011242	1
22	Radiator	49018112	49018112	1
23	Electric expand valve fitting	'4300010822	'4300010822	1
24	4-Way Valve Assy	04145733	04145732	1
25	4-way Valve	'43000338	'43000338	1
26	Right Side Plate Sub-Assy	'01305441P	'01305441P	1
27	Handle	'26235253	'26235253	2
28	Pressure Protect Switch	'46020006	'46020006	1
29	Valve Support Sub-Assy	'01715257P	'01715257P	1
30	Strainer	'07215201	'07215201	1
31	Pressure Protect Switch	'46020003	'46020003	1
32	Magnet Coil	'4300040029	'4300040029	1
33	Electric Expansion Valve Sub-Assy	'07335263	07335271	1
34	Electronic Expansion Valve	'07334194	'07334194	1
35	Strainer	'07210045	'07210045	1
36	Cut off Valve	'071302391	'071302391	1
37	Drainage Joint	'26113009	'26113009	1
38	Retaining Plate Sub-Assy	'01845235P	'01845235P	1
39	Compressor and fittings	'00205275	'00205275	1
40	Gas-liquid Separator Sub-Assy	'07255201	'07255201	1
41	electrical heater	'76518732	'76518732	1
42	Clapboard Sub-Assy	01245261	01245261	1
43	Chassis Sub-assy	01195315P	01195315P	1
44	Electrical Heater	765100047	765100047	1
45	Front Side Plate Sub-Assy	'01305508	'01305508	1
46	Front Side Plate	01305065P	01305065P	1
47	Cabinet	'01435007P	'01435007P	1
48	Front Grill	'22415005	'22415005	1

Model: GUHD48NK3CO Exploded View and spare parts list

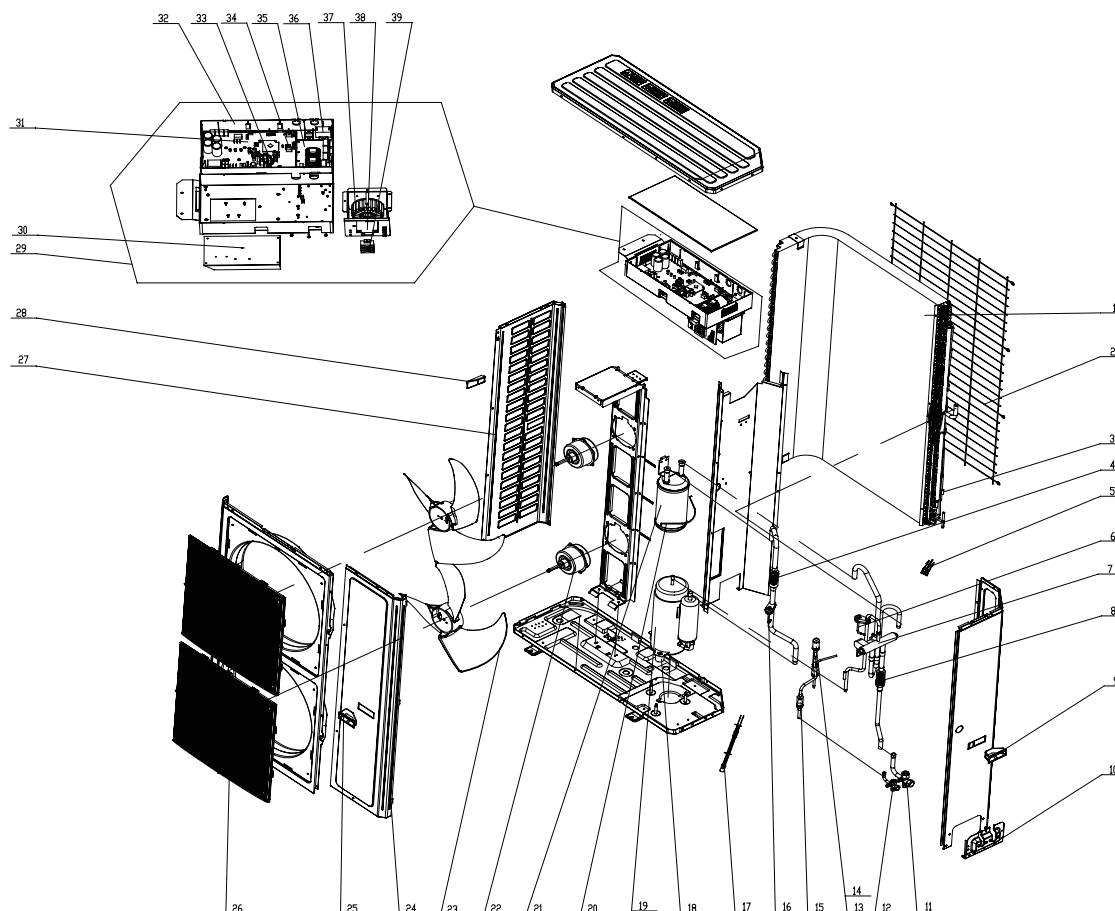

NO.	Description	GUHD48NK3CO	
		CF090W0320	Qty
		Name of Part	
1	Condenser Assy	'01025396	1
2	Rear Grill	'01575205	1
3	Temp. Sensor sleeving	'05212423	1
4	Strainer	'07210037	1
5	Temperature Sensor	'3900028002	1
6	Pressure Protect Switch	'460200061	1
7	4-way Valve	'43000338	1
8	Strainer	'07210037	1
9	Handle	'26235253	1
10	Valve Support Sub-Assy	'01715001	1
11	Gas Valve Sub-Assy	'07103030	1
12	Cut-off Valve	'07130209	1
13	Electronic Expansion Valve	'07334309	1
14	Electric expand valve fitting	'4300010810	1
15	Bidirection Strainer	'07220016	1
16	Pressure Protect Switch	'46020007	1
17	electrical heater	'765152123	1

18	Compressor Gasket	'76815204	3
19	Compressor and fittings	'00205224	1
20	Liquid Accumulator Clamp	'01745001	1
21	Gas-liquid Separator Sub-Assy	'07225018	1
22	Fan Motor	'1501506105	2
23	Axial Flow Fan	'10335008	2
24	Front Side Plate	'01315364P	1
25	Handle	'26235253	1
26	Front grill	'22415002	2
27	Left Side Plate	'01315366P	1
28	left handle	'26235401	1
29	Electric Box Assy	'01395965	1
30	Radiator	'49010252	1
31	Main Board	30224304	1
32	Electric Box	'26904131	1
33	High Frequency Transformer	'43110030	1
34	Relay	'44020378	2
35	Filter Board	30228115	0
36	Capacitor CBB61	'33010010	2
37	Inductance	'43120122	2
38	Breaker	'46020018	1
39	Terminal Board	'42011242	1

Model: GUHD48NK3C1O Exploded View and spare parts list

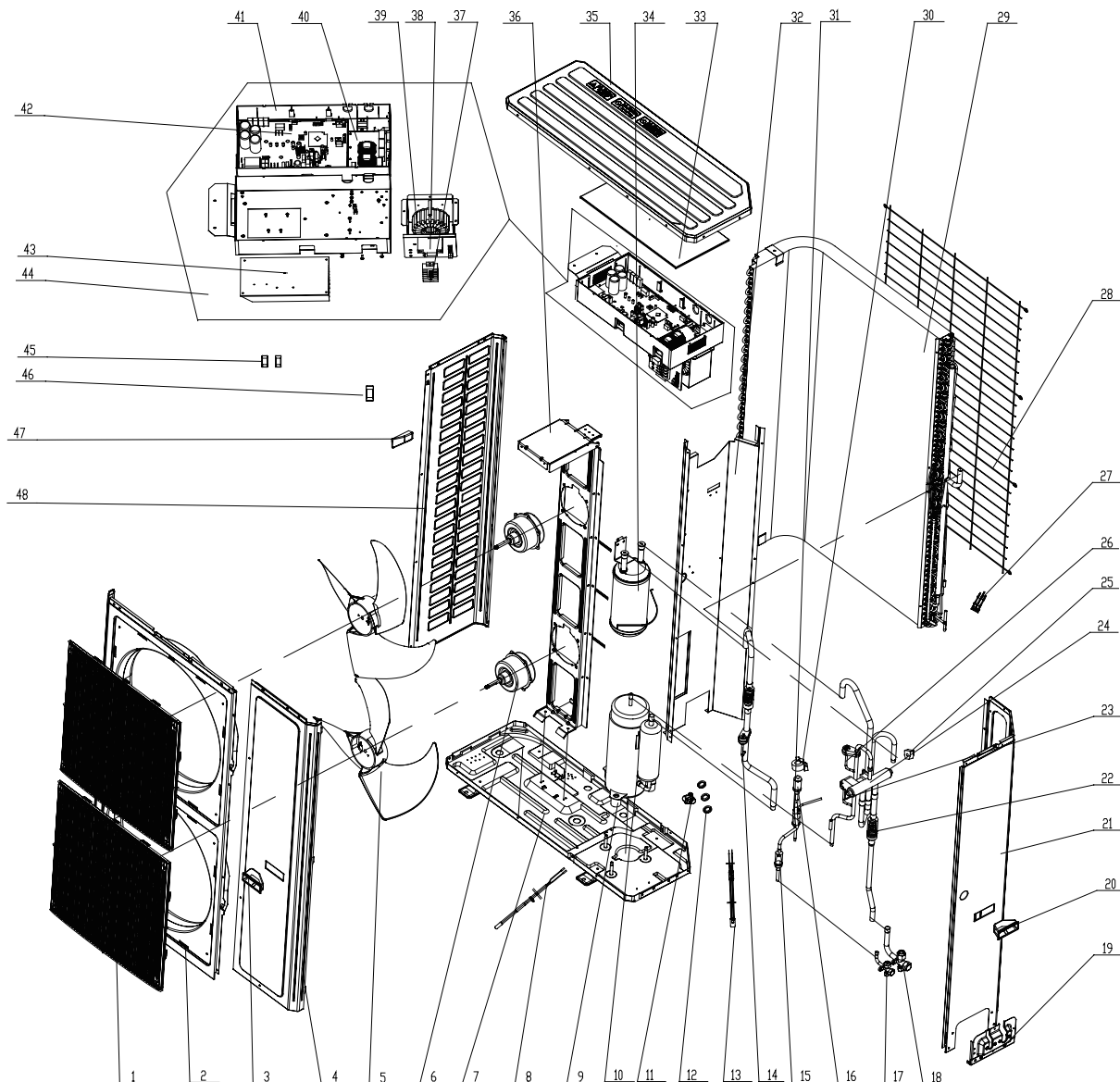

NO.	Description	GUHD48NK3C1O	Qty
		CF090W0550	
		Part Code	
1	Front Grill	'22415002	2
2	Cabinet	'01515204P	1
3	Handle	'26235253	1
4	Front Side Plate	'01315364P	1
5	Axial Flow Fan	'10335008	2
6	Fan Motor	1570411502	2
7	Chassis Sub-assy	01195710P	1
8	Electrical Heater	765100048	1
9	Compressor Gasket	'76815204	3
10	Compressor and fittings	'00205224	1
11	Drainage Connector	'06123401	1
12	Drainage Plug	'06813401	3
13	electrical heater	'765152123	1
14	Pressure Protect Switch	'46020007	1

15	Bidirection Strainer	'07220016	1
16	Electronic Expansion Valve	'07334194	1
17	Cut off Valve	'07130209	1
18	Gas Valve Sub-Assy	'07103030	1
19	Valve Support Sub-Assy	'01715001	1
20	Handle	'26235253	1
21	Rear Side Plate Sub-Assy	'01314306P	1
23	Pressure Protect Switch	'46020003	1
24	4-way Valve	'43000338	1
25	Magnet Coil	'4300040032	1
26	Pressure Protect Switch	'46020006	1
27	Temperature Sensor	3900028015G	1
28	Rear Grill	'01575205	1
29	Condenser Assy	'01025396	1
30	Electric Expand Valve Fitting	'4300010810	1
31	Strainer	'07210045	1
32	Clapboard Assy	01245269	1
33	Electric Box Cover	01424235	1
34	Gas-liquid Separator Sub-Assy	'07225018	1
35	Top Cover	'01265356P	1
36	Motor Support Assy	01805722	1
37	Terminal Board	42011242	1
38	Overcurrent Circuit Breaker	46020018	1
39	Inductance	43120122	1
40	Filter Board	30228115	1
41	Electric Box	26904131	1
42	Main Board	30224076	1
43	Radiator	49010007	1
44	Electric Box Assy	02405226	1
45	Magnetic Ring	49010104	2
46	Magnetic Ring	49010109	1
47	Left Handle	'26235401	1
48	Left Side Plate	'01315366P	1

Model: GUHD36NM3CO/GUHD42NM3CO Exploded View and spare parts list

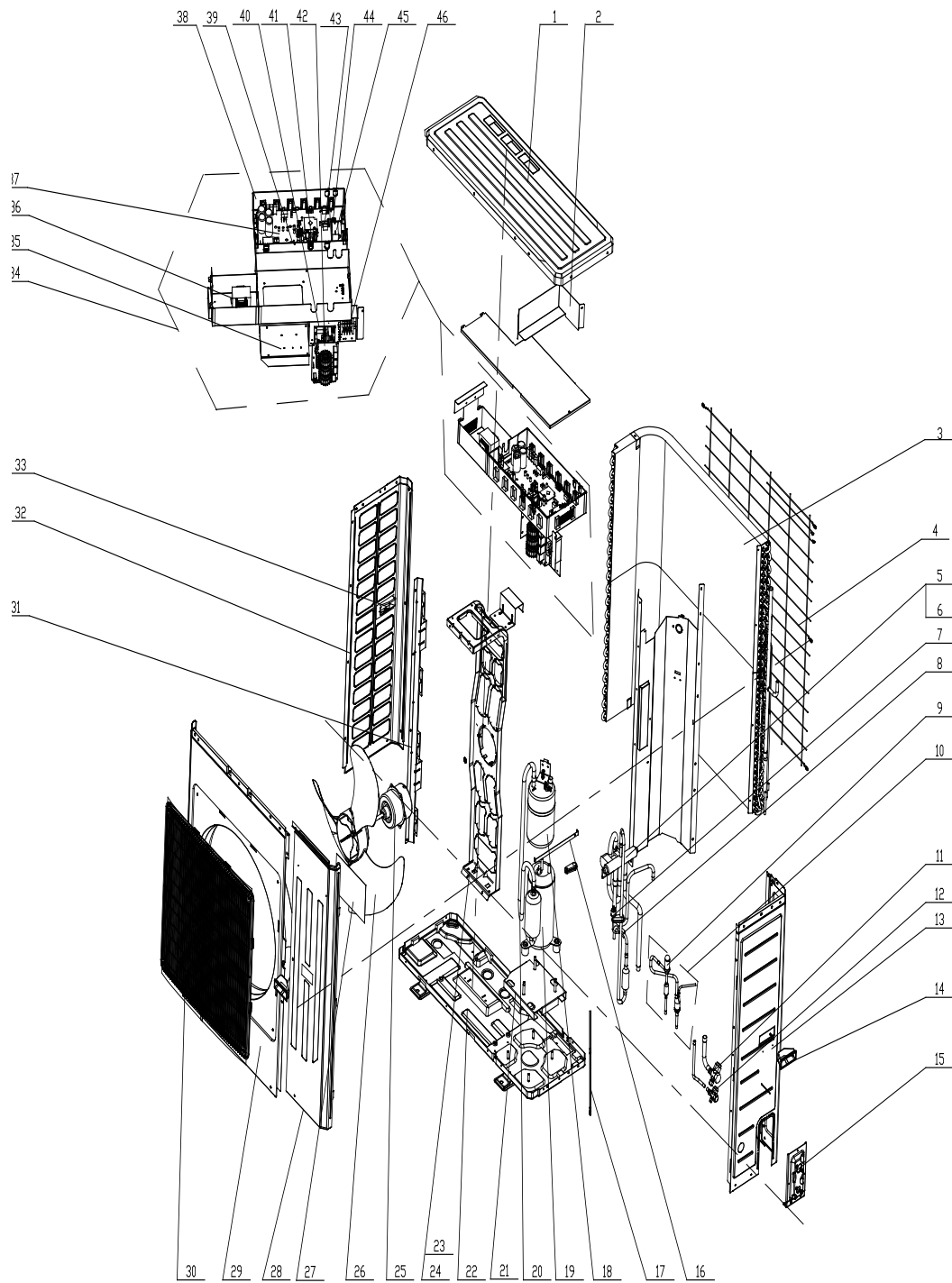

NO.	Description	GUHD36NM3CO	GUHD36NM3CO	GUHD42NM3CO	GUHD42NM3CO	Qty
		CF090W0410	CF090W0411	CF090W0420	CF090W0421	
	Name of Part	Part Code	Part Code	Part Code	Part Code	
1	Top Cover	'01255009P	'01255009P	'01255009P	'01255009P	1
2	Air Guard	'01355204	'01355204	'01355204	'01355204	1
3	Condenser Assy	01125373	'01125392	'01125392	'01125392	1
4	Rear Grill	'01475012	'01475012	'01475012	'01475012	1
5	4-way Valve Assy	04145342	'04145748	'04145362	04145748	1
6	4-way Valve	'43000338	'43000338	'43000338	'43000338	1
7	Pressure Protect Switch	'46020006	'46020006	'46020006	'46020006	1
8	Temperature Sensor	'3900028002	'3900028002	'3900028002	'3900028002	1
9	Electronic Expansion Valve	'07334194	'07334194	'07334194	'07334194	1
10	Electric Expansion Valve Sub-Assy	07335263	'07335271	'07335271	'07335271	1
11	Cut-off Valve	'07133157	'07133157	'07133157	'07133157	1
12	Cut-off Valve	071302391	071302391	'07133185	071302391	1
13	Right Side Plate Sub-Assy	'01305441P	'01305441P	'01305441P	'01305441P	1
14	Handle	'26235253	'26235253	'26235253	'26235253	2
15	Valve Support Sub-Assy	'01715257P	'01715257P	'01715257P	'01715257P	1
16	Clamp	'02145008	'02145008	'02145008	'02145008	1
17	Electrical heater	'76518732	'76518732	'76518732	'76518732	1
18	Gas-liquid Separator Sub-Assy	'07255201	'07255201	'07255201	'07255201	1
19	Compressor and fittings	'00205236	00200008	'00205236	00200008	1
20	Inhalation Tube 1	'04655520	'04655520	'04655520	'04655520	1
21	Retaining Plate Sub-Assy	'01845235P	'01845235P	'01845235P	'01845235P	1
22	Chassis Sub-assy	'01195244P	'01195244P	'01195244P	'01195244P	1
23	Motor Support Assy	'01805396	'01805396	'01805396	'01805396	1
24	Motor Support Sub-Assy	'01705111	'01705111	'01705111	'01705111	1
25	Fan Motor	'150154516	'150154516	'150154516	'150154516	1
26	Axial Flow Fan	'10335010	'10335010	'10335010	'10335010	1
27	Insulated board (cover of electric box)	'20113003	'20113003	'20113003	'20113003	1
28	Front Side Plate Sub-Assy	'01305508	'01305508	'01305508	'01305508	1
29	Cabinet	'01435007P	'01435007P	'01435007P	'01435007P	1
30	Front Grill	'22415005	'22415005	'22415005	'22415005	1
31	Condenser support plate	'01895309	'01895309	'01305064P	'01305064P	1
32	Left Side Plate	'01795020	'01795020	'01795020	'01795020	1
33	left handle	'26235401	'26235401	'26235401	'26235401	1
34	Electric Box Assy	'01395956	'01395956	'01395956	'01395956	1
35	Radiator	'49018113	'49018113	'49018113	'49018113	1
36	Reactor	'43130178	'43130178	'43130178	'43130178	1
37	Main Board	'30228806	'30228806	'30228806	'30228806	1
38	Electric Box	'26905211	'26905211	'26905211	'26905211	1
39	XY Capacitor	'33030013	'33030013	'33030013	'33030013	1
40	Main Board	'30224311	'30224311	'30224311	'30224311	1
41	High-frequency transformer	'43110030	'43110030	'43110030	'43110030	1
42	Filter Board	'30228118	'30228118	'30228118	'30228118	1
43	Relay	'44020378	'44020378	'44020378	'44020378	1
44	Terminal Board	'42011103	'42011103	'42011103	'42011103	1
45	Capacitor	'33010009	'33010009	'33010009	'33010009	1
46	Terminal Board	42011221	42011221	'42011043	'42011221	1

Model: GUHD36NM3C10/GUHD42NM3C10 Exploded View and spare parts list

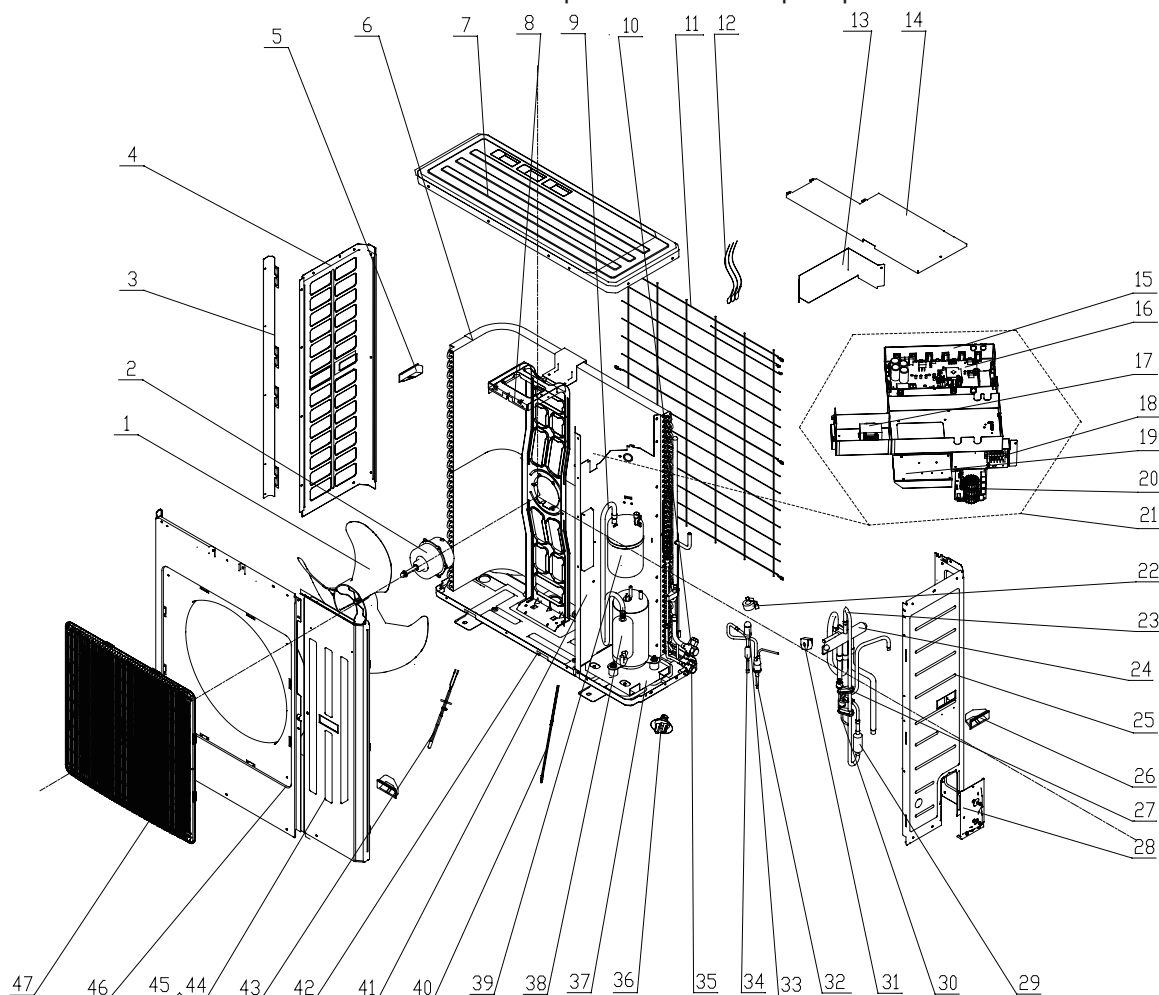

NO.	Description Name of Part	GUHD36NM3C10	GUHD42NM3C10	Qty
		CF090W0560	CF090W0570	
		Part Code	Part Code	
1	Axial Flow Fan	'10335010	'10335010	1
2	Fan Motor	'1570280201	'1570280201	1
3	Condenser support plate	"01795020	'01795020	1
4	Left Side Plate	'01305064P	'01305064P	1
5	Left Handle	'26235401	'26235401	1
6	Condenser Assy	'01125392	'01125392	1
7	Top Cover	'01255009P	'01255009P	1
8	Motor Support Sub-Assy	'01705111	'01705111	1
9	Inhalation Tube 1	'04655520	'04655520	1
10	Cut off Valve	'07133157	'07133157	1
11	Rear Grill	'01475012	'01475012	1
12	Temperature Sensor	'3900028002G	'3900028002G	1
13	Air Guard	'01355204	'01355204	1
14	Electric Box Cover	01265398	01265398	1
15	Electric Box	26905211	26905211	1
16	Main Board	30228006	30228006	1
17	Reactor	43130178	43130178	1
18	Terminal Board	42011221	42011221	1
19	Radiator	49018113	49018113	1
20	Filter Board	30228118	30228118	1

21	Electric Box Assy	02405223	02405223	1
22	Electric expand valve fitting	'4300010812	'4300010812	1
23	4-Way Valve Assy	'04145733	04145732	1
24	4-way Valve	'43000338	'43000338	1
25	Right Side Plate Sub-Assy	'01305441P	'01305441P	1
26	Handle	'26235253	'26235253	2
27	Pressure Protect Switch	'46020006	'46020006	1
28	Valve Support Sub-Assy	'01715257P	'01715257P	1
29	Strainer	'07215201	'07215201	1
30	Pressure Protect Switch	'46020003	'46020003	1
31	Magnet Coil	'4300040029	'4300040029	1
32	Electric Expansion Valve Sub-Assy	'07335271	'07335271	1
33	Electronic Expansion Valve	'07334194	'07334194	1
34	Strainer	'07210045	'07210045	1
35	Cut off Valve	'071302391	'071302391	1
36	Drainage Joint	'26113009	'26113009	1
37	Retaining Plate Sub-Assy	'01845235P	'01845235P	1
38	Compressor and fittings	'00200008	'00200008	1
39	Gas-liquid Separator Sub-Assy	'07255201	'07255201	1
40	Electrical heater	'76518732	'76518732	1
41	Clapboard Sub-Assy	'01245261	'01245261	1
42	Chassis Sub-assy	'01195315P	'01195315P	1
43	Electrical Heater	'765100047	'765100047	1
44	Front Side Plate Sub-Assy	'01305508	'01305508	1
45	Front Side Plate	'01305065P	'01305065P	1
46	Cabinet	'01435007P	'01435007P	1
47	Front Grill	'22415005	'22415005	1

Model: GUHD48NM3CO/GUHD60NM3CO Exploded View and spare parts list

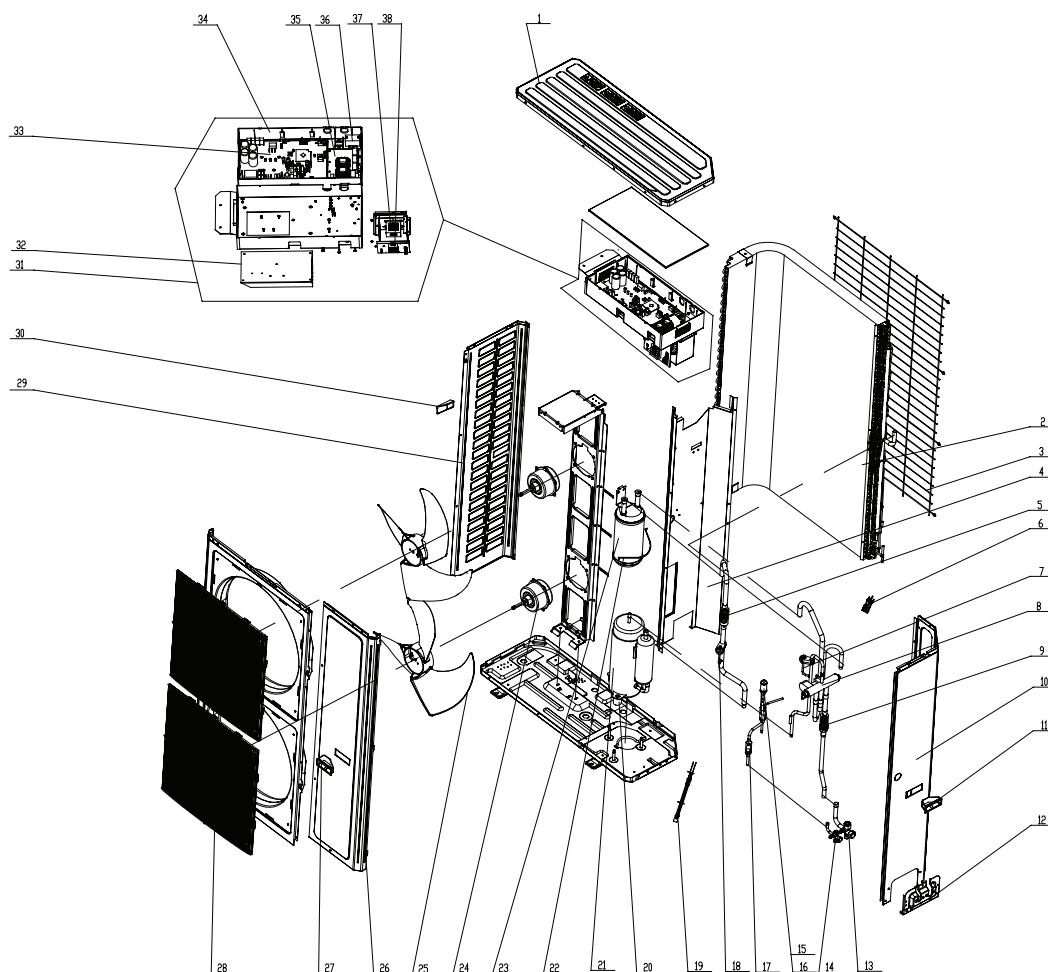

NO.	Description	GUHD48NM3CO	GUHD60NM3CO	Qty
		CF090W0430	CF090W0440	
		Part Code	Part Code	
1	Top Cover	'01265356P	01265356P	1
2	Condenser Assy	01025396	'01125410	1
3	Rear Grill	'01575205	'01575205	1
4	Clapboard Sub-Assy	01244144	01244144	1
5	Strainer	'07210037	'07210037	1
6	Temperature Sensor	'3900028002	'3900028002	1
7	Pressure Protect Switch	'460200061	'460200061	1
8	4-way Valve	'43000338	'43000338	1
9	Strainer	07210045	07210045	1
10	Rear Side Plate Sub-Assy	'01314306P	'01314306P	1
11	Handle	'26235253	'26235253	1
12	Valve Support Sub-Assy	'01715001	'01715001	1
13	Gas Valve Sub-Assy	07103030	07103030	1
14	Cut-off Valve	'07130209	'07130209	1
15	Electronic Expansion Valve	07334194	07334194	1
16	Electric expand valve fitting	'4300010813	'4304000101	1
17	Bidirection Strainer	'07220016	'07220016	1

18	Pressure Protect Switch	'46020007	'46020007	1
19	Electrical Heater	'765152123	'765152123	1
20	Compressor Gasket	'76815204	'76815204	3
21	Compressor and fittings	'00204126	'00204126	1
22	Liquid Accumulator Clamp	01745001	'02145435	1
23	Gas-liquid Separator Sub-Assy	'07225018	07225016	1
24	Fan Motor	'1501506105	1570531302	2
25	Axial Flow Fan	'10335008	'10335008	2
26	Front Side Plate	'01315364P	'01315364P	1
27	Handle	'26235253	'26235253	1
28	Front grill	'22415002	'22415002	2
29	Left Side Plate	'01315366P	'01315366P	1
30	Left Handle	'26235401	'26235401	1
31	Electric Box Assy	01395967	'01395966	1
32	Radiator	49018028	49018028	1
33	Main Board	30228807	30228807	1
34	Electric Box	26904131	26904131	1
35	Main Board	30228118	30228118	1
36	Capacitor	33010010	33010037	2
37	Reactor	43138004	43138004	1
38	Terminal Board	42011223	'42011223	1

Model: GUHD48NM3C10/GUHD60NM3C10 Exploded View and spare parts list

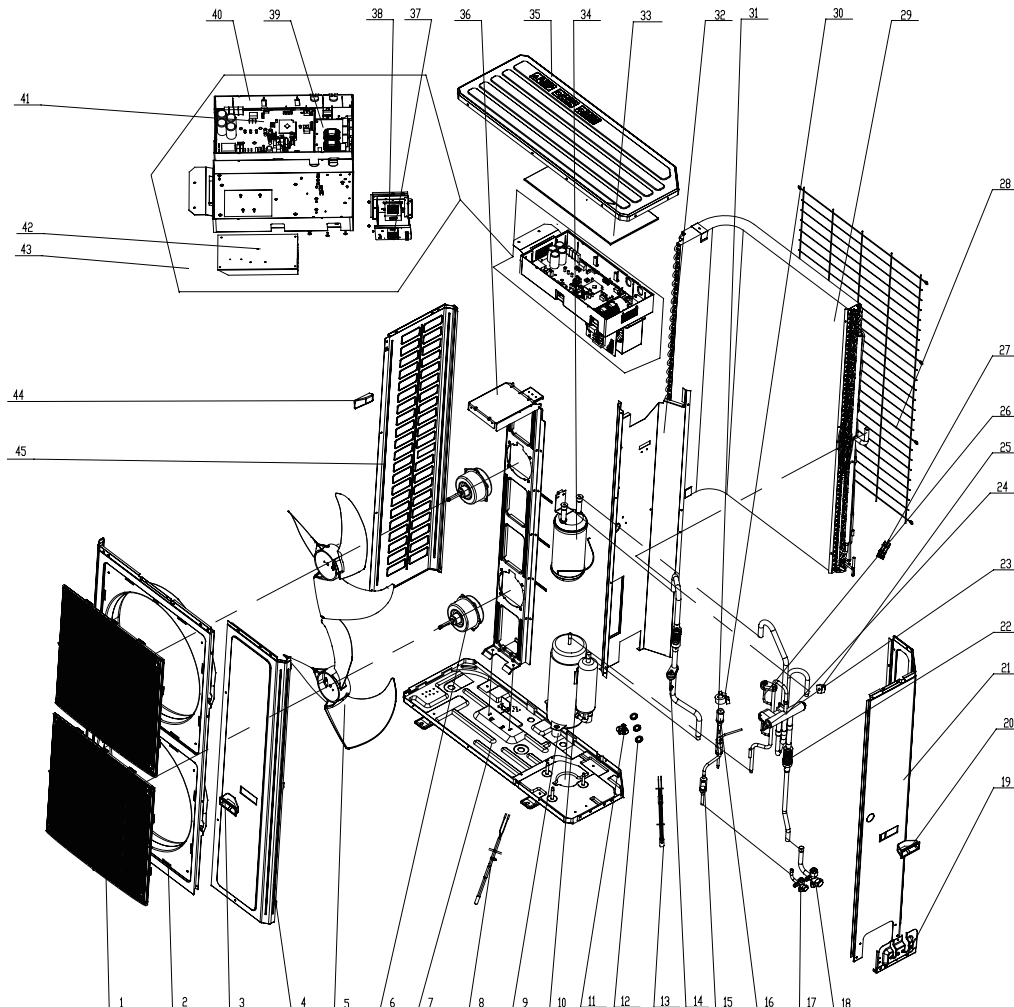

NO.	Description	GUHD48NM3C1O	GUHD60NM3C1O	Qty
		CF090W0580	CF090W0590	
	Name of Part	Part Code	Part Code	
1	Front Grill	'22415002	'22415002	2
2	Cabinet	'01515204P	'01515204P	1
3	Handle	'26235253	'26235253	1
4	Front Side Plate	'01315364P	'01315364P	1
5	Axial Flow Fan	'10335008	'10335008	2
6	Fan Motor	1570280203	1570280203	2
7	Chassis Sub-assy	'01195710P	'01195710P	1
8	Electrical Heater	'765100047	'765100047	1
9	Compressor Gasket	'76815204	'76815204	3
10	Compressor and fittings	'00204126	'00204126	1
11	Drainage Connector	'06123401	'06123401	1
12	Drainage Plug	'06813401	'06813401	3
13	Electrical heater	'765152123	'765152123	1
14	Pressure Protect Switch	'46020007	'46020007	1
15	Bidirection Strainer	'07220016	'07220016	1
16	Electronic Expansion Valve	'07334194	'07330001	1
17	Cut off Valve	'07130209	'07130209	1
18	Gas Valve Sub-Assy	'07103030	'07103030	1
19	Valve Support Sub-Assy	'01715001	'01715001	1
20	Handle	'26235253	'26235253	1
21	Rear Side Plate Sub-Assy	'01314306P	'01314306P	1
22	Strainer	'07210037	'07210037	1
23	Pressure Protect Switch	'46020003	'46020003	1
24	4-way Valve	'43000338	'43000338	1
25	Magnet Coil	'4300040032	'4300040032	1
26	Pressure Protect Switch	'46020006	'46020006	1
27	Temperature Sensor	'3900028015G	'3900028015G	1
28	Rear Grill	'01575205	'01575205	1
29	Condenser Assy	'01025396	0125747	1
30	Electric expand valve fitting	'4300010813	'4304000101	1
31	Strainer	'07210045	'07210045	1
32	Clapboard Assy	'01245269	'01245269	1
33	Electric Box Cover	'01424235	'01424235	1
34	Gas-liquid Separator Sub-Assy	'07225018	'07225016	1
35	Top Cover	'01265356P	'01265356P	1
36	Motor Support Assy	'01805722	'01805722	1

37	Terminal Board	42011223	42011223	1
38	Reactor	43138004	43138004	1
39	Filter Board	30228118	30228118	1
40	Electric Box	26904131	26904131	1
41	Main Board	30228007	30228007	1
42	Radiator	49018028	49018028	1
43	Electric Box Assy	02405225	02405225	1
44	Left Handle	'26235401	'26235401	1
45	Left Side Plate	'01315366P	'01315366P	1

5.2 Indoor Unit

5.2.1 Duct Type

Model:GFH09K3CI exploded view and spare parts list

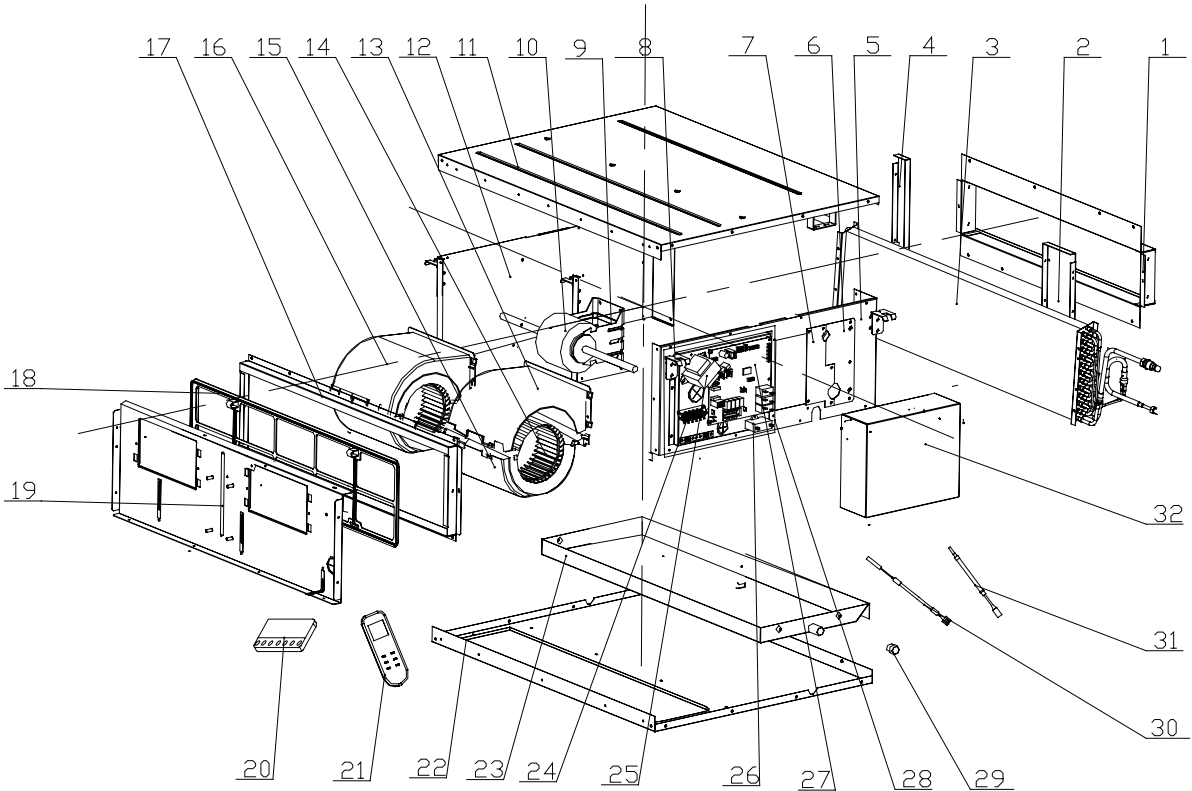

NO.	Description	GFH09K3CI	Qty
		CF060N0220	
Name of Part		Part Code	
1	Side Plate of Air outlet	'01494118	1
2	Left Support of Evaporator	'01094122	1
3	Evaporator Assy	'01025372	1
4	Right Support of Evaporator	'01094121	1
5	Left Side Plate Assy	'01314172	1
6	Seal Of Left Side Plate Sub-Assy	'01494115	1
7	Seal Of Left Connection Pipe Sub-Assy	'01494132	1
8	Hook	'02112446	4
9	Motor Support	0170905901	1

10	Fan Motor	'1570520103	1
11	Top Cover Board Assy	'01264176	1
12	Right Side Plate Assy	'01314175	1
13	Front volute casing	'22202030	1
14	Centrifugal fan	'10319051	1
15	Propeller Housing	'22202029	1
16	Motor Sub-Assy	150024011	2
17	Border Plate Assy of Air Return End	'02225234	1
18	Filter Sub-Assy	'11725202	1
19	Fan Motor Mounting Plate Sub-Assy	'01324341	1
20	Display Board	'30294219	1
21	Remote Controller	'305050031	1
22	Lower Cover Plate Sub-Assy	'01264178	1
23	Water Tray Assy	01284153	1
24	Terminal Board	'42010194	1
25	Transformer	'43110239	1
26	Capacitor	'33010027	1
27	Main Board	'30228205	1
28	Electric Box Assy	'01395886	1
29	Choke Plug of Drain Pipe	'76712455	1
30	Tube Sensor	'390000596	1
31	Room Sensor	'39000191	1
32	Electric Box Cover	01424319	1

Model:GFH12K3CI/GFH18K3CI exploded view and spare parts list

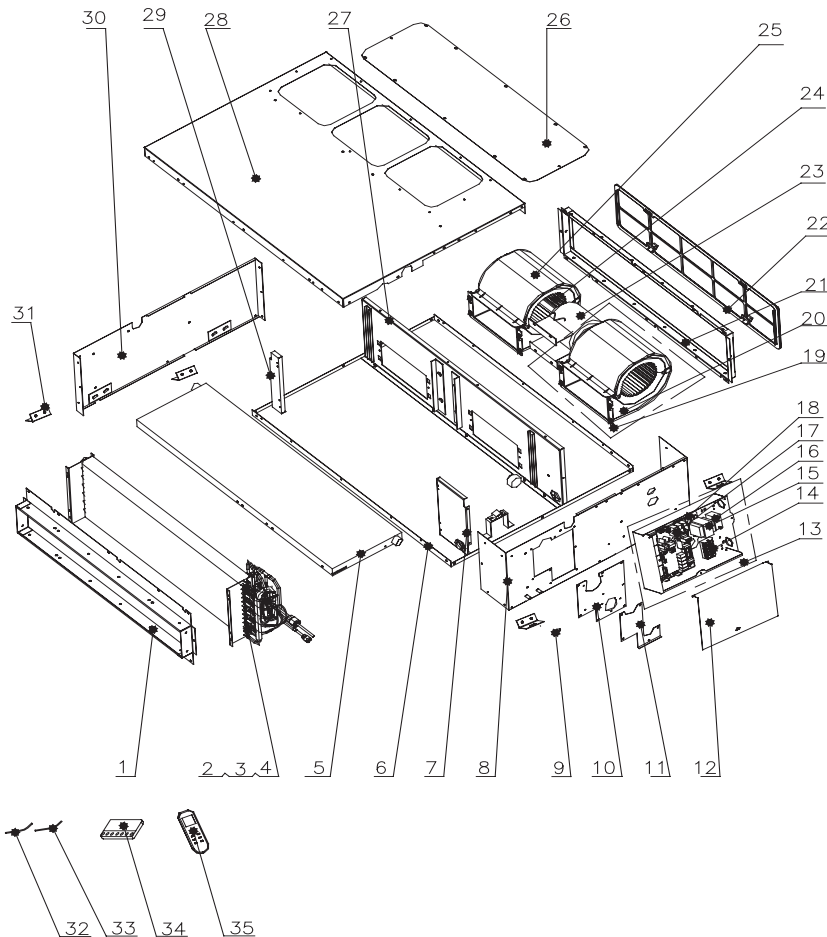

NO.	Description	GFH12K3CI	GFH18K3CI	Qty
		CF060N0231	CF060N0240	
	Name of Part	Part Code	Part Code	
1	Return air frame sub-assy	'01498641	'01498641	1
2	Evaporator Assy	'01025394	01025401	1
3	Strainer	'07212121	'07212121	1
4	Filter Sub-Assy	'11128633	'11128633	1
5	Water Tray Assy	'01285269	'01285269	1
6	Top Cover Board Sub-assy	'01259064	'01259064	1
7	left Supporting Board sub- assy of evapora tor	'01805280	'01805280	1
8	Left Side Plate Sub-Assy	01315429	01315429	1
9	Choke Plug of Water Pipe	'76712454	'76712454	1
10	Seal Of Connection Pipe	'01498644	'01498644	1
11	Seal Of Connection Pipe	'01498640	'01498640	1
12	Electric Box Cover	'01425269	'01425269	1
13	Electric Box Assy	'01395947	'01395981	1
14	Terminal Board	'42010194	'42010194	1
15	Transformer	'43110239	'43110239	1
16	Capacitor CBB61	'33010010	33010027	1
17	Main Board	'30228205	'30228205	1
18	Electrical Retaining Plate	'01845221	'01845221	1
19	Fan motor Sub-Assy	'15002401	'15002401	2
20	Propeller Housing	'22202029	'22202029	1
21	side plate sub- assy of return air frame	'02225234	'02225234	1
22	Filter	'11725202	'11725202	1
23	Fan Motor	1570520201	1501832202	1
24	Centrifugal fan	'10319051	'10319051	1
25	Front Volute Casing	'22202030	'22202030	1
26	Cover Of Air-In	'01258650	'01258650	1
27	Bottom Cover Plate	'01265409	'01265409	1
28	Fan Motor Mounting Plate Sub-Assy	'01339058	'01339058	1
29	Right Support of Evaporator	'01078625	'01078625	1
30	Right Side Plate Sub-Assy	'01308670	'01308670	1
31	Tube Sensor	'390001921G	'390001921G	1
32	Temperature Sensor	'3900012123G	'3900012123G	1
33	Display Board	'30294219	'30294219	1
34	Remote Controller	'305050031	'305050031	1

Model: GFH24K3CI exploded view and spare parts list.

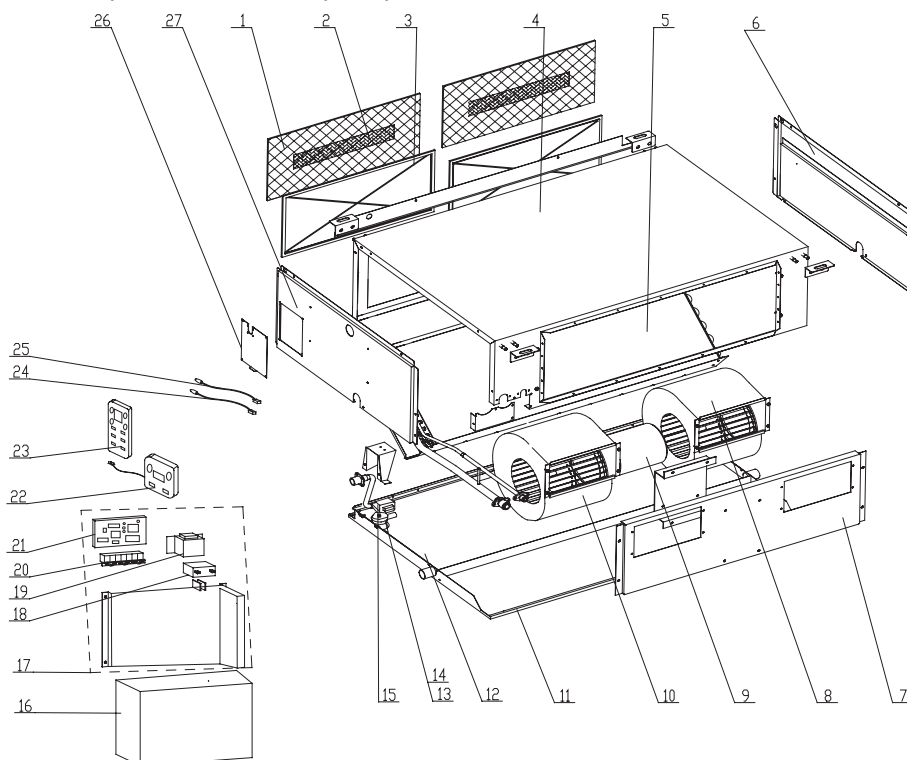

NO.	Description	GFH24K3CI	Qty
		CF060N0250	
		Part Code	
1	Filter	11125304	2
2	Filter	111200515	2
3	Filter Sub-Assy	11125303	2
4	Top Cover Board Assy	01265301	1
5	Evaporator Assy	01025301	1
6	Right Side Plate Sub-Assy	01315304	1
7	Fan Mounting Plate Assy	01325301	1
8	Motor	15012454	1
9	Fan Motor	15705304	1
10	Motor	15012458	1
11	Lower Cover Plate Sub-Assy	01265304	1
12	Water Tray Assy	01285317	1
13	Water Pump		0
14	Water Pump Assy		0
15	Water Level Switch		0
16	Electric Box Cover	01425269	1
17	Electric Box Assy	01395777	1
18	Capacitor CBB61	33010014	1
19	Transformer	43110239	1
20	Terminal Board	42010194	1
21	Main Board	30228205	1
22	Display Board	30294219	1
23	Remote Controller	305050031	1
24	Ambient Temperature Sensor	3900012123	1
25	Tube sensor	3900012128	1
26	Seal of Connection Pipe	01495302	1
27	Left Side Plate Sub-Assy	01315343	1

Model: GFH30K3CI exploded view and spare parts list.

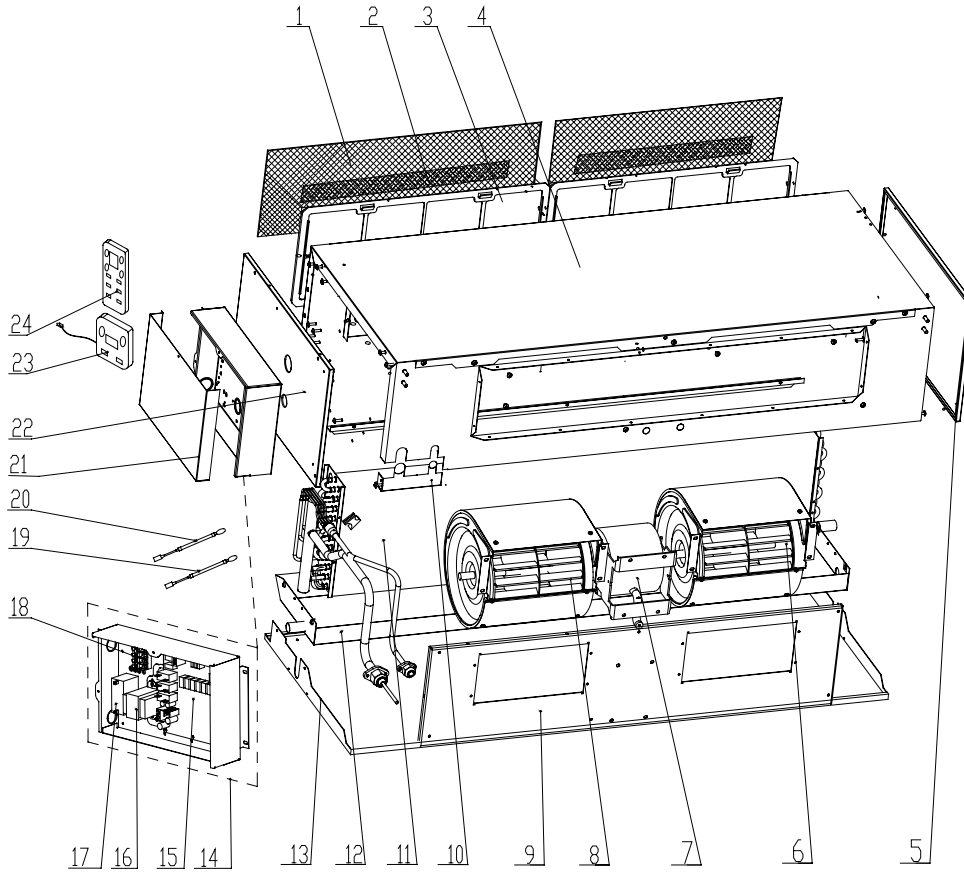

NO.	Description	GFH30K3CI	
		CF060N0260	Qty
		Name of Part	
1	Filter	'11125304	2
2	Filter	'111200515	2
3	Filter Sub-Assy	'11125303	2
4	Top Cover Board Assy	'01265301	1
5	Left Side Plate Sub-Assy	'01315293	1
6	Motor	'15012458	1
7	Fan Motor	'15705304	1
8	Motor	'15012454	1
9	Fan Mounting Plate Assy	'01325301	1
10	Seal of Connection Pipe	'01495304	1
11	Evaporator Assy	'01025387	1
12	Water Tray Assy	'01285317	1
13	Lower Cover Plate Sub-Assy	'01265304	1
14	Electric Box Assy	'01395777	1
15	Main Board	'30228205	1
16	Transformer	'43110239	1
17	Capacitor CBB61	'33010014	1
18	Terminal Board	'42010194	1
19	Tube sensor	'3900012128	1
20	Ambient Temperature Sensor	'3900012123	1
21	Electric Box Cover	'01425269	1
22	Right Side Plate Sub-Assy	'01315304	1
23	Display Board	'30294219	1
24	Remote Controller	'305050031	1

Model:GFH36K3CI/GFH42K3CI/GFH48K3CI exploded view and spare parts list.

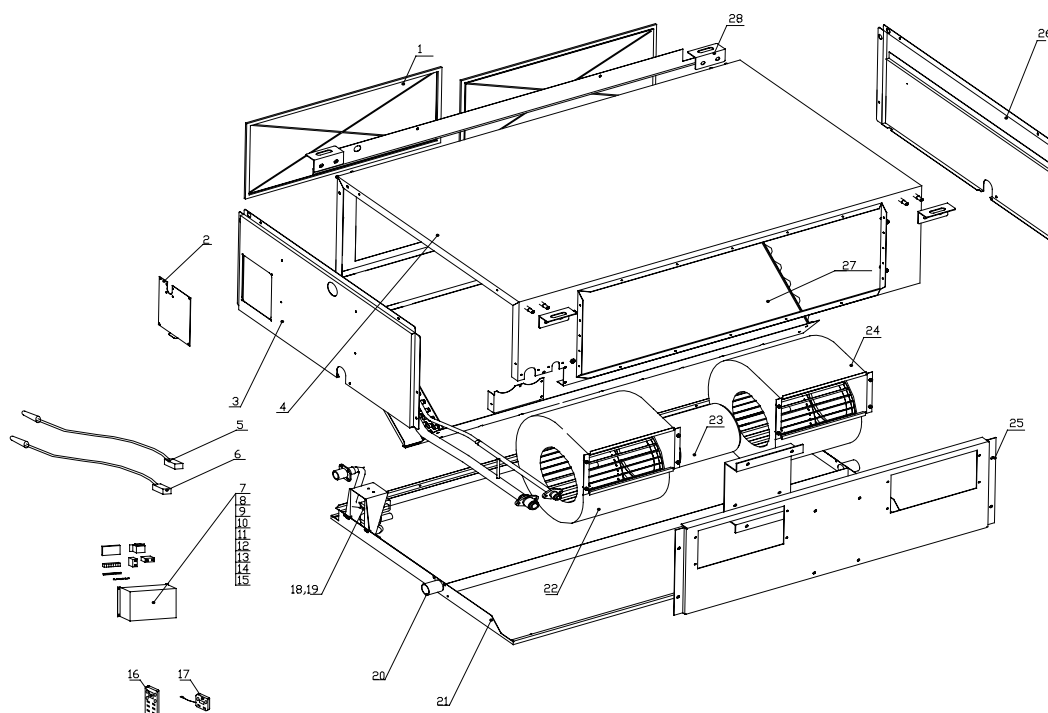

NO.	Description Name of Part	GFH36K3CI	GFH42K3CI	GFH48K3CI	Qty
		CF060N0270	CF060N0290	CF060N0280	
		Name Code	Name Code	Name Code	
1	Filter Sub-Assy	111253031	111253031	111253031	2
2	Seal of Connection Pipe	1495306	1495306	1495306	1
3	Left Side Plate	1315306	1315306	1315306	1
4	Top Cover Board Assy	01265306	01265306	01265306	1
5	Temp.sensor	3900012123 G	3900012123 G	3900012123 G	1
6	Temp.sensor	'3900012121G	'3900012121G	'3900012121G	1
7	Electric Box Assy	1399152	'01395776	01395968	1
8	Main Board	30228204	'30228205	30228205	1
9	Transformer	43110239	43110239	43110239	1
10	Capacitor	33010734	33010734	33010734	1
11	Capacitor				0
12	Terminal Board				0
13	Terminal Board	42010194	42010194	42010194	1
14	Isolation Washer C	70410523	70410523	70410523	1
15	Wire Clamp	71010102	71010102	71010102	2
16	Remote controller	305050031	305050031	305050031	1
17	Display board	30294219	30294219	30294219	1
18	water-level switch				0
19	Water pump				0
20	Water Tray Assy	01285323	'01285323	'01279114	1
21	Bottom Cover	15265301	15265301	15265301	1
22	Fan (right)	15018604	15018604	15018604	1
23	Motor FG500A	'15705305	'15705305	'15705305	1
24	Fan (left)	15018603	15018603	15018603	1
25	Fan Fixed Plate	1325220	1325220	1325220	1
26	Right Side Plate	1315309	1315309	1315309	1
27	Evaporator Assy	'01025358	'01025358	01025409	1
28	Hook	2112466	2112466	2112466	4

Model: GFH60K3CI exploded view and spare parts list.

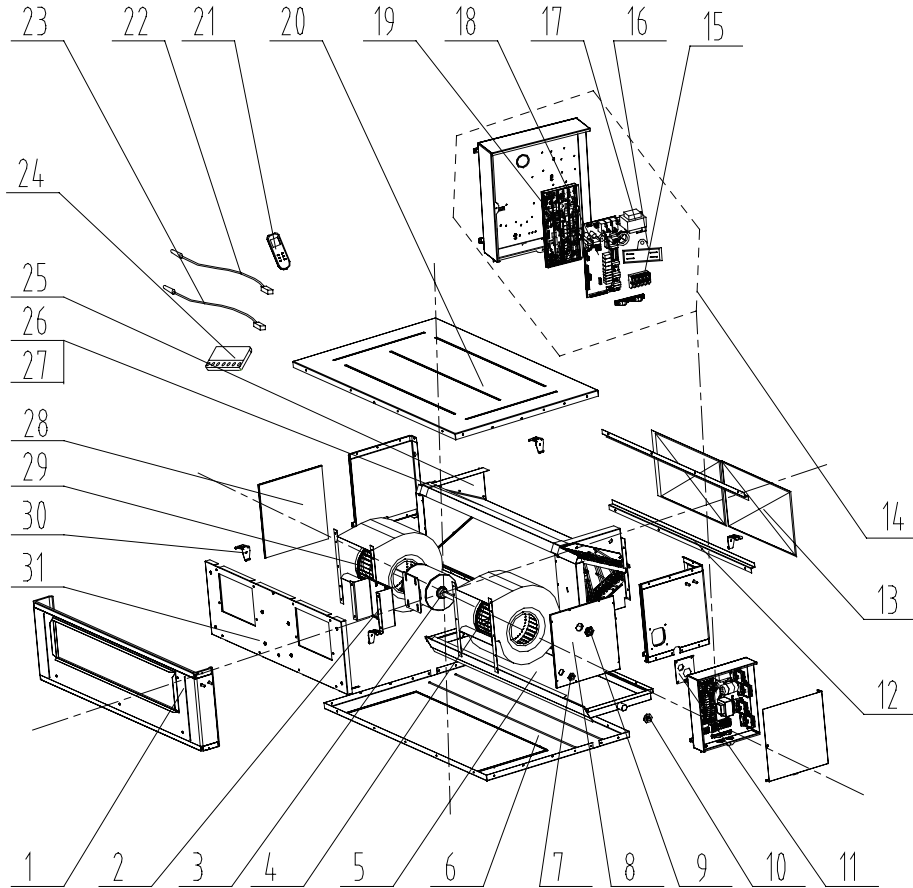

NO.	Description	GFH60K3CI	Qty
		CF060N0300	
	Name of Part	Name Code	
1	Front Side Plate Sub-Assy	'01315374	1
2	Motor Support Sub-Assy	'01804715	1
3	Fan Motor	1570523001	1
4	Motor	'15705307	1
5	Rubber Plug (Water Tray)	01285283	1
6	Bottom Cover Board Sub-Assy	'01265357	1
7	Cable-Cross Loop	'76510021	1
8	Right Side Plate Sub-Assy	'01315378	1
9	Cable-Cross Loop	'76515202	1
10	Choke Plug of Water Pipe	'76712454	1
11	Connection Pipe Cap Subassembly	'01495241	1
12	Guiding Slot of Filter Screen	'02285220	2
13	Filter Sub-Assy	'11725211	2
14	Electric Box Assy	'01395970	1
15	Terminal Board	'42010194	1
16	Capacitor	'3301074709	1
17	Transformer	'43110239	1

18	Main Board	'30228205	1
19	Electrical Retaining Plate	'01845221	1
20	Top Cover Board Assy	'01265359	1
21	Remote Controller	'305050031	1
22	Ambient Temperature Sensor	'39000208	1
23	Tube sensor	'3900012128	1
24	Display Board	'30294219	1
25	Sealing Plate	'01345218	1
26	Evaporator Assy	'01025405	1
27	Evaporator Assy	'01025404	1
28	Left Side Plate Sub-Assy	'01315376	1
29	Motor	'15705306	1
30	Hook	'02112466	4
31	Fan Mounting Plate Assy	'01324259	1

5.2.2 Cassette Type

Model:GKH12K3CI exploded view and spare parts list.

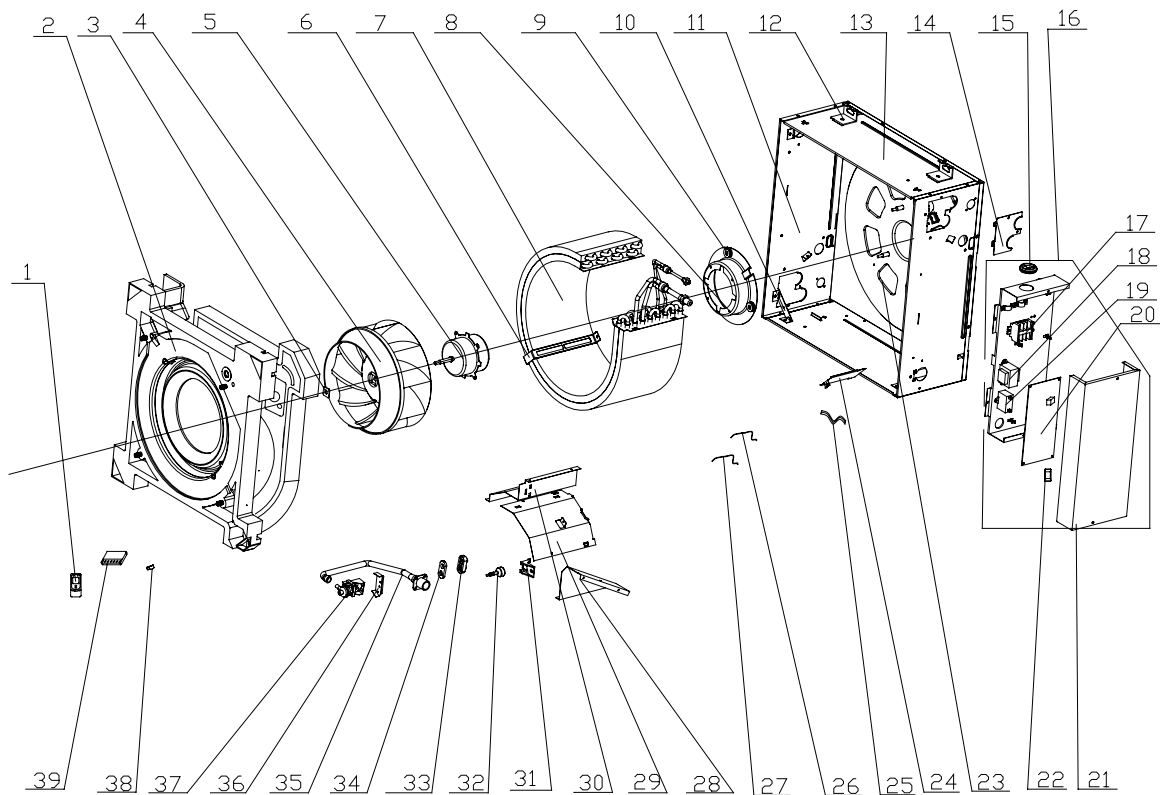

NO.	Description	GKH12K3CI	Qty
		ET010N0170	
	Name of Part	Name Code	
1	Remote Controller	'305125063	1
2	Water Tray Assy	'20182704	1
3	Sponge	'76712709	1
4	Centrifugal fan	'10312702	1
5	Fan Motor	15012707	1
6	Evaporator Support	'01072714	1
7	Evaporator Assy	'01029472	1
8	Motor support	'01702702	1
9	Motor Gasket	'76712705	3
10	Water Tray Support	'01332706	4
11	Front Side Plate	'01302741	2
12	Body Installing Support	'01332705	4
13	Right Side Plate Sub-Assy	'01302743	2
14	Tube Exit Plate Assy	'01382719	1
15	Cable-Cross Loop	'76515202	2
16	Electric Box Assy	'01399603	1
17	Terminal Board	'42010258	1
18	Transformer	'43110233	1
19	Capacitor CBB61	'33010026	1
20	Main Board	'30227110	1
21	Electric Box Cover	'01412723	1
22	Magnetic Ring	'49010104	1
23	Seat Board Sub-Assy	'01222712	1
24	pass wire plate	'01362701	1
25	Signal Wire	'40030079	1
26	Signal Wire	'390000592	1
27	Room Sensor	'39000191	1
28	Left Baffle Plate	'01362703	1
29	Evaporator Connection Board	'01072713	1
30	Right baffle Assy	'01362704	1
31	Water Level Switch Support	'24212705	1
32	Water Level Switch	'450127011	1
33	Pump Gasket 1	'76712707	1
34	Pump Gasket 2	76712708	1
35	Pump Drainpipe	'05232722	1
36	Pump Support Assy	'01332708	1
37	Water Pump	'43130320	1
38	Clamp (power cord)	'71010105	1
39	Display Board	'30294219	1

Model:GKH18K3CI exploded view and spare parts list.

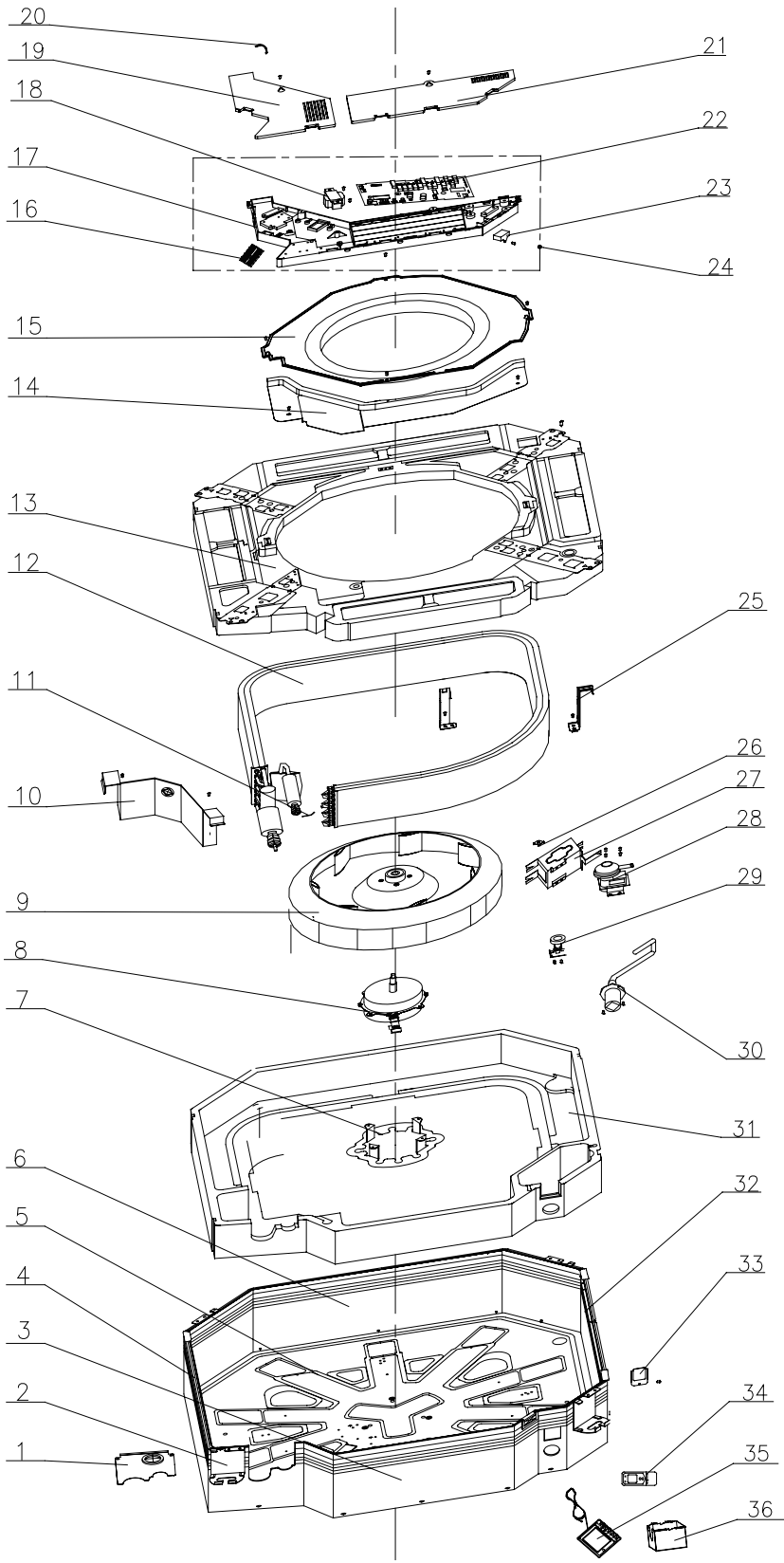

NO.	Description Name of Part	GKH18K3CI	Qty
		ET010N0180	
		Name Code	
1	Tube Exit plate Assy	'01382715	1
2	Body Fixing Plate	'01332701	4
3	Front Side Plate Assy	'01302718	1
4	Left Side Plate Assy	'01302715	1
5	Base Plate Assy	'01222701	1
6	Rear Side Plate Assy	'01302714	1
7	Motor Support	'10312701	1
8	Fan Motor	'15012703	1
9	Centifugal Fan	'10312705	1
10	Evaporator Linkage	'01074042	1
11	Tube sensor	'390001921	1
12	Evaporator Assy	'01029435	1
13	Water Tray Assy	'20182701	1
14	Electric Base Plate	'01412721	1
15	Flow-guide Loop	'10372701	1
16	Terminal Board	'42010258	1
17	Electric Box	'26909439	1
18	Transformer	'43110233	1
19	Electric Box Cover I	'20102702	1
20	Ambient Temperature Sensor	'390001911	1
21	Electric Box Cover II	'20102703	1
22	Main Board	'30227111	1
23	Capacitor	'33010010	1
24	Electric Box Assy	'01399604	1
25	Evaporator Support Assy	'01072703	2
26	Fan Fixer	10312701	1
27	Pump Support	'01332702	1
28	Water Pump	'43130324	1
29	Water Level Switch	'45010201	1
30	Pump Drainpipe	'05230026	1
31	Bottom Foam Assy	'52012722	1
32	Right Side Plate Assy	'01302716	1
33	Pump Cover Board Assy	'01252713	1
34	Remote Controller	'305125063	1
35	Display Board	'30294219	1
36	Electric Box	' 26909439	1

Model:GKH24K3CI exploded view and spare parts list.

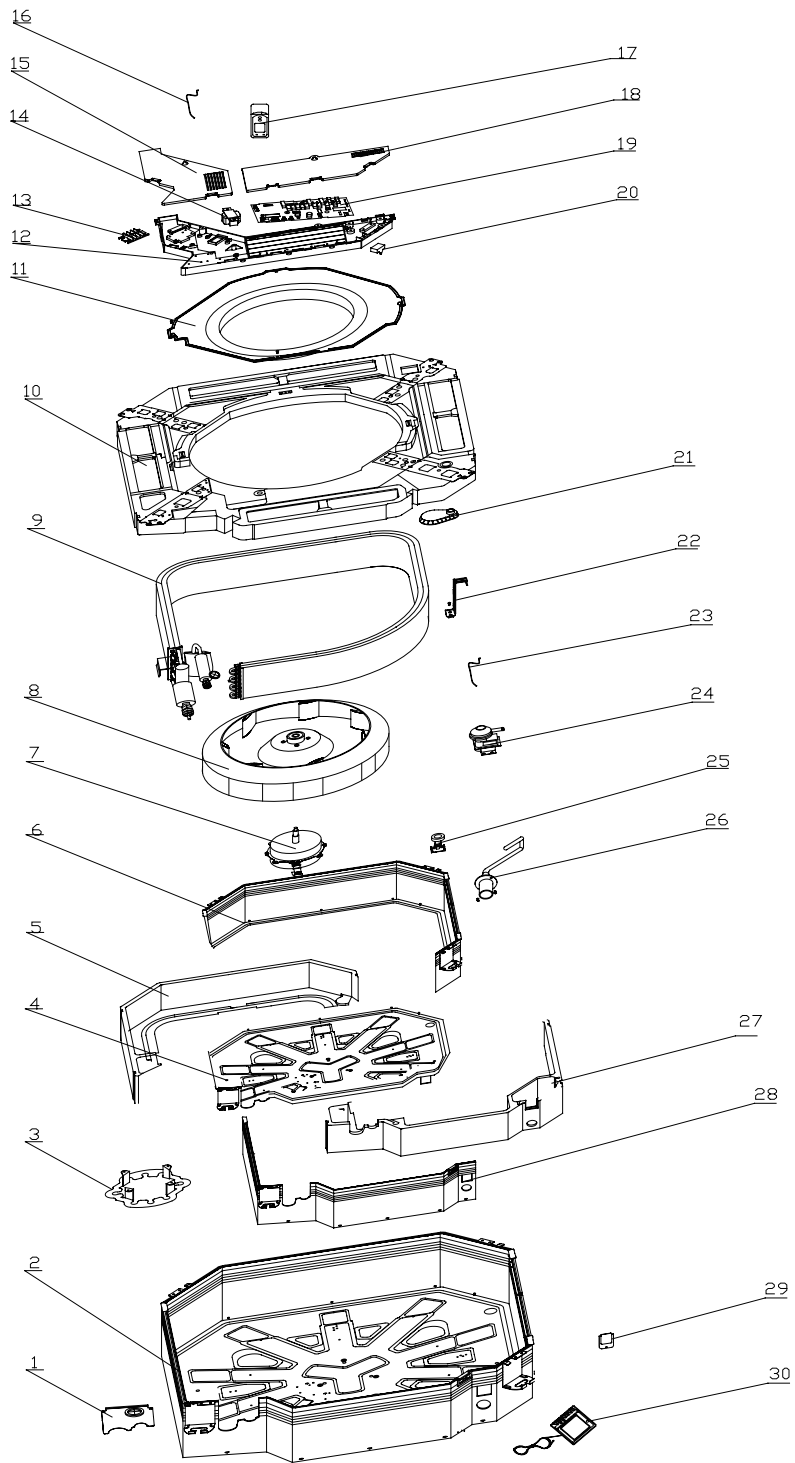

NO.	Description	GKH24K3CI	Qty
		ET010N0190	
	Name of Part	Part Code	
1	Tube Exit Plate Assy	'01382715	1
2	Shell Assy	'01432703	1
3	Motor support	'01702701	1
4	Base Plate Assy	'01222701	1
5	Right Side Plate Assy	'01302716	1
6	Rear side plate assy	'01302714	1
7	Fan Motor	'15709404	1
8	Centrifugal fan	'10312705	1
9	Evaporator Assy	'01029451	1
10	Water Tray Assy	'20182701	1
11	Diversion Circle	'10372701	1
12	Electric Box Assy	'01399604	1
13	Terminal Board	'42010258	1
14	Transformer	'43110233	1
15	Electric Box Cover Sub-Assy1	'20122054	1
16	Tube Sensor	'390001921	1
17	Remote Controller	'305125063	1
18	Electric Box Cover Sub-Assy2	'20122055	1
19	Main Board	'30227111	1
20	Capacitor CBB61	'33010010	1
21	Drain Hose Sub-Assy	'05232702	1
22	Evaporator Support Assy	'01072703	2
23	Room Sensor	'390001911	1
24	Water Pump	'43130324	1
25	Water Level Switch	'45010201	1
26	Pump Drainpipe	'05230026	1
27	Left Side Plate Assy	'01302715	1
28	Front side plate assy	'01302718	1
29	Pump Cover Board Assy	'01252713	1
30	Display Board	'30294219	1

Model:GKH30K3CI exploded view and spare parts list.

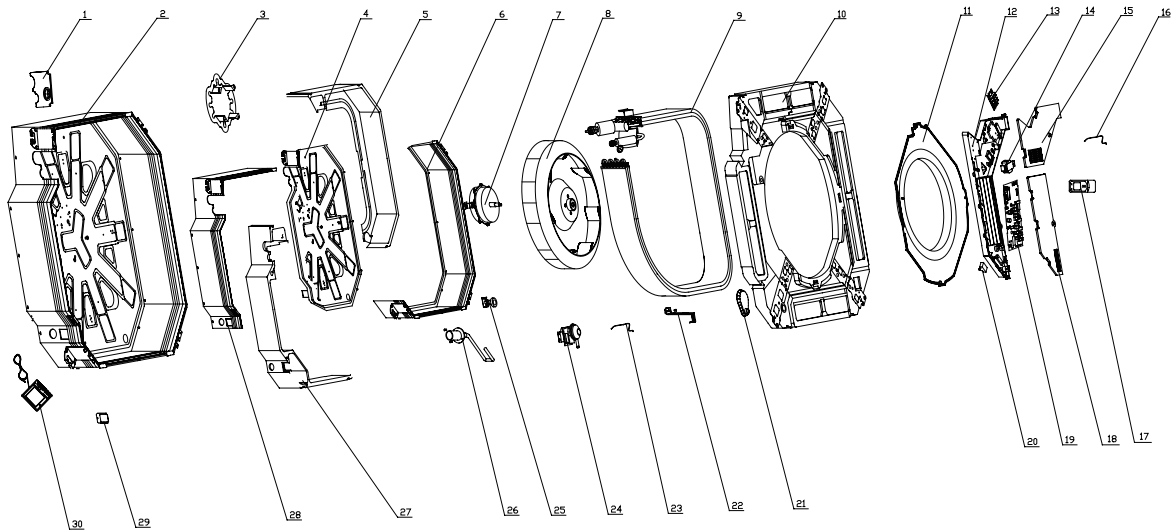

NO.	Description	GKH30K3CI	
		ET010N0200	
		Name of Part	Name Code
			Qty
1	Tube Exit Plate Assy	'01382715	1
2	Shell Assy		0
3	Motor support	'01702701	1
4	Base Plate Assy	'01222701	1
5	Right Side Plate Assy	'01302712	1
6	Rear side plate assy	'01302709	1
7	Fan Motor	'15012706	1
8	Centrifugal fan	'10310101	1
9	Evaporator Assy	1029423	1
10	Diversion Circle	'10372722	1
11	Electric Box Assy	'01399610	1
12	Terminal Board	'42010258	1
13	Transformer	'43110233	1
14	Electric Box Cover Sub-Assy1	'20122054	1
15	Tube Sensor	'390001921	1
16	Remote Controller	'305125063	1
17	Electric Box Cover Sub-Assy2	'20122055	1
18	Main Board	'30227111	1
19	Capacitor CBB61	'33010012	1
20	Drain Hose Sub-Assy	'05232702	1
21	Evaporator Support Assy	'01072707	2
22	Room Sensor	'390001911	1
23	Water Pump	'43130324	1
24	Water Level Switch	'45010201	1
25	Pump Drainpipe	'05230026	1
26	Left Side Plate Assy	'01302711	1
27	Front side plate assy	'01302713	1
28	Pump Cover Board Assy	'01252713	1
29	Display Board	'30294219	1

Model:GKH36K3CI/ GKH42K3CI exploded view and spare parts list.
Exploded View

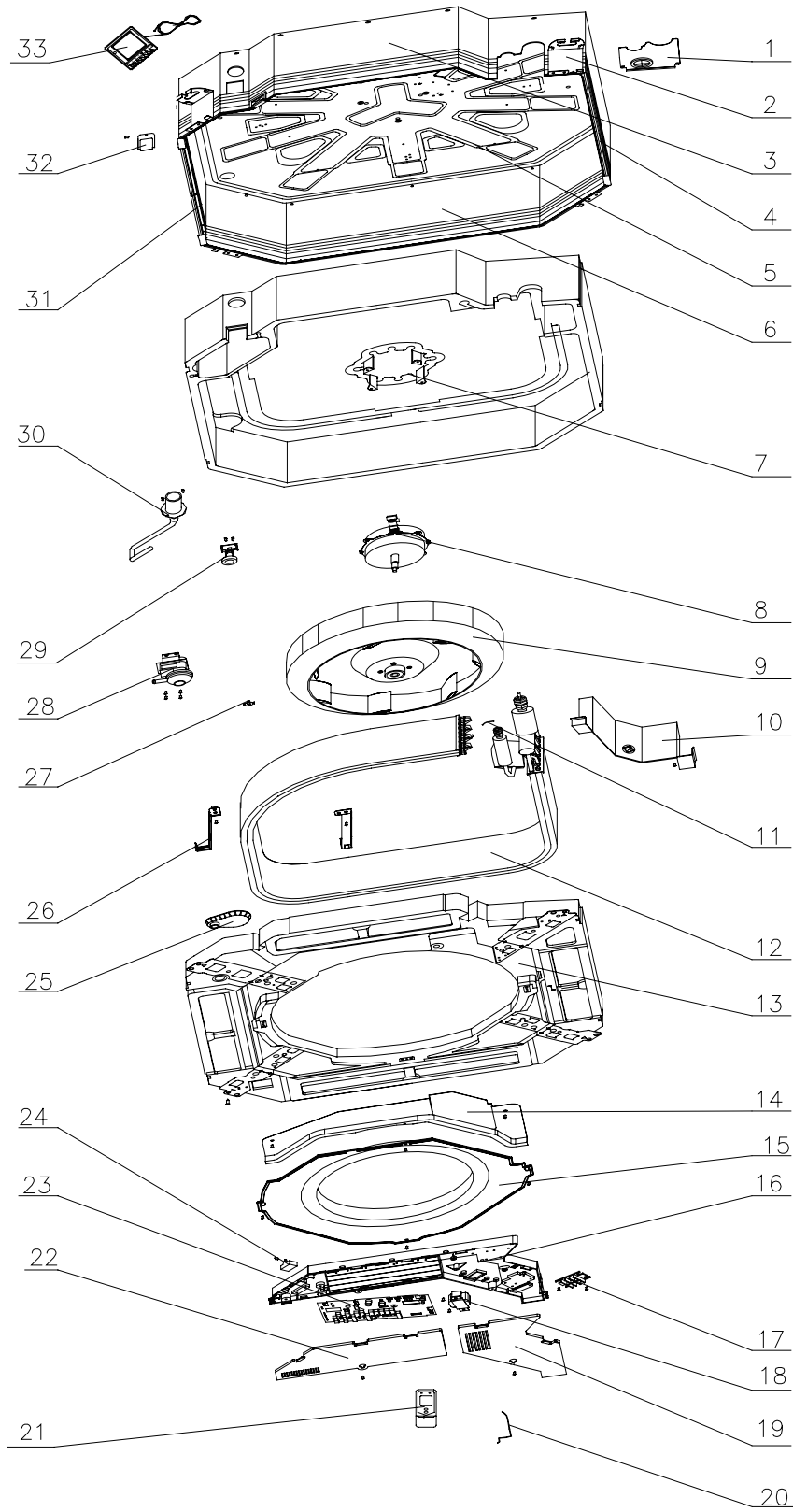

No	Description	GKH36K3CI	GKH42K3CI	Qty
		ET010N0210	ET010N0230	
	Name of Part	Part Code	Part Code	
1	Tube Exit Plate	'01382715	'01382715	1
2	Body Fixed Plate	1332701	1332701	1
3	Front Side Plate	01302713	01302713	1
4	Left Side Plate	'01302711	'01302711	1
5	Base Plate	'01222701	'01222701	1
6	Rear Side Plate	'01302709	'01302709	1
7	Motor Support	'01702701	'01702701	1
8	Motor FN60T	15012706	15012706	1
9	Centifugal Fan	'10310101	'10310101	1
10	Evaporator Linkage	'01072732	'01072732	1
11	Tube sensor	'390001921	'390001921	1
12	Evaporator Assy	1029423	1029422	1
13	Water Tray Assy	'20182701	'20182701	1
14	Electric Base Plate	'01412721	'01412721	1
15	Flow-guide Loop	'10372722	'10372722	1
16	Electric Box	'01399610	1399509	1
17	Terminal Board	'42010258	'42010258	1
18	Transformer	'43110233	'43110233	1
19	Electric Box Cover I	'20102702	'20102702	1
20	Room Sensor	'390001911	'390001911	1
21	Remote Controller	'305125063	'305125063	1
22	Electric Box Cover II	'20102703	'20102703	1
23	Main PCB	'30227111	'30227111	1
24	Capacitor	'33010012	'33010012	1
25	Drainage Plastic	'05232044	'05232044	1
26	Evap Support	'01072707	'01072707	2
27	Fan Fixer	'10312701	'10312701	1
28	Water Pump	'43130324	'43130324	1
29	Water Level Switch	'45010201	'45010201	1
30	Pump Drainpipe	'05230026	'05230026	1
31	Right Side Plate	'01302712	'01302712	1
32	Pump Cover Plate	'01252713	'01252713	1
33	Display Board	'30294219	'30294219	1

5.2.2 Floor Ceiling Type

Model:GTH09K3CI/GTH12K3CI/ GTH18K3CI/ GTH24K3CI exploded view and spare parts list.

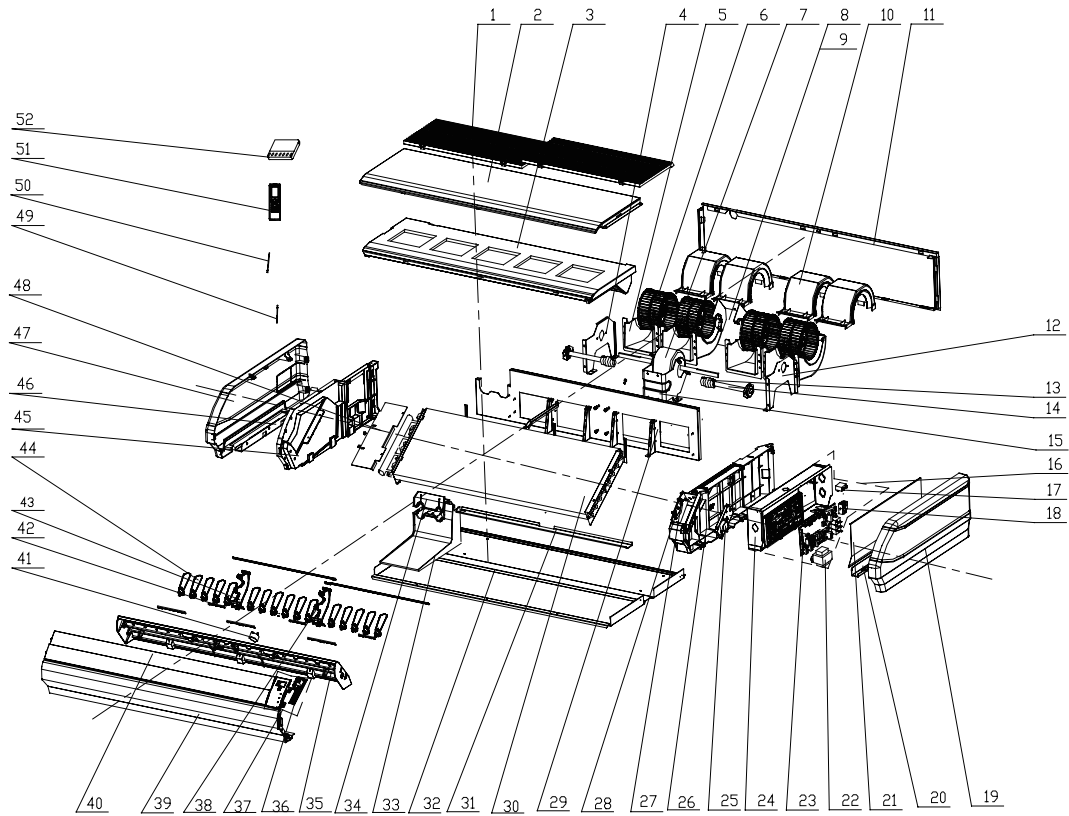

NO.	Description	GTH09K3CI	GTH12K3CI	GTH18K3CI	GTH24K3CI	Qty
		ED020N0171	ED020N0181	ED020N0191	ED020N0200	
	Name of Part	Part Code	Part Code	Part Code	Part Code	
1	Front Grill sub-assy	'01579403	'01579403	'01579403	'01579403	2
2	Top Cover Board Sub-assy	'01269409	'01269409	'01269409	'01269409	1
3	Water Tray Assy	'01289404	'01289404	'01289404	'01289404	1
4	Supporter	'01809417	'01809417	'01809417	'01809417	1
5	Rear volute casing	'26905206	'26905206	'26905206	'26905206	4
6	Centrifugal fan	'10425200	'10425200	'10425200	'10425200	4
7	Fan Motor	'1570940901	'1570940901	'1570940901	'1570940901	1
8	Clamping Band Assembly	'70815201	'70815201	'70815201	'70815201	1
9	Bar Clasp	'70818405	'70818405	'70818405	'70818405	1
10	Front volute casing	'26905205	'26905205	'26905205	'26905205	4
11	Rear connect plate	'01349416	'01349416	'01349416	'01349416	1
12	Supporter	'01809418	'01809418	'01809418	'01809418	1
13	Joint Slack	'73018731	'73018731	'73018731	'73018731	2
14	Rotary Axis Sub-Assy	2289405	2289405	2289405	2289405	2
15	Supporter	'01805288	'01805288	'01805288	'01805288	1
16	Electric Box Assy	'01399516	'01399516	'01399623	'01399501	1
17	Capacitor	'33010089	33010089	'33010025	'33010025	1
18	Terminal Board	'42010178	'42010178	'42010178	'42010178	1

19	Left Cover	'26909443	'26909443	'26909443	'26909443	1
20	Right Pensile Bracket	'01809401	'01809401	'01809401	'01809401	1
21	Electric Box Cover	'01429420	'01429420	'01429420	'01429420	1
22	Transformer	'4311023701	'4311023701	'4311023701	'4311023701	1
23	Main Board	'30224223	'30224223	'30224223	'30224223	1
24	Electric Box	'01429419	'01429419	'01429419	'01429419	1
25	Step Motor	'1521240201	'1521240201	'1521240201	'1521240201	1
26	Left Side Plate Sub-Assy	1319428	1319428	1319428	1319428	1
27	Rotating Shaft	'26909412	'26909412	'26909412	'26909412	1
28	Rotating Shaft	'26909413	'26909413	'26909413	'26909413	1
29	Mid-clapboard sub-assy	'01249416	'01249416	'01249416	'01249416	1
30	Evaporator Assy	01025372	01029473	'01029468	01029462	1
31	Air Deflector Sub-Assy	'02229418	'02229418	'02229418	'02229418	1
32	Rear side plate assy	'01319430	'01319430	'01319430	'01319430	1
33	Water Groove	26909450	26909450	26909450	26909450	1
34	Fixed Plate	'26909442	'26909442	'26909442	'26909442	1
35	Base Frame	'26909448	'26909448	'26909448	'26909448	1
36	Display Board	'30294219	'30294219	'30294219	'30294219	1
37	Display Board Sub-Assy	'02229416	'02229416	'02229416	'02229416	1
38	Rotating Shaft	'26909430	'26909430	'26909430	'26909430	4
39	Front connect plate	'01349414P	'01349414P	'01349414P	'01349414P	1
40	Guide Louver	'10619403	'10619403	'10619403	'10619403	2
41	Step Motor	'1521240206	'1521240206	'1521240206	'1521240206	1
42	Louver Clamp	'26112127	'26112127	'26112127	'26112127	3
43	Supporter	'26909449	'26909449	'26909449	'26909449	2
44	Air Louver	'10619404	'10619404	'10619404	'10619404	16
45	Right Side Plate Sub-Assy	'01319429	'01319429	'01319429	'01319429	1
46	Installation Supporting Frame	'01809402	'01809402	'01809402	'01809402	1
47	Right Cover	'26909444	'26909444	'26909444	'26909444	1
48	Connected Board (Evaporator)	1349421	1349421	1349421	1349421	1
49	Tube sensor	'3900020720	'3900020720	'3900020720	'3900020720	1
50	Room Sensor	'39000191	'39000191	'39000191	'39000191	1
51	Remote Controller	'305125063	'305125063	'305125063	'305125063	1
52	Display Board	'30294219	'30294219	'30294219	'30294219	1

Model:GTH30K3CI exploded view and spare parts list.

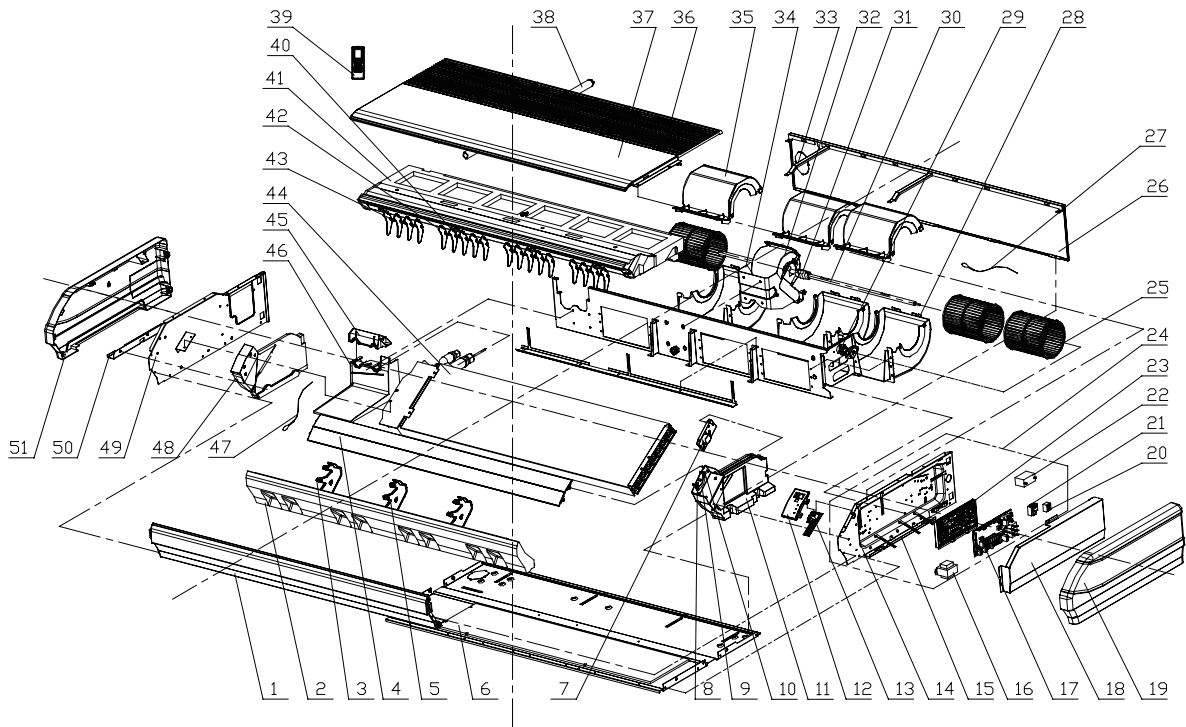

NO.	Description	GTH30K3CI	
		ED020N0210	Qty
		Name of Part	
1	Front panel	'01349408P	1
2	Front foam assy	'12509424	1
3	Rotating Shaft	'26909430	6
4	Guide Louver	'26909432	2
5	Bracket #3(Guide Louver)	'26909409	3
6	Rear side plate assy	'0131941901	1
7	Step Motor	'1521240206	1
8	Rotating Shaft	'26909413	1
9	Connecting Rod	'26909411	1
10	Rotating Shaft	'26909412	1
11	Left foam assy	'12509408	1
12	Display Board Sub-Assy	'02229416	1
13	Display Board	'30294219	1
14	Left Side Plate Sub-Assy	'01319406	1
15	Left Pensile Bracket	'01809401	1
16	Transformer	'4311023701	1
17	Main Board	'30224223	1
18	Electric Box Cover	'01429410P	1
19	Left Cover	'26909416	1
20	Terminal Board	'420101852	1
21	Terminal Board	'42010178	1
22	Capacitor	'33010013	1
23	Fixed Plate for mainboard	'26909407	1

24	Electric Box Assy	'01399476	1
25	Centrifugal fan	'1041410101	3
26	Rear connect plate	'01349410	1
27	Room Sensor	'39000191	1
28	Front volute casing	'26909419	3
29	O-Gasket of Bearing	76512404	1
30	Rotary Axis Sub-Assy	'73018052	1
31	Joint Slack	'73018731	1
32	Fan Motor	'15709408	1
33	Fixing plate	'02229408	2
34	Bracket for motor	01329413	1
35	Rear volute casing	'26909419	3
36	Front Grill sub-assy	'01579402	3
37	Top cover	'01269404P	1
38	Drainage Pipe Sub-assy	'05235434	1
39	Remote Controller	'305125063	1
40	Swing lever	'10582009	2
41	Water Tray Assy	'01289405	1
42	Air Louver	'26909418	18
43	Swing lever	'10582009	2
44	Evaporator Assy	01029457	1
45	Water Groove	'26909441	1
46	Fixed Plate	'26909442	1
47	Tube sensor	'3900020720	1
48	Right foam assy	'12509425	1
49	Right Side Plate Sub-Assy	'01319408	1
50	Right Pensile Bracket	'01809402	1
51	Right Cover	'26909422	1

Model:GTH36K3CI exploded view and spare parts list.

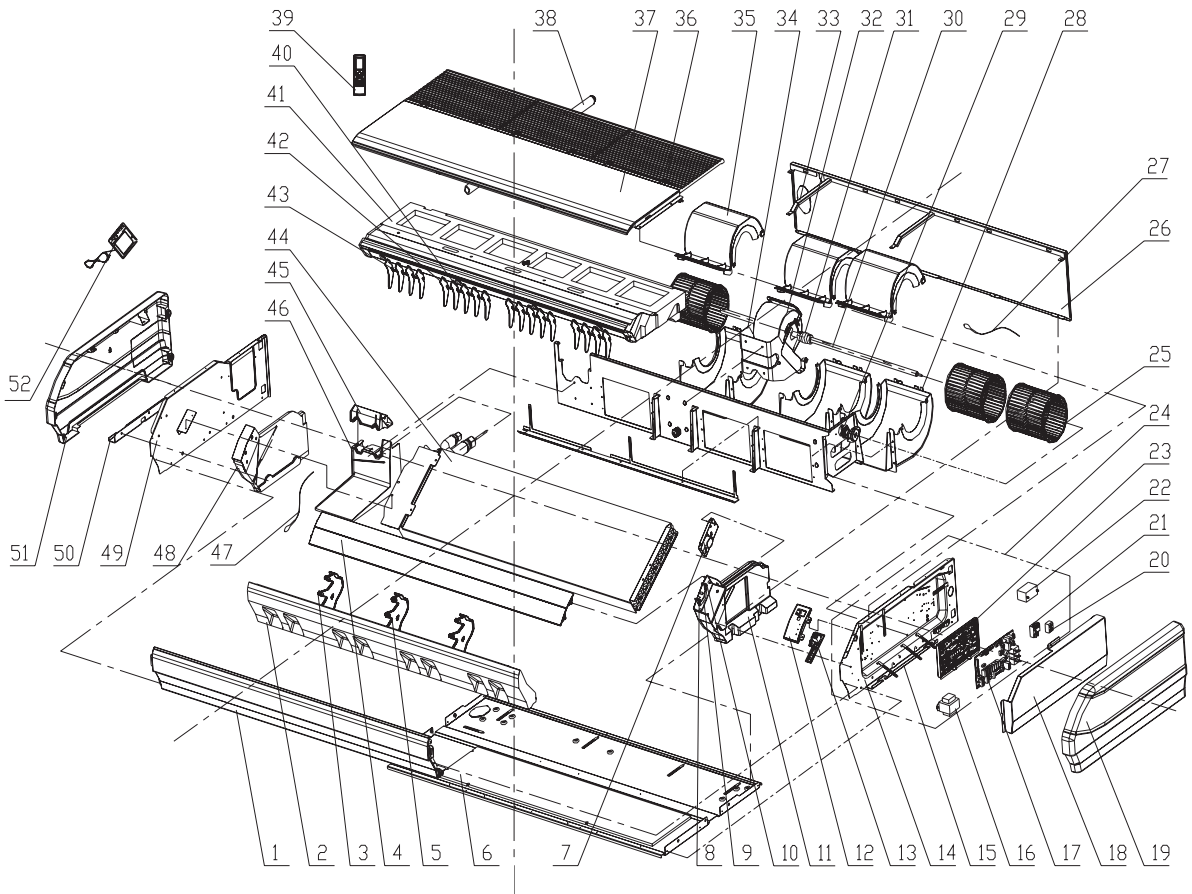

NO.	Description	GTH36K3CI	Qty
		ED020N0220	
	Name of Part	Part Code	
1	Front panel	01349408P	1
2	Front foam assy	'12509424	1
3	Rotating Shaft	'26909430	6
4	Guide Louver	'26909432	2
5	Bracket #3(Guide Louver)	'26909409	3
6	Rear side plate assy	'0131941901	1
7	Step Motor	'1521240206	1
8	Rotating Shaft	'26909413	1
9	Connecting Rod	'26909411	1
10	Rotating Shaft	'26909412	1
11	Left foam assy	'12509408	1
12	Display Board Sub-Assy	'02229416	1
13	Display Board	'30294224	1
14	Left Side Plate Sub-Assy	'01319406	1
15	Left Pensile Bracket	'01809401	1
16	Transformer	'4311023701	1
17	Main Board	'30224223	1
18	Electric Box Cover	'01429410P	1
19	Left Cover	'26909416	1
20	Terminal Board	'420101852	1
21	Terminal Board	'42010178	1
22	Capacitor	'33010014	1
23	Fixed Plate for mainboard	'26909407	1

24	Electric Box Assy	'01399459	1
25	Centrifugal fan	'1041410101	3
26	Rear connect plate	'01349410	1
27	Room Sensor	'39000191	1
28	Front volute casing	'26905208	3
29	O-Gasket of Bearing	76512404	1
30	Rotary Axis Sub-Assy	'73018052	1
31	Joint Slack	'73018731	1
32	Fan Motor	'15709407	1
33	Fixing plate	'02229408	2
34	Bracket for motor	'01329407	1
35	Rear volute casing	'26909419	3
36	Front Grill sub-assy	'01579402	3
37	Top cover	'01269404P	1
38	Drainage Pipe Sub-assy	'05235434	1
39	Remote Controller	'305125063	1
40	Swing lever	'10582008	2
41	Water Tray Assy	'01289405	1
42	Air Louver	'26909418	18
43	Swing lever	'10582009	2
44	Evaporator Assy	'01029455	1
45	Water Groove	'26909441	1
46	Fixed Plate	'26909442	1
47	Tube sensor	'3900020720	1
48	Right foam assy	'12509425	1
49	Right Side Plate Sub-Assy	'01319408	1
50	Right Pensile Bracket	'01809402	1
51	Right Cover	'26909422	1
52	Display Board	'305125063	1

Model:GTH42K3CI exploded view and spare parts list.

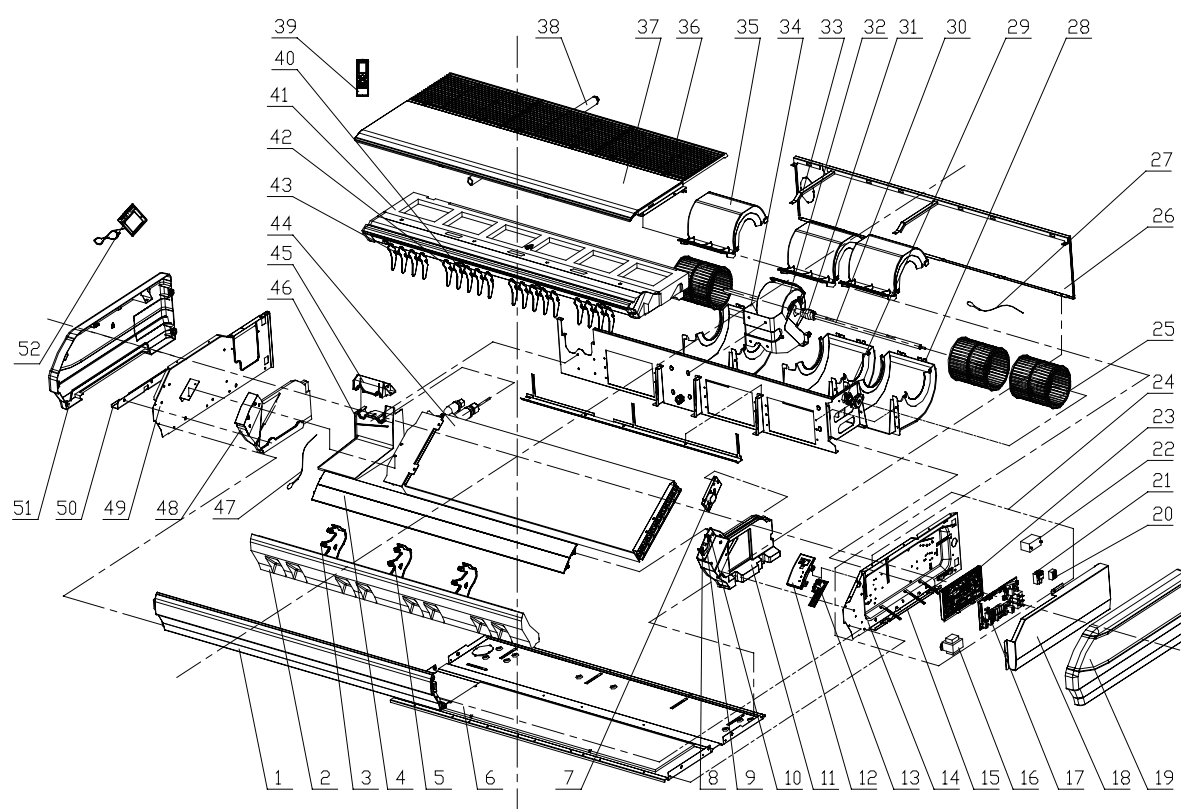

NO.	Description	GTH42K3CI	Qty
		ED020N0310	
	Name of Part	Part Code	
1	Front panel	'01349408P	1
2	Front foam assy	'12509424	1
3	Rotating Shaft	'26909430	6
4	Guide Louver	'26909432	2
5	Bracket #3(Guide Louver)	'26909409	3
6	Rear side plate assy	'0131941901	1
7	Step Motor	'1521240206	1
8	Rotating Shaft	'26909413	1
9	Connecting Rod	'26909411	1
10	Rotating Shaft	'26909412	1
11	Left foam assy	'12509408	1
12	Display Board Sub-Assy	'02229416	1
13	Display Board	'30294224	1
14	Left Side Plate Sub-Assy	'01319406	1
15	Left Pensile Bracket	'01809401	1
16	Transformer	'4311023701	1
17	Main Board	'30224223	1
18	Electric Box Cover	'01429410P	1
19	Left Cover	'26909416	1
20	Terminal Board	'420101852	1
21	Terminal Board	'42010178	1
22	Capacitor	'33010014	1
23	Fixed Plate for mainboard	'26909407	1
24	Electric Box Assy	'01399459	1
25	Centrifugal fan	'1041410101	3
26	Rear connect plate	'01349410	1
27	Room Sensor	'39000191	1
28	Front volute casing	'26905208	3
29	O-Gasket of Bearing	76512404	1
30	Rotary Axis Sub-Assy	'73018052	1
31	Joint Slack	'73018731	1
32	Fan Motor	'15709407	1
33	Fixing plate	'02229408	2
34	Bracket for motor	'01329407	1
35	Rear volute casing	'26909419	3
36	Front Grill sub-assy	'01579402	3
37	Top cover	'01269404P	1
38	Drainage Pipe Sub-assy	'05235434	1
39	Remote Controller	'305125063	1
40	Swing lever	'10582008	2
41	Water Tray Assy	'01289405	1
42	Air Louver	'26909418	18
43	Swing lever	'10582009	2
44	Evaporator Assy	'01029454	1
45	Water Groove	'26909441	1
46	Fixed Plate	'26909442	1
47	Tube sensor	'3900020720G	1
48	Right foam assy	'12509425	1
49	Right Side Plate Sub-Assy	'01319408	1
50	Right Pensile Bracket	'01809402	1
51	Right Cover	'26909422	1
52	Display Board	'30294219	1

Model:GTH48K3CI/ GTH60K3CI exploded view and spare parts list.

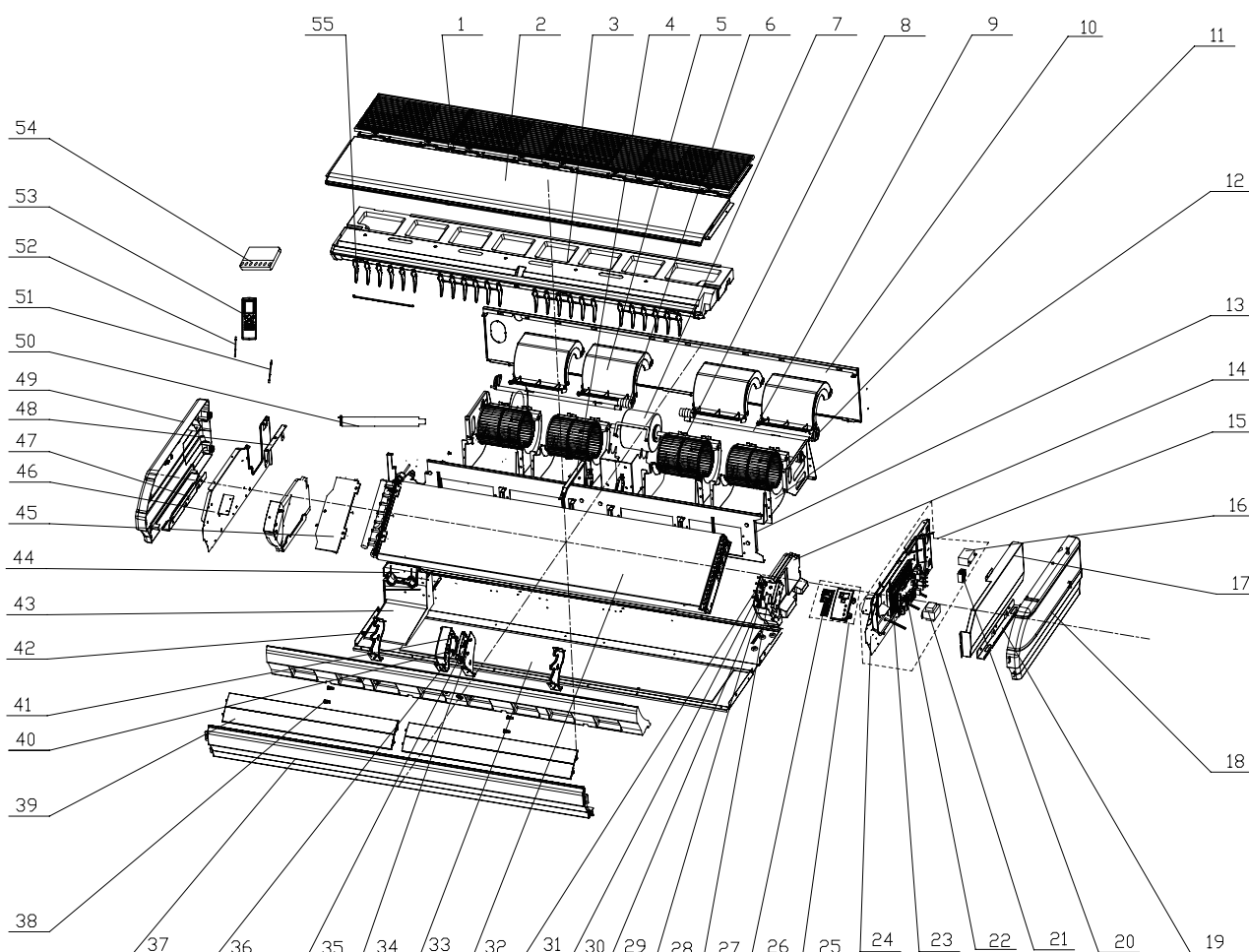

NO.	Description	GTH48K3CI	GTH60K3CI	Qty
		ED020N0230	ED020N0440	
	Name of Part	Part Code	Part Code	
1	Front Grill sub-assy	'01579401	'01579401	4
2	Top Cover Board Sub-assy	'01269403	'01269403	1
3	Water Tray Assy	'01289401	'01289401	1
4	Spacing Board	'02229408	'02229408	2
5	Rear volute casing	'26909419	'26909419	4
6	Joint Slack	'73018731	'73018731	2
7	Fan Motor	'15709405	'15709405	1
8	Centrifugal fan	'1041410101	'1041410101	4
9	Rotary Axis Sub-Assy	'73018052	'73018052	2
10	Rear Connection Board	'01349411	'01349411	1
11	Support Of Motor Bearing	'01792408	'01792408	2
12	Front volute casing	'26905208	'26905208	4
13	Mid Clapboard	'0124940202	'0124940202	1
14	Left Foam Assembly	'12509408	'12509408	1
15	Electric Box Assy	'01399512	'01399513	1
16	Capacitor	'33010014	'33010014	1
17	Electric Box Cover	'01429410P	'01429410P	1
18	Left Cover Plate	'26909422	'26909422	1
19	Installation Supporting Frame	01809401	01809401	1

20	Terminal Board	'42010178	'42010178	1
21	Transformer	'4311023701	'4311023701	1
22	Main Board	'30224223	'30224223	1
23	PCB Base	'26909407	'26909407	1
24	Left Side Plate Sub-Assy	'01319406	'01319406	1
25	Display Board Sub-Assy	'02229416	'02229416	1
26	Display Board	'30294224	'30294224	1
27	Step Motor	'1521240206	'1521240206	1
28	Axile Bush	'10542704	'10542704	2
29	Connecting Rod	'26909411	'26909411	1
30	Rotating Shaft	'26909413	'26909413	1
31	Rotating Shaft	'26909412	'26909412	1
32	Evaporator Assy	'01029466	'01029471	1
33	Rear side plate assy	'01319422	'01319422	1
34	Axile Bush	'10542704	'10542704	2
35	Step Motor	'1521240201	'1521240201	1
36	Connecting Rod	'26909411	'26909411	1
37	Front connect plate	'01349404P	'01349404P	1
38	Rotating Shaft	'26909430	'26909430	4
39	Guide Louver	'26909408	'26909408	4
40	Rotating Shaft	'26909413	'26909413	1
41	Rotating Shaft	'26909412	'26909412	1
42	Supporter	'26909409	'26909409	2
43	Water Groove	'26909441	'26909441	1
44	Fixed Plate	'26909442	'26909442	1
45	Connected Board (Evaporator)	'01349412	'01349412	1
46	Right Side Plate Sub-Assy	'01319408	'01319408	1
47	Installation Supporting Frame	'01809402	'01809402	1
48	Connection Board	'02229406	'02229406	1
49	Right Cover Plate	'26909422	'26909422	1
50	Drainage Pipe Sub-assy	'05235434	'05235434	1
51	Room Sensor	'39000191	'39000191	1
52	Tube sensor	'3900020720G	'3900020720G	1
53	Remote Controller	'305125063	'305125063	1
54	Display Board	'30294219	'30294219	1
55	Air Louver	'26909418	'26909418	24



JF00300705

GREE ELECTRIC APPLIANCES, INC. OF ZHUHAI

Add: West Jinji Rd, Qianshan, Zhuhai, Guangdong, China, 519070

Tel: (+86-756) 8522218 Fax: (+86-756) 8669426

E-mail: gree@gree.com.cn www.gree.com

For continuous improvement in the products, Gree reserves the right to modify the product specification and appearance in this manual without notice and without incurring any obligations.